



SAR TEST REPORT

HCT CO., LTD

FCC Class II Permissive Change

EUT Type:	Dual-Band CDMA Phone (CDMA/PCS CDMA)		
FCC ID:	PP4EZ2		
Model:	EZ2	Trade Name	PANTECH&CURITEL
Date of Issue:	Jan.16, 2008		
Test report No.:	HCT-SAR08-0110		
Test Laboratory:	HCT CO., LTD. SAN 136-1, AMI-RI, BUBAL-EUP, ICHEON-SI, KYOUNGKI-DO, 467-701, KOREA TEL: +82 31 639 8565 FAX: +82 31 639 8525		
Applicant :	PANTECH&CURITEL COMMUNICATIONS, INC. 110-1, ONGJEONG-RI, TONGJIN-EUP, GIMPO-SI, GYOUNGGI-DO, 415-865, KOREA Tel: +82-31-999-8801 Fax: +82-31-984-9771 E-Mail: leekiyeoul@pantech.com		
Testing has been carried out in accordance with:	47CFR §2.1093 FCC OET Bulletin 65(Edition 97-01), Supplement C (Edition 01-01) ANSI/ IEEE C95.1 – 2005 IEEE 1528-2003		
Test result:	The tested device complies with the requirements in respect of all parameters subject to the test. The test results and statements relate only to the items tested. The test report shall not be reproduced except in full, without written approval of the laboratory.		
Signature	 <hr/> Report prepared by : Sun-Hee Kim Test Engineer of SAR Part	 <hr/> Approved by : Nam-Wook Kang Manager of SAR Part	

Table of Contents

<u>1. INTRODUCTION</u>	3
<u>2. DESCRIPTION OF DEVICE</u>	4
<u>3. DESCRIPTION OF TEST EQUIPMENT</u>	5
<u>3.1 SAR MEASUREMENT SETUP</u>	5
<u>3.2 DASY E-FIELD PROBE SYSTEM</u>	6
<u>3.3 PROBE CALIBRATION PROCESS</u>	7
<u>3.4 SAM Phantom</u>	9
<u>3.5 Device Holder for Transmitters</u>	9
<u>3.6 Brain & Muscle Simulating Mixture Characterization</u>	10
<u>3.7 SAR TEST EQUIPMENT</u>	11
<u>4. SAR MEASUREMENT PROCEDURE</u>	12
<u>5. DESCRIPTION OF TEST POSITION</u>	13
<u>5.1 HEAD POSITION</u>	13
<u>5.2 Body Holster/Belt Clip Configurations</u>	14
<u>6. MEASUREMENT UNCERTAINTY</u>	15
<u>7. ANSI/ IEEE C95.1 - 2005 RF EXPOSURE LIMITS</u>	16
<u>8. SYSTEM VERIFICATION</u>	17
<u>8.1 Tissue Verification</u>	17
<u>8.2 System Validation</u>	17
<u>9. 3G MEASUREMENT PROCEDURES</u>	18
<u>9.1 Procedures Used To Establish Test Signal</u>	18
<u>9.2 SAR Measurement Conditions for CDMA2000 1x</u>	18
<u>10. SAR TEST DATA SUMMARY</u>	20
<u>10.1 Measurement Results (CDMA835 Head SAR Touch)</u>	20
<u>10.2 Measurement Results (CDMA835 Head SAR Tilt)</u>	21
<u>10.3 Measurement Results (PCS1900 Head SAR Touch)</u>	22
<u>10.4 Measurement Results (PCS1900 Head SAR Tilt)</u>	23
<u>10.5 Measurement Results (CDMA835 Body SAR)</u>	24
<u>10.6 Measurement Results (PCS1900 Body SAR)</u>	25
<u>11. CONCLUSION</u>	26
<u>12. REFERENCES</u>	27
Attachment 1. – SAR Test Plots	28
Attachment 2. – Dipole Validation Plots	57
Attachment 3. – Probe Calibration Data	64
Attachment 4. – Dipole Calibration Data	74

1. INTRODUCTION

The FCC has adopted the guidelines for evaluating the environmental effects of radio frequency radiation in ET Docket 93-62 on Aug. 6, 1996 to protect the public and workers from the potential hazards of RF emissions due to FCC-regulated portable devices.

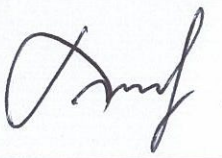
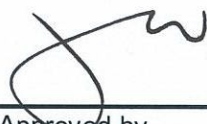
The safety limits used for the environmental evaluation measurements are based on the criteria published by the American National Standards Institute (ANSI) for localized specific absorption rate (SAR) in IEEE/ANSI C95.1-2005 Standard for Safety Levels with Respect to Human Exposure to Radio Frequency Electromagnetic Fields, 3 kHz to 300 GHz. 1992 by the Institute of Electrical and Electronics Engineers, Inc., New York, New York 10017. The measurement procedure described in IEEE/ANSI C95.3-1992 Recommended Practice for the Measurement of Potentially Hazardous Electromagnetic Fields - RF and Microwave is used for guidance in measuring SAR due to the RF radiation exposure from the Equipment Under Test (EUT). These criteria for SAR evaluation are similar to those recommended by the National Council on Radiation Protection and Measurements (NCRP) in Biological Effects and Exposure Criteria for Radio frequency Electromagnetic Fields," NCRP Report No. 86 NCRP, 1986, Bethesda, MD 20814. SAR is a measure of the rate of energy absorption due to exposure to an RF transmitting source. SAR values have been related to threshold levels for potential biological hazards.

SAR Definition

Specific Absorption Rate (SAR) is defined as the time derivative (rate) of the incremental energy (dU) absorbed by (dissipated in) an incremental mass (dm) contained in a volume element (dV) of a given density (r). It is also defined as the rate of RF energy absorption per unit mass at a point in an absorbing body.

$$SAR = \frac{d}{dt} \left(\frac{dU}{dm} \right) = \frac{d}{dt} \left(\frac{dU}{\rho dV} \right)$$

Figure 2. SAR Mathematical Equation

SAR is expressed in units of Watts per Kilogram (W/kg).

$$SAR = \sigma E^2 / \rho$$

where:

- σ = conductivity of the tissue-simulant material (S/m)
- ρ = mass density of the tissue-simulant material (kg/m³)
- E = Total RMS electric field strength (V/m)

NOTE: The primary factors that control rate of energy absorption were found to be the wavelength of the incident field in relations to the dimensions and geometry of the irradiated organism, the orientation of the organism in relation to the polarity of field vectors, the presence of reflecting surfaces, and whether conductive contact is made by the organism with a ground plane.

2. DESCRIPTION OF DEVICE

Environmental evaluation measurements of specific absorption rate (SAR) distributions in emulated human head and body tissues exposed to radio frequency (RF) radiation from wireless portable devices for compliance with the rules and regulations of the U.S. Federal Communications Commission (FCC).

EUT Type	Dual-Band CDMA Phone (CDMA/PCS CDMA)
FCC ID	PP4EZ2
Model(s)	EZ2
Trade Name	PANTECH&CURITEL
Serial Number(s)	#1
Application Type	Permissive Change Class II
Change of Contents	PAM/PCB have been changed
Modulation(s)	CDMA835/PCS1900
Tx Frequency	824.70 - 848.31 MHz (CDMA) 1 851.25 – 1 908.75 MHz (PCS CDMA)
Rx Frequency	869.70 - 893.31 MHz (CDMA) 1 931.25 – 1 988.75 MHz (PCS CDMA)
FCC Classification	Licensed Portable Transmitter Held to Ear (PCE)
Production Unit or Identical Prototype	Prototype
Max SAR	1.2 W/kg CDMA835 Head SAR / 0.447 W/kg CDMA835 Body SAR 0.972 W/kg PCS1900 Head SAR / 0.36 W/kg PCS1900 Body SAR
Date(s) of Tests	Jan. 14, 2008 ~ Jan. 15, 2008
Antenna Type	Intenna

3. DESCRIPTION OF TEST EQUIPMENT

3.1 SAR MEASUREMENT SETUP

These measurements are performed using the DASY4 automated dosimetric assessment system. It is made by Schmid & Partner Engineering AG (SPEAG) in Zurich, Switzerland. It consists of high precision robotics system (Staubli), robot controller, Pentium III computer, near-field probe, probe alignment sensor, and the generic twin phantom containing the brain equivalent material. The robot is a six-axis industrial robot performing precise movements to position the probe to the location (points) of maximum electromagnetic field (EMF) (see Figure 3.1).

A cell controller system contains the power supply, robot controller, teach pendant (Joystick), and remote control, is used to drive the robot motors. The PC consists of the HP Pentium IV 3.0GHz computer with Windows XP system and SAR Measurement Software DASY4, A/D interface card, monitor, mouse, and keyboard. The Staubli Robot is connected to the cell controller to allow software manipulation of the robot. A data acquisition electronic (DAE) circuit performs the signal amplification, signal multiplexing, AD-conversion, offset measurements, mechanical surface detection, collision detection, etc. is connected to the Electro-optical coupler (EOC). The EOC performs the conversion from the optical into digital electric signal of the DAE and transfers data to the PC plug-in card.

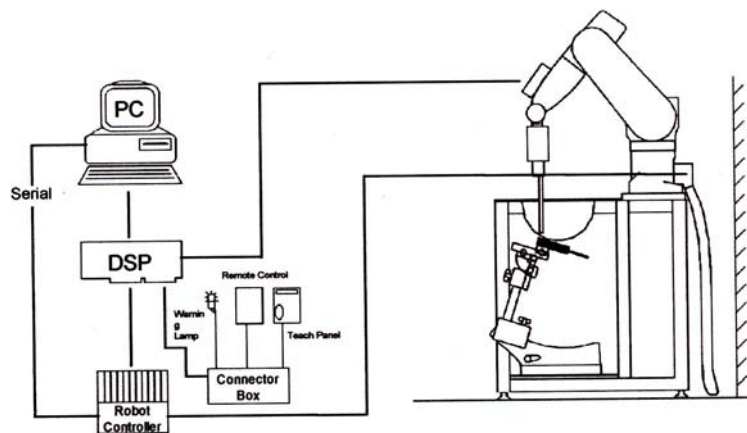

Figure 3.1 HCT SAR Lab. Test Measurement Set-up

The DAE4 consists of a highly sensitive electrometer-grade preamplifier with auto-zeroing, a channel and gain-switching multiplexer, a fast 16 bit AD-converter and a command decoder and control logic unit. Transmission to the PC-card is accomplished through an optical downlink for data and status information and an optical uplink for commands and clock lines. The mechanical probe mounting device includes two different sensor systems for frontal and sidewise probe contacts. They are also used for mechanical surface detection and probe collision detection. The robot uses its own controller with a built in VME-bus computer. The system is described in detail in.

3.2 DASY E-FIELD PROBE SYSTEM

3.2.1 ET3DV6 Probe Specification

Construction	Symmetrical design with triangular core Built-in optical fiber for surface detection System Built-in shielding against static charges
Calibration	In air from 10 MHz to 2.5 GHz In brain and muscle simulating tissue at Frequencies of 450 MHz, 900 MHz and 1.8 GHz (accuracy: 8 %)
Frequency	10 MHz to > 6 GHz; Linearity: ± 0.2 dB (30 MHz to 3 GHz)
Directivity	± 0.2 dB in brain tissue (rotation around probe axis) ± 0.4 dB in brain tissue (rotation normal probe axis)
Dynamic	5 μ W/g to > 100 mW/g;
Range Linearity:	± 0.2 dB
Surface Detection	± 0.2 mm repeatability in air and clear liquids over diffuse reflecting surfaces.
Dimensions	Overall length: 330 mm Tip length: 16 mm Body diameter: 12 mm Tip diameter: 6.8 mm Distance from probe tip to dipole centers: 2.7 mm
Application	General dissymmetry up to 3 GHz Compliance tests of mobile phones Fast automatic scanning in arbitrary phantoms



Figure 3.2 Photograph of the probe and the Phantom



Figure 3.3 ET3DV6 E-field Probe

The SAR measurements were conducted with the dosimetric probe ET3DV6, designed in the classical triangular configuration and optimized for dosimetric evaluation. The probe is constructed using the thick film technique; with printed resistive lines on ceramic substrates. The probe is equipped with an optical multifiber line ending at the front of the probe tip. It is connected to the EOC box on the robot arm and provides an automatic detection of the phantom surface. Half of the fibers are connected to a pulsed infrared transmitter, the other half to a synchronized receiver. As the probe approaches the surface, the reflection from the surface produces a coupling from the transmitting to the receiving fibers. This reflection increases first during the approach, reaches a maximum and then decreases. If the probe is flatly touching the surface, the coupling is zero. The distance of the coupling maximum to the surface is independent of the surface reflectivity and largely independent of the surface to probe angle. The DASY4 software reads the reflection during a software approach and looks for the maximum using a 2nd order fitting. The approach is stopped at reaching the maximum.

3.3 PROBE CALIBRATION PROCESS

3.3.1 E-Probe Calibration

Each probe is calibrated according to a dosimetric assessment procedure with an accuracy better than $\pm 10\%$. The spherical isotropy was evaluated with the proper procedure and found to be better than ± 0.25 dB. The sensitivity parameters (NormX, NormY, NormZ), the diode compression parameter (DCP) and the conversion factor (ConvF) of the probe is tested.

The free space E-field from amplified probe outputs is determined in a test chamber. This is performed in a TEM cell for frequencies below 1 GHz, and in a waveguide above 1 GHz for free space. For the free space calibration, the probe is placed in the volumetric center of the cavity and at the proper orientation with the field. The probe is then rotated 360 degrees.

E-field temperature correlation calibration is performed in a flat phantom filled with the appropriate simulated brain tissue. The measured free space E-field in the medium correlates to temperature rise in a dielectric medium. For temperature correlation calibration a RF transparent thermistor-based temperature probe is used in conjunction with the E-field probe.

$$SAR = C \frac{\Delta T}{\Delta t}$$

where:

- Δt = exposure time (30 seconds),
- C = heat capacity of tissue (brain or muscle),
- ΔT = temperature increase due to RF exposure.

SAR is proportional to $\Delta T / \Delta t$, the initial rate of tissue heating, before thermal diffusion takes place. Now it's possible to quantify the electric field in the simulated tissue by equating the thermally derived SAR to the E- field;

$$SAR = \frac{|E|^2 \cdot \sigma}{\rho}$$

where:

- σ = simulated tissue conductivity,
- ρ = Tissue density (1.25 g/cm³ for brain tissue)

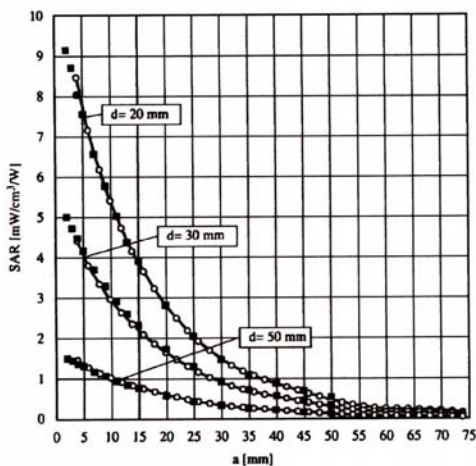

Figure 3.4 E-Field and Temperature measurements at 900 MHz

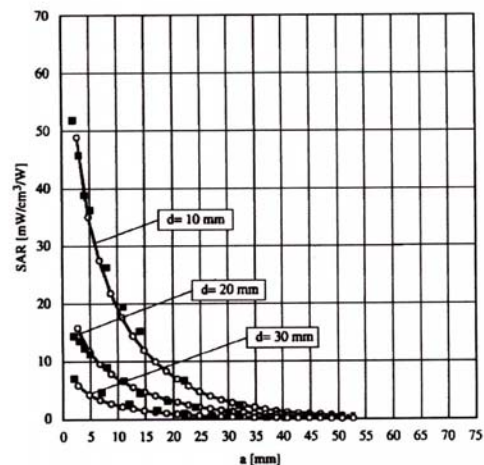

Figure 3.5 E-Field and temperature measurements at 1.8 GHz

3.3.2 Data Extrapolation

The DASY4 software automatically executes the following procedures to calculate the field units from the :microvolt readings at the probe connector. The first step of the evaluation is a linearization of the filtered input signal to account for the compression characteristics of the detector diode. The compensation depends on the input signal, the diode type and the DC-transmission factor from the diode to the evaluation electronics. If the exciting field is pulsed, the crest factor of the signal must be known to correctly compensate for peak power. The formula for each channel can be given like below;

$$V_i = U_i + U_i^2 \cdot \frac{cf}{dcp_i}$$

with V_i = compensated signal of channel i (i=x,y,z)
 U_i = input signal of channel i (i=x,y,z)
 cf = crest factor of exciting field (DASY parameter)
 dcp_i = diode compression point (DASY parameter)

From the compensated input signals the primary field data for each channel can be evaluated:

E-field probes:

$$E_i = \sqrt{\frac{V_i}{Norm_i \cdot ConvF}}$$

with V_i = compensated signal of channel i (i = x,y,z)
 $Norm_i$ = sensor sensitivity of channel i (i = x,y,z)
 $\mu V/(V/m)^2$ for E-field probes
 $ConvF$ = sensitivity of enhancement in solution
 E_i = electric field strength of channel i in V/m

The RSS value of the field components gives the total field strength (Hermetian magnitude):

$$E_{tot} = \sqrt{E_x^2 + E_y^2 + E_z^2}$$

The primary field data are used to calculate the derived field units.

$$SAR = E_{tot}^2 \cdot \frac{\sigma}{\rho \cdot 1000}$$

with SAR = local specific absorption rate in W/g
 E_{tot} = total field strength in V/m
 σ = conductivity in [mho/m] or [Siemens/m]
 ρ = equivalent tissue density in g/cm³

The power flow density is calculated assuming the excitation field to be a free space field.

$$P_{pwe} = \frac{E_{tot}^2}{3770}$$

with P_{pwe} = equivalent power density of a plane wave in W/cm²
 E_{tot} = total electric field strength in V/m

3.4 SAM Phantom

The SAM Phantom is constructed of a fiberglass shell integrated in a wooden table. The shape of the shell is based on data from an anatomical study designed to determine the maximum exposure in at least 90 % of all users. It enables the dosimetric evaluation of left and right hand phone usage as well as body mounted usage at the flat phantom region. A cover prevents the evaporation of the liquid. Reference markings on the Phantom allow the complete setup of all predefined phantom positions and measurement grids by manually teaching three points in the robot.

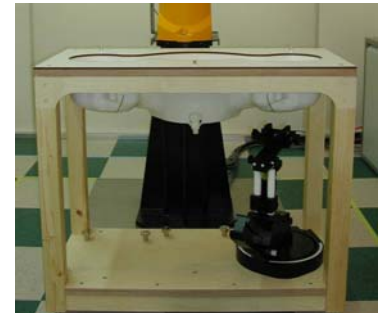

Figure 3.6 SAM Phantom

Shell Thickness	2.0 mm
Filling Volume	about 30 L
Dimensions	810 mm x 1 000 mm x 500 mm (H x L x W)

3.5 Device Holder for Transmitters

In combination with the SAM Phantom V 4.0, the Mounting Device (POM) enables the rotation of the mounted transmitter in spherical coordinates whereby the rotation points is the ear opening. The devices can be easily, accurately, and repeatably positioned according to the FCC and CENELEC specifications. The device holder can be locked at different phantom locations (left head, right head, flat phantom).

Note: A simulating human hand is not used due to the complex anatomical and geometrical structure of the hand that may produce an infinite number of configurations. To produce the Worst-case condition (the hand absorbs antenna output power), the hand is omitted during the tests.



Figure 3.7 Device Holder

3.6 Brain & Muscle Simulating Mixture Characterization

The brain and muscle mixtures consist of a viscous gel using hydrox-ethyl cellulose (HEC) gelling agent and saline solution (see Table 3.1). Preservation with a bactericide is added and visual inspection is made to make sure air bubbles are not trapped during the mixing process. The mixture is calibrated to obtain proper dielectric constant (permittivity) and conductivity of the desired tissue. The mixture characterizations used for the brain and muscle tissue simulating liquids are according to the data by C. Gabriel and G. Hartsgrove.

Ingredients (% by weight)	Frequency (MHz)									
	450		835		915		1 900		2 450	
Tissue Type	Head	Body	Head	Body	Head	Body	Head	Body	Head	Body
Water	38.56	51.16	41.45	52.4	41.05	56.0	54.9	40.4	62.7	73.2
Salt (NaCl)	3.95	1.49	1.45	1.4	1.35	0.76	0.18	0.5	0.5	0.04
Sugar	56.32	46.78	56.0	45.0	56.5	41.76	0.0	58.0	0.0	0.0
HEC	0.98	0.52	1.0	1.0	1.0	1.21	0.0	1.0	0.0	0.0
Bactericide	0.19	0.05	0.1	0.1	0.1	0.27	0.0	0.1	0.0	0.0
Triton X-100	0.0	0.0	0.0	0.0	0.0	0.0	0.0	0.0	36.8	0.0
DGBE	0.0	0.0	0.0	0.0	0.0	0.0	44.92	0.0	0.0	26.7

Salt:	99 % Pure Sodium Chloride	Sugar:	98 % Pure Sucrose
Water:	De-ionized, 16M resistivity	HEC:	Hydroxyethyl Cellulose
DGBE:	99 % Di(ethylene glycol) butyl ether,[2-(2-butoxyethoxy) ethanol]		
Triton X-100(ultra pure):	Polyethylene glycol mono[4-(1,1,3,3-tetramethylbutyl)phenyl] ether		

Table 3.1 Composition of the Tissue Equivalent Matter

3.7 SAR TEST EQUIPMENT

Manufacturer	Type / Model	S/N	Calib. Date	Calib.Interval	Calib.Due
SPEAG	SAM Phantom	-	N/A	N/A	N/A
Staubli	Robot RX90L	F01/5K09A1/A/01	N/A	N/A	N/A
Staubli	Robot ControllerCS7MB	F99/5A82A1/C/01	N/A	N/A	N/A
HP	Pavilion t000_puffer	KRJ51201TV	N/A	N/A	N/A
SPEAG	Light Alignment Sensor	265	N/A	N/A	N/A
Staubli	Teach Pendant (Joystick)	D221340.01	N/A	N/A	N/A
SPEAG	DAE4V1	447	Sep.13, 2007	Annual	Sep.13, 2008
SPEAG	DAE3V1	466	Jan.25, 2007	Annual	Jan.25, 2008
SPEAG	E-Field Probe ES3DV3	3085	Nov.19, 2007	Annual	Nov.19, 2008
SPEAG	E-Field Probe ET3DV6	1607	Feb.21, 2007	Annual	Feb.21, 2008
SPEAG	E-Field Probe ET3DV6	1609	Aug.30, 2007	Annual	Aug.30, 2008
SPEAG	Validation Dipole D450V2	1007	Mar.15, 2007	Annual	Mar.15, 2008
SPEAG	Validation Dipole D835V2	481	May 24, 2007	Annual	May 24, 2008
SPEAG	Validation Dipole D900V2	121	Feb.19, 2007	Annual	Feb.19, 2008
SPEAG	Validation Dipole D1800V2	2d066	May 23, 2007	Annual	May 23, 2008
SPEAG	Validation Dipole D1900V2	5d032	Feb.20, 2007	Annual	Feb.20, 2008
Agilent	Power Meter(F) E4419B	MY40330223	Nov.08, 2007	Annual	Nov.08, 2008
Agilent	Power Sensor(G) 8481	MY41090870	Nov.21, 2007	Annual	Nov.21, 2008
HP	Dielectric Probe Kit 85070C	00721521	N/A	N/A	N/A
HP	Dual Directional Coupler	16072	Nov.09, 2007	Annual	Nov.09, 2008
R&S	Base Station CMU200	838207/050	Nov.14, 2007	Annual	Nov.14, 2008
Tescom	Bluetooth TC-3000	3000A490112	Jan.22, 2007	Annual	Jan.22, 2008
Agilent	Base Station E5515C	GB44400269	Feb.11, 2007	Annual	Feb.11, 2008
HP	Signal Generator E4438C	MY45092381	Feb.07, 2007	Annual	Feb.07, 2008
HP	Network Analyzer 8753ES	JP39240221	Apr.11, 2007	Annual	Apr.11, 2008
EM POWER	Power Amp BBS3Q7ELU	1013-D/C-0127	Apr.17, 2007	Annual	Apr.17, 2008

NOTE:

The E-field probe was calibrated by SPEAG, by the waveguide technique procedure. Dipole Validation measurement is performed by HCT Lab. before each test. The brain simulating material is calibrated by HCT using the dielectric probe system and network analyzer to determine the conductivity and permittivity (dielectric constant) of the brain-equivalent material.

4. SAR MEASUREMENT PROCEDURE

The evaluation was performed with the following procedure:

1. The SAR value at a fixed location above the ear point was measured and was used as a reference value for assessing the power drop.
2. The SAR distribution at the exposed side of the head was measured at a distance of 3.9 mm from the inner surface of the shell. The area covered the entire dimension of the head and the horizontal grid spacing was 20 mm x 20 mm. Based on this data, the area of the maximum absorption was determined by spline interpolation.
3. Around this point, a volume of 32 mm x 32 mm x 34 mm was assessed by measuring 5 x 5 x 7 points. On this basis of this data set, the spatial peak SAR value was evaluated with the following procedure:
 - a. The data at the surface were extrapolated, since the center of the dipoles is 2.7 mm away from the tip of the probe and the distance between the surface and the lowest measuring point is 1.2 mm. The extrapolation was based on a least square algorithm. A polynomial of the fourth order was calculated through the points in z-axes. This polynomial was then used to evaluate the points between the surface and the probe tip.
 - b. The maximum interpolated value was searched with a straight-forward algorithm. Around this maximum the SAR values averaged over the spatial volumes (1 g or 10 g) were computed using the 3D-Spline interpolation algorithm. The 3D-spline is composed of three one-dimensional splines with the "Not a knot" condition (in x,y, and z directions. The volume was integrated with the trapezoidal algorithm. One thousand points (10 x 10 x 10) were interpolated to calculate the average.
 - c. All neighboring volumes were evaluated until no neighboring volume with a higher average value was found.
4. The SAR value, at the same location as procedure #1, was re-measured. If the value changed by more than 5 %, the evaluation is repeated.

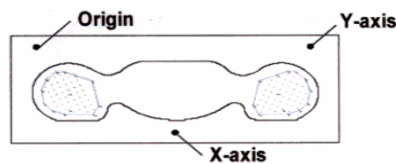

Figure 4.1 SAR Measurement Point in Area Scan

5. DESCRIPTION OF TEST POSITION

5.1 HEAD POSITION

The device was placed in a normal operating position with the Point A on the device, as illustrated in following drawing, aligned with the location of the RE(ERP) on the phantom. With the ear-piece pressed against the head, the vertical center line of the body of the handset was aligned with an imaginary plane consisting of the RE, LE and M. While maintaining these alignments, the body of the handset was gradually moved towards the cheek until any point on the mouth-piece or keypad contacted the cheek. This is a cheek/touch position. For ear/tilt position, while maintain the device aligned with the BM and FN lines, the device was pivot against ERP back for 15° or until the device antenna touch the phantom. Please refer to IEEE 1528-2003 illustration below.

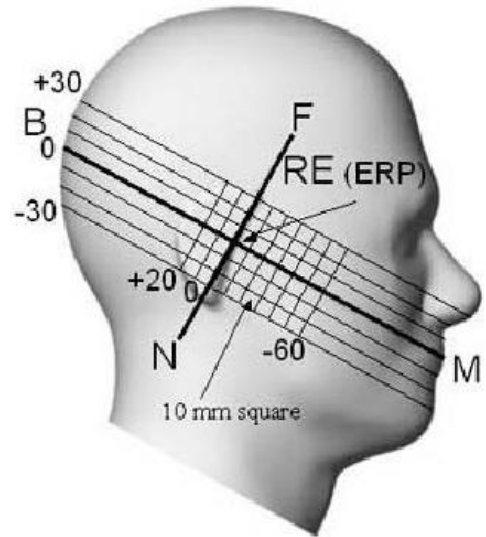

Figure 5.1 Side view of the phantom

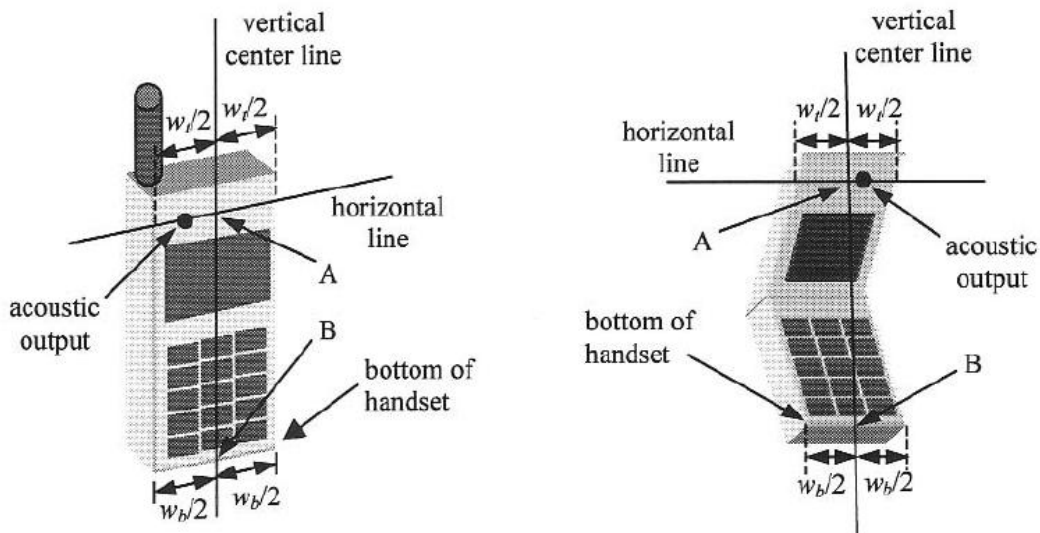

Figure 5.2 Handset vertical and horizontal reference lines

5.2 Body Holster/Belt Clip Configurations

Body-worn operating configurations are tested with the belt-clips and holsters attached to the device and positioned against a flat phantom in a normal use configuration. A device with a headset output is tested with a headset connected to the device. Body dielectric parameters are used.

Accessories for Body-worn operation configurations are divided into two categories: those that do not contain metallic components and those that contain metallic components. When multiple accessories that do not contain metallic components are supplied with the device, the device is tested with only the accessory that dictates the closest spacing to the body. Then multiple accessories that contain metallic components are tested with each accessory. If multiple accessory share an identical metallic component (i.e. the same metallic belt-clip used with different holsters with no other metallic components) only the accessory that dictates the closest spacing to the body is tested.

Body-worn accessories may not always be supplied or available as options for some Devices intended to be authorized for body-worn use. In this case, a test configuration with a separation distance between the back of the device and the flat phantom is used.

Since this EUT does not supply any body worn accessory to the end user a distance of 2.0 cm from the EUT back surface to the liquid interface is configured for the generic test.

"See the Test SET-UP Photo"

Transmitters that are designed to operate in front of a person's face, as in push-to-talk configurations, are tested for SAR compliance with the front of the device positioned to face the flat phantom. For devices that are carried next to the body such as a shoulder, waist or chest-worn transmitters, SAR compliance is tested with the accessory(ies), including headsets and microphones, attached to the device and positioned against a flat phantom in a normal use configuration.

In all cases SAR measurements are performed to investigate the worst-case positioning. Worstcase positioning is then documented and used to perform Body SAR testing.

6. MEASUREMENT UNCERTAINTY

Measurement uncertainties in SAR measurements are difficult to quantify due to several variables including biological, physiological, and environmental. However, we estimate the measurement uncertainties in SAR to be less than 15 % - 25 %.

According to ANSI/IEEE C95.3, the overall uncertainties are difficult to assess and will vary with the type of meter and usage situation. However, accuracy's of 1 to ± 3 dB can be expected in practice, with greater uncertainties in near-field situations and at higher frequencies (shorter wavelengths), or areas where large reflecting objects are present. Under optimum measurement conditions, SAR measurement uncertainties of at least ± 2 dB can be expected.

According to CENELEC, typical worst-case uncertainty of field measurements is 5 dB. For well-defined modulation characteristics the uncertainty can be reduced to ± 3 dB.

Error Description	Uncertainty value [%]	Probability Distribution	Divisor	ci	ci ²	Standard Uncertainty [%]	Stand Uncert ²	(Stand Uncert ²) X (ci ²)	Vi & Ver#
1. Measurement System									
Probe Calibration	5.5	Normal	1.00	1	1	5.50	30.25	30.25	∞
Axial Isotropy	4.7	Rectangular	1.73	0.7	0.49	2.71	7.36	3.61	∞
Hemispherical Isotropy	9.6	Rectangular	1.73	0.7	0.49	5.54	30.72	15.05	∞
Linearity	4.7	Rectangular	1.73	1	1	2.71	7.36	7.36	∞
System Detection limits	1.0	Rectangular	1.73	1	1	0.58	0.33	0.33	∞
Boundary effect	1.0	Rectangular	1.73	1	1	0.58	0.33	0.33	∞
Response time	0.8	Rectangular	1.73	1	1	0.46	0.21	0.21	∞
RF Ambient conditions	3.0	Rectangular	1.73	1	1	1.73	3.00	3.00	∞
Readout Electronics	0.3	Normal	1.00	1	1	0.30	0.09	0.09	∞
Integration time	2.6	Rectangular	1.73	1	1	1.50	2.25	2.25	∞
Probe positioner	0.4	Rectangular	1.73	1	1	0.23	0.05	0.05	∞
Probe positioning	2.9	Rectangular	1.73	1	1	1.67	2.80	2.80	∞
Maximum SAR evaluation	1.0	Rectangular	1.73	1	1	0.58	0.33	0.33	∞
Sub Total								65.69	
2. Test Sample Related									
Device Positioning	1.8	Normal	1.00	1	1	1.77	3.13	3.13	9
Device Holder	3.6	Normal	1.00	1	1	3.60	12.96	12.96	∞
Power Drift	5.0	Rectangular	1.73	1	1	2.89	8.33	8.33	∞
Sub Total								24.43	
3. Phantom and Setup									
Phantom Uncertainty	4.0	Rectangular	1.73	1	1	2.31	5.33	5.33	∞
Liquid conductivity (target)	5.0	Rectangular	1.73	0.5	0.25	2.89	8.33	2.08	∞
Liquid conductivity (measurement error)	2.5	Normal	1.00	0.5	0.25	2.50	6.25	1.56	∞
Liquid permittivity (target)	5.0	Rectangular	1.73	0.5	0.25	2.89	8.33	2.08	∞
Liquid permittivity (measurement error)	2.5	Normal	1.00	0.5	0.25	2.50	6.25	1.56	∞
Sub Total								12.63	
Combined standard uncertainty [%]						10.14		102.74	-
Expanded uncertainty [k = 2, confidence 95 %]						± 20.3 %			

Table 6.1 Breakdown of Errors

7. ANSI/ IEEE C95.1 - 2005 RF EXPOSURE LIMITS

HUMAN EXPOSURE	UNCONTROLLED ENVIRONMENT General Population (W/kg) or (mW/g)	CONTROLLED ENVIRONMENT Occupational (W/kg) or (mW/g)
SPATIAL PEAK SAR * (Brain)	1.60	8.00
SPATIAL AVERAGE SAR ** (Whole Body)	0.08	0.40
SPATIAL PEAK SAR *** (Hands / Feet / Ankle / Wrist)	4.00	20.00

Table 7.1 Safety Limits for Partial Body Exposure

NOTES:

* The Spatial Peak value of the SAR averaged over any 1 gram of tissue (defined as a tissue volume in the shape of a cube) and over the appropriate averaging time.

** The Spatial Average value of the SAR averaged over the whole-body.

*** The Spatial Peak value of the SAR averaged over any 10 grams of tissue (defined as a tissue volume in the shape of a cube) and over the appropriate averaging time.

Uncontrolled Environments are defined as locations where there is the exposure of individuals who have no knowledge or control of their exposure.

Controlled Environments are defined as locations where there is exposure that may be incurred by persons who are aware of the potential for exposure, (i.e. as a result of employment or occupation).

8. SYSTEM VERIFICATION

8.1 Tissue Verification

Freq. [MHz]	Date	Liquid	Liquid Temp[°C]	Parameters	Target Value	Measured Value	Deviation [%]	Limit [%]
835	Jan.14, 2008	Head	21.5	ϵ_r	41.5	40.9	- 1.45	± 5
				σ	0.90	0.893	- 0.78	± 5
835	Jan.14, 2008	Body	21.5	ϵ_r	55.2	53.4	- 3.26	± 5
				σ	0.97	0.99	+ 2.06	± 5
1 900	Jan.15, 2008	Head	21.3	ϵ_r	40.0	40	0.00	± 5
				σ	1.40	1.39	- 0.71	± 5
1 900	Jan.15, 2008	Body	21.3	ϵ_r	53.3	51.9	- 2.63	± 5
				σ	1.52	1.56	+ 2.63	± 5

8.2 System Validation

Prior to assessment, the system is verified to the $\pm 10\%$ of the specifications at 835 MHz/1 900 MHz by using the system validation kit. (Graphic Plots Attached)

* Input Power: 1 W

Freq. [MHz]	Date	Liquid	Liquid Temp [°C]	SAR Average	Target Value (SPEAG) (mW/g)	Measured Value (mW/g)	Deviation [%]	Limit [%]
835	Jan.14, 2008	Head	21.5	1 g	9.21	9.72	+ 5.53	± 10
1 900	Jan.15, 2008	Head	21.3	1 g	37.2	37.60	+ 1.07	± 10

9. 3G MEASUREMENT PROCEDURES

9.1 Procedures Used To Establish Test Signal

The handset was placed into a simulated call using a base station simulator in a shielded chamber. Such test signals offer a consistent means for testing SAR and are recommended for evaluating SAR. SAR measurements were taken with a fully charged battery. In order to verify that the device was tested and maintained at full power, this was configured with the base station simulator. The SAR measurement software calculates a reference point at the start and end of the test to check for power drifts. If conducted power deviations of more than 5% occurred, the tests were repeated.

9.2 SAR Measurement Conditions for CDMA2000 1x

These procedures were followed according to FCC "SAR Measurement Procedures for 3G Devices", May 2006.

9.2.1 Output Power Verification

See 3GPP2 C.S0011/TIA-98-E as recommended by "SAR Measurement Procedures for 3G Devices", May 2006. Maximum output power is verified on the High, Middle and Low channels according to procedures defined in section 4.4.5.2 of 3GPP2 C.S0011/TIA-98-E. SO55 tests were measured with power control bits in "All Up" condition.

1. If the mobile station supports Reverse TCH RC 1 and Forward TCH RC 1, set up a call using Fundamental Channel Test Mode 1 (RC=1/1) with 9 600 bps data rate only.
2. Under RC1, C.S0011 Table 4.4.5.2-1 (Table 4) parameters were applied.
3. If the MS supports the RC 3 Reverse FCH, RC3 Reverse SCH0 and demodulation of RC 3, 4, or 5, set up a call using Supplemental Channel Test Mode 3 (RC 3/3) with 9 600 bps Fundamental Channel and 9 600 bps SCH0 data rate Channel and 9 600 bps SCH0 data rate.
4. Under RC3, C.S0011 Table 4.4.5.2-2(Table 5) was applied.
5. FCHs were configured at full rate for maximum SAR with "All Up" power control bits.

Parameters for Max. Power for RC1

Parameter	Units	Value
$\overline{I_{or}}$	dBm/1.23 MHz	-104
$\frac{\text{Pilot } E_c}{I_{or}}$	dB	-7
$\frac{\text{Traffic } E_c}{I_{or}}$	dB	-7.4

Table. 9.1

Parameters for Max. Power for RC3

Parameter	Units	Value
$\overline{I_{or}}$	dBm/1.23 MHz	-86
$\frac{\text{Pilot } E_c}{I_{or}}$	dB	-7
$\frac{\text{Traffic } E_c}{I_{or}}$	dB	-7.4

Table. 9.2

9.2.2 Head SAR Measurement

SAR for head exposure configurations is measured in RC3 with the DUT configured to transmit at full rate using Loopback Service Option SO55. SAR for RC1 is not required when the maximum average output of each channel is less than ¼ dB higher than that measured in RC3. Otherwise, SAR is measured on the maximum output channel in RC1 using the exposure configuration that results in the highest SAR for that channel in RC3.

9.2.3 Body SAR Measurement

SAR for body exposure configurations is measured in RC3 with the DUT configured to transmit at full rate on FCH with all other code channels disabled using TDSO / SO32. SAR for multiple code channels (FCH + SCHn) is not required when the maximum average output of each RF channel is less than ¼ dB higher than that measured with FCH only. Otherwise, SAR is measured on the maximum output channel (FCH + SCHn) with FCH at full rate and SCH0 enabled at 9 600 bps using the exposure configuration that results in the highest SAR for that channel with FCH only. When multiple code channels are enabled, the DUT output may shift by more than 0.5 dB and lead to higher SAR drifts and SCH dropouts.

Body SAR in RC1 is not required when the maximum average output of each channel is less than ¼ dB higher than that measured in RC3. Otherwise, SAR is measured on the maximum output channel in RC1; with Loopback Service Option SO55, at full rate, using the body exposure configuration that results in the highest SAR for that channel in RC3.

9.2.4 Handsets with EV-DO

For handsets with Ev-Do capabilities, when the maximum average output of each channel in Rev. 0 is less than ¼ dB higher than that measured in RC3 (1x RTT), body SAR for Ev-Do is not required. Otherwise, SAR for Rev. 0 is measured on the maximum output channel at 153.6 kbps using the body exposure configuration that results in the highest SAR for that channel in RC3. SAR for Rev. A is not required when the maximum average output of each channel is less than that measured in Rev. 0 or less than ¼ dB higher than that measured in RC3. Otherwise, SAR is measured on the maximum output channel for Rev. A using a Reverse Data Channel payload size of 4096 bits and a Termination Target of 16 slots defined for Subtype 2 Physical Layer configurations. A Forward Traffic Channel data rate corresponding to the 2-slot version of 307.2 kbps with the ACK Channel transmitting in all slots should be configured in the downlink for both Rev. 0 and Rev. A.

Average Output Power Measurement for FCC ID: PP4EZ2

Band	Channel	SO2	SO2	SO55	SO55	TDSO
		RC1/1	RC3/3	RC1/1	RC3/3	RC3/3
CDMA	1013	24.82	24.87	24.91	24.93	24.98
	384	24.92	24.97	24.99	25.00	25.08
	777	24.93	24.94	24.89	24.94	24.99
PCS	25	25.01	25.00	25.01	25.04	25.10
	600	24.97	24.95	24.97	25.00	25.06
	1175	24.94	24.95	24.96	24.97	25.04

10. SAR TEST DATA SUMMARY

10.1 Measurement Results (CDMA835 Head SAR Touch)

Frequency		Modulation	Conducted Power (dBm)		Battery	Phantom Position	Antenna Type	SAR(mW/g)
MHz	Channel.		Begin	End				
824.70	1013 (Low)	CDMA835	24.93	24.93	Standard	Left Ear	Intenna	0.933
836.52	384 (Mid)	CDMA835	25.00	24.96	Standard	Left Ear	Intenna	1.20
848.31	777 (High)	CDMA835	24.94	24.80	Standard	Left Ear	Intenna	1.15
824.70	1013 (Low)	CDMA835	24.93	25.08	Standard	Right Ear	Intenna	0.757
836.52	384 (Mid)	CDMA835	25.00	24.94	Standard	Right Ear	Intenna	0.904
848.31	777 (High)	CDMA835	24.94	24.88	Standard	Right Ear	Intenna	1.01
836.52	384 (Mid)	CDMA835	25.00	25.15	Extended	Left Ear	Intenna	*1.18
ANSI/ IEEE C95.1 2005 – Safety Limit						Head		
Spatial Peak						1.6 W/kg (mW/g)		
Uncontrolled Exposure/ General Population						<small>Averaged over 1 gram</small>		

NOTES:

- 1 The test data reported are the worst-case SAR value with the antenna-head position set in a typical configuration. Test procedures used are according to FCC/OET Bulletin 65, Supplement C [July 2001].
- 2 All modes of operation were investigated and the worst-case are reported.
- 3 Measured Depth of Simulating Tissue is 15.0 ± 0.2 cm.
- 4 Tissue parameters and temperatures are listed on the SAR plot.
- 5 Battery Type Standard Extended Slim
Batteries are fully charged for all readings.
- 6 Test Signal Call Mode Manual Test cord Base Station Simulator
- 7 Head SAR was tested under RC3/SO55.
- 8 Highest SAR value measurement in this band repeated with *Extended battery

10.2 Measurement Results (CDMA835 Head SAR Tilt)

Frequency		Modulation	Conducted Power (dBm)		Battery	Phantom Position	Antenna Type	SAR(mW/g)
MHz	Channel.		Begin	End				
836.52	384 (Mid)	CDMA835	25.00	25.09	Standard	Left Tilt 15°	Intenna	0.283
836.52	384 (Mid)	CDMA835	25.00	25.03	Standard	Right Tilt 15°	Intenna	0.280
ANSI/ IEEE C95.1 2005 – Safety Limit						Head		
Spatial Peak						1.6 W/kg (mW/g)		
Uncontrolled Exposure/ General Population						<small>Averaged over 1 gram</small>		

NOTES:

- The test data reported are the worst-case SAR value with the antenna-head position set in a typical configuration. Test procedures used are according to FCC/OET Bulletin 65, Supplement C [July 2001].
- All modes of operation were investigated and the worst-case are reported.
- Measured Depth of Simulating Tissue is 15.0 ± 0.2 cm.
- Tissue parameters and temperatures are listed on the SAR plot.
- Battery Type Standard Extended Slim
Batteries are fully charged for all readings.
- Test Signal Call Mode Manual Test cord Base Station Simulator
- Head SAR was tested under RC3/SO55.
- Justification for reduced test configurations: per FCC/OET Supplement C (July, 2001), if the SAR measured at the middle channel for each test configuration (Left, right, cheek/touch, tilt/ear, extended and retracted) is at least 3.0 dB lower than the SAR limit, testing at the high and low channels is optional for such test configuration(s).

10.3 Measurement Results (PCS1900 Head SAR Touch)

Frequency		Modulation	Conducted Power (dBm)		Battery	Phantom Position	Antenna Type	SAR(mW/g)
MHz	Channel.		Begin	End				
1 851.25	25 (Low)	PCS1900	25.04	24.86	Standard	Left Ear	Intenna	0.714
1 880.00	600 (Mid)	PCS1900	25.00	25.09	Standard	Left Ear	Intenna	0.972
1 908.75	1175 (High)	PCS1900	24.97	24.87	Standard	Left Ear	Intenna	0.690
1 851.25	25 (Low)	PCS1900	25.04	25.07	Standard	Right Ear	Intenna	0.435
1 880.00	600 (Mid)	PCS1900	25.00	25.04	Standard	Right Ear	Intenna	0.635
1 908.75	1175 (High)	PCS1900	24.97	25.06	Standard	Right Ear	Intenna	0.298
1 880.00	600 (Mid)	PCS1900	25.00	25.03	Extended	Left Ear	Intenna	*0.913
ANSI/ IEEE C95.1 2005 – Safety Limit						Head		
Spatial Peak						1.6 W/kg (mW/g)		
Uncontrolled Exposure/ General Population						<small>Averaged over 1 gram</small>		

NOTES:

- 1 The test data reported are the worst-case SAR value with the antenna-head position set in a typical configuration. Test procedures used are according to FCC/OET Bulletin 65, Supplement C [July 2001].
- 2 All modes of operation were investigated and the worst-case are reported.
- 3 Measured Depth of Simulating Tissue is 15.0 ± 0.2 cm.
- 4 Tissue parameters and temperatures are listed on the SAR plot.
- 5 Battery Type Standard Extended Slim
 Batteries are fully charged for all readings.
- 6 Test Signal Call Mode Manual Test cord Base Station Simulator
- 7 Head SAR was tested under RC3/SO55.
- 8 Highest SAR value measurement in this band repeated with *Extended battery

10.4 Measurement Results (PCS1900 Head SAR Tilt)

Frequency		Modulation	Conducted Power (dBm)		Battery	Phantom Position	Antenna Type	SAR(mW/g)
MHz	Channel.		Begin	End				
1 880.00	600 (Mid)	PCS1900	25.00	25.03	Standard	Left Tilt 15°	Intenna	0.128
1 880.00	600 (Mid)	PCS1900	25.00	24.87	Standard	Right Tilt 15°	Intenna	0.091
ANSI/ IEEE C95.1 2005 – Safety Limit						Head		
Spatial Peak						1.6 W/kg (mW/g)		
Uncontrolled Exposure/ General Population						<small>Averaged over 1 gram</small>		

NOTES:

- 1 The test data reported are the worst-case SAR value with the antenna-head position set in a typical configuration. Test procedures used are according to FCC/OET Bulletin 65, Supplement C [July 2001].
- 2 All modes of operation were investigated and the worst-case are reported.
- 3 Measured Depth of Simulating Tissue is 15.0 ± 0.2 cm.
- 4 Tissue parameters and temperatures are listed on the SAR plot.
- 5 Battery Type Standard Extended Slim
Batteries are fully charged for all readings.
- 6 Test Signal Call Mode Manual Test cord Base Station Simulator
- 7 Head SAR was tested under RC3/SO55.
- 8 Justification for reduced test configurations: per FCC/OET Supplement C (July, 2001), if the SAR measured at the middle channel for each test configuration (Left, right, cheek/touch, tilt/ear, extended and retracted) is at least 3.0 dB lower than the SAR limit, testing at the high and low channels is optional for such test configuration(s).

11. CONCLUSION

The SAR measurement indicates that the EUT complies with the RF radiation exposure limits of the ANSI/IEEE C95.1 2005.

These measurements are taken to simulate the RF effects exposure under worst-case conditions. Precise laboratory measures were taken to assure repeatability of the tests.

12. REFERENCES

- [1] Federal Communications Commission, OET Bulletin 65 (Edition 97-01), Supplement C (Edition 01-01), Evaluating Compliance with FCC Guidelines for Human Exposure to Radio frequency Electromagnetic Fields, July 2001.
- [2] IEEE Standards Coordinating Committee 34 – IEEE Std. 1528-2003, IEEE Recommended Practice for Determining the Peak Spatial-Average Specific Absorption Rate (SAR) in the Human Body from Wireless Communications Devices.
- [3] Federal Communications Commission, ET Docket 93-62, Guidelines for Evaluating the Environmental Effects of Radio frequency Radiation, Aug. 1996.
- [4] ANSI/IEEE C95.1 - 1991, American National Standard safety levels with respect to human exposure to radio frequency electromagnetic fields, 300kHz to 100GHz, New York: IEEE, Aug. 1992
- [5] ANSI/IEEE C95.3 - 1991, IEEE Recommended Practice for the Measurement of Potentially Hazardous Electromagnetic Fields - RF and Microwave, New York: IEEE, 1992.
- [6] NCRP, National Council on Radiation Protection and Measurements, Biological Effects and Exposure Criteria for Radio Frequency Electromagnetic Fields, NCRP Report No. 86, 1986. Reprinted Feb. 1995.
- [7] T. Schmid, O. Egger, N. Kuster, Automated E-field scanning system for dosimetric assessments, IEEE Transaction on Microwave Theory and Techniques, vol. 44, Jan. 1996, pp. 105-113.
- [8] K. Pokovic, T. Schmid, N. Kuster, Robust setup for precise calibration of E-field probes in tissue simulating liquids at mobile communications frequencies, ICECOM97, Oct. 1997, pp. 120-124.
- [9] K. Pokovic, T. Schmid, and N. Kuster, E-field Probe with improved isotropy in brain simulating liquids, Proceedings of the ELMAR, Zadar, Croatia, June 23-25, 1996, pp. 172-175.
- [10] Schmid & Partner Engineering AG, Application Note: Data Storage and Evaluation, June 1998, p2.
- [11] V. Hombach, K. Meier, M. Burkhardt, E. Kuhn, N. Kuster, The Dependence of EM Energy Absorption upon Human Head Modeling at 900 MHz, IEEE Transaction on Microwave Theory and Techniques, vol. 44 no. 10, Oct. 1996, pp. 1865-1873.
- [12] N. Kuster and Q. Balzano, Energy absorption mechanism by biological bodies in the near field of dipole antennas above 300MHz, IEEE Transaction on Vehicular Technology, vol. 41, no. 1, Feb. 1992, pp. 17-23.
- [13] G. Hartsgrrove, A. Kraszewski, A. Surowiec, Simulated Biological Materials for Electromagnetic Radiation Absorption Studies, University of Ottawa, Bioelectro magnetics, Canada: 1987, pp. 29-36.
- [14] Q. Balzano, O. Garay, T. Manning Jr., Electromagnetic Energy Exposure of Simulated Users of Portable Cellular Telephones, IEEE Transactions on Vehicular Technology, vol. 44, no.3, Aug. 1995.
- [15] W. Gander, Computer mathematick, Birkhaeuser, Basel, 1992.
- [16] W.H. Press, S.A. Teukolsky, W.T. Vetterling, and B.P. Flannery, Numerical Recipes in C, The Art of Scientific Computing, Second edition, Cambridge University Press, 1992.
- [17] Federal Communications Commission, OET Bulletin 65, Evaluating Compliance with FCC Guidelines for Human Exposure to Radiofrequency Electromagnetic Fields. Supplement C, Dec. 1997.
- [18] N. Kuster, R. Kastle, T. Schmid, Dosimetric evaluation of mobile communications equipment with known precision, IEEE Transaction on Communications, vol. E80-B, no. 5, May 1997, pp. 645-652.
- [19] CENELEC CLC/SC111B, European Prestandard (prENV 50166-2), Human Exposure to Electromagnetic Fields High-frequency: 10kHz-300GHz, Jan. 1995.
- [20] Prof. Dr. Niels Kuster, ETH, Eidgenössische Technische Hochschule Zürich, Dosimetric Evaluation of the Cellular Phone.

Attachment 1. – SAR Test Plots

Test Laboratory: HCT CO., LTD.
EUT Type: Dual-Band CDMA Phone (CDMA/PCS CDMA)
Liquid Temperature: 21.5 °C
Ambient Temperature: 21.7 °C
Test Date: Jan.14, 2008

DUT: EZ2; Type: Folder; Serial: #1

Communication System: CDMA 835MHz FCC; Frequency: 824.7 MHz;Duty Cycle: 1:1
Medium parameters used: $f = 825$ MHz; $\sigma = 0.885$ mho/m; $\epsilon_r = 40.9$; $\rho = 1000$ kg/m³
Phantom section: Left Section ; Measurement SW: DASY4, V4.6 Build 23; Postprocessing SW: SEMCAD, V1.8 Build 176

DASY4 Configuration:

- Probe: ET3DV6 - SN1609; ConvF(6.81, 6.81, 6.81); Calibrated: 2007-08-30
- Sensor-Surface: 4mm (Mechanical Surface Detection)
- Electronics: DAE3 Sn466; Calibrated: 2007-01-25
- Phantom: 835/900 Phantom ; Type: SAM

Left touch 1013/Area Scan (51x111x1): Measurement grid: dx=15mm, dy=15mm
Maximum value of SAR (interpolated) = 0.868 mW/g

Left touch 1013/Zoom Scan (5x5x7)/Cube 0: Measurement grid: dx=8mm, dy=8mm, dz=5mm
Reference Value = 18.6 V/m; Power Drift = -0.003 dB
Peak SAR (extrapolated) = 2.17 W/kg
SAR(1 g) = 0.933 mW/g; SAR(10 g) = 0.516 mW/g
Maximum value of SAR (measured) = 1.15 mW/g

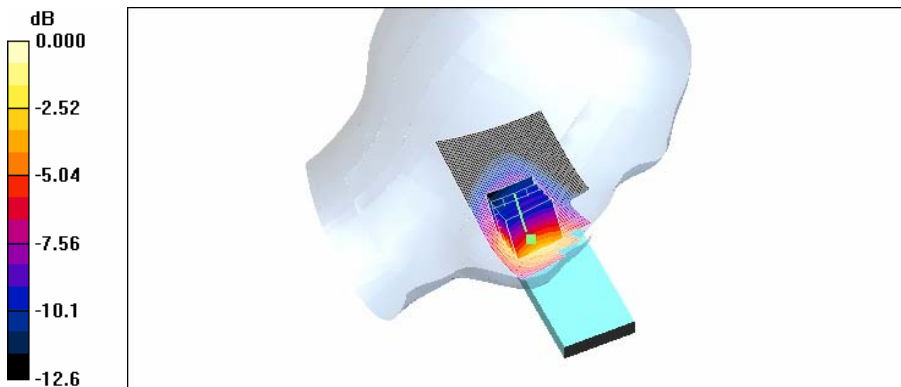

Test Laboratory: HCT CO., LTD.
EUT Type: Dual-Band CDMA Phone (CDMA/PCS CDMA)
Liquid Temperature: 21.5 °C
Ambient Temperature: 21.7 °C
Test Date: Jan.14, 2008

DUT: EZ2; Type: Folder; Serial: #1

Communication System: CDMA 835MHz FCC; Frequency: 836.52 MHz; Duty Cycle: 1:1
Medium parameters used (interpolated): $f = 836.52$ MHz; $\sigma = 0.895$ mho/m; $\epsilon_r = 40.8$; $\rho = 1000$ kg/m³
Phantom section: Left Section ; Measurement SW: DASY4, V4.6 Build 23; Postprocessing SW: SEMCAD, V1.8 Build 176

DASY4 Configuration:

- Probe: ET3DV6 - SN1609; ConvF(6.81, 6.81, 6.81); Calibrated: 2007-08-30
- Sensor-Surface: 4mm (Mechanical Surface Detection)
- Electronics: DAE3 Sn466; Calibrated: 2007-01-25
- Phantom: 835/900 Phantom ; Type: SAM

Left touch 384/Area Scan (51x111x1): Measurement grid: dx=15mm, dy=15mm

[Info: Interpolated medium parameters used for SAR evaluation.](#)

Maximum value of SAR (interpolated) = 1.11 mW/g

Left touch 384/Zoom Scan (5x5x7)/Cube 0: Measurement grid: dx=8mm, dy=8mm, dz=5mm

Reference Value = 22.1 V/m; Power Drift = -0.039 dB

Peak SAR (extrapolated) = 2.79 W/kg

SAR(1 g) = 1.2 mW/g; SAR(10 g) = 0.668 mW/g

[Info: Interpolated medium parameters used for SAR evaluation.](#)

Maximum value of SAR (measured) = 1.48 mW/g

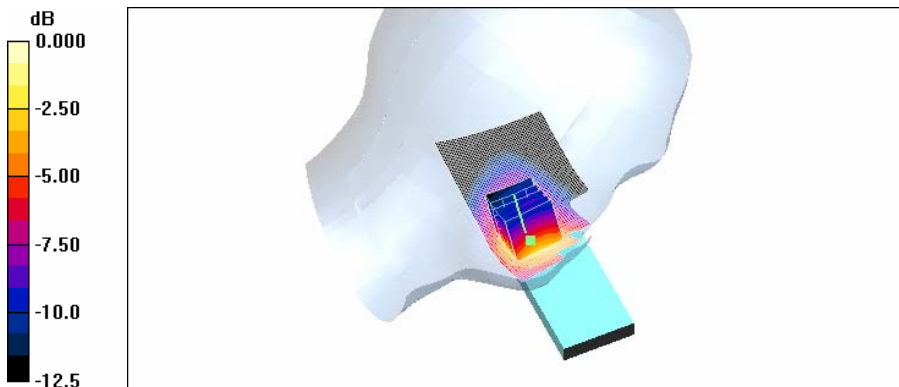

0 dB = 1.48mW/g

Test Laboratory: HCT CO., LTD.
EUT Type: Dual-Band CDMA Phone (CDMA/PCS CDMA)
Liquid Temperature: 21.5 °C
Ambient Temperature: 21.7 °C
Test Date: Jan.14, 2008

DUT: EZ2; Type: Folder; Serial: #1

Communication System: CDMA 835MHz FCC; Frequency: 848.31 MHz; Duty Cycle: 1:1
Medium parameters used (interpolated): $f = 848.31$ MHz; $\sigma = 0.904$ mho/m; $\epsilon_r = 40.7$; $\rho = 1000$ kg/m³
Phantom section: Left Section ; Measurement SW: DASY4, V4.6 Build 23; Postprocessing SW: SEMCAD, V1.8 Build 176

DASY4 Configuration:

- Probe: ET3DV6 - SN1609; ConvF(6.81, 6.81, 6.81); Calibrated: 2007-08-30
- Sensor-Surface: 4mm (Mechanical Surface Detection)
- Electronics: DAE3 Sn466; Calibrated: 2007-01-25
- Phantom: 835/900 Phamtom ; Type: SAM

Left touch 777/Area Scan (51x111x1): Measurement grid: dx=15mm, dy=15mm

[Info: Interpolated medium parameters used for SAR evaluation.](#)

Maximum value of SAR (interpolated) = 1.06 mW/g

Left touch 777/Zoom Scan (5x5x7)/Cube 0: Measurement grid: dx=8mm, dy=8mm, dz=5mm

Reference Value = 23.0 V/m; Power Drift = -0.143 dB

Peak SAR (extrapolated) = 2.51 W/kg

SAR(1 g) = 1.15 mW/g; SAR(10 g) = 0.654 mW/g

[Info: Interpolated medium parameters used for SAR evaluation.](#)

Maximum value of SAR (measured) = 1.23 mW/g

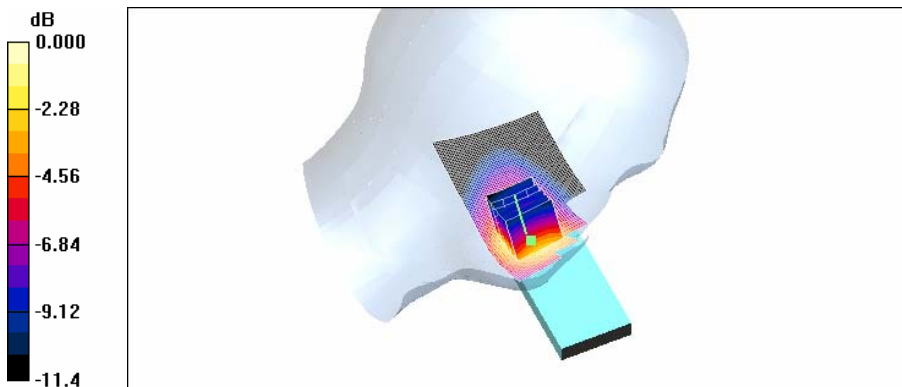

0 dB = 1.23mW/g

Test Laboratory: HCT CO., LTD.
EUT Type: Dual-Band CDMA Phone (CDMA/PCS CDMA)
Liquid Temperature: 21.5 °C
Ambient Temperature: 21.7 °C
Test Date: Jan.14, 2008

DUT: EZ2; Type: Folder; Serial: #1

Communication System: CDMA 835MHz FCC; Frequency: 824.7 MHz;Duty Cycle: 1:1
Medium parameters used: $f = 825$ MHz; $\sigma = 0.885$ mho/m; $\epsilon_r = 40.9$; $\rho = 1000$ kg/m³
Phantom section: Right Section ; Measurement SW: DASY4, V4.6 Build 23; Postprocessing SW: SEMCAD, V1.8 Build 176

DASY4 Configuration:

- Probe: ET3DV6 - SN1609; ConvF(6.81, 6.81, 6.81); Calibrated: 2007-08-30
- Sensor-Surface: 4mm (Mechanical Surface Detection)
- Electronics: DAE3 Sn466; Calibrated: 2007-01-25
- Phantom: 835/900 Phantom ; Type: SAM

Right touch 1013/Area Scan (51x111x1): Measurement grid: dx=15mm, dy=15mm
Maximum value of SAR (interpolated) = 0.831 mW/g

Right touch 1013/Zoom Scan (5x5x7)/Cube 0: Measurement grid: dx=8mm, dy=8mm, dz=5mm
Reference Value = 25.2 V/m; Power Drift = 0.152 dB
Peak SAR (extrapolated) = 1.27 W/kg
SAR(1 g) = 0.757 mW/g; SAR(10 g) = 0.487 mW/g
Maximum value of SAR (measured) = 0.824 mW/g

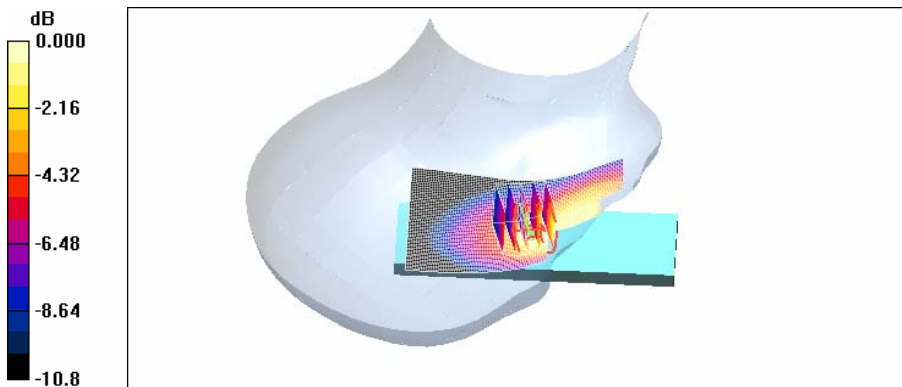

0 dB = 0.824mW/g

Test Laboratory: HCT CO., LTD.
EUT Type: Dual-Band CDMA Phone (CDMA/PCS CDMA)
Liquid Temperature: 21.5 °C
Ambient Temperature: 21.7 °C
Test Date: Jan.14, 2008

DUT: EZ2; Type: Folder; Serial: #1

Communication System: CDMA 835MHz FCC; Frequency: 836.52 MHz; Duty Cycle: 1:1
Medium parameters used (interpolated): $f = 836.52$ MHz; $\sigma = 0.895$ mho/m; $\epsilon_r = 40.8$; $\rho = 1000$ kg/m³
Phantom section: Right Section ; Measurement SW: DASY4, V4.6 Build 23; Postprocessing SW: SEMCAD, V1.8 Build 176

DASY4 Configuration:

- Probe: ET3DV6 - SN1609; ConvF(6.81, 6.81, 6.81); Calibrated: 2007-08-30
- Sensor-Surface: 4mm (Mechanical Surface Detection)
- Electronics: DAE3 Sn466; Calibrated: 2007-01-25
- Phantom: 835/900 Phantom ; Type: SAM

Right touch 384/Area Scan (51x111x1): Measurement grid: dx=15mm, dy=15mm

[Info: Interpolated medium parameters used for SAR evaluation.](#)

Maximum value of SAR (interpolated) = 1.01 mW/g

Right touch 384/Zoom Scan (5x5x7)/Cube 0: Measurement grid: dx=8mm, dy=8mm, dz=5mm

Reference Value = 27.4 V/m; Power Drift = -0.056 dB

Peak SAR (extrapolated) = 1.50 W/kg

SAR(1 g) = 0.904 mW/g; SAR(10 g) = 0.596 mW/g

[Info: Interpolated medium parameters used for SAR evaluation.](#)

Maximum value of SAR (measured) = 1.02 mW/g

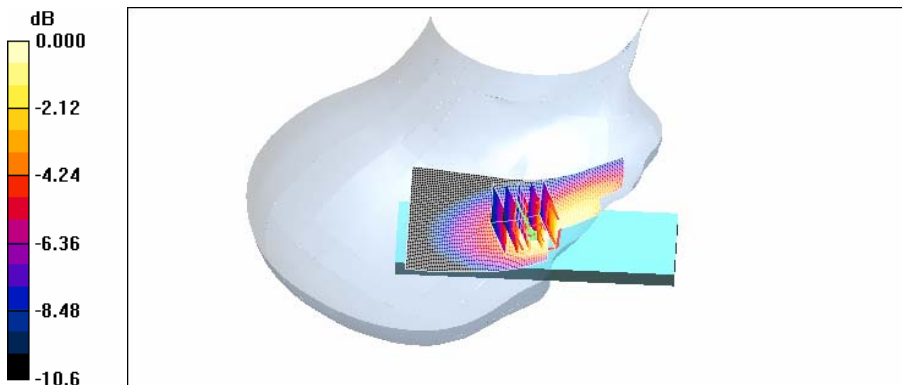

Test Laboratory: HCT CO., LTD.
EUT Type: Dual-Band CDMA Phone (CDMA/PCS CDMA)
Liquid Temperature: 21.5 °C
Ambient Temperature: 21.7 °C
Test Date: Jan.14, 2008

DUT: EZ2; Type: Folder; Serial: #1

Communication System: CDMA 835MHz FCC; Frequency: 848.31 MHz; Duty Cycle: 1:1
Medium parameters used (interpolated): $f = 848.31$ MHz; $\sigma = 0.904$ mho/m; $\epsilon_r = 40.7$; $\rho = 1000$ kg/m³
Phantom section: Right Section ; Measurement SW: DASY4, V4.6 Build 23; Postprocessing SW: SEMCAD, V1.8 Build 176

DASY4 Configuration:

- Probe: ET3DV6 - SN1609; ConvF(6.81, 6.81, 6.81); Calibrated: 2007-08-30
- Sensor-Surface: 4mm (Mechanical Surface Detection)
- Electronics: DAE3 Sn466; Calibrated: 2007-01-25
- Phantom: 835/900 Phantom ; Type: SAM

Right touch 777/Area Scan (51x111x1): Measurement grid: dx=15mm, dy=15mm

[Info: Interpolated medium parameters used for SAR evaluation.](#)

Maximum value of SAR (interpolated) = 1.12 mW/g

Right touch 777/Zoom Scan (5x5x7)/Cube 0: Measurement grid: dx=8mm, dy=8mm, dz=5mm

Reference Value = 28.6 V/m; Power Drift = -0.059 dB

Peak SAR (extrapolated) = 1.65 W/kg

SAR(1 g) = 1.01 mW/g; SAR(10 g) = 0.651 mW/g

[Info: Interpolated medium parameters used for SAR evaluation.](#)

Maximum value of SAR (measured) = 1.11 mW/g

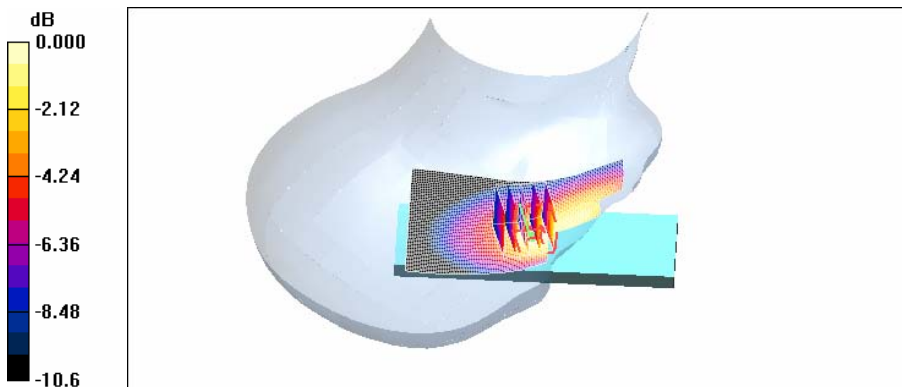

0 dB = 1.11mW/g

Test Laboratory: HCT CO., LTD.
EUT Type: Dual-Band CDMA Phone (CDMA/PCS CDMA)
Liquid Temperature: 21.5 °C
Ambient Temperature: 21.7 °C
Test Date: Jan.14, 2008
Option: Extended battery

DUT: EZ2; Type: Folder; Serial: #1

Communication System: CDMA 835MHz FCC; Frequency: 836.52 MHz; Duty Cycle: 1:1
Medium parameters used (interpolated): $f = 836.52$ MHz; $\sigma = 0.895$ mho/m; $\epsilon_r = 40.8$; $\rho = 1000$ kg/m³
Phantom section: Left Section ; Measurement SW: DASY4, V4.6 Build 23; Postprocessing SW: SEMCAD, V1.8 Build 176

DASY4 Configuration:

- Probe: ET3DV6 - SN1609; ConvF(6.81, 6.81, 6.81); Calibrated: 2007-08-30
- Sensor-Surface: 4mm (Mechanical Surface Detection)
- Electronics: DAE3 Sn466; Calibrated: 2007-01-25
- Phantom: 835/900 Phantom ; Type: SAM

Left touch 384/Area Scan (51x111x1): Measurement grid: dx=15mm, dy=15mm

[Info: Interpolated medium parameters used for SAR evaluation.](#)

Maximum value of SAR (interpolated) = 1.00 mW/g

Left touch 384/Zoom Scan (5x5x7)/Cube 0: Measurement grid: dx=8mm, dy=8mm, dz=5mm

Reference Value = 21.8 V/m; Power Drift = 0.152 dB

Peak SAR (extrapolated) = 2.60 W/kg

SAR(1 g) = 1.18 mW/g; SAR(10 g) = 0.656 mW/g

[Info: Interpolated medium parameters used for SAR evaluation.](#)

Maximum value of SAR (measured) = 1.37 mW/g

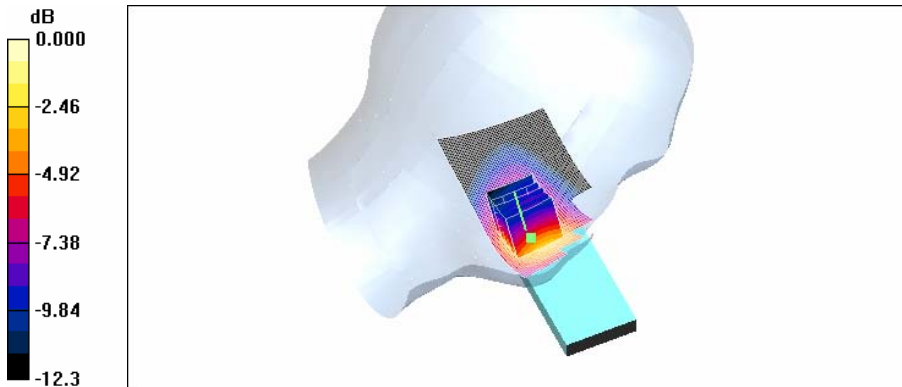

0 dB = 1.37mW/g

Test Laboratory: HCT CO., LTD.
EUT Type: Dual-Band CDMA Phone (CDMA/PCS CDMA)
Liquid Temperature: 21.5 °C
Ambient Temperature: 21.7 °C
Test Date: Jan.14, 2008

DUT: EZ2; Type: Folder; Serial: #1

Communication System: CDMA 835MHz FCC; Frequency: 836.52 MHz; Duty Cycle: 1:1
Medium parameters used (interpolated): $f = 836.52$ MHz; $\sigma = 0.895$ mho/m; $\epsilon_r = 40.8$; $\rho = 1000$ kg/m³
Phantom section: Left Section ; Measurement SW: DASY4, V4.6 Build 23; Postprocessing SW: SEMCAD, V1.8 Build 176

DASY4 Configuration:

- Probe: ET3DV6 - SN1609; ConvF(6.81, 6.81, 6.81); Calibrated: 2007-08-30
- Sensor-Surface: 4mm (Mechanical Surface Detection)
- Electronics: DAE3 Sn466; Calibrated: 2007-01-25
- Phantom: 835/900 Phantom ; Type: SAM

Left tilt 384/Area Scan (51x111x1): Measurement grid: dx=15mm, dy=15mm

[Info: Interpolated medium parameters used for SAR evaluation.](#)

Maximum value of SAR (interpolated) = 0.301 mW/g

Left tilt 384/Zoom Scan (5x5x7)/Cube 0: Measurement grid: dx=8mm, dy=8mm, dz=5mm

Reference Value = 17.5 V/m; Power Drift = 0.087 dB

Peak SAR (extrapolated) = 0.338 W/kg

SAR(1 g) = 0.283 mW/g; SAR(10 g) = 0.221 mW/g

[Info: Interpolated medium parameters used for SAR evaluation.](#)

Maximum value of SAR (measured) = 0.295 mW/g

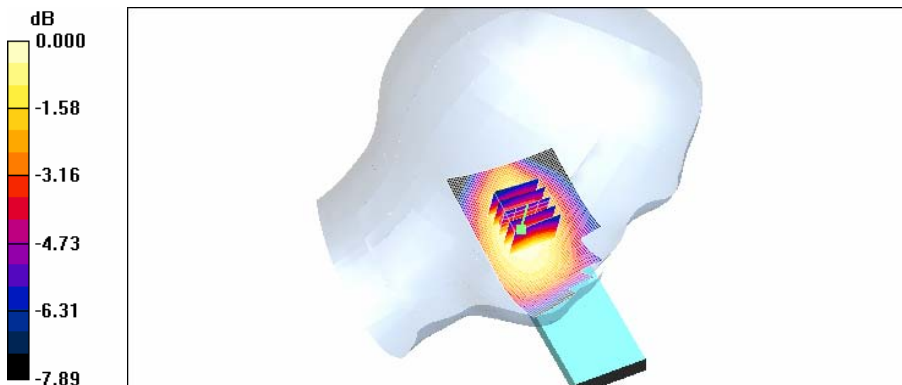

0 dB = 0.295mW/g

Test Laboratory: HCT CO., LTD.
EUT Type: Dual-Band CDMA Phone (CDMA/PCS CDMA)
Liquid Temperature: 21.5 °C
Ambient Temperature: 21.7 °C
Test Date: Jan.14, 2008

DUT: EZ2; Type: Folder; Serial: #1

Communication System: CDMA 835MHz FCC; Frequency: 836.52 MHz; Duty Cycle: 1:1
Medium parameters used (interpolated): $f = 836.52$ MHz; $\sigma = 0.895$ mho/m; $\epsilon_r = 40.8$; $\rho = 1000$ kg/m³
Phantom section: Right Section ; Measurement SW: DASY4, V4.6 Build 23; Postprocessing SW: SEMCAD, V1.8 Build 176

DASY4 Configuration:

- Probe: ET3DV6 - SN1609; ConvF(6.81, 6.81, 6.81); Calibrated: 2007-08-30
- Sensor-Surface: 4mm (Mechanical Surface Detection)
- Electronics: DAE3 Sn466; Calibrated: 2007-01-25
- Phantom: 835/900 Phantom ; Type: SAM

Right tilt 384/Area Scan (51x111x1): Measurement grid: dx=15mm, dy=15mm

[Info: Interpolated medium parameters used for SAR evaluation.](#)

Maximum value of SAR (interpolated) = 0.297 mW/g

Right tilt 384/Zoom Scan (5x5x7)/Cube 0: Measurement grid: dx=8mm, dy=8mm, dz=5mm

Reference Value = 18.1 V/m; Power Drift = 0.032 dB

Peak SAR (extrapolated) = 0.320 W/kg

SAR(1 g) = 0.280 mW/g; SAR(10 g) = 0.222 mW/g

[Info: Interpolated medium parameters used for SAR evaluation.](#)

Maximum value of SAR (measured) = 0.291 mW/g

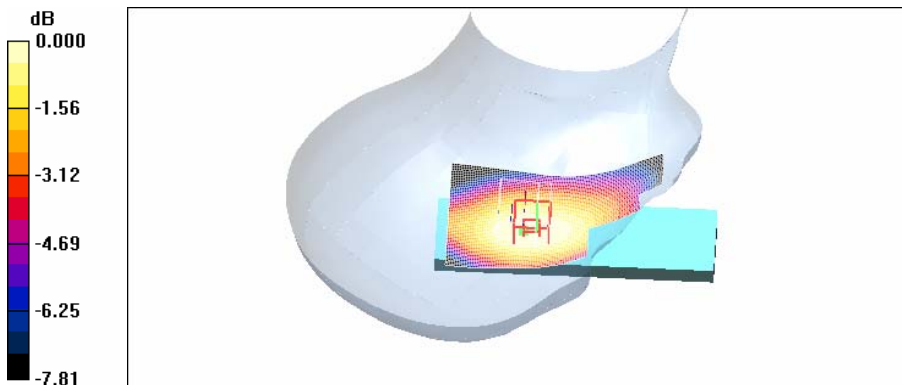

0 dB = 0.291mW/g

Test Laboratory: HCT CO., LTD.
EUT Type: Dual-Band CDMA Phone (CDMA/PCS CDMA)
Liquid Temperature: 21.3 °C
Ambient Temperature: 21.5 °C
Test Date: Jan.15, 2008

DUT: EZ2; Type: Folder; Serial: #1

Communication System: PCS 1900; Frequency: 1851.25 MHz; Duty Cycle: 1:1
Medium parameters used (interpolated): $f = 1851.25$ MHz; $\sigma = 1.34$ mho/m; $\epsilon_r = 40.1$; $\rho = 1000$ kg/m³
Phantom section: Left Section ; Measurement SW: DASY4, V4.6 Build 23; Postprocessing SW: SEMCAD, V1.8 Build 176

DASY4 Configuration:

- Probe: ET3DV6 - SN1609; ConvF(5.36, 5.36, 5.36); Calibrated: 2007-08-30
- Sensor-Surface: 4mm (Mechanical Surface Detection)
- Electronics: DAE3 Sn466; Calibrated: 2007-01-25
- Phantom: 1800/1900 Phantom; Type: SAM

Left touch 25/Area Scan (51x111x1): Measurement grid: dx=15mm, dy=15mm

[Info: Interpolated medium parameters used for SAR evaluation.](#)

Maximum value of SAR (interpolated) = 0.772 mW/g

Left touch 25/Zoom Scan (5x5x7)/Cube 0: Measurement grid: dx=8mm, dy=8mm, dz=5mm

Reference Value = 6.51 V/m; Power Drift = -0.182 dB

Peak SAR (extrapolated) = 1.10 W/kg

SAR(1 g) = 0.714 mW/g; SAR(10 g) = 0.421 mW/g

[Info: Interpolated medium parameters used for SAR evaluation.](#)

Maximum value of SAR (measured) = 0.786 mW/g

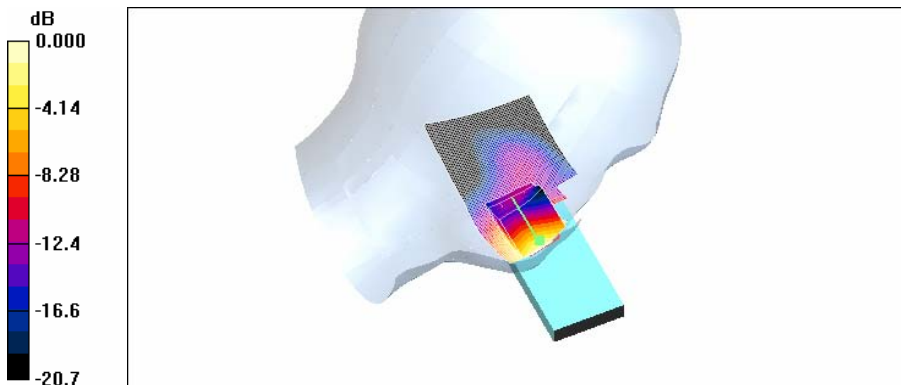

0 dB = 0.786mW/g

Test Laboratory: HCT CO., LTD.
EUT Type: Dual-Band CDMA Phone (CDMA/PCS CDMA)
Liquid Temperature: 21.3 °C
Ambient Temperature: 21.5 °C
Test Date: Jan.15, 2008

DUT: EZ2; Type: Folder; Serial: #1

Communication System: PCS 1900; Frequency: 1880 MHz; Duty Cycle: 1:1
Medium parameters used: $f = 1880$ MHz; $\sigma = 1.37$ mho/m; $\epsilon_r = 40$; $\rho = 1000$ kg/m³
Phantom section: Left Section ; Measurement SW: DASY4, V4.6 Build 23; Postprocessing SW: SEMCAD, V1.8 Build 176

DASY4 Configuration:

- Probe: ET3DV6 - SN1609; ConvF(5.36, 5.36, 5.36); Calibrated: 2007-08-30
- Sensor-Surface: 4mm (Mechanical Surface Detection)
- Electronics: DAE3 Sn466; Calibrated: 2007-01-25
- Phantom: 1800/1900 Phantom; Type: SAM

Left touch 600/Area Scan (51x111x1): Measurement grid: dx=15mm, dy=15mm
Maximum value of SAR (interpolated) = 1.01 mW/g

Left touch 600/Zoom Scan (5x5x7)/Cube 0: Measurement grid: dx=8mm, dy=8mm, dz=5mm
Reference Value = 7.71 V/m; Power Drift = 0.093 dB
Peak SAR (extrapolated) = 1.51 W/kg
SAR(1 g) = 0.972 mW/g; SAR(10 g) = 0.577 mW/g
Maximum value of SAR (measured) = 1.06 mW/g

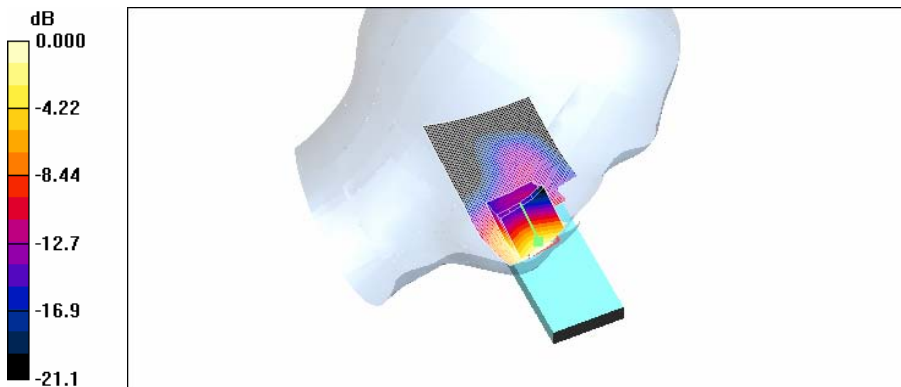

0 dB = 1.06mW/g

Test Laboratory: HCT CO., LTD.
EUT Type: Dual-Band CDMA Phone (CDMA/PCS CDMA)
Liquid Temperature: 21.3 °C
Ambient Temperature: 21.5 °C
Test Date: Jan.15, 2008

DUT: EZ2; Type: Folder; Serial: #1

Communication System: PCS 1900; Frequency: 1908.75 MHz; Duty Cycle: 1:1
Medium parameters used (interpolated): $f = 1908.75$ MHz; $\sigma = 1.4$ mho/m; $\epsilon_r = 40$; $\rho = 1000$ kg/m³
Phantom section: Left Section ; Measurement SW: DASY4, V4.6 Build 23; Postprocessing SW: SEMCAD, V1.8 Build 176

DASY4 Configuration:

- Probe: ET3DV6 - SN1609; ConvF(5.36, 5.36, 5.36); Calibrated: 2007-08-30
- Sensor-Surface: 4mm (Mechanical Surface Detection)
- Electronics: DAE3 Sn466; Calibrated: 2007-01-25
- Phantom: 1800/1900 Phantom; Type: SAM

Left touch 1175/Area Scan (51x111x1): Measurement grid: dx=15mm, dy=15mm

[Info: Interpolated medium parameters used for SAR evaluation.](#)

Maximum value of SAR (interpolated) = 0.728 mW/g

Left touch 1175/Zoom Scan (5x5x7)/Cube 0: Measurement grid: dx=8mm, dy=8mm, dz=5mm

Reference Value = 7.54 V/m; Power Drift = -0.102 dB

Peak SAR (extrapolated) = 1.10 W/kg

SAR(1 g) = 0.690 mW/g; SAR(10 g) = 0.398 mW/g

[Info: Interpolated medium parameters used for SAR evaluation.](#)

Maximum value of SAR (measured) = 0.758 mW/g

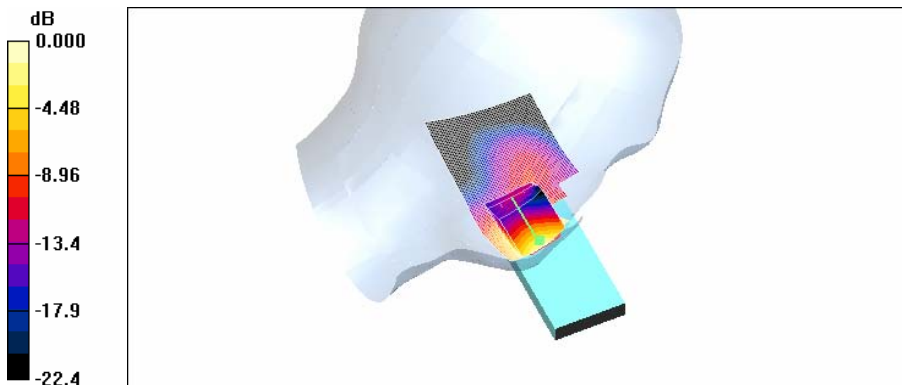

0 dB = 0.758mW/g

Test Laboratory: HCT CO., LTD.
EUT Type: Dual-Band CDMA Phone (CDMA/PCS CDMA)
Liquid Temperature: 21.3 °C
Ambient Temperature: 21.5 °C
Test Date: Jan.15, 2008

DUT: EZ2; Type: Folder; Serial: #1

Communication System: PCS 1900; Frequency: 1851.25 MHz; Duty Cycle: 1:1
Medium parameters used (interpolated): $f = 1851.25$ MHz; $\sigma = 1.34$ mho/m; $\epsilon_r = 40.1$; $\rho = 1000$ kg/m³
Phantom section: Right Section ; Measurement SW: DASY4, V4.6 Build 23; Postprocessing SW: SEMCAD, V1.8 Build 176

DASY4 Configuration:

- Probe: ET3DV6 - SN1609; ConvF(5.36, 5.36, 5.36); Calibrated: 2007-08-30
- Sensor-Surface: 4mm (Mechanical Surface Detection)
- Electronics: DAE3 Sn466; Calibrated: 2007-01-25
- Phantom: 1800/1900 Phantom; Type: SAM

Right touch 25/Area Scan (51x111x1): Measurement grid: dx=15mm, dy=15mm

[Info: Interpolated medium parameters used for SAR evaluation.](#)

Maximum value of SAR (interpolated) = 0.464 mW/g

Right touch 25/Zoom Scan (5x5x7)/Cube 0: Measurement grid: dx=8mm, dy=8mm, dz=5mm

Reference Value = 5.76 V/m; Power Drift = 0.032 dB

Peak SAR (extrapolated) = 0.604 W/kg

SAR(1 g) = 0.435 mW/g; SAR(10 g) = 0.273 mW/g

[Info: Interpolated medium parameters used for SAR evaluation.](#)

Maximum value of SAR (measured) = 0.491 mW/g

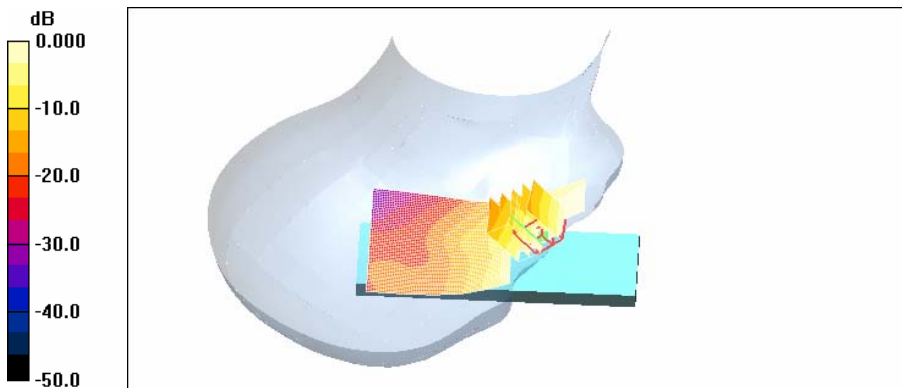

0 dB = 0.491mW/g

Test Laboratory: HCT CO., LTD.
EUT Type: Dual-Band CDMA Phone (CDMA/PCS CDMA)
Liquid Temperature: 21.3 °C
Ambient Temperature: 21.5 °C
Test Date: Jan.15, 2008

DUT: EZ2; Type: Folder; Serial: #1

Communication System: PCS 1900; Frequency: 1880 MHz; Duty Cycle: 1:1
Medium parameters used: $f = 1880$ MHz; $\sigma = 1.37$ mho/m; $\epsilon_r = 40$; $\rho = 1000$ kg/m³
Phantom section: Right Section ; Measurement SW: DASY4, V4.6 Build 23; Postprocessing SW: SEMCAD, V1.8 Build 176

DASY4 Configuration:

- Probe: ET3DV6 - SN1609; ConvF(5.36, 5.36, 5.36); Calibrated: 2007-08-30
- Sensor-Surface: 4mm (Mechanical Surface Detection)
- Electronics: DAE3 Sn466; Calibrated: 2007-01-25
- Phantom: 1800/1900 Phantom; Type: SAM

Right touch 600/Area Scan (51x111x1): Measurement grid: dx=15mm, dy=15mm
Maximum value of SAR (interpolated) = 0.690 mW/g

Right touch 600/Zoom Scan (5x5x7)/Cube 0: Measurement grid: dx=8mm, dy=8mm, dz=5mm
Reference Value = 9.37 V/m; Power Drift = 0.036 dB
Peak SAR (extrapolated) = 0.881 W/kg
SAR(1 g) = 0.635 mW/g; SAR(10 g) = 0.387 mW/g

Maximum value of SAR (measured) = 0.713 mW/g

Right touch 600/Zoom Scan (5x5x7)/Cube 1: Measurement grid: dx=8mm, dy=8mm, dz=5mm
Reference Value = 9.37 V/m; Power Drift = 0.036 dB
Peak SAR (extrapolated) = 0.743 W/kg
SAR(1 g) = 0.466 mW/g; SAR(10 g) = 0.278 mW/g

Maximum value of SAR (measured) = 0.508 mW/g

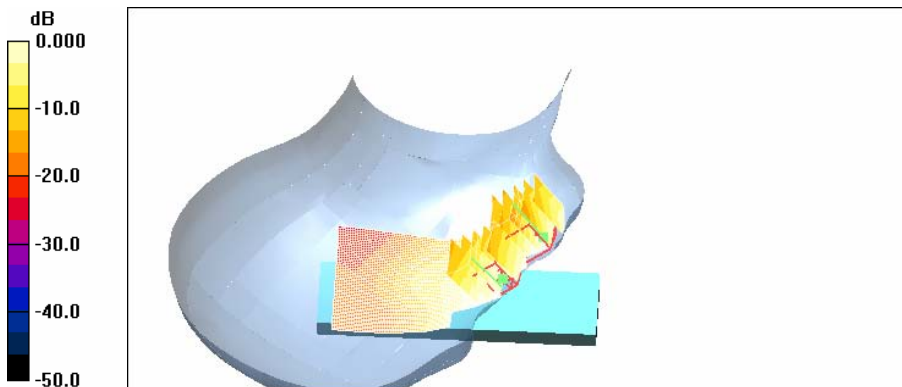

0 dB = 0.508mW/g

Test Laboratory: HCT CO., LTD.
EUT Type: Dual-Band CDMA Phone (CDMA/PCS CDMA)
Liquid Temperature: 21.3 °C
Ambient Temperature: 21.5 °C
Test Date: Jan.15, 2008

DUT: EZ2; Type: Folder; Serial: #1

Communication System: PCS 1900; Frequency: 1908.75 MHz; Duty Cycle: 1:1
Medium parameters used (interpolated): $f = 1908.75$ MHz; $\sigma = 1.4$ mho/m; $\epsilon_r = 40$; $\rho = 1000$ kg/m³
Phantom section: Right Section ; Measurement SW: DASY4, V4.6 Build 23; Postprocessing SW: SEMCAD, V1.8 Build 176

DASY4 Configuration:

- Probe: ET3DV6 - SN1609; ConvF(5.36, 5.36, 5.36); Calibrated: 2007-08-30
- Sensor-Surface: 4mm (Mechanical Surface Detection)
- Electronics: DAE3 Sn466; Calibrated: 2007-01-25
- Phantom: 1800/1900 Phantom; Type: SAM

Right touch 1175/Area Scan (51x111x1): Measurement grid: dx=15mm, dy=15mm

[Info: Interpolated medium parameters used for SAR evaluation.](#)

Maximum value of SAR (interpolated) = 0.328 mW/g

Right touch 1175/Zoom Scan (5x5x7)/Cube 0: Measurement grid: dx=8mm, dy=8mm, dz=5mm

Reference Value = 7.59 V/m; Power Drift = 0.088 dB

Peak SAR (extrapolated) = 0.476 W/kg

SAR(1 g) = 0.298 mW/g; SAR(10 g) = 0.175 mW/g

[Info: Interpolated medium parameters used for SAR evaluation.](#)

Maximum value of SAR (measured) = 0.313 mW/g

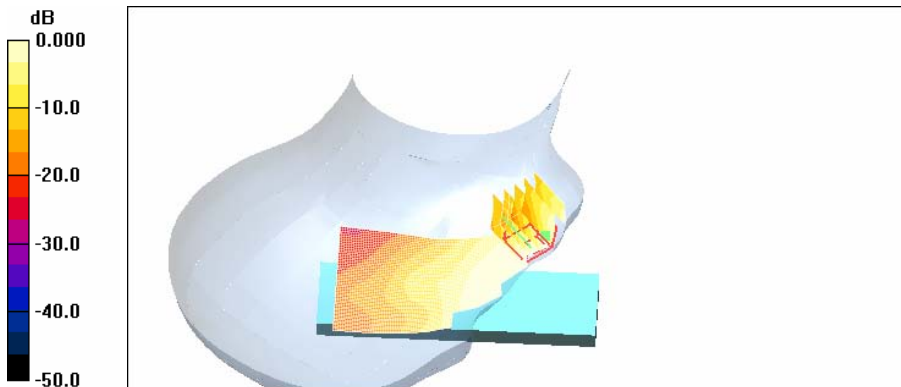

0 dB = 0.313mW/g

Test Laboratory: HCT CO., LTD.
EUT Type: Dual-Band CDMA Phone (CDMA/PCS CDMA)
Liquid Temperature: 21.3 °C
Ambient Temperature: 21.5 °C
Test Date: Jan.15, 2008
Option: Extended battery

DUT: EZ2; Type: Folder; Serial: #1

Communication System: PCS 1900; Frequency: 1880 MHz; Duty Cycle: 1:1
Medium parameters used: $f = 1880$ MHz; $\sigma = 1.37$ mho/m; $\epsilon_r = 40$; $\rho = 1000$ kg/m³
Phantom section: Left Section ; Measurement SW: DASY4, V4.6 Build 23; Postprocessing SW: SEMCAD, V1.8 Build 176

DASY4 Configuration:

- Probe: ET3DV6 - SN1609; ConvF(5.36, 5.36, 5.36); Calibrated: 2007-08-30
- Sensor-Surface: 4mm (Mechanical Surface Detection)
- Electronics: DAE3 Sn466; Calibrated: 2007-01-25
- Phantom: 1800/1900 Phantom; Type: SAM

Left touch 600/Area Scan (51x111x1): Measurement grid: dx=15mm, dy=15mm
Maximum value of SAR (interpolated) = 1.03 mW/g

Left touch 600/Zoom Scan (5x5x7)/Cube 0: Measurement grid: dx=8mm, dy=8mm, dz=5mm
Reference Value = 7.65 V/m; Power Drift = 0.034 dB
Peak SAR (extrapolated) = 1.48 W/kg
SAR(1 g) = 0.913 mW/g; SAR(10 g) = 0.536 mW/g
Maximum value of SAR (measured) = 1.00 mW/g

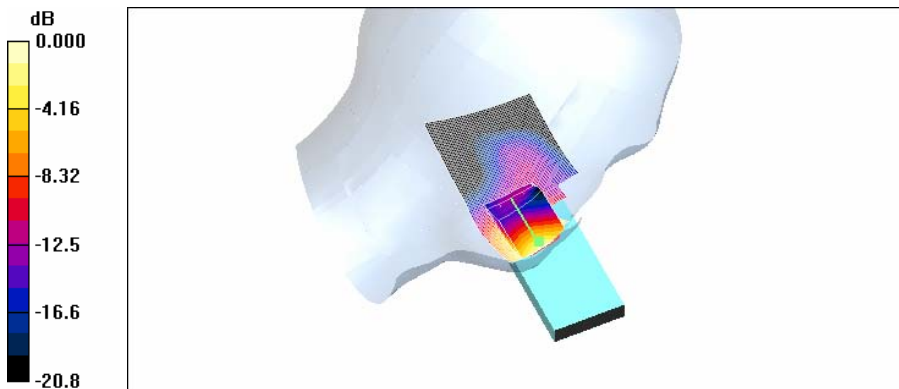

0 dB = 1.00mW/g

Test Laboratory: HCT CO., LTD.
EUT Type: Dual-Band CDMA Phone (CDMA/PCS CDMA)
Liquid Temperature: 21.3 °C
Ambient Temperature: 21.5 °C
Test Date: Jan.15, 2008

DUT: EZ2; Type: Folder; Serial: #1

Communication System: PCS 1900; Frequency: 1880 MHz; Duty Cycle: 1:1
Medium parameters used: $f = 1880$ MHz; $\sigma = 1.37$ mho/m; $\epsilon_r = 40$; $\rho = 1000$ kg/m³
Phantom section: Left Section ; Measurement SW: DASY4, V4.6 Build 23; Postprocessing SW: SEMCAD, V1.8 Build 176

DASY4 Configuration:

- Probe: ET3DV6 - SN1609; ConvF(5.36, 5.36, 5.36); Calibrated: 2007-08-30
- Sensor-Surface: 4mm (Mechanical Surface Detection)
- Electronics: DAE3 Sn466; Calibrated: 2007-01-25
- Phantom: 1800/1900 Phantom; Type: SAM

Left tilt 600/Area Scan (51x111x1): Measurement grid: dx=15mm, dy=15mm
Maximum value of SAR (interpolated) = 0.138 mW/g

Left tilt 600/Zoom Scan (5x5x7)/Cube 0: Measurement grid: dx=8mm, dy=8mm, dz=5mm
Reference Value = 5.50 V/m; Power Drift = 0.027 dB
Peak SAR (extrapolated) = 0.190 W/kg
SAR(1 g) = 0.128 mW/g; SAR(10 g) = 0.081 mW/g
Maximum value of SAR (measured) = 0.139 mW/g

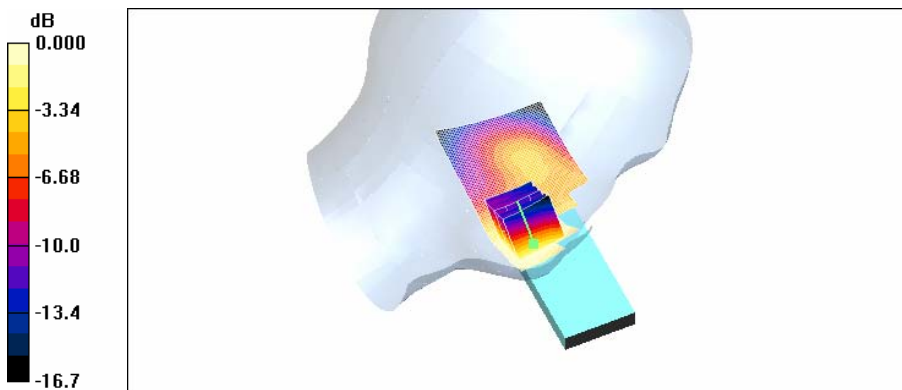

0 dB = 0.139mW/g

Test Laboratory: HCT CO., LTD.
EUT Type: Dual-Band CDMA Phone (CDMA/PCS CDMA)
Liquid Temperature: 21.3 °C
Ambient Temperature: 21.5 °C
Test Date: Jan.15, 2008

DUT: EZ2; Type: Folder; Serial: #1

Communication System: PCS 1900; Frequency: 1880 MHz; Duty Cycle: 1:1
Medium parameters used: $f = 1880$ MHz; $\sigma = 1.37$ mho/m; $\epsilon_r = 40$; $\rho = 1000$ kg/m³
Phantom section: Right Section ; Measurement SW: DASY4, V4.6 Build 23; Postprocessing SW: SEMCAD, V1.8 Build 176

DASY4 Configuration:

- Probe: ET3DV6 - SN1609; ConvF(5.36, 5.36, 5.36); Calibrated: 2007-08-30
- Sensor-Surface: 4mm (Mechanical Surface Detection)
- Electronics: DAE3 Sn466; Calibrated: 2007-01-25
- Phantom: 1800/1900 Phantom; Type: SAM

Right tilt 600/Area Scan (51x111x1): Measurement grid: dx=15mm, dy=15mm
Maximum value of SAR (interpolated) = 0.094 mW/g

Right tilt 600/Zoom Scan (5x5x7)/Cube 0: Measurement grid: dx=8mm, dy=8mm, dz=5mm
Reference Value = 6.83 V/m; Power Drift = -0.130 dB
Peak SAR (extrapolated) = 0.136 W/kg
SAR(1 g) = 0.091 mW/g; SAR(10 g) = 0.060 mW/g

Maximum value of SAR (measured) = 0.096 mW/g

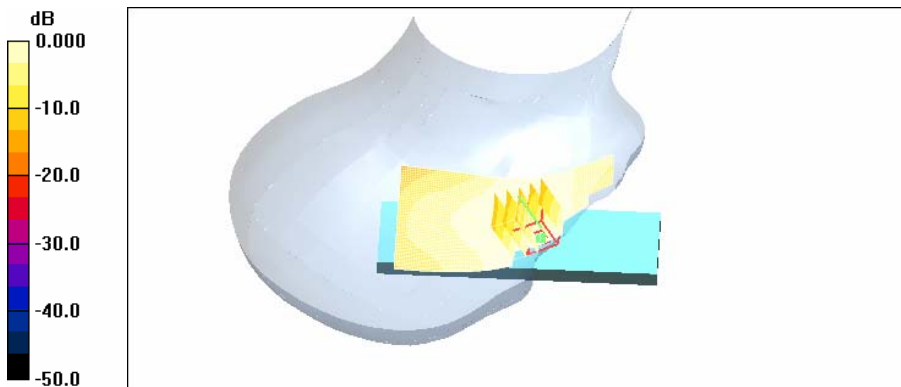

Test Laboratory: HCT CO., LTD.
EUT Type: Dual-Band CDMA Phone (CDMA/PCS CDMA)
Liquid Temperature: 21.5 °C
Ambient Temperature: 21.7 °C
Test Date: Jan.14, 2008

DUT: EZ2 ; Type: Folder BODY; Serial: #1

Communication System: CDMA 835MHz FCC; Frequency: 836.52 MHz; Duty Cycle: 1:1
Medium parameters used (interpolated): $f = 836.52$ MHz; $\sigma = 0.98$ mho/m; $\epsilon_r = 54.8$; $\rho = 1000$ kg/m³
Phantom section: Flat Section ; Measurement SW: DASY4, V4.6 Build 23; Postprocessing SW: SEMCAD, V1.8 Build 176

DASY4 Configuration:

- Probe: ET3DV6 - SN1609; ConvF(6.49, 6.49, 6.49); Calibrated: 2007-08-30
- Sensor-Surface: 4mm (Mechanical Surface Detection)
- Electronics: DAE3 Sn466; Calibrated: 2007-01-25
- Phantom: 835/900 Phamtom ; Type: SAM

CDMA Body 384/Area Scan (41x81x1): Measurement grid: dx=15mm, dy=15mm

[Info: Interpolated medium parameters used for SAR evaluation.](#)

Maximum value of SAR (interpolated) = 0.523 mW/g

CDMA Body 384/Zoom Scan (5x5x7)/Cube 0: Measurement grid: dx=8mm, dy=8mm, dz=5mm

Reference Value = 13.0 V/m; Power Drift = -0.129 dB

Peak SAR (extrapolated) = 0.581 W/kg

SAR(1 g) = 0.447 mW/g; SAR(10 g) = 0.326 mW/g

[Info: Interpolated medium parameters used for SAR evaluation.](#)

Maximum value of SAR (measured) = 0.476 mW/g

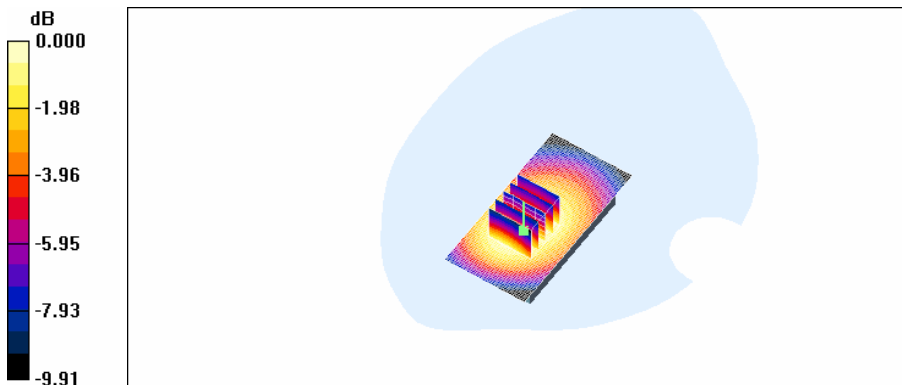

Test Laboratory: HCT CO., LTD.
EUT Type: Dual-Band CDMA Phone (CDMA/PCS CDMA)
Liquid Temperature: 21.5 °C
Ambient Temperature: 21.7 °C
Test Date: Jan.14, 2008
Option: Extended battery

DUT: EZ2 ; Type: Folder BODY; Serial: #1

Communication System: CDMA 835MHz FCC; Frequency: 836.52 MHz; Duty Cycle: 1:1
Medium parameters used (interpolated): $f = 836.52$ MHz; $\sigma = 0.99$ mho/m; $\epsilon_r = 53.4$; $\rho = 1000$ kg/m³
Phantom section: Flat Section ; Measurement SW: DASY4, V4.6 Build 23; Postprocessing SW: SEMCAD, V1.8 Build 176

DASY4 Configuration:

- Probe: ET3DV6 - SN1609; ConvF(6.49, 6.49, 6.49); Calibrated: 2007-08-30
- Sensor-Surface: 4mm (Mechanical Surface Detection)
- Electronics: DAE3 Sn466; Calibrated: 2007-01-25
- Phantom: 835/900 Phantom ; Type: SAM

CDMA Body 384/Area Scan (41x81x1): Measurement grid: dx=15mm, dy=15mm

[Info: Interpolated medium parameters used for SAR evaluation.](#)

Maximum value of SAR (interpolated) = 0.489 mW/g

CDMA Body 384/Zoom Scan (5x5x7)/Cube 0: Measurement grid: dx=8mm, dy=8mm, dz=5mm

Reference Value = 12.4 V/m; Power Drift = -0.050 dB

Peak SAR (extrapolated) = 0.563 W/kg

SAR(1 g) = 0.437 mW/g; SAR(10 g) = 0.321 mW/g

[Info: Interpolated medium parameters used for SAR evaluation.](#)

Maximum value of SAR (measured) = 0.465 mW/g

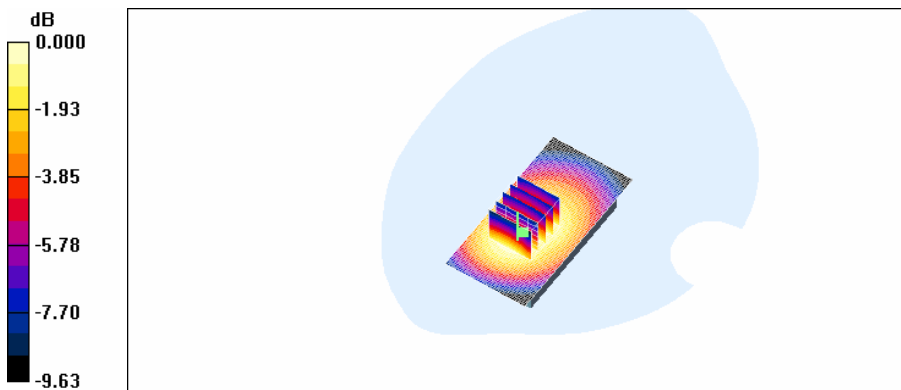

0 dB = 0.465mW/g

Test Laboratory: HCT CO., LTD.
EUT Type: Dual-Band CDMA Phone (CDMA/PCS CDMA)
Liquid Temperature: 21.5 °C
Ambient Temperature: 21.7 °C
Test Date: Jan.14, 2008
Option: Front

DUT: EZ2 ; Type: Folder BODY; Serial: #1

Communication System: CDMA 835MHz FCC; Frequency: 836.52 MHz; Duty Cycle: 1:1
Medium parameters used (interpolated): $f = 836.52$ MHz; $\sigma = 0.99$ mho/m; $\epsilon_r = 53.4$; $\rho = 1000$ kg/m³
Phantom section: Flat Section ; Measurement SW: DASY4, V4.6 Build 23; Postprocessing SW: SEMCAD, V1.8 Build 176

DASY4 Configuration:

- Probe: ET3DV6 - SN1609; ConvF(6.49, 6.49, 6.49); Calibrated: 2007-08-30
- Sensor-Surface: 4mm (Mechanical Surface Detection)
- Electronics: DAE3 Sn466; Calibrated: 2007-01-25
- Phantom: 835/900 Phantom ; Type: SAM

CDMA Body 384/Area Scan (41x81x1): Measurement grid: dx=15mm, dy=15mm

[Info: Interpolated medium parameters used for SAR evaluation.](#)

Maximum value of SAR (interpolated) = 0.271 mW/g

CDMA Body 384/Zoom Scan (5x5x7)/Cube 0: Measurement grid: dx=8mm, dy=8mm, dz=5mm

Reference Value = 9.52 V/m; Power Drift = 0.051 dB

Peak SAR (extrapolated) = 0.308 W/kg

SAR(1 g) = 0.250 mW/g; SAR(10 g) = 0.187 mW/g

[Info: Interpolated medium parameters used for SAR evaluation.](#)

Maximum value of SAR (measured) = 0.266 mW/g

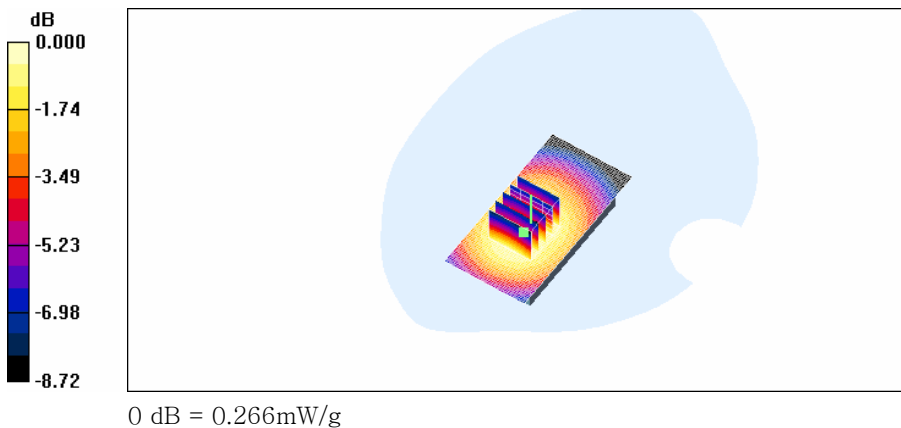

Test Laboratory: HCT CO., LTD.
EUT Type: Dual-Band CDMA Phone (CDMA/PCS CDMA)
Liquid Temperature: 21.3 °C
Ambient Temperature: 21.5 °C
Test Date: Jan.15, 2008

DUT: EZ2; Type: Folder BODY; Serial: #1

Communication System: PCS 1900; Frequency: 1880 MHz; Duty Cycle: 1:1
Medium parameters used: $f = 1880$ MHz; $\sigma = 1.54$ mho/m; $\epsilon_r = 52$; $\rho = 1000$ kg/m³
Phantom section: Flat Section ; Measurement SW: DASY4, V4.6 Build 23; Postprocessing SW: SEMCAD, V1.8 Build 176

DASY4 Configuration:

- Probe: ET3DV6 - SN1609; ConvF(4.74, 4.74, 4.74); Calibrated: 2007-08-30
- Sensor-Surface: 4mm (Mechanical Surface Detection)
- Electronics: DAE3 Sn466; Calibrated: 2007-01-25
- Phantom: 1800/1900 Phantom; Type: SAM

PCS Body 600/Area Scan (51x91x1): Measurement grid: dx=15mm, dy=15mm
Maximum value of SAR (interpolated) = 0.387 mW/g

PCS Body 600/Zoom Scan (5x5x7)/Cube 0: Measurement grid: dx=8mm, dy=8mm, dz=5mm
Reference Value = 7.54 V/m; Power Drift = 0.171 dB
Peak SAR (extrapolated) = 0.566 W/kg
SAR(1 g) = 0.360 mW/g; SAR(10 g) = 0.216 mW/g
Maximum value of SAR (measured) = 0.390 mW/g

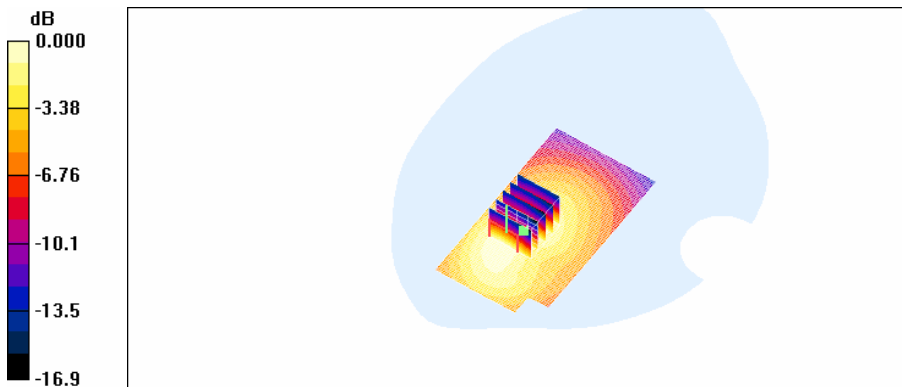

0 dB = 0.390mW/g

Test Laboratory: HCT CO., LTD.
EUT Type: Dual-Band CDMA Phone (CDMA/PCS CDMA)
Liquid Temperature: 21.3 °C
Ambient Temperature: 21.5 °C
Test Date: Jan.15, 2008
Option: Extended battery

DUT: EZ2; Type: Folder BODY; Serial: #1

Communication System: PCS 1900; Frequency: 1880 MHz; Duty Cycle: 1:1
Medium parameters used: $f = 1880$ MHz; $\sigma = 1.54$ mho/m; $\epsilon_r = 52$; $\rho = 1000$ kg/m³
Phantom section: Flat Section ; Measurement SW: DASY4, V4.6 Build 23; Postprocessing SW: SEMCAD, V1.8 Build 176

DASY4 Configuration:

- Probe: ET3DV6 - SN1609; ConvF(4.74, 4.74, 4.74); Calibrated: 2007-08-30
- Sensor-Surface: 4mm (Mechanical Surface Detection)
- Electronics: DAE3 Sn466; Calibrated: 2007-01-25
- Phantom: 1800/1900 Phantom; Type: SAM

PCS Body 600/Area Scan (51x91x1): Measurement grid: dx=15mm, dy=15mm

Maximum value of SAR (interpolated) = 0.338 mW/g

PCS Body 600/Zoom Scan (5x5x7)/Cube 0: Measurement grid: dx=8mm, dy=8mm, dz=5mm

Reference Value = 6.58 V/m; Power Drift = -0.094 dB

Peak SAR (extrapolated) = 0.507 W/kg

SAR(1 g) = 0.326 mW/g; SAR(10 g) = 0.197 mW/g

Maximum value of SAR (measured) = 0.355 mW/g

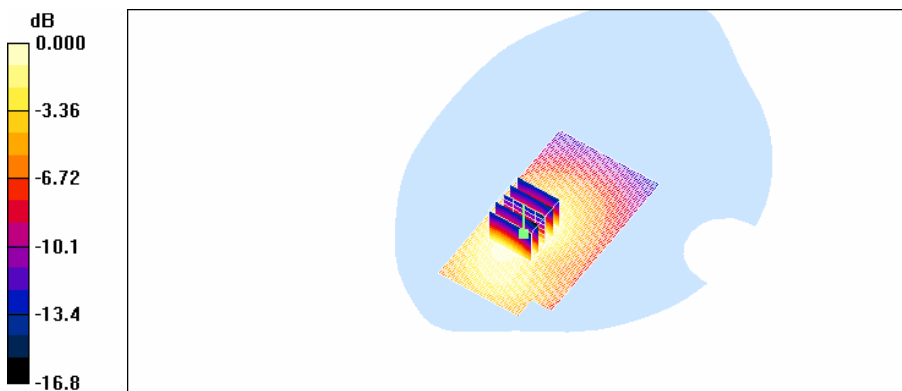

0 dB = 0.355mW/g

Test Laboratory: HCT CO., LTD.
EUT Type: Dual-Band CDMA Phone (CDMA/PCS CDMA)
Liquid Temperature: 21.3 °C
Ambient Temperature: 21.5 °C
Test Date: Jan.15, 2008
Option: Front

DUT: EZ2; Type: Folder BODY; Serial: #1

Communication System: PCS 1900; Frequency: 1880 MHz; Duty Cycle: 1:1
Medium parameters used: $f = 1880$ MHz; $\sigma = 1.54$ mho/m; $\epsilon_r = 52$; $\rho = 1000$ kg/m³
Phantom section: Flat Section ; Measurement SW: DASY4, V4.6 Build 23; Postprocessing SW: SEMCAD, V1.8 Build 176

DASY4 Configuration:

- Probe: ET3DV6 - SN1609; ConvF(4.74, 4.74, 4.74); Calibrated: 2007-08-30
- Sensor-Surface: 4mm (Mechanical Surface Detection)
- Electronics: DAE3 Sn466; Calibrated: 2007-01-25
- Phantom: 1800/1900 Phantom; Type: SAM

PCS Body 600/Area Scan (51x91x1): Measurement grid: dx=15mm, dy=15mm

Maximum value of SAR (interpolated) = 0.290 mW/g

PCS Body 600/Zoom Scan (5x5x7)/Cube 0: Measurement grid: dx=8mm, dy=8mm, dz=5mm

Reference Value = 9.20 V/m; Power Drift = 0.164 dB

Peak SAR (extrapolated) = 0.430 W/kg

SAR(1 g) = 0.288 mW/g; SAR(10 g) = 0.175 mW/g

Maximum value of SAR (measured) = 0.311 mW/g

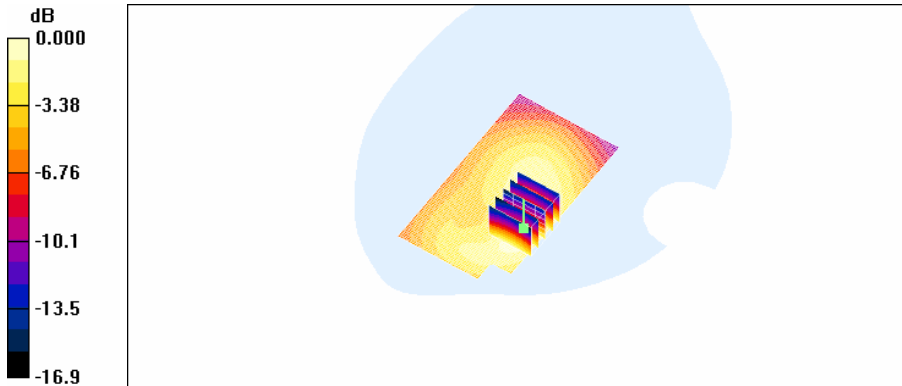

0 dB = 0.311mW/g

Test Laboratory: HCT CO., LTD.
 EUT Type: Dual-Band CDMA Phone (CDMA/PCS CDMA)
 Liquid Temperature: 21.5 °C
 Ambient Temperature: 21.7 °C
 Test Date: Jan.14, 2008

DUT: EZ2; Type: Folder; Serial: #1

Communication System: CDMA 835MHz FCC; Frequency: 836.52 MHz; Duty Cycle: 1:1
 Medium parameters used (interpolated): $f = 836.52 \text{ MHz}$; $\sigma = 0.895 \text{ mho/m}$; $\epsilon_r = 40.8$; $\rho = 1000 \text{ kg/m}^3$
 Phantom section: Left Section ; Measurement SW: DASY4, V4.6 Build 23; Postprocessing SW: SEMCAD, V1.8 Build 176

DASY4 Configuration:

- Probe: ET3DV6 - SN1609; ConvF(6.81, 6.81, 6.81); Calibrated: 2007-08-30
- Sensor-Surface: 4mm (Mechanical Surface Detection)
- Electronics: DAE3 Sn466; Calibrated: 2007-01-25
- Phantom: 835/900 Phantom ; Type: SAM

Left touch 384/Area Scan (51x111x1): Measurement grid: dx=15mm, dy=15mm

[Info: Interpolated medium parameters used for SAR evaluation.](#)

Maximum value of SAR (interpolated) = 1.11 mW/g

Left touch 384/Zoom Scan (5x5x7)/Cube 0: Measurement grid: dx=8mm, dy=8mm, dz=5mm

Reference Value = 22.1 V/m; Power Drift = -0.039 dB

Peak SAR (extrapolated) = 2.79 W/kg

SAR(1 g) = 1.2 mW/g; SAR(10 g) = 0.668 mW/g

[Info: Interpolated medium parameters used for SAR evaluation.](#)

Maximum value of SAR (measured) = 1.48 mW/g

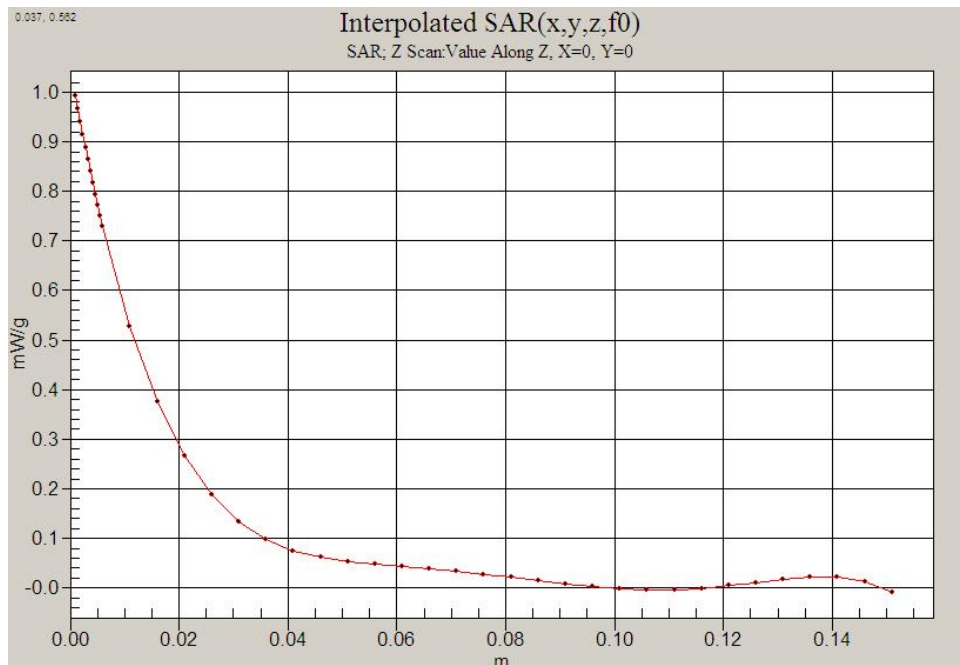

0 dB = 1.48mW/g

Test Laboratory: HCT CO., LTD.
EUT Type: Dual-Band CDMA Phone (CDMA/PCS CDMA)
Liquid Temperature: 21.5 °C
Ambient Temperature: 21.7 °C
Test Date: Jan.14, 2008

DUT: EZ2 ; Type: Folder BODY; Serial: #1

Communication System: CDMA 835MHz FCC; Frequency: 836.52 MHz; Duty Cycle: 1:1
Medium parameters used (interpolated): $f = 836.52$ MHz; $\sigma = 0.98$ mho/m; $\epsilon_r = 54.8$; $\rho = 1000$ kg/m³
Phantom section: Flat Section ; Measurement SW: DASY4, V4.6 Build 23; Postprocessing SW: SEMCAD, V1.8 Build 176

DASY4 Configuration:

- Probe: ET3DV6 - SN1609; ConvF(6.49, 6.49, 6.49); Calibrated: 2007-08-30
- Sensor-Surface: 4mm (Mechanical Surface Detection)
- Electronics: DAE3 Sn466; Calibrated: 2007-01-25
- Phantom: 835/900 Phantom ; Type: SAM

CDMA Body 384/Area Scan (41x81x1): Measurement grid: dx=15mm, dy=15mm

[Info: Interpolated medium parameters used for SAR evaluation.](#)

Maximum value of SAR (interpolated) = 0.523 mW/g

CDMA Body 384/Zoom Scan (5x5x7)/Cube 0: Measurement grid: dx=8mm, dy=8mm, dz=5mm

Reference Value = 13.0 V/m; Power Drift = -0.129 dB

Peak SAR (extrapolated) = 0.581 W/kg

SAR(1 g) = 0.447 mW/g; SAR(10 g) = 0.326 mW/g

[Info: Interpolated medium parameters used for SAR evaluation.](#)

Maximum value of SAR (measured) = 0.476 mW/g

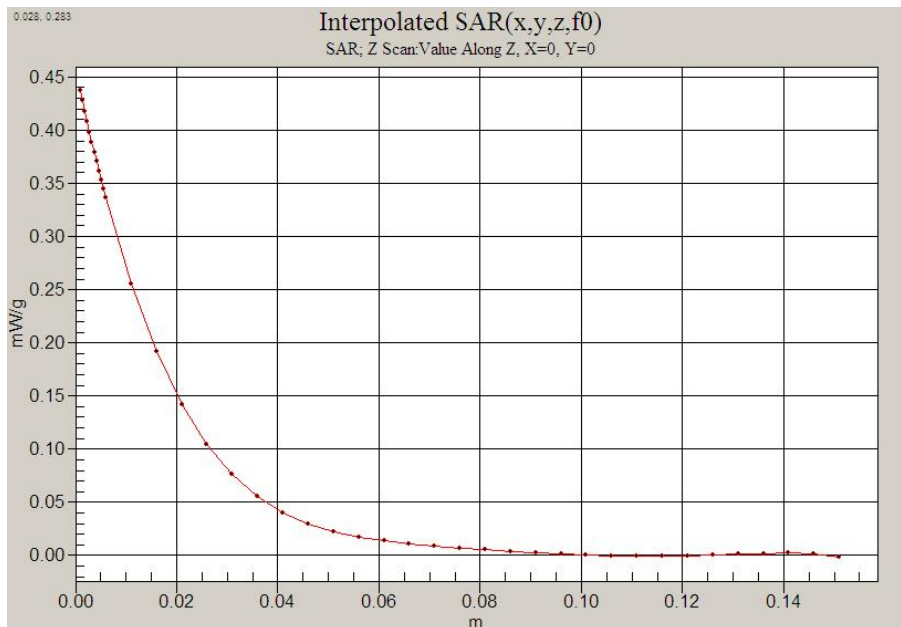

0 dB = 0.476mW/g

Test Laboratory: HCT CO., LTD.
 EUT Type: Dual-Band CDMA Phone (CDMA/PCS CDMA)
 Liquid Temperature: 21.3 °C
 Ambient Temperature: 21.5 °C
 Test Date: Jan.15, 2008

DUT: EZ2; Type: Folder; Serial: #1

Communication System: PCS 1900; Frequency: 1880 MHz; Duty Cycle: 1:1
 Medium parameters used: $f = 1880$ MHz; $\sigma = 1.37$ mho/m; $\epsilon_r = 40$; $\rho = 1000$ kg/m³
 Phantom section: Left Section ; Measurement SW: DASY4, V4.6 Build 23; Postprocessing SW: SEMCAD, V1.8 Build 176

DASY4 Configuration:

- Probe: ET3DV6 - SN1609; ConvF(5.36, 5.36, 5.36); Calibrated: 2007-08-30
- Sensor-Surface: 4mm (Mechanical Surface Detection)
- Electronics: DAE3 Sn466; Calibrated: 2007-01-25
- Phantom: 1800/1900 Phantom; Type: SAM

Left touch 600/Area Scan (51x111x1): Measurement grid: dx=15mm, dy=15mm
 Maximum value of SAR (interpolated) = 1.01 mW/g

Left touch 600/Zoom Scan (5x5x7)/Cube 0: Measurement grid: dx=8mm, dy=8mm, dz=5mm
 Reference Value = 7.71 V/m; Power Drift = 0.093 dB
 Peak SAR (extrapolated) = 1.51 W/kg
SAR(1 g) = 0.972 mW/g; SAR(10 g) = 0.577 mW/g
 Maximum value of SAR (measured) = 1.06 mW/g

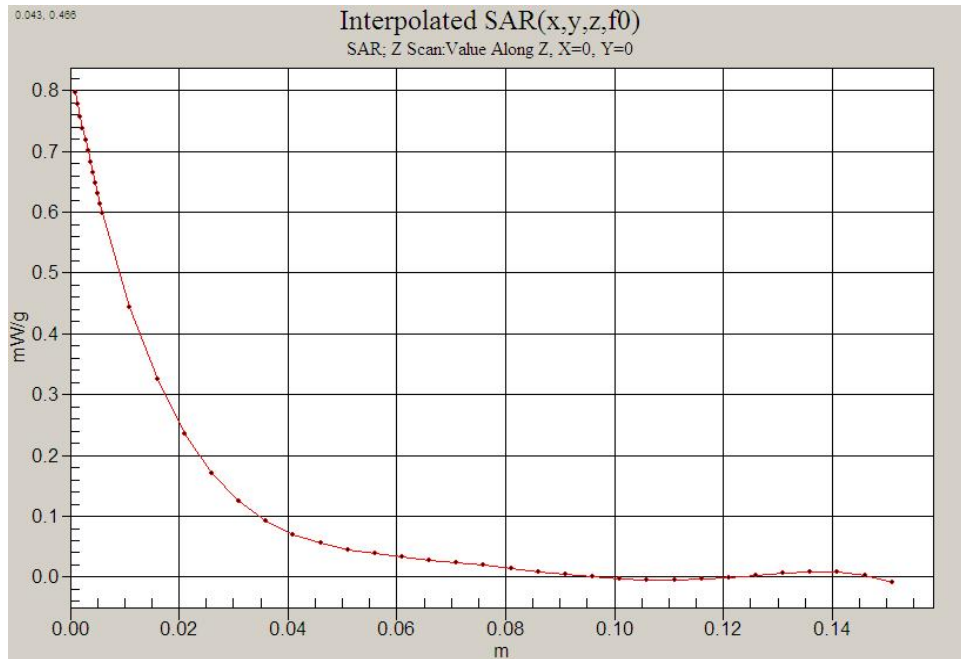

0 dB = 1.06mW/g

Test Laboratory: HCT CO., LTD.
 EUT Type: Dual-Band CDMA Phone (CDMA/PCS CDMA)
 Liquid Temperature: 21.3 °C
 Ambient Temperature: 21.5 °C
 Test Date: Jan.15, 2008

DUT: EZ2; Type: Folder BODY; Serial: #1

Communication System: PCS 1900; Frequency: 1880 MHz; Duty Cycle: 1:1
 Medium parameters used: $f = 1880$ MHz; $\sigma = 1.54$ mho/m; $\epsilon_r = 52$; $\rho = 1000$ kg/m³
 Phantom section: Flat Section ; Measurement SW: DASY4, V4.6 Build 23; Postprocessing SW: SEMCAD, V1.8 Build 176

DASY4 Configuration:

- Probe: ET3DV6 - SN1609; ConvF(4.74, 4.74, 4.74); Calibrated: 2007-08-30
- Sensor-Surface: 4mm (Mechanical Surface Detection)
- Electronics: DAE3 Sn466; Calibrated: 2007-01-25
- Phantom: 1800/1900 Phantom; Type: SAM

PCS Body 600/Area Scan (51x91x1): Measurement grid: dx=15mm, dy=15mm
 Maximum value of SAR (interpolated) = 0.387 mW/g

PCS Body 600/Zoom Scan (5x5x7)/Cube 0: Measurement grid: dx=8mm, dy=8mm, dz=5mm
 Reference Value = 7.54 V/m; Power Drift = 0.171 dB
 Peak SAR (extrapolated) = 0.566 W/kg
SAR(1 g) = 0.360 mW/g; SAR(10 g) = 0.216 mW/g
 Maximum value of SAR (measured) = 0.390 mW/g

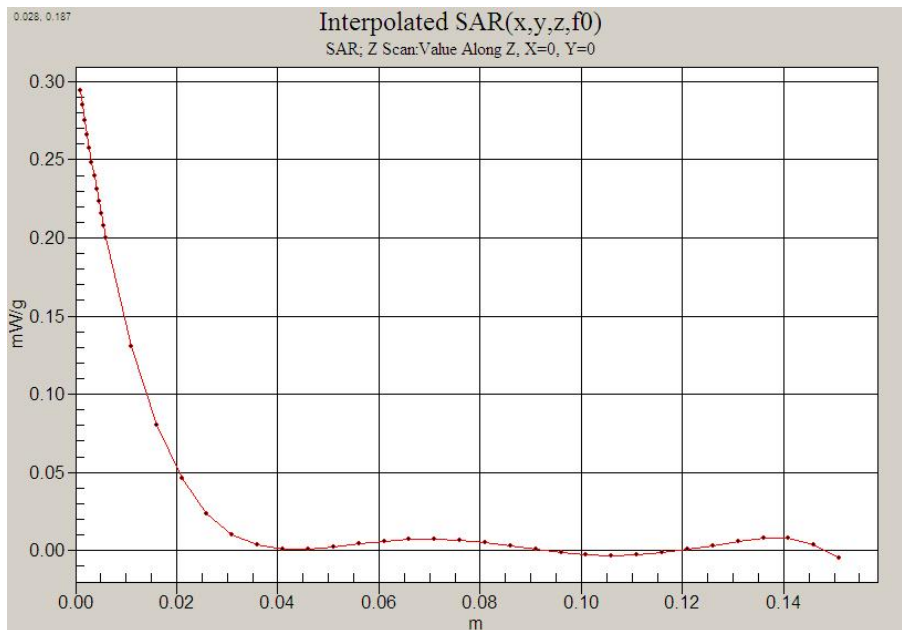

0 dB = 0.390mW/g

Attachment 2. – Dipole Validation Plots

■ Validation Data (835 MHz Head)

Test Laboratory: HCT CO., LTD.

Input Power 1W (30dBm)

Liquid Temp: 21.5

Test Date: Jan.14, 2008

DUT: Dipole 835 MHz; Serial: D835V2 – SN:481

Communication System: CW; Frequency: 835 MHz; Duty Cycle: 1:1

Medium parameters used: $f = 835$ MHz; $\sigma = 0.893$ mho/m; $\epsilon_r = 40.9$; $\rho = 1000$ kg/m³

hantom section: Flat Section ; Measurement SW: DASY4, V4.6 Build 23; Postprocessing SW: SEMCAD, V1.8 Build 176

DASY4 Configuration:

- Probe: ET3DV6 – SN1609; ConvF(6.81, 6.81, 6.81); Calibrated: 2007-08-30

- Sensor-Surface: 4mm (Mechanical Surface Detection)

- Electronics: DAE3 Sn466; Calibrated: 2007-01-25

- Phantom: SAM 835/900 MHz; Type: SAM

Validatoin 835 MHz/Area Scan (61x81x1): Measurement grid: dx=15mm, dy=15mm

Maximum value of SAR (interpolated) = 10.5 mW/g

Validatoin 835 MHz/Zoom Scan (5x5x7)/Cube 0: Measurement grid: dx=8mm, dy=8mm, dz=5mm

Reference Value = 111.4 V/m; Power Drift = -0.047 dB

Peak SAR (extrapolated) = 14.1 W/kg

SAR(1 g) = 9.72 mW/g; SAR(10 g) = 6.43 mW/g

Maximum value of SAR (measured) = 10.5 mW/g

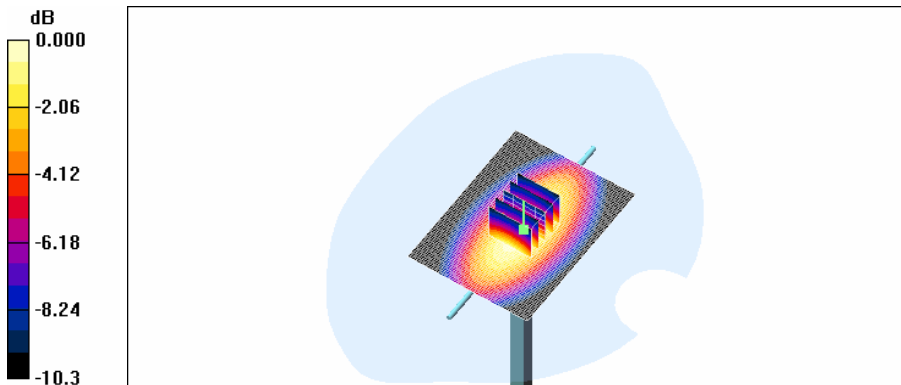

0 dB = 10.5mW/g

■ Validation Data (1900 MHz Head)

Test Laboratory: HCT CO., LTD.

Input Power 1W (30dBm)

Liquid Temp: 21.3

Test Date: Jan.15, 2008

DUT: Dipole 1900 MHz; Serial: D1900V2 - SN:5d032Communication System: CW; Frequency: 1900 MHz; Duty Cycle: 1:1
Medium parameters used: $f = 1900$ MHz; $\sigma = 1.39$ mho/m; $\epsilon_r = 40$; $\rho = 1000$ kg/m³

Phantom section: Flat Section ; Measurement SW: DASY4, V4.6 Build 23; Postprocessing SW: SEMCAD, V1.8 Build 176

DASY4 Configuration:

- Probe: ET3DV6 - SN1609; ConvF(5.36, 5.36, 5.36); Calibrated: 2007-08-30
- Sensor-Surface: 4mm (Mechanical Surface Detection)
- Electronics: DAE3 Sn466; Calibrated: 2007-01-25
- Phantom: SAM 1800/1900 MHz; Type: SAM

Validation 1900MHz/Area Scan (61x61x1): Measurement grid: dx=15mm, dy=15mm
Maximum value of SAR (interpolated) = 46.1 mW/g**Validation 1900MHz/Zoom Scan (5x5x7)/Cube 0:** Measurement grid: dx=8mm, dy=8mm, dz=5mm
Reference Value = 185.2 V/m; Power Drift = -0.003 dB
Peak SAR (extrapolated) = 64.3 W/kg
SAR(1 g) = 37.6 mW/g; SAR(10 g) = 20 mW/g

Maximum value of SAR (measured) = 41.9 mW/g

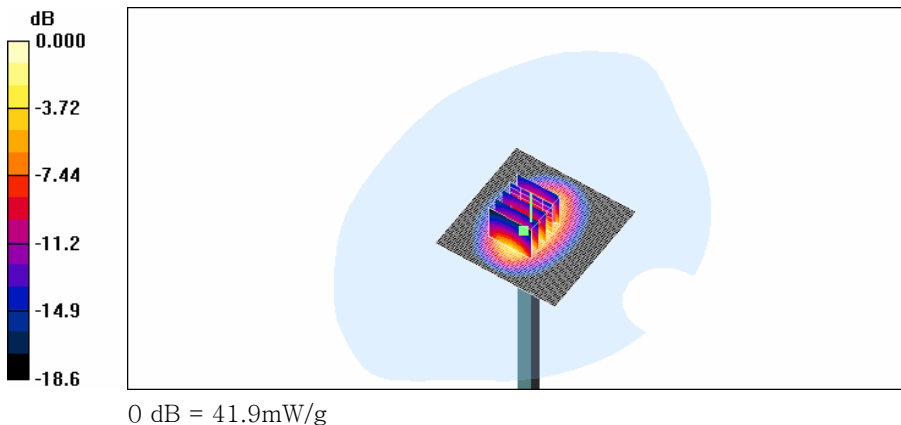

■ Dielectric Parameter (835 MHz Head)

Title EZ2
SubTitle CDMA835(Head)
Test Date Jan.14, 2008

Frequency	e'	e''
800000000	40.7730	19.1978
805000000	40.7675	19.2823
810000000	40.8386	19.3077
815000000	40.8649	19.2856
820000000	40.8857	19.3021
825000000	40.8874	19.2862
830000000	40.8525	19.2698
835000000	40.8533	19.2280
840000000	40.8394	19.2270
845000000	40.8183	19.1604
850000000	40.7111	19.1547
855000000	40.6244	19.1436
860000000	40.4364	19.0590
865000000	40.3257	19.0255
870000000	40.1649	18.9714
875000000	40.0159	18.9705
880000000	39.8588	18.9173
885000000	39.7075	18.8785
890000000	39.6097	18.9000
895000000	39.4806	18.8416
900000000	39.3868	18.8675

■ Dielectric Parameter (835 MHz Body)

Title EZ2
SubTitle CDMA835(Body)
Test Date Jan.14, 2008

Frequency	e'	e''
800000000	53.8213	21.3865
805000000	53.7419	21.4011
810000000	53.6804	21.3981
815000000	53.6537	21.3943
820000000	53.6197	21.3204
825000000	53.5189	21.3378
830000000	53.5272	21.2995
835000000	53.4446	21.2832
840000000	53.3828	21.2597
845000000	53.4001	21.2404
850000000	53.3471	21.2359
855000000	53.2966	21.1765
860000000	53.2812	21.1801
865000000	53.2276	21.1656
870000000	53.1726	21.0877
875000000	53.1747	21.1168
880000000	53.1157	21.0943
885000000	53.0326	21.0339
890000000	52.9958	21.0091
895000000	52.9696	20.9962
900000000	52.8932	21.0132

■ Dielectric Parameter (1900 MHz Head)

Title EZ2
SubTitle PCS1900(Head)
Test Date Jan.15, 2008

Frequency	e'	e''
1800000000	40.6136	12.8470
1810000000	40.5542	12.8462
1820000000	40.4624	12.8934
1830000000	40.3485	12.9125
1840000000	40.2234	12.9878
1850000000	40.1254	12.9981
1860000000	40.0467	12.9938
1870000000	40.0251	13.0675
1880000000	40.0403	13.0844
1890000000	40.0283	13.1455
1900000000	40.0321	13.1691
1910000000	40.0152	13.1912
1920000000	39.9736	13.2057
1930000000	39.8825	13.2559
1940000000	39.7765	13.2542
1950000000	39.6683	13.2784
1960000000	39.5554	13.2975
1970000000	39.4723	13.3416
1980000000	39.4302	13.4054
1990000000	39.4348	13.4497
2000000000	39.4396	13.4966

■ Dielectric Parameter (1900 MHz Body)

Title EZ2
SubTitle PCS1900(Body)
Test Date Jan.15, 2008

Frequency	e'	e''
1850000000	52.0804	14.6195
1855000000	52.0871	14.6505
1860000000	52.0345	14.6829
1865000000	52.0602	14.6685
1870000000	52.0252	14.7074
1875000000	52.0280	14.7273
1880000000	52.0237	14.7428
1885000000	52.0086	14.7536
1890000000	51.9846	14.7579
1895000000	51.9765	14.7876
1900000000	51.9332	14.7734
1905000000	51.9840	14.8116
1910000000	51.9586	14.8284
1915000000	51.9401	14.8244
1920000000	51.9099	14.8349
1925000000	51.8877	14.8418
1930000000	51.8919	14.8535
1935000000	51.8836	14.8983
1940000000	51.8686	14.8881
1945000000	51.8844	14.9071
1950000000	51.8291	14.9342

Attachment 3. – Probe Calibration Data

**Calibration Laboratory of
Schmid & Partner
Engineering AG**
Zeughausstrasse 43, 8004 Zurich, Switzerland



S Schweizerischer Kalibrierdienst
C Service suisse d'étalonnage
S Servizio svizzero di taratura
S Swiss Calibration Service

Accredited by the Swiss Federal Office of Metrology and Accreditation
The Swiss Accreditation Service is one of the signatories to the EA
Multilateral Agreement for the recognition of calibration certificates

Accreditation No.: **SCS 108**

Client: **H-CT (Dymstec)**

Certificate No: **ET3-1609_Aug07**

CALIBRATION CERTIFICATE

Object: **ET3DV6 - SN:1609**

Calibration procedure(s): **QA CAL-01.v6 and QA CAL-12.v5
Calibration procedure for dosimetric E-field probes**

Calibration date: **August 30, 2007**

Condition of the calibrated item: **In Tolerance**

This calibration certificate documents the traceability to national standards, which realize the physical units of measurements (SI).
The measurements and the uncertainties with confidence probability are given on the following pages and are part of the certificate.

All calibrations have been conducted in the closed laboratory facility: environment temperature (22 ± 3)°C and humidity < 70%.

Calibration Equipment used (M&TE critical for calibration)

Primary Standards	ID #	Cal Date (Calibrated by, Certificate No.)	Scheduled Calibration
Power meter E4419B	GB41293874	29-Mar-07 (METAS, No. 217-00670)	Mar-08
Power sensor E4412A	MY41495277	29-Mar-07 (METAS, No. 217-00670)	Mar-08
Power sensor E4412A	MY41498087	29-Mar-07 (METAS, No. 217-00670)	Mar-08
Reference 3 dB Attenuator	SN: S5054 (3c)	8-Aug-07 (METAS, No. 217-00719)	Aug-08
Reference 20 dB Attenuator	SN: S5086 (20b)	29-Mar-07 (METAS, No. 217-00671)	Mar-08
Reference 30 dB Attenuator	SN: S5129 (30b)	8-Aug-07 (METAS, No. 217-00720)	Aug-08
Reference Probe ES3DV2	SN: 3013	4-Jan-07 (SPEAG, No. ES3-3013_Jan07)	Jan-08
DAE4	SN: 654	20-Apr-07 (SPEAG, No. DAE4-654_Apr07)	Apr-08

Secondary Standards	ID #	Check Date (in house)	Scheduled Check
RF generator HP 8648C	US3642U01700	4-Aug-99 (SPEAG, in house check Nov-05)	In house check: Nov-07
Network Analyzer HP 8753E	US37390585	18-Oct-01 (SPEAG, in house check Oct-06)	In house check: Oct-07

	Name	Function	Signature
Calibrated by:	Katja Pokovic	Technical Manager	
Approved by:	Niels Kuster	Quality Manager	

Issued: August 30, 2007

This calibration certificate shall not be reproduced except in full without written approval of the laboratory.

**Calibration Laboratory of
Schmid & Partner
Engineering AG**
Zeughausstrasse 43, 8904 Zurich, Switzerland



S Schweizerischer Kalibriendienst
C Service suisse d'étalonnage
S Servizio svizzero di taratura
S Swiss Calibration Service

Accredited by the Swiss Federal Office of Metrology and Accreditation
The Swiss Accreditation Service is one of the signatories to the EA
Multilateral Agreement for the recognition of calibration certificates

Accreditation No.: **SCS 108**

Glossary:

TSL	tissue simulating liquid
NORM _{x,y,z}	sensitivity in free space
ConF	sensitivity in TSL / NORM _{x,y,z}
DCP	diode compression point
Polarization ϕ	ϕ rotation around probe axis
Polarization ϑ	ϑ rotation around an axis that is in the plane normal to probe axis (at measurement center), i.e., $\vartheta = 0$ is normal to probe axis

Calibration is Performed According to the Following Standards:

- a) IEEE Std 1528-2003, "IEEE Recommended Practice for Determining the Peak Spatial-Averaged Specific Absorption Rate (SAR) in the Human Head from Wireless Communications Devices: Measurement Techniques", December 2003
- b) IEC 62209-1, "Procedure to measure the Specific Absorption Rate (SAR) for hand-held devices used in close proximity to the ear (frequency range of 300 MHz to 3 GHz)", February 2005

Methods Applied and Interpretation of Parameters:

- **NORM_{x,y,z}**: Assessed for E-field polarization $\vartheta = 0$ ($f \leq 900$ MHz in TEM-cell; $f > 1800$ MHz: R22 waveguide). NORM_{x,y,z} are only intermediate values, i.e., the uncertainties of NORM_{x,y,z} does not effect the E²-field uncertainty inside TSL (see below *ConvF*).
- **NORM(f)_{x,y,z}** = NORM_{x,y,z} * *frequency_response* (see Frequency Response Chart). This linearization is implemented in DASY4 software versions later than 4.2. The uncertainty of the frequency response is included in the stated uncertainty of *ConvF*.
- **DCP_{x,y,z}**: DCP are numerical linearization parameters assessed based on the data of power sweep (no uncertainty required). DCP does not depend on frequency nor media.
- **ConvF and Boundary Effect Parameters**: Assessed in flat phantom using E-field (or Temperature Transfer Standard for $f \leq 800$ MHz) and inside waveguide using analytical field distributions based on power measurements for $f > 800$ MHz. The same setups are used for assessment of the parameters applied for boundary compensation (alpha, depth) of which typical uncertainty values are given. These parameters are used in DASY4 software to improve probe accuracy close to the boundary. The sensitivity in TSL corresponds to NORM_{x,y,z} * *ConvF* whereby the uncertainty corresponds to that given for *ConvF*. A frequency dependent *ConvF* is used in DASY version 4.4 and higher which allows extending the validity from ± 50 MHz to ± 100 MHz.
- **Spherical isotropy (3D deviation from isotropy)**: in a field of low gradients realized using a flat phantom exposed by a patch antenna.
- **Sensor Offset**: The sensor offset corresponds to the offset of virtual measurement center from the probe tip (on probe axis). No tolerance required.

ET3DV6 SN:1609

August 30, 2007

Probe ET3DV6

SN:1609

Manufactured:	July 21, 2001
Last calibrated:	March 23, 2006
Recalibrated:	August 30, 2007

Calibrated for DASYS Systems

(Note: non-compatible with DASYS2 system!)

ET3DV6 SN:1609

August 30, 2007

DASY - Parameters of Probe: ET3DV6 SN:1609

Sensitivity in Free Space ^A			Diode Compression ^B	
NormX	1.94 ± 10.1%	μV/(V/m) ²	DCP X	95 mV
NormY	1.78 ± 10.1%	μV/(V/m) ²	DCP Y	95 mV
NormZ	1.79 ± 10.1%	μV/(V/m) ²	DCP Z	97 mV

Sensitivity in Tissue Simulating Liquid (Conversion Factors)

Please see Page 8.

Boundary Effect

TSL	900 MHz	Typical SAR gradient: 5 % per mm		
	Sensor Center to Phantom Surface Distance		3.7 mm	4.7 mm
	SAR _{be} [%] Without Correction Algorithm		5.3	2.1
	SAR _{be} [%] With Correction Algorithm		0.2	0.2
TSL	1810 MHz	Typical SAR gradient: 10 % per mm		
	Sensor Center to Phantom Surface Distance		3.7 mm	4.7 mm
	SAR _{be} [%] Without Correction Algorithm		13.6	9.0
	SAR _{be} [%] With Correction Algorithm		0.2	0.0

Sensor Offset

Probe Tip to Sensor Center **2.7 mm**

The reported uncertainty of measurement is stated as the standard uncertainty of measurement multiplied by the coverage factor k=2, which for a normal distribution corresponds to a coverage probability of approximately 95%.

^A The uncertainties of NormX,Y,Z do not affect the E²-field uncertainty inside TSL (see Page 8).

^B Numerical linearization parameter: uncertainty not required.

ET3DV6 SN:1609

August 30, 2007

Frequency Response of E-Field

(TEM-Cell:ifi110 EXX, Waveguide: R22)

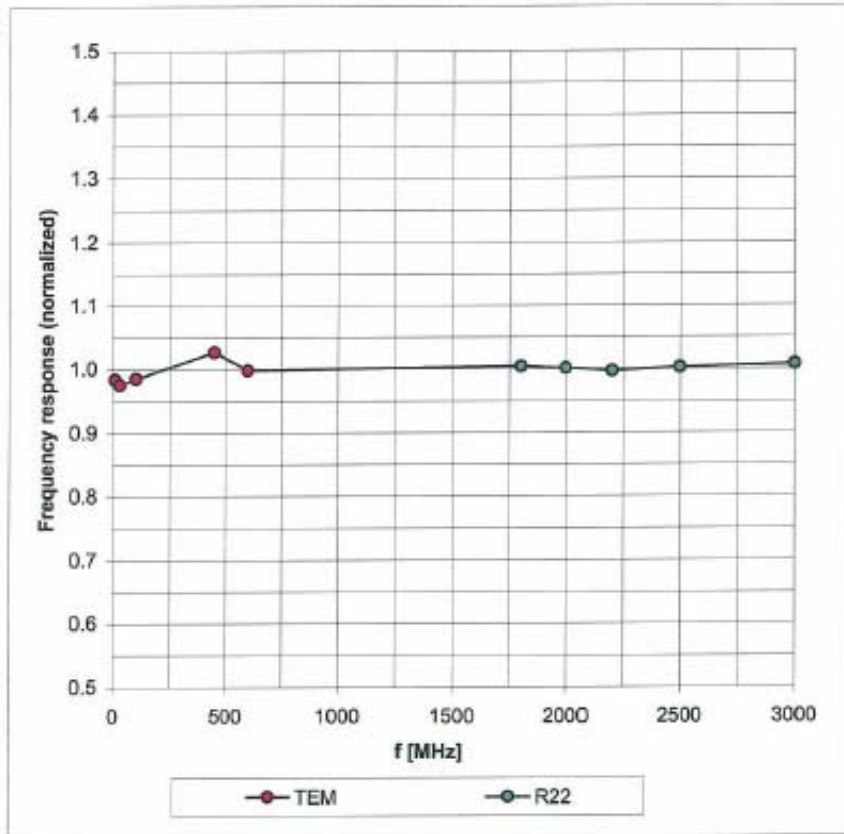

Uncertainty of Frequency Response of E-field: $\pm 6.3\%$ (k=2)

ET3DV6 SN:1609

August 30, 2007

Receiving Pattern (ϕ), $\theta = 0^\circ$

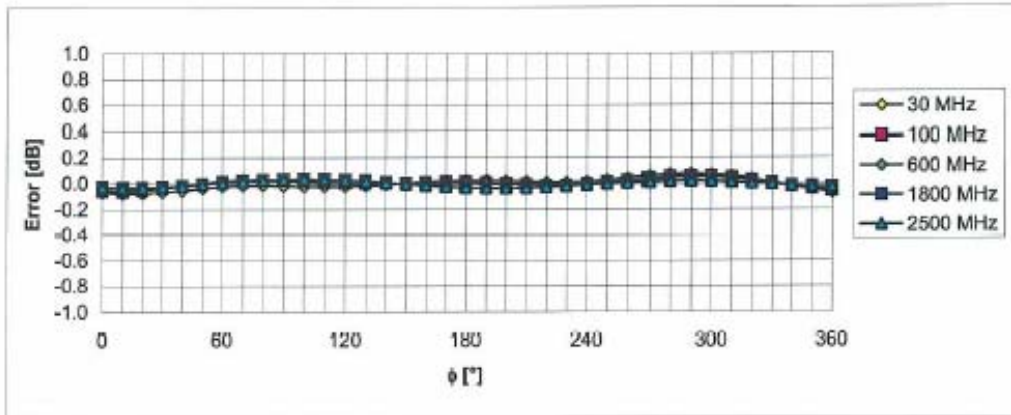
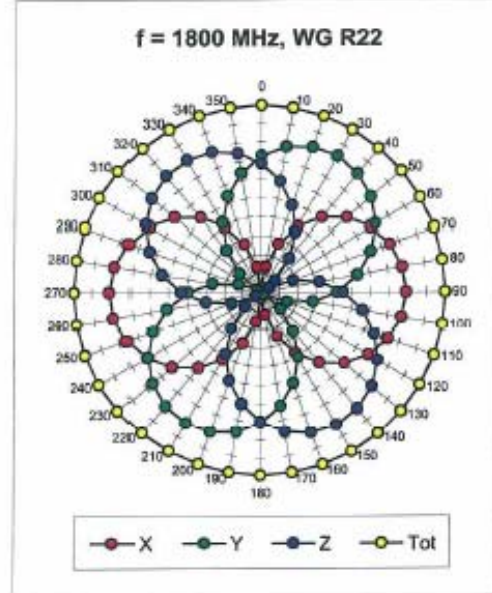
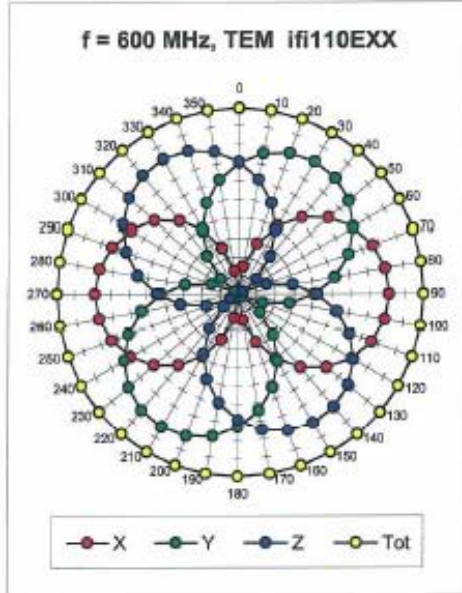

Uncertainty of Axial Isotropy Assessment: $\pm 0.5\%$ (k=2)

ET3DV6 SN:1609

August 30, 2007

Dynamic Range $f(\text{SAR}_{\text{head}})$
(Waveguide R22, $f = 1800 \text{ MHz}$)

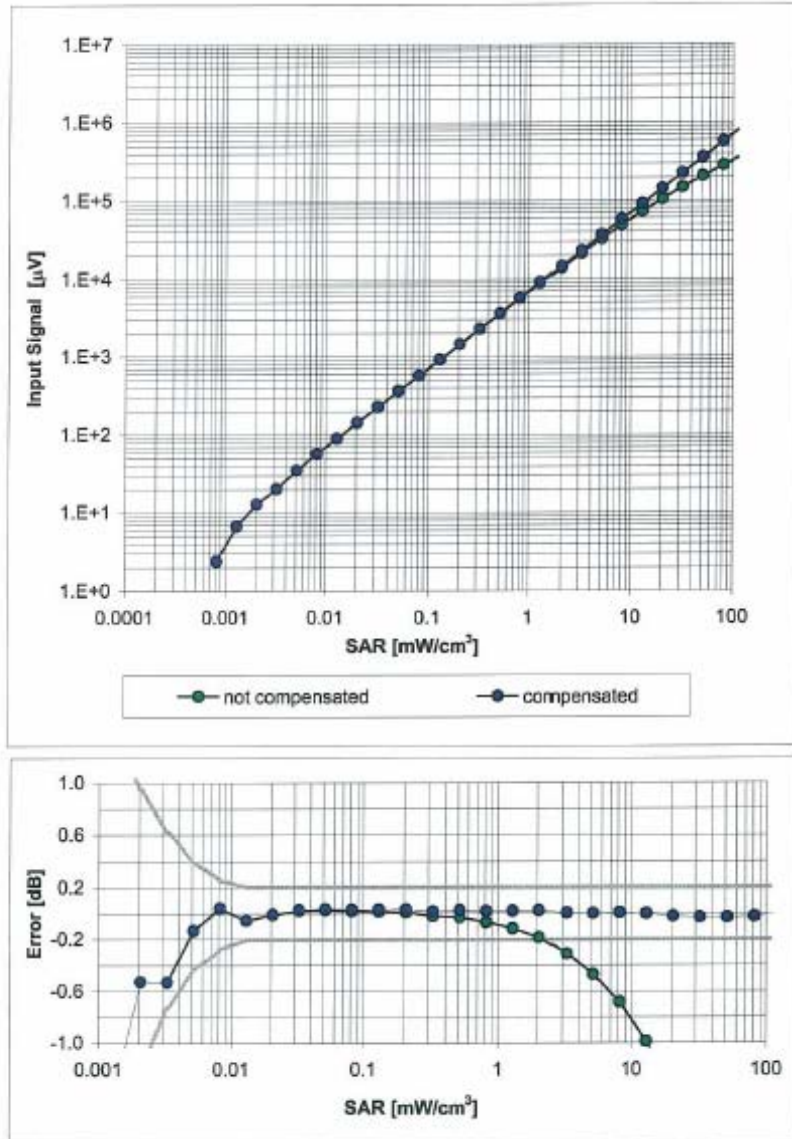

Uncertainty of Linearity Assessment: $\pm 0.6\%$ ($k=2$)

ET3DV6 SN:1609

August 30, 2007

Conversion Factor Assessment

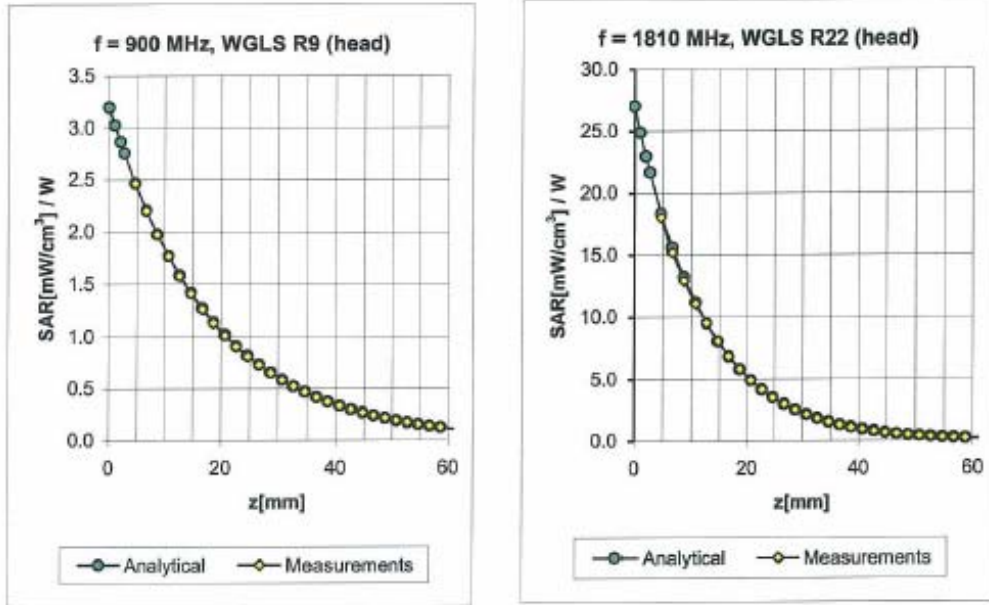

f [MHz]	Validity [MHz] ^c	TSL	Permittivity	Conductivity	Alpha	Depth	ConvF Uncertainty
450	± 50 / ± 100	Head	43.5 ± 5%	0.87 ± 5%	0.37	1.85	7.25 ± 13.3% (k=2)
900	± 50 / ± 100	Head	41.5 ± 5%	0.97 ± 5%	0.36	2.42	6.81 ± 11.0% (k=2)
1810	± 50 / ± 100	Head	40.0 ± 5%	1.40 ± 5%	0.52	2.66	5.36 ± 11.0% (k=2)
1950	± 50 / ± 100	Head	40.0 ± 5%	1.40 ± 5%	0.60	2.50	5.12 ± 11.0% (k=2)
2450	± 50 / ± 100	Head	39.2 ± 5%	1.80 ± 5%	0.69	1.89	4.78 ± 11.8% (k=2)
450	± 50 / ± 100	Body	56.7 ± 5%	0.94 ± 5%	0.31	1.90	7.76 ± 13.3% (k=2)
835	± 50 / ± 100	Body	55.2 ± 5%	0.97 ± 5%	0.35	2.55	6.49 ± 11.0% (k=2)
1900	± 50 / ± 100	Body	53.3 ± 5%	1.52 ± 5%	0.71	2.44	4.74 ± 11.0% (k=2)
2450	± 50 / ± 100	Body	52.7 ± 5%	1.95 ± 5%	0.58	2.37	4.17 ± 11.8% (k=2)

^c The validity of ± 100 MHz only applies for DASY v4.4 and higher (see Page 2). The uncertainty is the RSS of the ConvF uncertainty at calibration frequency and the uncertainty for the indicated frequency band.

ET3DV6 SN:1609

August 30, 2007

Deviation from Isotropy in HSL

Error (ϕ , θ), $f = 900$ MHz

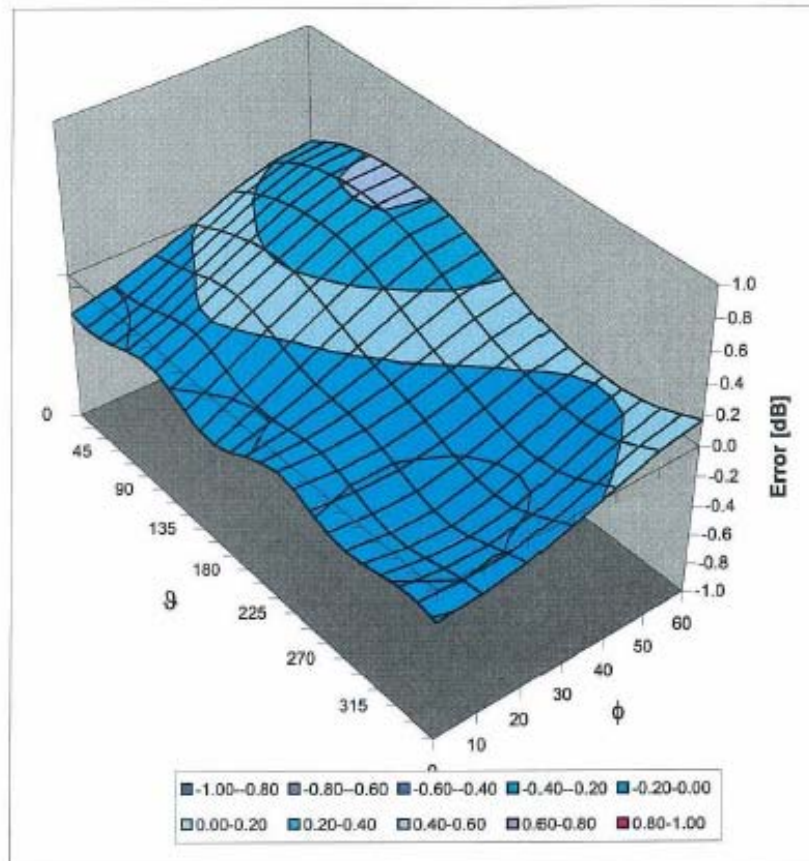

Uncertainty of Spherical Isotropy Assessment: $\pm 2.6\%$ ($k=2$)

Attachment 4. – Dipole Calibration Data

**Calibration Laboratory of
Schmid & Partner
Engineering AG**
Zeughausstrasse 43, 8004 Zurich, Switzerland



S Schweizerischer Kalibrierdienst
C Service suisse d'étalonnage
S Servizio svizzero di taratura
S Swiss Calibration Service

Accredited by the Swiss Federal Office of Metrology and Accreditation
The Swiss Accreditation Service is one of the signatories to the EA
Multilateral Agreement for the recognition of calibration certificates:

Accreditation No.: **SCS 108**

Client **KTL (Dymstec)**

Certificate No: **D835V2-481_May07**

CALIBRATION CERTIFICATE

Object **D835V2 - SN: 481**

Calibration procedure(s) **QA CAL-05.v6
Calibration procedure for dipole validation kits**

Calibration date: **May 24, 2007**

Condition of the calibrated item **In Tolerance**

This calibration certificate documents the traceability to national standards, which realize the physical units of measurements (SI).
The measurements and the uncertainties with confidence probability are given on the following pages and are part of the certificate.

All calibrations have been conducted in the closed laboratory facility: environment temperature (22 ± 3)°C and humidity < 70%.

Calibration Equipment used (M&TE critical for calibration)

Primary Standards	ID #	Cal Date (Calibrated by, Certificate No.)	Scheduled Calibration
Power meter EPM-442A	GB37480704	03-Oct-06 (METAS, No. 217-00608)	Oct-07
Power sensor HP 8481A	US37292783	03-Oct-06 (METAS, No. 217-00608)	Oct-07
Reference 20 dB Attenuator	SN: 5086 (20g)	10-Aug-06 (METAS, No 217-00591)	Aug-07
Reference 10 dB Attenuator	SN: 5047.2 (10r)	10-Aug-06 (METAS, No 217-00591)	Aug-07
Reference Probe ET3DV6 (HF)	SN 1507	19-Oct-06 (SPEAG, No. ET3-1507_Oct06)	Oct-07
DAE4	SN 601	30-Jan-07 (SPEAG, No. DAE4-601_Jan07)	Jan-08
Secondary Standards	ID #	Check Date (in house)	Scheduled Check
Power sensor HP 8481A	MY41092317	18-Oct-02 (SPEAG, in house check Oct-05)	In house check: Oct-07
RF generator Agilent E4421B	MY41000675	11-May-05 (SPEAG, in house check Nov-05)	In house check: Nov-07
Network Analyzer HP 8753E	US37390585 S4206	18-Oct-01 (SPEAG, in house check Oct-06)	In house check: Oct-07

Calibrated by: **Claudio Leubler** (Name), **Laboratory Technician** (Function), *[Signature]* (Signature)

Approved by: **Katja Pokovic** (Name), **Technical Manager** (Function), *[Signature]* (Signature)

Issued: May 30, 2007

This calibration certificate shall not be reproduced except in full without written approval of the laboratory.

Calibration Laboratory of
Schmid & Partner
Engineering AG
Zeughausstrasse 43, 8004 Zurich, Switzerland



S Schweizerischer Kalibrierdienst
C Service suisse d'étalonnage
S Servizio svizzero di taratura
S Swiss Calibration Service

Accredited by the Swiss Federal Office of Metrology and Accreditation
The Swiss Accreditation Service is one of the signatories to the EA
Multilateral Agreement for the recognition of calibration certificates

Accreditation No.: SCS 108

Glossary:

TSL tissue simulating liquid
ConvF sensitivity in TSL / NORM x,y,z
N/A not applicable or not measured

Calibration is Performed According to the Following Standards:

- a) IEEE Std 1528-2003, "IEEE Recommended Practice for Determining the Peak Spatial-Averaged Specific Absorption Rate (SAR) in the Human Head from Wireless Communications Devices: Measurement Techniques", December 2003
- b) IEC 62209-1, "Procedure to measure the Specific Absorption Rate (SAR) for hand-held devices used in close proximity to the ear (frequency range of 300 MHz to 3 GHz)", February 2005
- c) Federal Communications Commission Office of Engineering & Technology (FCC OET), "Evaluating Compliance with FCC Guidelines for Human Exposure to Radiofrequency Electromagnetic Fields; Additional Information for Evaluating Compliance of Mobile and Portable Devices with FCC Limits for Human Exposure to Radiofrequency Emissions", Supplement C (Edition 01-01) to Bulletin 65

Additional Documentation:

- d) DASY4 System Handbook

Methods Applied and Interpretation of Parameters:

- *Measurement Conditions:* Further details are available from the Validation Report at the end of the certificate. All figures stated in the certificate are valid at the frequency indicated.
- *Antenna Parameters with TSL:* The dipole is mounted with the spacer to position its feed point exactly below the center marking of the flat phantom section, with the arms oriented parallel to the body axis.
- *Feed Point Impedance and Return Loss:* These parameters are measured with the dipole positioned under the liquid filled phantom. The impedance stated is transformed from the measurement at the SMA connector to the feed point. The Return Loss ensures low reflected power. No uncertainty required.
- *Electrical Delay:* One-way delay between the SMA connector and the antenna feed point. No uncertainty required.
- *SAR measured:* SAR measured at the stated antenna input power.
- *SAR normalized:* SAR as measured, normalized to an input power of 1 W at the antenna connector.
- *SAR for nominal TSL parameters:* The measured TSL parameters are used to calculate the nominal SAR result.

Measurement Conditions

DASY system configuration, as far as not given on page 1.

DASY Version	DASY4	V4.7
Extrapolation	Advanced Extrapolation	
Phantom	Modular Flat Phantom V4.9	
Distance Dipole Center - TSL	15 mm	with Spacer
Zoom Scan Resolution	dx, dy, dz = 5 mm	
Frequency	835 MHz ± 1 MHz	

Head TSL parameters

The following parameters and calculations were applied.

	Temperature	Permittivity	Conductivity
Nominal Head TSL parameters	22.0 °C	41.5	0.90 mho/m
Measured Head TSL parameters	(22.0 ± 0.2) °C	41.6 ± 6 %	0.90 mho/m ± 6 %
Head TSL temperature during test	(22.0 ± 0.2) °C	---	---

SAR result with Head TSL

SAR averaged over 1 cm³ (1 g) of Head TSL	Condition	
SAR measured	250 mW input power	2.30 mW / g
SAR normalized	normalized to 1W	9.20 mW / g
SAR for nominal Head TSL parameters ¹	normalized to 1W	9.21 mW / g ± 17.0 % (k=2)

SAR averaged over 10 cm³ (10 g) of Head TSL	condition	
SAR measured	250 mW input power	1.51 mW / g
SAR normalized	normalized to 1W	6.04 mW / g
SAR for nominal Head TSL parameters ¹	normalized to 1W	6.05 mW / g ± 16.5 % (k=2)

¹ Correction to nominal TSL parameters according to d), chapter "SAR Sensitivities"

Appendix**Antenna Parameters with Head TSL**

Impedance, transformed to feed point	52.8 Ω - 3.3 j Ω
Return Loss	- 27.5 dB

General Antenna Parameters and Design

Electrical Delay (one direction)	1.394 ns
----------------------------------	----------

After long term use with 100W radiated power, only a slight warming of the dipole near the feedpoint can be measured.

The dipole is made of standard semirigid coaxial cable. The center conductor of the feeding line is directly connected to the second arm of the dipole. The antenna is therefore short-circuited for DC-signals.

No excessive force must be applied to the dipole arms, because they might bend or the soldered connections near the feedpoint may be damaged.

Additional EUT Data

Manufactured by	SPEAG
Manufactured on	April 23, 2003

DASY4 Validation Report for Head TSL

Date/Time: 24.05.2007 11:49:09

Test Laboratory: SPEAG, Zurich, Switzerland

DUT: Dipole 835 MHz; Type: D835V2; Serial: D835V2 - SN:481

Communication System: CW; Frequency: 835 MHz; Duty Cycle: 1:1

Medium: HSL 900 MHz;

Medium parameters used: $f = 835$ MHz; $\sigma = 0.9$ mho/m; $\epsilon_r = 41.6$; $\rho = 1000$ kg/m³

Phantom section: Flat Section

Measurement Standard: DASY4 (High Precision Assessment)

DASY4 Configuration:

- Probe: ET3DV6 - SN1507 (HF); ConvF(6.09, 6.09, 6.09); Calibrated: 19.10.2006
- Sensor-Surface: 4mm (Mechanical Surface Detection)
- Electronics: DAE4 Sn601; Calibrated: 30.01.2007
- Phantom: Flat Phantom 4.9L; Type: QD000P49AA; ;
- Measurement SW: DASY4, V4.7 Build 53; Postprocessing SW: SEMCAD, V1.8 Build 172

Pin = 250 mW; d = 15 mm/Zoom Scan (7x7x7)/Cube 0:

Measurement grid: dx=5mm, dy=5mm, dz=5mm

Reference Value = 55.0 V/m; Power Drift = -0.015 dB

Peak SAR (extrapolated) = 3.30 W/kg

SAR(1 g) = 2.3 mW/g; SAR(10 g) = 1.51 mW/g

Maximum value of SAR (measured) = 2.49 mW/g

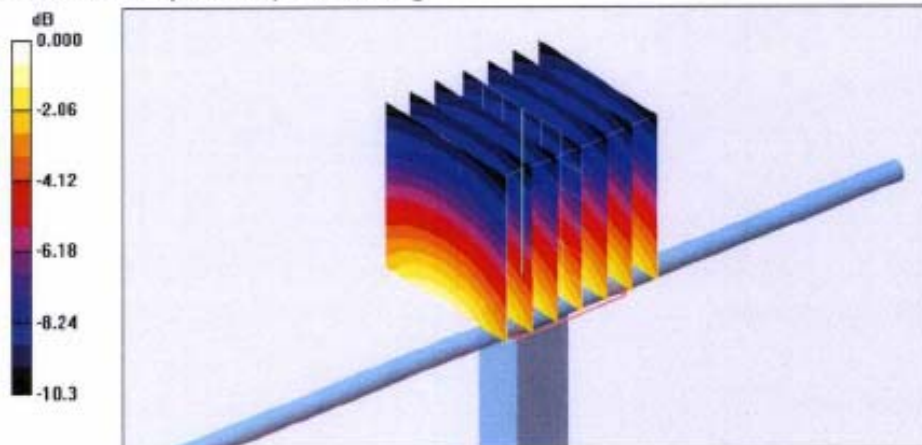

Impedance Measurement Plot for Head TSL

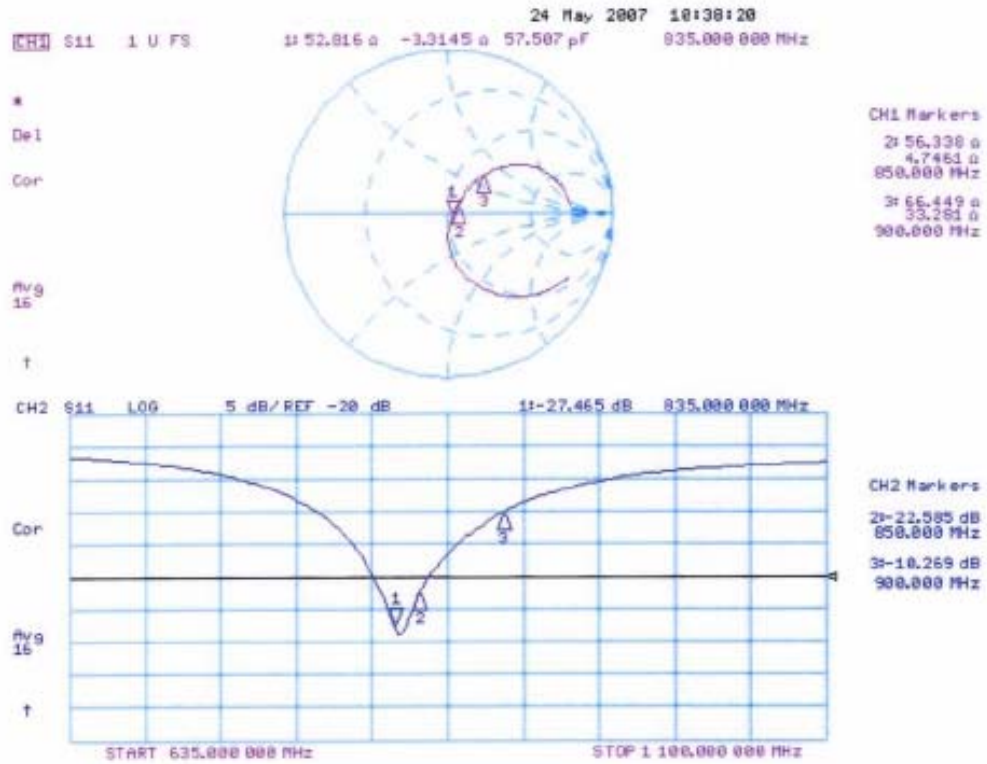

Calibration Laboratory of
Schmid & Partner
Engineering AG
Zeughausstrasse 43, 8004 Zurich, Switzerland



S Schweizerischer Kalibrierdienst
S Service suisse d'étalonnage
S Servizio svizzero di taratura
S Swiss Calibration Service

Accredited by the Swiss Federal Office of Metrology and Accreditation
The Swiss Accreditation Service is one of the signatories to the EA
Multilateral Agreement for the recognition of calibration certificates

Accreditation No.: **SCS 108**

Client **H-CT (Dymstec)**

Certificate No: **D1900V2-5d032_Feb07**

CALIBRATION CERTIFICATE

Object: **D1900V2 - SN: 5d032**

Calibration procedure(s): **QA CAL-05.v6
Calibration procedure for dipole validation kits**

Calibration date: **February 20, 2007**

Condition of the calibrated item: **In Tolerance**

This calibration certificate documents the traceability to national standards, which realize the physical units of measurements (SI).
The measurements and the uncertainties with confidence probability are given on the following pages and are part of the certificate.

All calibrations have been conducted in the closed laboratory facility: environment temperature (22 ± 3)°C and humidity < 70%.

Calibration Equipment used (M&TE critical for calibration)

Primary Standards	ID #	Cal Date (Calibrated by, Certificate No.)	Scheduled Calibration
Power meter EPM-442A	GB37480704	03-Oct-06 (METAS, No. 217-00608)	Oct-07
Power sensor HP 8481A	US37292783	03-Oct-06 (METAS, No. 217-00608)	Oct-07
Reference 20 dB Attenuator	SN: 5086 (20g)	10-Aug-06 (METAS, No 217-00591)	Aug-07
Reference 10 dB Attenuator	SN: 5047.2 (10r)	10-Aug-06 (METAS, No 217-00591)	Aug-07
Reference Probe ET3DV6	SN: 1507	19-Oct-06 (SPEAG, No. ET3-1507_Oct06)	Oct-07
DAE4	SN 601	30-Jan-07 (SPEAG, No. DAE4-601_Jan07)	Jan-08
Secondary Standards	ID #	Check Date (in house)	Scheduled Check
Power sensor HP 8481A	MY41092317	18-Oct-02 (SPEAG, in house check Oct-05)	In house check: Oct-07
RF generator Agilent E4421B	MY41000675	11-May-05 (SPEAG, in house check Nov-05)	In house check: Nov-07
Network Analyzer HP 8753E	US37390585 S4206	18-Oct-01 (SPEAG, in house check Oct-06)	In house check: Oct-07

Calibrated by: **Name: Mike Meili, Function: Laboratory Technician, Signature: [Signature]**

Approved by: **Name: Katja Pokovic, Function: Technical Manager, Signature: [Signature]**

Issued: February 21, 2007

This calibration certificate shall not be reproduced except in full without written approval of the laboratory.

Calibration Laboratory of
Schmid & Partner
Engineering AG
Zeughausstrasse 43, 8004 Zurich, Switzerland



S Schweizerischer Kalibrierdienst
C Service suisse d'étalonnage
S Servizio svizzero di taratura
S Swiss Calibration Service

Accredited by the Swiss Federal Office of Metrology and Accreditation
The Swiss Accreditation Service is one of the signatories to the EA
Multilateral Agreement for the recognition of calibration certificates

Accreditation No.: **SCS 108**

Glossary:

TSL tissue simulating liquid
ConvF sensitivity in TSL / NORM x,y,z
N/A not applicable or not measured

Calibration is Performed According to the Following Standards:

- a) IEEE Std 1528-2003, "IEEE Recommended Practice for Determining the Peak Spatial-Averaged Specific Absorption Rate (SAR) in the Human Head from Wireless Communications Devices: Measurement Techniques", December 2003
- b) CENELEC EN 50361, "Basic standard for the measurement of Specific Absorption Rate related to human exposure to electromagnetic fields from mobile phones (300 MHz - 3 GHz), July 2001
- c) Federal Communications Commission Office of Engineering & Technology (FCC OET), "Evaluating Compliance with FCC Guidelines for Human Exposure to Radiofrequency Electromagnetic Fields; Additional Information for Evaluating Compliance of Mobile and Portable Devices with FCC Limits for Human Exposure to Radiofrequency Emissions", Supplement C (Edition 01-01) to Bulletin 65

Additional Documentation:

- d) DAS4 System Handbook

Methods Applied and Interpretation of Parameters:

- *Measurement Conditions:* Further details are available from the Validation Report at the end of the certificate. All figures stated in the certificate are valid at the frequency indicated.
- *Antenna Parameters with TSL:* The dipole is mounted with the spacer to position its feed point exactly below the center marking of the flat phantom section, with the arms oriented parallel to the body axis.
- *Feed Point Impedance and Return Loss:* These parameters are measured with the dipole positioned under the liquid filled phantom. The impedance stated is transformed from the measurement at the SMA connector to the feed point. The Return Loss ensures low reflected power. No uncertainty required.
- *Electrical Delay:* One-way delay between the SMA connector and the antenna feed point. No uncertainty required.
- *SAR measured:* SAR measured at the stated antenna input power.
- *SAR normalized:* SAR as measured, normalized to an input power of 1 W at the antenna connector.
- *SAR for nominal TSL parameters:* The measured TSL parameters are used to calculate the nominal SAR result.

Measurement Conditions

DASY system configuration, as far as not given on page 1.

DASY Version	DASY4	V4.7
Extrapolation	Advanced Extrapolation	
Phantom	Modular Flat Phantom V5.0	
Distance Dipole Center - TSL	10 mm	with Spacer
Zoom Scan Resolution	dx, dy, dz = 5 mm	
Frequency	1900 MHz \pm 1 MHz	

Head TSL parameters

The following parameters and calculations were applied.

	Temperature	Permittivity	Conductivity
Nominal Head TSL parameters	22.0 °C	40.0	1.40 mho/m
Measured Head TSL parameters	(22.0 \pm 0.2) °C	38.8 \pm 6 %	1.43 mho/m \pm 6 %
Head TSL temperature during test	(21.0 \pm 0.2) °C	----	----

SAR result with Head TSL

SAR averaged over 1 cm ³ (1 g) of Head TSL	condition	
SAR measured	250 mW input power	9.55 mW / g
SAR normalized	normalized to 1W	38.2 mW / g
SAR for nominal Head TSL parameters ¹	normalized to 1W	37.2 mW / g \pm 17.0 % (k=2)

SAR averaged over 10 cm ³ (10 g) of Head TSL	Condition	
SAR measured	250 mW input power	5.03 mW / g
SAR normalized	normalized to 1W	20.1mW / g
SAR for nominal Head TSL parameters ¹	normalized to 1W	19.8 mW / g \pm 16.5 % (k=2)

¹ Correction to nominal TSL parameters according to d), chapter "SAR Sensitivities"

Appendix**Antenna Parameters with Head TSL**

Impedance, transformed to feed point	53.5 Ω + 3.3 j Ω
Return Loss	- 26.6 dB

General Antenna Parameters and Design

Electrical Delay (one direction)	1.192 ns
----------------------------------	----------

After long term use with 100W radiated power, only a slight warming of the dipole near the feedpoint can be measured.

The dipole is made of standard semirigid coaxial cable. The center conductor of the feeding line is directly connected to the second arm of the dipole. The antenna is therefore short-circuited for DC-signals.

No excessive force must be applied to the dipole arms, because they might bend or the soldered connections near the feedpoint may be damaged.

Additional EUT Data

Manufactured by	SPEAG
Manufactured on	March 17, 2003

DASY4 Validation Report for Head TSL

Date/Time: 20.02.2007 14:35:32

Test Laboratory: SPEAG, Zurich, Switzerland

DUT: Dipole 1900 MHz; Type: D1900V2; Serial: D1900V2 - SN:5d032

Communication System: CW; Frequency: 1900 MHz; Duty Cycle: 1:1

Medium: HSL U10 BB;

Medium parameters used: $f = 1900$ MHz; $\sigma = 1.43$ mho/m; $\epsilon_r = 38.9$; $\rho = 1000$ kg/m³

Phantom section: Flat Section

Measurement Standard: DASY4 (High Precision Assessment)

DASY4 Configuration:

- Probe: ET3DV6 - SN1507 (HF); ConvF(4.97, 4.97, 4.97); Calibrated: 19.10.2006
- Sensor-Surface: 4mm (Mechanical Surface Detection)
- Electronics: DAE4 Sn601; Calibrated: 30.01.2007
- Phantom: Flat Phantom 5.0 (front); Type: QD000P50AA
- Measurement SW: DASY4, V4.7 Build 53; Postprocessing SW: SEMCAD, V1.8 Build 172

Pin = 250 mW; d = 10 mm/Zoom Scan (7x7x7)/Cube 0:

Measurement grid: dx=5mm, dy=5mm, dz=5mm

Reference Value = 90.3 V/m; Power Drift = 0.006 dB

Peak SAR (extrapolated) = 16.4 W/kg

SAR(1 g) = 9.55 mW/g; SAR(10 g) = 5.03 mW/g

Maximum value of SAR (measured) = 10.5 mW/g

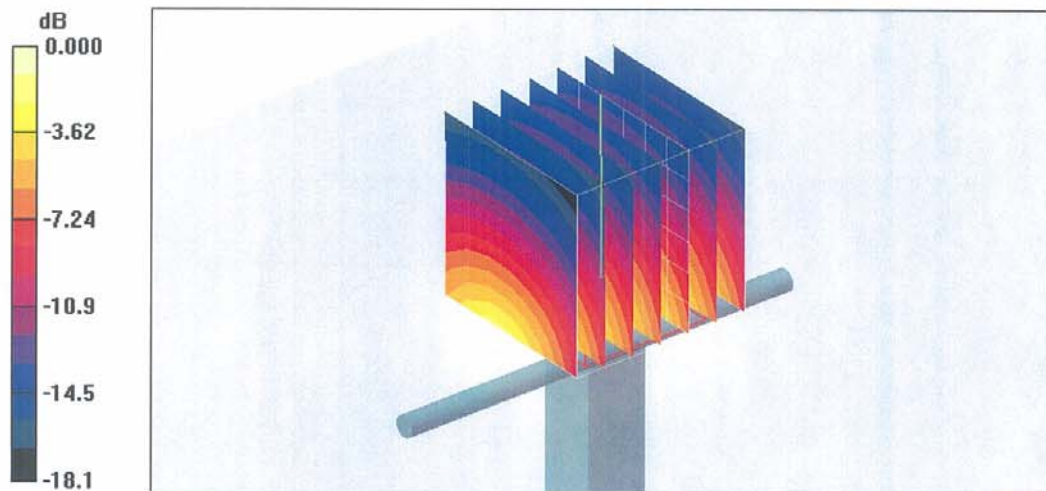

0 dB = 10.5mW/g

Impedance Measurement Plot for Head TSL

