



HYUNDAI CALIBRATION & CERTIFICATION TECH. CO., LTD.

PRODUCT COMPLIANCE DIVISION
SAN 136-1, AMI-RI, BUBAL-EUP, ICHEON-SI, KYOUNGKI-DO, 467-701, KOREA
TEL : +82 31 639 8518 FAX : +82 31 639 8525 www.hctec.co.kr



CERTIFICATE OF COMPLIANCE

FCC Part 22 Certification

HYUNDAI CURITEL INC.
SAN 136-1, AMI-RI, BUBAL-EUP, ICHEON-SI,
KYOUNGKI-DO, 467-701, KOREA

FRN: 0006-2784-69

Date of Issue : March 25, 2002

Test Report No.: HCT-RF02-0301

Test Site: HYUNDAI CALIBRATION & CERTIFICATION
TECHNOLOGIES CO., LTD.

FRN: 0005-8642- 21

FCC ID

:

PP4DX-22B

APPLICANT

:

HYUNDAI CURITEL INC.

EUT Type: Dual-Mode Cellular Phone (AMPS/CDMA)
Tx Frequency: 824.04 — 848.97 MHz (AMPS) / 824.70 — 848.31 MHz (CDMA)
Rx Frequency: 869.04 — 893.97 MHz (AMPS) / 869.70 — 893.31 MHz (CDMA)
Max. RF Output Power: 0.452W ERP AMPS (26.553 dBm) / 0.325W ERP CDMA (25.113 dBm)
Trade Name/Model(s): HYUNDAI / DX-22B
FCC Classification: Licensed Portable Transmitter Held to Ear (PCE)
Application Type: Certification
FCC Rule Part(s): §22(H), §2
Maximum SAR: 0.878 W/kg AMPS Brain SAR / 0.446 W/kg AMPS Body SAR
0.536 W/kg CDMA Brain SAR / 0.307 W/kg CDMA Body SAR
Antenna Specifications: Manufacturer: ACE TECHNOLOGY Model: DX-22B/ Length=3.41cm
Emission Designator(s): 40K0F8W, 40K0F1D, 1M25F9W

This equipment has been shown to be capable of compliance with the applicable technical standards as indicated in the measurement report and was tested in accordance with the measurement procedures specified in 2.947.

I attest to the accuracy of data. All measurements reported herein were performed by me or were made under my supervision and are correct to the best of my knowledge and belief. I assume full responsibility for the completeness of these measurements and vouch for the qualifications of all persons taking them.

Hyundai C-Tech Co., Ltd. Certifies that no party to this application has been denied FCC benefits pursuant to section 5301 of the Anti- Drug Abuse Act of 1998, 21 U.S. C. 853(a)

Report prepared by : Ki-Soo Kim

Manager of Product Compliance Team



Table of Contents

ATTACHMENT A: COVER LETTER(S)	
ATTACHMENT B: ATTESTATION STATEMENT(S)	
ATTACHMENT C: TEST REPORT	
1.1 SCOPE -----	3
2.1 INTRODUCTION -----	4
3.1 INSERTS PER §2.1033(d)-----	5
4.1 DESCRIPTION OF TESTS-----	6-15
5.1 EFFECTIVE RADIATED POWER OUTPUT -----	16-17
6.1 RADIATED MEASUREMENTS-----	18-23
7.1 FREQUENCY STABILITY -----	24-25
8.1 PLOTS OF EMISSIONS-----	26
9.1 LIST OF TEST EQUIPMENT -----	27
10.1 SAMPLE CALCULATIONS -----	28
11.1 CONCLUSION-----	29
ATTACHMENT D: TEST PLOTS	
ATTACHMENT E: FCC ID LABEL & LOCATION	
ATTACHMENT F: TEST SETUP PHOTOGRAPHS	
ATTACHMENT G: EXTERNAL PHOTOGRAPHS	
ATTACHMENT H: INTERNAL PHOTOGRAPHS	
ATTACHMENT I: BLOCK DIAGRAM (S)	
ATTACHMENT J: CIRCUIT DIAGRAMS & DESCRIPTION	
ATTACHMENT K: PARTS LIST/TUNE UP PROCEDURE	
ATTACHMENT L: OPERATIONAL DESCRIPTION	
ATTACHMENT M: USER'S MANUAL	
ATTACHMENT N: SAR MEASUREMENT REPORT	
ATTACHMENT O: SAR TEST DATA	
ATTACHMENT P: SAR TEST SETUP PHOTOGRAPHS	
ATTACHMENT Q: DIPOLE VALIDATION	
ATTACHMENT R: PROBE CALIBRATION	
ATTACHMENT S: DIPOLE CALIBRATION	

MEASUREMENT REPORT

1.1 SCOPE

Measurement and determination of electromagnetic emissions (EME) of radio frequency devices including intentional and/or unintentional radiators for compliance with the technical rules and regulations of the Federal Communications Commission.

General Information

Company Name:	HYUNDAI CURITEL INC.
Address:	San 136-1, Ami-Ri, Bubal-Eub, Ichon-Si, Kyoungki-Do, KOREA 467-701
Attention:	Mr. Hong-Ki Kim
Tel. / Fax :	82- 31- 630- 3270 / 82- 31- 630- 8085

- FCC ID: **PP4DX-22B**
- Quantity: Quantity production is planned
- EUT Type: Dual-Mode Cellular Phone (AMPS/CDMA)
- Trade Name: **HYUNDAI**
- Model(s): **DX-22B**
- Serial Number(s): 20020000003
- Emission Designator(s): 40K0F8W, 40K0F1D, 1M25F9W
- Tx Frequency: 824.04 – 848.97 MHz (AMPS)
824.70 – 848.31 MHz (CDMA)
- Rx Frequency: 869.04 – 893.97 MHz (AMPS)
869.70 – 893.31 MHz (CDMA)
- Application Type: Certification
- FCC Classification: Licensed Portable Transmitter Held to Ear (PCE)
- FCC Rule Part(s): § 2.1093, Docket 96-326
- Modulation(s): AMPS/ CDMA
- Antenna Type: Fixed
- Max RF. Output Power: 0.452W ERP AMPS (26.553 dBm)
0.325W ERP CDMA (25.113 dBm)
- Date(s) of Tests: February 20, 2002 – March 20, 2002
- Place of Tests: Hyundai C-Tech. EMC Lab.
Icheon, Kyounki-Do, KOREA
- Report Serial No.: HCT-RF02-0301

2.1 INTRODUCTION

EUT DESCRIPTION

The Hyundai Curitel DX-22B is a Dual-Mode Cellular Phone (AMPS/ CDMA) phone. Its basic purpose is used for communications. It transmits from AMPS(824.04~848.97), CDMA(824.70~848.31) and receives from AMPS(869.04~893.97), CDMA(869.70~893.31). The RF power is rated at AMPS(0.452W), CDMA(0.325W).

MEASURING INSTRUMENT CALIBRATION

The measuring equipment, which was utilized in performing the tests documented herein, has been calibrated in accordance with the manufacturer's recommendations for utilizing calibration equipment, which is traceable to recognized national standards.

Test Facility

The open area test site and conducted measurement facility used to collect the radiated data are located at the 254-1, Maekok-Ri, Hobup-Myun, Ichon-Si, Kyoungki-Do, 467-701, KOREA. The site is constructed in conformance with the requirements of ANSI C63.4 and CISPR Publication 22. Detailed description of test facility was submitted to the Commission and accepted dated July 24, 2000(Confirmation Number: EA90661)

3.1 INSERTS

Function of Active Devices (Confidential)

The Function of active devices are shown in Attachment K.

Block/Circuit Diagrams & Description (Confidential)

The circuit diagrams & description are shown in Attachment J, and the block diagrams are shown in Attachment I.

Operating Instructions

The instruction manual is shown in Attachment M.

Parts List & Tune-Up Procedure (Confidential)

The parts list & tune-up procedure are shown in Attachment L.

Description of Freq. Stabilization Circuit (Confidential)

The description of frequency stabilization circuit is shown in Attachment K.

Description for Suppression of Spurious Radiation, for Limiting Modulation, and Harmonic Suppresion Circuits (Confidential)

The description of suppression stabilization circuits are shown in Attachment K

4.1 DESCRIPTION OF TESTS

4.1 RF Power output.

Test Set-up

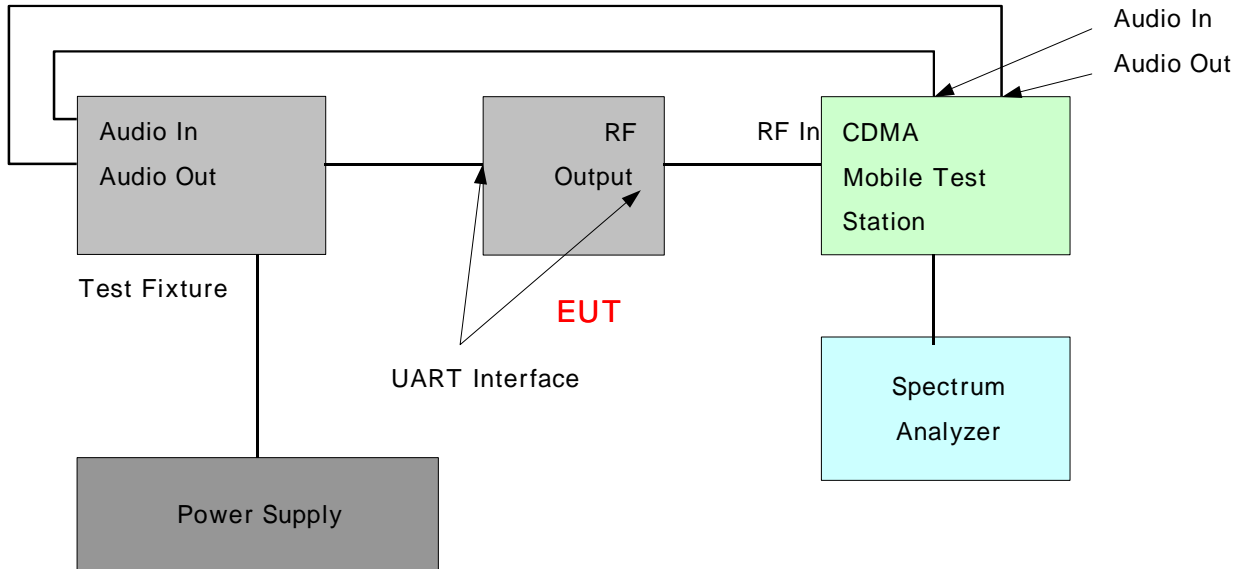

UART Interface: The UART Interface has a serial communication link and RF Interface port that can be used to test , debug or upgrade the phone's functions and characteristics.

EUT : Equipment Under Test

Test Procedure

The power is read at the specturm anlyzer through the duplex port of CDMA mobile test station.

RF power output is measured at the RF output terminal (UART Interface) on the bottom side of the EUT.

4.2 Effective Radiated Power.

Test Set-up

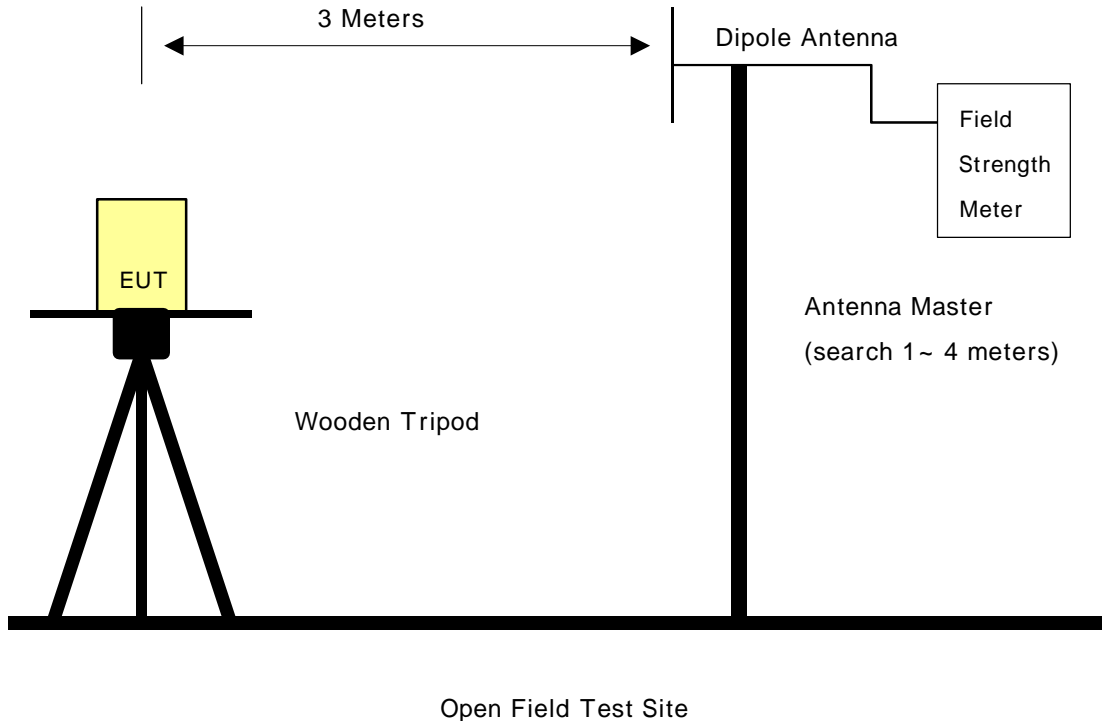

Test Procedure

The measurement facilities used for this test have been documented in previous filings with the commission pursuant to section 2.948.

The open field test site is situated in open field with ground screen whose site attenuation characteristics meet ANSI C63.4 –1992. A mast capable of lifting the receiving antenna from a height of one to four meters is used together with a rotatable wooden platform mounted at three from the antenna mast.

- 1) The EUT mounted on a wooden tripod is 0.8 meter above test site ground level.
- 2) During the test , the turn table is rotated and the antenna height is also varied from 1 to 4 meters until the maximum signal is found.
- 3) Record the field strength meter's level.
- 4) Replace the EUT with $\lambda / 2$ dipole antenna that is connected to a calibrated signal generator.
- 5) Increase the signal generator output till the field strength meter's level is equal to the item(4).
- 6) The signal generator output level is the rating of effective radiated power(ERP).
- 7) The instrument settings used (RBW/ VBW) during ERP/ EIRP output power measurement are as Belows ;
 - . Below 1GHz : RBW 100KHz, VBW 300KHz
 - . Above 1GHz : RBW 1MHz, VBW 1MHz

4.3 Modulation Requirements.

4.3.1 Frequency response of the audio modulation circuit.

Test Set-up

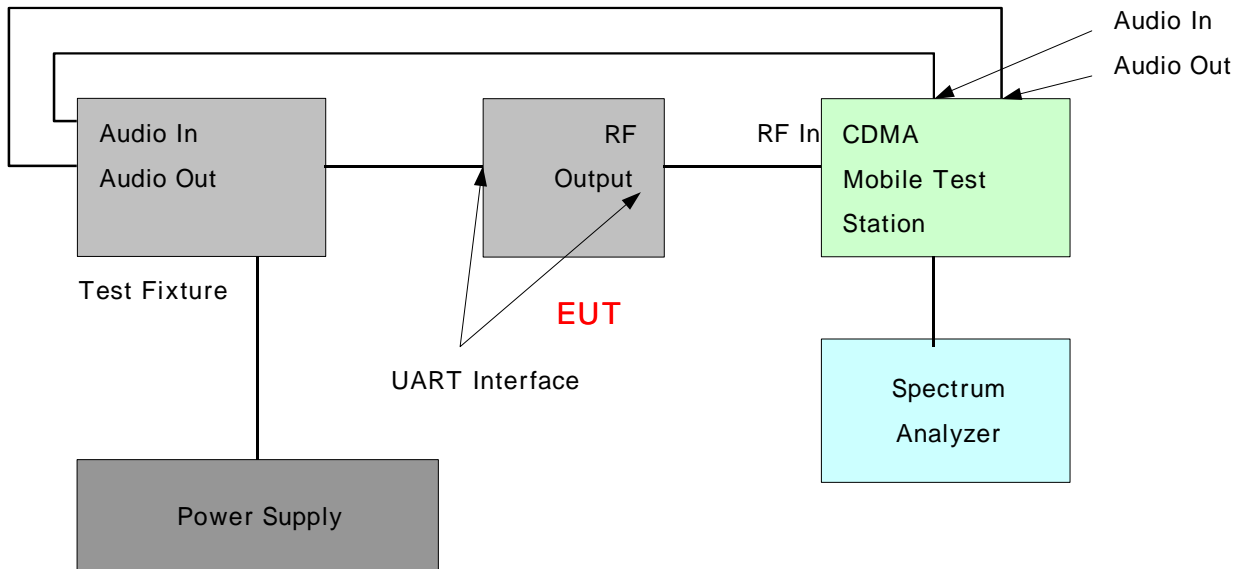

UART Interface: The UART Interface has a serial communication link that can be used to test , debug or upgrade the phone's functions and characteristics.

Test Procedure

- 1) Set the frequency deviation 2.9KHz at the audio tone by adjusting the audio generator and record the demod out level at 1KHz.
- 2) Change the frequency of audio generator from 300KHz to 3000Hz and record the demod out level relative to the level at 1KHz.
- 3) Adjust the audio input frequency to 1000KHz and adjust the input level to 20dB greater than that required to produce 8KHz deviation.
- 4) Change the frequency of audio generator from 3000Hz to 30,000Hz and record the demod out level relative to the level at 1KHz.

4.3.2 Modulation levels and response of modulation limiting circuitry.

Test Set-up

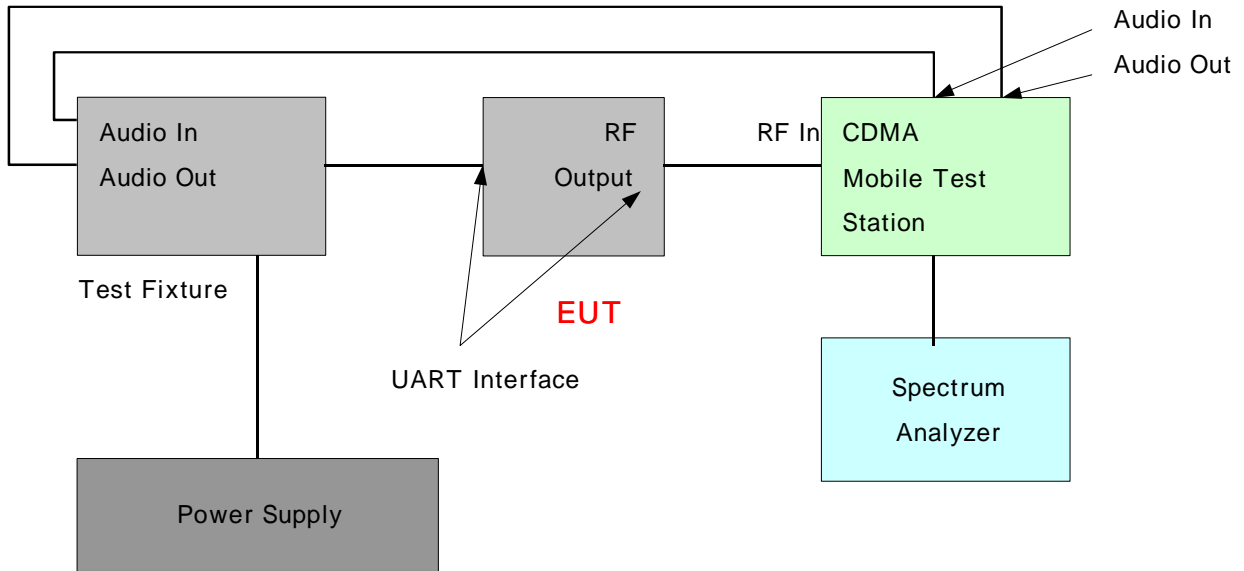

UART Interface: The UART Interface has a serial communication link that can be used to test , debug or upgrade the phone's functions and characteristics.

Test Procedure

- 1) Set the frequency deviation 7.2KHz at the audio tone by adjusting the audio generator. This level will be the 0 dB reference.
- 2) Increase the audio level from 0 dB reference to 30 dB in increments of 5 dB and record the frequency deviation.
- 3) This measurement is then repeated at 300Hz, 500Hz, 2000Hz and 3000Hz audio tone.

4.3.3 Levels of modulating signals.

Test Set-up

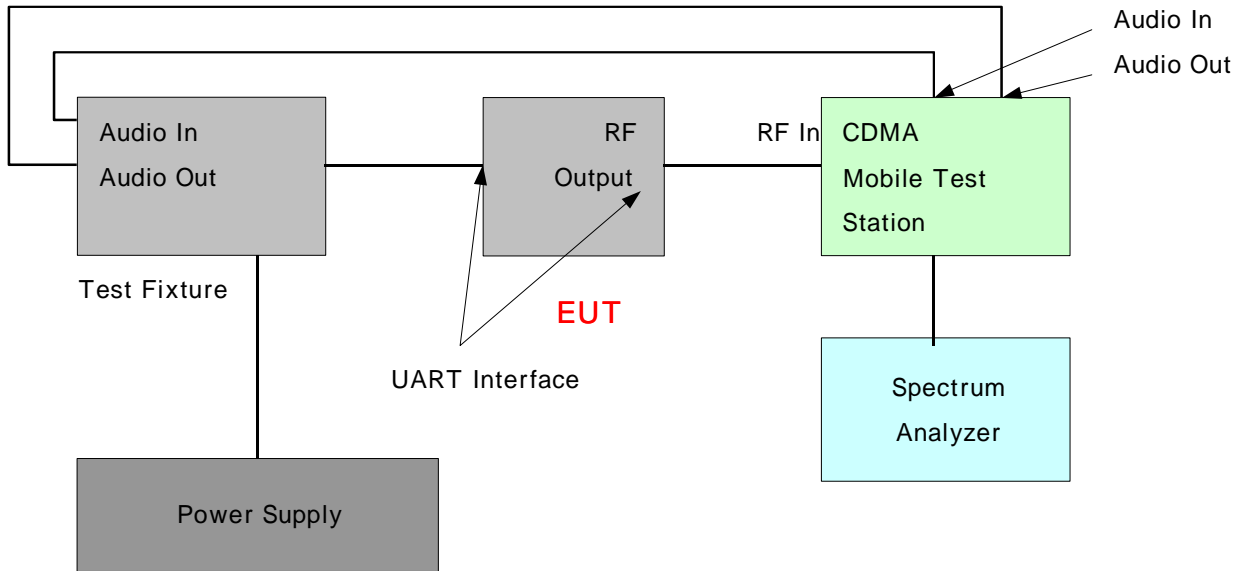

UART Interface: The UART Interface has a serial communication link that can be used to test , debug or upgrade the phone's functions and characteristics.

Test Procedure

- 1) Select the supervisory audio tone test mode pursuant to "Tune – up procedure" and record the frequency deviation on the modulation analyzer.
- 2) Select the signalling tone test mode pursuant to "Tune – up procedure" and record the frequency deviation on the modulation analyzer.
- 3) Select the TX data test mode pursuant to "Tune – up procedure" and record the frequency deviation on the modulation analyzer .

4.3.4 Occupied bandwidth.

Test Set-up

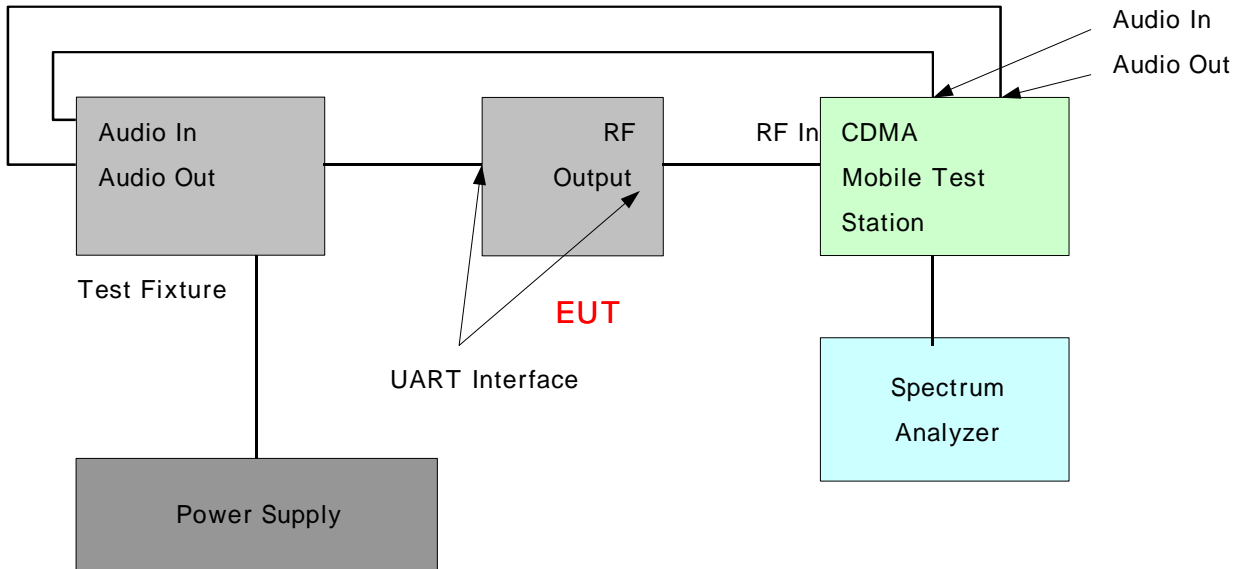

UART Interface: The UART Interface has a serial communication link that can be used to test , debug or upgrade the phone's functions and characteristics.

Test Procedure

1. F3E radiotelephony mode.
 - 1) The audio generator is set on the frequency of maximum audio response of the audio modulating circuit and its level adjusted for 50% modulation.
 - 2) Increase the audio level 16 dB greater than that necessary to produce 50 percent modulation and change the audio frequency to 2,500 Hz tone.
 - 3) The occupied bandwidth is drawn from the spectrum analyzer display.
2. F1D wideband data mode.
 - 1) Select the TX data test mode pursuant to "Tune-up procedure ".
 - 2) The occupied bandwidth is drawn from the spectrum analyzer display.
3. F3D supervisory audio tone mode.
 - 1) Select the supervisory tone test mode pursuant to "Tune-up procedure ".
 - 2) The occupied bandwidth is drawn from the spectrum analyzer display.
4. F3D signalling tone mode.
 - 1) Select the signalling audio tone test mode pursuant to "Tune-up procedure ".
 - 2) The occupied bandwidth is drawn from the spectrum analyzer display.

4.3.5 Spurious and Harmonic Emissions at Antenna Terminal.

Test Set-up

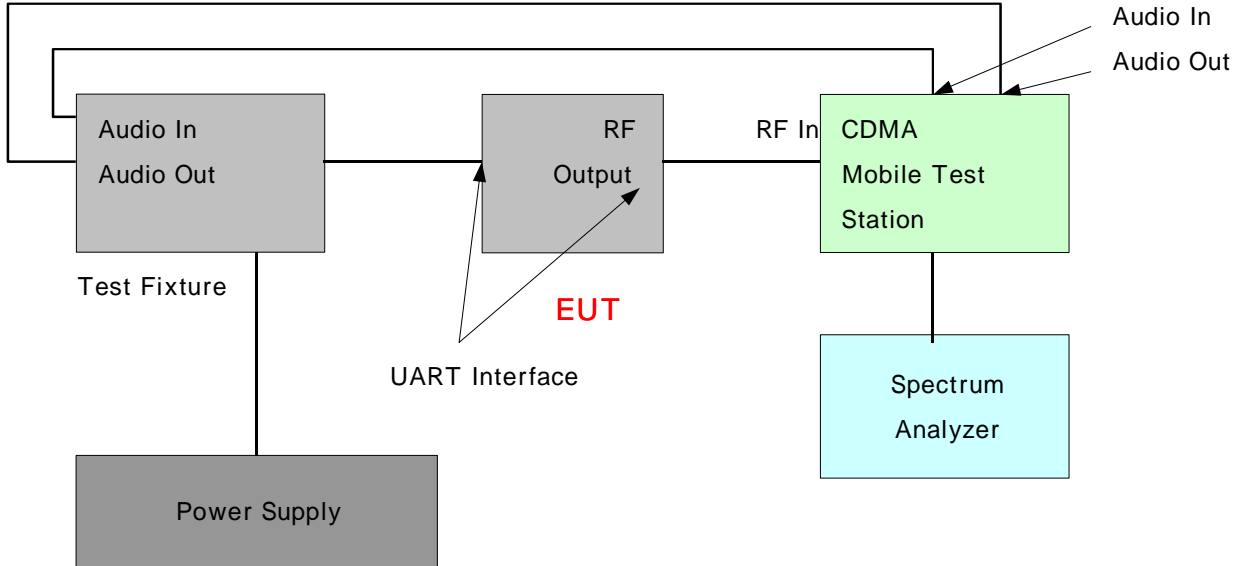

Test Procedure

The level of the carrier and the various conducted spurious and harmonic frequencies is measured by means of a calibrated spectrum analyzer. The spectrum is scanned from the lowest frequency generated in the equipment up to 10 GHz. The transmitter is modulated with a 2500Hz tone at a level of 16dB greater than that required to provide 50% modulation. At the input terminals of the spectrum analyzer, an isolator (RF circulator with one port terminated with 50 ohms) and an 870 MHz to 890 MHz bandpass filter is connected between the test transceiver (for conducted tests) or the receive antenna (for radiated tests) and the analyzer. The rejection of the bandpass filter to signals in the 825 — 845 MHz range is adequate to limit the transmit energy from the test transceiver which appears to a level which will allow the analyzer to measure signals less than —90dBm. Calibration of the test receiver is performed in the 870 — 890 MHz range to insure accuracy to allow variation in the bandpass filter insertion loss to be calibrated.

4.3.6 Field strength of spurious radiation .

Test Set-up

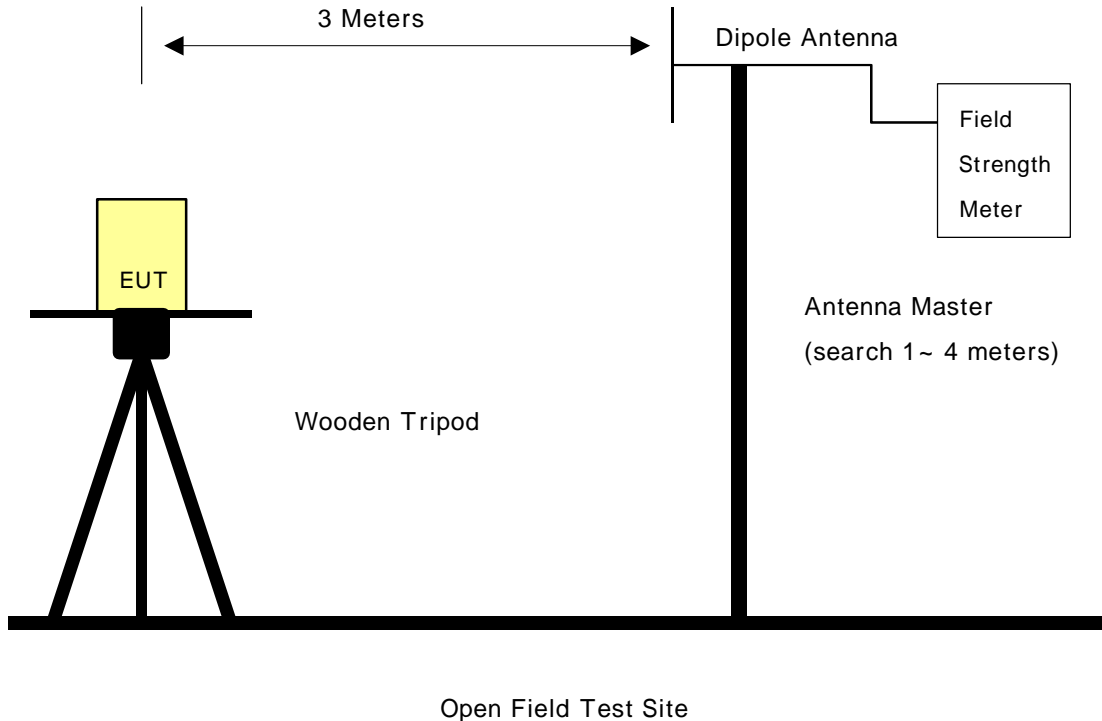

Test Procedure

The measurement facilities used for this test have been documented in previous filings with the commission pursuant to section 2.948.

The open field test site is situated in open field with ground screen whose site attenuation characteristics meet ANSI C63.4 –1992. A mast capable of lifting the receiving antenna from a height of one to four meters is used together with a rotatable wooden platform mounted at three from the antenna mast.

- 1) The unit mounted on a wooden table 1.5m 1.0m 0.80 is 0.8 meter above test site ground level.
- 2) During the emission test , the turntable is rotated and the EUT is manipulated to find the configuration resulting in maximum emission under normal condition of installation and operation.
- 3) The antenna height and polarization are also varied from 1 to 4 meters until the maximum signal is found.
- 4) The spectrum shall be scanned up to the 10th harmonic of the fundamental frequency.
- 5) The instrument settings used (RBW/ VBW) during ERP/ EIRP output power measurement are as follows ;
 - Below 1GHz : RBW 100KHz, VBW 300KHz
 - Above 1GHz : RBW 1MHz, VBW 1MHz

4.3.7 Frequency stability .

4.3.7.1 Frequency stability with variation of ambient temperature.

Test Set-up

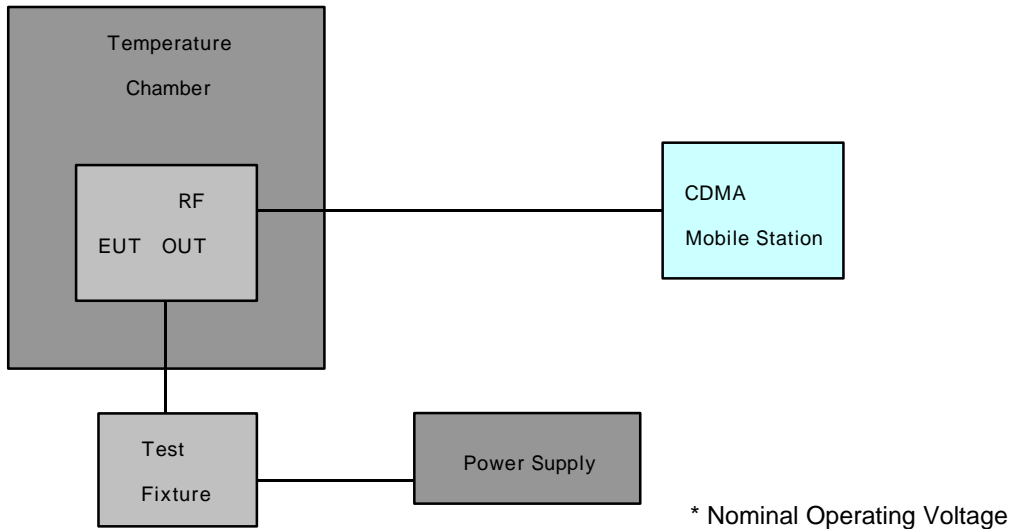

Test Procedure

The frequency stability of the transmitter is measured by:

- a.) **Temperature:** The temperature is varied from -30 °C to +60 °C using an environmental chamber.
- b.) **Primary Supply Voltage:** The primary supply voltage is varied from 85% to 115% of the voltage normally at the input to the device or at the power supply terminals if cables are not normally supplied.

Specification — The frequency stability shall be sufficient to ensure that the fundamental emission stays within the authorized frequency block. The frequency stability of the transmitter shall be maintained within ± 0.0001 (± 1 ppm) of the center frequency.

Time Period and Procedure:

1. The carrier frequency of the transmitter and the individual oscillators is measured at room temperature (25 °C to 27 °C to provide a reference).
2. The equipment is subjected to an overnight “soak” at -30 °C without any power applied.
3. After the overnight “soak” at 30 °C (usually 14-16 hours), the equipment is turned on in a “standby” condition for one minute before applying power to the transmitter. Measurement of the carrier frequency of the transmitter and the individual oscillators is made within a three minute interval after applying power to the transmitter.
4. Frequency measurements are made at 10 °C interval up to room temperature. At least a period of one and one half-hour is provided to allow stabilization of the equipment at each temperature level.
5. Again the transmitter carrier frequency and the individual oscillators is measured at room temperature to begin measurement of the upper temperature levels.
6. Frequency were made at 10 intervals starting at 30 °C up to +50 °C allowing at least two hours at each temperature for stabilization. In all measurements the frequency is measured within three minutes after applying power to the transmitter.
7. The artificial load is mounted external to the temperature chamber.

NOTE: The EUT is tested down to the battery endpoint.

4.3.7.2 Frequency stability with variation of primary supply voltage.

Test Set-up

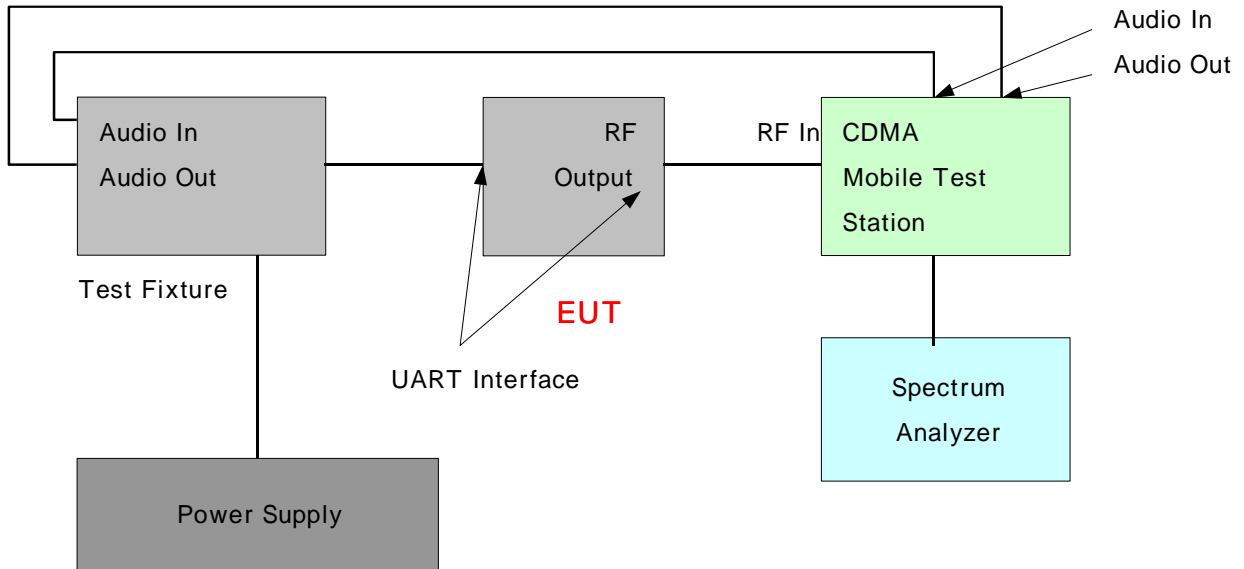

Test Procedure

- 1) The primary supply is varied in steps of 5% from 85 to 115% of the nominal supply voltage, or reduce primary supply voltage to the battery operating end point.
- 2) The frequency is recorded each 5% step.

5.1 Test Data

5.2 Effective Radiated Power Output

A. POWER: Low (Analog Mode)

Freq. Tuned (MHz)	LEVEL (dBm)	POL (H/V)	ERP (W)	ERP (dBm)
824.04	-49.00	H	0.003	5.023
836.49	-49.40	H	0.003	4.623
848.97	-50.40	H	0.002	3.623

B. POWER: High (Analog Mode)

Freq. Tuned (MHz)	LEVEL (dBm)	POL (H/V)	ERP (W)	ERP (dBm)	BATTERY
824.04	-11.3	H	0.429	26.323	Standard
836.49	-11.2	H	0.439	26.423	Standard
848.97	-11.7	H	0.452	26.553	Standard

Note: Standard and Extended batteries are both battery options for this phone

NOTES:

Effective Radiated Power Output Measurements by Substitution Method according to ANSI/TIA/EIA-603 (rev.1998):

The EUT was placed on a wooden turn table 3-meters from the receive antenna. The receive antenna height and turntable rotation was adjusted for the highest reading on the receive spectrum analyzer. A half-wave dipole was substituted in place of the EUT. This dipole antenna was driven by a signal generator and the level of the signal generator was adjusted to obtain the same receive spectrum analyzer reading. The conducted power at the terminals of the dipole is measured. The ERP is recorded.

5.1 Test Data (Continued)

5.3 Effective Radiated Power Output (CDMA)

Radiated measurements at 3 meters

Modulation: CDMA

Freq. Tuned (MHz)	LEVEL (dBm)	POL (H/V)	ERP (W)	ERP (dBm)	BATTERY
824.70	-12.63	H	0.316	24.993	Standard
835.89	-12.55	H	0.322	25.073	Standard
848.31	-12.51	H	0.325	25.113	Standard

Note: Standard and Extended batteries are both battery options for this phone

NOTES:

Effective Radiated Power Output Measurements by Substitution Method according to ANSI/TIA/EIA-603 (rev.1998):

The EUT was placed on a wooden turn table 3-meters from the receive antenna. The receive antenna height and turntable rotation was adjusted for the highest reading on the receive spectrum analyzer. A half-wave dipole was substituted in place of the EUT. This dipole antenna was driven by a signal generator and the level of the signal generator was adjusted to obtain the same receive spectrum analyzer reading. The conducted power at the terminals of the dipole is measured. The ERP is recorded.

6.1 Test Data (Continued)

6.2 AMPS Radiated Measurements

Field Strength of SPURIOUS Radiation

OPERATING FREQUENCY:	<u>824.04 MHz</u>
CHANNEL:	<u>0991 (Low)</u>
MEASURED OUTPUT POWER:	<u>26.553dBm = 0.452 W</u>
MODULATION SIGNAL:	<u>FM</u>
DISTANCE:	<u>3 meters</u>
LIMIT: $43 + 10 \log_{10} (W) =$	<u>39.55 dBc</u>

Freq. (MHz)	LEVEL (dBm)	POL (H / V)	(dBc)
1648.08	-67.00	H	54.4
2472.12	- 130		
3296.16	- 130		
4120.20	- 130		

NOTES:

Radiated Spurious Emission Measurements by Substitution Method according to ANSI/TIA/EIA-603 (rev.1998):

The EUT was placed on a wooden turn table 3-meters from the receive antenna. The receive antenna height and turntable rotation was adjusted for the highest reading on the receive spectrum analyzer. A half-wave dipole was substituted in place of the EUT. This dipole antenna was driven by a signal generator and the level of the signal generator was adjusted to obtain the same receive spectrum analyzer reading. This spurious level is recorded. For readings above 1GHz, the above procedure is repeated using horn antennas and the difference between the gain of the horn and an isotropic or dipole antenna are taken into consideration.

6.1 Test Data (Continued)

6.3 AMPS Radiated Measurements

Field Strength of SPURIOUS Radiation

OPERATING FREQUENCY:	<u>836.49 MHz</u>
CHANNEL:	<u>0383 (Mid)</u>
MEASURED OUTPUT POWER:	<u>26.553dBm = 0.452 W</u>
MODULATION SIGNAL:	<u>FM</u>
DISTANCE:	<u>3 meters</u>
LIMIT: $43 + 10 \log_{10} (W) =$	<u>39.55 dBc</u>

Freq. (MHz)	LEVEL (dBm)	POL (H / V)	(dBc)
1672.98	- 72.33	H	59.7
2509.47	- 130		
3345.96	- 130		
4182.45	- 130		

NOTES:

Radiated Spurious Emission Measurements by Substitution Method according to ANSI/TIA/EIA-603 (rev.1998):

The EUT was placed on a wooden turn table 3-meters from the receive antenna. The receive antenna height and turntable rotation was adjusted for the highest reading on the receive spectrum analyzer. A half-wave dipole was substituted in place of the EUT. This dipole antenna was driven by a signal generator and the level of the signal generator was adjusted to obtain the same receive spectrum analyzer reading. This spurious level is recorded. For readings above 1GHz, the above procedure is repeated using horn antennas and the difference between the gain of the horn and an isotropic or dipole antenna are taken into consideration.

6.1 Test Data (Continued)

6.4 AMPS Radiated Measurements

Field Strength of SPURIOUS Radiation

OPERATING FREQUENCY:	<u>849.97 MHz</u>
CHANNEL:	<u>0799 (High)</u>
MEASURED OUTPUT POWER:	<u>26.553dBm = 0.452 W</u>
MODULATION SIGNAL:	<u>FM</u>
DISTANCE:	<u>3 meters</u>
LIMIT: $43 + 10 \log_{10} (W) =$	<u>39.55 dBc</u>

Freq. (MHz)	LEVEL (dBm)	POL (H / V)	(dBc)
1697.94	- 74.99	H	62.4
2546.91	- 130		
3395.88	- 130		
4244.85	- 130		

NOTES:

Radiated Spurious Emission Measurements by Substitution Method according to ANSI/TIA/EIA-603 (rev.1998):

The EUT was placed on a wooden turn table 3-meters from the receive antenna. The receive antenna height and turntable rotation was adjusted for the highest reading on the receive spectrum analyzer. A half-wave dipole was substituted in place of the EUT. This dipole antenna was driven by a signal generator and the level of the signal generator was adjusted to obtain the same receive spectrum analyzer reading. This spurious level is recorded. For readings above 1GHz, the above procedure is repeated using horn antennas and the difference between the gain of the horn and an isotropic or dipole antenna are taken into consideration.

6.1 Test Data (Continued)

6.5 CELLULAR CDMA Radiated Measurements

Field Strength of SPURIOUS Radiation

OPERATING FREQUENCY:	<u>824.70 MHz</u>
CHANNEL:	<u>1013 (Low)</u>
MEASURED OUTPUT POWER:	<u>25.113 dBm = 0.325 W</u>
MODULATION SIGNAL:	<u>CDMA (Internal)</u>
DISTANCE:	<u>3 meters</u>
LIMIT: $43 + 10 \log_{10} (W) =$	<u>38.11 dBc</u>

Freq. (MHz)	LEVEL (dBm)	POL (H / V)	(dBc)
1649.40	-68.50	H	54.5
2474.10	- 130		
3298.80	- 130		
4123.50	- 130		

NOTES:

Radiated Spurious Emission Measurements by Substitution Method according to ANSI/TIA/EIA-603 (rev.1998):

The EUT was placed on a wooden turn table 3-meters from the receive antenna. The receive antenna height and turntable rotation was adjusted for the highest reading on the receive spectrum analyzer. A half-wave dipole was substituted in place of the EUT. This dipole antenna was driven by a signal generator and the level of the signal generator was adjusted to obtain the same receive spectrum analyzer reading. This spurious level is recorded. For readings above 1GHz, the above procedure is repeated using horn antennas and the difference between the gain of the horn and an isotropic or dipole antenna are taken into consideration.

6.1 Test Data (Continued)

6.6 CELLULAR CDMA Radiated Measurements

Field Strength of SPURIOUS Radiation

OPERATING FREQUENCY:	<u>835.89 MHz</u>
CHANNEL:	<u>0363 (Mid)</u>
MEASURED OUTPUT POWER:	<u>25.113 dBm = 0.325 W</u>
MODULATION SIGNAL:	<u>CDMA (Internal)</u>
DISTANCE:	<u>3 meters</u>
LIMIT: $43 + 10 \log_{10} (W) =$	<u>38.11 dBc</u>

Freq. (MHz)	LEVEL (dBm)	POL (H / V)	(dBc)
1671.78	- 72.70	H	58.7
2507.67	- 130		
3343.56	- 130		
4179.45	- 130		

NOTES:

Radiated Spurious Emission Measurements by Substitution Method according to ANSI/TIA/EIA-603 (rev.1998):

The EUT was placed on a wooden turn table 3-meters from the receive antenna. The receive antenna height and turntable rotation was adjusted for the highest reading on the receive spectrum analyzer. A half-wave dipole was substituted in place of the EUT. This dipole antenna was driven by a signal generator and the level of the signal generator was adjusted to obtain the same receive spectrum analyzer reading. This spurious level is recorded. For readings above 1GHz, the above procedure is repeated using horn antennas and the difference between the gain of the horn and an isotropic or dipole antenna are taken into consideration.

6.1 Test Data (Continued)

6.7 CELLULAR CDMA Radiated Measurements

Field Strength of SPURIOUS Radiation

OPERATING FREQUENCY:	<u>848.31 MHz</u>
CHANNEL:	<u>0777 (High)</u>
MEASURED OUTPUT POWER:	<u>25.113 dBm = 0.325 W</u>
MODULATION SIGNAL:	<u>CDMA (Internal)</u>
DISTANCE:	<u>3 meters</u>
LIMIT: $43 + 10 \log_{10} (W) =$	<u>38.11dBc</u>

Freq. (MHz)	LEVEL (dBm)	POL (H / V)	(dBc)
1696.62	- 75.86	H	61.8
2544.93	- 130		
3393.24	- 130		
4241.55	- 130		

NOTES:

Radiated Spurious Emission Measurements by Substitution Method according to ANSI/TIA/EIA-603 (rev.1998):

The EUT was placed on a wooden turn table 3-meters from the receive antenna. The receive antenna height and turntable rotation was adjusted for the highest reading on the receive spectrum analyzer. A half-wave dipole was substituted in place of the EUT. This dipole antenna was driven by a signal generator and the level of the signal generator was adjusted to obtain the same receive spectrum analyzer reading. This spurious level is recorded. For readings above 1GHz, the above procedure is repeated using horn antennas and the difference between the gain of the horn and an isotropic or dipole antenna are taken into consideration.

7.1 Test Data

7.2 FREQUENCY STABILITY (AMPS)

OPERATING FREQUENCY: 836,490,237 Hz
 CHANNEL: 383
 REFERENCE VOLTAGE: 3.6 VDC
 DEVIATION LIMIT: ± 0.00025 % or 2.5 ppm

Voltage (%)	Power (VDC)	Temp. ()	Frequency (Hz)	Deviation (%)	Deviation (ppm)
100	3.6	+20 (Ref)	836,490,237	0.000000	0.00000
100		-30	836,489,743	0.000059	0.59056
100		-20	836,489,549	0.000082	0.82248
100		-10	836,489,730	0.000061	0.60610
100		0	836,489,654	0.000070	0.69696
100		+10	836,489,942	0.000035	0.35266
100		+20	836,489,754	0.000058	0.57741
100		+30	836,489,841	0.000047	0.47341
100		+40	836,489,435	0.000096	0.95877
100		+50	836,489,727	0.000061	0.60969
100		+60	836,489,425	0.000097	0.97072
85		3.06	+20	836,490,237	0.000000
115	4.14	+20	836,490,237	0.000000	0.00000
BATT.END POINT	2.92	+20	836,490,237	0.000000	0.00000

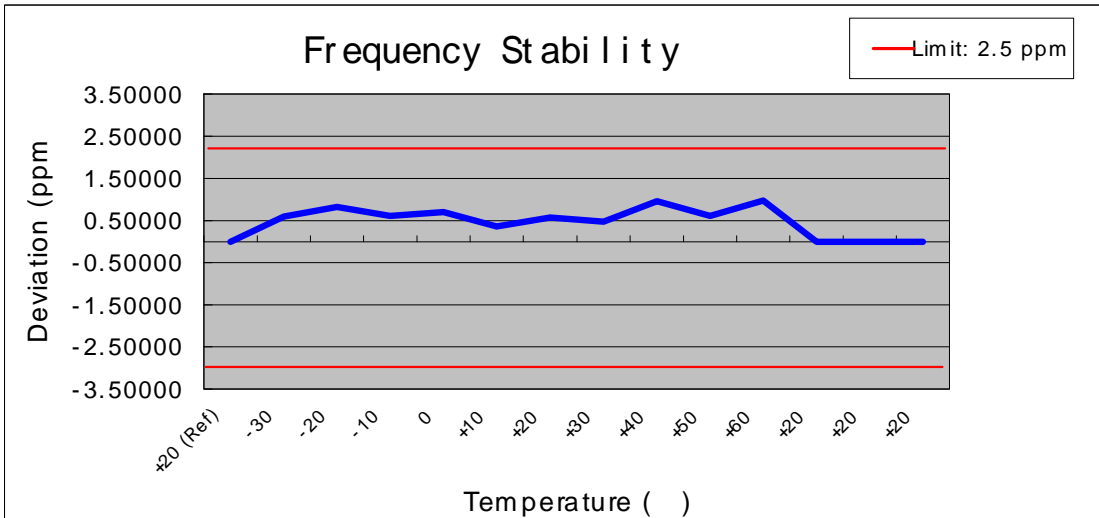

7.1 Test Data(Continued)

7.3 FREQUENCY STABILITY (CDMA)

OPERATING FREQUENCY: 835,890,124 Hz
 CHANNEL: 0363
 REFERENCE VOLTAGE: 3.6 VDC
 DEVIATION LIMIT: ± 0.00025 % or 2.5 ppm

Voltage (%)	Power (VDC)	Temp. ()	Frequency (Hz)	Deviation (%)	Deviation (ppm)
100	3.7	+20 (Ref)	1,880,000,124	0.000000	0.00000
100		-30	1,879,999,550	0.000031	0.30532
100		-20	1,879,999,445	0.000036	0.36117
100		-10	1,879,999,610	0.000027	0.27340
100		0	1,879,999,570	0.000029	0.29468
100		+10	1,880,000,170	-0.000002	-0.02447
100		+20	1,879,999,370	0.000040	0.40106
100		+30	1,879,999,542	0.000031	0.30957
100		+40	1,879,999,446	0.000036	0.36064
100		+50	1,879,999,571	0.000029	0.29415
100		+60	1,879,999,187	0.000050	0.49840
85		3.15	+20	1,880,000,124	0.000000
115	4.26	+20	1,880,000,124	0.000000	0.00000
BATT.END POINT	2.76	+20	1,880,000,124	0.000000	0.00000

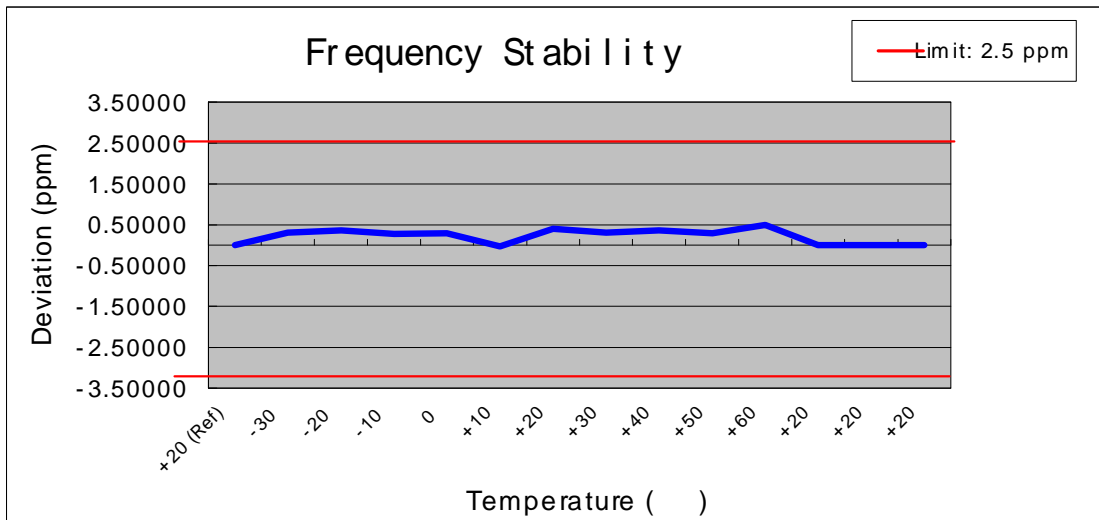

8.1 PLOT(S) OF EMISSION

(SEE ATTACHMENT D)

9.1 LIST OF TEST EQUIPMENT

Type / Model	Calib. Date	S/N
Spectrum Analyzer(20Hz~40GHz) R&S ESI40	Dec. 01	1088.7410
Spectrum Analyzer(30Hz~6.5GHz) HP 8561E	Oct. 01	3517A01161
Spectrum Analyzer(20Hz~40GHz) HP 8591A	Nov. 01	3131A02238
Signal Generator HP-8664A (100kHz ~ 3GHz)	Nov. 01	3744A01608
Signal Generator MARCONI(10kHz ~ 2.7GHz)	Sep. 01	119331
Power Meter(A) HP 438A	July 01	2822A05909
Power Sensor(A) HP8481B	July 01	3318A08777
Power Meter(B) HP 438A	Nov. 01	2427A00963
Power Sensor(B) HP8481A	Oct. 01	2349A37617
Power Amp A0825-4343-R	Sep. 01	A00450
Network Analyzer HP-8753D (30kHz ~ 3GHz)	Sep. 01	3401J02111
Modulation Analyzer HP8901A	June 01	3438A05231
Dipole Antenna UHAP	June 01	557
Dipole Antenna UHAP	June 01	558
Audio Analyzer HP 8903A	Feb.02	2433A04322
Function Generator HP 8116A	Feb.02	3001A08285
Horn Antenna BBHA 9120D	-	147/ 148
CDMA Mobile Station Test Set HP8924C	June 01	US39063847
PCS Interface HP83236B 1.7 ~ 2.0GHz	June 01	3711J04841
EMI Test Receiver Rohde & Schwarz ESH3	June 01	-
EMI Test Receiver Rohde & Schwarz ESVP	Feb. 02	-
EMI Test Receiver Rohde & Schwarz ESVS30	June 01	-
Graphic Plotter Rohde & Schwarz POP2	N.A	-
Printer Rohde & Schwarz PDN	N.A	-
Spectrum Analyzer H.P 8591EM	July 01	3509A00155
LISN EMCO 3825/2	July 01	9706-1070
LISN Rohde & Schwarz ESH2-Z5	July 01	9706-1071
Amplifier Hewlett-Packard 8447E	March 01	2805A03141
Biconical Antenna Rohde & Schwarz BBA-9106	June 01	D6901
Log-Periodic Antenna Rohde & Schwarz UHALP-9107	June 01	91071107
Antenna Position Tower EMCO 1051-12	N.A	-
Turn Table EMCO 1060-06	N.A	-
AC Power Source PACIFIC Magnetic Module	N.A	-
AC Power Source PACIFIC 360AMX	N.A	-

10.1 SAMPLE CALCULATIONS

Emission Designator per

Emission Designator = 1M25F9W

CDMA BW = 1.25 MHz

F = Frequency Modulation

9 = Composite Digital Info

W = Combination (Audio/Data)

(Measured at the 99.75% power bandwidth)

Emission Designator = 40K0F1D

Necessary Bandwidth:

Necessary Bandwidth (Bn), kHz = 40.0

(Measured at the 99.75% power bandwidth)

Emission Designator = 40K0F8W

Necessary Bandwidth:

Necessary Bandwidth (Bn), kHz = 40.0

(Measured at the 99.75% power bandwidth)

11.1 CONCLUSION

The data collected shows that the **Dual-Mode Cellular Phone (AMPS/CDMA) FCC ID: PP4DX-22B** complies with all the requirements of Parts 2 and 22 of the FCC rules.