

ANTENNA SPECIFICATION		DATE	05-16-2001	REV.	IR
MODEL	DX-20B	TYPE	Fixed Antenna	PAGE	1/19

APPROVAL SPECIFICATION	Prepared By	Reviewed By	Checked By	Approved By
	<i>[Signature]</i>	<i>[Signature]</i>	<i>[Signature]</i>	<i>[Signature]</i>
	5/16	5.18	5/18	5/18

TITLE	FIXED ANTENNA	Model	DX-20B	CUSTOMER	HYUNDAI
--------------	---------------	--------------	--------	-----------------	---------

DOCUMENT

NO.	CONTENTS	SHEETS
1	APPROVAL SPECIFICATION	1
2	ANTENNA SPECIFICATION	1

We want to approval the sumited product.

Apporved date : MAY. 16. 2001..

ANTENNA SPECIFICATION		DATE	05-16-2001	REV.	IR
MODEL	DX-20B	TYPE	Fixed Antenna	PAGE	2/19

ANTENNA SPECIFICATION

ANTENNA SPECIFICATION		DATE	05-16-2001	REV.	IR
MODEL	DX-20B	TYPE	Fixed Antenna	PAGE	3/19

- CONTENTS -

1. Revision LIST
2. Technical Items.
 - 2.1 Specification.
 - 2.2 Electrical Spec.
 - 2.3 Mechanical Spec.
 - 2.4 Packing Spec.
3. Test Equipment.
4. Electrical Demands.
 - 4.1 V.S.W.R.
 - 4.2 Radiation Pattern.
 - 4.3 Gain.
5. Mechanical Demands.
 - 5.1 Dimensions.
 - 5.2 Helix Tensile load Test
 - 5.3 Torque Test
 - 5.4 Helix deformation test
 - 5.5 Drop test.
6. Environmental demands.
 - 6.1 Temperature shock test
 - 6.2 Low Temperature Transportation/Storage Test
 - 6.3 High Temperature Transportation/Storage Test
 - 6.4 Temperature Change in High Humidity
- 7 Antenna drawing
- 8 Packing specification (drawing)

ANTENNA SPECIFICATION		DATE	05-16-2001	REV.	IR
MODEL	DX-20B	TYPE	Fixed Antenna	PAGE	4/19

1. REVISION LIST

REVISION LIST				
NO	DATE	CHANGE CONTENTS	CHANGE CAUSE	REV
1	2001. 5. 16	N/A	N/A	IR
2				
3				
4				
5				
6				
7				
8				
9				
10				
11				
12				
13				
14				
15				

ANTENNA SPECIFICATION		DATE	05-16-2001	REV.	IR
MODEL	DX-20B	TYPE	Fixed Antenna	PAGE	5/19

2. Technical Items

2.1 Specifications

2.1.1 Electrical Spec.

Electrical Spec.		
Frequency Range (MHz)	AMPS	
	TX	RX
	824-849	869-894
V.S.W.R (Max.)	2.0	2.0
GAIN (Min, in dBi)	-2.5dBi	-2.5dBi
Impedance(Nominal)	50 ohms	
Polarization	Vertical	
Radiation Pattern	Omni-Directional	
Maximum Power	2 Watts	

2.1.2 Mechanical Spec.

Mechanical Spec.	
Connector	Screw Type
Overall length	See drawing
Operating Temperature	-20°C ~ +70°C
Weight	2.3g

2.1.3 Packing Spec.

Packing Spec.		
PRODUCT	QUALITY	MATERIAL
TRAY	1×80EA	P.S
INNER BOX	1×2500EA	SW 2 type (A corrugated paper)
CARTON BOX	1×5000EA	DW 2 type (AB corrugated paper)

ANTENNA SPECIFICATION		DATE	05-16-2001	REV.	IR
MODEL	DX-20B	TYPE	Fixed Antenna	PAGE	6/19

3. Test Equipment

The equipment for antenna test are as follows.

- ◆ Network Analyzer to measure the V.S.W.R and impedance of antenna.
- ◆ Standard Horn Antenna that is adjustable in the AMPS band.
- ◆ Anechoic Chamber installed the cables, connectors and equipment for measurement.
- ◆ Digital Caliper to measure the dimensions.
- ◆ Torque Driver to measure the torque force of the helix.
- ◆ Climatic Chamber for environmental test.

ANTENNA SPECIFICATION		DATE	05-16-2001	REV.	IR
MODEL	DX-20B	TYPE	Fixed Antenna	PAGE	7/19

4. Electrical Demands

4.1 V.S.W.R

The V.S.W.R characteristics must satisfy the electrical demands. When the antenna is in the AMPS band, the V.S.W.R of Tx band must be less than 2.0:1 and the V.S.W.R of Rx band must be less than 2.0:1 in free space.

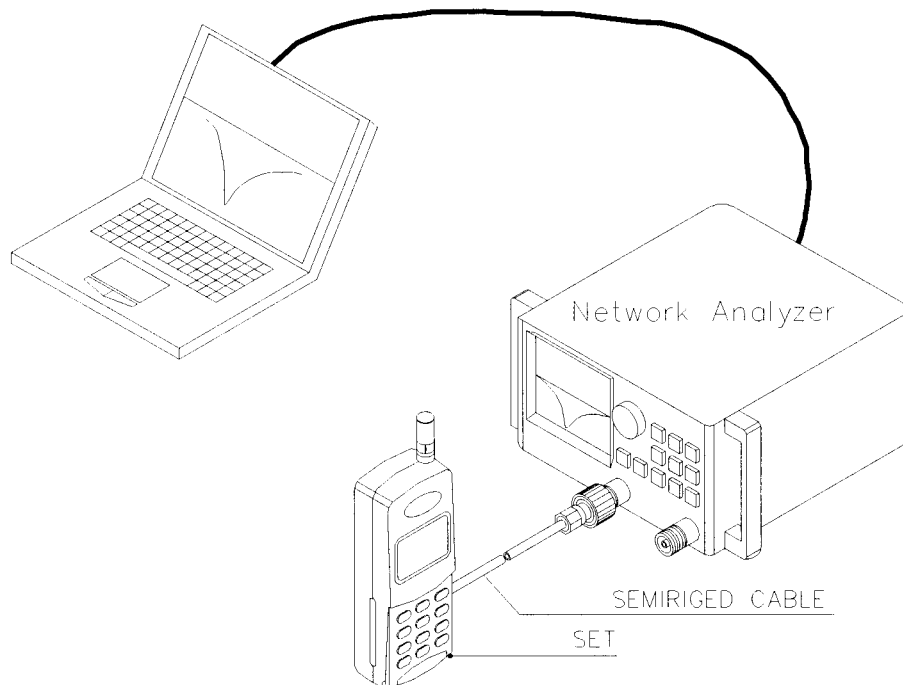

ANTENNA SPECIFICATION		DATE	05-16-2001	REV.	IR
MODEL	DX-20B	TYPE	Fixed Antenna	PAGE	8/19

4.2 Radiation Pattern

The radiation pattern must have the omni-directional characteristic in the fixed state.

4.3 Gain

The gain is expressed as dBi that standardizes the horn Antenna. When the antenna is in the AMPS band, The Gain of Tx band must greater than -2.5dBi and the Gain of Rx band must be greater than -2.5dBi .

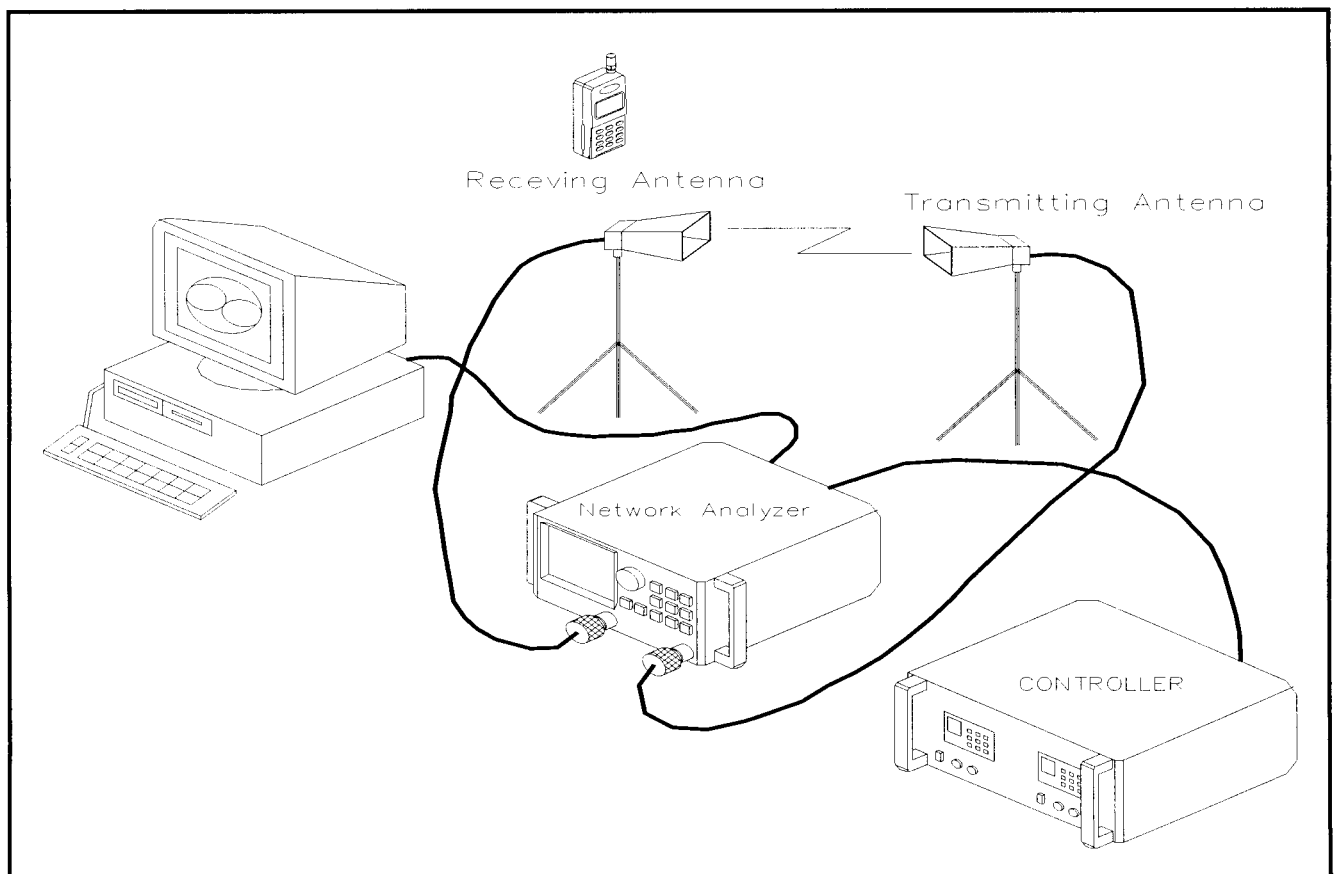

ANTENNA SPECIFICATION		DATE	05-16-2001	REV.	IR
MODEL	DX-20B	TYPE	Fixed Antenna	PAGE	9/19

5. Mechanical Demands

5.1 Dimensions.

See the drawing.

5.2 Helix tensile load test

Antenna is assembled to test equipment according to following figure.

The specified force 5Kgf applied during 30 second to the helix parallel to the antenna axis. Both electrical and mechanical performance will not be damaged after the test.

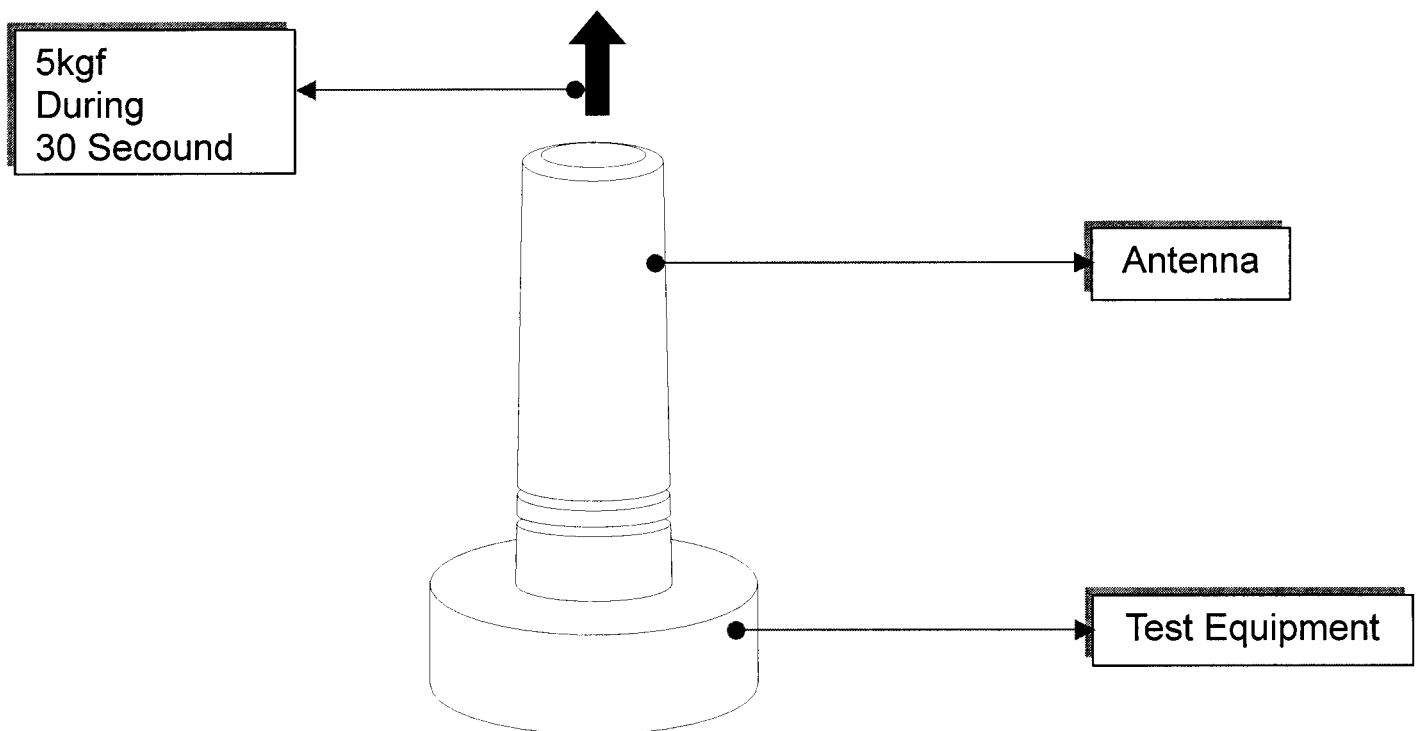

ANTENNA SPECIFICATION		DATE	05-16-2001	REV.	IR
MODEL	DX-20B	TYPE	Fixed Antenna	PAGE	10/19

5.3 Torque Test

The antenna is assembled to the test equipment. A 3Kgf·Cm force is applied to the antenna in clockwise direction. After the test, no visual deterioration shall occur and the part of the cover and the frame shall remain mechanically bonded. After the test, the antenna shall satisfy the electrical demands.

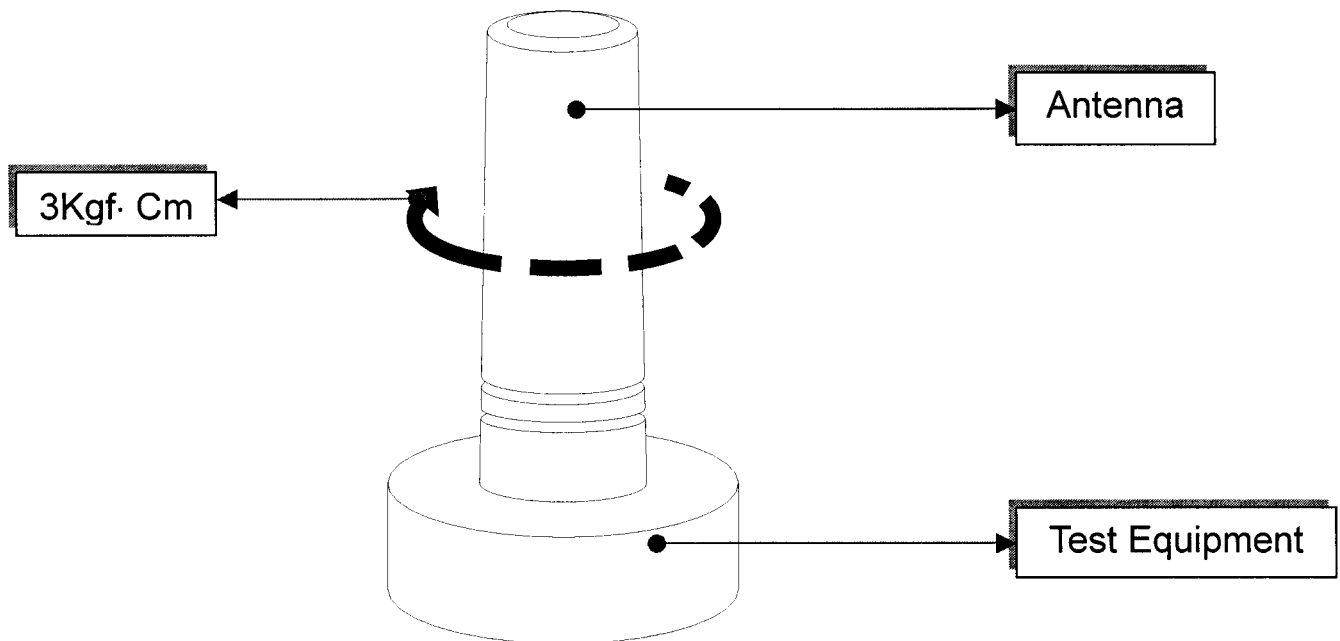

ANTENNA SPECIFICATION		DATE	05-16-2001	REV.	IR
MODEL	DX-20B	TYPE	Fixed Antenna	PAGE	11/19

5.4 Helix Deformation Test.

The antenna is assembled to the test equipment. A 4Kgf force is applied perpendicular and horizontal to the antenna 10 mm above the bottom of the HELIX. After the test, no visual deterioration shall occur and cover and frame shall remain mechanically bonded. After the test, the antenna shall satisfy the electrical demands.

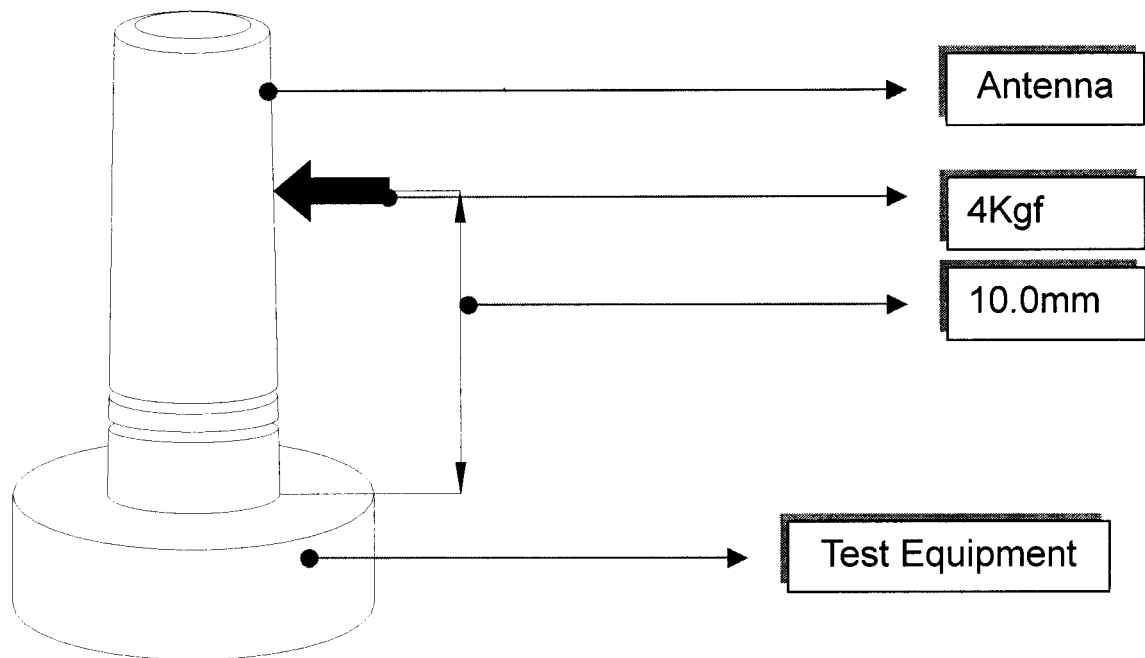

5.5 Drop test

The antenna is assembled to the handset with 100g. The handset is dropped with the antenna downward onto a concrete surface at 150Cm height. The number of drop is 2 times . After the test, the original shape shall be possible to restore. The antenna shall satisfy the electrical demands.

ANTENNA SPECIFICATION		DATE	05-16-2001	REV.	IR
MODEL	DX-20B	TYPE	Fixed Antenna	PAGE	12/19

6.Environmental Demands

6.1 Temperature Cycling Test

The object of temperature shock test is to evaluate the reliability of antenna component at fast temperature change.

- Initial measurements : The antenna shall be visually inspected and electrically and mechanically checked as required by DX-20B products standard.
- Test: Temperature cycle is as follows. 60 minutes at -20°C , 60 minutes at +85°C .
This procedure is repeated 10 times. Ending at +20°C and 50% RH

Post-processing : After testing, The antenna shall be remained in standard condition until the antenna has reached temperature stability state.

- Final measurements: The antenna shall be visually inspected and electrically and mechanically checked as required by DX-20B products standard.

ANTENNA SPECIFICATION		DATE	05-16-2001	REV.	IR
MODEL	DX-20B	TYPE	Fixed Antenna	PAGE	13/19

6.2 Low Temperature Transportation/Storage Test

The object of low temperature transportation/storage test is to conform the endurance of antenna component at low temperature in storage or transportation.

- Initial measurements : The antenna shall be visually inspected and electrically and mechanically checked as required by DX-20B products standard.
- Test: Temperature storage is as follows. Start at normal conditions, reach to -40°C .(velocity: $1^{\circ}\text{C}/\text{min}$) Duration : 3hours.
- post-processing : After testing, The antenna shall be remained in standard conditions until the antenna has reached temperature stability state.
- Final measurements : The antenna shall be visually inspected and also electrically and mechanically checked as required by DX-20B product standard.

Low Temperature Test

Duration : 3 Hours, Temperature : $-40(\text{C})$

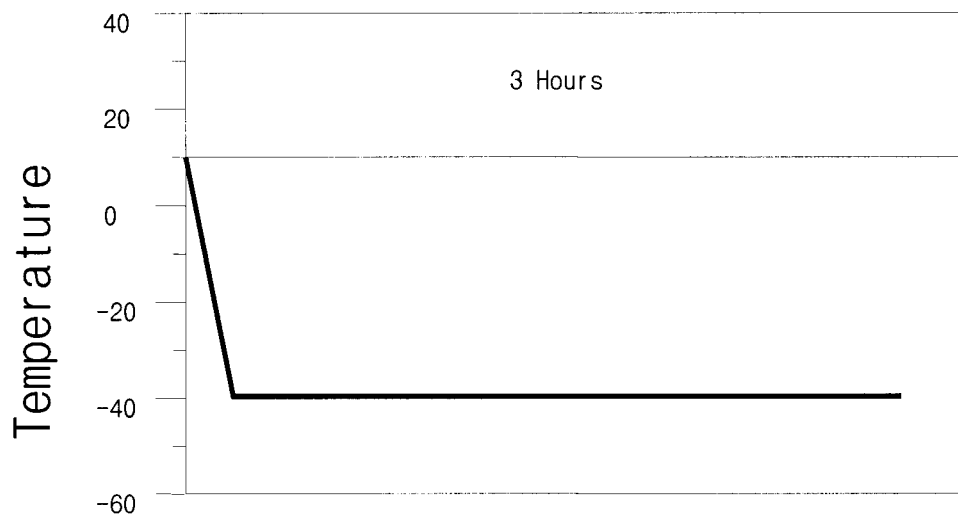

ANTENNA SPECIFICATION		DATE	05-16-2001	REV.	IR
MODEL	DX-20B	TYPE	Fixed Antenna	PAGE	14/19

6.3 High Temperature Transportation/Storage Test

The object of High Temperature Transportation/Storage Test is to conform the endurance of antenna component at low temperature in storage or transportation.

- Initial measurements : The antenna shall be visually inspected and electrically and mechanically checked as required by DX-20B products standard.
- Test: Temperature storage is as follows. Start at normal conditions, reach to +85°C velocity.(1°C/min) Duration: 3hours.
- post-processing : After testing, The antenna shall be remained in standard conditions until the antenna reach stability.
- Final measurements : The antenna shall be visually inspected and also electrically and mechanically checked as required by DX-20B product standard.

High Temperature Test

Duration : 3 Hours, Temperature : +85(C)

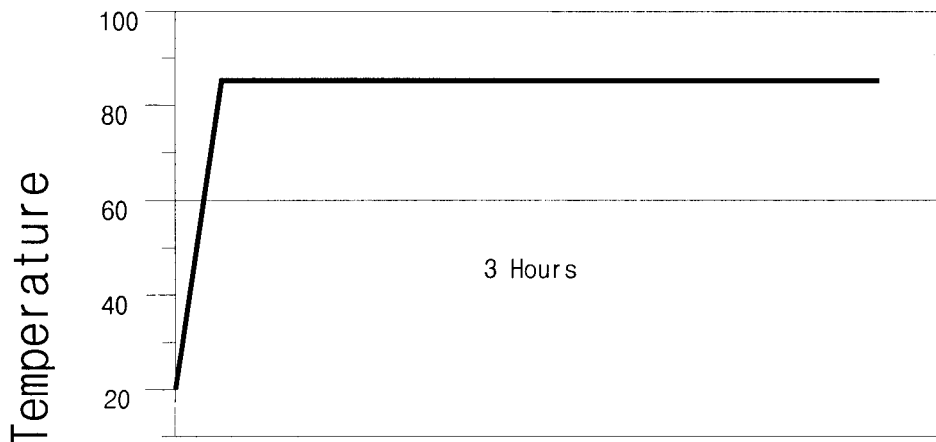

ANTENNA SPECIFICATION		DATE	05-16-2001	REV.	IR
MODEL	DX-20B	TYPE	Fixed Antenna	PAGE	15/19

6.4 Temperature Change in High Humidity

- Initial measurements : The antenna shall be visually inspected and electrically and mechanically checked as required by DX-20B products standard.
- Test: Temperature cycle is as follows. Start at +25°C, reach +55°C within 1hours. 3hours at +55°C, decrease +25°C within 1hours and 3hours at +25°C. Relative humidity is 95%.
- Post-processing : After testing, The antenna shall remain in standard conditions until taking stable conditions.
- Final measurements : The antenna shall be visually inspected and electrically and also mechanically checked as required by DX-20B products standard.

Temperature Change in High Humidity

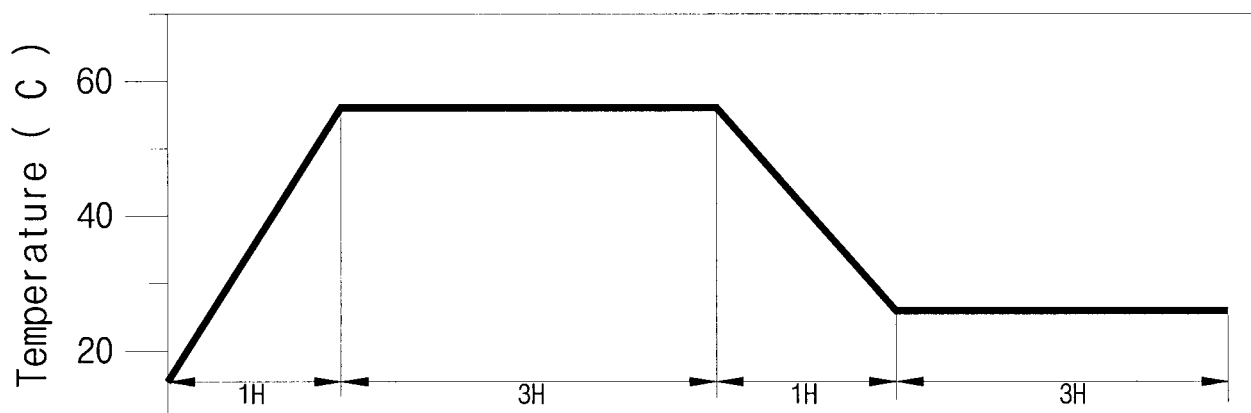

ANTENNA SPECIFICATION		DATE	05-16-2001	REV.	IR
MODEL	DX-20B	TYPE	Fixed Antenna	PAGE	16/19

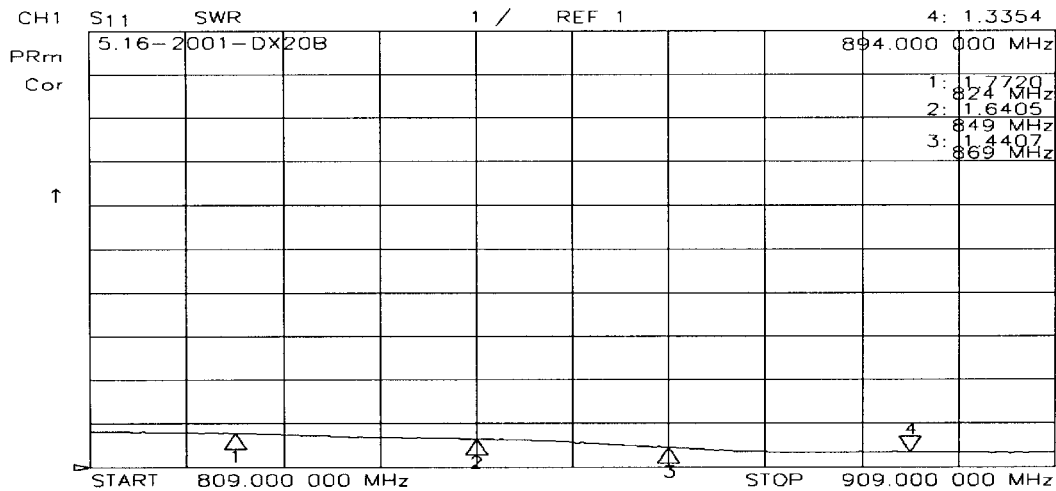

UnClassified

Beam Peak = -1.70 dBi, 105.00 deg
 Beam Peak = -1.69 dBi, -101.00 deg
 Beam Peak = -1.61 dBi, 105.00 deg
 Beam Peak = -1.05 dBi, 106.00 deg

▼ Frequency = 0.824 (GHz)
 ▽ Frequency = 0.849 (GHz)
 ▲ Frequency = 0.869 (GHz)
 △ Frequency = 0.894 (GHz)

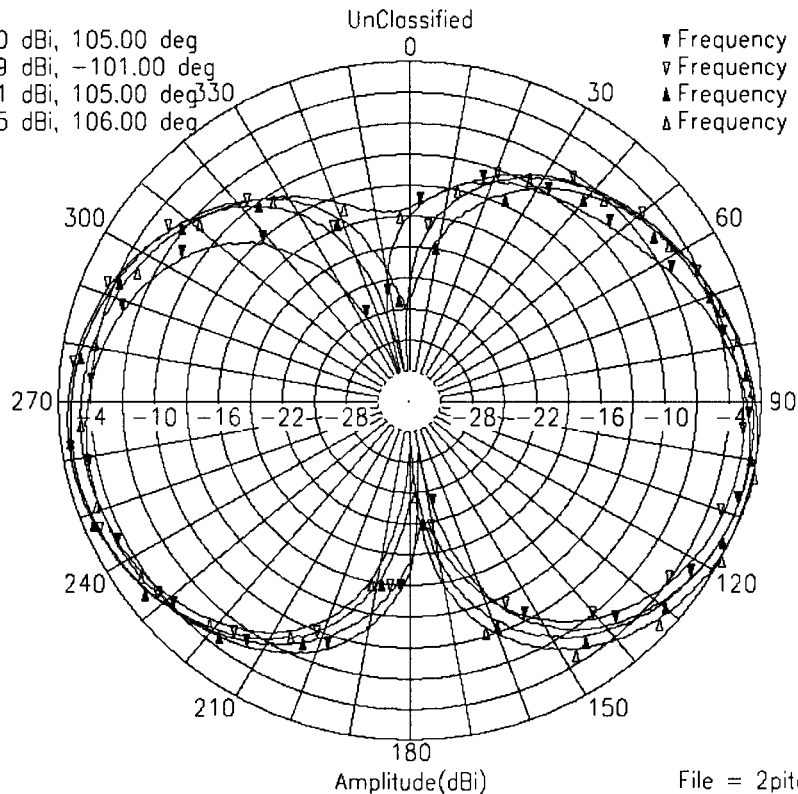

ANTENNA SPECIFICATION		DATE	05-16-2001	REV.	IR
MODEL	DX-20B	TYPE	Fixed Antenna	PAGE	17/19

Beam Peak = -2.19 dBi, 108.00 deg
 Beam Peak = -1.67 dBi, -94.00 deg
 Beam Peak = -1.23 dBi, 103.00 deg
 Beam Peak = -1.17 dBi, 109.00 deg

▼ Frequency = 0.824 (GHz)
 ▽ Frequency = 0.849 (GHz)
 ▲ Frequency = 0.869 (GHz)
 △ Frequency = 0.894 (GHz)

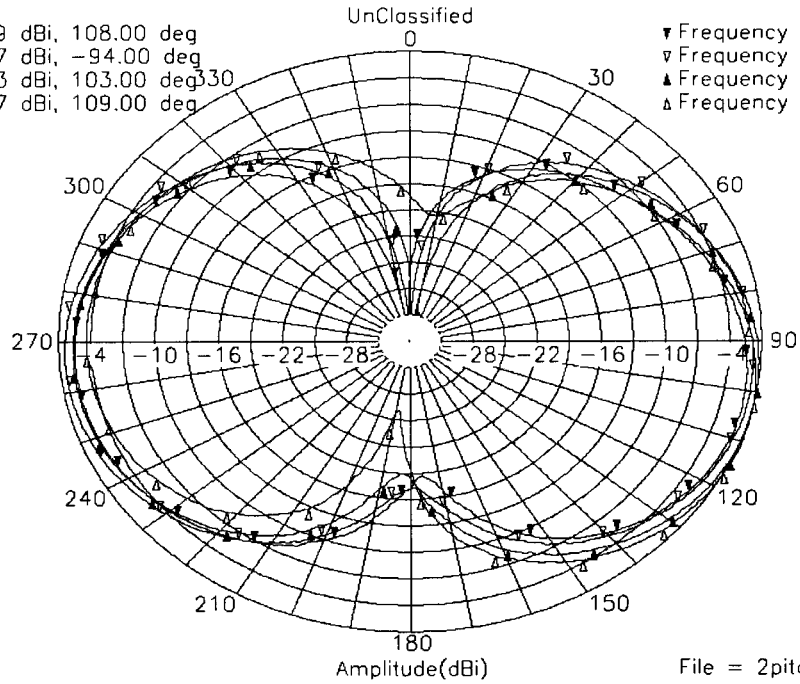

Beam Peak = -2.00 dBi, 52.00 deg
 Beam Peak = 0.35 dBi, -124.00 deg
 Beam Peak = 0.35 dBi, -121.00 deg
 Beam Peak = 0.02 dBi, -124.00 deg

▼ Frequency = 0.824 (GHz)
 ▽ Frequency = 0.849 (GHz)
 ▲ Frequency = 0.869 (GHz)
 △ Frequency = 0.894 (GHz)

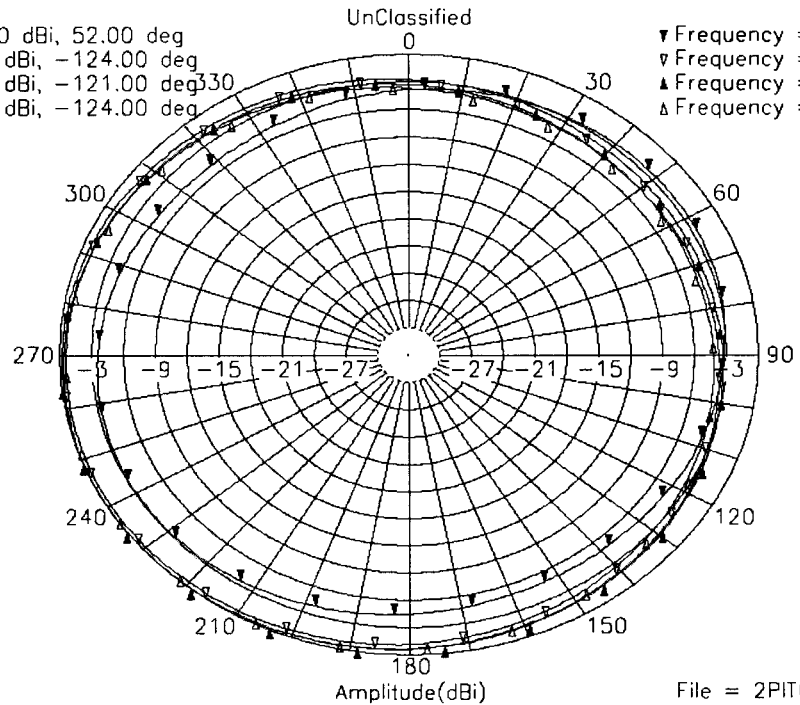

ANTENNA SPECIFICATION		DATE	05-16-2001	REV.	IR
MODEL	DX-20B	TYPE	Fixed Antenna	PAGE	18/19

7. Antenna drawing

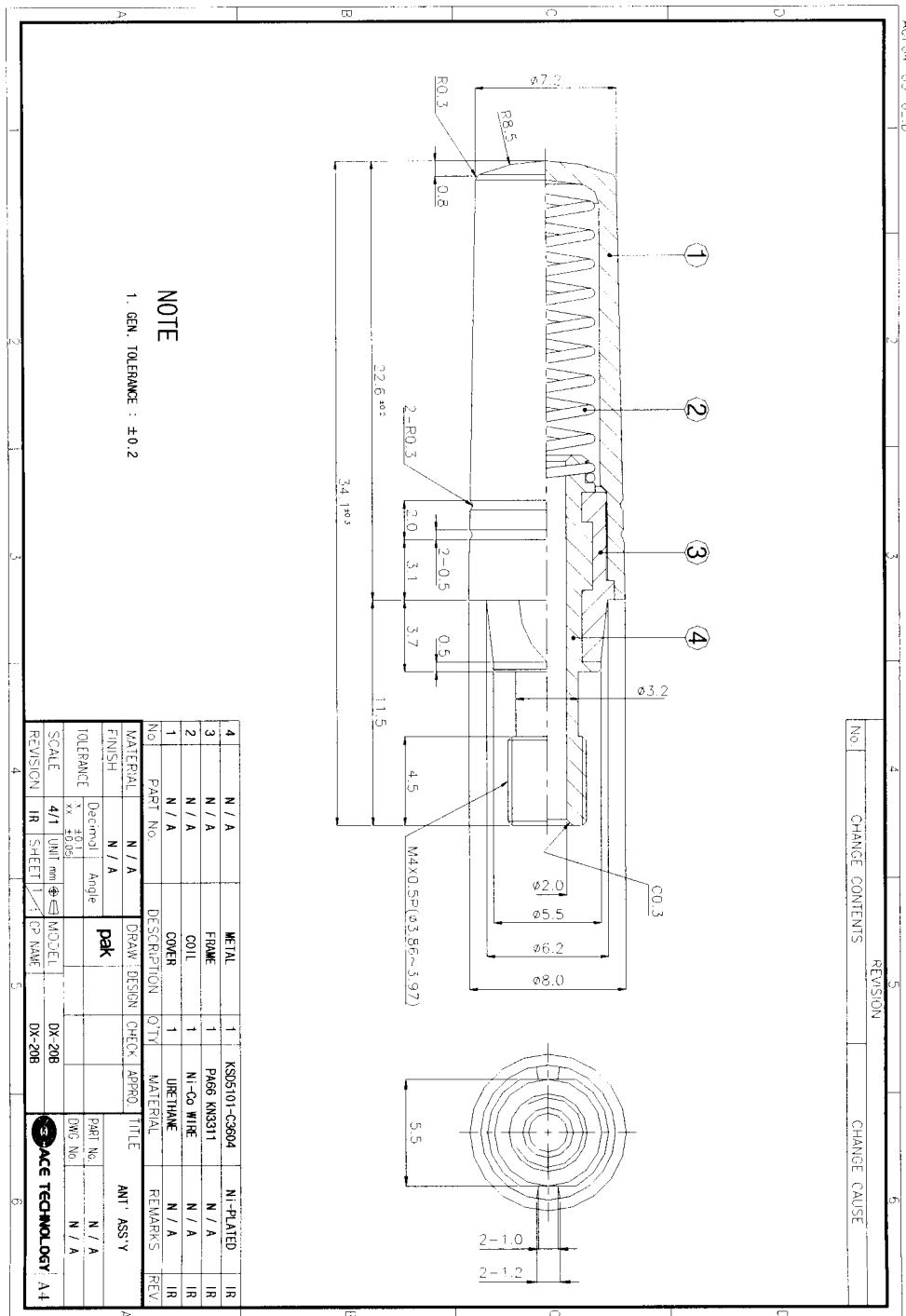

ANTENNA SPECIFICATION		DATE	05-16-2001	REV.	IR
MODEL	DX-20B	TYPE	Fixed Antenna	PAGE	19/19

8. Packing specification(drawing)

