

**FCC ID PER PART 15.227  
EMI MEASUREMENT AND TEST REPORT**

For

**MLK Technologies Limited**

1019-1020, Nam Fung Center, Tsuen Wan,  
264-298 Castle Peak Road, N.T. Hong Kong

<b>FCC ID: PP2MLKF-2000</b>
-----------------------------

July 9, 2001

<b>This Report Concerns:</b> <input checked="" type="checkbox"/> Original Report	<b>Equipment Type:</b> Cordless Keyboard, ITE
<b>Test Engineer:</b> <u>Jeff Lee</u>	
<b>Test Date:</b> <u>June 22, 2001</u>	
<b>Reviewed By:</b> <u>John Y. Chan – Engineering Manager</u>	
<b>Prepared By:</b> Bay Area Compliance Laboratory Corporation 230 Commercial Street, Suite 2 Sunnyvale, CA 94085 Tel: (408) 732-9162 Fax: (408) 732-9164	

**Note:** This report may not be duplicated without prior written consent of Bay Area Compliance Laboratory Corporation. This report **must not** be used by the client to claim product endorsement by NVLAP or any agency of the U.S. Government.

**TABLE OF CONTENTS**

**1 - GENERAL INFORMATION..... 3**

1.1 PRODUCT DESCRIPTION FOR EQUIPMENT UNDER TEST (EUT) .....3

1.2 OBJECTIVE .....3

1.3 RELATED SUBMITTAL(S)/GRANT(S).....3

1.4 TEST METHODOLOGY.....3

1.5 TEST FACILITY .....3

1.6 TEST EQUIPMENT LIST .....4

1.7 EQUIPMENT UNDER TEST (EUT).....4

1.8 HOST SYSTEM CONFIGURATION.....4

1.9 LOCAL SUPPORT EQUIPMENT LIST AND DETAILS.....5

1.10 EXTERNAL I/O CABLES LIST AND DETAILS.....5

**2 - SYSTEM TEST CONFIGURATION..... 6**

2.1 JUSTIFICATION.....6

2.2 SCHEMATICS AND BLOCK DIAGRAM.....6

2.3 EQUIPMENT MODIFICATIONS.....6

2.4 TEST SETUP CONFIGURATION.....7

2.5 TEST SETUP BLOCK DIAGRAM.....8

**3 – SUMMARY OF TEST RESULTS ..... 9**

**4 - RADIATED EMISSION DATA..... 10**

4.1 EUT SETUP .....10

4.2 SPECTRUM ANALYZER SETUP.....10

4.3 TEST PROCEDURE .....10

4.4 CORRECTED AMPLITUDE & MARGIN CALCULATION.....11

4.5 SUMMARY OF TEST RESULTS.....11

4.6 RADIATED EMISSIONS TEST RESULT DATA.....11

---

## 1 - GENERAL INFORMATION

---

### 1.1 Product Description for Equipment Under Test (EUT)

The *MLK Technologies Limited*'s product, model *MLKF-2000* or the "EUT" as referred to in this report is a wireless keyboard which measures approximately 18.5" L x 7.5" W x 1.5" H.

### 1.2 Objective

This Type approval report is prepared on behalf of *MLK Technologies Limited* in accordance with Part 2, Subpart J, and Part 15, Subparts A and B of the Federal Communication Commissions rules.

The objective of the manufacturer is to demonstrate compliance with FCC rules, Part 15, sec 227 for radiated margin.

### 1.3 Related Submittal(s)/Grant(s)

No Related Submittals.

### 1.4 Test Methodology

All measurements contained in this report were conducted with ANSI C63.4 –1992, American National Standard for Methods of Measurement of Radio-Noise Emissions from Low-Voltage Electrical and Electronic Equipment in the range of 9 kHz to 40 GHz. All radiated and conducted emissions measurement was performed at Bay Area Compliance Laboratory, Corp. The radiated testing was performed at an antenna-to-EUT distance of 3 meters.

### 1.5 Test Facility

The Open Area Test site used by Bay Area Compliance Laboratory Corporation to collect radiated and conducted emission measurement data is located in the back parking lot of the building at 230 Commercial Street, Suite 2, Sunnyvale, California, USA.

Test site at Bay Area Compliance Laboratory Corporation has been fully described in reports submitted to the Federal Communication Commission (FCC) and Voluntary Control Council for Interference (VCCI). The details of these reports has been found to be in compliance with the requirements of Section 2.948 of the FCC Rules on February 11 and December 10, 1997 and Article 8 of the VCCI regulations on December 25, 1997. The facility also complies with the radiated and AC line conducted test site criteria set forth in ANSI C63.4-1992.

The Federal Communications Commission and Voluntary Control Council for Interference has the reports on file and is listed under FCC file 31040/SIT 1300F2 and VCCI Registration No.: C-1298 and R-1234. The test site has been approved by the FCC and VCCI for public use and is listed in the FCC Public Access Link (PAL) database.

Additionally, Bay Area Compliance Laboratory Corporation is a National Institute of Standards and Technology (NIST) accredited laboratory, under the National Voluntary Laboratory Accredited Program (NVLAP). The scope of the accreditation covers the FCC Method - 47 CFR Part 15 - Digital Devices, IEC/CISPR 22: 1998, and AS/NZS 3548: Electromagnetic Interference - Limits and Methods of Measurement of Information Technology Equipment test methods under NVLAP Lab Code 200167-0.

### 1.6 Test Equipment List

Manufacturer	Description	Model	Serial Number	Cal. Due Date
HP	Spectrum Analyzer	8568B	2610A02165	12/6/01
HP	Spectrum Analyzer	8593B	2919A00242	12/20/01
HP	Amplifier	8349B	2644A02662	12/20/01
HP	Quasi-Peak Adapter	85650A	917059	12/6/01
HP	Amplifier	8447E	1937A01046	12/6/01
A.H. System	Horn Antenna	SAS0200/571	261	12/27/01
Com-Power	Log Periodic Antenna	AL-100	16005	11/2/01
Com-Power	Biconical Antenna	AB-100	14012	11/2/01
Solar Electronics	LISN	8012-50-R-24-BNC	968447	12/28/01
Com-Power	LISN	LI-200	12208	12/20/01
Com-Power	LISN	LI-200	12005	12/20/01
BACL	Data Entry Software	DES1	0001	12/20/01

### 1.7 Equipment Under Test (EUT)

Manufacturer	Description	Model	Serial Number	FCC ID
MLK Technologies Limited	Wireless Keyboard	MLKF-2000	None	PP2MLKF-2000

### 1.8 Host System Configuration

Manufacturer	Description	Model	Serial Number	FCC ID
TYAN	Motherboard	S2462	None	DOC
NEC	Floppy Drive	FD123H	DA1M99UK1501	DOC
FUJITSU	Hard Drive	MPG3102AT	VH34POB00DRO	JWYEIP
DELTA	Power Supply	DpS-465AB A	CLT0046000373	DOC
IBM	Chassis	N/A	None	None
A Open	CD-ROM	CD-936E/AKU	8330742BKNC	DOC

**1.9 Local Support Equipment List and Details**

<b>Manufacturer</b>	<b>Description</b>	<b>Model</b>	<b>Serial Number</b>	<b>FCC ID</b>
Citizen	Printer	LSP-10	5047999-82	DLK66TLSP-10
Compaq	Mouse	M-S34	B04AB0H5BF844RG	DOC
EVEREX	Modem	EV-945	None	E3E5UVEV-945
Gateway	Monitor	E7006	MIA8J8429859	IAWE 7006
IBM	PC System	520	AM707AR	DOC

**1.10 External I/O Cables List and Details**

<b>Description</b>	<b>Length (M)</b>	<b>From</b>	<b>To</b>
Shielded Serial Cable	1.5	Serial Port/Host PC	Modem
Shielded Mouse Cable	1.5	PS/2 Mouse Port/Host PC	Mouse
Shielded Printer Cable	2.0	Parallel Port/Host PC	Printer
Shielded Video	1.8	VGA Port/Host PC	Monitor
Shielded USB Port	1.5	USB Port/Host PC	Receiver

---

## **2 - SYSTEM TEST CONFIGURATION**

---

### **2.1 Justification**

The EUT was configured for testing in a typical fashion (as normally used in a typical application).

The final qualification test was performed with the EUT operating at normal mode.

### **2.2 Schematics and Block Diagram**

Appendix B contains a copy of schematics and block diagram as reference.

### **2.3 Equipment Modifications**

No modifications were necessary for the EUT to comply.

### 2.4 Test Setup Configuration

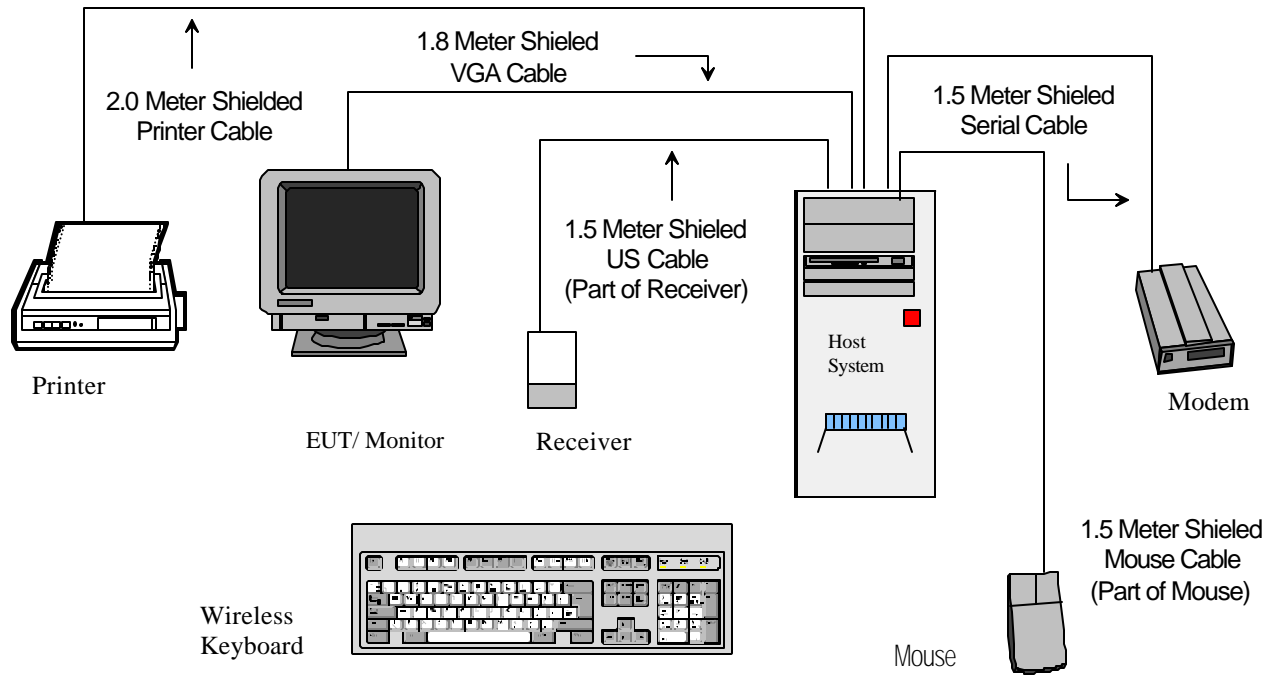

### 2.5 Test Setup Block Diagram

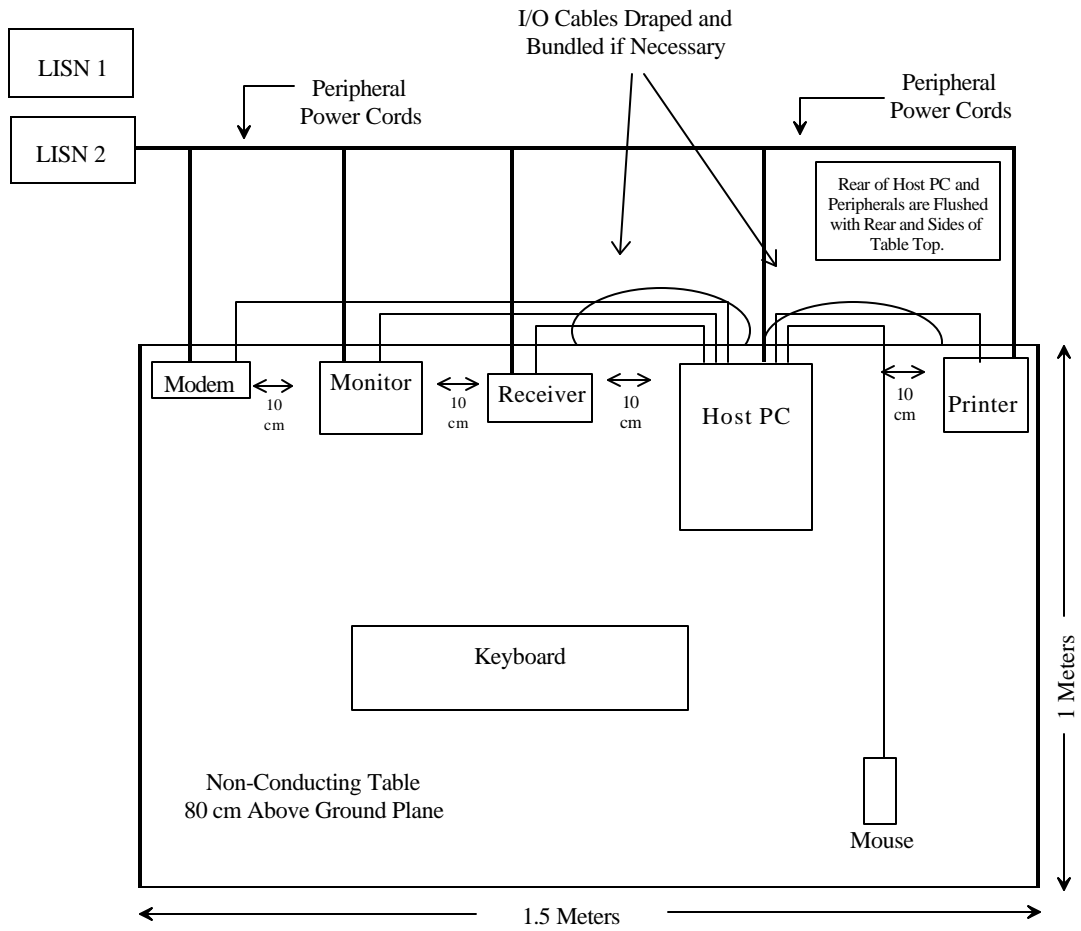



---

**3 – SUMMARY OF TEST RESULTS**

---

<b>FCC RULES</b>	<b>DESCRIPTION OF TEST</b>	<b>RESULT</b>
§ 15.207	Conducted Emission	Not Applicable because of Battery Operation
§ 15.227 and § 15.209	Radiated Emission	Pass

## 4 - RADIATED EMISSION DATA

### 4.1 EUT Setup

The radiated emission tests were performed in the open area 3-meter test site, using the setup accordance with the ANSI C63.4 - 1992. The specification used was the FCC Class B limits.

The host PC was placed on the center back edge of the test table. The monitor and the modem were on the one side in sequence and the printer was on the other side. The rear of all peripherals was flushed with the rear of the test table.

The EUT was placed on the front edge of test table and in front of host PC and monitor. The mouse was next to the keyboard. The rear of the mouse was flushed with the rear of the test table with other peripherals.

The spacing between the peripherals was 10 cm.

External I/O cables are draped over edge of test table or bundled when necessary.

The host PC was connected to a 110 Vac/60 Hz power source.

### 4.2 Spectrum Analyzer Setup

According to FCC Rules, 47 CFR 15.33, the EUT was tested to 1000 MHz.

During the radiated emission test, the spectrum analyzer was set with the following configurations:

Start Frequency .....	30 MHz
Stop Frequency .....	1000 MHz
Sweep Speed .....	Auto
IF Bandwidth.....	100 kHz
Video Bandwidth.....	1 MHz
Quasi-Peak Adapter Bandwidth.....	120 kHz
Quasi-Peak Adapter Mode .....	Normal
Resolution Bandwidth.....	1MHz

### 4.3 Test Procedure

Maximizing procedure was performed on the six (6) highest emissions to ensure EUT is compliant with all installation combination.

All data was recorded in the peak detection mode. Quasi-peak readings performed only when an emission was found to be marginal (within -4 dB $\mu$ V of specification limitation), and are distinguished with a "QP" in the data table.

The EUT was operating at normal to represent worst case during final qualification test. Therefore, this configuration was used for final test data recorded in the table(s) listed under section 4.7 of this report.

#### 4.4 Corrected Amplitude & Margin Calculation

The Corrected Amplitude is calculated by adding the Antenna Factor and Cable Factor, and subtracting the Amplifier Gain from the Amplitude reading. The basic equation is as follows:

$$\text{Corr. Ampl.} = \text{Indicated Reading} + \text{Antenna Factor} + \text{Cable Factor} - \text{Amplifier Gain}$$

The “**Margin**” column of the following data tables indicates the degree of compliance with the applicable limit. For example, a margin of  $-7\text{dB}\mu\text{V}$  means the emission is  $7\text{dB}\mu\text{V}$  below the maximum limit for Class B. The equation for margin calculation is as follows:

$$\text{Margin} = \text{Corr. Ampl.} - \text{FCC Limit}$$

#### 4.5 Summary of Test Results

According to the final data in section 4.6, the EUT complied with the FCC 15.227 and FCC 15.209 standards, and had the worst margin of:

**-1.5 dBmV at 40.62 MHz in the Vertical polarization for Normal operating mode,  
30 to 1000 MHz, 3 meters.**

#### 4.6 Radiated Emissions Test Result Data

INDICATED		TABLE Angle	ANTENNA		CORRECTION FACTOR			CORRECTED AMPLITUDE Corr. Ampl.	FCC 15.227 & 15.209	
Frequency MHz	Ampl. dBmV/m		Height Meter	Polar H/ V	Antenna dBmV/m	Cable dB	Amp. dB		Limit dBmV/m	Margin dB
40.62	46.4	135	1.0	V	12.3	1.4	21.6	38.5	40.0	-1.5
297.85	34.9	315	1.0	H	19.4	5.3	22.6	37.0	46.0	-9.0
270.00	35.2	45	1.8	H	18.9	4.9	22.2	36.8	46.0	-9.2
135.40	34.6	90	1.0	V	11.1	3.1	21.2	27.6	43.5	-15.9
311.38	33.8	225	1.0	H	13.2	5.4	23.0	29.4	46.0	-16.6
148.93	33.0	270	1.0	V	11.4	3.2	21.4	26.2	43.5	-17.3
324.92	30.9	180	1.0	H	13.2	5.6	22.7	27.0	46.0	-19.0
54.19	30.6	270	1.0	V	10.2	1.7	21.7	20.8	40.0	-19.2
338.48	29.7	315	1.0	H	13.7	5.7	22.6	26.5	46.0	-19.5
352.05	29.2	180	1.0	H	14.0	6.0	23.0	26.2	46.0	-19.8
121.86	29.8	270	1.0	V	11.1	3.0	21.5	22.4	43.5	-21.1
108.32	29.4	90	1.2	V	9.2	2.7	21.6	19.7	43.5	-23.8
* 27.08	56.3	225	1.0	V	15.3	0.3	22.0	49.9	80.0	-30.1
*27.08	53.5	225	1.2	H	15.3	0.3	22.0	47.1	80.0	-32.9

\* Fundamental Frequency of EUT