

R10	R11	SENSOR
	200K	0
	200K	90
	200K	180
	200K	270

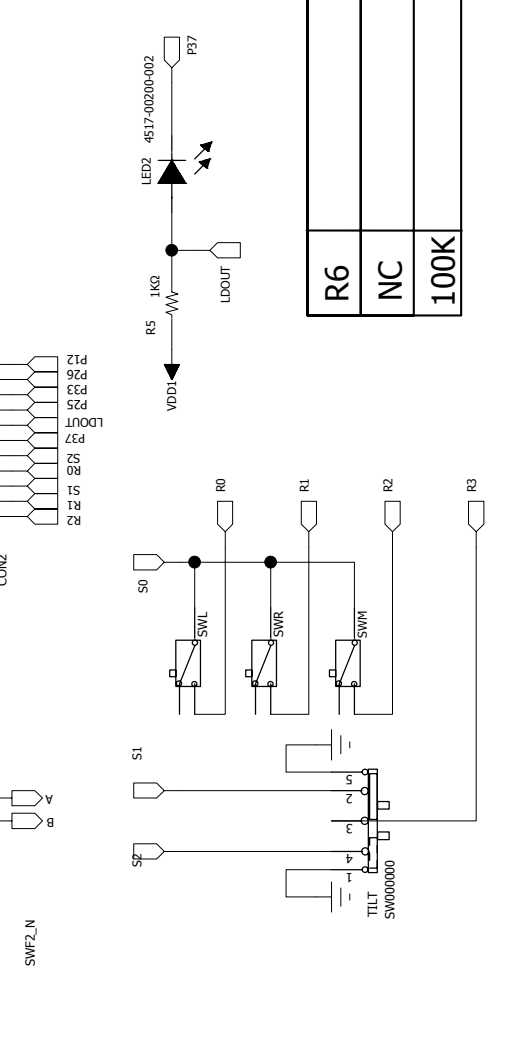
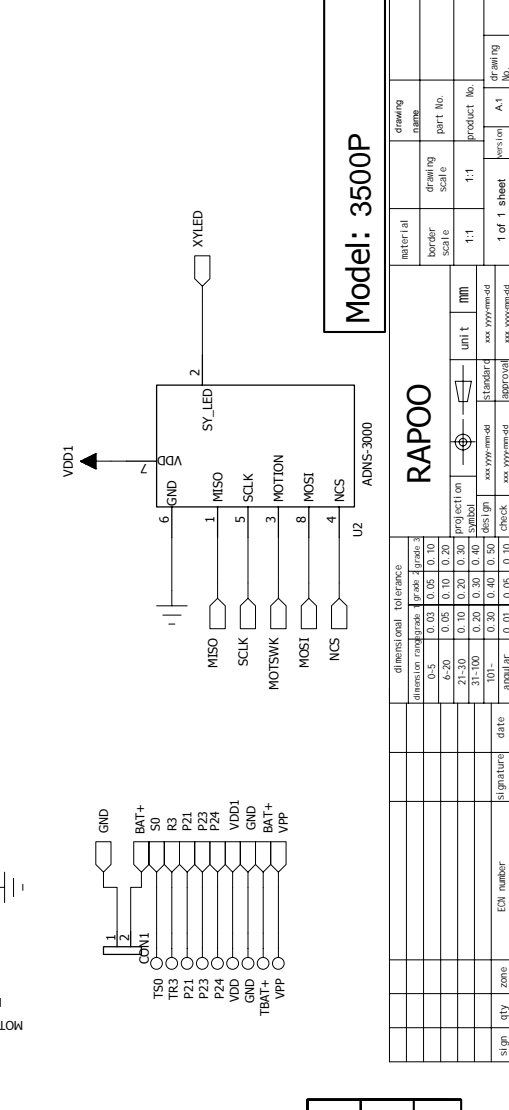
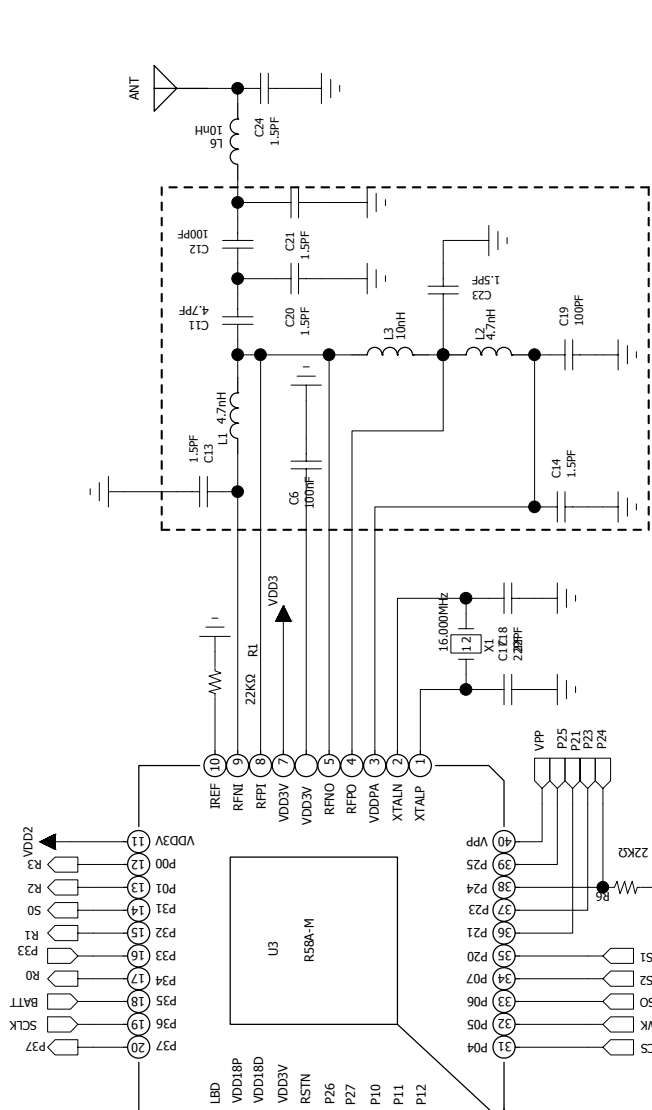
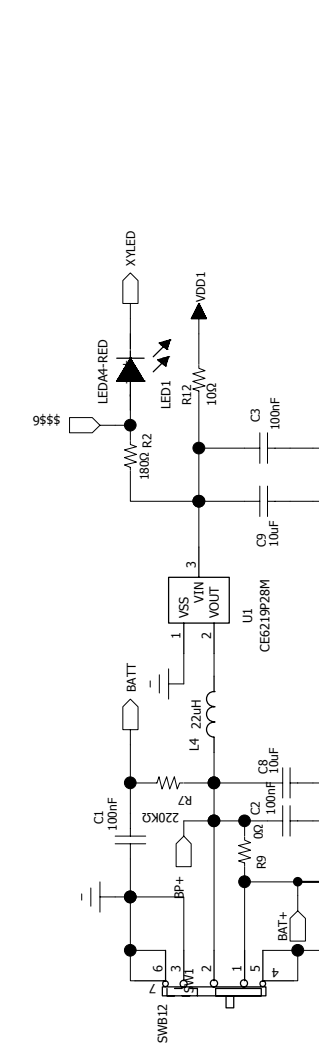
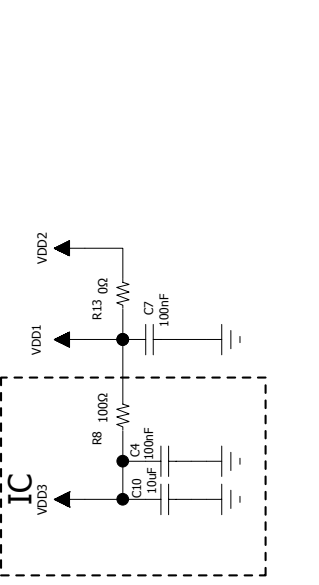

Model: 3500P

drawing name	drawing scale	part No.	product No.	sheet No.	total sheet
RAPOO	1:1	1:1	1:1	1 of 1	1 of 1
material	border	scale	unit	standard	approval
			mm	xxx xxxxxxxx	xxx xxxxxxxx
dimension	tolerance	tolerance	date	signature	date
dimension	tolerance	tolerance			
0-5	0.05	0.10			
6-20	0.05	0.10			
21-30	0.10	0.20			
31-100	0.20	0.30			
101-	0.30	0.40			
angular	0.01	0.05			

R6	NC	100K
----	----	------

signature	date	signature	date