

---

# FCC Test Report

---

Report No.: AGC00569220202FE02

**FCC ID** : PP22989  
**APPLICATION PURPOSE** : Original Equipment  
**PRODUCT DESIGNATION** : 2.4G keyboard  
**BRAND NAME** : RAPOO  
**MODEL NAME** : E1050, K800, K260S, K8200P, K1800Plus, K1800Pro  
**APPLICANT** : ShenZhen Rapoo Technology Co., Ltd.  
**DATE OF ISSUE** : Mar. 05, 2022  
**STANDARD(S)** : FCC Part 15.247  
**REPORT VERSION** : V1.0

Attestation of Global Compliance (Shenzhen) Co., Ltd



**REPORT REVISE RECORD**

<b>Report Version</b>	<b>Revise Time</b>	<b>Issued Date</b>	<b>Valid Version</b>	<b>Notes</b>
V1.0	/	Mar. 05, 2022	Valid	Initial Release

**TABLE OF CONTENTS**

**1. VERIFICATION OF COMPLIANCE..... 5**

**2. GENERAL INFORMATION ..... 6**

2.1. PRODUCT DESCRIPTION ..... 6

2.2. TABLE OF CARRIER FREQUENCYS ..... 7

2.3. RELATED SUBMITTAL(S)/GRANT(S)..... 8

2.4. TEST METHODOLOGY ..... 8

2.5. SPECIAL ACCESSORIES..... 8

2.6. EQUIPMENT MODIFICATIONS..... 8

2.7. ANTENNA REQUIREMENT ..... 8

**3. MEASUREMENT UNCERTAINTY ..... 9**

**4. DESCRIPTION OF TEST MODES ..... 10**

**5. SYSTEM TEST CONFIGURATION ..... 11**

5.1. CONFIGURATION OF TESTED SYSTEM..... 11

5.2. EQUIPMENT USED IN TESTED SYSTEM ..... 11

5.3. SUMMARY OF TEST RESULTS..... 11

**6. TEST FACILITY ..... 12**

**7. PEAK OUTPUT POWER..... 13**

7.1. MEASUREMENT PROCEDURE..... 13

7.2. TEST SET-UP (BLOCK DIAGRAM OF CONFIGURATION) ..... 13

7.3. LIMITS AND MEASUREMENT RESULT..... 14

**8. BANDWIDTH ..... 16**

8.1. MEASUREMENT PROCEDURE..... 16

8.2. TEST SET-UP (BLOCK DIAGRAM OF CONFIGURATION) ..... 16

8.3. LIMITS AND MEASUREMENT RESULTS ..... 16

**9. CONDUCTED SPURIOUS EMISSION..... 20**

9.1. MEASUREMENT PROCEDURE..... 20

9.2. TEST SET-UP (BLOCK DIAGRAM OF CONFIGURATION) ..... 20

9.3. MEASUREMENT EQUIPMENT USED ..... 20

9.4. LIMITS AND MEASUREMENT RESULT..... 20

**10. MAXIMUM CONDUCTED OUTPUT POWER SPECTRAL DENSITY ..... 27**

10.1. MEASUREMENT PROCEDURE..... 27

10.2. TEST SET-UP (BLOCK DIAGRAM OF CONFIGURATION) ..... 27

10.3. MEASUREMENT EQUIPMENT USED ..... 27

10.4. LIMITS AND MEASUREMENT RESULT..... 27

**11. RADIATED EMISSION ..... 29**

11.1. MEASUREMENT PROCEDURE..... 29

11.2. TEST SETUP..... 30

11.3. LIMITS AND MEASUREMENT RESULT..... 31

11.4. TEST RESULT..... 31

**12. LINE CONDUCTED EMISSION TEST ..... 41**

12.1. LIMITS OF LINE CONDUCTED EMISSION TEST..... 41

12.2. BLOCK DIAGRAM OF LINE CONDUCTED EMISSION TEST ..... 41

12.3. PRELIMINARY PROCEDURE OF LINE CONDUCTED EMISSION TEST.....	42
12.4. FINAL PROCEDURE OF LINE CONDUCTED EMISSION TEST .....	42
12.5. TEST RESULT OF LINE CONDUCTED EMISSION TEST .....	42
<b>APPENDIX A: PHOTOGRAPHS OF TEST SETUP .....</b>	<b>43</b>
<b>APPENDIX B: PHOTOGRAPHS OF EUT .....</b>	<b>43</b>

## 1. VERIFICATION OF COMPLIANCE

<b>Applicant</b>	ShenZhen Rapoo Technology Co., Ltd.
<b>Address</b>	22, Jinxiu Road East, Pingshan District, Shenzhen, China
<b>Manufacturer</b>	ShenZhen Rapoo Technology Co., Ltd.
<b>Address</b>	22, Jinxiu Road East, Pingshan District, Shenzhen, China
<b>Factory</b>	ShenZhen Rapoo Technology Co., Ltd.
<b>Address</b>	22, Jinxiu Road East, Pingshan District, Shenzhen, China
<b>Product Designation</b>	2.4G keyboard
<b>Brand Name</b>	RAPOO
<b>Test Model</b>	E1050
<b>Series Model</b>	K800, K260S, K8200P, K1800Plus, K1800Pro
<b>Declaration of Difference</b>	All the series models are the same as the test model except for the model names.
<b>Date of test</b>	Mar 01, 2022 to Mar 05, 2022
<b>Deviation</b>	No any deviation from the test method
<b>Condition of Test Sample</b>	Normal
<b>Test Result</b>	Pass
<b>Report Template</b>	AGCRT-US-BLE/RF

We hereby certify that:

The above equipment was tested by Attestation of Global Compliance (Shenzhen) Co., Ltd. The test data, data evaluation, test procedures, and equipment configurations shown in this report were made in accordance with the procedures given in ANSI C63.10 (2013) and the energy emitted by the sample EUT tested as described in this report is in compliance with radiated emission limits of FCC part 15.247.

Prepared By



Kelly Cheng  
(Project Engineer)

Mar. 05, 2022

Reviewed By



Calvin Liu  
(Reviewer)

Mar. 05, 2022

Approved By



Max Zhang  
(Authorized Officer)

Mar. 05, 2022

## 2. GENERAL INFORMATION

### 2.1. PRODUCT DESCRIPTION

The EUT is designed as a “2.4G keyboard”. It is designed by way of utilizing the GFSK technology to achieve the system operation.

A major technical description of EUT is described as following

<b>Operation Frequency</b>	2.402 GHz to 2.479GHz
<b>RF Output Power</b>	-0.377dBm (Max)
<b>Modulation</b>	GFSK
<b>Number of channels</b>	78 Channels
<b>Antenna Designation</b>	PCB Antenna (Comply with requirements of the FCC part 15.203)
<b>Antenna Gain</b>	2.594dBi
<b>Hardware Version</b>	V1.1
<b>Software Version</b>	V1.0
<b>Power Supply</b>	DC 1.5V by battery

**2.2. TABLE OF CARRIER FREQUENCIES**

<b>Channel Number</b>	<b>Frequency</b>	<b>Channel Number</b>	<b>Frequency</b>	<b>Channel Number</b>	<b>Frequency</b>
0	2402 MHz	26	2428 MHz	52	2454 MHz
1	2403 MHz	27	2429 MHz	53	2455 MHz
2	2404 MHz	28	2430 MHz	54	2456 MHz
3	2405 MHz	29	2431 MHz	55	2457 MHz
4	2406 MHz	30	2432 MHz	56	2458 MHz
5	2407 MHz	31	2433 MHz	57	2459 MHz
6	2408 MHz	32	2434 MHz	58	2460 MHz
7	2409 MHz	33	2435 MHz	59	2461 MHz
8	2410 MHz	34	2436 MHz	60	2462 MHz
9	2411 MHz	35	2437 MHz	61	2463 MHz
10	2412 MHz	36	2438 MHz	62	2464 MHz
11	2413 MHz	37	2439 MHz	63	2465 MHz
12	2414 MHz	38	2440 MHz	64	2466 MHz
13	2415 MHz	39	2441 MHz	65	2467 MHz
14	2416 MHz	40	2442 MHz	66	2468 MHz
15	2417 MHz	41	2443 MHz	67	2469 MHz
16	2418 MHz	42	2444 MHz	68	2470 MHz
17	2419 MHz	43	2445 MHz	69	2471 MHz
18	2420 MHz	44	2446 MHz	70	2472 MHz
19	2421 MHz	45	2447 MHz	71	2473 MHz
20	2422 MHz	46	2448 MHz	72	2474 MHz
21	2423 MHz	47	2449 MHz	73	2475 MHz
22	2424 MHz	48	2450 MHz	74	2476 MHz
23	2425 MHz	49	2451 MHz	75	2477 MHz
24	2426 MHz	50	2452 MHz	76	2478 MHz
25	2427 MHz	51	2453 MHz	77	2479 MHz

### **2.3. RELATED SUBMITTAL(S)/GRANT(S)**

This submittal(s) (test report) is intended for **FCC ID: PP22989** filing to comply with the FCC Part 15.247 requirements.

### **2.4. TEST METHODOLOGY**

Both conducted and radiated testing was performed according to the procedures in ANSI C63.10 (2013). Radiated testing was performed at an antenna to EUT distance 3 meters.

### **2.5. SPECIAL ACCESSORIES**

Refer to section 5.2.

### **2.6. EQUIPMENT MODIFICATIONS**

Not available for this EUT intended for grant.

### **2.7. ANTENNA REQUIREMENT**

This intentional radiator is designed with a permanently attached antenna of an antenna to ensure that no antenna other than that furnished by the responsible party shall be used with the device. For more information of the antenna, please refer to the APPENDIX B: PHOTOGRAPHS OF EUT.



### 3. MEASUREMENT UNCERTAINTY

The reported uncertainty of measurement  $y \pm U$ , where expanded uncertainty  $U$  is based on a standard uncertainty multiplied by a coverage factor of  $k=2$ , providing a level of confidence of approximately 95%.

Item	Measurement Uncertainty
Uncertainty of Conducted Emission for AC Port	$U_c = \pm 3.1$ dB
Uncertainty of Radiated Emission below 1GHz	$U_c = \pm 4.0$ dB
Uncertainty of Radiated Emission above 1GHz	$U_c = \pm 4.8$ dB
Uncertainty of total RF power, conducted	$U_c = \pm 0.8$ dB
Uncertainty of RF power density, conducted	$U_c = \pm 2.6$ dB
Uncertainty of spurious emissions, conducted	$U_c = \pm 2$ %
Uncertainty of Occupied Channel Bandwidth	$U_c = \pm 2$ %

#### 4. DESCRIPTION OF TEST MODES

NO.	TEST MODE DESCRIPTION
1	Low channel TX
2	Middle channel TX
3	High channel TX

Note:

1. Only the result of the worst case was recorded in the report, if no other cases.
2. For Radiated Emission, 3axis were chosen for testing for each applicable mode.
3. For Conducted Test method, a temporary antenna connector is provided by the manufacture.
4. The test is by press key which can transmit command into the individual test modes.

## 5. SYSTEM TEST CONFIGURATION

### 5.1. CONFIGURATION OF TESTED SYSTEM

Radiated Emission Configure:

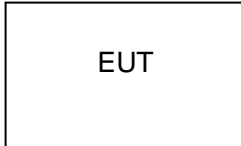

### 5.2. EQUIPMENT USED IN TESTED SYSTEM

Item	Equipment	Model No.	ID or Specification	Remark
1	2.4G keyboard	E1050	PP22989	EUT

### 5.3. SUMMARY OF TEST RESULTS

FCC RULES	DESCRIPTION OF TEST	RESULT
15.247 (b)(3)	Peak Output Power	Compliant
15.247 (a)(2)	6 dB Bandwidth	Compliant
15.247 (d)	Conducted Spurious Emission	Compliant
15.247 (e)	Maximum Conducted Output Power Density	Compliant
15.209	Radiated Emission	Compliant
15.207	Conducted Emission	Not applicable

Note: The EUT is battery operated without AC mains.

## 6. TEST FACILITY

<b>Test Site</b>	Attestation of Global Compliance (Shenzhen) Co., Ltd
<b>Location</b>	1-2/F, Building 19, Junfeng Industrial Park, Chongqing Road, Heping Community, Fuhai Street, Bao'an District, Shenzhen, Guangdong, China
<b>Designation Number</b>	CN1259
<b>FCC Test Firm Registration Number</b>	975832
<b>A2LA Cert. No.</b>	5054.02
<b>Description</b>	Attestation of Global Compliance (Shenzhen) Co., Ltd is accredited by A2LA

### TEST EQUIPMENT OF RADIATED EMISSION TEST

Equipment	Manufacturer	Model	S/N	Cal. Date	Cal. Due
TEST RECEIVER	R&S	ESCI	10096	May 15,2021	May 14,2022
EXA Signal Analyzer	Aglient	N9010A	MY53470504	Nov. 17, 2021	Nov. 16, 2022
2.4GHz Filter	EM Electronics	2400-2500MHz	N/A	Mar. 23, 2020	Mar. 22, 2022
Attenuator	ZHINAN	E-002	N/A	Sep. 03, 2020	Sep. 02, 2022
Horn antenna	SCHWARZBECK	BBHA 9170	#768	Oct. 31, 2021	Oct. 30, 2023
Active loop antenna (9K-30MHz)	ZHINAN	ZN30900C	18051	May 22, 2020	May 21, 2022
Double-Ridged Waveguide Horn	ETS LINDGREN	3117	00034609	Apr. 23, 2021	Apr. 22, 2023
Broadband Preamplifier	ETS LINDGREN	3117PA	00225134	Sep. 03, 2020	Sep. 02, 2022
ANTENNA	SCHWARZBECK	VULB9168	494	Jan. 08, 2021	Jan. 07, 2023
Test software	Tonscend	JS32-RE (Ver.2.5)	N/A	N/A	N/A

## 7. PEAK OUTPUT POWER

### 7.1. MEASUREMENT PROCEDURE

For peak power test:

1. Connect EUT RF output port to the Spectrum Analyzer through an RF attenuator
2.  $RBW \geq DTS$  bandwidth
3.  $VBW \geq 3 * RBW$ .
4.  $SPAN \geq VBW$ .
5. Sweep: Auto.
6. Detector function: Peak.
7. Trace: Max hold.

Allow trace to stabilize. Use the marker-to-peak function to set the marker to the peak of the emission. The indicated level is the peak output power, after any corrections for external attenuators and cables.

### 7.2. TEST SET-UP (BLOCK DIAGRAM OF CONFIGURATION) PEAK POWER TEST SETUP

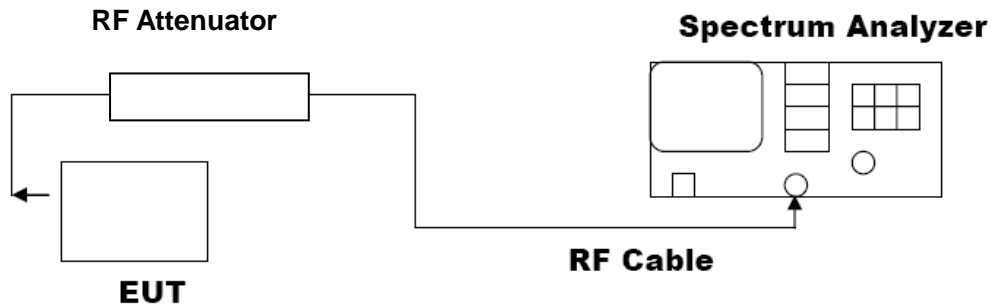

7.3. LIMITS AND MEASUREMENT RESULT

Test Data of Conducted Output Power				
Test Mode	Test Channel (MHz)	Peak Power (dBm)	Limits (dBm)	Pass or Fail
GFSK	2402	-0.377	≤30	Pass
	2446	-1.115	≤30	Pass
	2479	-1.854	≤30	Pass

Test Graphs of Conducted Output Power

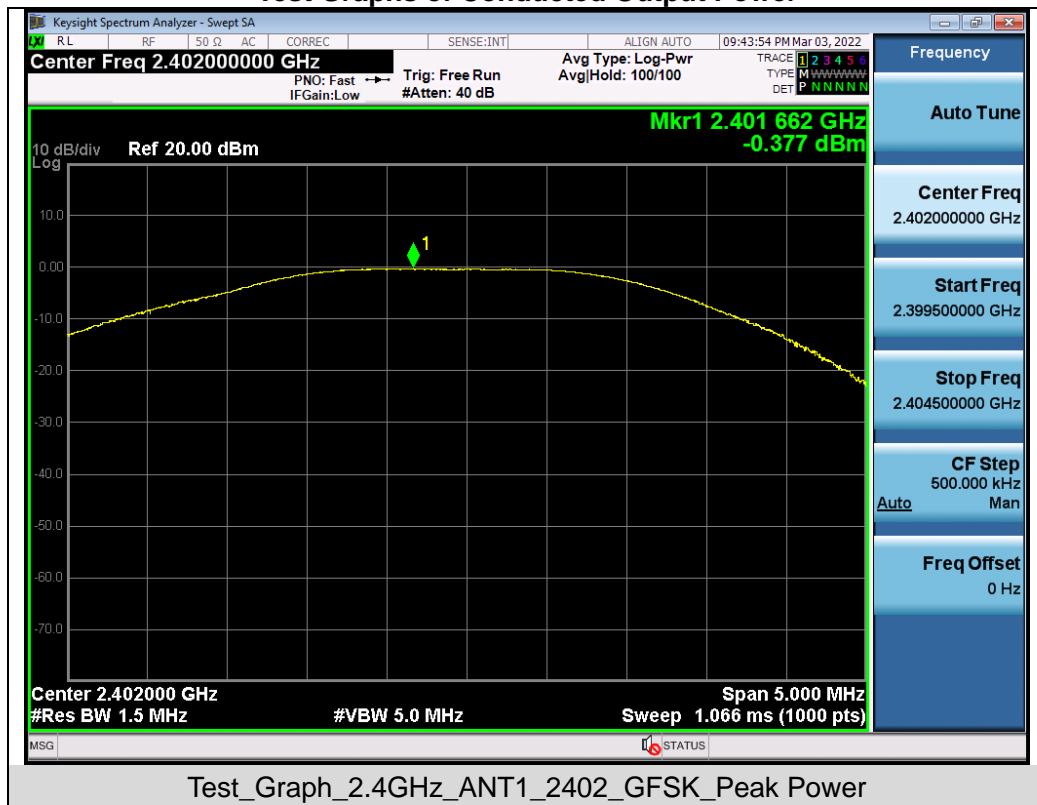



Test\_Graph\_2.4GHz\_ANT1\_2446\_GFSK\_Peak Power



Test\_Graph\_2.4GHz\_ANT1\_2479\_GFSK\_Peak Power

## 8. BANDWIDTH

### 8.1. MEASUREMENT PROCEDURE

6dB bandwidth:

1. Connect EUT RF output port to the Spectrum Analyzer through an RF attenuator
2. Set the EUT Work on the top, the middle and the bottom operation frequency individually.
3. Set SPA Centre Frequency = Operation Frequency, RBW= 100 kHz, VBW  $\geq 3 \times$  RBW.
4. Set SPA Trace 1 Max hold, then View.

Occupied bandwidth:

1. Connect EUT RF output port to the Spectrum Analyzer through an RF attenuator
2. Set the EUT Work on the top, the middle and the bottom operation frequency individually.
3. Set Span = approximately 2 to 5 times the 20 dB bandwidth, centered on a hopping channel  
The nominal IF filter bandwidth (3 dB RBW) shall be in the range of 1% to 5% of the OBW and video bandwidth (VBW) shall be approximately three times RBW; Sweep = auto; Detector function = peak
4. Set SPA Trace 1 Max hold, then View.

**Note:** The EUT was tested according to ANSI C63.10 for compliance to FCC PART 15.247 requirements.

### 8.2. TEST SET-UP (BLOCK DIAGRAM OF CONFIGURATION)

The same as described in section 7.2.

### 8.3. LIMITS AND MEASUREMENT RESULTS

Test Data of Occupied Bandwidth and DTS Bandwidth					
Test Mode	Test Channel (MHz)	99% Occupied Bandwidth (MHz)	-6dB Bandwidth (MHz)	Limits (MHz)	Pass or Fail
GFSK	2402	1.4734	1.027	$\geq 0.5$	Pass
	2446	1.5844	1.054	$\geq 0.5$	Pass
	2479	1.5680	1.024	$\geq 0.5$	Pass



### Test Graphs of Occupied Bandwidth



Test\_Graph\_2.4GHz\_ANT1\_2402\_GFSK\_OBW



Test\_Graph\_2.4GHz\_ANT1\_2446\_GFSK\_OBW

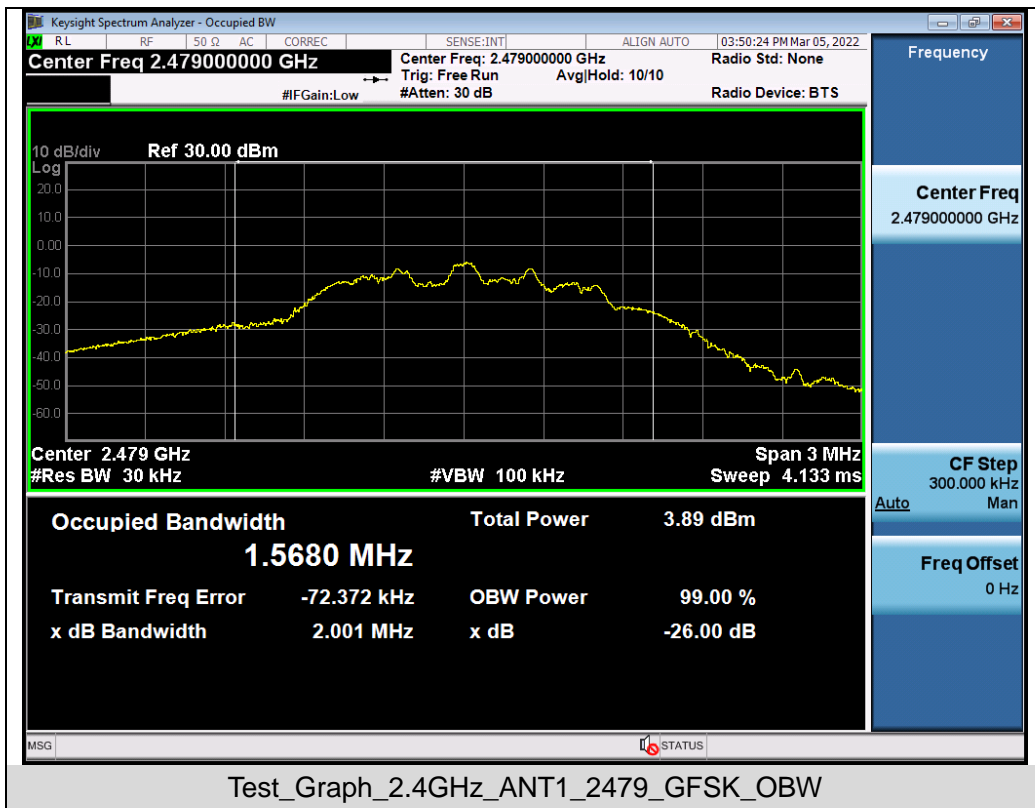

Test Graphs of DTS Bandwidth

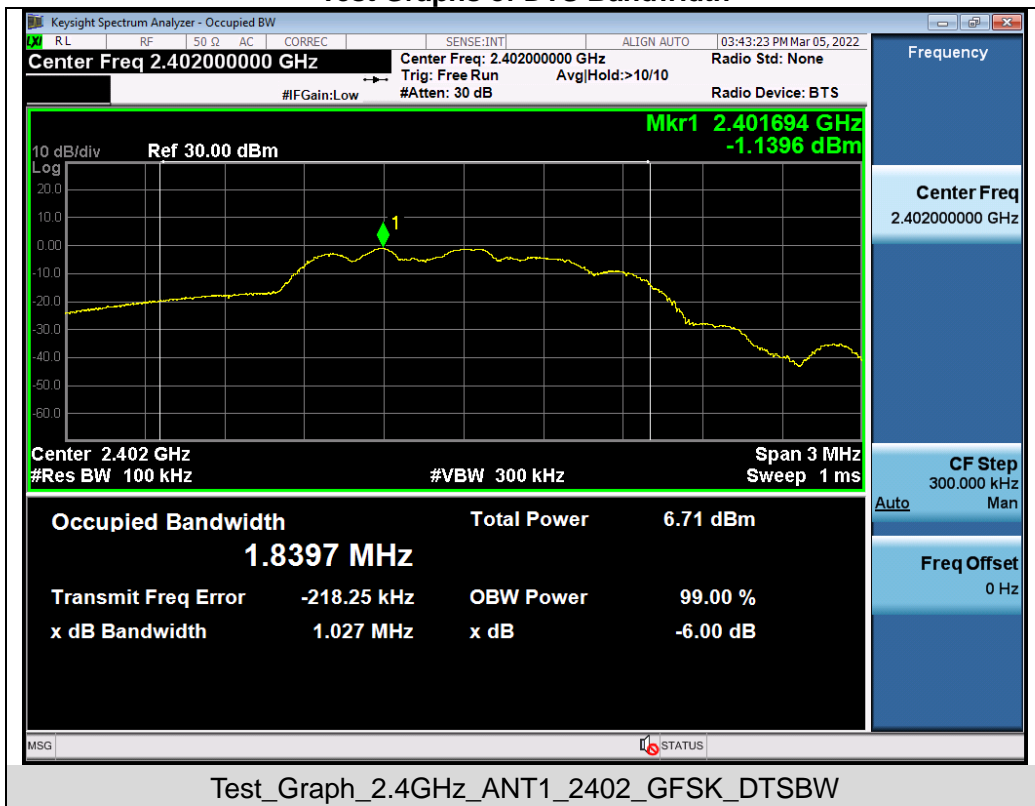

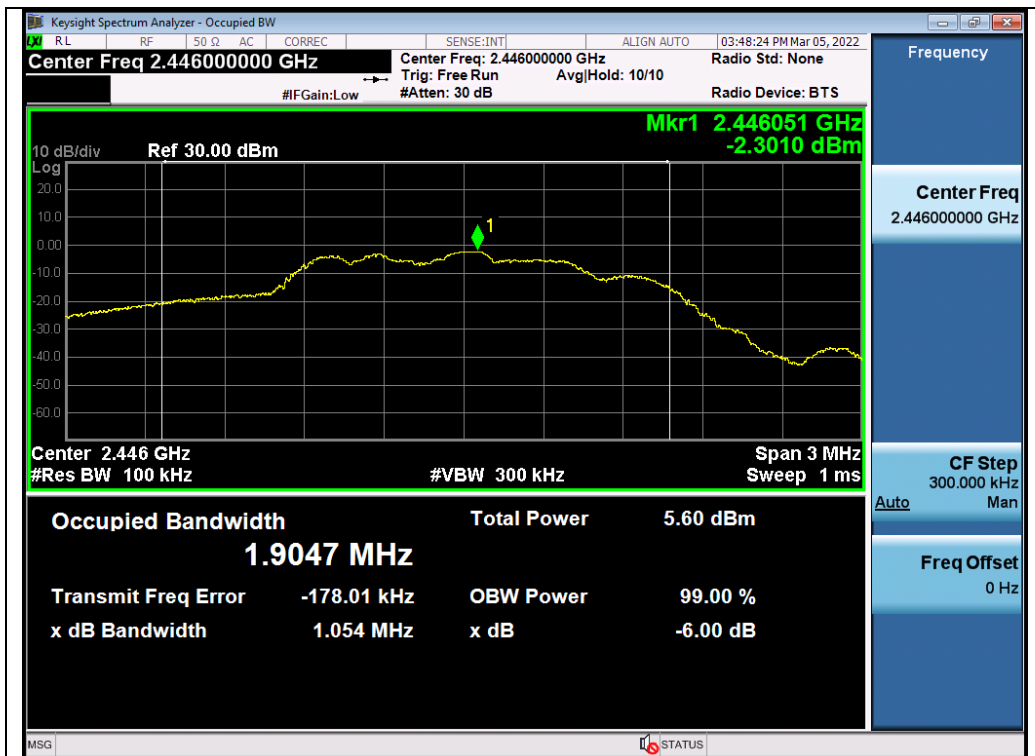

Test\_Graph\_2.4GHz\_ANT1\_2446\_GFSK\_DTSSBW

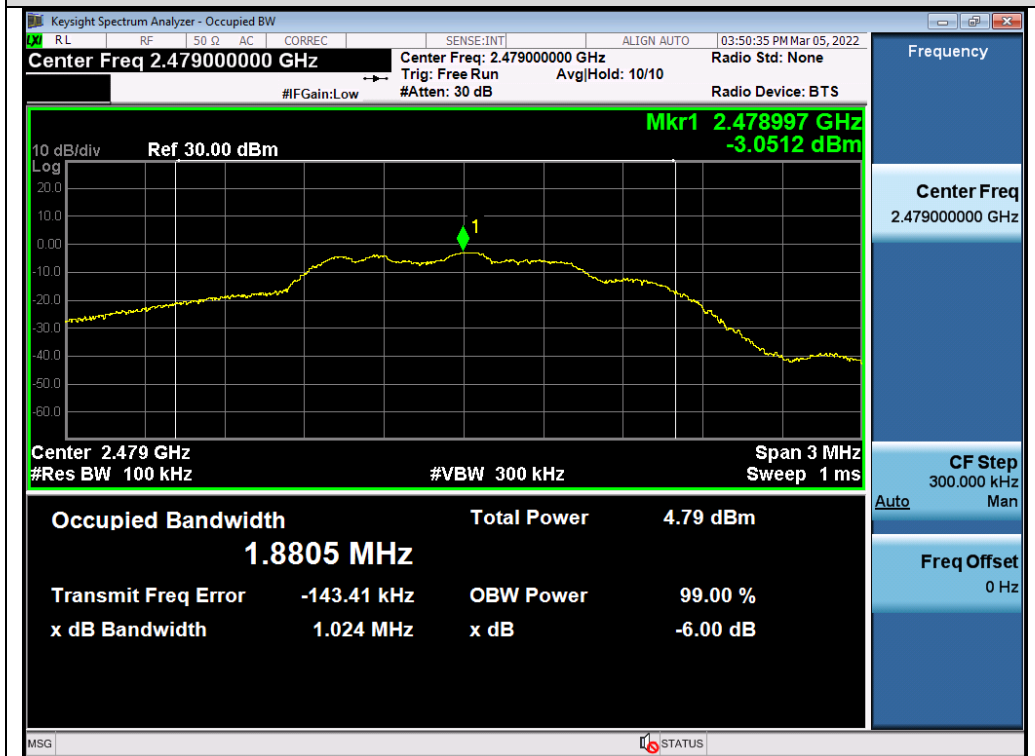

Test\_Graph\_2.4GHz\_ANT1\_2479\_GFSK\_DTSSBW

## 9. CONDUCTED SPURIOUS EMISSION

### 9.1. MEASUREMENT PROCEDURE

1. Connect EUT RF output port to the Spectrum Analyzer through an RF attenuator
2. Set the EUT Work on the top, the middle and the bottom operation frequency individually.
3. Set SPA Trace 1 Max hold, then View.

**Note:** The EUT was tested according to ANSI C63.10 for compliance to FCC PART 15.247 requirements.

### 9.2. TEST SET-UP (BLOCK DIAGRAM OF CONFIGURATION)

The same as described in section 7.2.

### 9.3. MEASUREMENT EQUIPMENT USED

The same as described in section 6.

### 9.4. LIMITS AND MEASUREMENT RESULT

LIMITS AND MEASUREMENT RESULT		
Applicable Limits	Measurement Result	
	Test Data	Criteria
In any 100 kHz Bandwidth Outside the frequency band in which the spread spectrum intentional radiator is operating, the radio frequency power that is produce by the intentional radiator shall be at least 20 dB below that in 100KHz bandwidth within the band that contains the highest level of the desired power.	At least -20dBc than the reference level	PASS

### Test Graphs of Spurious Emissions in Non-Restricted Frequency Bands



Test\_Graph\_2.4GHz\_ANT1\_2402\_GFSK\_Reference Level

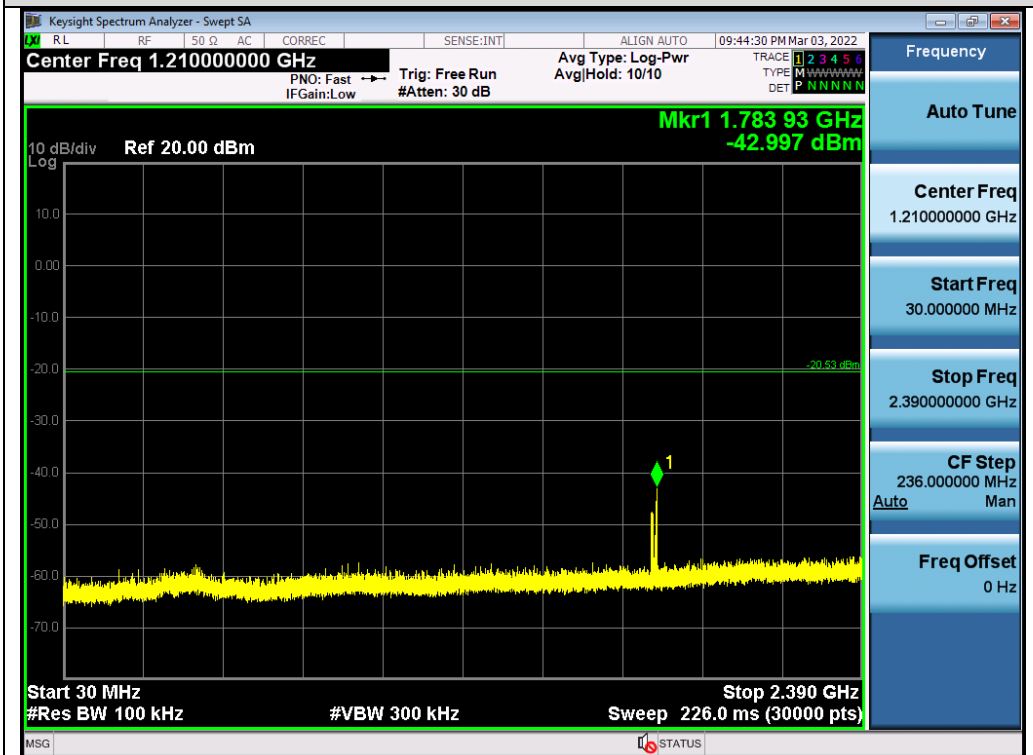

Test\_Graph\_2.4GHz\_ANT1\_2402\_GFSK\_Lower Band Emissions

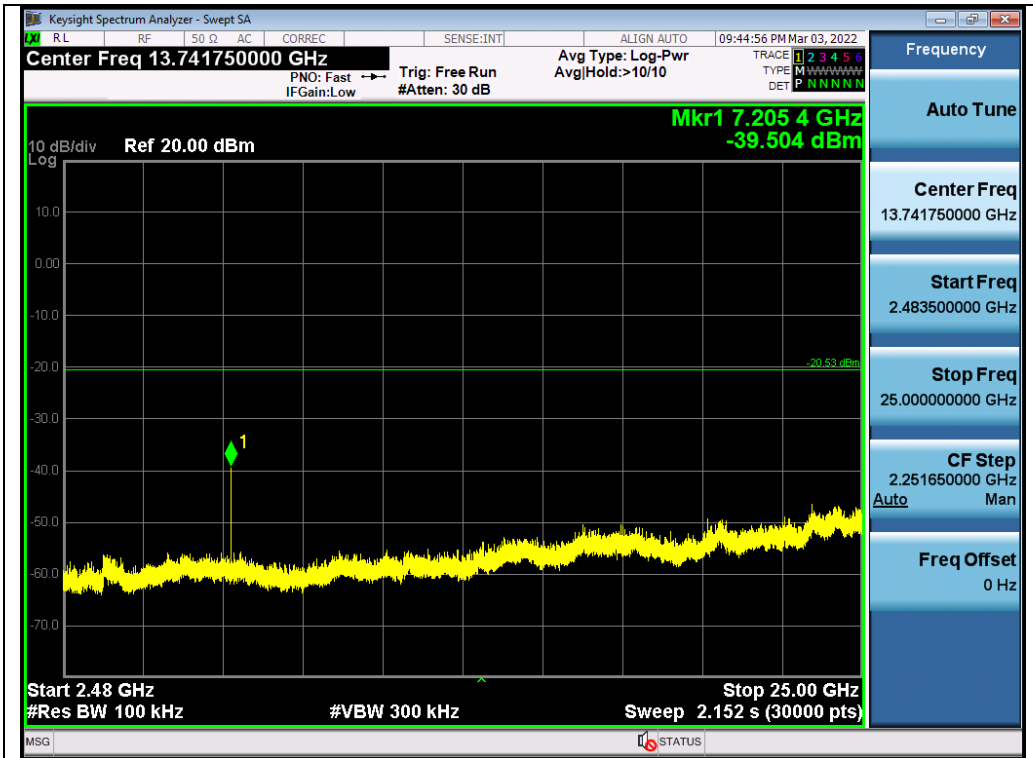

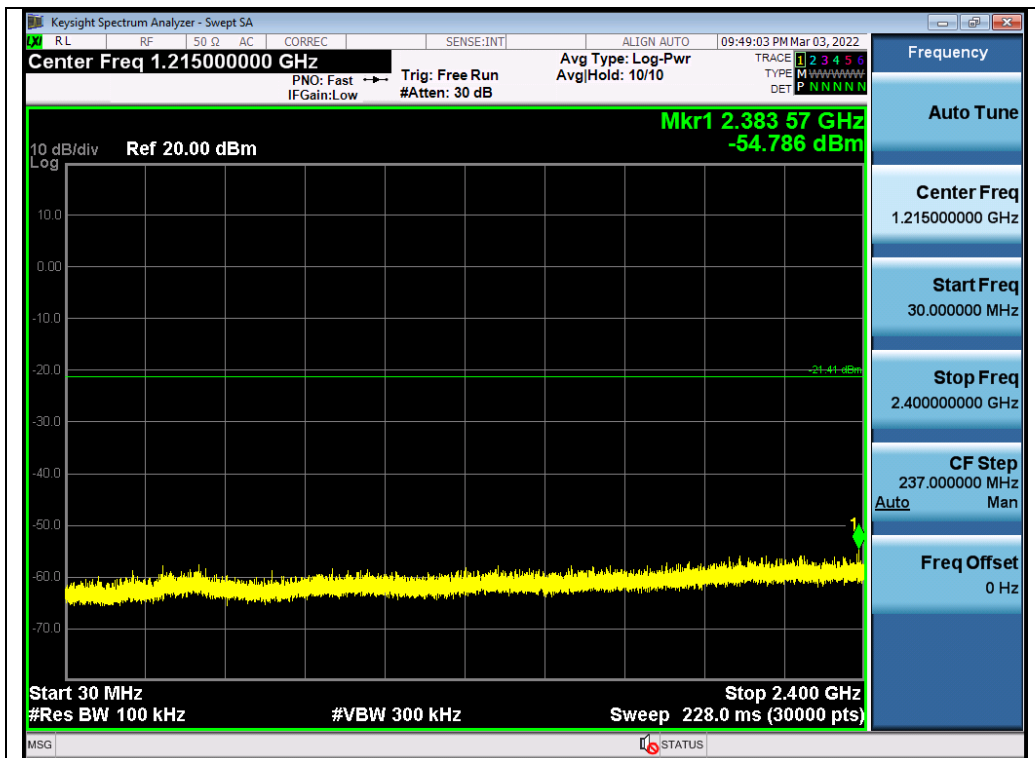

Test\_Graph\_2.4GHz\_ANT1\_2446\_GFSK\_Lower Band Emissions

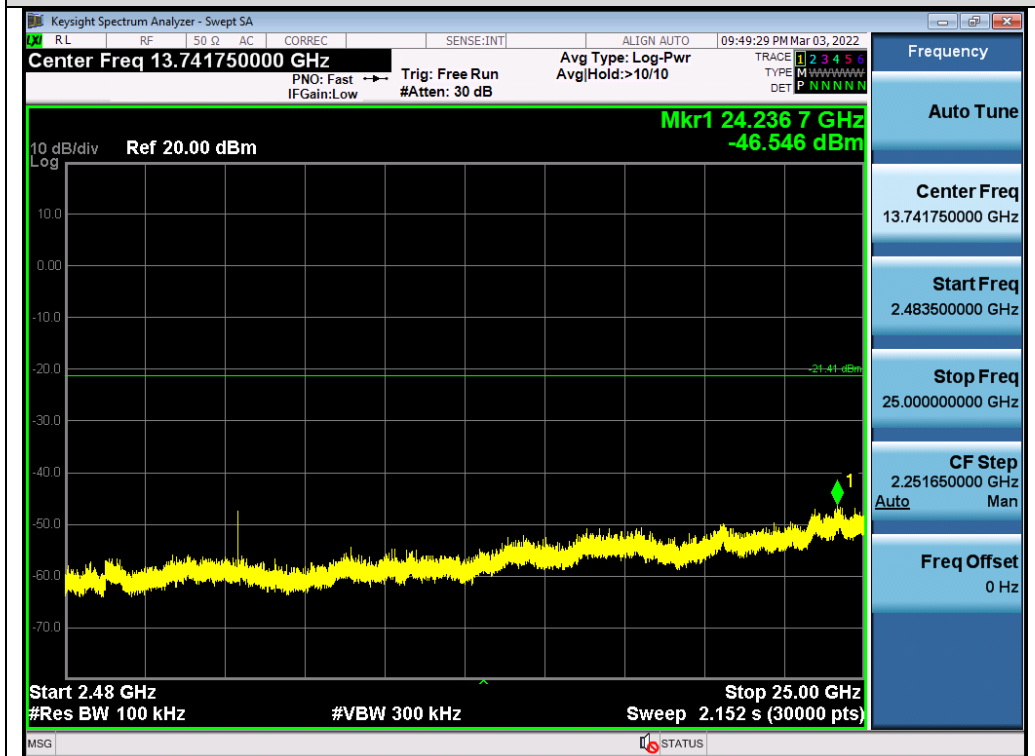

Test\_Graph\_2.4GHz\_ANT1\_2446\_GFSK\_Higher Band Emissions



Test\_Graph\_2.4GHz\_ANT1\_2479\_GFSK\_Reference Level

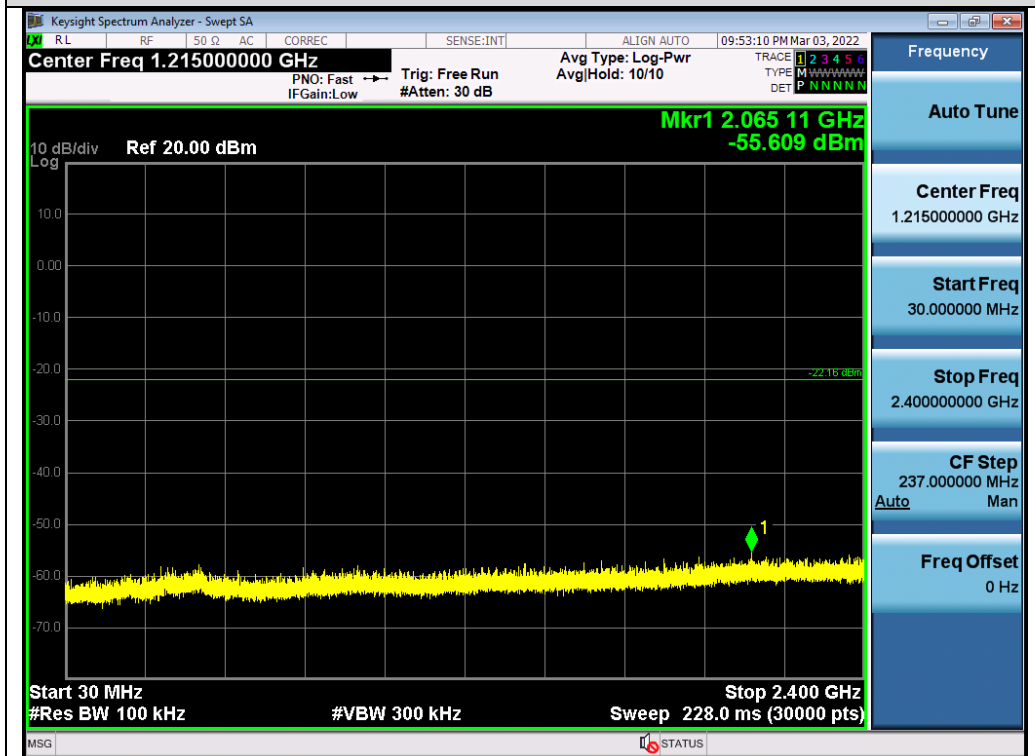

Test\_Graph\_2.4GHz\_ANT1\_2479\_GFSK\_Lower Band Emissions



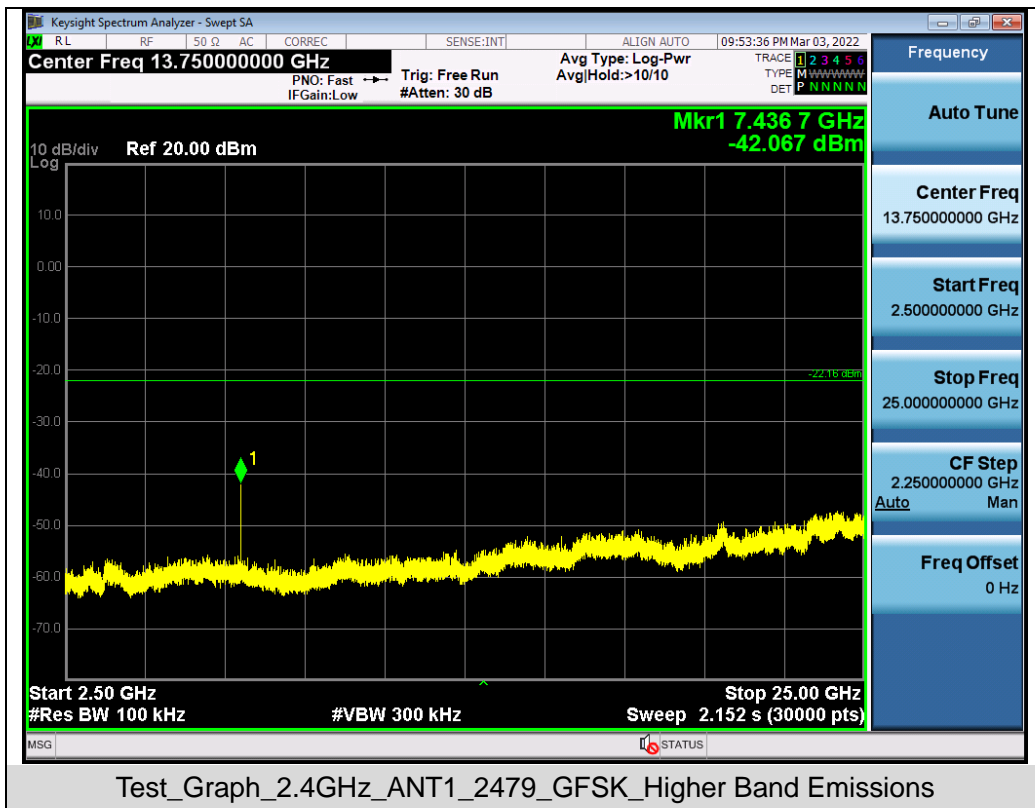

### Test Graphs of Band Edge Emissions in Non-Restricted Frequency Bands

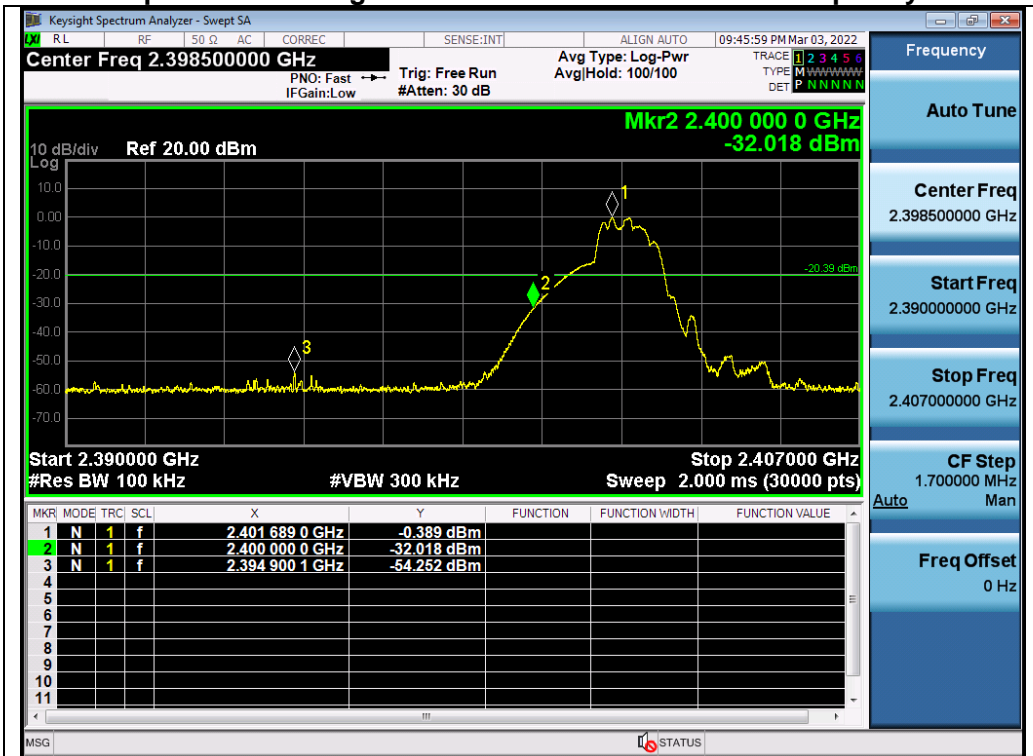

Test\_Graph\_2.4GHz\_ANT1\_2402\_GFSK\_Lower Band Edge Emissions

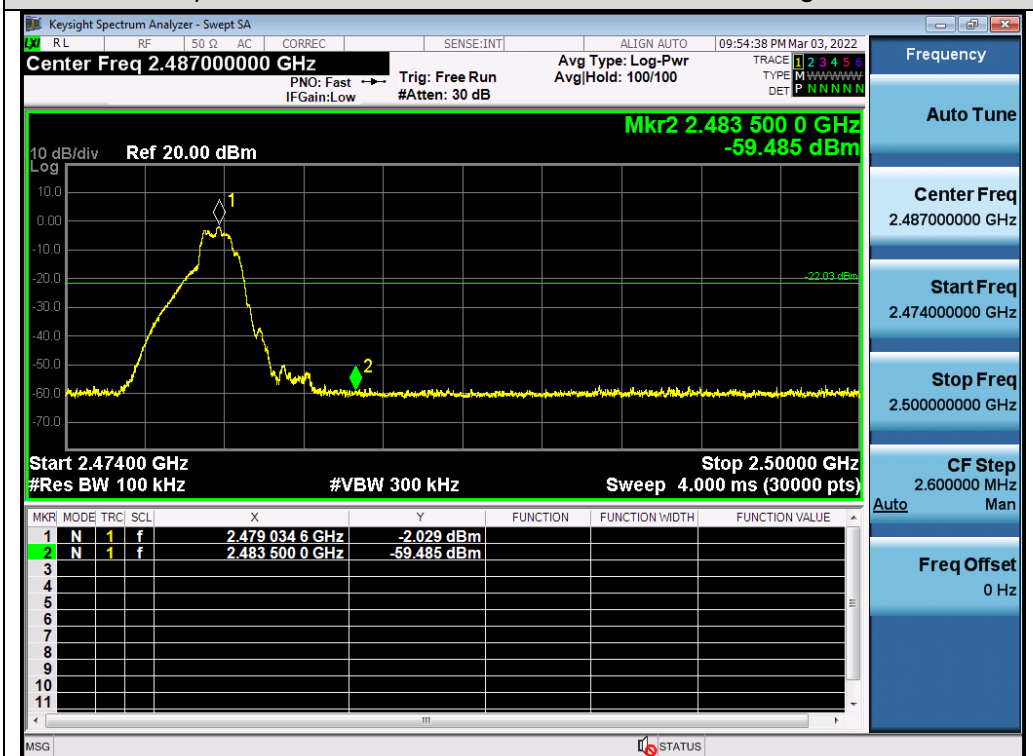

Test\_Graph\_2.4GHz\_ANT1\_2479\_GFSK\_Higher Band Edge Emissions

## 10. MAXIMUM CONDUCTED OUTPUT POWER SPECTRAL DENSITY

### 10.1. MEASUREMENT PROCEDURE

- (1). Connect EUT RF output port to the Spectrum Analyzer through an RF attenuator
- (2). Set the EUT Work on the top, the middle and the bottom operation frequency individually.
- (3). Set the SPA Trace 1 Max hold, then View.

Note: The method of PKPSD in the KDB 558074 item 8.4 was used in this testing.

### 10.2. TEST SET-UP (BLOCK DIAGRAM OF CONFIGURATION)

Refer to Section 7.2.

### 10.3. MEASUREMENT EQUIPMENT USED

Refer to Section 6.

### 10.4. LIMITS AND MEASUREMENT RESULT

Test Data of Conducted Output Power Spectral Density				
Test Mode	Test Channel (MHz)	Power density (dBm/3kHz)	Limit (dBm/3kHz)	Pass or Fail
GFSK	2402	-15.127	≤ 8	Pass
	2446	-9.525	≤ 8	Pass
	2479	-10.285	≤ 8	Pass

Test Graphs of Conducted Output Power Spectral Density

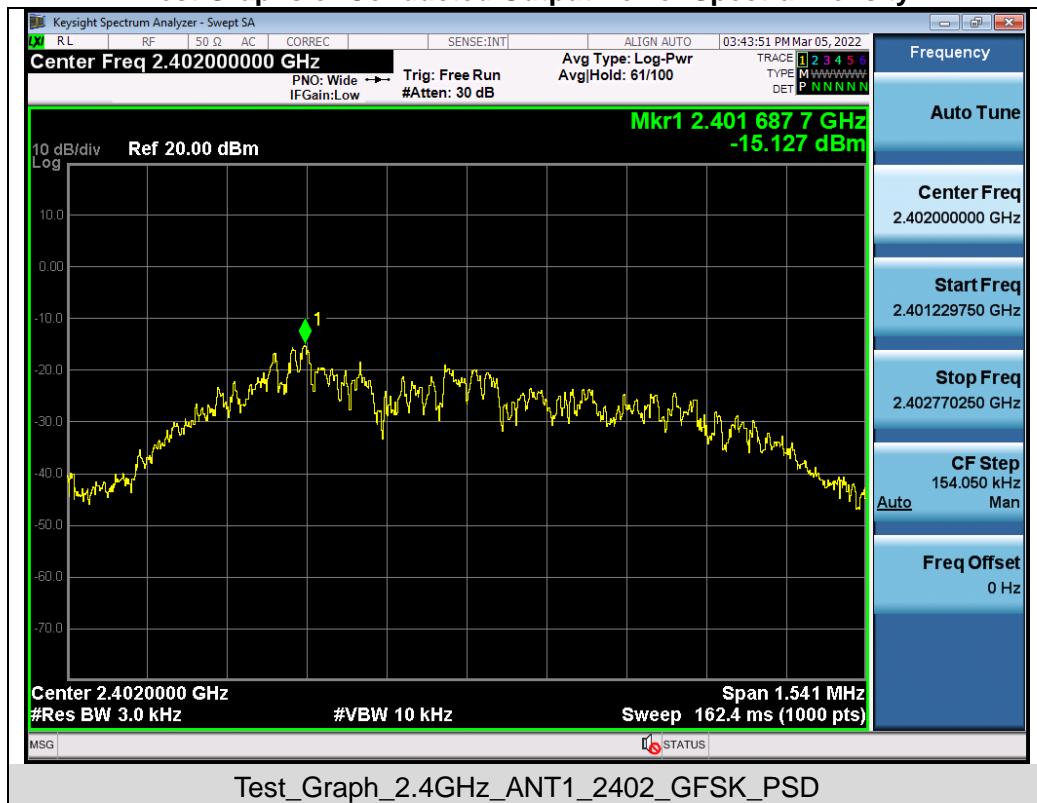



Test\_Graph\_2.4GHz\_ANT1\_2446\_GFSK\_PSD



Test\_Graph\_2.4GHz\_ANT1\_2479\_GFSK\_PSD

## 11. RADIATED EMISSION

### 11.1. MEASUREMENT PROCEDURE

1. The EUT was placed on the top of the turntable 0.8 or 1.5 meter above ground. The phase center of the receiving antenna mounted on the top of a height-variable antenna tower was placed 3 meters far away from the turntable.
2. Power on the EUT and all the supporting units. The turntable was rotated by 360 degrees to determine the position of the highest radiation.
3. The height of the broadband receiving antenna was varied between one meter and four meters above ground to find the maximum emissions field strength of both horizontal and vertical polarization.
4. For each suspected emission, the antenna tower was scan (from 1 M to 4 M) and then the turntable was rotated (from 0 degree to 360 degrees) to find the maximum reading.
5. Set the test-receiver system to Peak or CISPR quasi-peak Detect Function with specified bandwidth under Maximum Hold Mode.
6. For emissions above 1GHz, use 1MHz RBW and 3MHz VBW for peak reading. Place the measurement antenna away from each area of the EUT determined to be a source of emissions at the specified measurement distance, while keeping the measurement antenna aimed at the source of emissions at each frequency of significant emissions, with polarization oriented for maximum response. The measurement antenna may have to be higher or lower than the EUT, depending on the radiation pattern of the emission and staying aimed at the emission source for receiving the maximum signal. The final measurement antenna elevation shall be that which maximizes the emissions. The measurement antenna elevation for maximum emissions shall be restricted to a range of heights of from 1 m to 4 m above the ground or reference ground plane.
7. When the radiated emissions limits are expressed in terms of the average value of the emissions, and pulsed operation is employed, the measurement field strength shall be determined by averaging over one complete pulse train, including blanking intervals, as long as the pulse train does not exceed 0.1 seconds. As an alternative (provided the transmitter operates for longer than 0.1 seconds) or in cases where the pulse train exceeds 0.1 seconds, the measured field strength shall be determined from the average absolute voltage during a 0.1 second interval during which the field strength is at its maximum values.
8. If the emissions level of the EUT in peak mode was 3 dB lower than the average limit specified, then testing will be stopped and peak values of EUT will be reported, otherwise, the emissions which do not have 3 dB margin will be repeated one by one using the quasi-peak method for below 1GHz.
9. For testing above 1GHz, the emissions level of the EUT in peak mode was lower than average limit (that means the emissions level in peak mode also complies with the limit in average mode), then testing will be stopped and peak values of EUT will be reported, otherwise, the emissions will be measured in average mode again and reported.
10. In case the emission is lower than 30MHz, loop antenna has to be used for measurement and the recorded data should be QP measured by receiver. High - Low scan is not required in this case.

## 11.2. TEST SETUP

Radiated Emission Test-Setup Frequency Below 30MHz

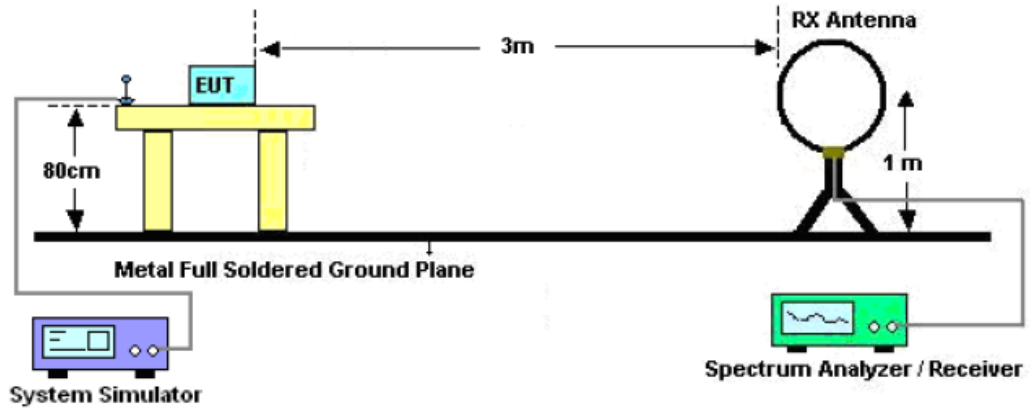

RADIATED EMISSION TEST SETUP 30MHz-1000MHz

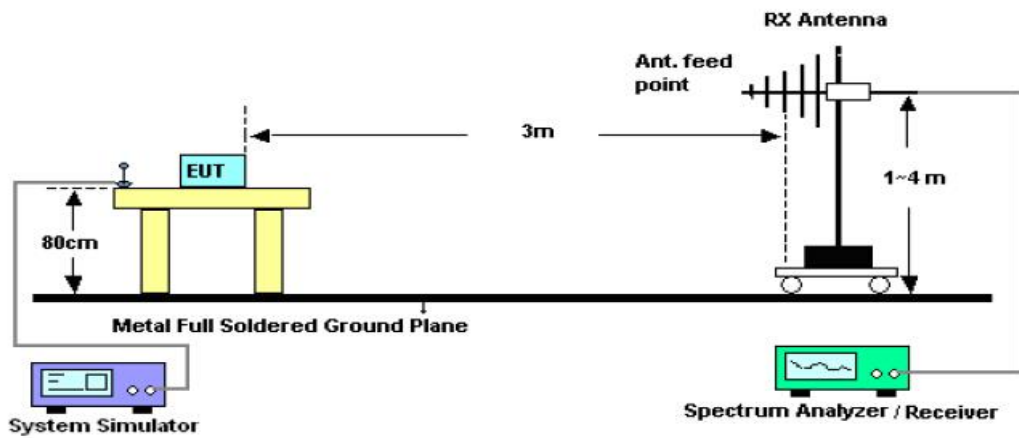

RADIATED EMISSION TEST SETUP ABOVE 1000MHz

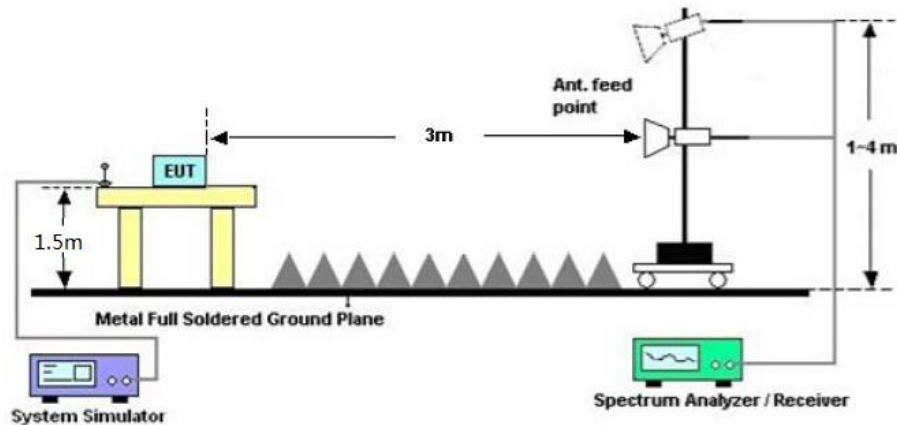

### 11.3. LIMITS AND MEASUREMENT RESULT

15.209 Limit in the below table has to be followed

<b>Frequencies (MHz)</b>	<b>Field Strength (microvolts/meter)</b>	<b>Measurement Distance (meters)</b>
0.009~0.490	2400/F(kHz)	300
0.490~1.705	24000/F(kHz)	30
1.705~30.0	30	30
30~88	100	3
88~216	150	3
216~960	200	3
Above 960	500	3

Note: All modes were tested for restricted band radiated emission, the test records reported below are the worst result compared to other modes.

### 11.4. TEST RESULT

#### **Radiated emission below 30MHz**

The amplitude of spurious emissions from 9kHz to 30MHz which are attenuated more than 20 dB below the permissible value need not be reported.

**Radiated emission from 30MHz to 1000MHz**

<b>EUT</b>	2.4G keyboard	<b>Model Name</b>	E1050
<b>Temperature</b>	21.8° C	<b>Relative Humidity</b>	58%
<b>Pressure</b>	960hPa	<b>Test Voltage</b>	Normal Voltage
<b>Test Mode</b>	Mode 1	<b>Antenna</b>	Horizontal

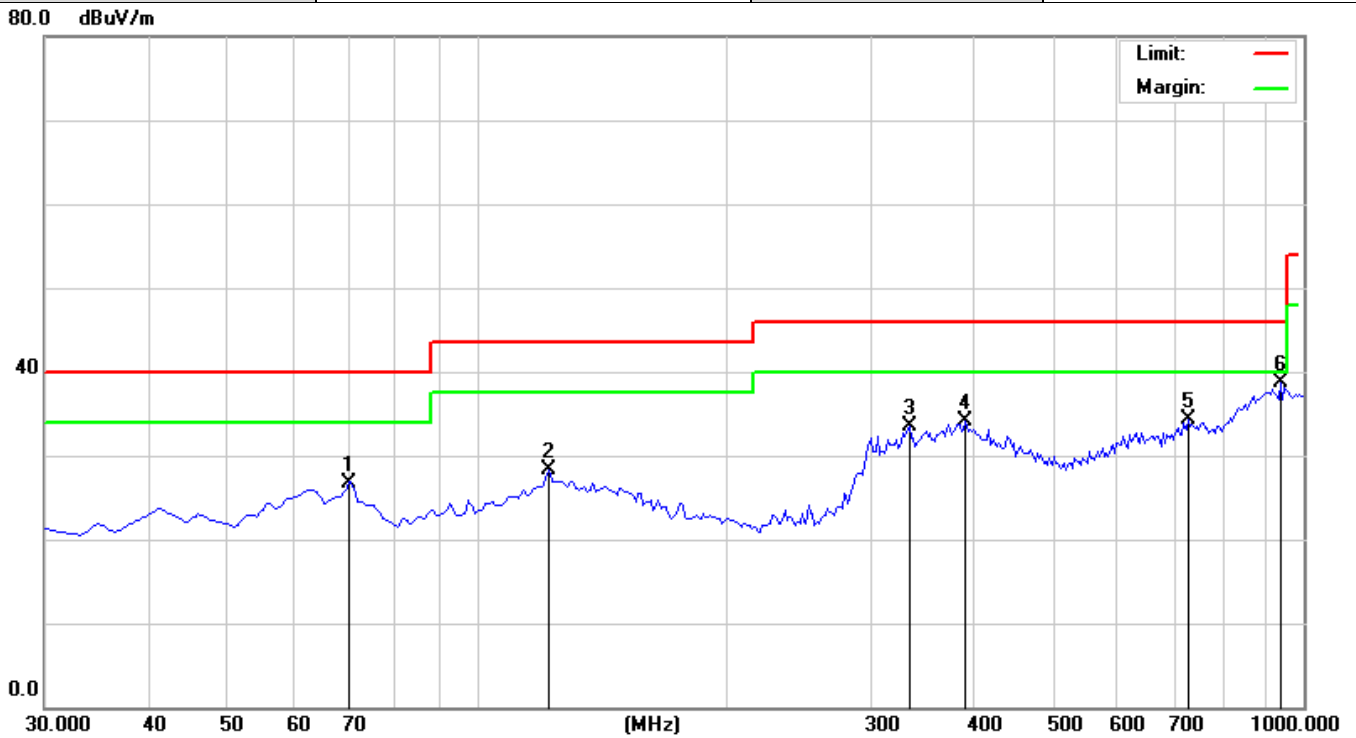

No.	Mk.	Freq. MHz	Reading Level dBuV	Correct Factor dB	Measure- ment dBuV/m	Limit dBuV/m	Over dB	Detector
1		70.4167	14.86	11.94	26.80	40.00	-13.20	peak
2		122.1500	15.35	12.93	28.28	43.50	-15.22	peak
3		333.9333	16.25	17.20	33.45	46.00	-12.55	peak
4		390.5167	15.63	18.47	34.10	46.00	-11.90	peak
5		725.1667	15.90	18.47	34.37	46.00	-11.63	peak
6	*	940.1833	15.87	22.91	38.78	46.00	-7.22	peak

**RESULT: PASS**



<b>EUT</b>	2.4G keyboard	<b>Model Name</b>	E1050
<b>Temperature</b>	21.8° C	<b>Relative Humidity</b>	58%
<b>Pressure</b>	960hPa	<b>Test Voltage</b>	Normal Voltage
<b>Test Mode</b>	Mode 1	<b>Antenna</b>	Vertical

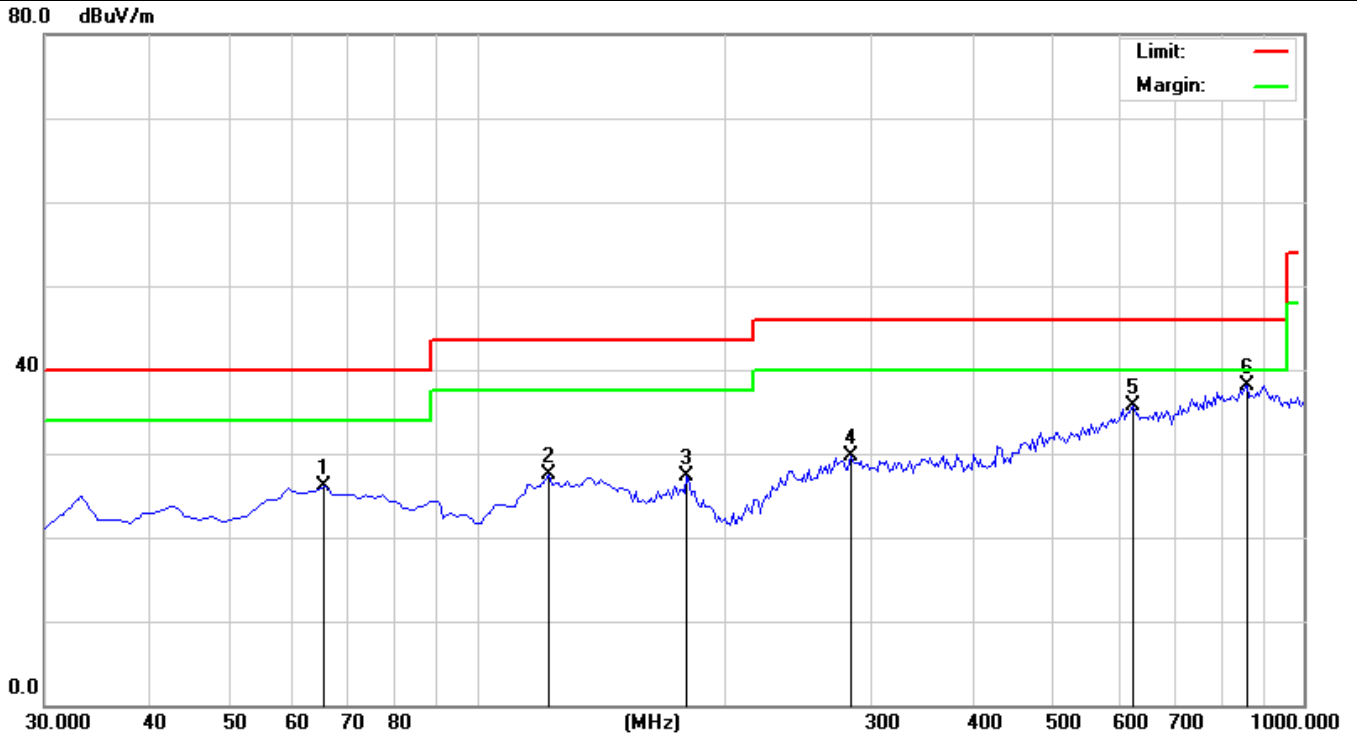

No.	Mk.	Freq. MHz	Reading Level dBuV	Correct Factor dB	Measure- ment dBuV/m	Limit dBuV/m	Over dB	Detector
1		65.5667	14.09	12.00	26.09	40.00	-13.91	peak
2		122.1500	14.50	13.00	27.50	43.50	-16.00	peak
3		180.3500	15.16	12.06	27.22	43.50	-16.28	peak
4		283.8167	14.86	14.85	29.71	46.00	-16.29	peak
5		624.9333	15.64	20.00	35.64	46.00	-10.36	peak
6	*	856.1167	15.66	22.54	38.20	46.00	-7.80	peak

**RESULT: PASS**

**Note:**

1. Factor=Antenna Factor + Cable loss, Over=Measurement-Limit.
2. All test modes had been tested. The mode 1 is the worst case and recorded in the report.

**Radiated emission above 1GHz**

<b>EUT</b>	2.4G keyboard	<b>Model Name</b>	E1050
<b>Temperature</b>	21.8° C	<b>Relative Humidity</b>	58%
<b>Pressure</b>	960hPa	<b>Test Voltage</b>	Normal Voltage
<b>Test Mode</b>	Mode 1	<b>Antenna</b>	Horizontal

Frequency (MHz)	Meter Reading (dBµV)	Factor (dB)	Emission Level (dBµV/m)	Limits (dBµV/m)	Margin (dB)	Value Type
4804.000	43.63	0.08	43.71	74	-30.29	peak
4804.000	35.46	0.08	35.54	54	-18.46	AVG
7206.000	38.34	2.21	40.55	74	-33.45	peak
7206.000	31.28	2.21	33.49	54	-20.51	AVG

Remark:

Factor = Antenna Factor + Cable Loss – Pre-amplifier.

<b>EUT</b>	2.4G keyboard	<b>Model Name</b>	E1050
<b>Temperature</b>	21.8° C	<b>Relative Humidity</b>	58%
<b>Pressure</b>	960hPa	<b>Test Voltage</b>	Normal Voltage
<b>Test Mode</b>	Mode 1	<b>Antenna</b>	Vertical

Frequency (MHz)	Meter Reading (dBµV)	Factor (dB)	Emission Level (dBµV/m)	Limits (dBµV/m)	Margin (dB)	Value Type
4804.000	44.56	0.08	44.64	74	-29.36	peak
4804.000	34.69	0.08	34.77	54	-19.23	AVG
7206.000	38.27	2.21	40.48	74	-33.52	peak
7206.000	30.14	2.21	32.35	54	-21.65	AVG

Remark:

Factor = Antenna Factor + Cable Loss – Pre-amplifier.

<b>EUT</b>	2.4G keyboard	<b>Model Name</b>	E1050
<b>Temperature</b>	21.8° C	<b>Relative Humidity</b>	58%
<b>Pressure</b>	960hPa	<b>Test Voltage</b>	Normal Voltage
<b>Test Mode</b>	Mode 2	<b>Antenna</b>	Horizontal

Frequency (MHz)	Meter Reading (dBµV)	Factor (dB)	Emission Level (dBµV/m)	Limits (dBµV/m)	Margin (dB)	Value Type
4892.000	44.27	0.14	44.41	74	-29.59	peak
4880.000	35.42	0.14	35.56	54	-18.44	AVG
7338.000	39.59	2.36	41.95	74	-32.05	peak
7338.000	31.35	2.36	33.71	54	-20.29	AVG

Remark:

Factor = Antenna Factor + Cable Loss – Pre-amplifier.

<b>EUT</b>	2.4G keyboard	<b>Model Name</b>	E1050
<b>Temperature</b>	21.8° C	<b>Relative Humidity</b>	58%
<b>Pressure</b>	960hPa	<b>Test Voltage</b>	Normal Voltage
<b>Test Mode</b>	Mode 2	<b>Antenna</b>	Vertical

Frequency (MHz)	Meter Reading (dBµV)	Factor (dB)	Emission Level (dBµV/m)	Limits (dBµV/m)	Margin (dB)	Value Type
4892.000	45.51	0.14	45.65	74	-28.35	peak
4880.000	38.25	0.14	38.39	54	-15.61	AVG
7338.000	40.37	2.36	42.73	74	-31.27	peak
7338.000	32.41	2.36	34.77	54	-19.23	AVG

Remark:

Factor = Antenna Factor + Cable Loss – Pre-amplifier.

<b>EUT</b>	2.4G keyboard	<b>Model Name</b>	E1050
<b>Temperature</b>	21.8° C	<b>Relative Humidity</b>	58%
<b>Pressure</b>	960hPa	<b>Test Voltage</b>	Normal Voltage
<b>Test Mode</b>	Mode 3	<b>Antenna</b>	Horizontal

Frequency (MHz)	Meter Reading (dBµV)	Factor (dB)	Emission Level (dBµV/m)	Limits (dBµV/m)	Margin (dB)	Value Type
4958.000	44.77	0.22	44.99	74	-29.01	peak
4958.000	35.54	0.22	35.76	54	-18.24	AVG
7437.000	38.43	2.64	41.07	74	-32.93	peak
7437.000	29.35	2.64	31.99	54	-22.01	AVG

Remark:

Factor = Antenna Factor + Cable Loss – Pre-amplifier.

<b>EUT</b>	2.4G keyboard	<b>Model Name</b>	E1050
<b>Temperature</b>	21.8° C	<b>Relative Humidity</b>	58%
<b>Pressure</b>	960hPa	<b>Test Voltage</b>	Normal Voltage
<b>Test Mode</b>	Mode 3	<b>Antenna</b>	Vertical

Frequency (MHz)	Meter Reading (dBµV)	Factor (dB)	Emission Level (dBµV/m)	Limits (dBµV/m)	Margin (dB)	Value Type
4958.000	42.87	0.22	43.09	74	-30.91	peak
4958.000	34.55	0.22	34.77	54	-19.23	AVG
7437.000	38.59	2.64	41.23	74	-32.77	peak
7437.000	29.73	2.64	32.37	54	-21.63	AVG

Remark:

Factor = Antenna Factor + Cable Loss – Pre-amplifier.

**RESULT: PASS**

**Note:**

The amplitude of other spurious emissions from 1G to 25 GHz which are attenuated more than 20 dB below the permissible value need not be reported.

Factor = Antenna Factor + Cable loss - Amplifier gain, Margin=Level-Limit.

The “Factor” value can be calculated automatically by software of measurement system.

**Test result for band edge emission at restricted bands**

EUT	2.4G keyboard	Model Name	E1050
Temperature	21.8° C	Relative Humidity	58%
Pressure	960hPa	Test Voltage	Normal Voltage
Test Mode	Mode 1	Antenna	Horizontal

Test Graph for Peak Measurement

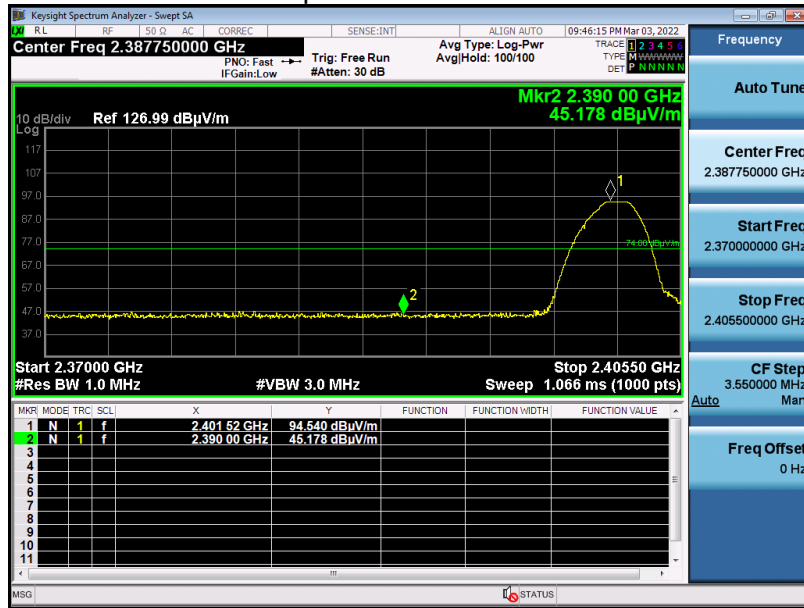

Test Graph for Average Measurement

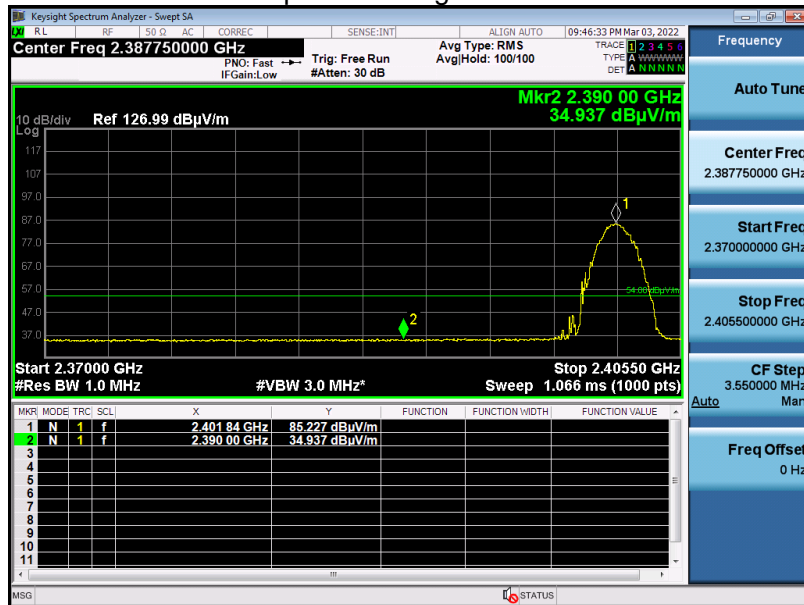

**RESULT: PASS**

EUT	2.4G keyboard	Model Name	E1050
Temperature	21.8° C	Relative Humidity	58%
Pressure	960hPa	Test Voltage	Normal Voltage
Test Mode	Mode 1	Antenna	Vertical

Test Graph for Peak Measurement

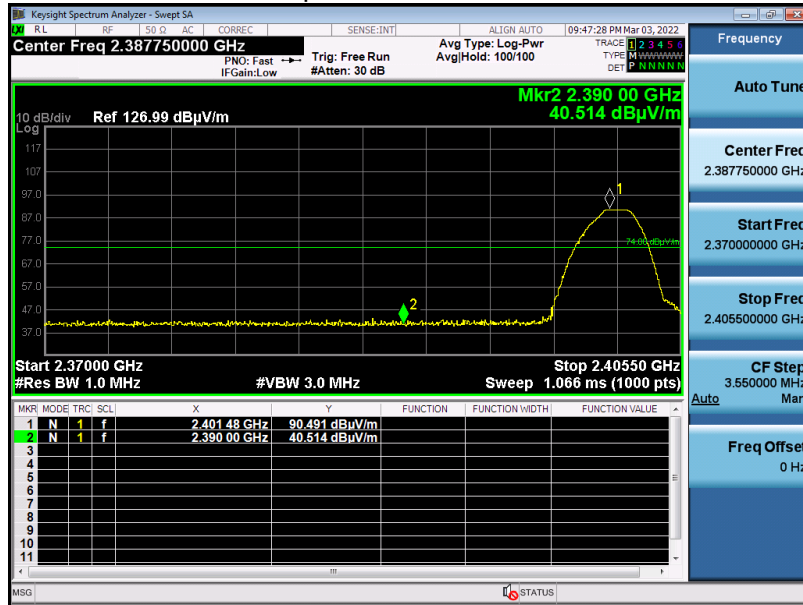

Test Graph for Average Measurement

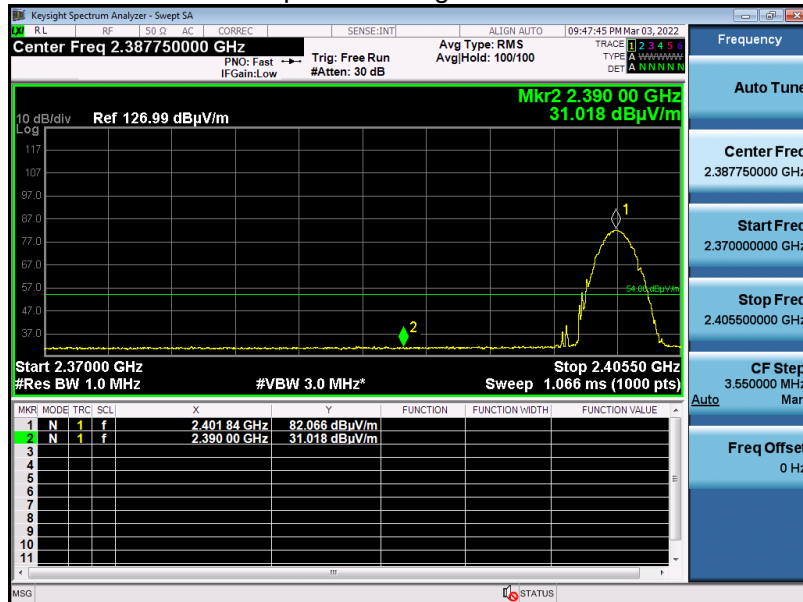

RESULT: PASS

EUT	2.4G keyboard	Model Name	E1050
Temperature	21.8° C	Relative Humidity	58%
Pressure	960hPa	Test Voltage	Normal Voltage
Test Mode	Mode 3	Antenna	Horizontal

Test Graph for Peak Measurement

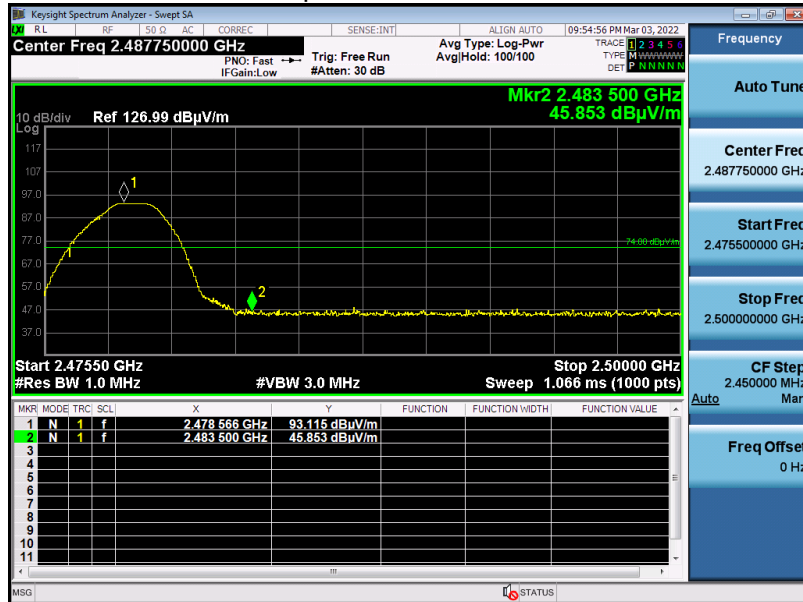

Test Graph for Average Measurement

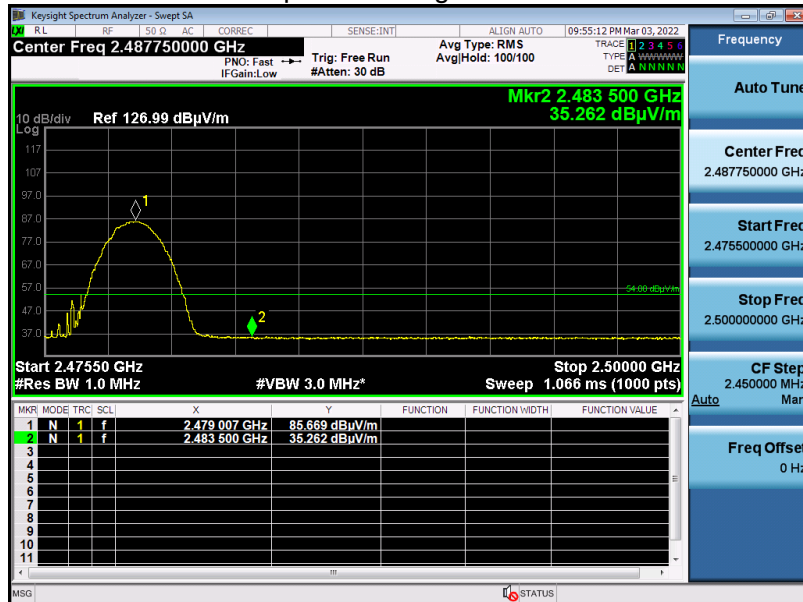

RESULT: PASS

EUT	2.4G keyboard	Model Name	E1050
Temperature	21.8° C	Relative Humidity	58%
Pressure	960hPa	Test Voltage	Normal Voltage
Test Mode	Mode 3	Antenna	Vertical

Test Graph for Peak Measurement

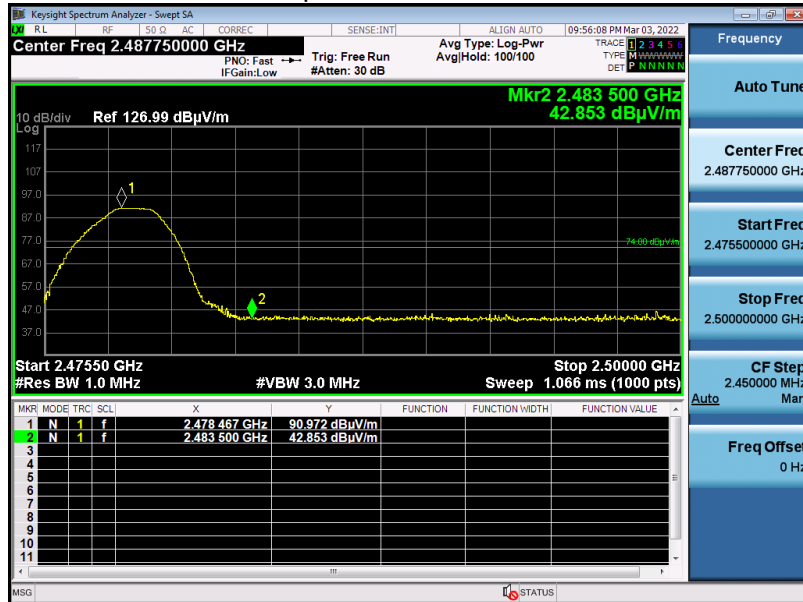

Test Graph for Average Measurement

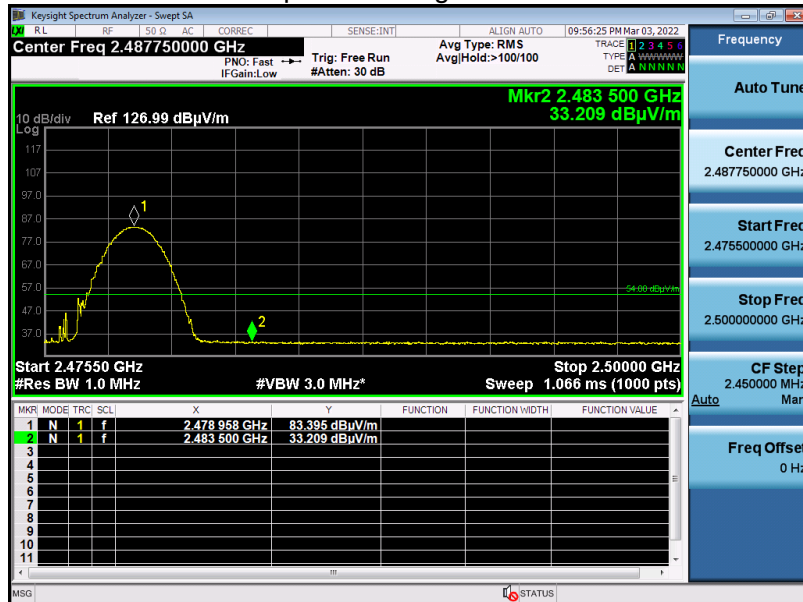

**RESULT: PASS**

Note: The factor had been edited in the "Input Correction" of the Spectrum Analyzer.



## 12. LINE CONDUCTED EMISSION TEST

### 12.1. LIMITS OF LINE CONDUCTED EMISSION TEST

Frequency	Maximum RF Line Voltage	
	Q.P.( dBuV)	Average( dBuV)
150kHz~500kHz	66-56	56-46
500kHz~5MHz	56	46
5MHz~30MHz	60	50

Note:

1. The lower limit shall apply at the transition frequency.
2. The limit decreases linearly with the logarithm of the frequency in the range 0.15 MHz to 0.50 MHz.

### 12.2. BLOCK DIAGRAM OF LINE CONDUCTED EMISSION TEST

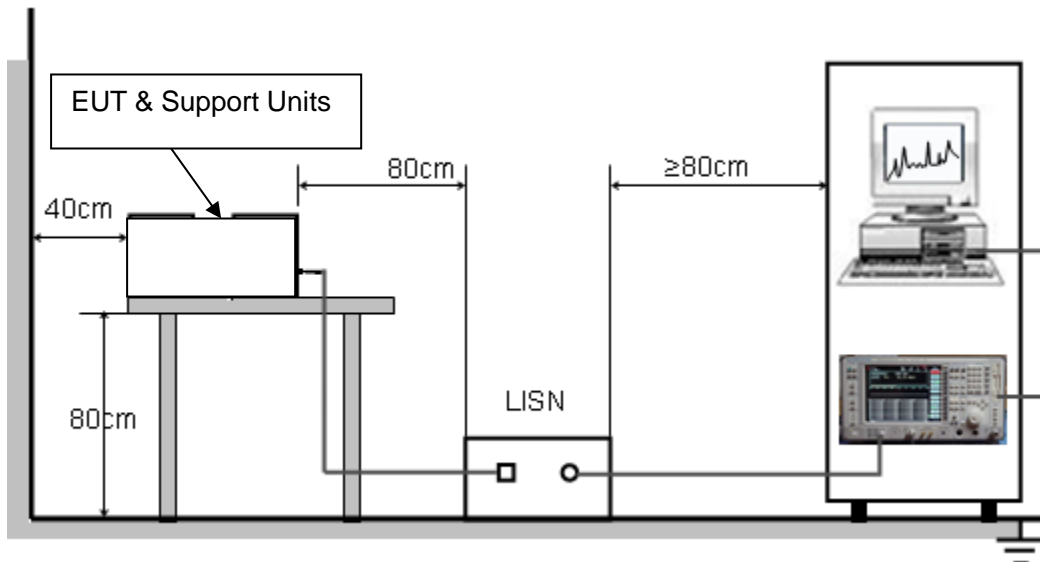

### **12.3. PRELIMINARY PROCEDURE OF LINE CONDUCTED EMISSION TEST**

1. The equipment was set up as per the test configuration to simulate typical actual usage per the user's manual. When the EUT is a tabletop system, a wooden table with a height of 0.8 meters is used and is placed on the ground plane as per ANSI C63.10 (see Test Facility for the dimensions of the ground plane used). When the EUT is a floor-standing equipment, it is placed on the ground plane which has a 3-12 mm non-conductive covering to insulate the EUT from the ground plane.
2. Support equipment, if needed, was placed as per ANSI C63.10.
3. All I/O cables were positioned to simulate typical actual usage as per ANSI C63.10.
4. All support equipment received AC120V/60Hz power from a LISN, if any.
5. The EUT received DC 5V power from adapter which received AC120V/60Hz power from a LISN.
6. The test program was started. Emissions were measured on each current carrying line of the EUT using a spectrum Analyzer / Receiver connected to the LISN powering the EUT. The LISN has two monitoring points: Line 1 (Hot Side) and Line 2 (Neutral Side). Two scans were taken: one with Line 1 connected to Analyzer / Receiver and Line 2 connected to a 50 ohm load; the second scan had Line 1 connected to a 50 ohm load and Line 2 connected to the Analyzer / Receiver.
7. Analyzer / Receiver scanned from 150 kHz to 30MHz for emissions in each of the test modes.
8. During the above scans, the emissions were maximized by cable manipulation.
9. The test mode(s) were scanned during the preliminary test.

Then, the EUT configuration and cable configuration of the above highest emission level were recorded for reference of final testing.

### **12.4. FINAL PROCEDURE OF LINE CONDUCTED EMISSION TEST**

1. EUT and support equipment was set up on the test bench as per step 2 of the preliminary test.
2. A scan was taken on both power lines, Line 1 and Line 2, recording at least the six highest emissions. Emission frequency and amplitude were recorded into a computer in which correction factors were used to calculate the emission level and compare reading to the applicable limit. If EUT emission level was less – 2dB to the A.V. limit in Peak mode, then the emission signal was re-checked using Q.P and Average detector.
3. The test data of the worst case condition(s) was reported on the Summary Data page.

### **12.5. TEST RESULT OF LINE CONDUCTED EMISSION TEST**

N/A

Note: The EUT is battery operated without AC mains.

**APPENDIX A: PHOTOGRAPHS OF TEST SETUP**

Refer to the Report No.: AGC00569220202AP01

**APPENDIX B: PHOTOGRAPHS OF EUT**

Refer to the Report No.: AGC00569220202AP02

**----END OF REPORT----**