



Test Report

Test Report Identifier:

SC-1137-155-01

Tested Device:

Wideband bodypack transmitter - WisyCom MTP40S-USX

According to the standards:

OET BULLETIN 65 Ed. 97-01 - Supplement C Ed. 01-01

Additional Information for Evaluating Compliance of Mobile and Portable Devices with FCC Limits for Human Exposure to Radiofrequency Emissions

IEEE1528-2003

Recommended Practice for Determining the Peak Spatial-Average SAR from Wireless Communications Devices: Measurement Techniques

Sicom test s.r.l. - AREA Science Park - Padriciano 99 - I-34149 Trieste – Italy
Web: www.sicomtesting.com - Tel: +39 0481 060474 - Email: sales@sicomtesting.com
Accredited by Ministero dello Sviluppo Economico



1. General information

Customer	
Company name	WISYCOM SRL
V.A.T. number	IT 02765640244
Address	Via Spin, 156
City	Romano d'Ezzelino (VI)
Postal Code	36060
Country	Italy
Telephone number	+39.0424.382605
Contact person name	Enzo Frigo
Contact person e-mail	efrigo@wisyc.com

Product Identification	
Device type (brief description)	Wideband bodypack transmitter
Trademark / Brand	WISYCOM SRL / WisyCom
Model name	MTP40S-USX
Hardware version	1
Software / Firmware version(s)	1

Test Standard: OET BULLETIN 65 Ed. 97-01 - *Supplement C Ed. 01-01 Additional Information for Evaluating Compliance of Mobile and Portable Devices with FCC Limits for Human Exposure to Radiofrequency Emissions.*

IEEE 1528-2003 - *IEEE Recommended Practice for Determining the Peak Spatial-Average Specific Absorption Rate (SAR) in the Human Head from Wireless Communications Devices: Measurement Techniques.*

FCC Title 47 §2.1093 - *Radiofrequency radiation exposure evaluation: portable devices*

KDB 865664 D01 v01r03 - *SAR Measurement for 100 MHz to 6 GHz*

KDB 447498 D01 v05r02 - *Mobile and Portable Devices RF Exposure Procedures and Equipment Authorization Policies - General RF Exposure Guidance*

The test results of this report relate only to the tested sample identified in this report.

Tested Devices:

Sample A: Serial number: T2142622; band: 470-640 MHz
Sample B: Serial number: T2142623; band: 510-698 MHz
Supported mode: FM (Peak deviation = ± 56 kHz)
Supported band: 470-698 MHz
Type of antenna: fixed
Power class: declared 100mW ERP

Date of Report: 18 June 2014

Test site: Sicom test s.r.l - AREA Science Park
Padriciano 99 - I-34149 Trieste Italy

Total number of pages: 50

This test report includes the following sections:

1. General information
2. Photographs
3. Test description
4. Test equipment and test conditions
5. System validation check data
6. Test results
7. Evaluation
8. Uncertainty evaluation
9. System validation check uncertainty
10. Annex A: Electric field probe calibration report
11. Annex B: dipoles reference SAR value and calibration

Test Operator: Antonio Dieni

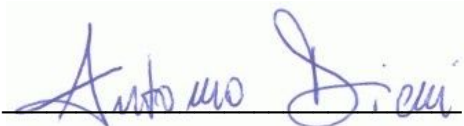

Technical responsible: Roberto Passini

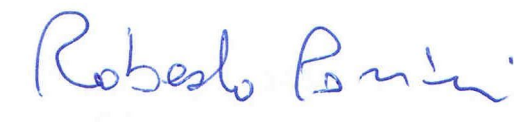

2. Photographs



Figure 1 – Tested Device during test



Figure 2 – Tested Device position: with the back side against the phantom



Figure 3 – Tested Device position: with the back side against the phantom (detail)

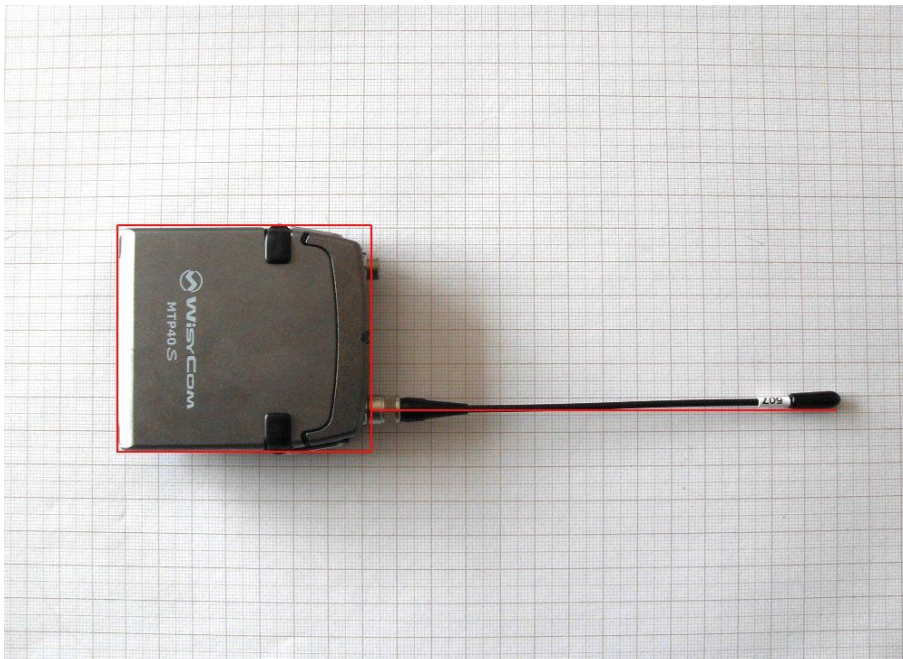

in all positions the marked center of the device
(center of antenna connector) coincides with the center of the shell
Figure 4 – device positioning for peak SAR locations

3. Test description

Scope, references and evaluation of compliance to the limits

This report contains the results of the measurements performed on the DUT described in the General Information section in order to evaluate its compliance to the basic restrictions related to human exposure to radio frequency electromagnetic fields, according to the recommended test positions for body worn and other configurations included in the OET BULLETIN 65 Ed. 97-01 - Supplement C Ed. 01-01 "Evaluating Compliance with FCC (Federal Communications Commission) Guidelines for Human Exposure to Radiofrequency Electromagnetic Fields - Additional Information for Evaluating Compliance of Mobile and Portable Devices with FCC Limits for Human Exposure to Radiofrequency Emissions".

The exposure limits, applied in U.S., for general population/uncontrolled exposure are specified inside the OET BULLETIN 65 Ed. 97-01 - Supplement C Ed. 01-01, Appendix A. Partial body SAR is averaged over any 1 gram of tissue defined as a tissue volume in the shape of a cube.

The results of measurements are compared directly to the limits and the DUT is declared to fulfill the requirements of the standard if the measured values are less than or equal to the limits.

The Dosimetric Assessment System

The SAR Dosimetric Assessment System used is able to determine the SAR distribution inside a phantom conforming to the European and U.S. standards. It consists of a robot, a field probe calibrated for use in liquids, a twin phantom, a flat phantom, a flat ellipsoidal phantom, a tissue simulating liquid, a mobile phone holder and software. The software controls the robot and processes the measured data to compare them to the limits.

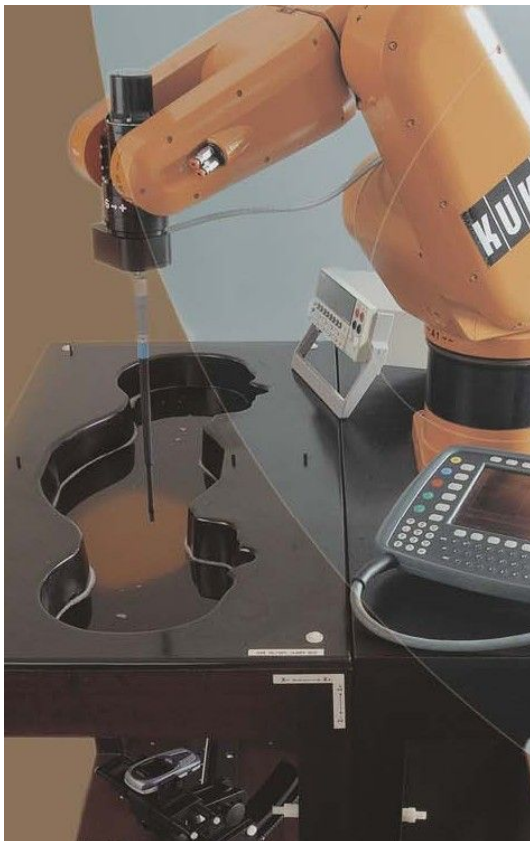

Picture A - SAR Dosimetric Assessment System

The twin phantom is a shell made with low loss and low permittivity material integrated in a wooden table. The shape of the shell is based on data from an anthropomorphic study and resembles the head and neck of a user, with average size and dimensions. The shell enables the dosimetric evaluation of left and right hand phone usage together with body-worn phone usage through the flat part of the phantom. A fully flat ellipsoidal phantom made with low loss and low permittivity material is used for dosimetric evaluation of body-worn usage of devices with bigger dimensions.

The E-field probe is a 3-axis system made of 3 distinct dipoles. It has a triangular section bar and on each face a dipole and a resistive line are located. The three orthogonal dipoles are linked to special Schottky diodes with low detection thresholds. The probe is designed to fulfill CENELEC and IEEE recommendations for the measurement of electromagnetic fields radiated by mobile phones, base stations and all radiating devices.

The mobile positioning device is made of low-loss and low permittivity material.

SAR measurement procedure

The dielectric properties of the tissue equivalent liquids are measured prior to the SAR measurements and at the same temperature with a tolerance of $\pm 2^{\circ}\text{C}$. The measured values are the permittivity ϵ and the electric conductivity σ and they shall comply with the values defined at the specific frequencies into the standard for body simulating tissue liquids with the tolerance of $\pm 5\%$.

A performance check is made before the DUT SAR measurements in order to verify that the system operates within its specifications. It is a 10 g averaged SAR measurement using a simplified set-up with a dipole source. The components and procedures in the simplified performance check are the same as those used for the compliance tests. The result of this check shall be within $\pm 10\%$ of the target value, determined during the system validation check.

During all the tests is monitored ambient temperature of the laboratory and liquid, relative humidity and the liquid depth is above 15 cm in all cases.

The tested device uses its internal transmitter; the antenna(s), battery and accessories are those specified by the manufacturer. The battery is fully charged before each measurement and there are no external connections.

The output power and frequency are controlled using a network emulator. The device is set to transmit at its highest output peak power level on the required frequencies of each transmitting band.

The device is tested in the body-worn operating configurations, with the belt clips and holsters attached to the device and positioned against a flat phantom in normal use configuration. Devices with a headset output are tested with a headset connected to the device.

Both the physical spacing to the body of the user as dictated by the accessory and the materials used in an accessory affect the SAR produced by the transmitting device.

When multiple accessories that do not contain metallic components are supplied with the device, the device is tested with only the accessory that dictates the closest space to the body.

When multiple accessories that contain metallic components are supplied with the device, the device is tested with each accessory that contain a unique metallic component. If multiple accessories share an identical metallic component, only the accessory that dictates the closest spacing to the body must be tested. Body-worn accessories may not always be supplied or available as options for some devices that are intended to be authorized for body-worn use. A separation distance between the back of the device and the flat phantom is used for testing body-worn SAR compliance under such circumstances.

If the mobile phone has a retractable antenna, all of the tests are performed both with the antenna fully extended and fully retracted.

From measured data the average SAR, in a volume in the shape of a cube and side dimension of a 1g and 10g of tissue, is calculated and compared to the limits.

Spatial Peak SAR, resolution, volume or zoom scan procedure

The system software includes all numerical procedures necessary to evaluate the spatial peak SAR values.

The spatial-peak SAR can be computed over any required mass. The base for the evaluation is a "cube" measurement in a volume of 30mm^3 ($7 \times 7 \times 7$ points, $dx=5\text{mm}$, $dy=5\text{mm}$, $dz=5\text{mm}$). The measured volume includes the 1g and 10g cubes with the highest averaged SAR values. For that purpose, the center of the measured volume is aligned to the interpolated peak SAR value of a previously performed area scan. The entire evaluation of the spatial peak values is performed within the post-processing engine. The system always gives the maximum values for the 1g and 10g cubes. The algorithm to find the cube with highest averaged SAR is divided into the following stages:

1. Extraction of the measured data (grid and values) from the Zoom Scan
2. Calculation of the SAR value at every measurement point based on all stored data (A/D values and measurement parameters)
3. Generation of a high-resolution mesh within the measured volume
4. Interpolation of all measured values from the measurement grid to the high-resolution grid
5. Extrapolation of the entire 3-D field distribution to the phantom surface over the distance from sensor to surface
6. Calculation of the averaged SAR within masses of 1g and 10g

Description of interpolation/extrapolation scheme

The local SAR inside the phantom is measured using small dipole sensing elements inside a probe body. The probe tip must not be in contact with the phantom surface in order to minimise measurements errors, but the highest local SAR will occur at the surface of the phantom.

An extrapolation is used to determinate this highest local SAR values. The extrapolation is based on a fourth-order least-square polynomial fit of measured data. The local SAR value is then extrapolated from the liquid surface with a 1 mm step.

The measurements have to be performed over a limited time (due to the duration of the battery) so the step of measurement is high. It could vary between 5 and 8 mm. To obtain an accurate assessment of the maximum SAR averaged over 10 grams and 1 gram requires a very fine resolution in the three dimensional scanned data array.

An interpolation is used to provide an array of sufficient resolution. The measured and extrapolated SAR values are interpolated on a 1 mm grid with a three dimensional thin plate spline algorithm.

SAR measurement system technical data: phantom description

The SAM phantom is delivered with a CAD CD-ROM including the 3D data of the internal shape of the shell. These data are used by the 6 axis robot control software to define movements relative to its internal surface through 5 additional CAD-linked reference points.

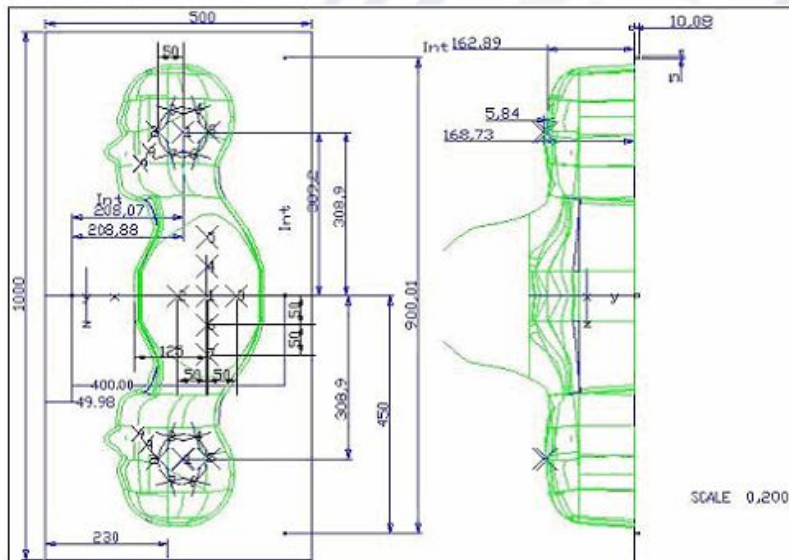

Picture B – SAM and ellipsoidal shell

SAM shell technical data:

Shell thickness	2 mm ± 0.2 mm
Permittivity / loss tangent	3.3 / 0.017
Filling phantom volume/ liquid depth	27 litres / 20 cm

Dimensions	1000 mm (length) x 500 mm (width) x 200 mm (height)
References	IEEE 1528-2003, CENELEC 50361 and IEC 62209-1

Ellipsoidal shell technical data:

Shell thickness	2 mm ± 0.2 mm
Permittivity / loss tangent	4.4 / 0.017
Filling Volume	35 litres / 20 cm
Dimensions	800 mm (length) x 500 mm (width) x 200 mm (height)
References	IEC 62209-2

SAR measurement system technical data: device holder

The SAR in the phantom is approximately inversely proportional to the square of the distance between the source and the liquid surface. For a source in 5mm distance, a positioning uncertainty of ±0.5mm would produce a SAR uncertainty of ±20%. An accurate device positioning is therefore crucial for accurate and repeatable measurements.

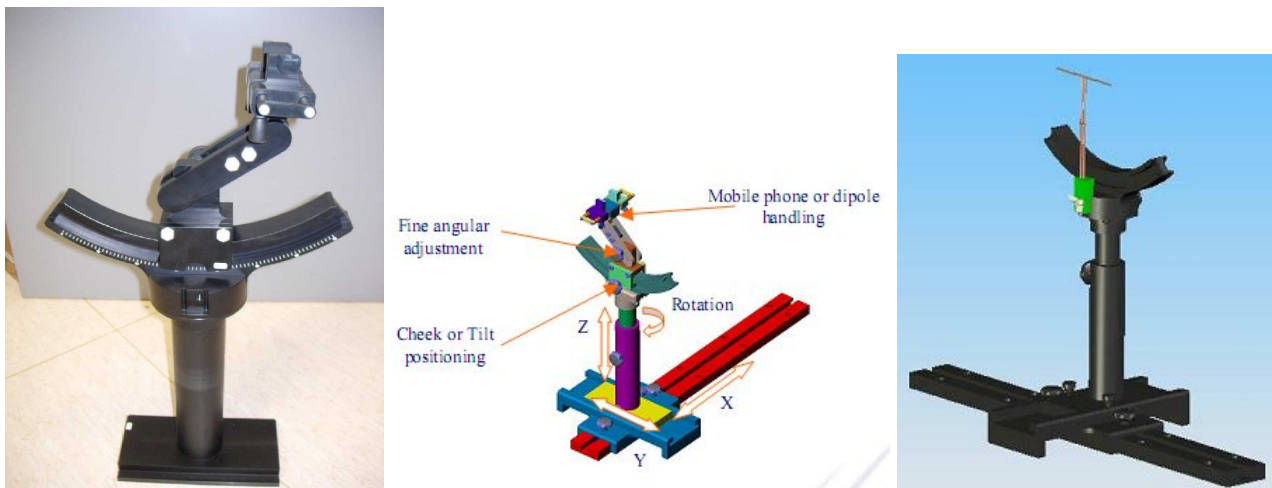

Picture C – positioning holder overview

Device holder system characteristics:

General	Totally metal-free design. Three graduated translation and five rotation point to lock the device under test under the flat part or under the left or right ear. Ensured repeatability with fine angular adjustment. Mobile phone or dipole handling.
Permittivity / loss tangent	3.0 / 0.017
Material	POM
X translation	700 mm
Y translation	250 mm
Z translation	100 mm

SAR measurement system technical data: isotropic E-Field Probe

Probes are constructed with a triangular section bar in alumina. On each face, a dipole and a resistive line are printed. A Schottky diode is placed in the center of each dipole. Symmetrical design with triangular core. These uncoupled dipoles perform the isotropic and wide-band measurements. See Annex A for calibration.



Picture D – isotropic E-Field Probe

isotropic E-Field Probe technical data:

Frequency range	100 MHz - 30 GHz
Length	330 mm
Dipoles Length	4.5 mm
Maximum external diameter	8 mm
Probe tip external diameter	5 mm
Distance between dipoles and the probe tip	<2.7mm
Dipole resistance (in the connector plane)	1MΩ to 2MΩ
Axial isotropy in human-equivalent liquids	± 0.2 dB
Hemispherical Isotropy in human-equivalent liquids	± 0.3 dB
Linearity	± 0.5 dB
Maximum operating SAR	100 Watts/kg
Lower SAR detection threshold	0.0015 Watts/kg
Connectors	6 male wires (Hirose SR30)

SAR measurement system technical data: reference dipoles

The antennas are developed with a $\lambda/4$ balun, so that all calibration dipoles are totally symmetrical. Each validation dipole is used to check the whole SAR measurement chain in its frequency band. They are especially developed to make SAR measurements near a flat SAM phantom filled with human-equivalent liquid, according to CENELEC and IEEE standards. Each dipole has been designed to be plugged in the device holder positioning system. See Annex A for calibration.

Reference dipoles technical data:

Frequencies	450, 900, 1800, 2000, 2450 MHz
Adaptation	S11 < -20dB in specified validation position.
Power	100W
Connectors	SMA
Dimensions	Height : between 200 mm and 300 mm Length : between 25 mm and 83 mm depends on the dipole frequency

4. Test equipment and test conditions

Test Equipment:

SAR Dosimetric Assessment System - Manufacturer: Satimo Model: COMOSAR TWINS

Instrument Type	Model	Manufacturer	Serial Number	Calibration periodicity	Last Calibration
Robot	KR3	Kuka	846427	N.S.	-
Robot Remote Controller	KRC3	Kuka	599	N.S.	-
Robot Control Panel	KCP2	Kuka	1438	N.S.	-
Isotropic E-field probe	---	Satimo	SN 46/06 EP60	12 months	26/02/2014
Dipole	450 MHz	Satimo	SN 39/05 DIPB26	24 months	21/02/2014
SAM shell	Twins phantom	Satimo	SN 39/05 SAM26	N.S.	-
Flat shell	Flat phantom	Satimo	SN 39/05 FVA11	N.S.	-
Flat ellipsoidal shell	Flat shell ellipsoidal	Satimo	SN 46/07 ELLI13	N.S.	-
Positioning system	---	Satimo	SN 39/05 MSH13	N.S.	-
Open coaxial probe	---	Satimo	SN 39/05 OCP8	36 months	26/02/2014
Liquid body	450 MHz	Satimo	--	every test session	-

Supporting test equipment

Instrument Type	Model	Manufacturer	Serial Number	Calibration periodicity	Last Calibration
Multimeter	Mod. 2000	Keithley	1062722	18 months	19/02/2014
Power amplifier	RF 4002000-2	RFPA	52627	N.S.	-
Signal Generator	SMIQ03B	Rohde & Schwarz	831389/028	24 months	11/03/2014
Power meter	NRVS	Rohde & Schwarz	827023/049	24 months	11/03/2014
Sensor head	NRV-Z51	Rohde & Schwarz	829759/003	24 months	11/03/2014
Directional coupler	ZFDC-20-5	Minicircuits	--	24 months	11/03/2014
Directional coupler	R433563000	Radiall	--	24 months	11/03/2014
Vector Network Analyser	MS4622B	Anritsu	984502	24 months	24/02/2014
Digital Spectrum Analyzer / Radio Transmitter Tester	MS8609A	Anritsu	6200456808	12 months	12/03/2014

Test Conditions:

The testing has been performed within the period:

From: 12 June 2014
To: 16 June 2014

Ambient Conditions:

Temperature: $+22^{\circ}\text{C} \pm 2^{\circ}\text{C}$

Tested device conditions:

Modulation: FM (Peak deviation = ± 56 kHz).
Antenna: Fixed external (screwed on LEMO RF connector).
Accessories: Microphone.
Configurations: With microphone (the only user configuration possible).
Power supply: Full charge alkaline battery (2 x 1,5V AA) every SAR measurement.
RF power: The device is set to transmit at its highest output peak power level with a continuous transmission (100 has been set of the values 100, 50, 10 mW power settings).
Positioning: The device is tested in the body-worn operating configurations with a separation distance of **0 cm** between the device and the flat phantom with the back side (belt clip) against the phantom. A foam spacer were used to keep antenna straight.

SAR test reduction considerations:

According to the KDB 447498 D01 v05r02 the § 4.3.3 test reduction were applied:

Testing of other required channels within the operating mode of a frequency band is not required when the reported 1-g or 10-g SAR for the mid-band or highest output power channel is:³²

- ≤ 0.8 W/kg or 2.0 W/kg, for 1-g or 10-g respectively, when the transmission band is ≤ 100 MHz
- ≤ 0.6 W/kg or 1.5 W/kg, for 1-g or 10-g respectively, when the transmission band is between 100 MHz and 200 MHz
- ≤ 0.4 W/kg or 1.0 W/kg, for 1-g or 10-g respectively, when the transmission band is ≥ 200 MHz

Then being the reported SAR below 0.6 W/Kg in the range 470-608 MHz and below 0.8 W/Kg in the range 614-698 MHz the test reduction in the second and first dot respectively has been applied, taking into account the conducted measurements.

Exposure limit applied:

Limit for General population/Uncontrolled exposure
Spatial Peak (averaged over any 1g of tissue) limit: **1.6 W/Kg**

Reported SAR:

Reported SAR is scaled to the maximum tune-up tolerance limit declared by the manufacturer by the following formula:

Reported SAR = Maximum tune-up tolerance limit [mW] / Measured maximum power [mW] * Measured SAR

were the Declared maximum tune-up tolerance limit = 110 mW.

Note: the samples used for the SAR test is within the tune-up tolerance but not more than 2 dB lower than the maximum tune-up tolerance limit.

5. System validation check data

Measurement for Tissue Simulant Liquid

Tissue dielectric property measurement procedure: contact probe

The measurement is performed using a calibration kit (pre-calibrated open coaxial probe, pre-calibrated cable, and vector network analyzer as detailed in Test Equipment section of this Report) to determinate the S₁₁ parameters of the tissue simulant liquid. The system software is able to calculate the complex permittivity (i.e. ϵ and σ) of the liquid in the frequency band of 300 MHz to 3 GHz. Steps of the permittivity measurement: 1) SOL (Short, Open and Load) calibration at the end of the cable; 2) measurement of the S₁₁ parameters of known reference fluid (pure water) at known temperature; 3) measurement of the S₁₁ parameters of Tissue Simulant Liquid. The tests were conducted on the same days as the measurement of the EUT.



Picture E: open coaxial probe with the bottle cap

Dielectric properties measured:

The conductivity σ and permittivity ϵ_r are listed in table below for the SAR measurement given in this report and were verified to be within a tolerance of $\pm 5\%$ from the target values:

Date of measurement: 16 June 2014; Temperature: 22.6°C.

Band	Tissue Type	Frequency	Values*	ϵ_r relative permittivity	σ conductivity (S/m)
450 MHz	Body	450.0 MHz	Target value	56.7	0.94
			$\pm 5\%$ range	53.865 - 59.535	0.893 - 0.987
			Measured	56.51	0.944
450 MHz	Body	470.0 MHz	Target value	56.622	0.942
			$\pm 5\%$ range	53.790 - 59.453	0.895 - 0.989
			Measured	56.18	0.950
450 MHz	Body	614.0 MHz	Target value	56.061	0.953
			$\pm 5\%$ range	53.258 - 58.864	0.905 - 1.000
			Measured	55.94	0.957

* target values from KDB 865664 D01 v01r03.

SAR system verification

SAR measurement system verification procedure

The microwave circuit arrangement for system verification is showed in the bottom picture. Instruments and reference dipoles detailed in Test Equipment section of this Report. The tests were conducted daily on the same days as the measurement of the EUT. Steps of the measurement: 1) a CW power level of **1 W** at the same frequency of the reference dipole is measured in the point A; 2) this power level is input to the reference dipole positioned (through a calibrated jig) at the center of the flat section of the SAM phantom (or at the center of ellipsoidal shell) and a SAR measurement was performed to verify if the measured SAR was within +/- 10% from the target reference SAR values.

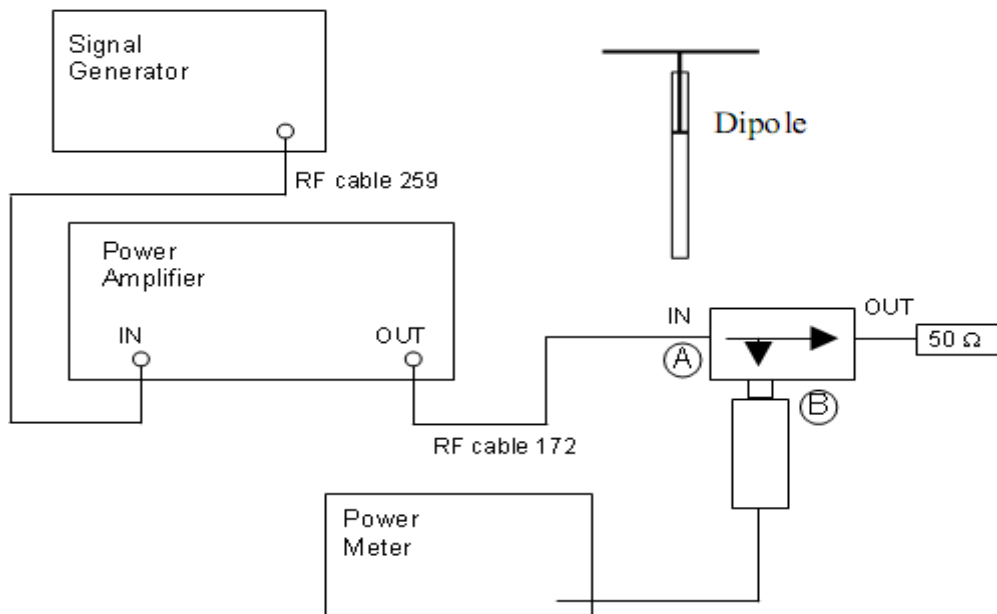

Picture F: system verification scheme

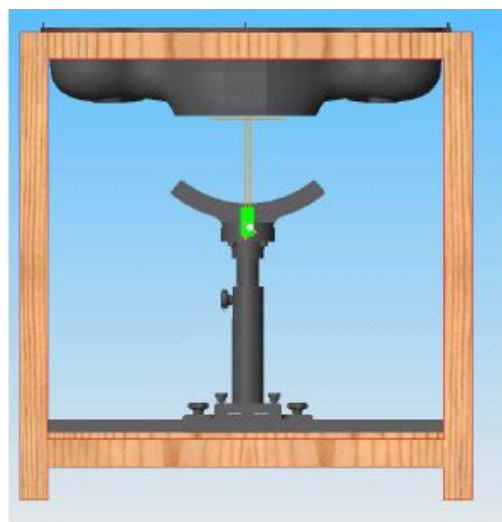

Picture G: reference dipole position for system verification

VALIDATION 1

Type: Dipole measurement (Complete)
Date of measurement: 16/06/2014

A. Experimental conditions.

Phantom	Flat ellipsoidal shell
Device Position	Dipole
Band	450
Channel	Middle
Signal	CW (Duty Cycle: 1:1)
Dipole input power	1 W
Probe	EP60
Probe Path	Adaptative 1 max
Liquid Temperature	22.7 °C

B. SAR Measurement Results

Frequency (MHz)	450.0
Relative permittivity (real part)	56.51
Conductivity (S/m)	0.944
Maximum location	X=-6.00, Y=8.00

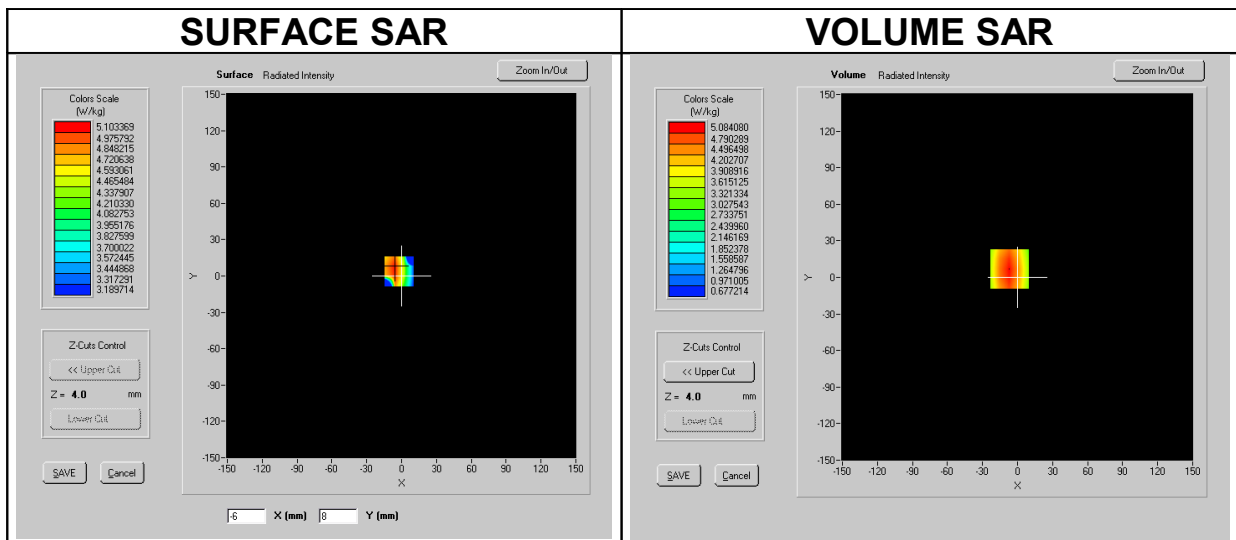

SAR	SAR (W/kg)	Target value* (W/kg)	Variation (%)
SAR 1g	5.018	5.05	-0.6

* target value from manufacturer calibration dipole SAR.

6. Test results

RF conducted power

EUT RF power setting: 100 mW.

EUT Modulation: FM.

Measurement with: Spectrum analyzer, 10 dB RF attenuator, LEMO adapter

Band (MHz)	Frequency (MHz)	Conducted power (dBm)	Conducted power (mW)
470-698 MHz	470	19.84	96.38
	498.5	19.84	96.38
	527	19.62	91.62
	555.5	19.49	89.10
	584	19.47	88.51
	612.5	19.38	86.69
	614	19.34	85.90
	641	19.12	81.65
	669.5	19.01	79.61
	698	19.10	81.28

MEASUREMENT 1

Type: Phone measurement (Complete)

Date of measurement: 16/06/2014

Tested device serial number: T2142622

A. Experimental conditions.

Phantom	Flat ellipsoidal shell
Device Position	Body Worn
Antenna Position	Fixed
Band	470-698 MHz
Channel	470.0 MHz
Transmission mode	FM
Signal	CW (Duty Cycle: 1:1)
EUT Position	With the back side against the phantom
Probe Path	Flat
Distance	d=0.0 cm (clip)
Probe	EP60

B. SAR Measurement Results

Frequency (MHz)	470.0
Relative permittivity (real part)	56.18
Conductivity (S/m)	0.950
Battery Power drift	-0.02 %
Maximum location	X=-6.00, Y=56.00

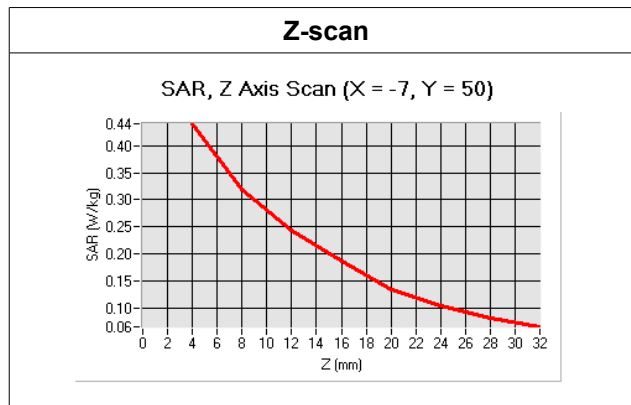
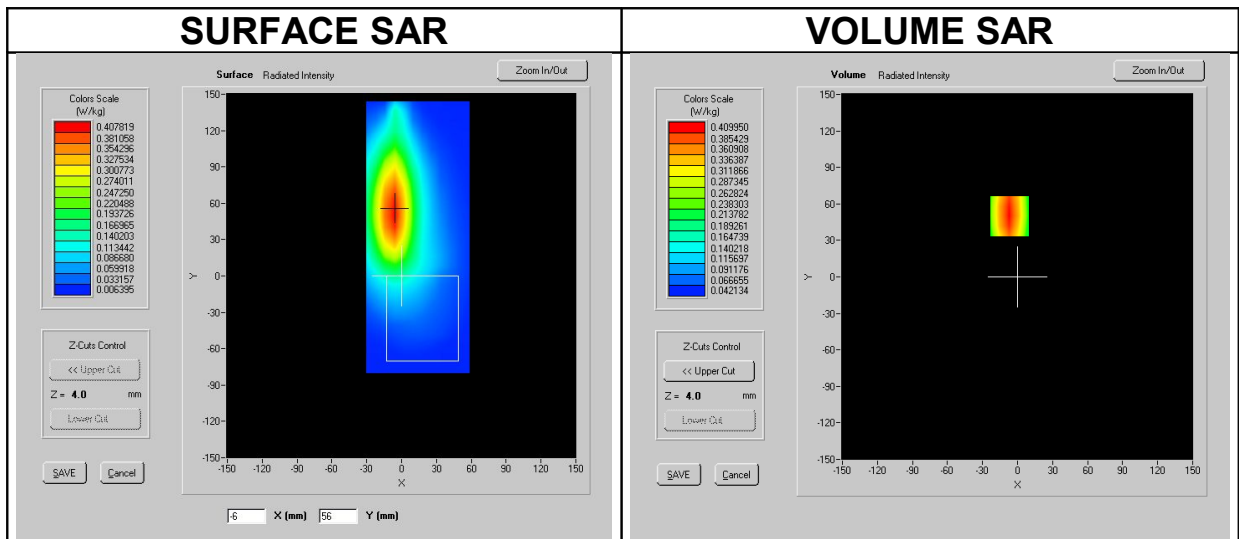

SAR	Measured SAR (W/kg)	Reported SAR (W/kg)	Limit (W/kg)	Result
SAR 1g	0.418	0.477	1.600	PASS

Maximum tune-up tolerance limit [mW] / Measured maximum power [mW] = 110 mW / 96.38 mW = 1.141

MEASUREMENT 2

Type: Phone measurement (Complete)

Date of measurement: 16/06/2014

Tested device serial number: T2142623

A. Experimental conditions.

Phantom	Flat ellipsoidal shell
Device Position	Body Worn
Antenna Position	Fixed
Band	470-698 MHz
Channel	614.0 MHz
Transmission mode	FM
Signal	CW (Duty Cycle: 1:1)
EUT Position	With the back side against the phantom
Probe Path	Flat
Distance	d=0.0 cm (clip)
Probe	EP60

B. SAR Measurement Results

Frequency (MHz)	614.0
Relative permittivity (real part)	55.94
Conductivity (S/m)	0.957
Battery Power drift	-0.48 %
Maximum location	X=-6.00, Y=56.00

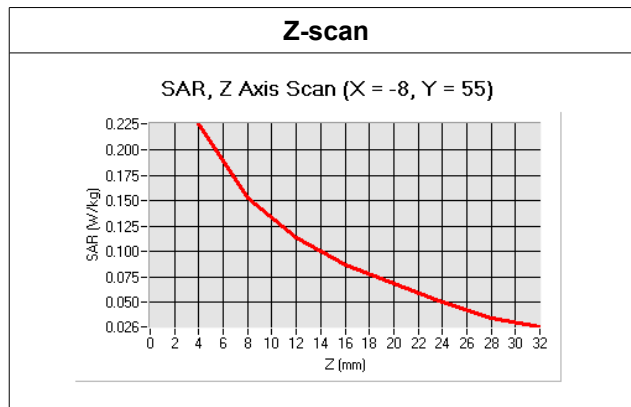
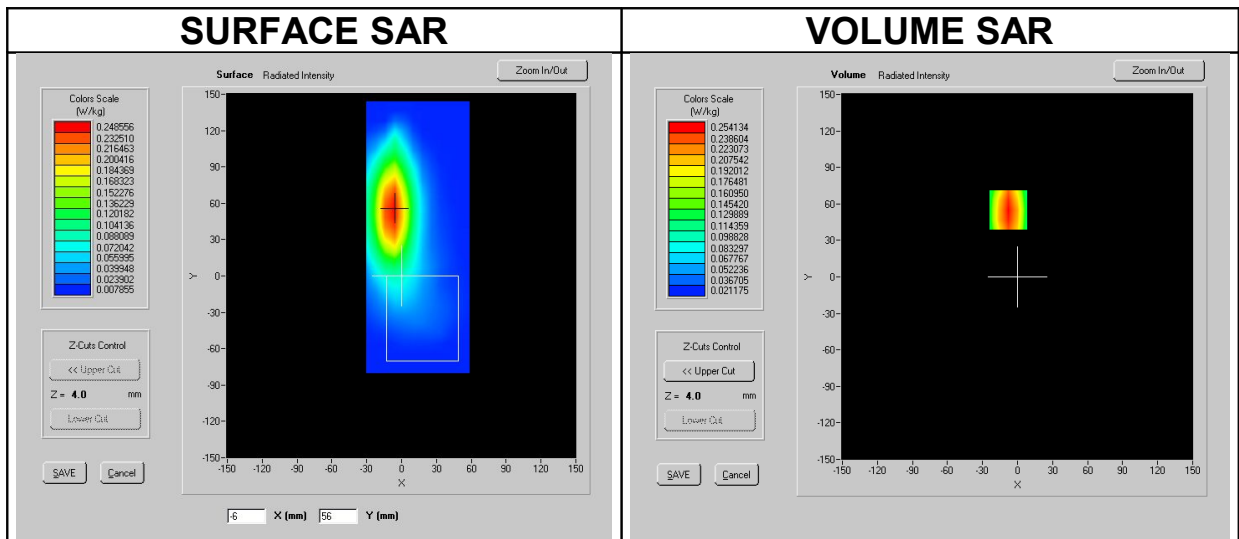

SAR	Measured SAR (W/kg)	Reported SAR (W/kg)	Limit (W/kg)	Result
SAR 1g	0.218	0.279	1.600	PASS

Maximum tune-up tolerance limit [mW] / Measured maximum power [mW] = 110 mW / 85.90 mW = 1.280

7. Evaluation

In the following table the SAR results for the tested device are summarized.

Band	Frequency	Mode	Phantom	EUT position	Antenna	Measured SAR 1g (W/kg)	Reported SAR 1g (W/kg)
470-698 MHz	470.0 MHz	FM Max power setting 100 mW	flat ellipsoidal	With the back side against the phantom	fixed	0.418	0.477
470-698 MHz	614.0 MHz	FM Max power setting 100 mW	flat ellipsoidal	With the back side against the phantom	fixed	0.218	0.279

The maximum Specific Absorption Rate (SAR) averaged over 1 g, determined at 470.0 MHz frequency in FM mode, of the Wideband bodypack transmitter WisyCom MTP40S-USX portable unit, is **0.477 W/kg**.

The overall margin of uncertainty for these measurements is given at the Uncertainty evaluation section.

The SAR 1g exposure limit applied, in the OET BULLETIN 65 Ed. 97-01 - Supplement C Ed. 01-01 for Partial body exposure is **1.6 W/kg**.

This unit as tested is found to be **COMPLIANT** with these requirements.

8. Uncertainty evaluation

Below the contributions of each component of uncertainty is reported together with its name, probability distribution, sensitivity coefficient and uncertainty value. The results are recorded in a table and the combined uncertainty is given, as required by the standards.

UNCERTAINTY EVALUATION FOR HANDSET SAR TEST									
a	b	c	d	e= f(d,k)	f	g	h= cx/f/e	i= cxg/e	k
Uncertainty Component	Sec.	Tol. (± %)	Prob. Dist.	Div.	c_i (1 g)	c_i (10 g)	1 g u_i (± %)	10 g u_i (± %)	v_i
Measurement System									
Probe Calibration	E.2.1.	7	N	1	1	1	7	7	∞
Axial Isotropy	E.2.2.	2,5	R	$\sqrt{3}$	$(1-c_p)^{1/2}$	$(1-c_p)^{1/2}$	1,02062	1,02062	∞
Hemispherical Isotropy	E.2.2.	4	R	$\sqrt{3}$	$\sqrt{c_p}$	$\sqrt{c_p}$	1,63299	1,63299	∞
Boundary Effect	E.2.3.	1	R	$\sqrt{3}$	1	1	0,57735	0,57735	∞
Linearity	E.2.4.	5	R	$\sqrt{3}$	1	1	2,88675	2,88675	∞
System Detection Limits	E.2.5.	1	R	$\sqrt{3}$	1	1	0,57735	0,57735	∞
Readout Electronics	E.2.6.	0,02	N	1	1	1	0,02	0,02	∞
Response Time	E.2.7.	3	R	$\sqrt{3}$	1	1	1,73205	1,73205	∞
Integration Time	E.2.8.	2	R	$\sqrt{3}$	1	1	1,1547	1,1547	∞
RF Ambient Conditions	E.6.1.	3	R	$\sqrt{3}$	1	1	1,73205	1,73205	∞
Probe Positioner Mechanical Tolerance	E.6.2.	2	R	$\sqrt{3}$	1	1	1,1547	1,1547	∞
Probe Positioning with respect to Phantom Shell	E.6.3.	0,05	R	$\sqrt{3}$	1	1	0,02887	0,02887	∞
Extrapolation, interpolation and Integration Algorithms for Max. SAR Evaluation	E.5.2.	5	R	$\sqrt{3}$	1	1	2,88675	2,88675	∞
Test sample Related									
Test Sample Positioning	E.4.2.1.	0,03	N	1	1	1	0,03	0,03	N-1
Device Holder Uncertainty	E.4.1.1.	5	N	1	1	1	5	5	N-1
Output Power Variation - SAR drift measurement	6.6.2.	3	R	$\sqrt{3}$	1	1	1,73205	1,73205	∞
Phantom and Tissue Parameters									
Phantom Uncertainty (shape and thickness tolerances)	E.3.1.	0,05	R	$\sqrt{3}$	1	1	0,02887	0,02887	∞
Liquid Conductivity - deviation from target values	E.3.2.	5	R	$\sqrt{3}$	0,64	0,43	1,84752	1,2413	∞
Liquid Conductivity - measurement uncertainty	E.3.3.	5	N	1	0,64	0,43	3,2	2,15	M
Liquid Permittivity - deviation from target values	E.3.2.	3	R	$\sqrt{3}$	0,6	0,49	1,03923	0,8487	∞
Liquid Permittivity - measurement uncertainty	E.3.3.	10	N	1	0,6	0,49	6	4,9	M
Combined Standard Uncertainty			RSS				11,1265	10,5799	
Expanded Uncertainty (95% CONFIDENCE INTERVAL)			k				21,8079	20,7366	

9. System validation check uncertainty

Below the contributions of each component of uncertainty is reported together with its name, probability distribution, sensitivity coefficient and uncertainty value. The results are recorded in a table and the combined uncertainty is given, as required by the standards.

UNCERTAINTY FOR SYSTEM PERFORMANCE CHECK									
a	b	c	d	e= f(d,k)	f	g	h= cxf/e	i= cxg/e	k
Uncertainty Component	Sec.	Tol. (± %)	Prob. Dist.	Div.	c_f (1 g)	c_g (10 g)	1 g u_i (± %)	10 g u_i (± %)	v_i
Measurement System									
Probe Calibration	E.2.1.	7	N	1	1	1	7	7	∞
Axial Isotropy	E.2.2.	2,5	R	$\sqrt{3}$	$(1-c_p)^{1/2}$	$(1-c_p)^{1/2}$	1,02062	1,02062	∞
Hemispherical Isotropy	E.2.2.	4	R	$\sqrt{3}$	$\sqrt{c_p}$	$\sqrt{c_p}$	1,63299	1,63299	∞
Boundary Effect	E.2.3.	1	R	$\sqrt{3}$	1	1	0,57735	0,57735	∞
Linearity	E.2.4.	5	R	$\sqrt{3}$	1	1	2,88675	2,88675	∞
System Detection Limits	E.2.5.	1	R	$\sqrt{3}$	1	1	0,57735	0,57735	∞
Readout Electronics	E.2.6.	0,02	N	1	1	1	0,02	0,02	∞
Response Time	E.2.7.	3	R	$\sqrt{3}$	1	1	1,73205	1,73205	∞
Integration Time	E.2.8.	2	R	$\sqrt{3}$	1	1	1,1547	1,1547	∞
RF Ambient Conditions	E.6.1.	3	R	$\sqrt{3}$	1	1	1,73205	1,73205	∞
Probe Positioner Mechanical Tolerance	E.6.2.	2	R	$\sqrt{3}$	1	1	1,1547	1,1547	∞
Probe Positioning with respect to Phantom Shell	E.6.3.	0,05	R	$\sqrt{3}$	1	1	0,02887	0,02887	∞
Extrapolation, interpolation and Integration Algorithms for Max. SAR Evaluation	E.5.2.	5	R	$\sqrt{3}$	1	1	2,88675	2,88675	∞
Dipole									
Dipole Axis to Liquid Distance	8, E.4.2.	1	N	$\sqrt{3}$	1	1	0,57735	0,57735	N-1
Input Power and SAR drift measurement	8, 6.6.2.	2	R	$\sqrt{3}$	1	1	1,1547	1,1547	∞
Phantom and Tissue Parameters									
Phantom Uncertainty (shape and thickness tolerances)	E.3.1.	0,05	R	$\sqrt{3}$	1	1	0,02887	0,02887	∞
Liquid Conductivity - deviation from target values	E.3.2.	5	R	$\sqrt{3}$	0,64	0,43	1,84752	1,2413	∞
Liquid Conductivity - measurement uncertainty	E.3.3.	5	N	1	0,64	0,43	3,2	2,15	M
Liquid Permittivity - deviation from target values	E.3.2.	3	R	$\sqrt{3}$	0,6	0,49	1,03923	0,8487	∞
Liquid Permittivity - measurement uncertainty	E.3.3.	10	N	1	0,6	0,49	6	4,9	M
Combined Standard Uncertainty				RSS			9,87239	9,25204	
Expanded Uncertainty (95% CONFIDENCE INTERVAL)				k			19,3499	18,134	

10. Annex A: Electric field probe calibration reports

	Bâtiment PONANT, Ave La Pérouse Zone du Technopole Brest Iroise, 29280 PLOUZANE. ☎ : +33 (0)2-98-05-13-34. ☎ : +33 (0)2-98-05-53-87.
---	---

COMOSAR SEPT ISOTROPIC E-FIELD PROBE CALIBRATION REPORT

DATE: 26/02/2014
REFERENCE: SN 46/06 EP60
OBJECT: COMOSAR SEPT ISOTROPIC E-FIELD PROBE
MANUFACTURER: SATIMO
SERIAL NUMBER: SN 46/06 EP60
CUSTOMER: SICOM
ORDER:
DATE OF CALIBRATION: 26/02/2014

WARRANTY:
This Calibration certificate may not be reproduced other than in full. Calibration certificates without signature and seal are not valid. This documentation contains property information which is protected by copyright. All right are reserved. No part of this document may be photocopied, reproduced without the prior written agreement of SATIMO. SATIMO shall not be liable for errors contained herein or for incidental or consequential in connection with the furnishing, performance or use of this material. Warranty doesn't apply to Normal wear, Normal tear, Improper use, Improper maintain, Improper installation.

Date	SEAL
COMOSAR PROJECT MANAGER	SATIMO Bâtiment PONANT Avenue La Pérouse Technopôle BREST IROISE 29280 PLOUZANE Tél. 02.98.05.13.34 - Fax 02.98.05.53.87



1

	Bâtiment PONANT, Ave La Pérouse Zone du Technopole Brest Iroise, 29280 PLOUZANE. ☎ : +33 (0)2-98-05-13-34. 📠 : +33 (0)2-98-05-53-87.
---	---

PRODUCT DESCRIPTION



Frequency Range	100 MHz - 30 GHz
Probe length	330 mm
Length of one dipole	4.5 mm
Maximum external diameter	8 mm
Probe extremity diameter	6.5 mm
Distance between dipoles/probe extremity	< 2.7 mm
Resistance of the three dipole (at the connector)	Dipole 1: R1=1.2306 MΩ Dipole 2: R2=1.0729 MΩ Dipole 3: R3=1.3666 MΩ
Connector (HIROSE series SR30)	6 wire male (Hirose SR30series)

The probe could be checked by measuring the resistance of the three dipoles.

CALIBRATION TEST EQUIPMENT

TYPE	IDENTIFICATION
Calibration bench	CALISAR
Multimeter	Keithley 2000

	Bâtiment PONANT, Ave La Pérouse Zone du Technopole Brest Iroise, 29280 PLOUZANE. ☎ : +33 (0)2-98-05-13-34. 📠 : +33 (0)2-98-05-53-87.
---	---

MEASUREMENT PROCEDURE

Probe calibration is realized, in compliance with CENELEC EN 50361 and IEEE 1528 std, with CALISAR, Satimo proprietary calibration system. The calibration is performed with the EN 50361 annex technique using reference guide at the five frequencies.

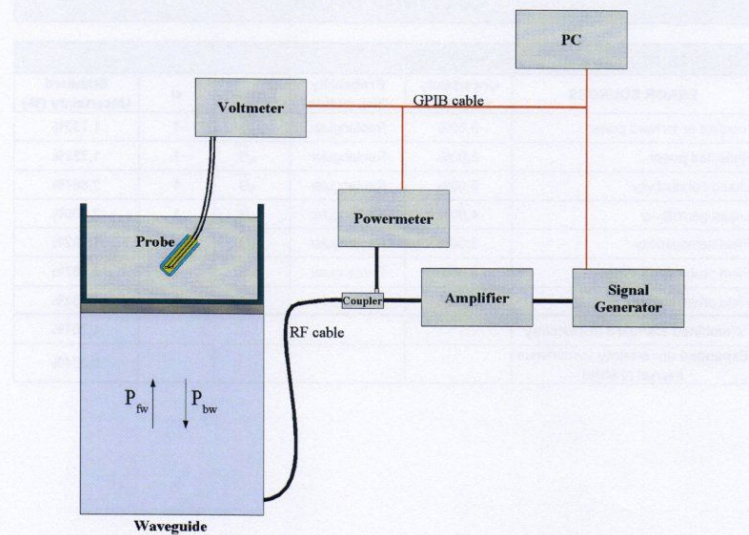

$$SAR = \frac{4(P_{fw} - P_{bw})}{ab\delta} \cos^2\left(\pi \frac{y}{a}\right) e^{-(2z/\delta)}$$

Where :
 P_{fw} = Forward Power
 P_{bw} = Backward Power
 a and b = Waveguide dimensions
 δ = Skin depth

Keithley configuration:

Rate = Medium; Filter =ON; RDGS=10; FILTER TYPE =MOVING AVERAGE; RANGE AUTO

After each calibration, a SAR measurement is performed on a validation dipole and compared with a NPL calibrated probe, to verify it.

	Bâtiment PONANT, Ave La Pérouse Zone du Technopole Brest Iroise, 29280 PLOUZANE. ☎ : +33 (0)2-98-05-13-34. 📠 : +33 (0)2-98-05-53-87.
---	---

PROBE UNCERTAINTIES

Calibration report of dosimetric SATIMO probe

Uncertainty on calibration system

ERROR SOURCES	Uncertainty value (%)	Probability Distribution	Divisor	ci	Standard Uncertainty (%)
Incident or forward power	3,00%	Rectangular	$\sqrt{3}$	1	1,732%
Reflected power	3,00%	Rectangular	$\sqrt{3}$	1	1,732%
Liquid conductivity	5,00%	Rectangular	$\sqrt{3}$	1	2,887%
Liquid permittivity	4,00%	Rectangular	$\sqrt{3}$	1	2,309%
Field homogeneity	3,00%	Rectangular	$\sqrt{3}$	1	1,732%
Field probe positioning	5,00%	Rectangular	$\sqrt{3}$	1	2,887%
Field probe linearity	3,00%	Rectangular	$\sqrt{3}$	1	1,732%
Combined standard uncertainty					4,761%
Expanded uncertainty (confidence interval of 95%)					9,331%

	Bâtiment PONANT, Ave La Pérouse Zone du Technopole Brest Iroise, 29280 PLOUZANE. ☎ : +33 (0)2-98-05-13-34. ☎ : +33 (0)2-98-05-53-87.
---	---

1. Calibration at 450.00 MHz

A. Calibration parameters.

Label	GSM450
Epsilon	43.33
Sigma	0.84 S/m
Temperature	21°C
Antenna gain	2.03 dB
Antenna S11	-10.50 dB
Low limit detection	1.66 V/m (2.31 mW/kg)

Calibration curves $e_i=f(V)$ ($i=1,2,3$) allow to obtain E-field value using the formula:
 $E=(e1*e1+e2*e2+e3*e3)^{pow(1/2)}$

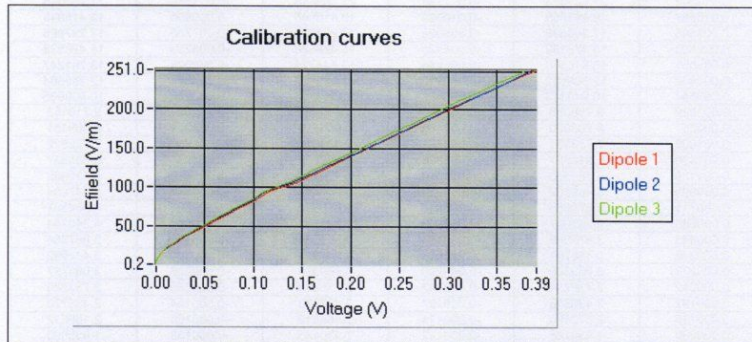

The following tables represent the calibration curves linearization by curve segment in CW signal.



Calibration coefficients for the three dipoles in CW:

v1	e1	v2	e2	v3	e3
0.390027	251.001230	-0.386042	250.695400	-0.376740	250.105988
0.366258	237.736292	-0.363554	236.787975	-0.354679	236.787975
0.339500	222.072445	-0.337008	221.186610	-0.328598	221.186610
0.311463	205.295068	-0.308712	204.712502	-0.300644	204.476157
0.283636	188.692124	-0.280417	187.939442	-0.273013	187.939442
0.256654	172.433067	-0.252967	171.745241	-0.245920	171.745241
0.230715	156.667434	-0.226695	156.042496	-0.220370	156.222813
0.206445	142.343234	-0.202087	141.775434	-0.196303	141.775434
0.183645	129.030238	-0.179221	128.367222	-0.173929	128.515544
0.162409	116.557803	-0.158001	116.092860	-0.153202	116.092860
0.142655	105.047888	-0.138513	104.628858	-0.134233	104.628858
0.114926	94.238168	-0.111965	93.862257	-0.110685	93.862257
0.104027	84.638434	-0.101130	84.300816	-0.099583	84.398340
0.092836	75.928948	-0.089992	75.626072	-0.087196	75.713499
0.080253	68.036895	-0.077392	67.765500	-0.074788	67.843957
0.068634	60.894908	-0.066076	60.652001	-0.063785	60.722110
0.058285	54.439678	-0.056065	54.222521	-0.054067	54.222521
0.049187	48.556435	-0.047203	48.362746	-0.045499	48.362746
0.041377	43.358902	-0.039629	43.235904	-0.038172	43.235904
0.034626	38.762659	-0.033080	38.608037	-0.031847	38.608037
0.028813	34.573630	-0.027466	34.435717	-0.026410	34.475417
0.023824	30.837228	-0.022664	30.714220	-0.021789	30.748598
0.019633	27.536241	-0.018631	27.426401	-0.017892	27.426401
0.016008	24.503942	-0.015174	24.406197	-0.014559	24.406197
0.013042	21.855528	-0.012358	21.768348	-0.011849	21.768348
0.010587	19.493705	-0.010024	19.415946	-0.009606	19.415946
0.008546	17.346896	-0.008093	17.297985	-0.007756	17.297985
0.006893	15.472199	-0.006525	15.428528	-0.006253	15.428528
0.005551	13.816360	-0.005245	13.744774	-0.005028	13.761247
0.004448	12.308602	-0.004220	12.259504	-0.004044	12.259504
0.003547	10.940343	-0.003371	10.909905	-0.003230	10.909905
0.002829	9.758078	-0.002696	9.719153	-0.002584	9.719153
0.002257	8.703900	-0.002159	8.658517	-0.002071	8.669181
0.001800	7.753551	-0.001731	7.731915	-0.001662	7.722622
0.001430	6.916527	-0.001386	6.888937	-0.001330	6.888937
0.001139	6.161560	-0.001110	6.130303	-0.001070	6.136982
0.000899	5.469502	-0.000886	5.447684	-0.000850	5.447684
0.000711	4.879656	-0.000707	4.870699	-0.000681	4.864397
0.000560	4.352907	-0.000568	4.335543	-0.000548	4.340254
0.000443	3.877568	-0.000464	3.867384	-0.000441	3.867384
0.000345	3.456781	-0.000369	3.442992	-0.000360	3.442992
0.000273	3.069309	-0.000298	3.060398	-0.000288	3.063727
0.000212	2.736734	-0.000242	2.725818	-0.000235	2.733280
0.000157	2.439318	-0.000197	2.433773	-0.000194	2.433773
0.000125	2.172484	-0.000171	2.168512	-0.000160	2.168512
0.000089	1.938165	-0.000142	1.930433	-0.000133	1.935690
0.000074	1.725784	-0.000111	1.718900	-0.000112	1.724797
0.000054	1.537689	-0.000095	1.524916	-0.000094	1.524916
0.000039	1.368867	-0.000080	1.363407	-0.000081	1.363407
0.000025	1.218869	-0.000069	1.214007	-0.000072	1.214007
0.000014	1.086023	-0.000067	1.081691	-0.000062	1.081691
0.000005	0.966789	-0.000055	0.962933	-0.000053	0.962933

	<p>Bâtiment PONANT, Ave La Pérouse Zone du Technopole Brest Iroise, 29280 PLOUZANE. ☎ : +33 (0)2-98-05-13-34. ☎ : +33 (0)2-98-05-53-87.</p>
---	---

B. Isotropy.

- Axial isotropy: 0.04 dB
- Hemispherical isotropy: 0.08 dB

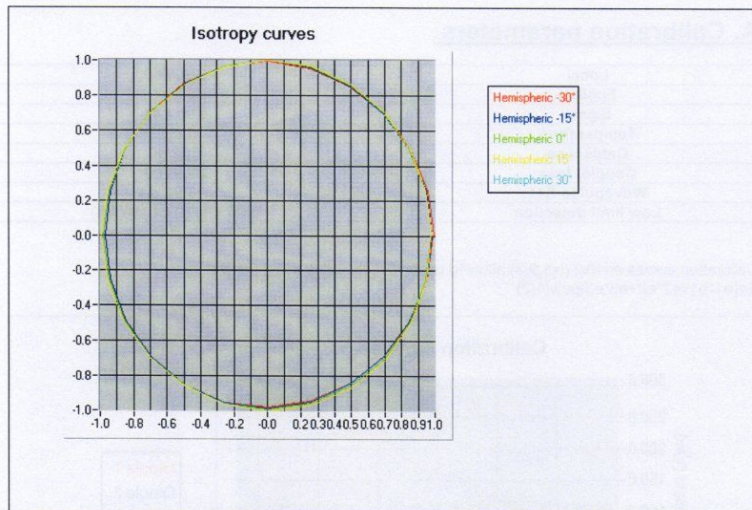

$E\text{-field } E \text{ (V/m)} = f(\phi, \theta)$

	Bâtiment PONANT, Ave La Pérouse Zone du Technopole Brest Iroise, 29280 PLOUZANE. ☎ : +33 (0)2-98-05-13-34. 📠 : +33 (0)2-98-05-53-87.
---	---

2. Calibration at 835.00 MHz

A. Calibration parameters.

Label	GSM850
Epsilon	43.72
Sigma	0.90 S/m
Temperature	21°C
Cable loss	0.00 dB
Coupler loss	20.50 dB
Waveguide S11	-13.91 dB
Low limit detection	0.96 V/m (0.84 mW/kg)

Calibration curves $e_i=f(V)$ ($i=1,2,3$) allow to obtain E-field value using the formula:
 $E=(e1*e1+e2*e2+e3*e3)pow(1/2)$

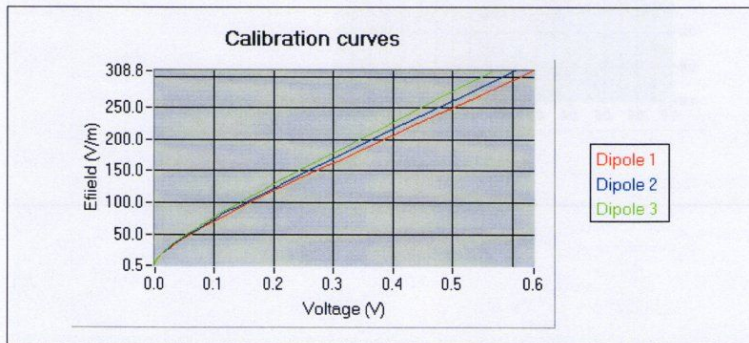

The following tables represent the calibration curves linearization by curve segment in CW signal.



SATIMO
The microwave vision company

Bâtiment PONANT, Ave La Pérouse
Zone du Technopole Brest Iroise, 29280 PLOUZANE.
☎ : +33 (0)2-98-05-13-34.
✉ : +33 (0)2-98-05-53-87.

Calibration coefficients for the three dipoles in CW:

v1	e1	v2	e2	v3	e3
0.635587	308.082146	-0.604183	308.789236	-0.565402	306.584464
0.529656	262.201294	-0.503486	262.612528	-0.471169	261.045773
0.441380	223.967252	-0.419571	224.131937	-0.392640	223.096863
0.306514	165.119244	-0.291369	164.929254	-0.272667	164.739481
0.290555	159.146719	-0.276427	158.963600	-0.258259	158.597995
0.268411	149.209919	-0.255467	149.038233	-0.238392	148.695455
0.244835	138.610998	-0.233209	138.451509	-0.217240	138.133080
0.220829	127.731407	-0.210592	127.584435	-0.195765	127.144533
0.196961	116.626621	-0.187954	116.492427	-0.174452	116.090770
0.173928	105.876040	-0.166016	105.632534	-0.153977	105.389594
0.151847	95.235242	-0.145092	95.125662	-0.134330	94.797676
0.130863	85.074164	-0.116894	84.976276	-0.113424	84.683284
0.110829	75.213828	-0.103844	75.127284	-0.097728	74.782106
0.086907	62.776585	-0.083093	62.704353	-0.076637	62.560137
0.074182	56.207943	-0.070921	56.078668	-0.065266	56.014143
0.063386	50.442627	-0.060565	50.384586	-0.055632	50.268705
0.054223	45.373021	-0.051774	45.373021	-0.047474	45.268666
0.046364	40.954129	-0.044245	40.954129	-0.040448	40.859937
0.039475	36.965594	-0.037645	36.923061	-0.034382	36.838139
0.033397	33.288765	-0.031834	33.250463	-0.028981	33.173988
0.027920	29.839922	-0.026578	29.839922	-0.024144	29.737036
0.022982	26.594859	-0.021858	26.594859	-0.019775	26.503163
0.018501	23.458362	-0.017588	23.431370	-0.015876	23.350580
0.013825	19.874568	-0.013101	19.851699	-0.011833	19.806042
0.011273	17.774512	-0.010688	17.754059	-0.009633	17.713227
0.009222	15.951359	-0.008761	15.933005	-0.007862	15.896361
0.007562	14.348209	-0.007180	14.331699	-0.006464	14.315209
0.006215	12.950833	-0.005899	12.935931	-0.005323	12.906178
0.005101	11.676097	-0.004850	11.662663	-0.004328	11.636839
0.004155	10.502620	-0.003953	10.490535	-0.003545	10.478466
0.003354	9.414510	-0.003197	9.403675	-0.002891	9.382049
0.002660	8.371392	-0.002539	8.371392	-0.002271	8.352139
0.002061	7.375607	-0.001985	7.367119	-0.001806	7.350176
0.001439	6.127703	-0.001390	6.120652	-0.001217	6.113610
0.001137	5.480216	-0.001117	5.473911	-0.001022	5.467612
0.000918	4.923769	-0.000902	4.918103	-0.000835	4.912446
0.000734	4.428918	-0.000732	4.428918	-0.000651	4.418732
0.000591	3.997585	-0.000601	3.992985	-0.000565	3.988391
0.000475	3.599959	-0.000499	3.595818	-0.000424	3.591681
0.000389	3.238156	-0.000421	3.234430	-0.000388	3.230709
0.000295	2.892662	-0.000318	2.889334	-0.000319	2.886009
0.000226	2.566242	-0.000286	2.566242	-0.000249	2.560339
0.000167	2.250597	-0.000204	2.248006	-0.000215	2.242836
0.000115	1.946694	-0.000163	1.944454	-0.000132	1.942217
0.000096	1.743001	-0.000139	1.740997	-0.000129	1.738992
0.000068	1.567825	-0.000121	1.564218	-0.000115	1.562420
0.000044	1.410256	-0.000114	1.407012	-0.000087	1.407012
0.000036	1.268522	-0.000088	1.271445	-0.000066	1.269982
0.000023	1.142346	-0.000071	0.959949	-0.000045	1.132954
0.000005	0.501457	-0.000054	0.597334	-0.000024	0.561644

	Bâtiment PONANT, Ave La Pérouse Zone du Technopole Brest Iroise, 29280 PLOUZANE. ☎ : +33 (0)2-98-05-13-34. 📠 : +33 (0)2-98-05-53-87.
---	---

B. Isotropy.

- Axial isotropy: 0.03 dB
 - Hemispherical isotropy: 0.04 dB

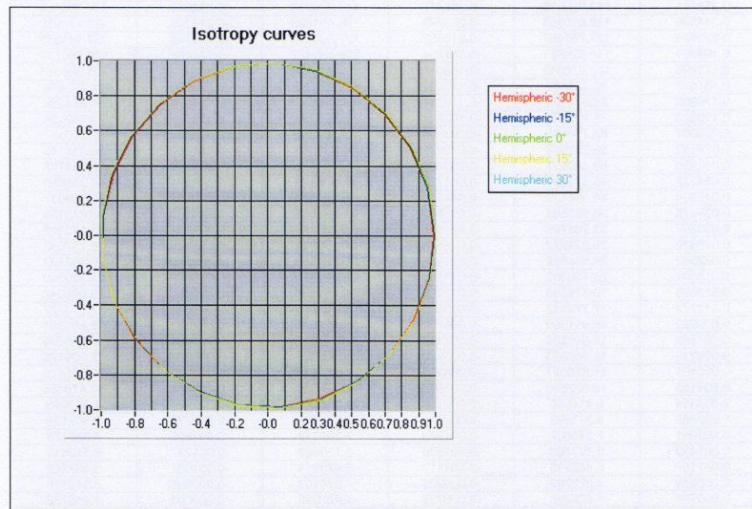

E-field E (V/m) = f(phi, theta)

C. Linearity.

- Linearity: 0.19 dB

	Bâtiment PONANT, Ave La Pérouse Zone du Technopole Brest Iroise, 29280 PLOUZANE. ☎ : +33 (0)2-98-05-13-34. 📠 : +33 (0)2-98-05-53-87.
---	---

3. Calibration at 900.00 MHz

A. Calibration parameters.

Label	GSM900
Epsilon	43.04
Sigma	0.98 S/m
Temperature	21°C
Cable loss	0.00 dB
Coupler loss	20.30 dB
Waveguide S11	-13.94 dB
Low limit detection	1.26 V/m (1.57 mW/kg)

Calibration curves $e_i=f(V)$ ($i=1,2,3$) allow to obtain E-field value using the formula:
 $E=(e1*e1+e2*e2+e3*e3)^{pow(1/2)}$

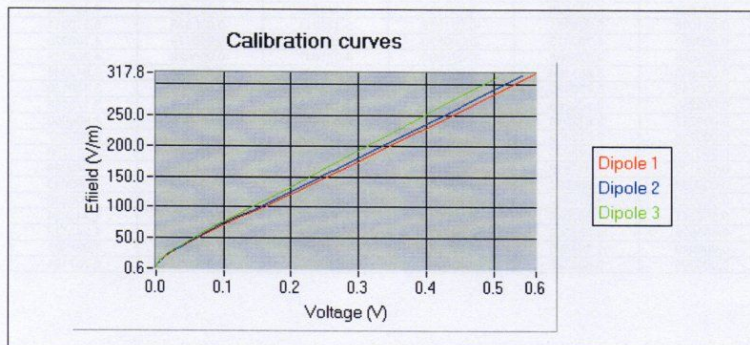

The following tables represent the calibration curves linearization by curve segment in CW signal.



Calibration coefficients for the three dipoles in CW:

v1	e1	v2	e2	v3	e3
0.562646	317.801076	-0.542112	313.053898	-0.505287	311.994322
0.468872	266.592145	-0.451760	263.347651	-0.421072	262.612228
0.390727	223.918036	-0.376466	221.925779	-0.350893	221.460484
0.271338	158.889567	-0.261435	158.706743	-0.243676	158.706743
0.253080	148.626202	-0.243021	148.455189	-0.226314	148.284371
0.232479	137.276242	-0.222726	137.276242	-0.207208	137.118287
0.210674	125.775305	-0.201577	125.775305	-0.187307	125.630584
0.188759	114.708442	-0.180478	114.576454	-0.167510	114.312937
0.167251	103.895176	-0.159872	103.775631	-0.148239	103.656224
0.146965	93.776794	-0.140482	93.668892	-0.130117	93.561113
0.127724	84.157995	-0.122159	84.061160	-0.112968	83.867826
0.108227	74.919588	-0.103052	74.833383	-0.096736	74.747278
0.092300	66.007819	-0.088290	65.931868	-0.081313	65.856004
0.071260	54.650655	-0.068090	54.524963	-0.062542	54.462225
0.060603	48.875969	-0.057889	48.819730	-0.053034	48.763558
0.051606	43.862701	-0.049262	43.812232	-0.045010	43.761820
0.043938	39.499843	-0.041926	39.454395	-0.038211	39.363651
0.037401	35.652943	-0.035651	35.611920	-0.032430	35.570943
0.031672	32.143664	-0.030156	32.106679	-0.027355	32.069736
0.026638	28.946455	-0.025333	28.913148	-0.022968	28.846650
0.022129	25.977381	-0.021035	25.917636	-0.018986	25.887814
0.018094	23.125727	-0.017164	23.099118	-0.015492	23.045990
0.014437	20.351450	-0.013691	20.328034	-0.012319	20.304644
0.010878	17.381826	-0.010300	17.341849	-0.009246	17.321893
0.008843	15.545166	-0.008371	15.509414	-0.007494	15.491568
0.007210	13.950680	-0.006832	13.934629	-0.006114	13.918594
0.005895	12.548603	-0.005586	12.534165	-0.005027	12.519742
0.004835	11.326491	-0.004587	11.313458	-0.004105	11.300440
0.003944	10.211637	-0.003749	10.199887	-0.003367	10.188151
0.003220	9.185343	-0.003068	9.174773	-0.002727	9.164218
0.002589	8.233707	-0.002482	8.224232	-0.002211	8.214769
0.002056	7.329855	-0.001974	7.321421	-0.001765	7.312996
0.001594	6.450529	-0.001556	6.443107	-0.001388	6.435694
0.001078	5.322251	-0.001056	5.310011	-0.000938	5.310011
0.000857	4.759873	-0.000870	4.754396	-0.000778	4.748925
0.000686	4.276568	-0.000690	4.271647	-0.000629	4.266732
0.000560	3.851194	-0.000566	3.846763	-0.000528	3.842336
0.000445	3.476125	-0.000481	3.472125	-0.000405	3.468130
0.000355	3.130368	-0.000377	3.126766	-0.000348	3.123168
0.000277	2.812518	-0.000324	2.809282	-0.000306	2.806050
0.000214	2.512439	-0.000245	2.512439	-0.000253	2.509547
0.000165	2.228925	-0.000202	2.226360	-0.000169	2.223798
0.000122	1.952519	-0.000183	1.950273	-0.000168	1.948029
0.000084	1.686924	-0.000118	1.684983	-0.000133	1.683043
0.000059	1.510412	-0.000089	1.508674	-0.000098	1.506938
0.000041	1.357048	-0.000045	1.353478	-0.000063	1.443934
0.000025	1.222068	-0.000023	1.240128	-0.000028	1.240128
0.000019	1.104320	-0.000015	1.021952	-0.000017	1.084302
0.000008	0.605325	-0.000006	0.803439	-0.000007	0.757194

	<p>Bâtiment PONANT, Ave La Pérouse Zone du Technopole Brest Iroise, 29280 PLOUZANE. ☎ : +33 (0)2-98-05-13-34. 📠 : +33 (0)2-98-05-53-87.</p>
---	--

B. Isotropy.

- Axial isotropy: 0.05 dB
- Hemispherical isotropy: 0.06 dB

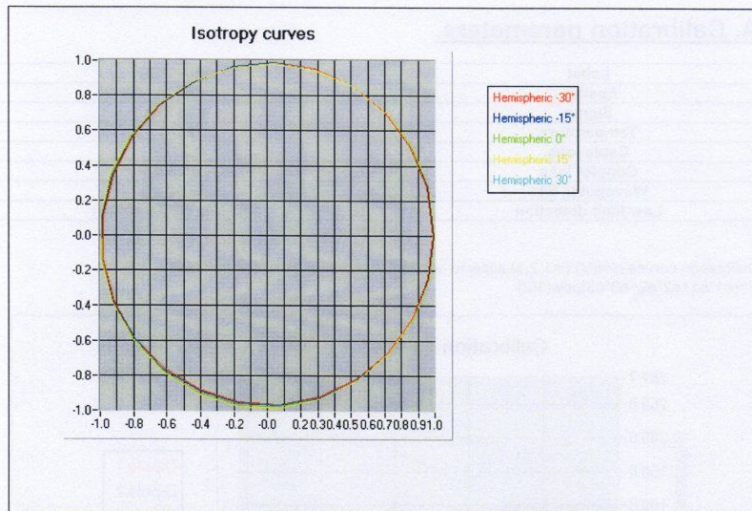

$E\text{-field } E \text{ (V/m)} = f(\phi, \theta)$

C. Linearity.

- Linearity: 0.18 dB

	Bâtiment PONANT, Ave La Pérouse Zone du Technopole Brest Iroise, 29280 PLOUZANE. ☎ : +33 (0)2-98-05-13-34. 📠 : +33 (0)2-98-05-53-87.
---	---

4. Calibration at 1747.00 MHz

A. Calibration parameters.

Label	GSM1800
Epsilon	39.10
Sigma	1.36 S/m
Temperature	21°C
Cable loss	0.00 dB
Coupler loss	20.18 dB
Waveguide S11	-13.10 dB
Low limit detection	1.05 V/m (1.50 mW/kg)

Calibration curves $e_i=f(V)$ ($i=1,2,3$) allow to obtain E-field value using the formula:
 $E=(e_1 \cdot e_1 + e_2 \cdot e_2 + e_3 \cdot e_3) \text{pow}(1/2)$

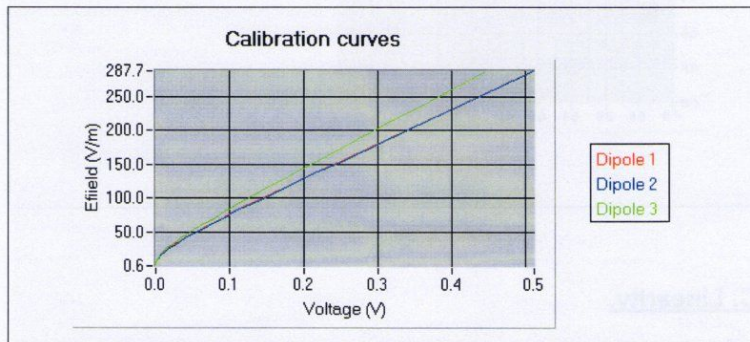

The following tables represent the calibration curves linearization by curve segment in CW signal.

Bâtiment PONANT, Ave La Pérouse
 Zone du Technopole Brest Iroise, 29280 PLOUZANE.
 ☎ : +33 (0)2-98-05-13-34.
 📠 : +33 (0)2-98-05-53-87.

Calibration coefficients for the three dipoles in CW:

v1	e1	v2	e2	v3	e3
0.510721	286.851496	-0.510995	287.693425	-0.443939	286.309825
0.425601	243.350716	-0.425829	243.900692	-0.369949	243.053215
0.354668	207.100067	-0.354858	207.406747	-0.308291	207.006040
0.246297	151.644785	-0.246429	151.644785	-0.214091	151.819474
0.219264	137.983603	-0.219592	137.824835	-0.190283	138.142555
0.192454	124.258893	-0.193001	124.258893	-0.166831	124.402035
0.167259	111.257035	-0.167958	111.257035	-0.144922	111.385198
0.144913	99.615629	-0.145778	99.615629	-0.125520	99.732447
0.125258	89.295070	-0.126254	89.295070	-0.107824	89.397934
0.106977	80.135967	-0.106266	80.135967	-0.093715	80.228280
0.093604	72.082109	-0.094642	71.999169	-0.080896	72.165144
0.080853	64.912373	-0.081878	64.912373	-0.069798	64.987148
0.069882	58.590537	-0.070823	58.590537	-0.060179	58.725602
0.059202	52.339248	-0.060092	52.339248	-0.050784	52.399541
0.048472	45.795993	-0.049268	45.795993	-0.041401	45.848748
0.039793	40.302082	-0.040486	40.302082	-0.033855	40.348509
0.032772	35.672003	-0.033401	35.713095	-0.027786	35.754234
0.027117	31.792705	-0.027629	31.792705	-0.022876	31.829328
0.022403	28.400598	-0.022872	28.400598	-0.018844	28.433314
0.018563	25.458188	-0.018968	25.458188	-0.015557	25.516875
0.015394	22.873229	-0.015716	22.873229	-0.012846	22.925957
0.012741	20.621844	-0.013045	20.621844	-0.010627	20.645598
0.010592	18.613477	-0.010825	18.613477	-0.008803	18.634918
0.008587	16.646675	-0.008809	16.646675	-0.007132	16.665850
0.006690	14.565570	-0.006860	14.565570	-0.005540	14.582317
0.005237	12.818214	-0.005410	12.818214	-0.004342	12.832979
0.004144	11.345601	-0.004259	11.345601	-0.003442	11.358670
0.003298	10.100142	-0.003432	10.100142	-0.002748	10.111777
0.002640	9.022513	-0.002740	9.022513	-0.002205	9.032906
0.002126	8.087745	-0.002209	8.087745	-0.001783	8.097063
0.001712	7.258176	-0.001791	7.258176	-0.001445	7.274820
0.001391	6.543762	-0.001478	6.536232	-0.001178	6.551300
0.001132	5.906462	-0.001223	5.899667	-0.000970	5.913267
0.000859	5.156173	-0.000921	5.150241	-0.000749	5.162112
0.000667	4.511568	-0.000735	4.511568	-0.000578	4.516765
0.000509	3.974912	-0.000572	3.974912	-0.000456	3.979490
0.000390	3.522309	-0.000463	3.522309	-0.000366	3.526366
0.000322	3.135649	-0.000360	3.135649	-0.000285	3.139262
0.000211	2.801093	-0.000286	2.801093	-0.000240	2.807550
0.000192	2.510888	-0.000251	2.510888	-0.000198	2.513781
0.000159	2.255939	-0.000205	2.255939	-0.000171	2.260171
0.000123	2.031550	-0.000158	2.031550	-0.000140	2.036558
0.000101	1.835809	-0.000132	1.833696	-0.000119	1.840042
0.000035	1.450434	-0.000124	1.628649	-0.000098	1.630525
0.000022	1.075120	-0.000095	1.426683	-0.000078	1.429972
0.000006	0.613424	-0.000079	1.258425	-0.000072	1.258217
		-0.000066	1.116420	-0.000064	1.117705
		-0.000060	0.993866	-0.000053	0.993182
		-0.000056	0.888848	-0.000042	0.862972
		-0.000046	0.794928	-0.000031	0.718691
		-0.000036	0.622424	-0.000020	0.580812

	<p>Bâtiment PONANT, Ave La Pérouse Zone du Technopole Brest Iroise, 29280 PLOUZANE. ☎ : +33 (0)2-98-05-13-34. 📠 : +33 (0)2-98-05-53-87.</p>
---	--

B. Isotropy.

- Axial isotropy: 0.06 dB
- Hemispherical isotropy: 0.06 dB

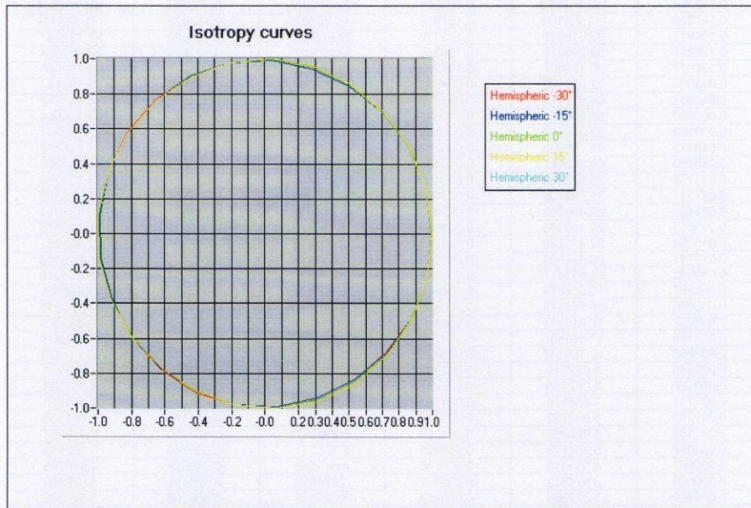

E-field E (V/m) = $f(\phi, \theta)$

C. Linearity.

- Linearity: 0.19 dB

	Bâtiment PONANT, Ave La Pérouse Zone du Technopole Brest Iroise, 29280 PLOUZANE. ☎ : +33 (0)2-98-05-13-34. 📠 : +33 (0)2-98-05-53-87.
---	---

5. Calibration at 1950.00 MHz

A. Calibration parameters.

Label	IMT2000
Epsilon	39.43
Sigma	1.40 S/m
Temperature	21°C
Cable loss	0.00 dB
Coupler loss	20.07 dB
Waveguide S11	-36.66 dB
Low limit detection	1.27 V/m (2.30 mW/kg)

Calibration curves $e_i=f(V)$ ($i=1,2,3$) allow to obtain E-field value using the formula:
 $E=(e1*e1+e2*e2+e3*e3)^{pow(1/2)}$

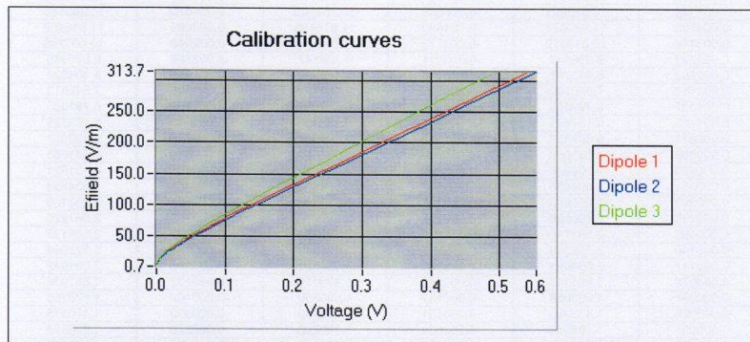

The following tables represent the calibration curves linearization by curve segment in CW signal.

Bâtiment PONANT, Ave La Pérouse
 Zone du Technopole Brest Iroise, 29280 PLOUZANE.
 ☎ : +33 (0)2-98-05-13-34.
 📠 : +33 (0)2-98-05-53-87.

Calibration coefficients for the three dipoles in CW:

v1	e1	v2	e2	v3	e3
0.538560	311.624390	-0.553261	313.722699	-0.486674	310.530862
0.448800	264.027659	-0.461051	265.427130	-0.405562	263.294326
0.374000	224.363717	-0.384209	225.180822	-0.337968	223.930545
0.259722	163.676878	-0.266812	163.676878	-0.234700	163.676878
0.228065	147.057552	-0.234742	146.888343	-0.205692	147.057552
0.198097	131.216163	-0.204667	131.216163	-0.178433	131.065182
0.171141	116.677559	-0.177391	116.811965	-0.153946	116.677559
0.147777	104.108774	-0.153669	104.108774	-0.132662	103.989984
0.127488	92.893929	-0.132975	93.000939	-0.114181	92.893929
0.108273	83.269764	-0.115177	83.269764	-0.098330	83.173952
0.095107	74.642699	-0.099090	74.642699	-0.084669	74.642699
0.082157	67.140927	-0.086401	67.218270	-0.072924	67.140927
0.070984	60.602052	-0.074821	60.602052	-0.062842	60.532323
0.060312	54.136146	-0.063747	54.136146	-0.053232	54.136146
0.049369	47.368249	-0.052337	47.368249	-0.043407	47.313746
0.040527	41.685722	-0.043073	41.685722	-0.035485	41.637757
0.033371	36.896683	-0.035550	36.854230	-0.029113	36.854230
0.027567	32.808573	-0.029424	32.808573	-0.023965	32.808573
0.022785	29.308078	-0.024373	29.308078	-0.019748	29.274355
0.018872	26.271649	-0.020203	26.271649	-0.016302	26.241420
0.015625	23.576934	-0.016768	23.576934	-0.013460	23.549805
0.012951	21.231825	-0.013913	21.231825	-0.011131	21.231825
0.010739	19.164052	-0.011576	19.164052	-0.009212	19.164052
0.008971	17.397519	-0.009676	17.397519	-0.007705	17.397519
0.006970	15.222547	-0.007534	15.205032	-0.005982	15.205032
0.005454	13.380961	-0.005908	13.365565	-0.004673	13.365565
0.004298	11.830071	-0.004690	11.816458	-0.003690	11.816458
0.003418	10.519312	-0.003733	10.519312	-0.002948	10.507209
0.002733	9.386147	-0.003014	9.386147	-0.002366	9.375348
0.002203	8.413707	-0.002423	8.413707	-0.001915	8.404026
0.001783	7.550702	-0.001966	7.550702	-0.001546	7.542013
0.001437	6.799663	-0.001604	6.799663	-0.001262	6.791939
0.001163	6.137441	-0.001316	6.130380	-0.001040	6.123325
0.000871	5.327057	-0.001003	5.327057	-0.000779	5.320927
0.000662	4.661088	-0.000780	4.661088	-0.000618	4.661088
0.000499	4.106646	-0.000609	4.106646	-0.000483	4.101921
0.000384	3.634858	-0.000487	3.634858	-0.000381	3.634858
0.000303	3.235843	-0.000391	3.235843	-0.000307	3.232120
0.000239	2.890596	-0.000316	2.887270	-0.000253	2.887270
0.000182	2.591119	-0.000265	2.588136	-0.000208	2.588136
0.000140	2.325345	-0.000217	2.325345	-0.000173	2.322669
0.000117	2.094051	-0.000191	2.094051	-0.000143	2.091642
0.000079	1.890112	-0.000150	1.890112	-0.000132	1.887936
0.000057	1.680689	-0.000137	1.680689	-0.000104	1.678755
0.000029	1.473966	-0.000101	1.472269	-0.000090	1.470575
0.000021	1.298636	-0.000084	1.298636	-0.000075	1.298636
0.000017	1.152093	-0.000080	1.152093	-0.000072	1.148120
0.000012	1.025622	-0.000069	1.025622	-0.000060	1.024442
0.000008	0.915140	-0.000064	0.914087	-0.000051	0.914087
0.000004	0.804656	-0.000051	0.818440	-0.000048	0.819383
		-0.000049	0.735338	-0.000045	0.734492
				-0.000036	0.659154

	<p>Bâtiment PONANT, Ave La Pérouse Zone du Technopole Brest Iroise, 29280 PLOUZANE. ☎ : +33 (0)2-98-05-13-34. 📠 : +33 (0)2-98-05-53-87.</p>
---	--

B. Isotropy.

- Axial isotropy: 0.07 dB
- Hemispherical isotropy: 0.07 dB

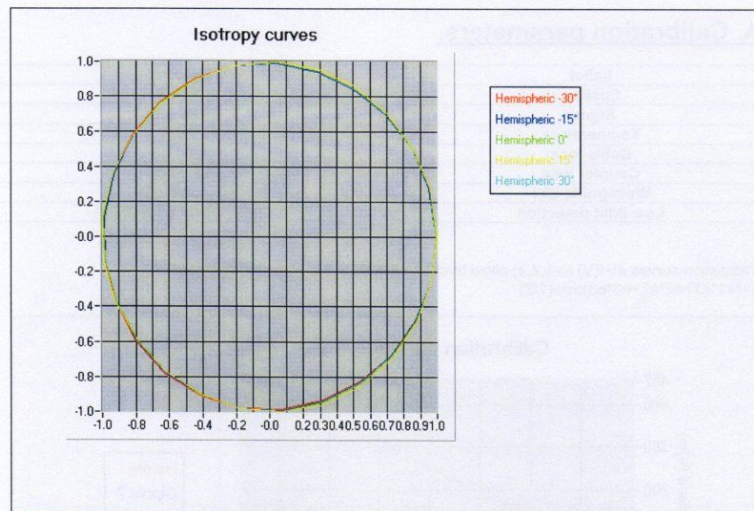

$E\text{-field } E \text{ (V/m)} = f(\phi, \theta)$

C. Linearity.

- Linearity: 0.17 dB

	Bâtiment PONANT, Ave La Pérouse Zone du Technopole Brest Iroise, 29280 PLOUZANE. ☎ : +33 (0)2-98-05-13-34. 📠 : +33 (0)2-98-05-53-87.
---	---

6. Calibration at 2450.00 MHz

A. Calibration parameters.

Label	Bluetooth
Epsilon	37.79
Sigma	1.85 S/m
Temperature	21°C
Cable loss	0.00 dB
Coupler loss	21.50 dB
Waveguide S11	-15.00 dB
Low limit detection	0.92 V/m (1.51 mW/kg)

Calibration curves $e_i=f(V)$ ($i=1,2,3$) allow to obtain E-field value using the formula:
 $E=(e1*e1+e2*e2+e3*e3)^{pow(1/2)}$

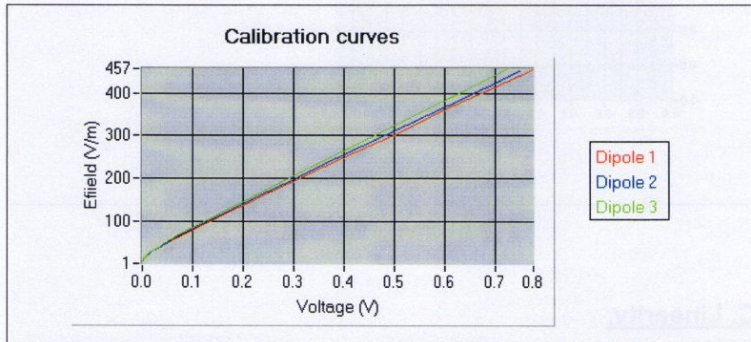

The following tables represent the calibration curves linearization by curve segment in CW signal.

Bâtiment PONANT, Ave La Pérouse
 Zone du Technopole Brest Iroise, 29280 PLOUZANE.
 ☎ : +33 (0)2-98-05-13-34.
 📠 : +33 (0)2-98-05-53-87.

Calibration coefficients for the three dipoles in CW:

v1	e1	v2	e2	v3	e3
0.775885	454.454927	-0.748460	450.440543	-0.725597	456.774143
0.620606	368.804659	-0.606912	370.466546	-0.580020	370.842348
0.499623	301.991331	-0.482063	299.834178	-0.465640	303.231159
0.396761	245.082582	-0.386170	245.475034	-0.374743	249.392407
0.319389	202.162943	-0.311188	202.849779	-0.297735	203.642804
0.257308	167.598066	-0.249926	167.884910	-0.239781	169.064921
0.207152	139.527842	-0.198963	138.629007	-0.192512	140.694550
0.168348	117.658041	-0.158939	115.463102	-0.155199	118.116132
0.135618	99.035731	-0.127146	96.856391	-0.123856	98.937582
0.108916	83.645541	-0.101857	81.836550	-0.098522	83.195036
0.086939	70.755962	-0.082444	70.088170	-0.078125	70.899915
0.070561	60.938992	-0.066997	60.524608	-0.063011	60.424288
0.044971	44.928910	-0.042854	44.877214	-0.040169	44.825576
0.039748	41.497877	-0.037893	41.497877	-0.035485	41.450130
0.032394	36.477569	-0.030815	36.477569	-0.028813	36.435596
0.026448	32.212608	-0.025118	32.212608	-0.023444	32.175543
0.021679	28.643487	-0.020566	28.643487	-0.019158	28.610529
0.017778	25.557942	-0.016851	25.557942	-0.015687	25.499160
0.014629	22.883681	-0.013855	22.857350	-0.012869	22.831050
0.012058	20.536475	-0.011390	20.536475	-0.010563	20.512844
0.009929	18.472509	-0.009400	18.472509	-0.008694	18.451255
0.008208	16.673465	-0.007749	16.654282	-0.007181	16.635118
0.006421	14.605819	-0.006052	14.605819	-0.005596	14.589013
0.005301	13.213743	-0.005014	13.213743	-0.004624	13.198540
0.004097	11.601814	-0.003904	11.601814	-0.003606	11.588464
0.003229	10.245328	-0.003075	10.245328	-0.002831	10.233540
0.002561	9.099674	-0.002432	9.099674	-0.002253	9.089205
0.002029	8.110095	-0.001946	8.110095	-0.001810	8.100763
0.001647	7.253138	-0.001577	7.253138	-0.001453	7.244792
0.001305	6.509174	-0.001289	6.509174	-0.001171	6.485386
0.001041	5.854985	-0.001043	5.848249	-0.000945	5.810292
0.000861	5.273301	-0.000842	5.278687	-0.000787	5.287375
0.000672	4.678586	-0.000677	4.645430	-0.000618	4.663597
0.000540	4.213738	-0.000541	4.197841	-0.000510	4.216921
0.000396	3.639535	-0.000442	3.724311	-0.000399	3.702094
0.000295	3.175437	-0.000334	3.208253	-0.000309	3.224887
0.000257	2.982186	-0.000267	2.841382	-0.000262	2.945105
0.000166	2.458408	-0.000224	2.578572	-0.000197	2.507241
0.000151	2.360940	-0.000169	2.197068	-0.000172	2.316902
0.000104	2.025398	-0.000158	2.112516	-0.000141	2.056560
0.000072	1.760726	-0.000131	1.889000	-0.000122	1.879253
0.000062	1.669433	-0.000106	1.655346	-0.000105	1.705051
0.000037	1.415672	-0.000087	1.452851	-0.000076	1.357225
0.000032	1.359248	-0.000081	1.382758	-0.000059	1.103480
0.000032	1.359248	-0.000061	1.117810	-0.000051	0.955439
-0.000001	0.902308	-0.000050	0.940804	-0.000044	0.810758
-0.000008	0.767889	-0.000046	0.867531	-0.000039	0.698043
-0.000013	0.658095	-0.000041	0.766146	-0.000036	0.602865
-0.000017	0.561131	-0.000034	0.595901	-0.000033	0.516890
		-0.000031	0.513790		

	<p>Bâtiment PONANT, Ave La Pérouse Zone du Technopole Brest Iroise, 29280 PLOUZANE. ☎ : +33 (0)2-98-05-13-34. 📠 : +33 (0)2-98-05-53-87.</p>
---	--

B. Isotropy.

- Axial isotropy: 0.07 dB
 - Hemispherical isotropy: 0.06 dB

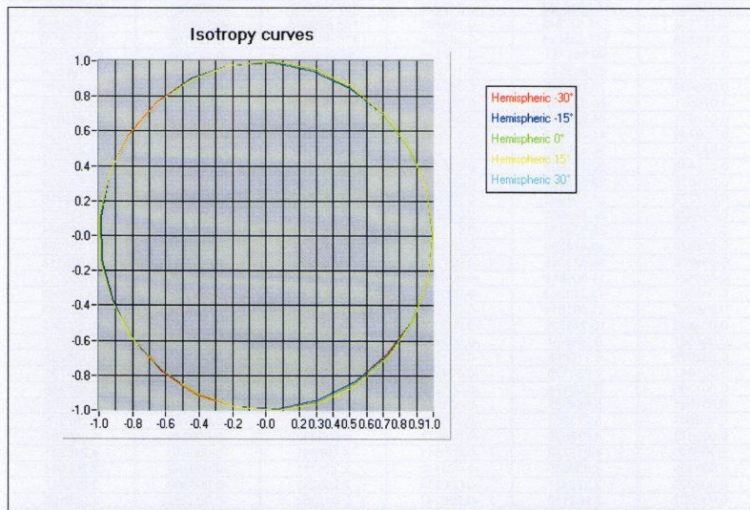

E-field E (V/m) = $f(\phi, \theta)$

C. Linearity.

- Linearity: 0.20 dB

11. Annex B: 11. dipoles reference SAR value and calibration



Verification of measuring instrument

Instrument checked : REFERENCE DIPOLE
 Manufacturer : ANTENNESSA / SANMO
 Model : 450 MHz
 Serial number : SN 39/05 DIPB26
 Date of inspection : 20/02/2014
 Measured quantity (unit) : RETURN LOSS (dB)

Measurements
 Return loss at the frequency of use : -28,32 dB

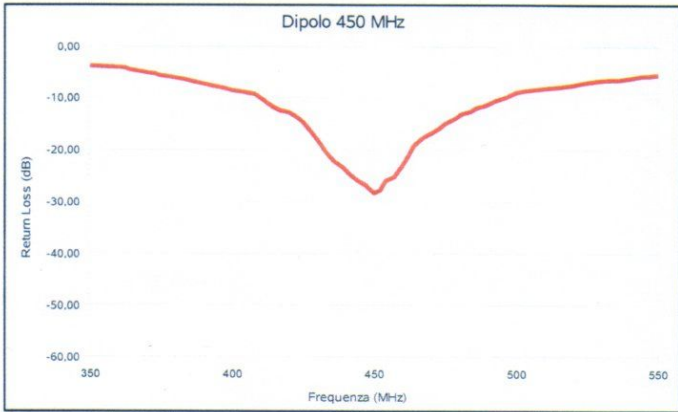

Instrumentation used for verification:

Instrument : VECTOR NETWORK ANALYZER
 Manufacturer : ANRITSU
 Model : MS 4622B
 Serial Number : 984502

On the basis of measurements carried out the instrument
 is is not
 appropriate for the use within the activities of SICOM.

Test Operator : *Antonio Sicari*

Pag. 1 of 1

Dipole historical data

Instrument checked : REFERENCE DIPOLE
Manufacturer : ALENNESSA / SATINO
Model : 450.MHz
Serial number : SN. 39/05 DIPB26
Date of inspection : 21/02/2014
Measured quantity (unit) : SAR

Date of measurement: 21/02/2014

A. Experimental conditions.

Phantom	Validation plane
Device Position	Dipole
Band	450 MHz
Channel	Middle
Signal	CW
Probe Path	Adaptative 1 max
Probe	EP_60

B. SAR Measurement Results:

Frequency (MHz)	450.0
Relative permittivity (real part)	56.74
Conductivity (S/m)	0.942

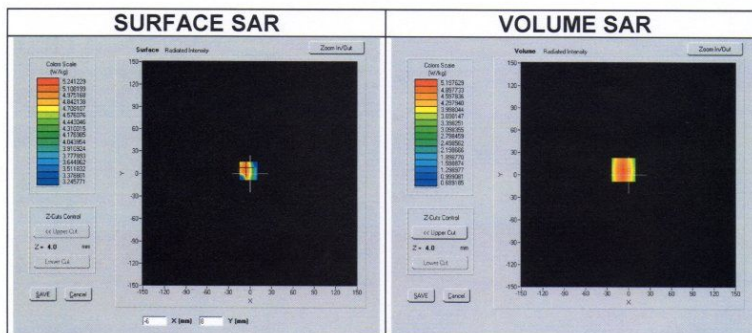

SAR	SAR (W/kg)	Reference value (W/kg)	Variation (%)	RESULT
SAR 1g	5.14	5.05	+1.78	PASS
SAR 10g	3.51	3.47	+1.15	PASS

	SAR (W/Kg)	SAR REFERENCE MANUFACTURER VALUE (W/Kg)	VARIATION (%)	VERDICT
SAR 10g	3,51	3,47	+ 1,15 %	PASS
SAR 1g	5,14	5,05	+ 1,78 %	PASS

On the basis of measurements carried out the instrument
is is not
appropriate for the use within the activities of SICOM.

Test Operator

