

Functional Description

MITSUMI Bluetooth Module

“ WML-C29###”

04/June/2004

Hardware: Version 1

Ultra-small and thin size achieved through use of high density mounting technology.

1. APPLICATIONS

Notebook PCs, mobile phones, digital cameras, PC peripherals, PDA.

2. DESCRIPTIONS

Wireless communication module conforming to Bluetooth Ver.1.2.

3. FEATURES

- 1) Ultra-small and thin size achieved through use of high density mounting technology.
- 2) SMD type can be surface mounted.
- 3) High sensitivity supports communications of up to 10 m.
- 4) UART and PCMF interfaces enable wide range of applications.
- 5) Conforms to FCC, CE and other countries' EMI standards.
- 6) Supports Bluetooth Class2.

Note) The BLUETOOTH trademarks are owned by Bluetooth SIG, INC.,U.S.A.

4. SPECIFICATIONS

Item	Specifications
Frequency	2402 to 2480 MHz
Modulation	FHSS / GFSK
Channel intervals	1 MHz
Number of channels	79 CH
Transmission rate	721 kbps
Receive sensitivity	-80 dBm typ.
Output level (Class2)	4 dBm max.

TM

©1998-2000 MITSUMI Electronics Corp. All rights reserved. MITSUMI is a trademark of MITSUMI Electronics Corporation.

Other company names and products names are trademarks of their respective companies.

Product specifications are subject to revisions or changes without notification.

5. TERMINAL DESCRIPTION

No.	Symbol	I/O	Description
1	GND		Ground
2	VDD1		Supply voltage 1.8 V
3	RST	I	Reset if high
4	AIO [1]	I/O	Programmable I/O line
5	SPI_MISO	O	Synchronous Serial Interface data output
6	SPI_CSB	I	Chip select for Synchronous Serial Interface
7	SPI_CLK	I	Synchronous Serial Interface Clock
8	SPI_MOSI	I	Synchronous Serial Interface data input
9	VDD2		Supply voltage 3.3V (Operating voltage for memory & AIO)
10	GND		Ground
11	UART_CTS	I	Asynchronous serial data CTS
12	UART_RTS	O	Asynchronous serial data RTS
13	UART_TX	O	Asynchronous serial data output
14	UART_RX	I	Asynchronous serial data input
15	PCM_CLK	I/O	Synchronous PCM data clock
16	PCM_IN	I	Synchronous PCM data input
17	PCM_SYNC	I/O	Synchronous data strobe
18	PCM_OUT	O	Synchronous PCM data out
19	VDD3		Supply voltage 3.3V (Operating voltage for PIO & all other Input / Output)
20	GND		Ground
21	AIO [0]	I/O	Programmable I/O line
22	PIO [9]	I/O	Programmable I/O line
23	PIO [2]	I/O	Programmable I/O line
24	PIO [5]	I/O	Programmable I/O line
25	PIO [6]	I/O	Programmable I/O line
26	PIO [3]	I/O	Programmable I/O line
27	PIO [8]	I/O	Programmable I/O line
28	PIO [4]	I/O	Programmable I/O line
29	PIO [7]	I/O	Programmable I/O line
30	GND		Ground
31	ANT	I/O	RF input/output
32	GND		Ground

6. BLOCK DIAGRAM

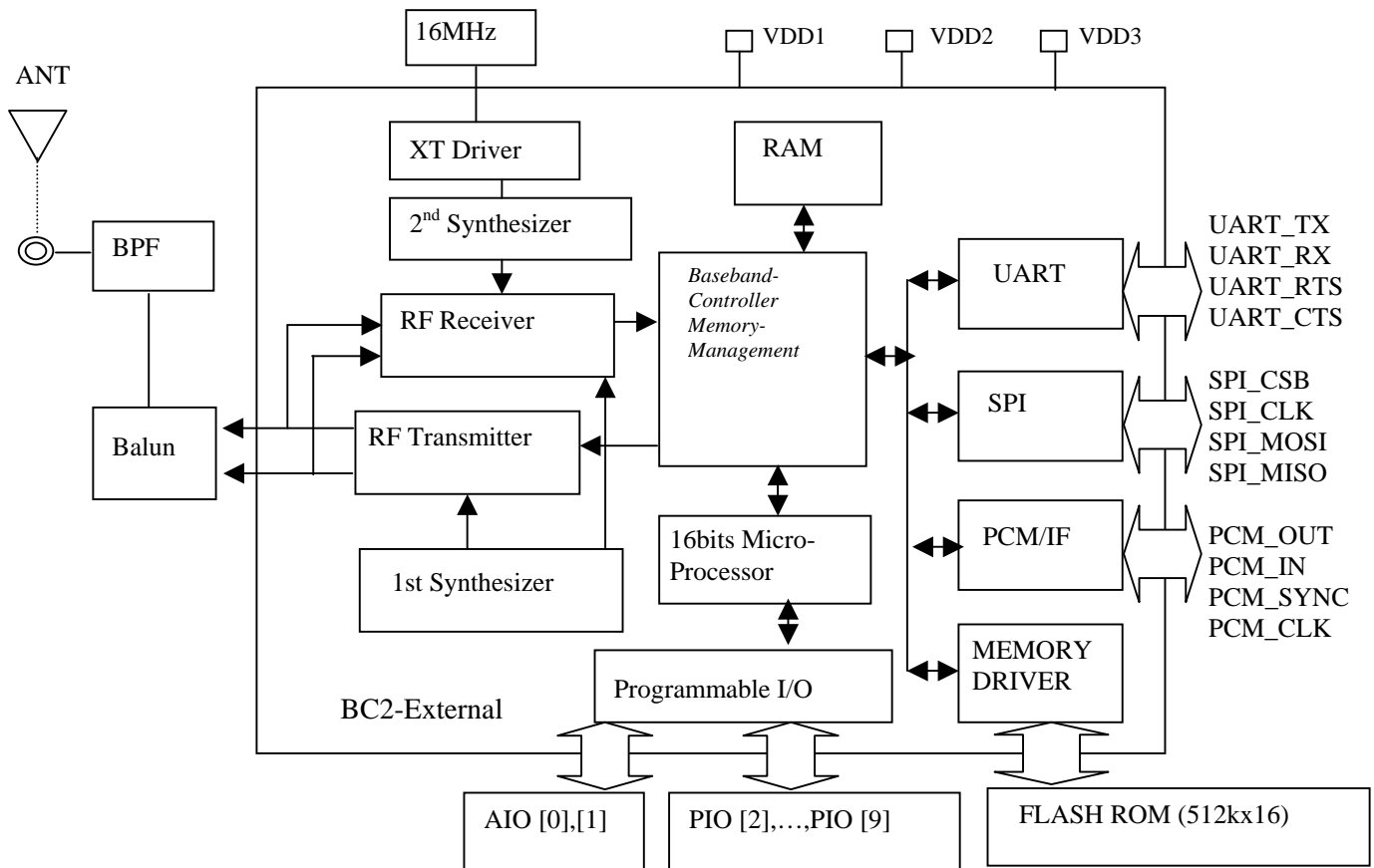

7. PCM IF

PCM_OUT, PCM_IN, PCM_CLK, PCM_SYNC carry one of bi-directional channel of voice data using 13bits PCM at 8ks/s.

PCM_SYNC operates at a fixed clock frequency of 8kHz.

PCM_CLK operates at a fixed clock frequency of 256kHz.

Bits 1 to 13 of the PCM_OUT data carry the current output sample value.
Bits 14 to 16 carry a three bit signal level value.

Reference PCM audio device is MC145483.

8. PIO PORT

The PIO port is general purpose IO interface and the ports consists of 8 programmable, Bi-directional PIO [2:9] . The maximum current drive capability is 4mA.

9. OVERALL APPEARANCE

