

Functional Description

22/Jun/2001

MITSUMI

Bluetooth Module “ WML-C05XX”

Ultra-small and thin size achieved through use of high density mounting technology.

1. APPLICATIONS

Notebook PCs, mobile phones, digital cameras, PC peripherals, PDA.

2. DESCRIPTIONS

Wireless communication module conforming to Bluetooth Ver.1.0B.

3. FEATURES

- 1) Ultra-small and thin size achieved through use of high density mounting technology.
 - 2) SMD type can be surface mounted.
 - 3) High sensitivity supports communications of up to 10 m.
 - 4) UART, USB and PCMIF interfaces enable wide range of applications.
 - 5) Conforms to FCC, CE and other countries' EMI standards.
 - 6) Supports Bluetooth Class2.
 - 7) In order to make stable performance, inside of module has voltage regulator.
- Note) The BLUETOOTH trademarks are owned by Telefonaktiebolaget L M, Ericsson, Sweden.

4. SPECIFICATIONS

Item	Specifications
Frequency	2402 to 2480 MHz
Modulation	FHSS / GFSK
Channel intervals	1 MHz
Number of channels	79 CH
Power supply voltage	3.0 V (typ.), 2.9 ~ 3.4V
Transmission rate	721 kbps
Receive sensitivity	-88 dBm typ.
Output level (Class2)	4 dBm max.

TM

©1998-2000 MITSUMI Electronics Corp. All rights reserved. MITSUMI is a trademark of MITSUMI Electronics Corporation.

Other company names and products names are trademarks of their respective companies.

Product specifications are subject to revisions or changes without notification.

5. TERMINAL DESCRIPTION

No.	Symbol	I/O	Description
1	PIO [0] / RXEN	O	Control output for external LNA (=PIO [0])
2	PIO [1] / TXEN	O	Control output for external PA (=PIO [1])
3	GND		Ground
4	GND		Ground
5	PIO [4] / IRQ1	I/O	Programmable I/O line/Interrupt request1
6	PIO [5] / IRQ2	I/O	Programmable I/O line/Interrupt request2
7	PIO [6]	I/O	Programmable I/O line
8	PIO [7]	I/O	Programmable I/O line
9	PCM_OUT	O	Synchronous PCM data out
10	PCM_CLK	I/O	Synchronous PCM data clock
11	PCM_IN	I	Synchronous PCM data input
12	PCM_SYNC	I/O	Synchronous data strobe
13	GND		Ground
14	VDD		Supply voltage 3.0
15	GND		Ground
16	SPI_CSB	I	Chip select for Synchronous Serial Interface
17	SPI_MOSI	I	Synchronous Serial Interface data input
18	SPI_CLK	I	Synchronous Serial Interface Clock
19	SPI_MISO	O	Synchronous Serial Interface data output
20	UART_CTS/USB_D-	I	Asynchronous serial data CTS/USB Data-
21	UART_RTS/USB_D+	O	Asynchronous serial data RTS/USB Data+
22	UART_RX	I	Asynchronous serial data input
23	UART_TX	O	Asynchronous serial data output
24	PIO [3]	I/O	Data line for EEPROM
25	PIO [2]	I	CLOCK for EEPROM
26	RST	I	Not Available
27	GND		Ground
28	ANT	I/O	RF input/output

6. BLOCK DIAGRAM

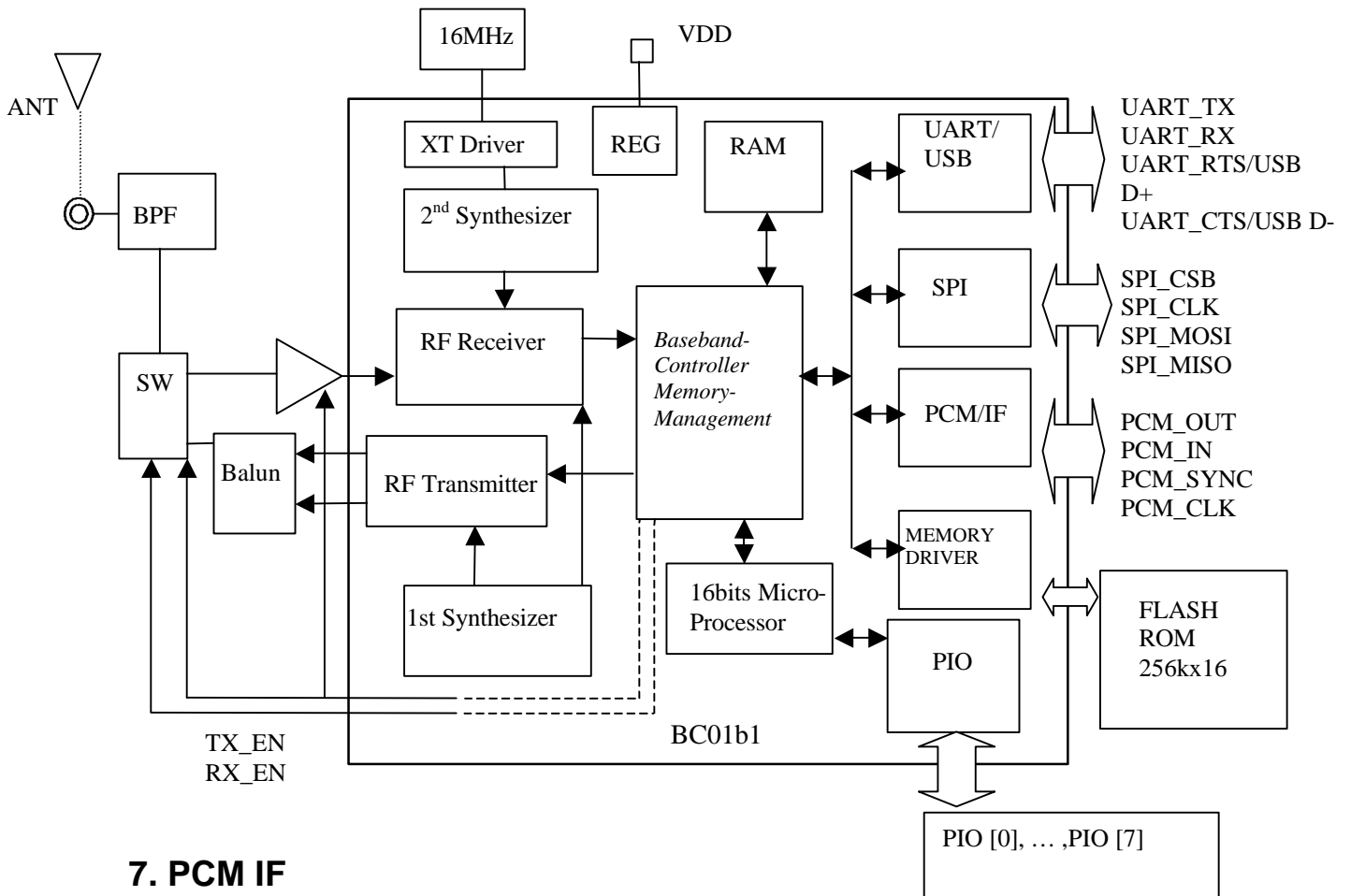

7. PCM IF

PCM_OUT, PCM_IN, PCM_CLK, PCM_SYNC carry one of bi-directional channel of voice data using 13bits PCM at 8ks/s.

PCM_SYNC operates at a fixed clock frequency of 8kHz.

PCM_CLK operates at a fixed clock frequency of 256kHz.

Bits 1 to 13 of the PCM_OUT data carry the current output sample value.

Bits 14 to 16 carry a three bit signal level value.

Reference PCM audio device is MC145483.

8. PIO PORT

The PIO port is general purpose IO interface and the ports consists of 8 programmable, Bi-directional PIO [0:7]. The maximum current drive capability is 4mA.

PIO [0], PIO [1] are recommended to be open if they are not used.

9. FCC Compliance and Advisory Statement

FCC Part 15.19)

This device complies with part 15 of the FCC Rules. Operation is subject to the following two conditions: (1) This device may not cause harmful interference, and (2) this device must accept any interference received, including interference that may cause undesired operation.

FCC Part 15.21 and 15.105)

Changes or modifications not expressly approved by the party responsible for compliance could void the user's authority to operate the equipment.

Note: This equipment has been tested and found to comply with the limits for a Class B digital device, pursuant to part 15 of the FCC Rules. These limits are designed to provide reasonable protection against harmful interference in a residential installation. This equipment generates, uses and can radiate radio frequency energy and, if not installed and used in accordance with the instructions, may cause harmful interference to radio communications. However, there is no guarantee that interference will not occur in a particular installation. If this equipment does cause harmful interference to radio or television reception, which can be determined by turning the equipment off and on, the user is encouraged to try to correct the interference by one or more of the following measures:--Reorient or relocate the receiving antenna.--Increase the separation between the equipment and receiver.--Connect the equipment into an outlet on a circuit different from that to which the receiver is connected. --Consult the dealer or an experienced radio/TV technician for help.

10. OVERALL APPEARANCE

Module without antenna WML-C05NX

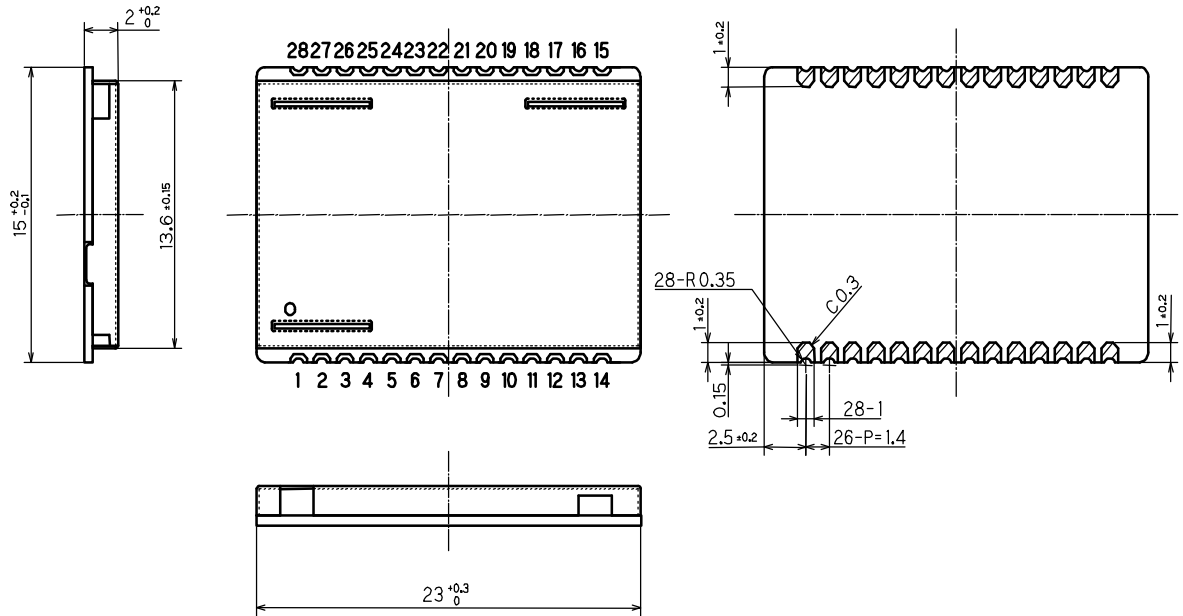

Module with antenna WML-C05AX

