

---

# SAR Test Report

---

Report No.: AGC092120801-1S1

**FCC ID** : PODTH-UV3R  
**Product Designation** : Two-way Radio  
**Brand Name** : TYT  
**Model Name** : TH-UV3R,TH-UV6R,TH-UV7R,TH-UV8R  
**Client** : TYT ELECTRONICS CO.,LTD  
**Date of Issue** : Mar.26, 2013  
**STANDARD(S)** : FCC Oet65 Supplement C June 2001  
IEEE Std. 1528-2003,47CFR § 2.1093

Attestation of Global Compliance (Shenzhen) Co., Ltd.

CAUTION: This report shall not be reproduced except in full without the written permission of the test laboratory and shall not be quoted out of context.

## Test Report Certification

Applicant Name	:	TYT ELECTRONICS CO.,LTD
Applicant Address	:	Block 39-1,Optoelectronics information industry base,Nan'an,quanzhou,Fujian
Manufacturer Name	:	TYT ELECTRONICS CO.,LTD
Manufacturer Address	:	Block 39-1,Optoelectronics information industry base,Nan'an,quanzhou,Fujian
Product Name	:	Two-way Radio
Brand Name	:	TYT
Model Name	:	TH-UV3R,TH-UV6R,TH-UV7R,TH-UV8R
Difference Description	:	They have the same PCB Board, Just difference with its appearance
EUT Voltage	:	DC3.6V by battery
Applicable Standard	:	FCC Oet65 Supplement C June 2001 IEEE Std. 1528-2003,47CFR § 2.1093
Test Date	:	Mar.25, 2013
Test Results	:	MAX SAR MEASUREMENT(1g) with 50% duty cycle V: Head: <b>0.332</b> W/Kg Body: <b>0.083</b> W/Kg (Scaling SAR= <b>0.333</b> W/Kg) U: Head: <b>3.861</b> W/Kg Body: <b>3.595</b> W/Kg (Scaling SAR= <b>3.880</b> W/Kg)
Performed Location	:	Attestation of Global Compliance (Shenzhen)Co., Ltd. 2F, Building 2, No.1-No.4, Chaxi Sanwei Technical Industrial Park, Gushu, Xixiang Street, Bao'an District, Shenzhen, China

Documented By

*Vivi Zeng*

Vivi Zeng Mar.26, 2013

Checked By

*Angela Li*

Angela Li Mar.26, 2013

Authorized By

*Solger Zhang*

Solger Zhang Mar.26, 2013

## TABLE OF CONTENTS

<b>1. GENERAL INFORMATION .....</b>	<b>4</b>
1.1. EUT Description .....	4
1.2. Test Procedure .....	5
1.3. Test Environment .....	5
<b>2. SAR MEASUREMENT SYSTEM.....</b>	<b>6</b>
2.1. COMOSAR System Description.....	6
2.2. COMOSAR E-Field Probe.....	8
2.3 Robot .....	8
2.4. Video Positioning System.....	9
2.5. Device Holder .....	9
2.6. Elliptic Phantom .....	10
<b>3. TISSUE SIMULATING LIQUID .....</b>	<b>11</b>
3.1. The composition of the tissue simulating liquid.....	11
3.2. Tissue Calibration Result.....	12
3.3. Tissue Dielectric Parameters for Head and Body Phantoms .....	13
<b>4. SAR MEASUREMENT PROCEDURE.....</b>	<b>14</b>
4.1. SAR System Validation .....	14
4.2. SAR Measurement Procedure .....	16
<b>5. SAR EXPOSURE LIMITS .....</b>	<b>17</b>
<b>6. TEST EQUIPMENT LIST .....</b>	<b>18</b>
<b>7. MEASUREMENT UNCERTAINTY .....</b>	<b>19</b>
<b>8. CONDUCTED POWER MEASUREMENT.....</b>	<b>20</b>
<b>9. TEST RESULTS .....</b>	<b>21</b>
<b>APPENDIX A. SAR SYSTEM VALIDATION DATA .....</b>	<b>24</b>
<b>APPENDIX B. SAR MEASUREMENT DATA.....</b>	<b>28</b>
<b>APPENDIX C. TEST SETUP PHOTOGRAPHS &amp;EUT PHOTOGRAPHS.....</b>	<b>52</b>
<b>APPENDIX D. PROBE CALIBRATION DATA .....</b>	<b>59</b>
<b>APPENDIX E. DIPOLE CALIBRATION DATA.....</b>	<b>69</b>

## 1. General Information

### 1.1. EUT Description

Product Name	Two-way Radio
Test Model	TH-UV3R
Hardware Version	TH-UV3R
Software Version	TH-UV3R
Exposure Category:	Occupational/Controlled Exposure
Device Category	FM UHF Portable Transceiver
Modulation Type	FM
TX Frequency Range	136-174MHz&400-470MHz
Rated Power	2.5Watt
Maximum Peak Power	VHF:33.89dBm UHF:33.83dBm
Channel Spacing	12.5 kHz
Antenna Type	External Antenna
Antenna Gain	2.15dB
Body-Worn Accessories:	Belt Clip with headset
Face-Head Accessories:	None
Battery Type (s) Tested:	DC3.6V by battery

*Note: The sample used for testing is end product.*

### 1.2. Test Procedure

1	Setup the EUT for two typical configuration of hold to face and body worn individually
2	Power on the EUT and make it continuously transmitting on required operating channel
3	Make sure the EUT work normally during the test

### 1.3. Test Environment

Ambient conditions in the laboratory:

Items	Required	Actual
Temperature (°C)	18-25	21 ± 2
Humidity (%RH)	30-70	56

## 2. SAR Measurement System

### 2.1. COMOSAR System Description

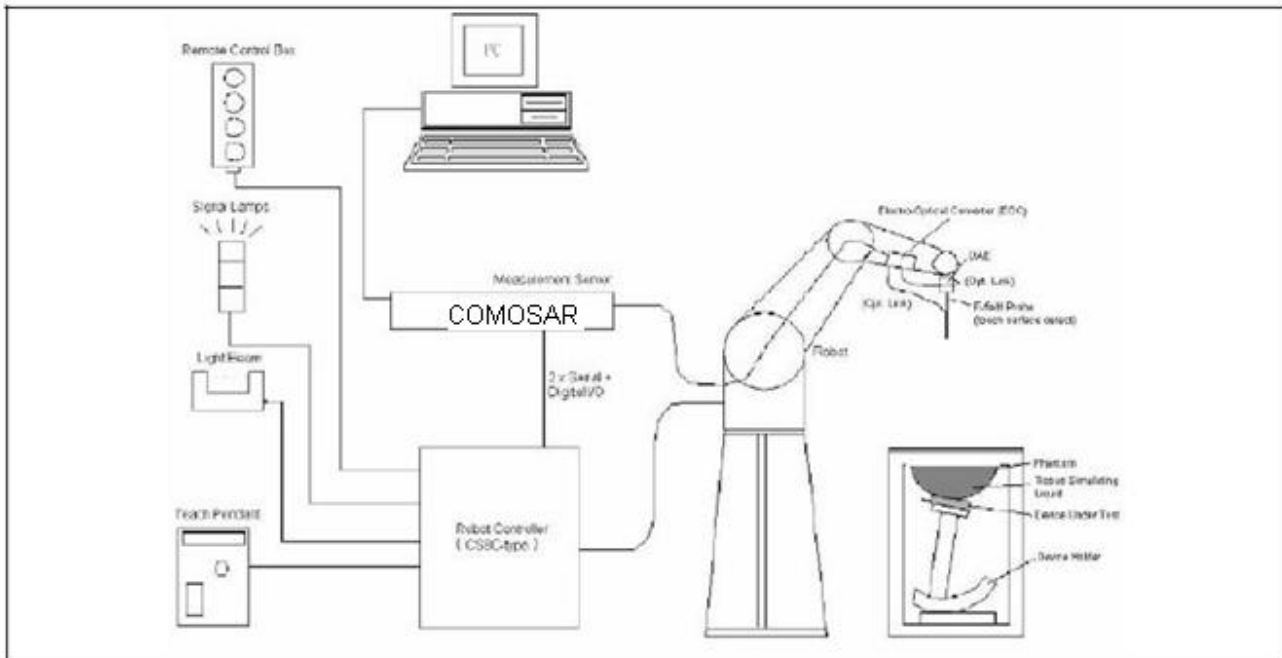

The COMOSAR system for performing compliance tests consists of the following items:

- A standard high precision 6-axis robot with controller, teach pendant and software. An arm extension for accommodating the data acquisition electronics (DAE).
- A data acquisition electronics (DAE) which performs the signal amplification, signal multiplexing, AD-conversion, offset measurements, mechanical surface detection, collision detection, etc. The unit is battery powered with standard or rechargeable batteries. The signal is optically transmitted to the EOC.
- The Electro-optical converter (EOC) performs the conversion from optical to electrical signals for the digital communication to the DAE. To use optical surface detection, a special version of the EOC is required. The EOC signal is transmitted to the measurement server.
- The Light Beam used is for probe alignment. This improves the (absolute) accuracy of the probe positioning.
- A computer running WinXP and the Opensar software.
- Remote control and teach pendant as well as additional circuitry for robot safety such as warning lamps, etc.
- The phantom, the device holder and other accessories according to the targeted measurement.

### 2.1.1. Applications

Predefined procedures and evaluations for automated compliance testing with all worldwide standards, e.g., IEEE 1528, OET 65, IEC 62209-1, IEC 62209-2, EN 50360, EN 50383 and others.

### 2.1.2. Area Scans

Area scans are defined prior to the measurement process being executed with a user defined variable spacing between each measurement point (integral) allowing low uncertainty measurements to be conducted. Scans defined for FCC applications utilize a 10mm<sup>2</sup> step integral, with 1mm interpolation used to locate the peak SAR area used for zoom scan assessments.

When an Area Scan has measured all reachable points, it computes the field maxima found in the scanned area, within a range of the global maximum. The range (in dB) is specified in the standards for compliance testing. For example, a 2 dB range is required in IEEE 1528-2003, EN 50361 and IEC 62209 standards, whereby 3 dB is a requirement when compliance is assessed in accordance with the ARIB standard (Japan).

### 2.1.3. Zoom Scan (Cube Scan Averaging)

Zoom Scans are used to assess the peak spatial SAR values within a cubic averaging volume containing 1 g and 10 g of simulated tissue. A density of 1000 kg/m<sup>3</sup> is used to represent the head and body tissue density and not the phantom liquid density, in order to be consistent with the definition of the liquid dielectric properties, i.e. the side length of the 1 g cube is 10mm, with the side length of the 10 g cube 21,5mm.

The zoom scan integer steps can be user defined so as to reduce uncertainty, but normal practice for typical test applications utilize a physical step of 7x7x7 (5mmx5mmx5mm) providing a volume of 30mm in the X & Y axis, and 30mm in the Z axis.

### 2.1.4. Uncertainty of Inter-/Extrapolation and Averaging

In order to evaluate the uncertainty of the interpolation, extrapolation and averaged SAR calculation algorithms of the Post processor, COMOSAR allows the generation of measurement grids which are artificially predefined by analytically based test functions. Therefore, the grids of area scans and zoom scans can be filled with uncertainty test data, according to the SAR benchmark functions of IEEE 1528. The three analytical functions shown in equations as below are used to describe the possible range of the expected SAR distributions for the tested handsets. The field gradients are covered by the spatially flat distribution f1, the spatially steep distribution f3 and f2 accounts for H-field cancellation on the phantom/tissue surface.

$$f_1(x, y, z) = Ae^{-\frac{z}{2a}} \cos^2 \left( \frac{\pi}{2} \frac{\sqrt{x'^2 + y'^2}}{5a} \right)$$

$$f_2(x, y, z) = Ae^{-\frac{z}{a}} \frac{a^2}{a^2 + x'^2} \left( 3 - e^{-\frac{2z}{a}} \right) \cos^2 \left( \frac{\pi}{2} \frac{y'}{3a} \right)$$

$$f_3(x, y, z) = A \frac{a^2}{\frac{a^2}{4} + x'^2 + y'^2} \left( e^{-\frac{2z}{a}} + \frac{a^2}{2(a + 2z)^2} \right)$$

## 2.2. COMOSAR E-Field Probe

The SAR measurement is conducted with the dissymmetric probe manufactured by SPEAG.

The probe is specially designed and calibrated for use in liquid with high permittivity. The dissymmetric probe has special calibration in liquid at different frequency.

SPEAG conducts the probe calibration in compliance with international and national standards (e.g. IEEE 1528, EN62209-1, IEC 62209, etc.) Under ISO17025. The calibration data are in Appendix D.

### 2.2.1. Isotropic E-Field Probe Specification

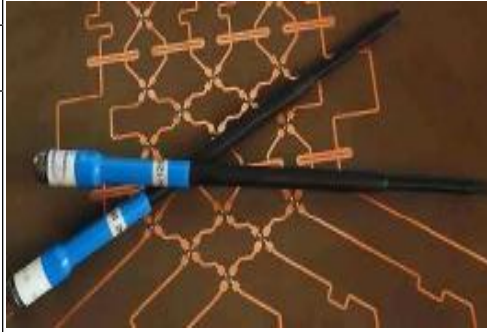
<b>Model</b>	EP165	
<b>Manufacture</b>	Satimo	
<b>frequency</b>	0.03GHz-3 GHz Linearity:±0.2dB(30 MHz-3 GHz)	
<b>Dynamic Range</b>	0.01W/Kg-100W/Kg Linearity:±0.2dB	
<b>Dimensions</b>	Overall length:330mm Length of individual dipoles:4.5mm Maximum external diameter:8mm Probe Tip external diameter:5mm Distance between dipoles/ probe extremity:2.7mm	
<b>Application</b>	High precision dosimetric measurements in any exposure scenario (e.g., very strong gradient fields). Only probe which enables compliance testing for frequencies up to 3 GHz with precision of better 30%.	

## 2.3 Robot

The COMOSAR system uses the high precision robots TX90 XL type out of the newer series from Satimo SA (France). For the 6-axis controller COMOSAR system, the KUKA robot controller version from Satimo is used.

The XL robot series have many features that are important for our application:

- High precision (repeatability 0.02 mm)
- High reliability (industrial design)
- Jerk-free straight movements
- Low ELF interference (the closed metallic construction shields against motor control fields)
- 6-axis controller





## 2.4. Video Positioning System

The video positioning system is used in OpenSAR to check the probe. Which is composed of a camera, LED, mirror and mechanical parts. The camera is piloted by the main computer with firmware link.

During the process, the actual position of the probe tip with respect to the robot arm is measured, as well as the probe length and the horizontal probe offset. The software then corrects all movements, such that the robot coordinates are valid for the probe tip.

The repeatability of this process is better than 0.1 mm. If a position has been taught with an aligned probe, the same position will be reached with another aligned probe within 0.1 mm, even if the other probe has different dimensions. During probe rotations, the probe tip will keep its actual position.



## 2.5. Device Holder

The COMOSAR device holder is designed to cope with different positions given in the standard. It has two scales for the device rotation (with respect to the body axis) and the device inclination (with respect to the line between the ear reference points). The rotation center for both scales is the ear reference point (EPR).

Thus the device needs no repositioning when changing the angles.

The COMOSAR device holder has been made out of low-loss POM material having the following dielectric parameters: relative permittivity  $\epsilon_r = 3$  and loss tangent  $\delta = 0.02$ . The amount of dielectric material has been reduced in the closest vicinity of the device, since measurements have suggested that the influence of the clamp on the test results could thus be lowered.

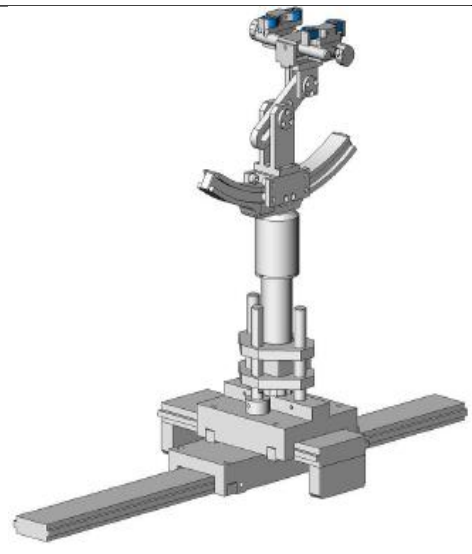

## 2.6. Elliptic Phantom

The Elliptic Phantom is a fiberglass shell flat phantom with 2mm+/- 0.2 mm shell thickness. It has only one measurement area for Flat phantom



### 3. Tissue Simulating Liquid

#### 3.1. The composition of the tissue simulating liquid

Ingredient (% Weight) Tissue Type	300MHz	450 MHz
Water	37.56	38.56
Salt (NaCl)	5.95	3.95
Sugar	55.32	56.32
HEC	0.98	0.98
Bactericide	0.19	0.19
Triton X-100	0.0	0.0
DGBE	0.0	0.0

### 3.2. Tissue Calibration Result

The dielectric parameters of the liquids were verified prior to the SAR evaluation using COMOSAR Dielectric Probe Kit and R&S Network Analyzer ZVL6 .

Head Tissue Stimulant Measurement				
Frequency (MHz)	Description	Dielectric Parameters		Tissue Temp [°C]
300MHz	Reference result ±5% window	$\epsilon_r$ 45.30 43.035 -47.565	$\delta$ [s/m] 0.87 0.8265 - 0.9135	N/A
	Mar.25, 2013	44.96	0.89	21.0

Body Tissue Stimulant Measurement				
Frequency (MHz)	Description	Dielectric Parameters		Tissue Temp [°C]
300MHz	Reference result ±5% window	$\epsilon_r$ 58.2 55.29 - 61.11	$\delta$ [s/m] 0.92 0.874 - 0.966	N/A
	Mar.25, 2013	57.72	0.91	21.0

Head Tissue Stimulant Measurement				
Frequency (MHz)	Description	Dielectric Parameters		Tissue Temp [°C]
450 MHz	Reference result ±5% window	$\epsilon_r$ 43.50 41.325 - 45.675	$\delta$ [s/m] 0.87 0.8265 - 0.9135	N/A
	Mar.25, 2013	43.56	0.91	21.0

Body Tissue Stimulant Measurement				
Frequency (MHz)	Description	Dielectric Parameters		Tissue Temp [°C]
450 MHz	Reference result ±5% window	$\epsilon_r$ 56.7 53.865 - 59.535	$\delta$ [s/m] 0.94 0.893 - 0.987	N/A
	Mar.25, 2013	56.82	0.96	21.0

### 3.3. Tissue Dielectric Parameters for Head and Body Phantoms

The head tissue dielectric parameters recommended by the IEEE SCC-34/SC-2 in P1528 have been incorporated in the following table. These head parameters are derived from planar layer models simulating the highest expected SAR for the dielectric properties and tissue thickness variations in a human head. Other head and body tissue parameters that have not been specified in P1528 are derived from the tissue dielectric parameters computed from the 4-Cole-Cole equations described in Reference [12] and extrapolated according to the head parameters specified in P1528.

Target Frequency (MHz)	head		body	
	$\epsilon_r$	$\sigma$ (S/m)	$\epsilon_r$	$\sigma$ (S/m)
<b>300</b>	<b>45.3</b>	<b>0.87</b>	<b>58.2</b>	<b>0.92</b>
<b>450</b>	<b>43.5</b>	<b>0.87</b>	<b>56.7</b>	<b>0.94</b>
835	41.5	0.90	55.2	0.97
900	41.5	0.97	55.0	1.05
915	41.5	0.98	55.0	1.06
1450	40.5	1.20	54.0	1.30
1610	40.3	1.29	53.8	1.40
1800 – 2000	40.0	1.40	53.3	1.52
2450	39.2	1.80	52.7	1.95
3000	38.5	2.40	52.0	2.73
5800	35.3	5.27	48.2	6.00

(  $\epsilon_r$  = relative permittivity,  $\sigma$  = conductivity and  $\rho = 1000 \text{ kg/m}^3$ )

## 4. SAR Measurement Procedure

### 4.1. SAR System Validation

#### 4.1.1. Validation Dipoles

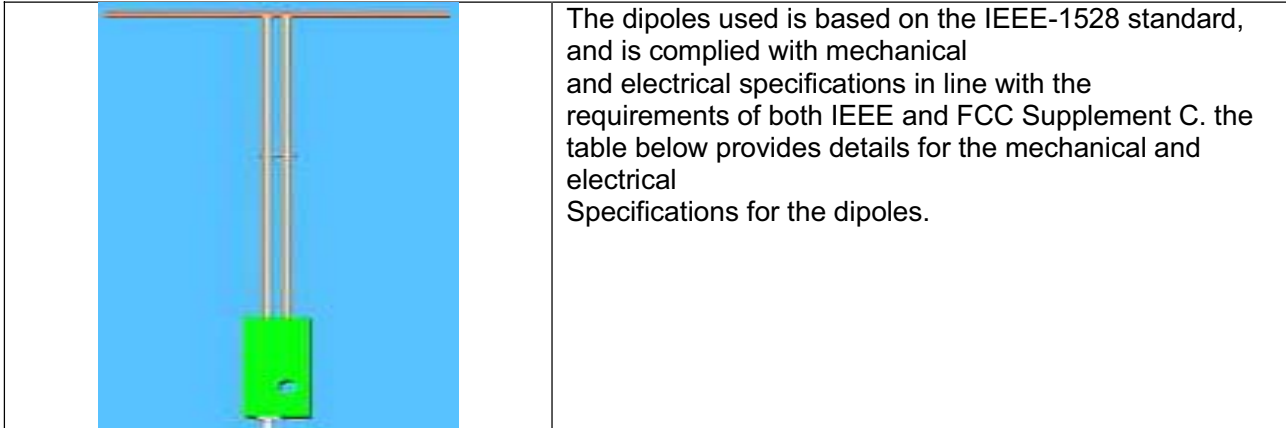

Frequency	L (mm)	h (mm)	d (mm)
300MHz	420	290	6.36
450MHz	290	166.7	6.35

#### 4.1.2. Validation Result

<b>System Performance Check at 300 MHz for Head</b>				
<b>Validation Kit: SN 46/11DIP 0G300-183</b>				
Frequency [MHz]	Description	SAR [w/kg] 1g	SAR [w/kg] 10g	Tissue Temp.[°C]
300 MHz	Reference result ± 10% window	2.85 2.565 to 3.135	1.94 1.746 to 2.134	N/A
	Mar.25, 2013	2.98	1.91	21
Note: All SAR values are normalized to 1W forward power.				

<b>System Performance Check at 450 MHz for Head Liquid</b>				
<b>Validation Kit: SN 46/11 DIP 0G450-184</b>				
Frequency	Description	SAR [w/kg] 1g	SAR [w/kg] 10g	Tissue Temp.[°C]
450 MHz	Reference result ± 10% window	4.58 4.122 to 5.038	3.06 2.754 to 3.366	N/A
	Mar.25, 2013	4.57	2.96	21
Note: All SAR values are normalized to 1W forward power.				

## 4.2. SAR Measurement Procedure

The COMOSAR calculates SAR using the following equation,

$$SAR = \frac{\sigma |E|^2}{\rho}$$

$\sigma$ : represents the simulated tissue conductivity

$\rho$ : represents the tissue density

The EUT is set to transmit at the required power in line with product specification, at each frequency relating to the LOW, MID, and HIGH channel settings.

Pre-scans are made on the device to establish the location for the transmitting antenna, using a large area scan in either air or tissue simulation fluid.

The EUT is placed against the Universal Phantom where the maximum area scan dimensions are larger than the physical size of the resonating antenna. When the scan size is not large enough to cover the peak SAR distribution, it is modified by either extending the area scan size in both the X and Y directions, or the device is shifted within the predefined area.

The area scan is then run to establish the peak SAR location (interpolated resolution set at  $1\text{mm}^2$ ) which is then used to orient the center of the zoom scan. The zoom scan is then executed and the 1g and 10g averages are derived from the zoom scan volume (interpolated resolution set at  $1\text{mm}^3$ ).

When multiple peak SAR locations were found during the same configuration or test mode, Zoom scan shall performed on each peak SAR location, only the peak point with maximum SAR value will be reported for the configuration or test mode.



## 5. SAR Exposure Limits

SAR assessments have been made in line with the requirements of IEEE-1528, FCC Supplement C, and comply with ANSI/IEEE C95.1-1992 “Uncontrolled Environments” limits. These limits apply to a location which is deemed as “Uncontrolled Environment” which can be described as a situation where the general public may be exposed to an RF source with no prior knowledge or control over their exposure.

### Limits for General Population/Uncontrolled and Occupational Environment

Type Exposure Limits	General Population / Uncontrolled Environment Limit (W/Kg)	Occupational / Controlled Exposure Environment (W/Kg)
Spatial Average SAR (whole body)	1.60	8.0

## 6. Test Equipment List

Equipment description	Manufacturer/Model	Identification No.	Current calibration date	Next calibration date
SAR Probe	Satimo	SN 04/13 EP165	01/31/2013	01/30/2014
Phantom	Satimo	SN_4511_SAM90	Validated. No cal required.	Validated. No cal required.
Liquid	Satimo	-	Validated. No cal required.	Validated. No cal required.
Comm Tester	R&S - CMU200	069Y7-158-13-712	02/28/2013	02/27/2014
Multimeter	Keithley 2000	1188656	02/28/2013	02/27/2014
Dipole	Satimo SID300	SN 46/11DIP 0G300-183	12/09/2011	12/08/2013
Dipole	Satimo SID450	SN46/11 DIP 0G450-184	12/09/2011	12/08/2013
Amplifier	Aethercomm	SN 046	12/08/2012	12/07/2013
Signal Generator	Agilent-E4421B	MY43351603	05/29/2012	05/28/2013
Power Meter	HP E4418A	US38261498	02/28/2013	02/27/2014
Network Analyzer	Rhode & Schwarz ZVA	SN100132	02/28/2013	02/27/2014

Note: Per KDB 50824 Dipole SAR Validation Verification, AGC Lab has adopted 3 years calibration intervals. On annual basis, every measurement dipole has been evaluated and is in compliance with the following criteria:

1. There is no physical damage on the dipole;
2. System validation with specific dipole is within 10% of calibrated value;
3. Return-loss is within 20% of calibrated measurement;
4. Impedance is within 5Ω of calibrated measurement.

## 7. Measurement Uncertainty

### Satimo Uncertainty

Measurement uncertainty for 300 MHz to 6 GHz averaged over 1 gram / 10 gram.

Error Description	Sec	Tol (±%)	Prob. Dist.	Div.	(Ci) 1g	(Ci) 10g	Std. Unc. (1g) (±%)	Std. Unc. (10g)(±%)	(Vi) Veff
<b>Measurement System</b>									
Probe Calibration	E.2.1	6	N	1	1	1	6	6	∞
Axial Isotropy	E.2.2	3	R	$\sqrt{3}$	$(1-c_p)^{1/2}$	$(1-c_p)^{1/2}$	1.22474	1.22474	∞
Hemispherical Isotropy	E.2.2	5	R	$\sqrt{3}$	$\sqrt{c_p}$	$\sqrt{c_p}$	2.04124	2.04124	∞
Boundary Effects	E.2.3	1	R	$\sqrt{3}$	1	1	0.57735	0.57735	∞
Linearity	E.2.4	5	R	$\sqrt{3}$	1	1	2.88675	2.88675	∞
System Detection Limits	E.2.5	1	R	$\sqrt{3}$	1	1	0.57735	0.57735	∞
Readout Electronics	E.2.6	0.5	N	1	1	1	0.5	0.5	∞
Response Time	E.2.7	0.2	R	$\sqrt{3}$	1	1	0.11547	0.11547	∞
Integration Time	E.2.8	2	R	$\sqrt{3}$	1	1	1.1547	1.1547	∞
RF Ambient Noise	E.6.1	3	R	$\sqrt{3}$	1	1	1.73205	1.73205	∞
Probe Positioner Mechanical Tolerance	E.6.2	2	R	$\sqrt{3}$	1	1	1.1547	1.1547	∞
Probe Positioning with Respect to Phantom Shell	E.6..3	1	R	$\sqrt{3}$	1	1	0.57735	0.57735	∞
Extrapolation,interpolation and Integration Algorithms for Max. SAR Evaluation	E.5.2	1.5	R	$\sqrt{3}$	1	1	0.89603	0.89603	∞
<b>Dipole</b>									
Device Positioning	8,E.4.2	1	N	$\sqrt{3}$	1	1	0.57735	0.57735	N-1
Power Drift	8.6.6.2	2	R	$\sqrt{3}$	1	1	1.1547	1.1547	∞
<b>Phantom and Tissue Parameters</b>									
Phantom Uncertainty	E.3.1	4	R	$\sqrt{3}$	1	1	2.3094	2.3094	∞
Liquid Conductivity (target)	E.3.2	5	R	$\sqrt{3}$	0.64	0.43	1.84752	1.2413	∞
Liquid Conductivity (meas.)	E.3.3	2.5	N	1	0.64	0.43	1.6	1.075	∞
Liquid Permittivity (target)	E.3.2	3	R	$\sqrt{3}$	0.6	0.49	1.03923	0.8487	∞
Liquid Permittivity (meas.)	E.3.3	2.5	N	1	0.6	0.49	1.5	1.225	M
Combined Standard Uncertainty			RSS				8.09272	7.9296	
Expanded Uncertainty (95%CONFIDENCE INTERVAL)			k				16.18544	15.8594	

## 8. Conducted Power Measurement

Frequency (MHz)	Channel Spacing	Measured Conducted Output power	
		Max. Peak Power (dBm)	Avg. Power (dBm)
136.025	12.5KHz	33.85	33.62
155.000		<b>33.89</b>	33.74
173.975		33.82	33.59

Frequency (MHz)	Channel Spacing	Measured Conducted Output power	
		Max. Peak Power (dBm)	Avg. Power (dBm)
407.625	12.5KHz	33.69	30.42
435.325		<b>33.83</b>	30.51
469.975		33.67	30.39

## **9. Test Results**

### **9.1. SAR Test Results Summary**

#### **9.1.1. Test position and configuration**

Head SAR was performed with the device configured in the positions according to KDB 643646 and Body SAR was performed with the device configured with all accessories close to the Flat Phantom.

#### **9.1.2. Operation Mode**

Set the EUT to maximum output power level and transmit on lower, middle and top channel with 100% duty cycle individually during SAR measurement.

#### **9.1.3. Co-located SAR**

The following KDB was used for assessing this device.  
KDB 447498, KDB 643646 and KDB450824

### 9.1.4. Test Result

SAR MEASUREMENT							
Ambient Temperature (°C) : 21 ±2				Relative Humidity (%) : 52			
Liquid Temperature (°C) : 21 ±2				Depth of Liquid (cm):>15			
Product: Two-way Radio							
Test Mode: Hold to Face with 2.5 cm separation(VHF)							
Test Position	Frequency			Power Drift (±0.2dB)	SAR 1g with 100% duty Cycle (W/kg)	SAR 1g with 50% duty cycle (W/Kg)	Limit (W/kg)
	channel	MHz	Separation (KHz)				
Face Up	Low	136.025	12.5	-0.04	0.343	0.172	8.0
Face Up	Middle	155.000	12.5	-0.02	0.663	<b>0.332</b>	8.0
Face Up	Top	173.975	12.5	-0.05	0.225	0.113	8.0
Note: when the 1-g SAR of middle channel is ≤ 3.5 W/kg, testing for other channel is optional. refer to KDB 643646.							

SAR MEASUREMENT							
Ambient Temperature (°C) : 21 ±2				Relative Humidity (%) : 52			
Liquid Temperature (°C) : 21 ±2				Depth of Liquid (cm):>15			
Product: Two-way Radio							
Test Mode: Body worn with all accessories(VHF)							
Test Position	Frequency			Power Drift (±0.2dB)	SAR 1g with 100% duty Cycle (W/kg)	SAR 1g with 50% duty cycle (W/Kg)	Limit (W/kg)
	channel	MHz	Separation (KHz)				
Back Touch	Low	136.025	12.5	-0.02	0.142	0.071	8.0
Back Touch	Middle	155.000	12.5	-0.01	0.166	<b>0.083</b>	8.0
Back Touch	Top	173.975	12.5	0.03	0.131	0.066	8.0
Note: when the 1-g SAR of middle channel is ≤ 3.5 W/kg, testing for other channel is optional. refer to KDB 643646.							

SAR MEASUREMENT							
Ambient Temperature (°C) : 21 ±2				Relative Humidity (%): 52			
Liquid Temperature (°C) : 21 ±2				Depth of Liquid (cm):>15			
Product: Two-way Radio							
Test Mode: Hold to Face with 2.5 cm separation(UHF)							
Test Position	Frequency			Power Drift (±0.2dB)	SAR 1g with 100% duty Cycle (W/kg)	SAR 1g with 50% duty cycle (W/Kg)	Limit (W/kg)
	channel	MHz	Separation (KHz)				
Face Up	Low	407.625	12.5	0.05	7.722	<b>3.861</b>	8.0
Face Up	Middle	435.325	12.5	-0.02	7.515	3.758	8.0
Face Up	Top	469.975	12.5	0.04	5.871	2.934	8.0
Note: when the 1-g SAR of middle channel is ≤ 3.5 W/kg, testing for other channel is optional. refer to KDB 643646.							

SAR MEASUREMENT							
Ambient Temperature (°C) : 21 ±2				Relative Humidity (%): 52			
Liquid Temperature (°C) : 21 ±2				Depth of Liquid (cm):>15			
Product: Two-way Radio							
Test Mode: Body worn with all accessories(UHF)							
Test Position	Frequency			Power Drift (±0.2dB)	SAR 1g with 100% duty Cycle (W/kg)	SAR 1g with 50% duty cycle (W/Kg)	Limit (W/kg)
	channel	MHz	Separation (KHz)				
Back Touch	Low	407.625	12.5	0.03	2.050	1.025	8.0
Back Touch	Middle	435.325	12.5	0.02	7.189	<b>3.595</b>	8.0
Back Touch	Top	469.975	12.5	0.01	6.693	3.347	8.0
Note: when the 1-g SAR of middle channel is ≤ 3.5 W/kg, testing for other channel is optional. refer to KDB 643646.							

### Appendix A. SAR System Validation Data

Test Laboratory: AGC Lab

Test date: Mar.25, 2013

System Check Head 300MHz

DUT: Dipole 300 MHz Type: SID 300

Communication System: CW; Communication System Band: CW 300MHz; Duty Cycle: 1:1; Conv.F=4.58

Frequency: 300MHz; Medium parameters used:  $f = 300\text{MHz}$ ;  $\sigma = 0.89\text{mho/m}$ ;  $\epsilon_r = 44.96$ ;  $\rho = 1000 \text{ kg/m}^3$  ;

Phantom Type: Elliptical Phantom; Input Power=20dBm

Ambient temperature ( °C ): 21.0, Liquid temperature (°C): 21.0

Satimo Configuration:

Probe: EP165; Calibrated: 01/31/2013

- Sensor-Surface: 4mm (Mechanical Surface Detection)
- Phantom: Flat Phantom; Type: Elliptical Phantom
- Measurement SW: OpenSAR V4\_02\_0

Configuration/System Check CW 300MHz Head/Area Scan: Measurement grid: dx=8mm,dy=8mm

Configuration/System Check CW 300MHz Head/Zoom Scan : Measurement grid: dx=8mm, dy=8mm, dz=5mm

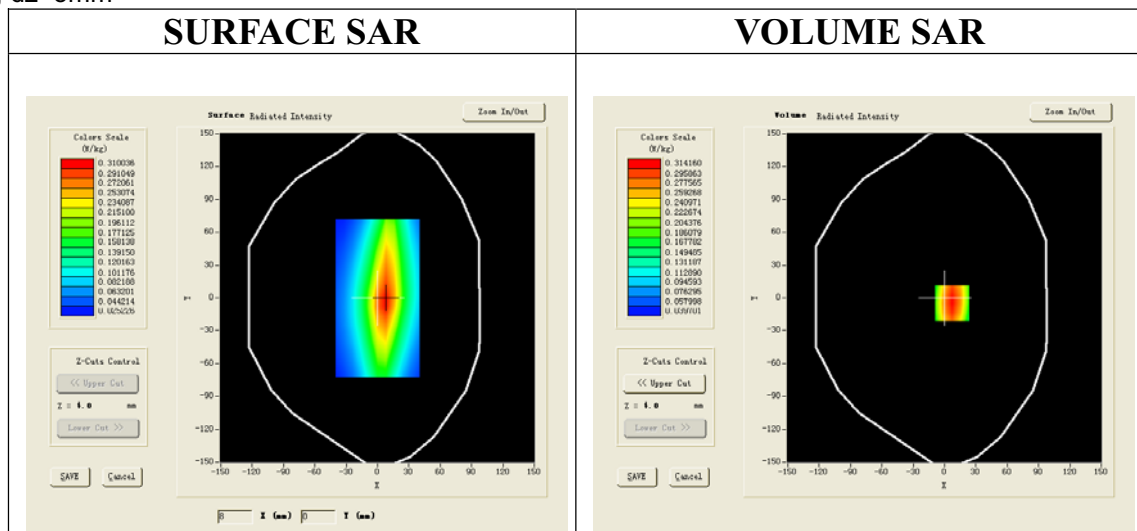

**Maximum location: X=7.00, Y=-5.00**

<b>SAR 10g (W/Kg)</b>	0.190634
<b>SAR 1g (W/Kg)</b>	0.297562



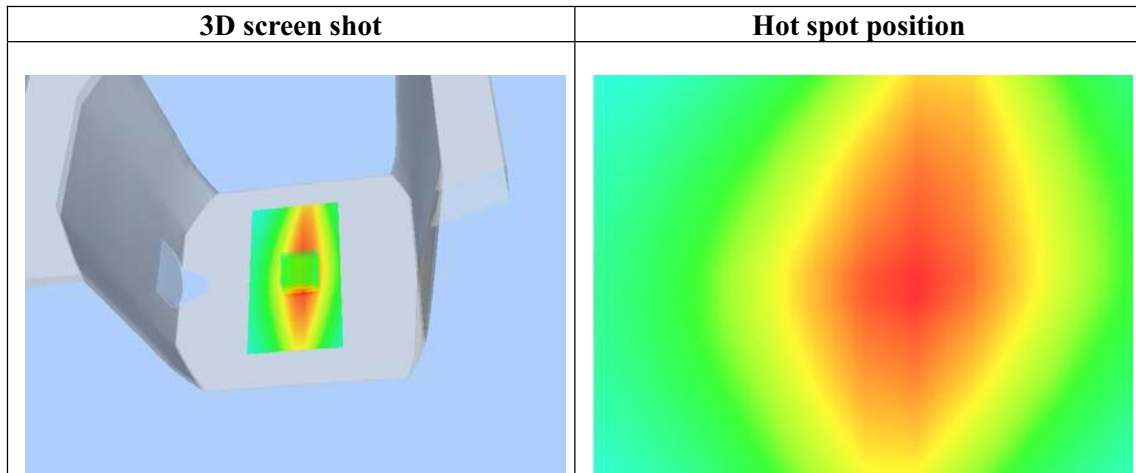
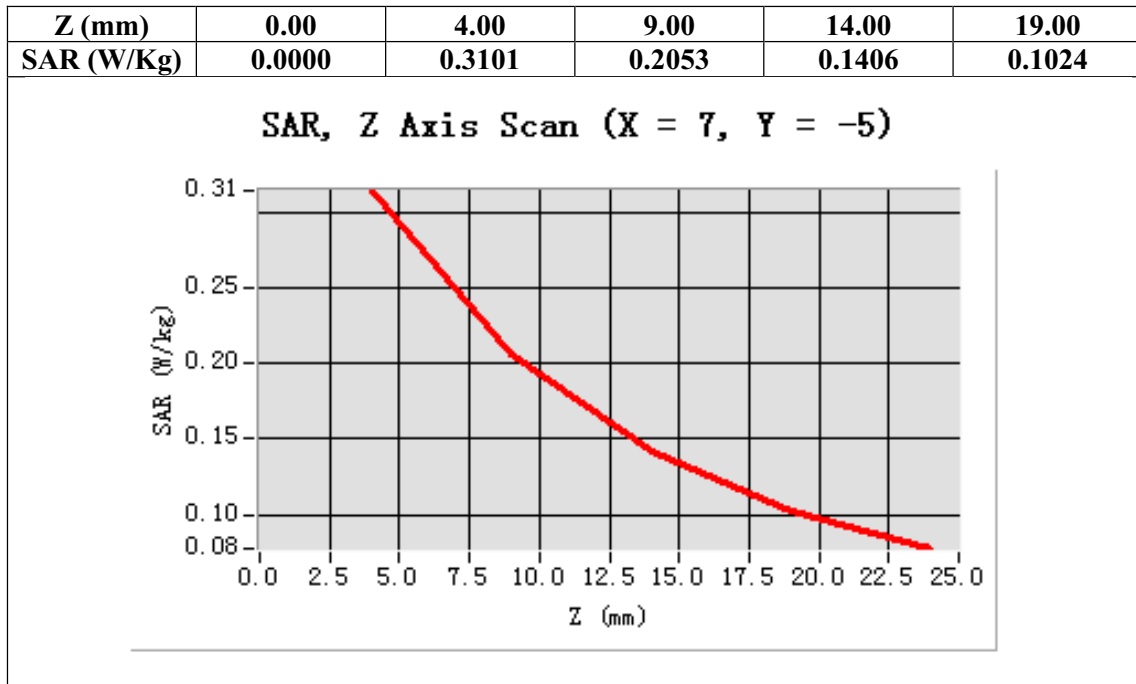

Test Laboratory: AGC Lab  
System Check Head 450MHz

Test date: Mar.25, 2013

DUT: Dipole 450 MHz Type: SID 450

Communication System: CW; Communication System Band: CW 450.0 MHz; Duty Cycle: 1:1; Conv.F=4.75  
Frequency: 450 MHz; Medium parameters used:  $f = 450$  MHz;  $\sigma = 0.91$  mho/m;  $\epsilon_r = 43.56$ ;  $\rho = 1000$  kg/m<sup>3</sup> ;  
Phantom Type: Elliptical Phantom; Input Power=10dBm  
Ambient temperature ( °C ): 21.0, Liquid temperature ( °C ): 21.0

Satimo Configuration:

Probe: EP165; Calibrated: 01/31/2013

- Sensor-Surface: 4mm (Mechanical Surface Detection)
- Phantom: Flat Phantom; Type: Elliptical Phantom
- Measurement SW: OpenSAR V4\_02\_0

Configuration/System Check CW 450 MHz Head/Area Scan: Measurement grid: dx=8mm,dy=8mm

Configuration/System Check CW 450 MHz Head/Zoom Scan : Measurement grid: dx=8mm, dy=8mm, dz=5mm,

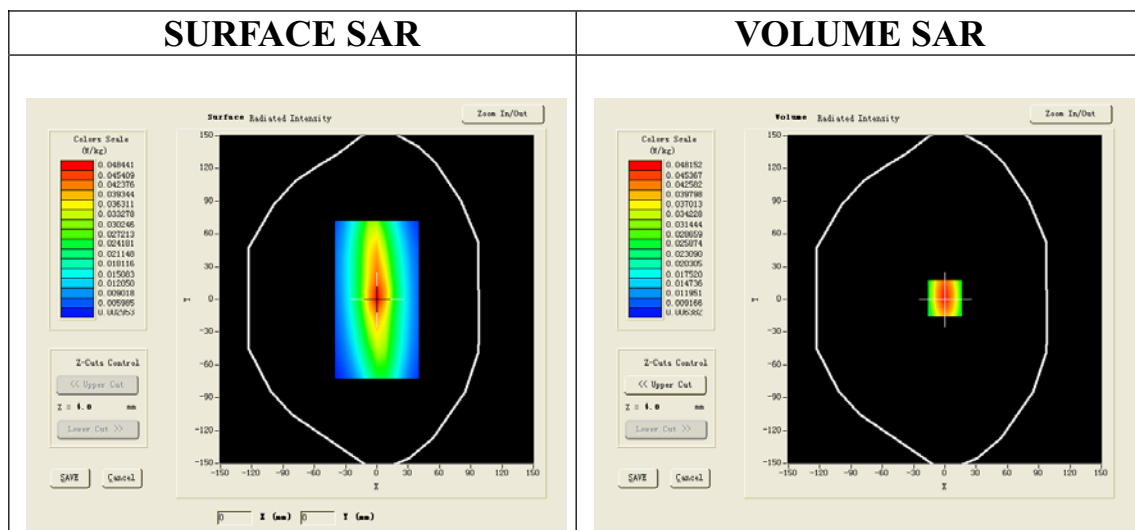

Maximum location: X=0.00, Y=1.00

SAR 10g (W/Kg)	0.029552
SAR 1g (W/Kg)	0.045734

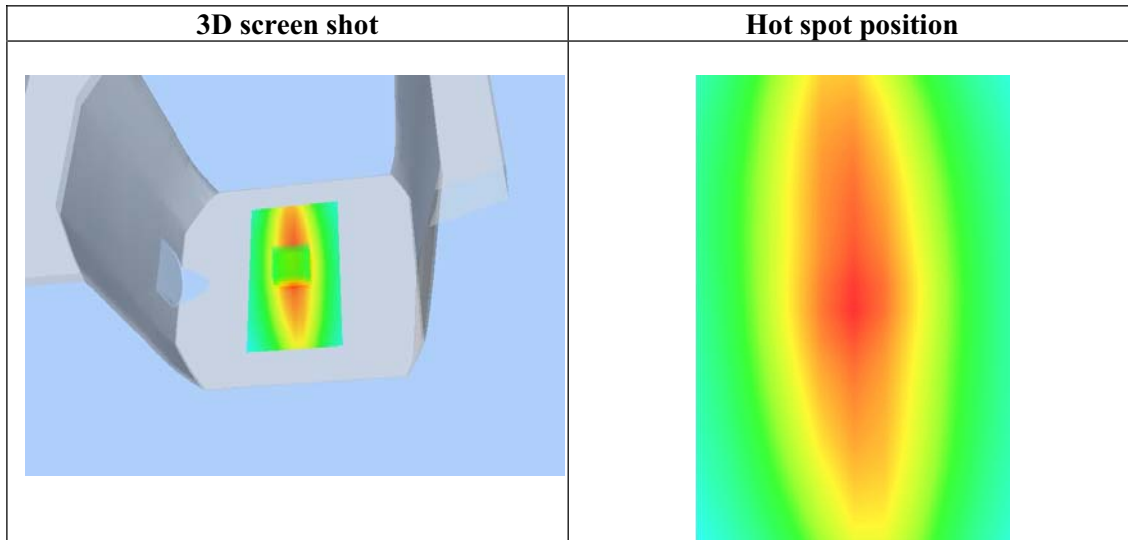
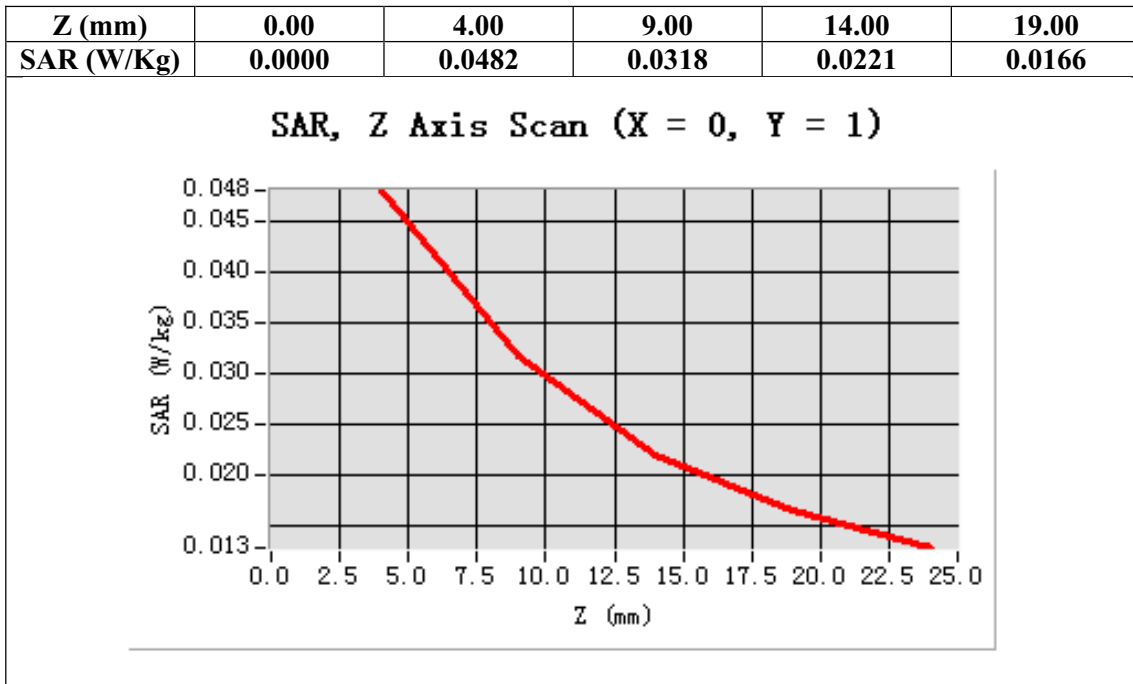

## Appendix B. SAR measurement Data

Test Laboratory: AGC Lab  
CW300Low-face up 2.5cm

Test date: Mar.25, 2013

DUT: Two-way Radio; Type: TH-UV3R

Communication System: CW; Communication System Band: CW 136.025 MHz; Duty Cycle: 1:1; Conv.F=4.58  
Frequency: 136.025 MHz; Medium parameters used:  $f = 300\text{MHz}$ ;  $\sigma = 0.89\text{mho/m}$ ;  $\epsilon_r = 44.96$ ;  $\rho = 1000 \text{ kg/m}^3$  ;  
Phantom Type: Elliptical Phantom  
Ambient temperature ( $^{\circ}\text{C}$ ): 21.5, Liquid temperature ( $^{\circ}\text{C}$ ): 21.0

Satimo Configuration:

Probe: EP165; Calibrated: 01/31/2013

- Sensor-Surface: 4mm (Mechanical Surface Detection)
- Phantom: Flat Phantom; Type: Elliptical Phantom
- Measurement SW: OpenSAR V4\_02\_0

Configuration/CW 300 Low/Area Scan (6x8x1): Measurement grid: dx=20mm, dy=20mm

Configuration/CW 300 Low /Zoom Scan (5x5x7)/Cube 0: Measurement grid: dx=8mm,dy=8mm, dz=5mm

Area Scan	ep_direct_droit2_surf8mm.txt
Zoom Scan	5x5x7,dx=8mm dy=8mm dz=5mm,Very fast
Phantom	Elliptical Phantom
Device Position	Face up 2.5 cm separation to Phantom
Band	CW 136.025MHz
Channels	Low
Signal	Crest factor: 1

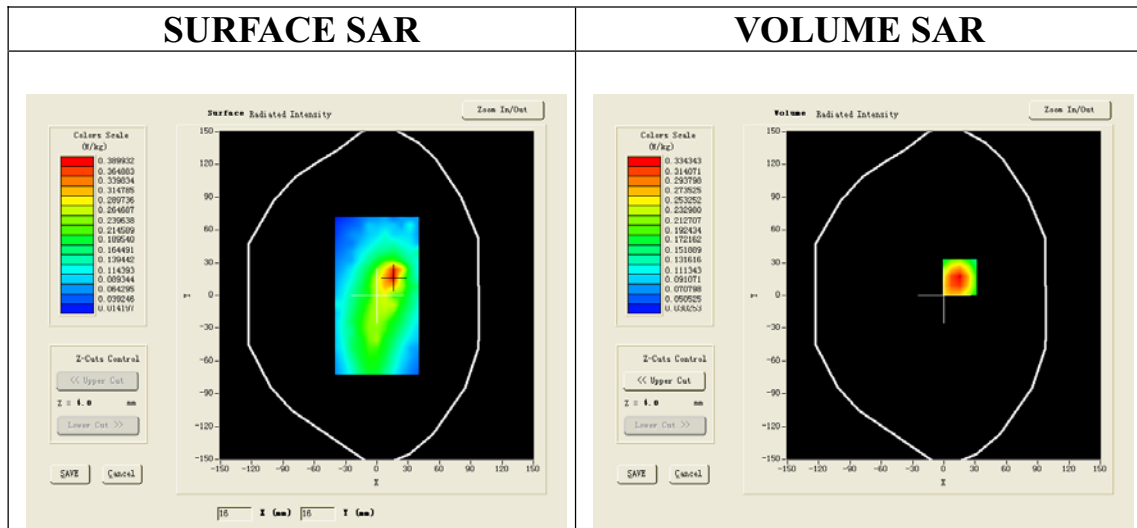

Maximum location: X=15.00, Y=17.00

SAR 10g (W/Kg)	0.211304
SAR 1g (W/Kg)	0.343144

<b>Z (mm)</b>	<b>0.00</b>	<b>4.00</b>	<b>9.00</b>	<b>14.00</b>	<b>19.00</b>
<b>SAR (W/Kg)</b>	<b>0.0000</b>	<b>0.3336</b>	<b>0.2085</b>	<b>0.1375</b>	<b>0.0976</b>

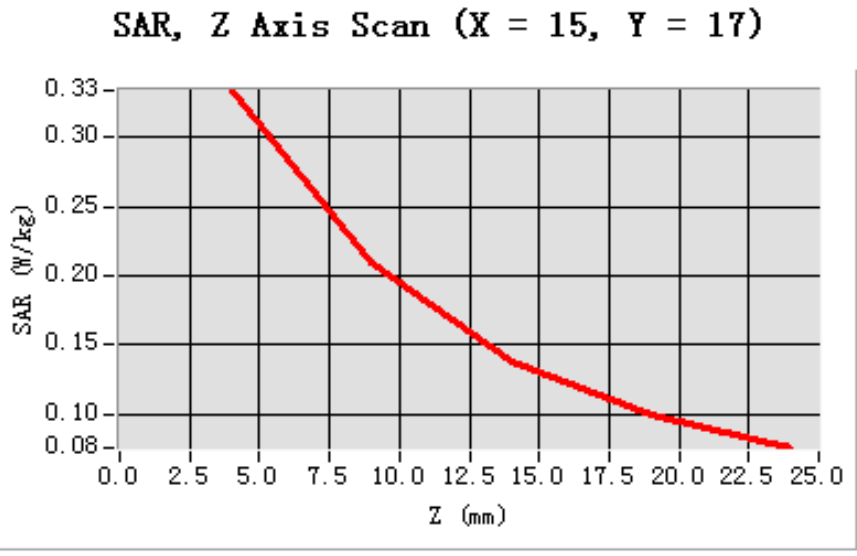

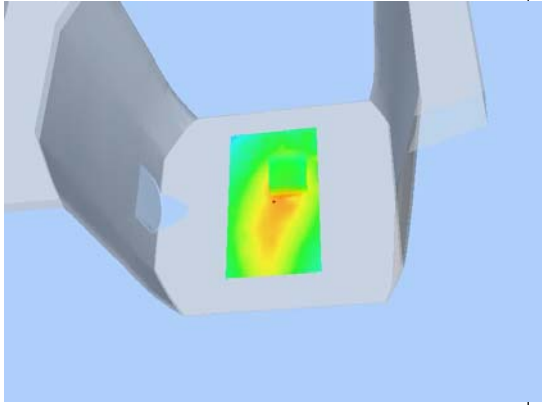
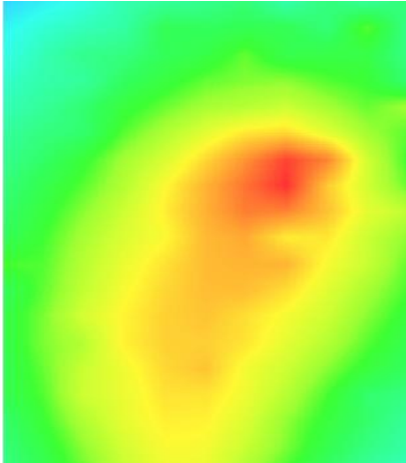
3D screen shot	Hot spot position
	

Test Laboratory: AGC Lab

Test date: Mar.25, 2013

CW300Middle- face up 2.5cm

**DUT: Two-way Radio; Type: TH-UV3R**

Communication System: CW; Communication System Band: CW155.000 MHz; Duty Cycle: 1:1; Conv.F=4.58  
Frequency:155.000 MHz; Medium parameters used:  $f = 300\text{MHz}$ ;  $\sigma = 0.89\text{mho/m}$ ;  $\epsilon_r = 44.96$ ;  $\rho = 1000 \text{ kg/m}^3$  ;

Phantom Type: Elliptical Phantom

Ambient temperature ( $^{\circ}\text{C}$ ): 21.5, Liquid temperature ( $^{\circ}\text{C}$ ): 21.0

Satimo Configuration:

Probe: EP165; Calibrated: 01/31/2013

- Sensor-Surface: 4mm (Mechanical Surface Detection)
- Phantom: Flat Phantom; Type: Elliptical Phantom
- Measurement SW: OpenSAR V4\_02\_0

**Configuration/CW 300 Mid /Area Scan (6x8x1):** Measurement grid: dx=20mm, dy=20mm

**Configuration/CW 300 Mid /Zoom Scan (5x5x7)/Cube 0:** Measurement grid: dx=8mm, dy=8mm,dz=5mm;

<b>Area Scan</b>	ep_direct_droit2_surf8mm.txt
<b>ZoomScan</b>	5x5x7,dx=8mm dy=8mm dz=5mm,Very fast
<b>Phantom</b>	Elliptical Phantom
<b>Device Position</b>	Face up 2.5 cm separation to Phantom
<b>Band</b>	CW 155.000 MHz
<b>Channels</b>	Middle
<b>Signal</b>	Crest factor: 1

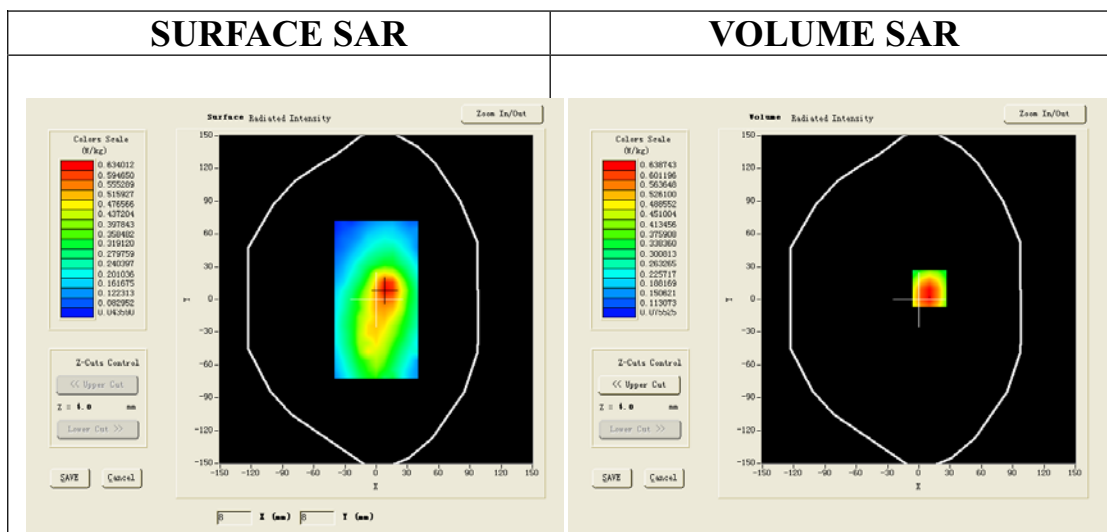

**Maximum location: X=10.00, Y=10.00**

<b>SAR 10g (W/Kg)</b>	0.428364
<b>SAR 1g (W/Kg)</b>	0.663464

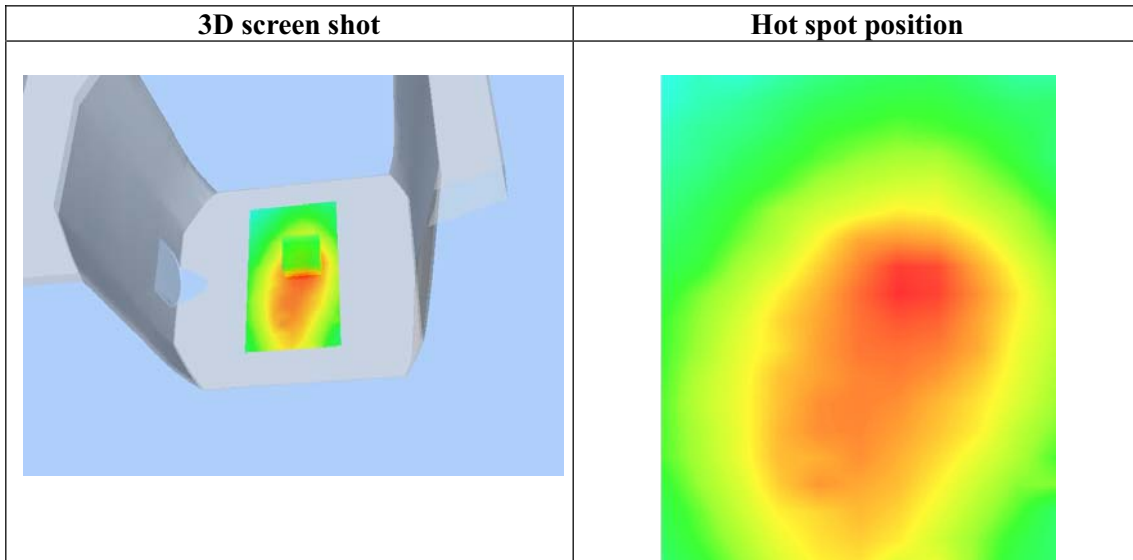
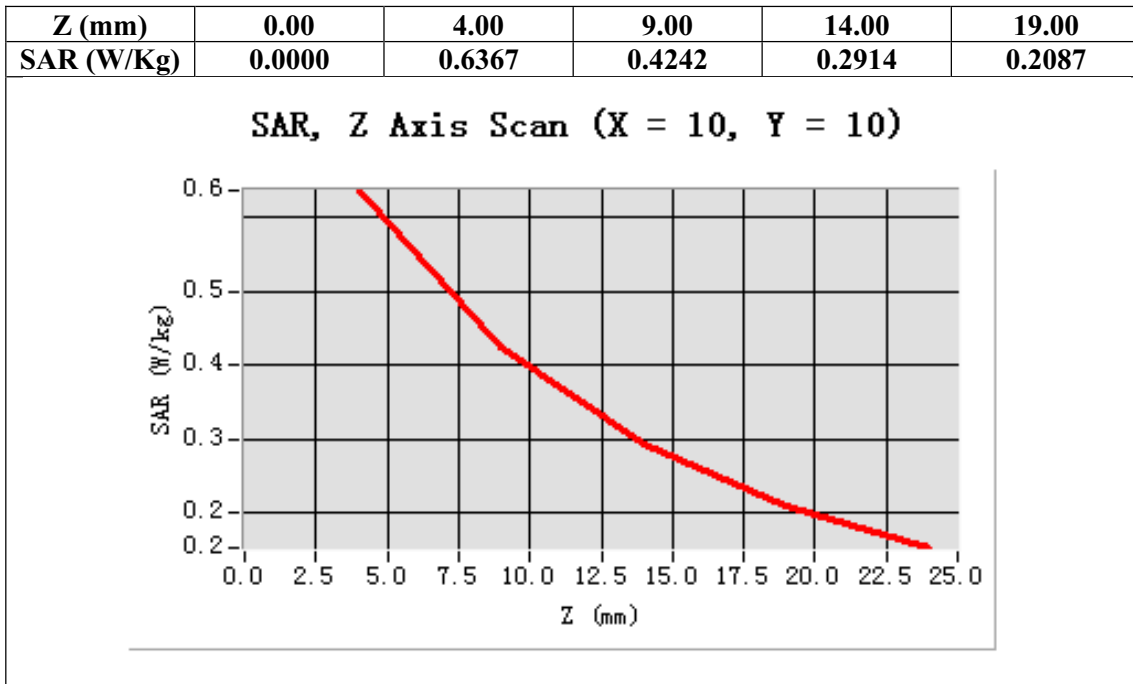

Test Laboratory: AGC Lab  
CW300High- face up 2.5cm

Test date: Mar.25, 2013

**DUT: Two-way Radio; Type: TH-UV3R**

Communication System: CW; Communication System Band: CW173.975 MHz; Duty Cycle: 1:1; Conv.F=4.58  
Frequency:173.975 MHz; Medium parameters used:  $f = 300\text{MHz}$ ;  $\sigma = 0.89\text{mho/m}$ ;  $\epsilon_r = 44.96$ ;  $\rho = 1000 \text{ kg/m}^3$  ;  
Phantom Type: Elliptical Phantom  
Ambient temperature ( $^{\circ}\text{C}$ ): 21.5, Liquid temperature( $^{\circ}\text{C}$ ): 21.0

Satimo Configuration:

Probe: EP165; Calibrated: 01/31/2013

- Sensor-Surface: 4mm (Mechanical Surface Detection)
- Phantom: Flat Phantom; Type: Elliptical Phantom
- Measurement SW: OpenSAR V4\_02\_0

**Configuration/CW 300 High/Area Scan:** Measurement grid: dx=20mm, dy=20mm

**Configuration/CW 300 High/Zoom Scan:** Measurement grid: dx=8mm,dy=8mm, dz=5mm,

<b>Area Scan</b>	ep_direct_droit2_surf8mm.txt
<b>ZoomScan</b>	5x5x7,dx=8mm dy=8mm dz=5mm,Very fast
<b>Phantom</b>	Elliptical Phantom
<b>Device Position</b>	Face up 2.5 cm separation to Phantom
<b>Band</b>	CW 173.975 MHz
<b>Channels</b>	High
<b>Signal</b>	Crest factor: 1

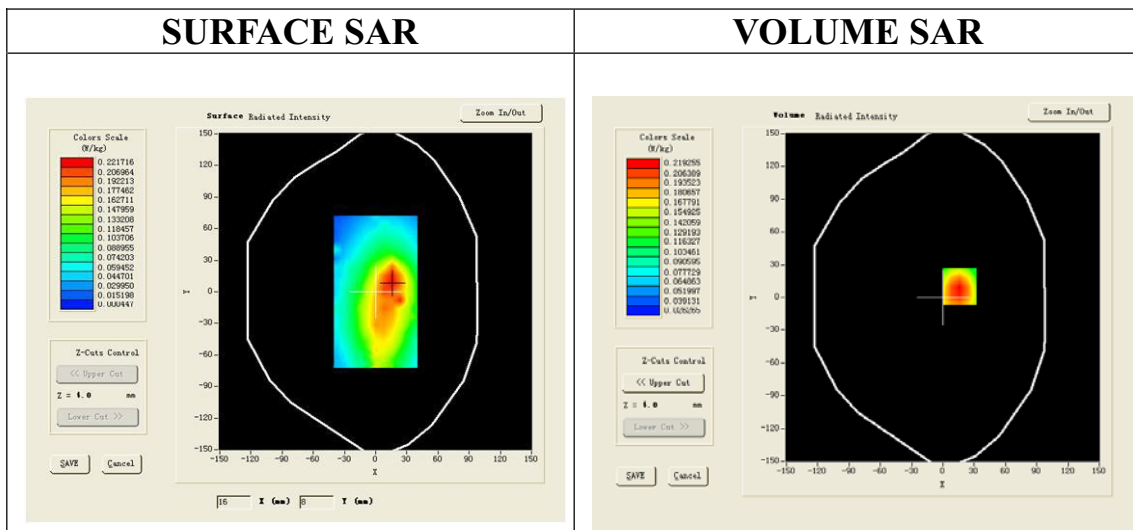

**Maximum location: X=16.00, Y=10.00**

<b>SAR 10g (W/Kg)</b>	0.146241
<b>SAR 1g (W/Kg)</b>	0.225475



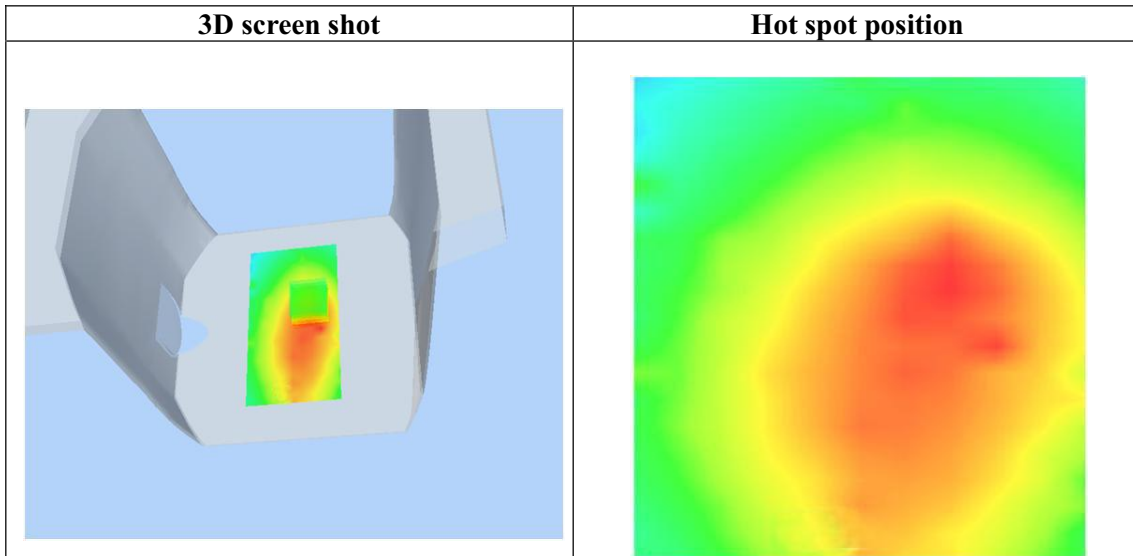
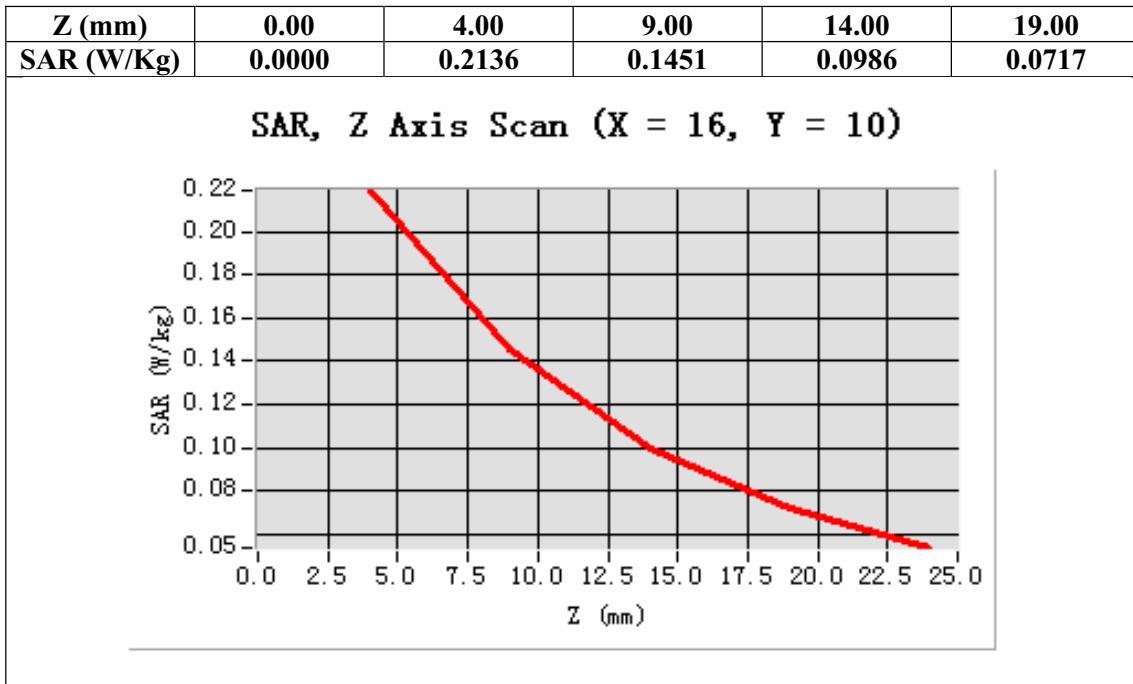

Test Laboratory: AGC Lab  
CW300Low-bottom- touch

Test date: Mar.25, 2013

**DUT: Two-way Radio; Type: TH-UV3R**

Communication System: CW; Communication System Band: CW136.025 MHz; Duty Cycle: 1:1; Conv.F=4.58  
Frequency:136.025 MHz; Medium parameters used:  $f = 300\text{MHz}$ ;  $\sigma = 0.91\text{mho/m}$ ;  $\epsilon_r = 57.72$ ;  
 $\rho = 1000 \text{ kg/m}^3$  ; Phantom Type: Elliptical Phantom  
Ambient temperature ( $^{\circ}\text{C}$ ): 21.5, Liquid temperature( $^{\circ}\text{C}$ ): 21.0

Satimo Configuration:

Probe: EP165; Calibrated: 01/31/2013

- Sensor-Surface: 4mm (Mechanical Surface Detection)
- Phantom: Flat Phantom; Type: Elliptical Phantom
- Measurement SW: OpenSAR V4\_02\_0

**Configuration/CW 300 Low/Area Scan:** Measurement grid: dx=20mm, dy=20mm

**Configuration/CW 300 Low/Zoom Scan:** Measurement grid: dx=8mm,dy=8mm, dz=5mm,

<b>Area Scan</b>	ep_direct_droit2_surf8mm.txt
<b>ZoomScan</b>	5x5x7,dx=8mm dy=8mm dz=5mm,Very fast
<b>Phantom</b>	Elliptical Phantom
<b>Device Position</b>	Back close to Phantom with Accessories
<b>Band</b>	CW 136.025 MHz
<b>Channels</b>	Low
<b>Signal</b>	Crest factor: 1

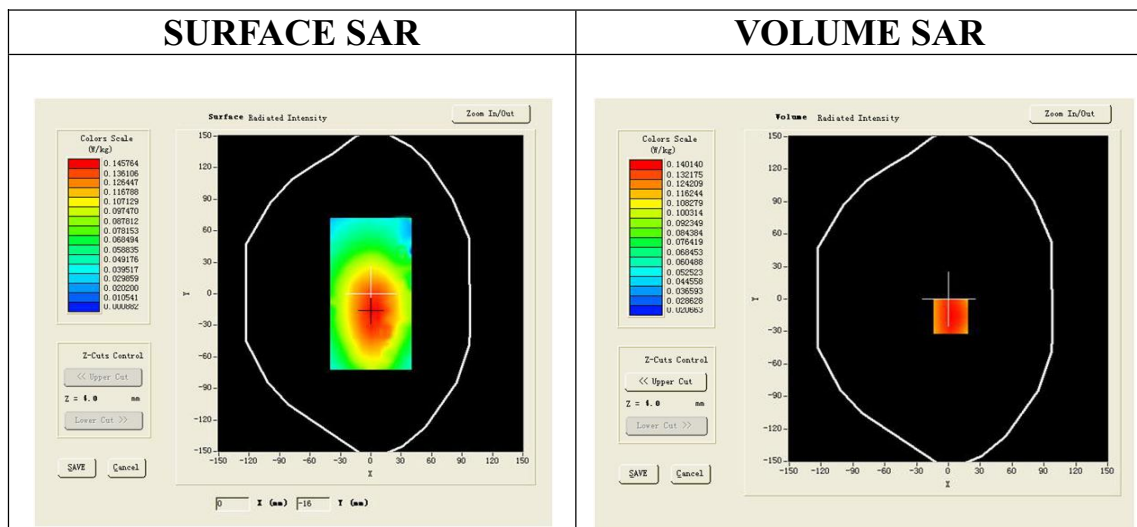

**Maximum location: X=2.00, Y=-16.00**

<b>SAR 10g (W/Kg)</b>	0.101245
<b>SAR 1g (W/Kg)</b>	0.142364

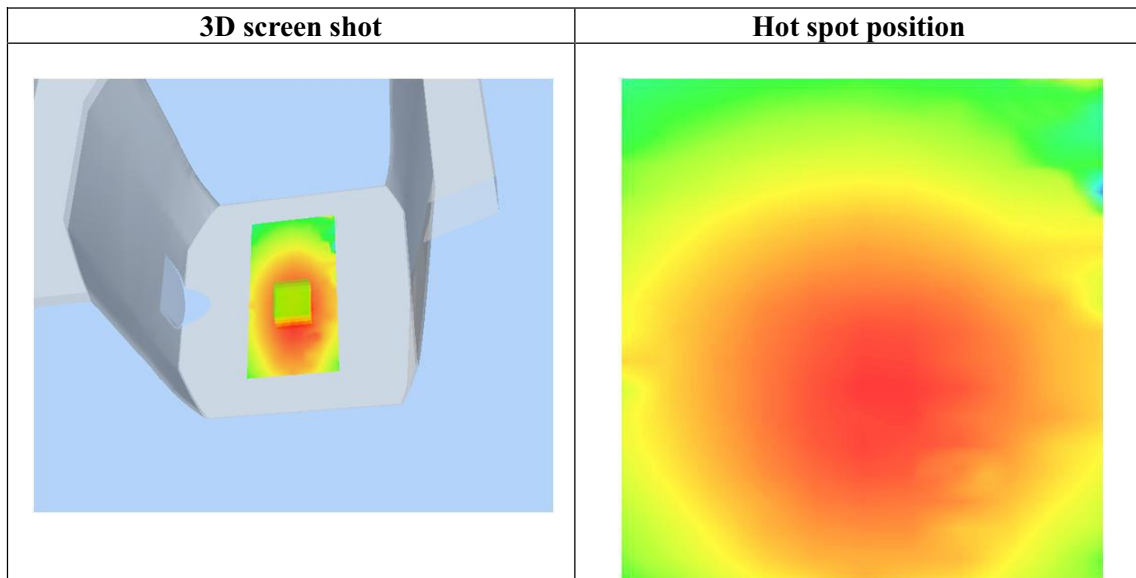
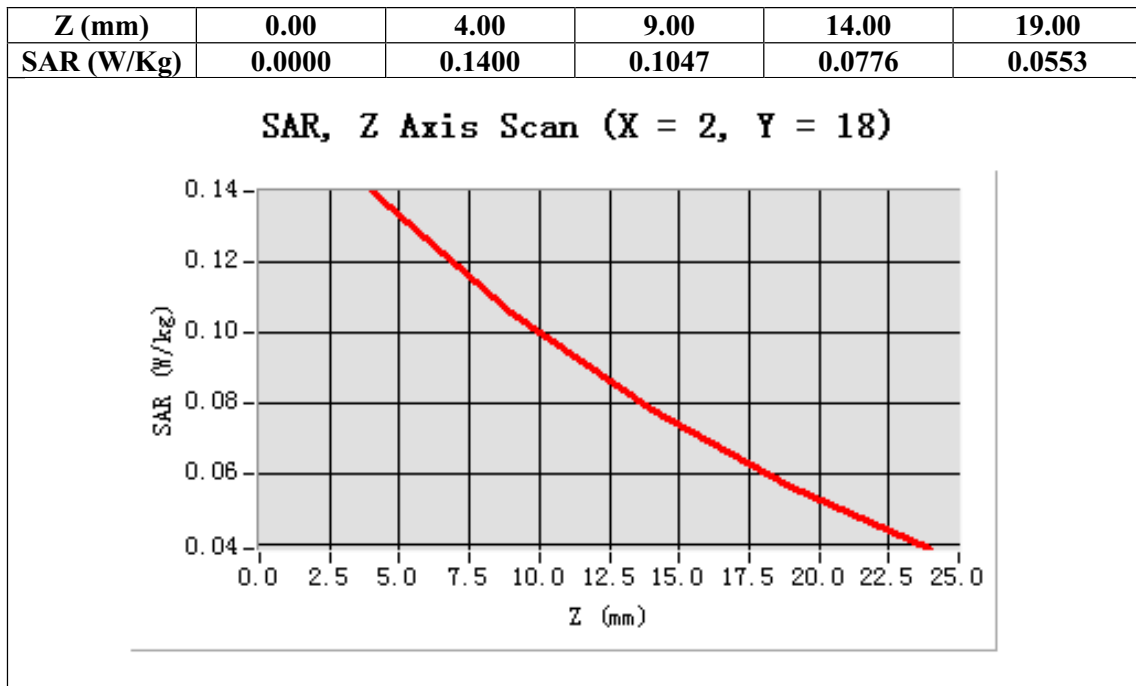

Test Laboratory: AGC Lab  
CW300Middle- bottom -touch

Test date: Mar.25, 2013

**DUT: Two-way Radio; Type: TH-UV3R**

Communication System: CW; Communication System Band: CW155.000 MHz; Duty Cycle: 1:1; Conv.F=4.58  
Frequency: 155.000 MHz; Medium parameters used:  $f = 300\text{MHz}$ ;  $\sigma = 0.91\text{mho/m}$ ;  $\epsilon_r = 57.72$ ;  
 $\rho = 1000 \text{ kg/m}^3$  ; Phantom Type: Elliptical Phantom  
Ambient temperature ( $^{\circ}\text{C}$ ): 21.5, Liquid temperature( $^{\circ}\text{C}$ ): 21.0

Satimo Configuration:

Probe: EP165; Calibrated: 01/31/2013

- Sensor-Surface: 4mm (Mechanical Surface Detection)
- Phantom: Flat Phantom; Type: Elliptical Phantom
- Measurement SW: OpenSAR V4\_02\_0

**Configuration/CW 300 Mid/Area Scan (6x8x1):** Measurement grid: dx=20mm, dy=20mm

**Configuration/CW 300 Mid/Zoom Scan (5x5x7)/Cube 0:** Measurement grid: dx=8mm,dy=8mm, dz=5mm;

<b>Area Scan</b>	ep_direct_droit2_surf8mm.txt
<b>ZoomScan</b>	5x5x7,dx=8mm dy=8mm dz=5mm,Very fast
<b>Phantom</b>	Elliptical Phantom
<b>Device Position</b>	Back close to Phantom with Accessories
<b>Band</b>	CW 155.000 MHz
<b>Channels</b>	Middle
<b>Signal</b>	Crest factor: 1

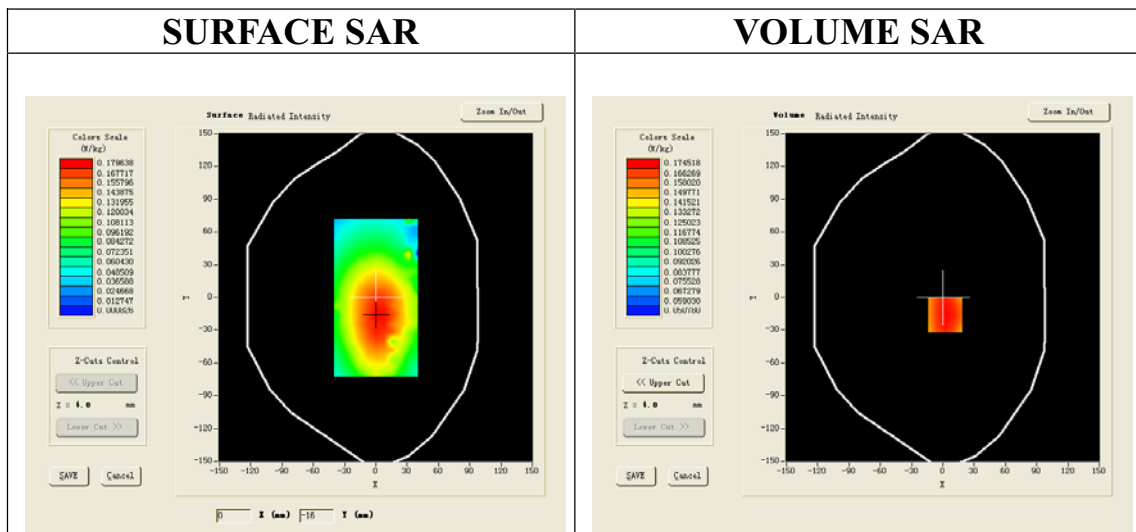

**Maximum location: X=2.00, Y=-16.00**

<b>SAR 10g (W/Kg)</b>	0.123642
<b>SAR 1g (W/Kg)</b>	0.166245

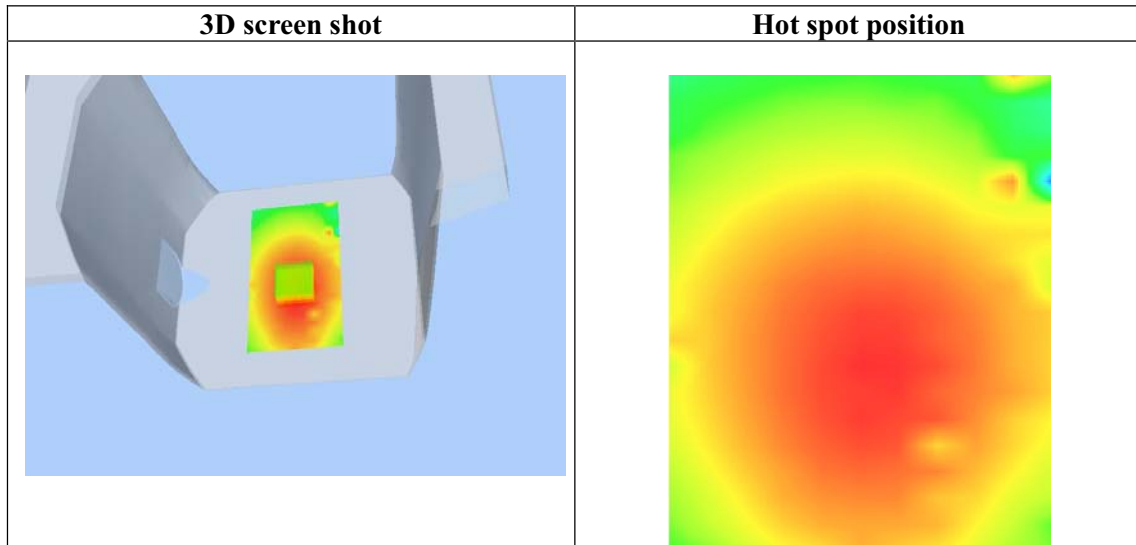
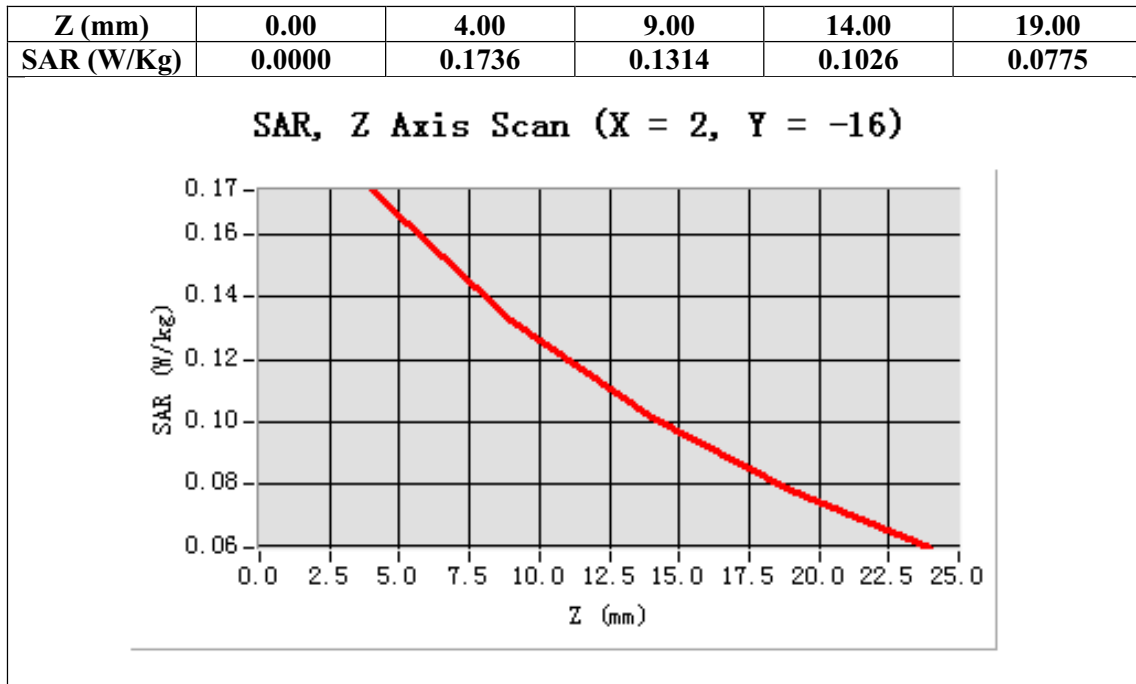

Test Laboratory: AGC Lab  
CW300High- bottom -touch

Test date: Mar.25, 2013

**DUT: Two-way Radio; Type: TH-UV3R**

Communication System: CW; Communication System Band: CW 173.975 MHz; Duty Cycle: 1:1; Conv.F=4.58  
Frequency: 173.975 MHz; Medium parameters used:  $f = 300\text{MHz}$ ;  $\sigma = 0.91\text{mho/m}$ ;  $\epsilon_r = 57.72$ ;  
 $\rho = 1000 \text{ kg/m}^3$  ; Phantom Type: Elliptical Phantom  
Ambient temperature ( $^{\circ}\text{C}$ ): 21.5, Liquid temperature( $^{\circ}\text{C}$ ): 21.0

Satimo Configuration:

Probe: EP165; Calibrated: 01/31/2013

- Sensor-Surface: 4mm (Mechanical Surface Detection)
- Phantom: Flat Phantom; Type: Elliptical Phantom
- Measurement SW: OpenSAR V4\_02\_0

**Configuration/CW 300 High/Area Scan (6x8x1):** Measurement grid: dx=20mm, dy=20mm

**Configuration/CW 300 High/Zoom Scan (5x5x7)/Cube 0:** Measurement grid: dx=8mm,dy=8mm, dz=5mm;

<b>Area Scan</b>	ep_direct_droit2_surf8mm.txt
<b>ZoomScan</b>	5x5x7,dx=8mm dy=8mm dz=5mm,Very fast
<b>Phantom</b>	Elliptical Phantom
<b>Device Position</b>	Back close to Phantom with Accessories
<b>Band</b>	CW 173.975MHz
<b>Channels</b>	Top
<b>Signal</b>	Crest factor: 1

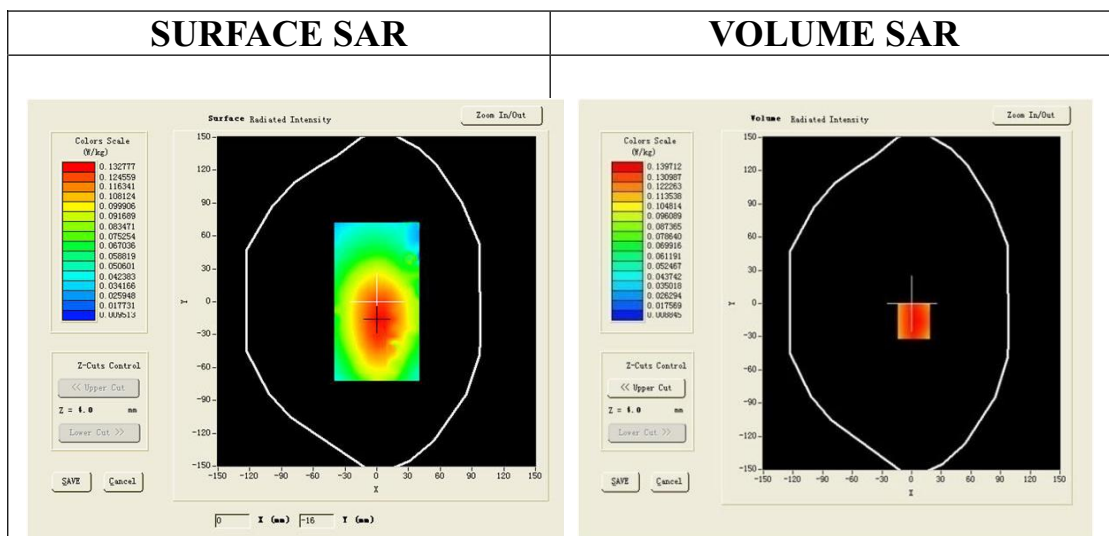

**Maximum location: X=2.00, Y=-16.00**

<b>SAR 10g (W/Kg)</b>	0.075364
<b>SAR 1g (W/Kg)</b>	0.131233

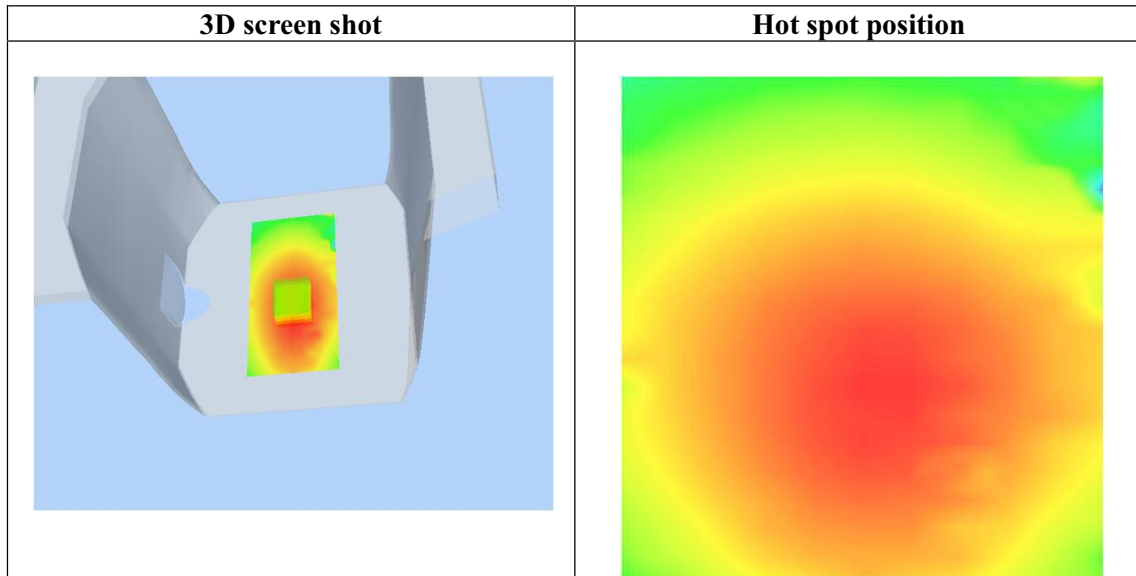
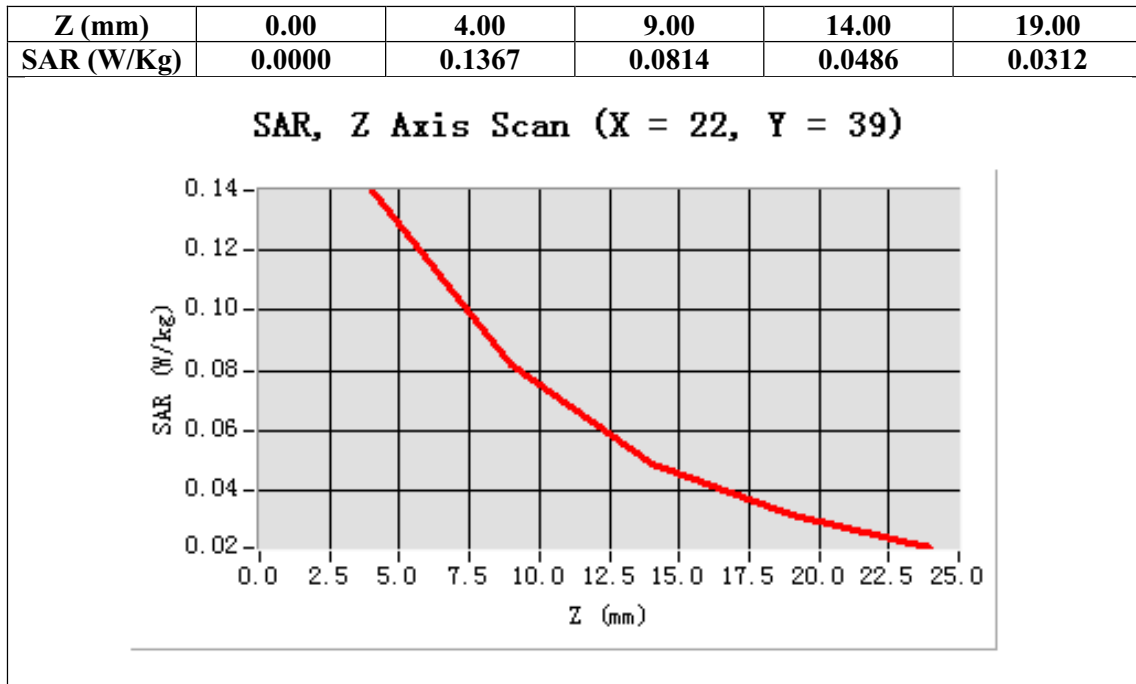

Test Laboratory: AGC Lab

Test date: Mar.25, 2013

CW450 Low- Face up 2.5 cm separation

**DUT: Two-way Radio; Type: TH-UV3R**

Communication System: CW; Communication System Band: CW 407.625 MHz; Duty Cycle: 1:1; Conv.F=4.75

Frequency: 407.625 MHz; Medium parameters used:  $f = 450$  MHz;  $\sigma = 0.91$  mho/m;  $\epsilon_r = 43.56$ ;

$\rho = 1000$  kg/m<sup>3</sup> ; Phantom Type: Elliptical Phantom

Ambient temperature (°C): 21.5, Liquid temperature (°C): 21.0

Satimo Configuration:

Probe: EP165; Calibrated: 01/31/2013

- Sensor-Surface: 4mm (Mechanical Surface Detection)
- Phantom: Flat Phantom; Type: Elliptical Phantom
- Measurement SW: OpenSAR V4\_02\_0

**Configuration/CW 450 for low head/Area Scan (6x8x1):** Measurement grid: dx=20mm, dy=20mm

**Configuration/CW 450 for low head/Zoom Scan (5x5x7)/Cube 0:** Measurement grid: dx=8mm, dy=8mm, dz=5mm,

<b>Area Scan</b>	ep_direct_droit2_surf8mm.txt
<b>ZoomScan</b>	5x5x7,dx=8mm dy=8mm dz=5mm,Very fast
<b>Phantom</b>	Elliptical Phantom
<b>Device Position</b>	Face up 2.5 cm separation to Phantom
<b>Band</b>	CW 407.625
<b>Channels</b>	Low
<b>Signal</b>	Crest factor: 1

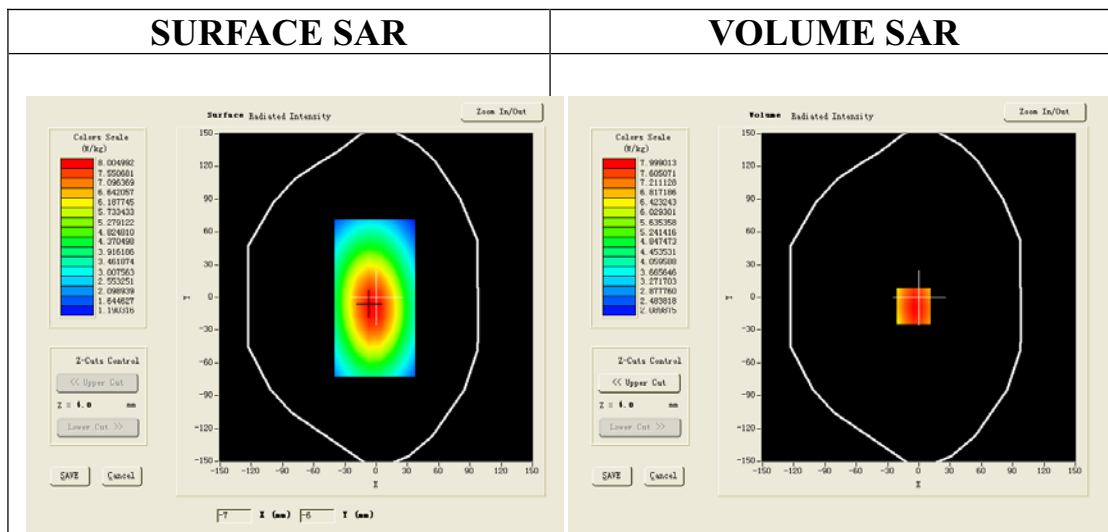

**Maximum location: X=-5.00, Y=-8.00**

<b>SAR 10g (W/Kg)</b>	5.669533
<b>SAR 1g (W/Kg)</b>	7.722454



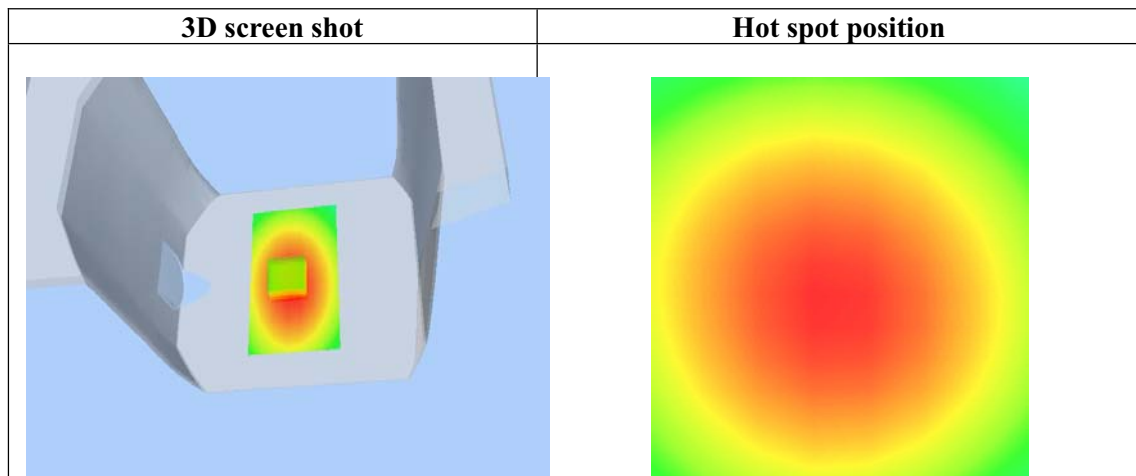
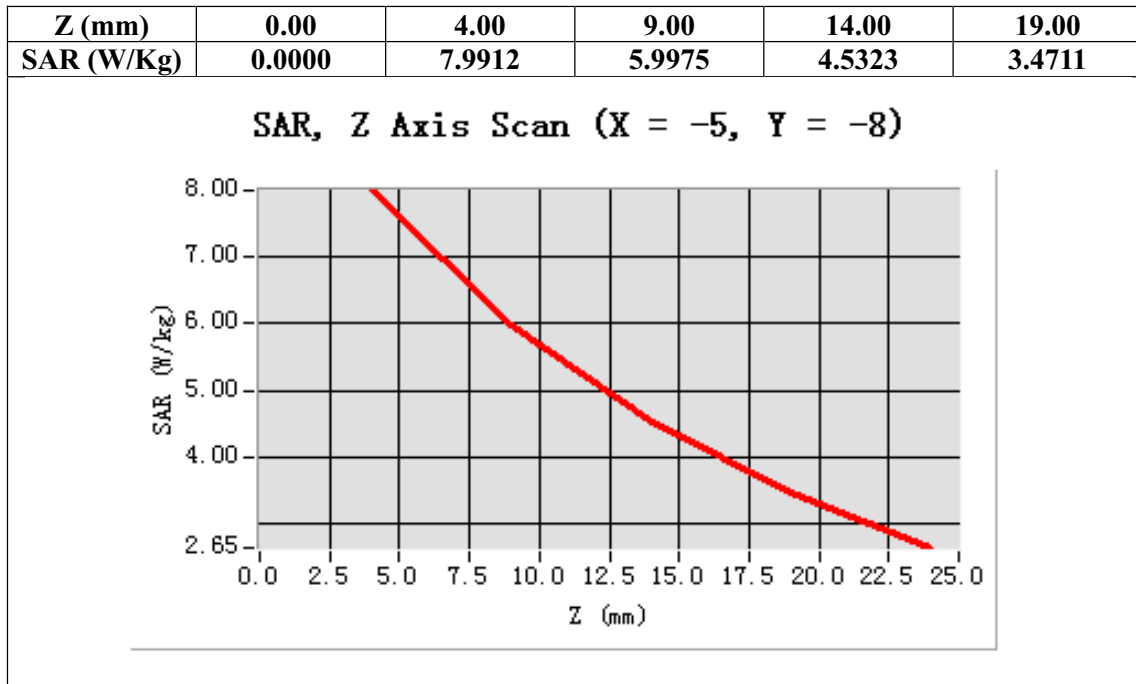

Test Laboratory: AGC Lab

Test date: Mar.25, 2013

CW450 Middle- Face up 2.5 cm separation

DUT: Two-way Radio; Type: TH-UV3R

Communication System: CW; Communication System Band: CW 435.325 MHz; Duty Cycle: 1:1; Conv.F=4.75  
Frequency: 435.325 MHz; Medium parameters used:  $f = 450$  MHz;  $\sigma = 0.91$  mho/m;  $\epsilon_r = 43.56$ ;  $\rho = 1000$  kg/m<sup>3</sup> ;  
Phantom Type: Elliptical Phantom  
Ambient temperature (°C): 21.5, Liquid temperature (°C): 21.0

Satimo Configuration:

Probe: EP165; Calibrated: 01/31/2013

- Sensor-Surface: 4mm (Mechanical Surface Detection)
- Phantom: Flat Phantom; Type: Elliptical Phantom
- Measurement SW: OpenSAR V4\_02\_0

Configuration/CW 450 for Mid head/Area Scan (6x8x1): Measurement grid: dx=20mm, dy=20mm

Configuration/CW 450 for Mid head/Zoom Scan (5x5x7)/Cube 0: Measurement grid: dx=8mm, dy=8mm, dz=5mm;

Area Scan	ep_direct_droit2_surf8mm.txt
ZoomScan	5x5x7,dx=8mm dy=8mm dz=5mm,Very fast
Phantom	Elliptical Phantom
Device Position	Face up 2.5 cm separation to Phantom
Band	CW 435.325
Channels	Middle
Signal	Crest factor: 1

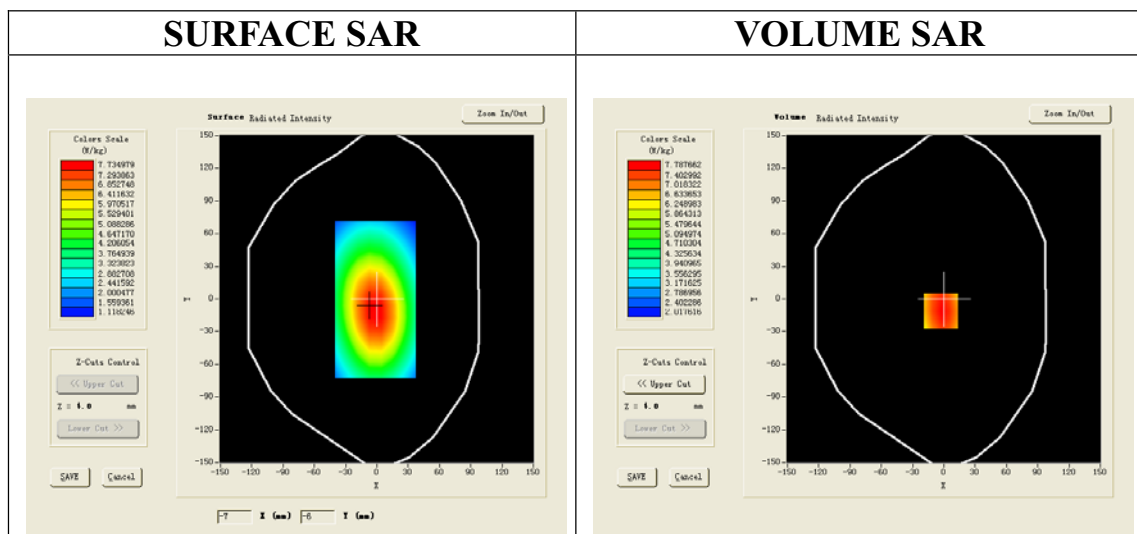

Maximum location: X=-3.00, Y=-11.00

SAR 10g (W/Kg)	5.499775
SAR 1g (W/Kg)	7.515432

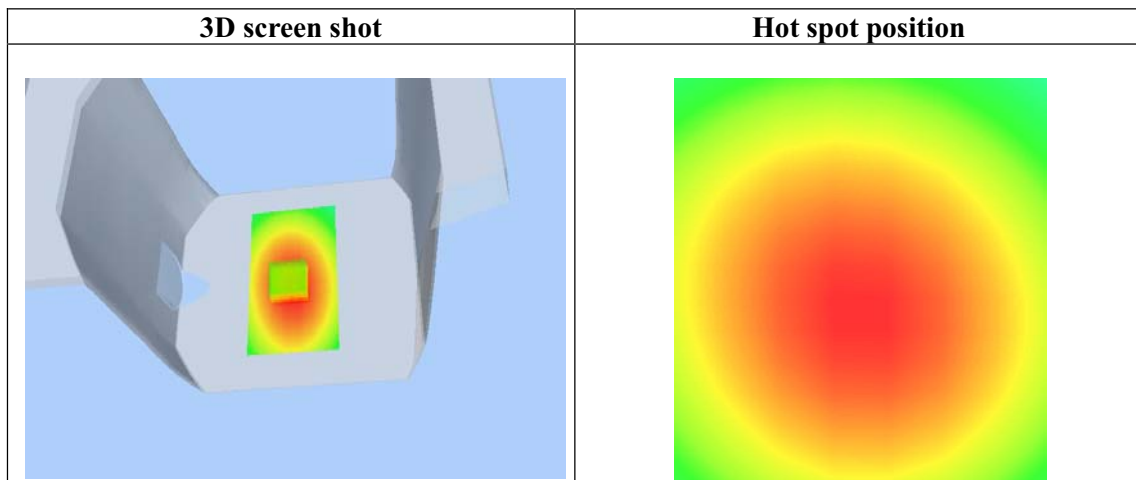
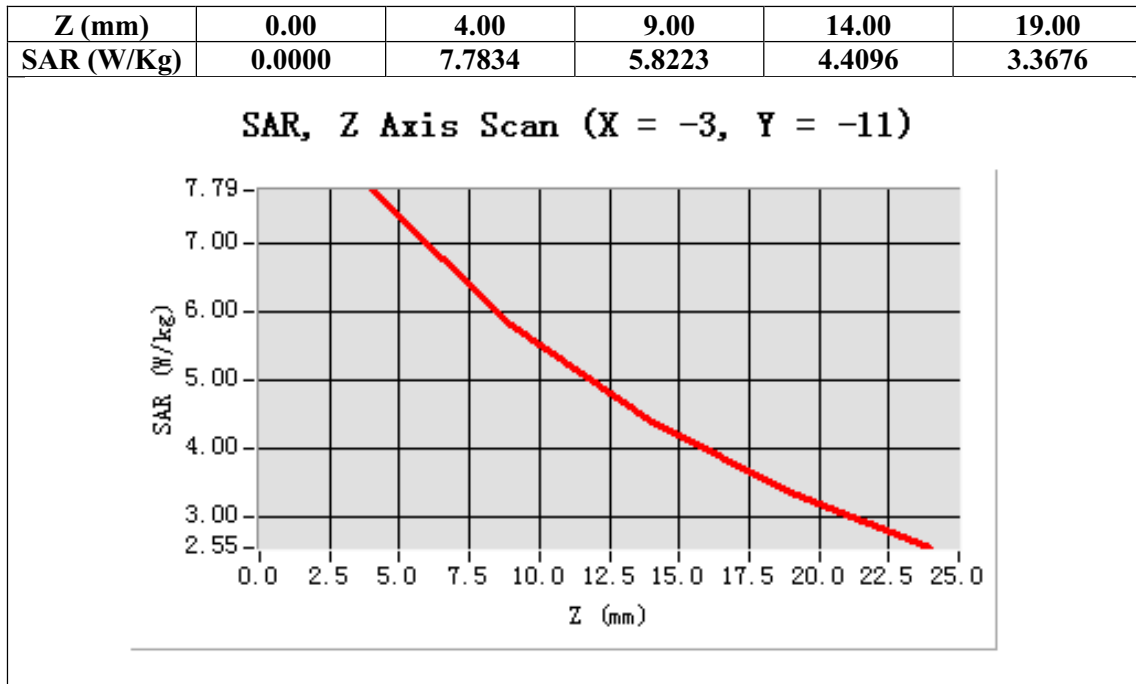

**Test Laboratory: AGC Lab**  
**CW450 High- Face up 2.5 cm separation**  
**DUT: Two-way Radio; Type: TH-UV3R**

**Test date: Mar.25, 2013**

Communication System: CW; Communication System Band: CW 469.975 MHz; Duty Cycle: 1:1; Conv.F=4.75  
Frequency: 469.975 MHz; Medium parameters used:  $f = 450$  MHz;  $\sigma = 0.91$  mho/m;  $\epsilon_r = 43.56$ ;  $\rho = 1000$  kg/m<sup>3</sup> ;  
Phantom Type: Elliptical Phantom  
Ambient temperature (°C): 21.5, Liquid temperature (°C): 21.0

Satimo Configuration:

Probe: EP165; Calibrated: 01/31/2013

- Sensor-Surface: 4mm (Mechanical Surface Detection)
- Phantom: Flat Phantom; Type: Elliptical Phantom
- Measurement SW: OpenSAR V4\_02\_0

**Configuration/CW 450 for Mid head/Area Scan (6x8x1):** Measurement grid: dx=20mm, dy=20mm

**Configuration/CW 450 for Mid head/Zoom Scan (5x5x7)/Cube 0:** Measurement grid: dx=8mm, dy=8mm, dz=5mm;

<b>Area Scan</b>	ep_direct_droit2_surf8mm.txt
<b>ZoomScan</b>	5x5x7,dx=8mm dy=8mm dz=5mm,Very fast
<b>Phantom</b>	Elliptical Phantom
<b>Device Position</b>	Face up 2.5 cm separation to Phantom
<b>Band</b>	CW 469.975
<b>Channels</b>	High
<b>Signal</b>	Crest factor: 1

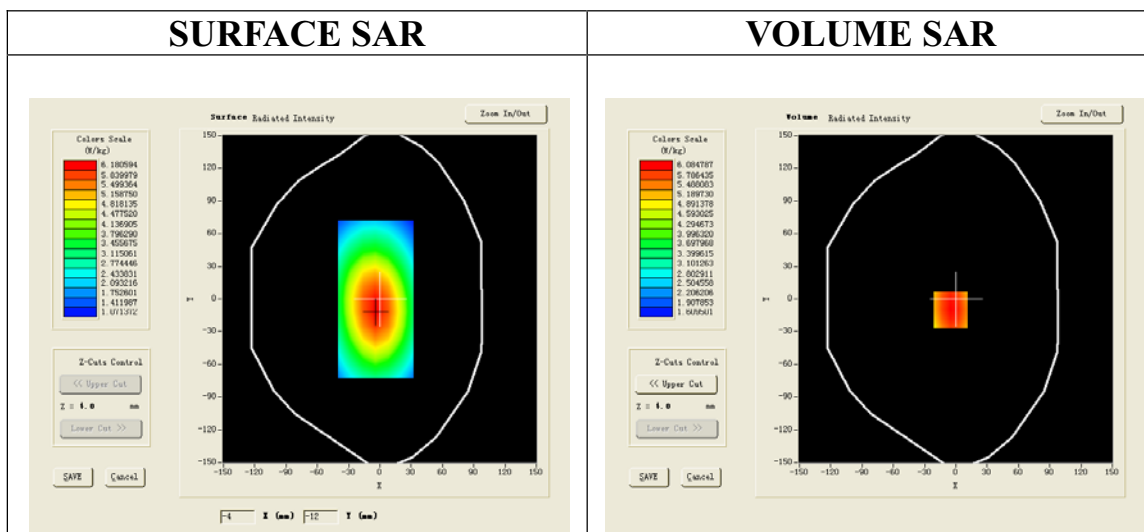

**Maximum location: X=-5.00, Y=-10.00**

<b>SAR 10g (W/Kg)</b>	4.319855
<b>SAR 1g (W/Kg)</b>	5.871344

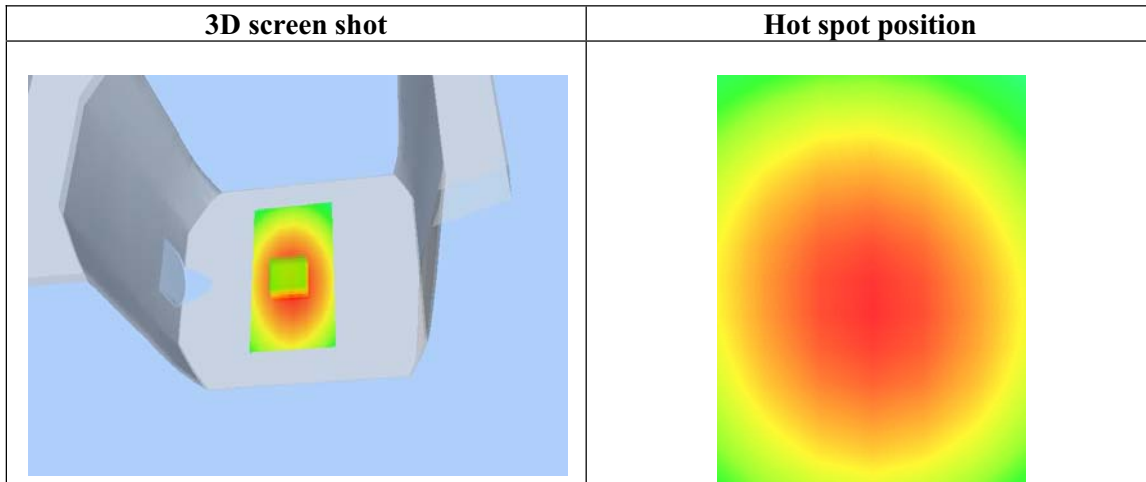
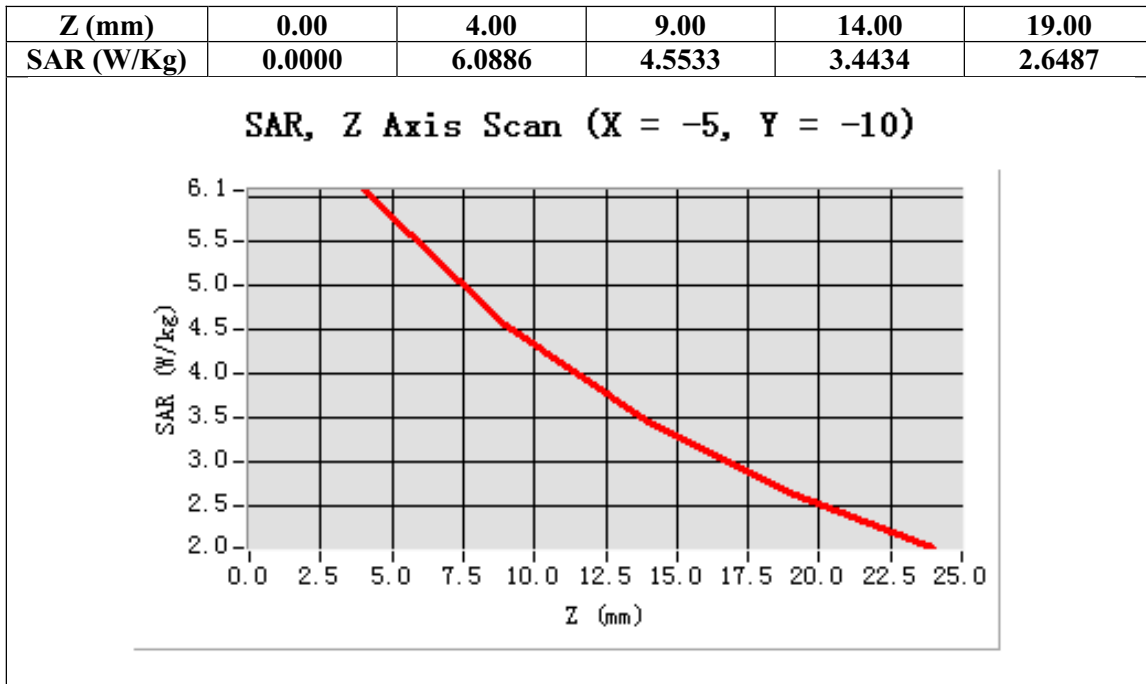

**Test Laboratory: AGC Lab**  
**CW450 Low-Body-touch**

**Test date: Mar.25, 2013**

**DUT: Two-way Radio; Type: TH-UV3R**

Communication System: CW; Communication System Band: CW 407.625MHz; Duty Cycle: 1:1; Conv.F=4.75  
Frequency: 407.625 MHz; Medium parameters used:  $f = 450$  MHz;  $\sigma = 0.96$  mho/m;  $\epsilon_r = 56.82$ ;  $\rho = 1000$  kg/m<sup>3</sup> ;  
Phantom Type: Elliptical Phantom  
Ambient temperature (°C): 21.5, Liquid temperature(°C): 21.0

Satimo Configuration:

Probe: EP165; Calibrated: 01/31/2013

- Sensor-Surface: 4mm (Mechanical Surface Detection)
- Phantom: Flat Phantom; Type: Elliptical Phantom
- Measurement SW: OpenSAR V4\_02\_0

**Configuration/CW 450 for low touch/Area Scan:** Measurement grid: dx=20mm, dy=20mm

**Configuration/CW 450 for low touch/Zoom Scan:** Measurement grid: dx=8mm,dy=8mm, dz=5mm,

<b>Area Scan</b>	ep_direct_droit2_surf8mm.txt
<b>ZoomScan</b>	5x5x7,dx=8mm dy=8mm dz=5mm,Very fast
<b>Phantom</b>	Elliptical Phantom
<b>Device Position</b>	Back close to Phantom with Accessories
<b>Band</b>	CW 407.625
<b>Channels</b>	Low
<b>Signal</b>	Crest factor: 1

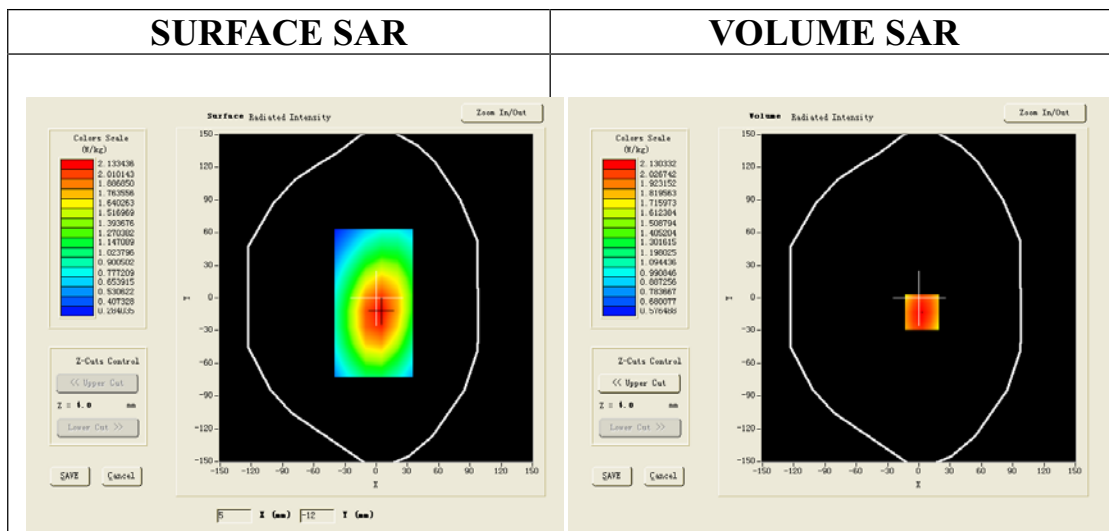

**Maximum location: X=3.00, Y=-13.00**

<b>SAR 10g (W/Kg)</b>	1.519865
<b>SAR 1g (W/Kg)</b>	2.050432

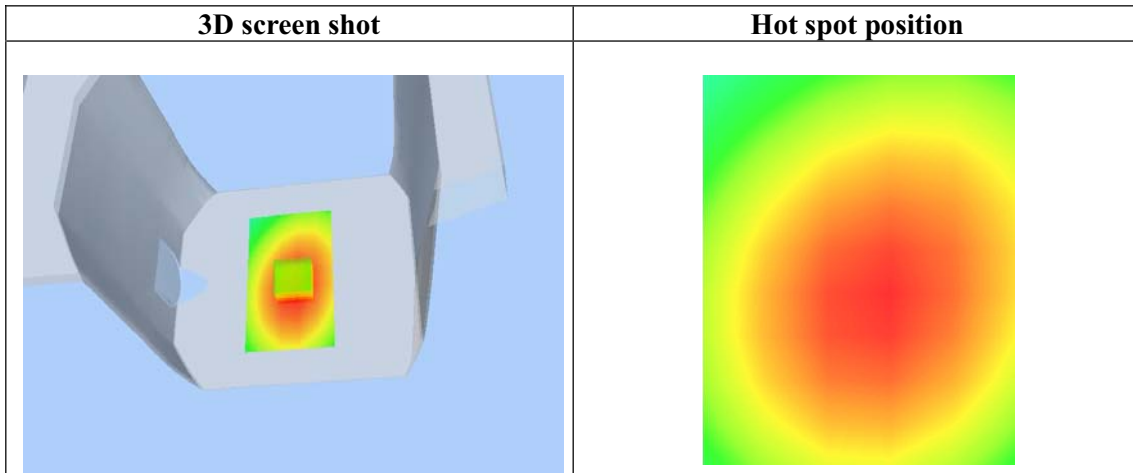
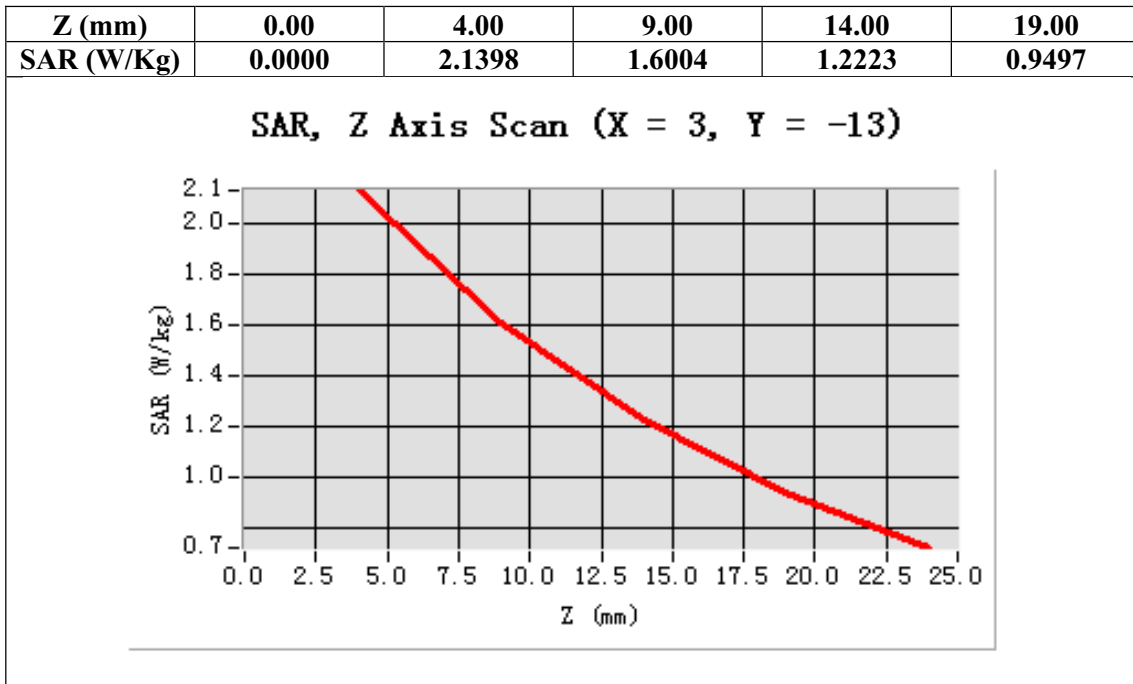

**Test Laboratory: AGC Lab**  
**CW450 Middle -Body -touch**  
**DUT: Two-way Radio; Type: TH-UV3R**

**Test date: Mar.25, 2013**

Communication System: CW; Communication System Band: CW 435.325 MHz; Duty Cycle: 1:1; Conv.F=4.75  
Frequency: 435.325 MHz; Medium parameters used:  $f = 450$  MHz;  $\sigma = 0.96$  mho/m;  $\epsilon_r = 56.82$ ;  $\rho = 1000$  kg/m<sup>3</sup> ;  
Phantom Type: Elliptical Phantom  
Ambient temperature (°C): 21.5, Liquid temperature(°C): 21.0

Satimo Configuration:

Probe: EP165; Calibrated: 01/31/2013

- Sensor-Surface: 4mm (Mechanical Surface Detection)
- Phantom: Flat Phantom; Type: Elliptical Phantom
- Measurement SW: OpenSAR V4\_02\_0

**Configuration/CW 450 for Mid touch/Area Scan:** Measurement grid: dx=20mm, dy=20mm

**Configuration/CW 450 for Mid touch/Zoom Scan:** Measurement grid: dx=8mm,dy=8mm, dz=5mm,

<b>Area Scan</b>	ep_direct_droit2_surf8mm.txt
<b>ZoomScan</b>	5x5x7,dx=8mm dy=8mm dz=5mm,Very fast
<b>Phantom</b>	Elliptical Phantom
<b>Device Position</b>	Back close to Phantom with Accessories
<b>Band</b>	CW 435.325
<b>Channels</b>	Middle
<b>Signal</b>	Crest factor: 1

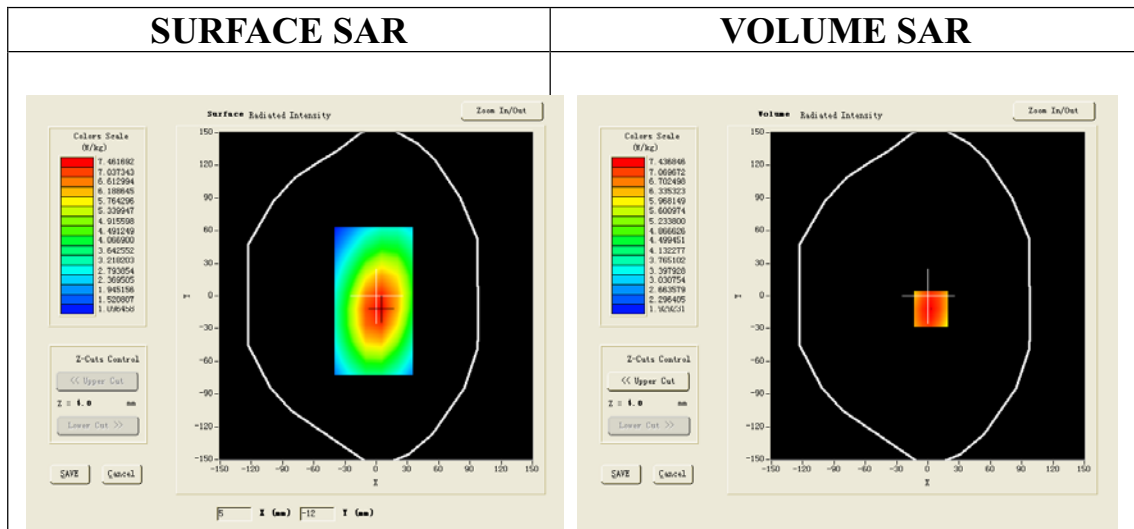

**Maximum location: X=3.00, Y=-12.00**

<b>SAR 10g (W/Kg)</b>	5.252345
<b>SAR 1g (W/Kg)</b>	7.188954



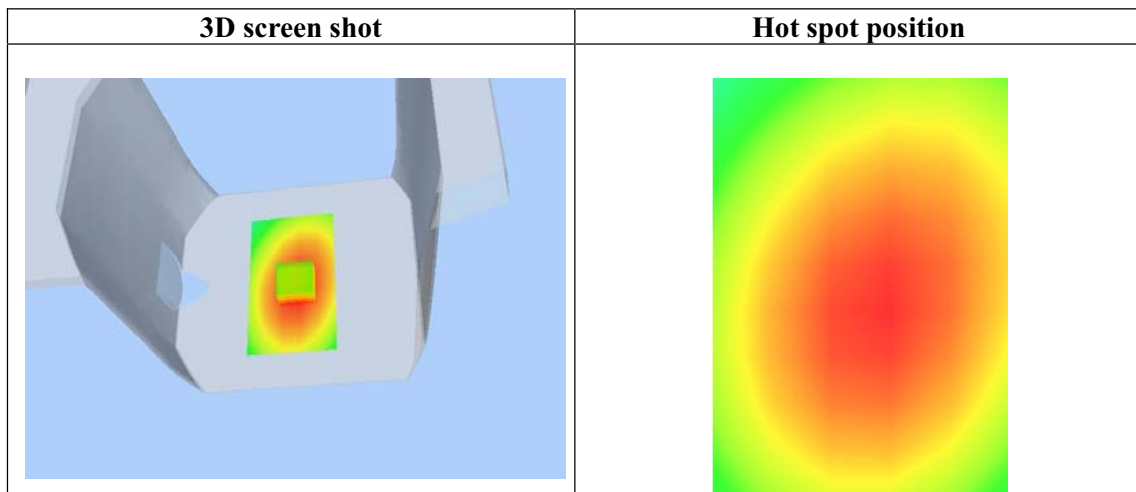
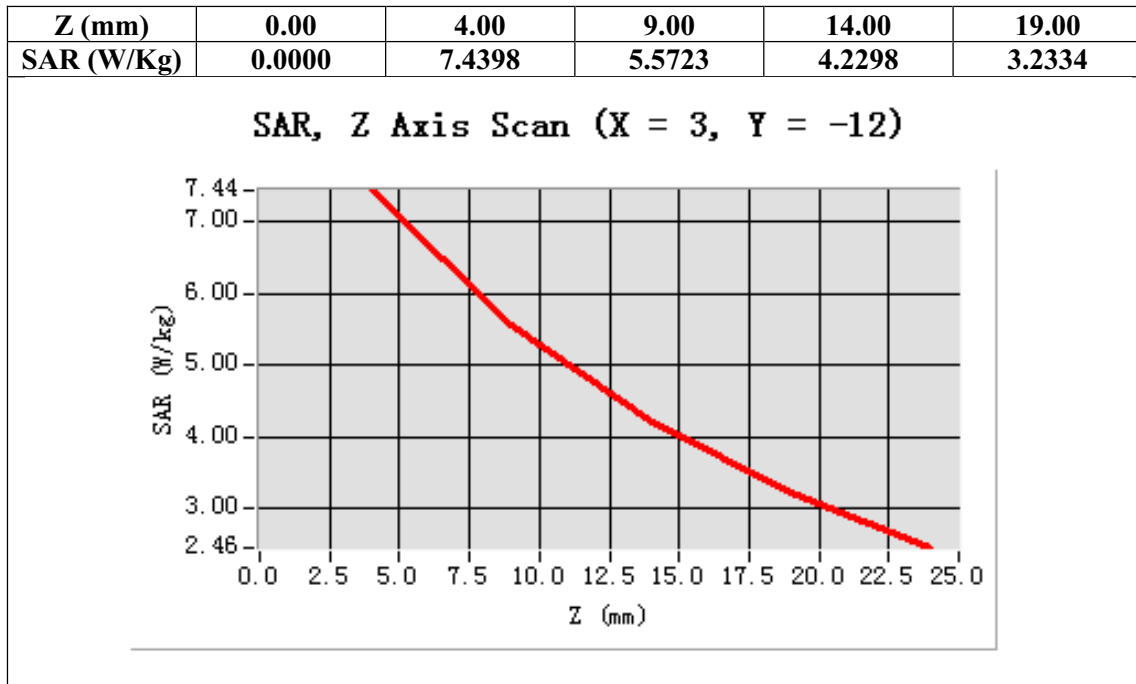

**Test Laboratory: AGC Lab**  
**CW450 High -body -touch**

**Test date: Mar.25, 2013**

**DUT: Two-way Radio; Type: TH-UV3R**

Communication System: CW; Communication System Band: CW 469.975 MHz; Duty Cycle: 1:1; Conv.F=4.75  
Frequency: 469.975 MHz; Medium parameters used:  $f = 450$  MHz;  $\sigma = 0.96$  mho/m;  $\epsilon_r = 56.82$ ;  $\rho = 1000$  kg/m<sup>3</sup> ;  
Phantom Type: Elliptical Phantom  
Ambient temperature (°C): 21.5, Liquid temperature(°C): 21.0

Satimo Configuration:

Probe: EP165; Calibrated: 01/31/2013

- Sensor-Surface: 4mm (Mechanical Surface Detection)
- Phantom: Flat Phantom; Type: Elliptical Phantom
- Measurement SW: OpenSAR V4\_02\_0

**Configuration/CW 450 for high touch/Area Scan (6x8x1):** Measurement grid: dx=20mm, dy=20mm  
**Configuration/CW 450 for high touch/Zoom Scan (5x5x7)/Cube 0:** Measurement grid: dx=8mm, dy=8mm, dz=5mm;

<b>Area Scan</b>	ep_direct_droit2_surf8mm.txt
<b>ZoomScan</b>	5x5x7,dx=8mm dy=8mm dz=5mm,Very fast
<b>Phantom</b>	Elliptical Phantom
<b>Device Position</b>	Back close to Phantom with Accessories
<b>Band</b>	CW 469.975
<b>Channels</b>	High
<b>Signal</b>	Crest factor: 1

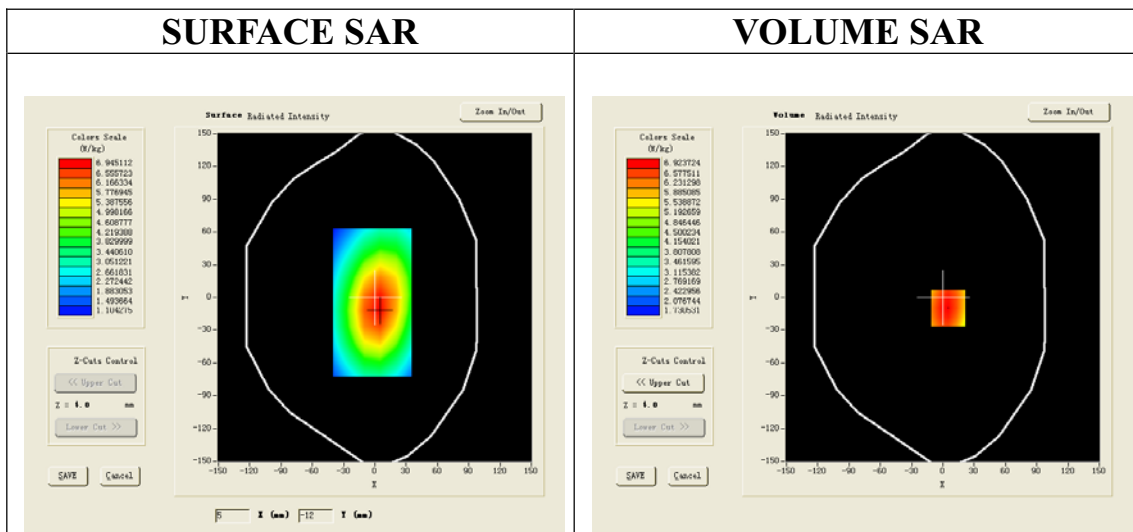

**Maximum location: X=5.00, Y=-10.00**

<b>SAR 10g (W/Kg)</b>	4.899875
<b>SAR 1g (W/Kg)</b>	6.692563

