

Appendix 5.

Schematics

DATE	REVISION NUMBER	INITIALS	DESCRIPTION
2010/06/13	WU5108-X1	CASH	Initial release.
2010/06/28	WU5108-X2	CASH	For Antenna match (TOKO Only) L7 4.3nH change to 3.3nH C24 2.0nH change to 1.5nH L8 4.3nH change to 3.9nH
2010/06/28	WU5108-D1	CASH	For TX/RX EVM C8 8.2pF change to 10pF C12 8.2pF change to 10pF L1 2.0nH change to 1.8nH L2 2.0nH change to 1.8nH For RX Sensitivity C19 4.7pF change to 10pF C20 4.7pF change to 10pF C23 1.5pF change to 1.0pF

WU5108 1T1R 802.11b/g/n USB WLAN

 AboCom Systems, Inc			
Title: WU5108 802.11b/g/n USB WLAN			
Size: B	Document Number: 1.Cover	Rev: D10	
Date: Monday, April 18, 2011	Sheet: 1	of: 4	

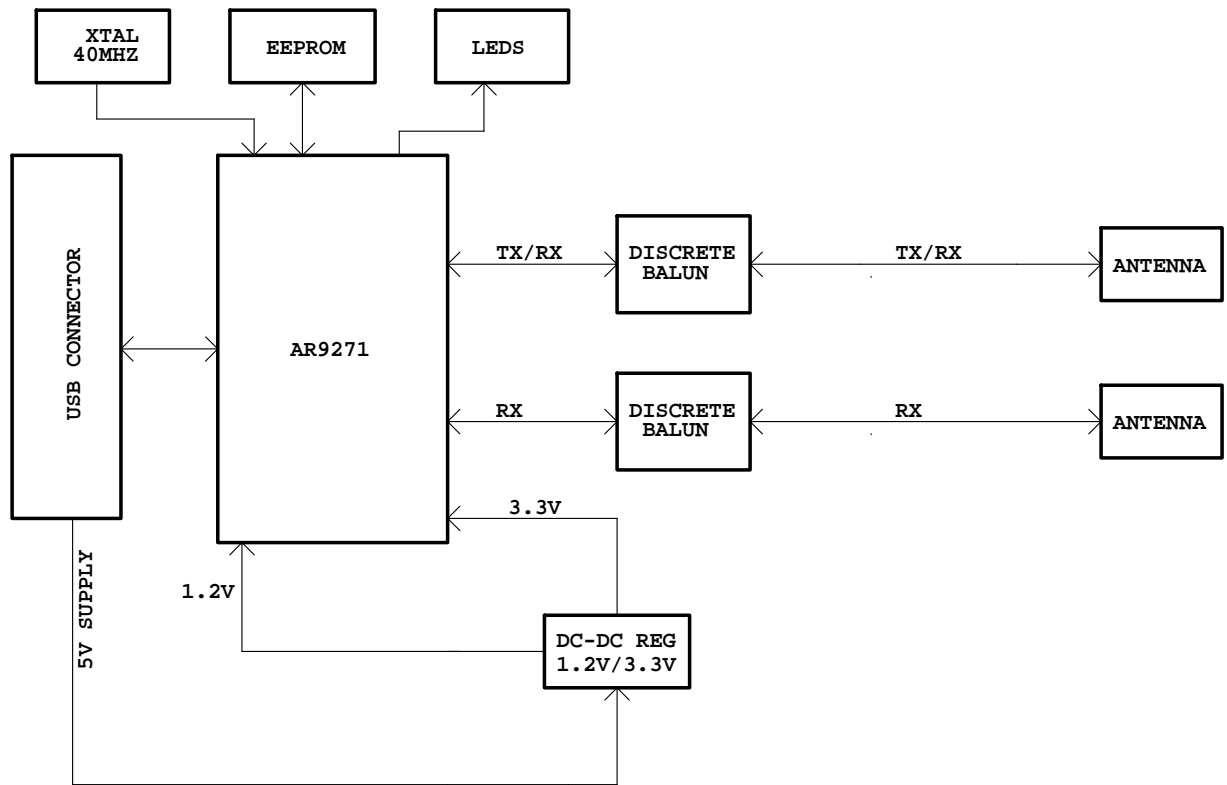

 AboCom Systems, Inc		
WU5108 802.11b/g/n USB WLAN		
Title	Document Number	Rev
Size B	2.Block Diagram	D10
Date: Monday, April 18, 2011	Sheet 2 of 4	

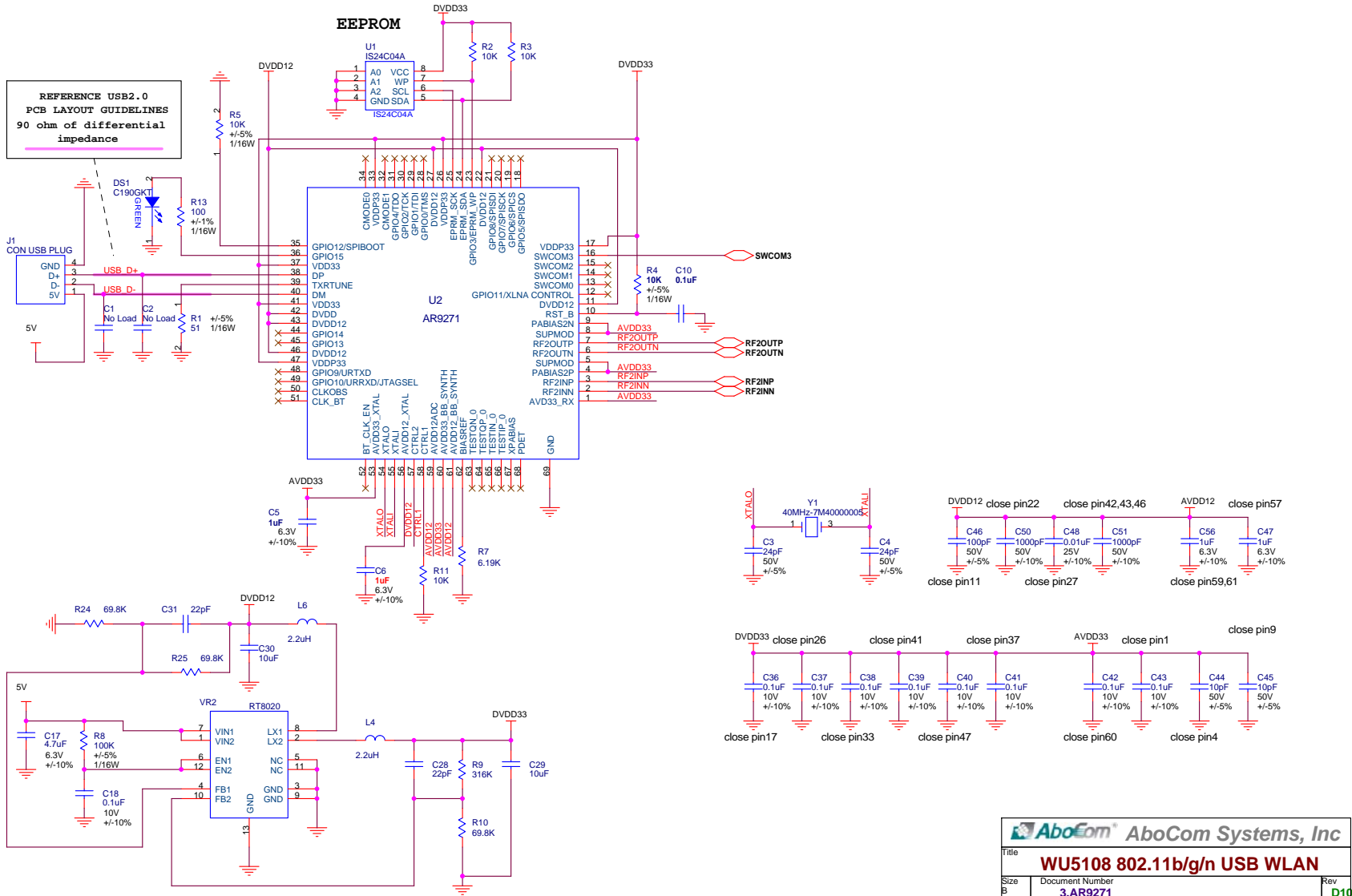

TX/RX

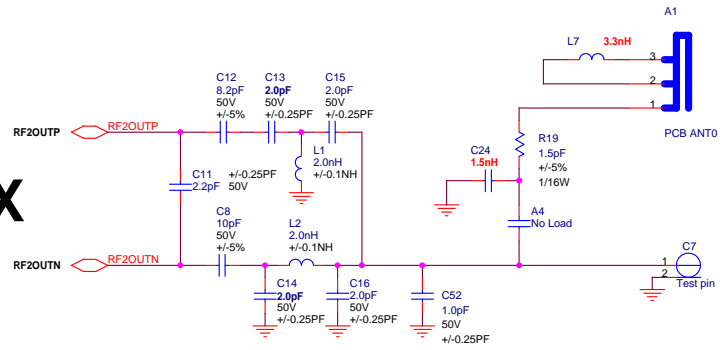

RX

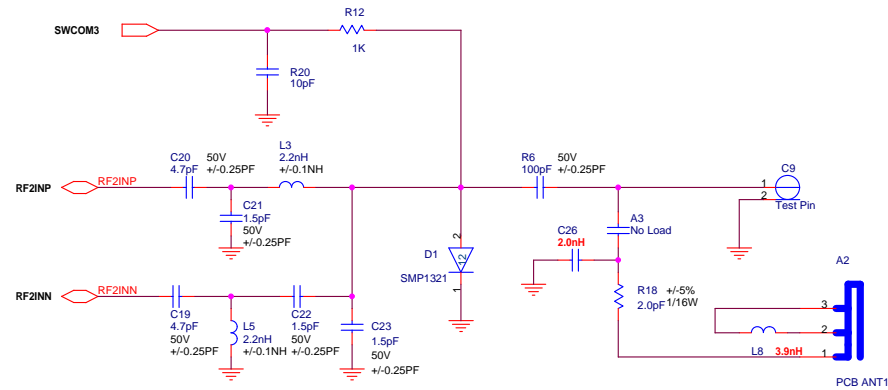

AboCom Systems, Inc		
Title WU5108 802.11b/g/n USB WLAN		
Size B	Document Number 4.RF	Rev D10
Date: Monday, April 18, 2011 Sheet 4 of 4		