

Nice

CE 0682

UK
CA EAC
made in Italy

MYGOBD MYGOBD/A

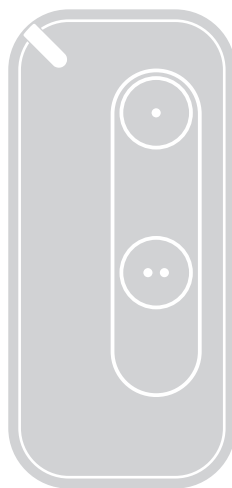

MYGO2BD
MYGO2BD/A

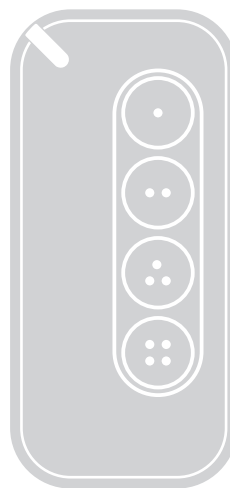

MYGO4BD
MYGO4BD/A

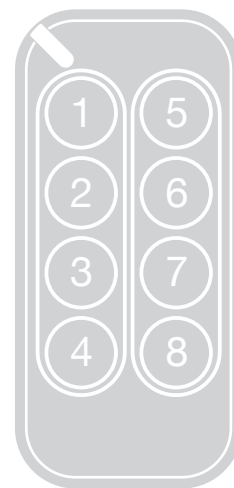

MYGO8BD
MYGO8BD/A

Two-way transmitters

EN - Instructions and warnings for installation and use

Nice

CONTENTS

1	GENERAL SAFETY WARNINGS AND PRECAUTIONS	2
2	PRODUCT DESCRIPTION AND INTENDED USE	3
2.1	List of constituent parts	3
2.2	Transmitter functions	3
3	MEMORISING THE TRANSMITTER	4
3.1	Transmitter verification	4
3.2	Memorising the transmitter	4
3.2.1	Memorisation in "Mode 1"	4
3.2.2	Memorisation in "Mode 2"	4
3.2.3	Memorisation in "Extended Mode 2"	4
3.2.4	Memorisation through the "ENABLING Code" (between an OLD transmitter already memorised and a NEW transmitter)	4
4	STATUS REQUEST PROCEDURE	5
5	ENCODING SWITCH PROCEDURE	5
6	DELETION PROCEDURE	5
7	REPLACING THE BATTERY	5
8	PRODUCT DISPOSAL	6
8.1	Battery disposal	6
9	TECHNICAL SPECIFICATIONS	6
10	CONFORMITY	6
10.1	SIMPLIFIED EU DECLARATION OF CONFORMITY	6
10.2	COMPLIANCE WITH THE FCC RULES (PART 15) AND WITH RSS-210 RULES	6
11	ACCESSORIES	7
11.1	String for keyring	7
11.2	FASTENING SUPPORT	7



CAUTION! – This manual contains important instructions and warnings for personal safety. Carefully read all parts of this manual. If in doubt, suspend installation immediately and contact the Nice Technical Assistance.



CAUTION! – Important instructions: keep this manual in a safe place to enable future product maintenance and disposal procedures.

- The product packing materials must be disposed of in compliance with local regulations.
- Never apply modifications to any part of the device. Operations other than those specified may only cause malfunctions. The manufacturer declines all liability for damage caused by makeshift modifications to the product.
- Never place the device near to sources of heat and never expose to naked flames. These actions may damage the product and cause malfunctions.
- This product is not intended for use by people (including children) with reduced physical, sensory or mental capabilities or who lack experience and knowledge, unless they have been given supervision or instruction concerning the use of the product by a person responsible for their safety.
- Make sure that children do not play with the product.
- Handle the product with care, being sure not to crush, knock or drop it in order to avoid damage.
- The batteries must be removed from the appliance prior to its disposal.
- The batteries must be disposed of in a safe way.
- The manufacturer of this appliance, Nice S.p.A., hereby declares that the product complies with Directive 2014/53/EU.
- The instruction manual and the full text of the EU Declaration of Conformity are available at the following Internet address: www.niceforyou.com, under the "support" and "download" sections.
- For transmitters: 433 MHz: ERP < 10 dBm.

2 PRODUCT DESCRIPTION AND INTENDED USE

Transmitters of the series **MYGOBD (MYGOBD/A)** are designed to control automations (gates, garage doors, road barriers and similar).



CAUTION! – Any use other than that specified herein or in environmental conditions other than those stated in this manual is to be considered improper and is strictly forbidden!

2.1 LIST OF CONSTITUENT PARTS

“**Figure 1**” shows the main parts making up **MYGOBD (MYGOBD/A)** transmitters.

The range consists of three models:

- **MYGO2BD (MYGO2BD/A)** with two buttons
- **MYGO4BD (MYGO4BD/A)** with four buttons
- **MYGO8BD (MYGO8BD/A)** with eight buttons.

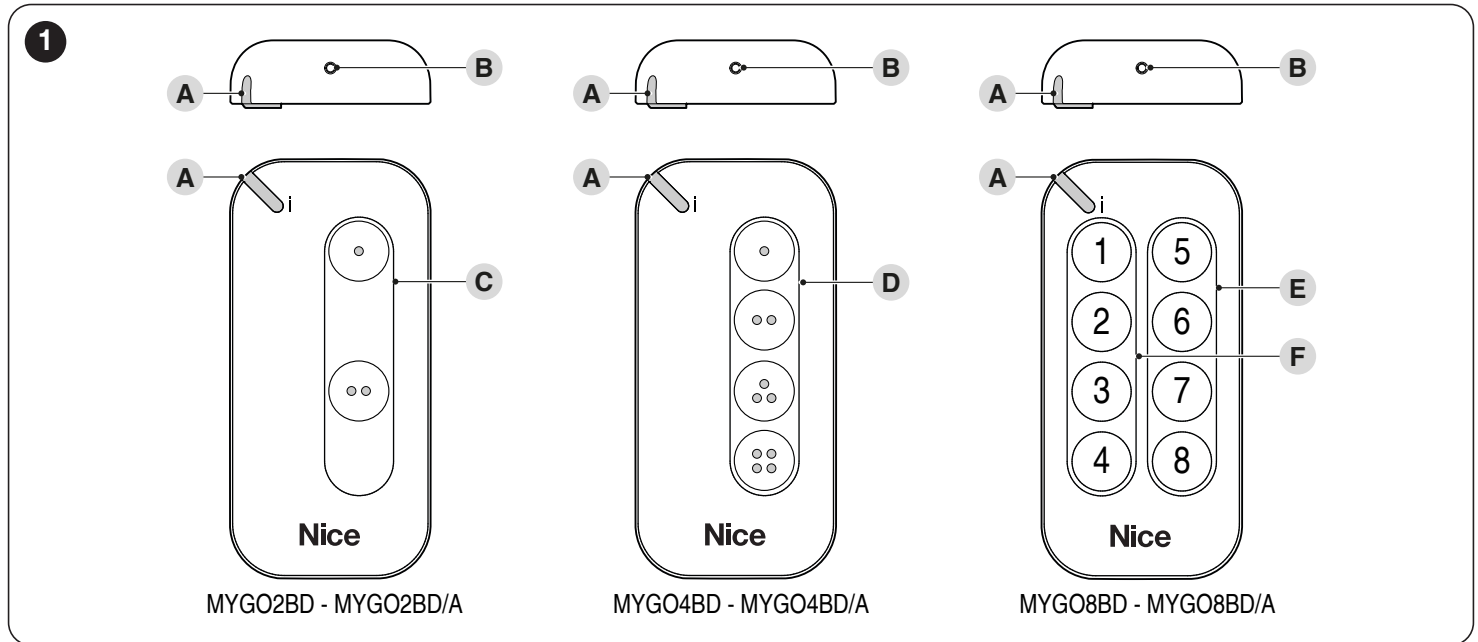

- A** Two-colour signalling LED and automation status request button
B Hole for unlocking and removing the rear shell
C Control buttons area for models **MYGO2BD (MYGO2BD/A)**
D Control buttons area for models **MYGO4BD (MYGO4BD/A)**
E-F Control buttons area for models **MYGO8BD (MYGO8BD/A)**

2.2 TRANSMITTER FUNCTIONS

MYGOBD (MYGOBD/A) are compatible with receivers that adopt the “O-Code” (“O-Code/A”) one-way radio encoding system or the “BD” two-way encoding system. The latter system offers the exclusive advanced functions of the “NiceOpera” system, besides additional functions, such as:

- the sending of the confirmation, from the receiver to the transmitter, that the transmitted command was received. After the transmission, **if the command was received**, the transmitter vibrates and the green LED lights up for 2 seconds. In case of “**command NOT received**”, the transmitter LED, after a series of orange flashes, remains lit red for 2 seconds.
- the sending of the automation’s status (for example, whether the gate is open or closed): refer to the paragraph “**STATUS REQUEST PROCEDURE**” on page 5).
- indication of the automation’s anomaly status: flashing of the red LED and intermittent vibration.

The **MYGOBD (MYGOBD/A)** transmitters, configured in two-way mode, can be memorised on maximum 10 two-way receivers [OXIBD (OXIBD/A)]. If they are configured in one-way mode, they can be memorised on any desired number of one-way receivers.

For the encoding switch procedure, refer to the paragraph “**ENCODING SWITCH PROCEDURE**” on page 5.



Each single encoding allows for exploiting only the functions linked to that specific encoding system.

With the memorisation of two-way transmitters in the OXIBD (OXIBD/A) receiver, the identification code of the same receiver is automatically memorised by the transmitter.



WARNING! – If the two-way transmitter in the OXIBD (OXIBD/A) receiver is deleted, to complete the operation it is necessary to also delete the transmitter’s memory. To perform this procedure, refer to the paragraph “**DELETION PROCEDURE**” on page 5.

MYGOBD (MYGOBD/A) transmitters can be programmed with the ProView device (**Figure 2**).

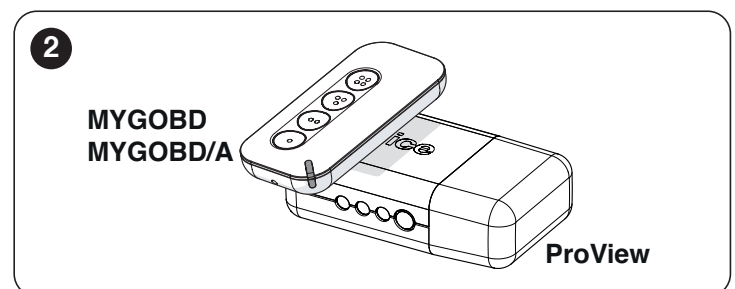

3 MEMORISING THE TRANSMITTER

3.1 TRANSMITTER VERIFICATION

Before memorising the transmitter in the automation's receiver, ensure that it is working correctly by pressing any button while observing whether LED (A) lights up.

If LED (A) fails to light up, check the condition of the battery and replace it if necessary (refer to the "REPLACING THE BATTERY" paragraph on page 5).

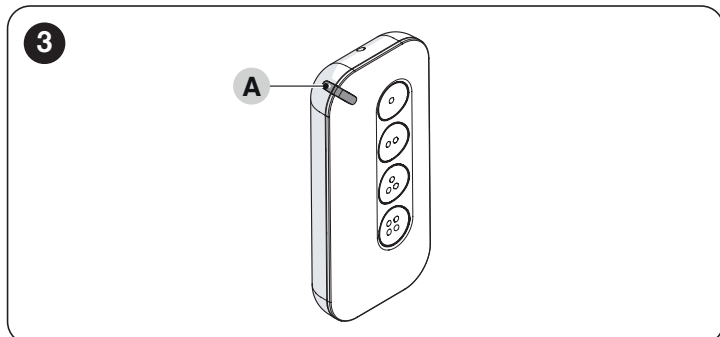

3.2 MEMORISING THE TRANSMITTER

To memorise the transmitter in a receiver, the following procedures can be adopted:

- memorisation in "Mode 1"
- memorisation in "Mode 2"
- memorisation in "Extended Mode 2"
- memorisation through the "Enabling Code" received from a previously memorised transmitter.

 These procedures are described in the instruction manual of the receiver or control unit with which the transmitter must be operated. The above-mentioned manuals are also available on the website: www.niceforyou.com.

3.2.1 MEMORISATION IN "MODE 1"

This mode allows for memorising in the receiver, once only, all the transmitter command buttons, associating them **automatically** with each command managed from the control unit (default commands).

 Refer to the control unit instructions to identify the type of command that will be paired with each transmitter button.

3.2.2 MEMORISATION IN "MODE 2"

Allows for memorising in the receiver a single transmitter button, associating it with the commands managed from the control unit (maximum 4, chosen by the user).

 The same procedure must be repeated for each button to be memorised.

3.2.3 MEMORISATION IN "EXTENDED MODE 2"

This procedure is the same as the memorisation in "Mode 2", with the added possibility of choosing the desired command (to be paired with the button being memorised) in an **extended** list of commands managed from the control unit (up to 15 different commands).

 Refer to the control unit instructions to identify the extended list of commands.

3.2.4 MEMORISATION THROUGH THE "ENABLING CODE" (BETWEEN AN OLD TRANSMITTER ALREADY MEMORISED AND A NEW TRANSMITTER)

The **MYGOBD (MYGOBD/A)** transmitter has a secret code, the so-called "ENABLING CODE". By transferring this code from a memorised transmitter to a new transmitter, the latter is recognised (and memorised) automatically by the receiver.

To perform the memorisation procedure:

1. Draw the two transmitters, NEW and OLD, near to one another, as shown in "Figure 4".

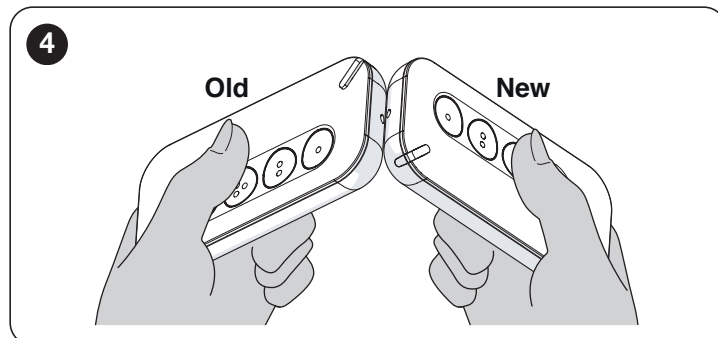

2. Press and release any command button on the NEW transmitter. LED (A) of the OLD transmitter will switch on and start flashing.

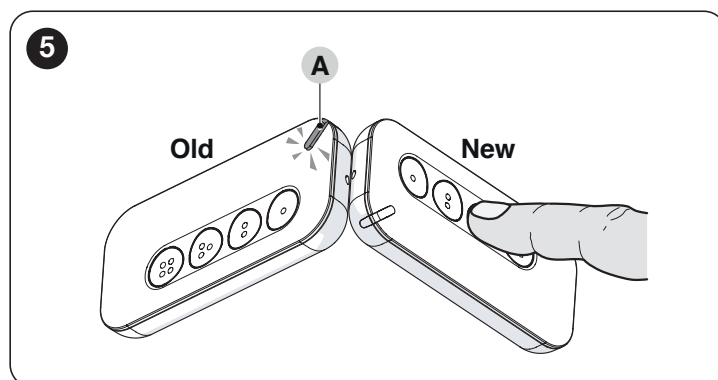

3. On the OLD transmitter press and release any command button. Once the code has been transferred, for an instant both the transmitters (NEW and OLD) will vibrate and their green LEDs (A) will light up (end of the procedure).

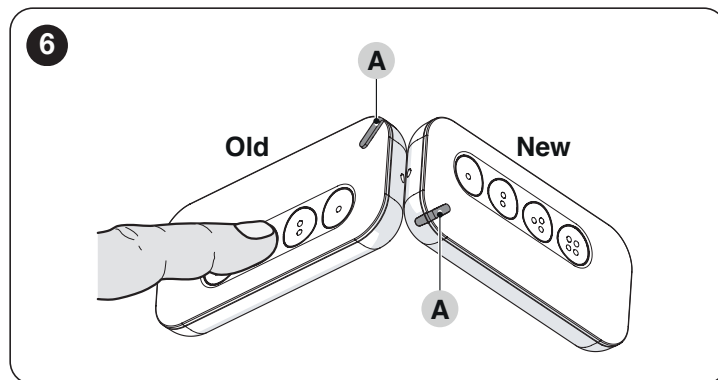

 After passing the enabling code on the NEW transmitter, for the procedure to succeed the transmitter - within the first 20 transmissions - must be used at least once near the automation.

4 STATUS REQUEST PROCEDURE

The following procedure can be used to know the automation's status through the transmitter (for example, whether the gate is open or closed).

To request the status:

1. press and release the "Status request" button/LED (A)
2. press and release the command button associated with the automation for which the status is being requested
3. observe the colour of LED (A):
 - **GREEN:** gate/door OPEN
 - **RED:** gate/door CLOSED
 - **ORANGE:** partial opening/closing
 - **RED FLASHING and INTERMITTENT VIBRATION:** control unit anomaly.

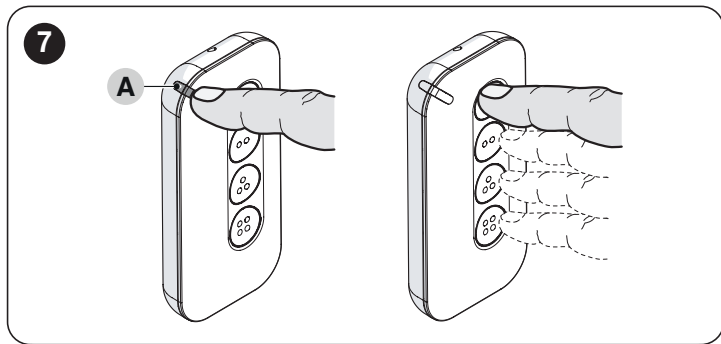

If the transmitter is memorised in multiple automations and a status request is made, the transmitter will only signal the status of the automation that responded first to the status request or that falls within the transmitter's range. In this specific case, Nice S.p.A. cannot offer any guarantee regarding the status of all the automations.

5 ENCODING SWITCH PROCEDURE

This procedure allows for modifying the type of encoding system ("O-Code", "O-Code/A" or "BD") associated with a single command button.

MYGOBD (MYGOBD/A) is configured by default in two-way mode with "BD" radio encoding. If the system's automation uses the one-way "O-code" ("O-Code/A") encoding system, the "encoding switch" procedure must be carried out for each command control to be associated with the automation.

To perform this procedure:

1. identify the button to be associated with the automation on the transmitter
2. press and release the (A) button/LED 3 times
3. press and hold for 3 seconds the command button chosen at Point 1
4. the **RED LED (A)** indicates that the "O-Code" ("O-Code/A") one-way encoding has been set.

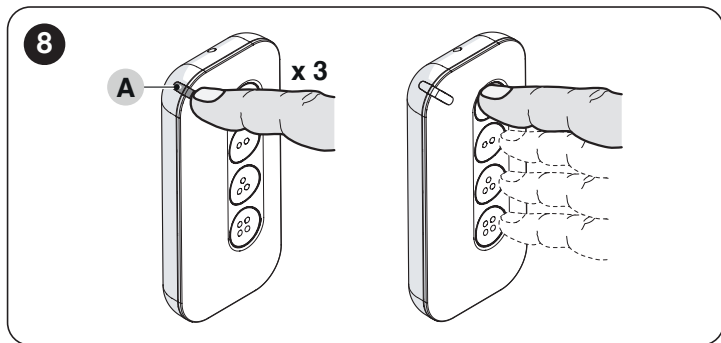

To restore the "BD" two-way encoding, repeat the procedure: the GREEN LED will signal that the "BD" encoding has been set.



A command button can only be memorised in multiple automations if the same radio technology is used (either one-way or two-way).



Each single encoding allows for exploiting only the functions linked to that specific encoding system.

6 DELETION PROCEDURE



This procedure can be used to restore the transmitter's factory conditions. At the end of the procedure, all the previously memorised settings will be lost.

To perform this procedure:

1. press and release the (A) button/LED 5 times
2. press and hold any control button until the **RED LED (A)** lights up; then release the button
3. press and release the same command button within 3 seconds: LED (A) will signal the deletion with **RED FLASHES**.

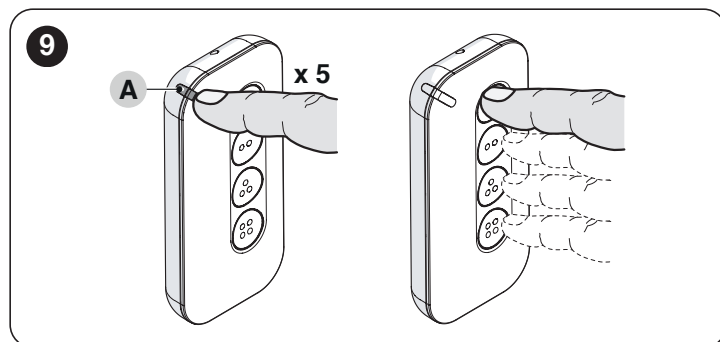

7 REPLACING THE BATTERY

When the battery is flat and a button is pressed, the corresponding signalling LED fades and the transmitter will not transmit. With the battery almost flat, the signalling LED emits red flashes during the transmission process.

To restore normal transmitter operation, replace the battery with a version of the same type, while observing the polarity.

To change the battery:

1. insert a hairpin (or similar object) through hole (A) to unlock the shell (B) and remove it
2. remove the battery and replace it with another of the same type.



When inserting the new battery, be careful to respect the polarity.

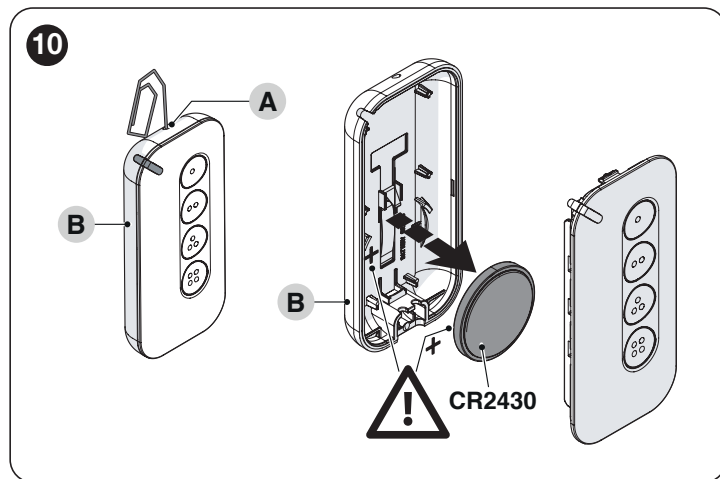

8 PRODUCT DISPOSAL

 **This product is an integral part of the operator and must therefore be disposed of with it.**

As with the installation, only qualified personnel must dismantle the product at the end of its life.

This product is composed of different types of materials. Some of these materials can be recycled; others must be disposed of. Please enquire about the recycling or disposal systems in place in your local area for this type of product.

WARNING

Some parts of the product may contain polluting or dangerous substances. If not disposed of correctly, these substances may have a damaging effect on the environment and human health.

 As indicated by the symbol shown here, this product must not be disposed of with household waste. Separate the waste for disposal and recycling, following the methods stipulated by local regulations, or return the product to the seller when purchasing a new product.

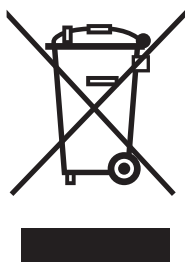

WARNING

Local regulations may impose heavy penalties if this product is not disposed of in compliance with the law.

8.1 BATTERY DISPOSAL

WARNING

The batteries must be removed from the appliance prior to its disposal.

The batteries must be disposed of in a safe way.

The flat battery contains toxic substances and must not be disposed of with common waste. Dispose of according to separate waste collection methods as envisaged by current local standards.

9 TECHNICAL SPECIFICATIONS

 All technical specifications stated in this section refer to an ambient temperature of 20°C (± 5°C). Nice S.p.A. reserves the right to apply modifications to the product at any time when deemed necessary, without altering its functions and intended use.

 The range of transmitters and the reception capacity of the receivers are heavily affected by other devices (alarms, headphones, etc.) operating on the same frequency in your area. Under such conditions, Nice S.p.A. cannot provide any guarantee with regard to the actual range of its devices.

Table 1

TECHNICAL SPECIFICATIONS	
Description	Technical specification
	MYGOBD (MYGOBD/A)
Product type	Two-way transmitter
Power supply	3 Vdc lithium battery type CR2430
Battery life	approx. 3 years, with 10 command transmissions per day
Frequency	433.92 MHz
Radiated power (ERP)	< 10 mW
Radio encoding	BD - O-Code - O-Code/A
Operating temperature	-5°C ... +55 °C
Protection rating	IP 40 (suitable for use at home indoors or in outdoor areas under cover)
Dimensions	72 x 34 x 110h mm
Weight	20 g

10 CONFORMITY

10.1 SIMPLIFIED EU DECLARATION OF CONFORMITY

The manufacturer, Nice S.p.A., declares that the product MYGO2BD - MYGO4BD - MYGO8BD is compliant with the directive 2014/53/UE. The full text of the EU declaration of conformity is available at the following internet address: <https://www.niceforyou.com/en/support>.

10.2 COMPLIANCE WITH THE FCC RULES (PART 15) AND WITH RSS-210 RULES

This device contains licence-exempt transmitter(s)/receiver(s) that comply with Innovation, Science and Economic Development Canada's licence-exempt RSS(s); and with Part 15 of the FCC rules of the United States of America. Operation is subject to the following two conditions: (1) This device may not cause interference. (2) This device must accept any interference, including interference that may cause undesired operation of the device. Any changes or modifications made to this device, without the express permission of the manufacturer, may void the user's authority to operate this device.

11 ACCESSORIES

11.1 STRING FOR KEYRING

The string (A), supplied as an accessory with the transmitter, is useful for fastening the transmitter itself to a keyring or other similar object. To fasten it, wrap the string around slot (B) present on the transmitter.

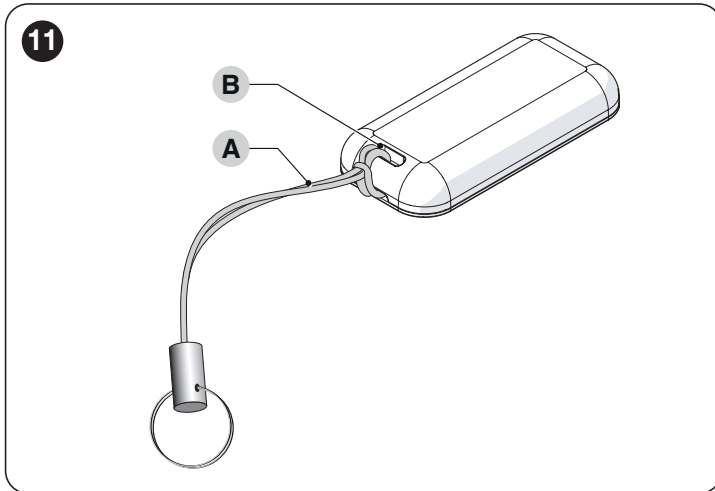

11.2 FASTENING SUPPORT

The support (A), which can be ordered separately as an accessory, can be used for fastening the transmitter to various objects such as, for example, sun shades for cars. To mount the support (A) to the transmitter, simply insert it into slot (B) until the tab (C) clicks. To remove it, insert a screwdriver or other similar tool into hole (D) and leverage on the tab (C); then remove it.

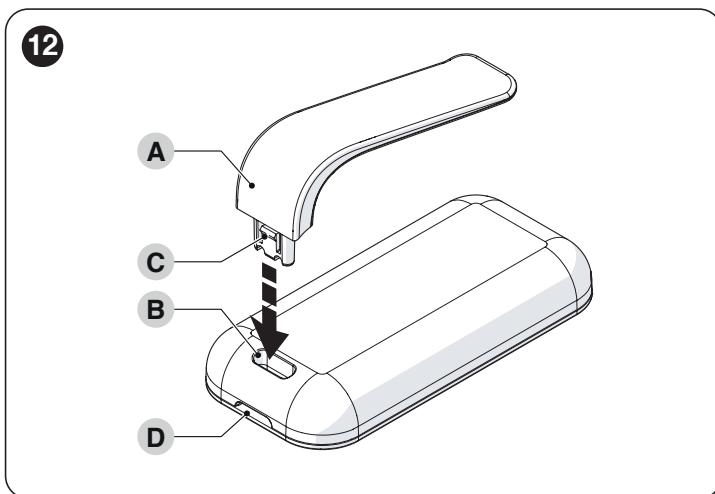



Nice SpA
Via Callalta, 1
31046 Oderzo TV Italy
info@niceforyou.com

www.niceforyou.com