



FCC TEST REPORT

FCC ID: PLE-T1-V2

On Behalf of

Gigastone Corporation.

True Wireless Bluetooth Earbuds T1

Model No.: T1

Prepared for : Gigastone Corporation.
Address : 12F, No. 480, Rueiguang Road Neihu Distrist, Taipei 114, Taiwan,
R.O.C

Prepared By : Shenzhen Alpha Product Testing Co., Ltd.
Address : Building i, No.2, Lixin Road, Fuyong Street, Bao'an District, 518103,
Shenzhen, Guangdong, China

Report Number : A2003172-C01-R01
Date of Receipt : May 12, 2020
Date of Test : May 12, 2020- May 19, 2020
Date of Report : May 19, 2020
Version Number : V0

TABLE OF CONTENTS

Description	Page
1. Summary of Standards And Results	6
1.1. Description of Standards and Results	6
2. General Information.....	7
2.1. Description of Device (EUT).....	7
2.2. Accessories of Device (EUT)	8
2.3. Tested Supporting System Details	8
2.4. Block Diagram of connection between EUT and simulators	8
2.5. Test Mode Description.....	8
2.6. Test Conditions	8
2.7. Test Facility	9
2.8. Measurement Uncertainty.....	9
2.9. Test Equipment List.....	10
3. Maximum Peak Output power	11
3.1. Limit	11
3.2. Test Procedure	11
3.3. Test Setup.....	11
3.4. Test Result	11
4. Bandwidth.....	12
4.1. Limit	12
4.2. Test Procedure	12
4.3. Test Result	12
5. Carrier Frequency Separation.....	22
5.1. Limit	22
5.2. Test Procedure	22
5.3. Test Result	22
6. Number Of Hopping Channel.....	24
6.1. Limit	24
6.2. Test Procedure	24
6.3. Test Result	24
7. Dwell Time.....	26
7.1. Test limit	26
7.2. Test Procedure	26
7.3. Test Result	26
8. Radiated emissions.....	35
8.1. Limit	35
8.2. Block Diagram of Test setup	36
8.3. Test Procedure	37
8.4. Test Result	37
9. Band Edge Compliance	40

9.1. Block Diagram of Test Setup.....	40
9.2. Limit	40
9.3. Test Procedure	40
9.4. Test Result	40
10. Power Line Conducted Emissions	59
10.1. Block Diagram of Test Setup.....	59
10.2. Limit	59
10.3. Test Procedure	59
10.4. Test Result	59
11. Antenna Requirements.....	61
11.1. Limit	61
11.2. Result.....	61
12. Test setup photo	62
12.1. Photos of Radiated emission.....	62
12.2. Photos of Conducted Emission test	64
13. Photos of EUT	65

TEST REPORT DECLARATION

Applicant : Gigastone Corporation.
 Address : 12F, No. 480, Rueiguang Road Neihu Distrist, Taipei 114, Taiwan, R.O.C
 Manufacturer : Shenzhen Gblue Technology Co.,Ltd.
 Address : Unit B, 3rd Floor, A Building, An LiBang Science Park, XiTian Road, Guangming
 New District, Shenzhen
 EUT Description : True Wireless Bluetooth Earbuds T1
 (A) Model No. : T1
 (B) Trademark : **Gigastone**

Measurement Standard Used:

FCC Rules and Regulations Part 15 Subpart C Section 15.247
ANSI C63.10:2013

The device described above is tested by Shenzhen Alpha Product Testing Co., Ltd. to determine the maximum emission levels emanating from the device. The maximum emission levels are compared to the FCC Part 15 Subpart C limits both conducted and radiated emissions. The test results are contained in this test report and Shenzhen Alpha Product Testing Co., Ltd. is assumed of full responsibility for the accuracy and completeness of these tests.

After the test, our opinion is that EUT compliance with the requirement of the above standards.

This report applies to above tested sample only. This report shall not be reproduced in parts without written approval of Shenzhen Alpha Product Testing Co., Ltd.

Tested by (name + signature).....: Lucas Pang
 Project Engineer



Approved by (name + signature).....: Simple Guan
 Project Manager



Date of issue..... : May 19,2020

Revision History

Revision	Issue Date	Revisions	Revised By
V0	May 19,2020	Initial released Issue	Lucas Pang

1. SUMMARY OF STANDARDS AND RESULTS

1.1. Description of Standards and Results

The EUT have been tested according to the applicable standards as referenced below:

Test Item	Standards Paragraph	Result
Maximum Peak Output Power	FCC Part 15: 15.247(b)(1) ANSI C63.10 :2013	P
Bandwidth	FCC Part 15: 15.215 ANSI C63.10 :2013	P
Carrier Frequency Separation	FCC Part 15: 15.247(a)(1) ANSI C63.10 :2013	P
Number Of Hopping Channel	FCC Part 15: 15.247(a)(1)(iii) ANSI C63.10 :2013	P
Dwell Time	FCC Part 15: 15.247(a)(1)(iii) ANSI C63.10 :2013	P
Radiated Emission	FCC Part 15: 15.209 FCC Part 15: 15.247(d) ANSI C63.10 :2013	P
Band Edge Compliance	FCC Part 15: 15.247(d) ANSI C63.10 :2013	P
Power Line Conducted Emissions	FCC Part 15: 15.207 ANSI C63.10 :2013	P
Antenna requirement	FCC Part 15: 15.203	P
Note:	1. P is an abbreviation for Pass. 2. F is an abbreviation for Fail. 3. N/A is an abbreviation for Not Applicable.	

2. GENERAL INFORMATION

2.1. Description of Device (EUT)

Description	: True Wireless Bluetooth Earbuds T1
Trademark	: Gigastone
Model Number	: T1
DIFF.	: N/A
Test Voltage	: DC 5V from PC / DC 3.7V From Battery
Radio Technology	: Bluetooth V5.0
Operation frequency	: 2402-2480MHz
Channel No.	: 79 Channels
Modulation type	: GFSK, $\pi/4$ DQPSK, 8DPSK
Antenna Type	: PCB antenna, Maximum Gain is 3.20dBi
Software version	: V3.2
Hardware version	: V2.1

- Note: 1. The product contains two earbuds with identical functions, which can be used in pairs.
2. Both modules have been tested, and this report only shows the worst data.

2.2. Accessories of Device (EUT)

Accessories1 : /
 Manufacturer : /
 Model : /
 Ratings : /

2.3. Tested Supporting System Details

No.	Description	Manufacturer	Model	Serial Number	Certification
1.	Notebook	N/A	N/A	N/A	N/A

2.4. Block Diagram of connection between EUT and simulators

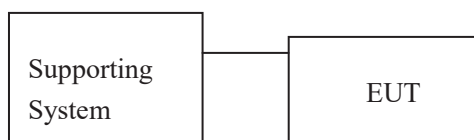

2.5. Test Mode Description

Tested mode, channel, and data rate information		
Mode	Channel	Frequency (MHz)
GFSK	Low :CH1	2402
	Middle: CH40	2441
	High: CH79	2480
π /4 DQPSK	Low :CH1	2402
	Middle: CH40	2441
	High: CH79	2480
8- DPSK	Low :CH1	2402
	Middle: CH40	2441
	High: CH79	2480

2.6. Test Conditions

Items	Required	Actual
Temperature range:	15-35°C	24°C
Humidity range:	25-75%	56%
Pressure range:	86-106kPa	98kPa

2.7. Test Facility

Shenzhen Alpha Product Testing Co., Ltd

Building i, No.2, Lixin Road, Fuyong Street, Bao'an District, 518103,
Shenzhen, Guangdong, China

June 21, 2018 File on Federal Communication Commission

Registration Number: 293961

July 15, 2019 Certificated by IC

Registration Number: CN0085

2.8. Measurement Uncertainty

(95% confidence levels, k=2)

Item	Uncertainty
Uncertainty for Power point Conducted Emissions Test	2.74dB
Uncertainty for Radiation Emission test in 3m chamber (below 30MHz)	2.13 dB(Polarize: V)
	2.57dB(Polarize: H)
Uncertainty for Radiation Emission test in 3m chamber (30MHz to 1GHz)	3.77dB(Polarize: V)
	3.80dB(Polarize: H)
Uncertainty for Radiation Emission test in 3m chamber (1GHz to 25GHz)	4.13dB(Polarize: H)
	4.16dB(Polarize: V)
Uncertainty for radio frequency	5.4×10^{-8}
Uncertainty for conducted RF Power	0.37dB
Uncertainty for temperature	0.2°C
Uncertainty for humidity	1%
Uncertainty for DC and low frequency voltages	0.06%

2.9. Test Equipment List

Equipment	Manufacture	Model No.	Serial No.	Last cal.	Cal Interval
9*6*6 anechoic chamber	CHENYU	9*6*6	N/A	2019.09.06	1Year
Spectrum analyzer	ROHDE&SCHWARZ	FSU	1166.1660.26	2019.09.06	1Year
Spectrum analyzer	Agilent	N9020A	MY499100060	2019.09.05	1Year
Receiver	ROHDE&SCHWARZ	ESR	1316.3003K03-10208 2-Wa	2019.09.06	1Year
Receiver	R&S	ESCI	101165	2019.09.05	1Year
Bilog Antenna	Schwarzbeck	VULB 9168	VULB9168-438	2019.09.07	2Year
Horn Antenna	SCHWARZBECK	BBHA 9120 D	BBHA 9120 D(1201)	2020.04.12	2Year
Loop Antenna	SCHWARZBECK	FMZB 1519B	00059	2019.09.07	2Year
Cable	Resenberger	N/A	No.1	2019.09.05	1Year
Cable	SCHWARZBECK	N/A	No.2	2019.09.05	1Year
Cable	SCHWARZBECK	N/A	No.3	2019.09.05	1Year
Pre-amplifier	HP	HP8347A	2834A00455	2019.09.05	1Year
Pre-amplifier	Agilent	8449B	3008A02664	2019.09.05	1Year
Temperature controller	Terchy	MHQ	120	2019.09.20	1Year
L.I.S.N.#1	Schwarzbeck	NSLK8126	8126-466	2019.09.05	1Year
L.I.S.N.#2	ROHDE&SCHWARZ	ENV216	101043	2019.09.05	1 Year
20db Attenuator	ICPROBING	IATS1	82347	2019.09.20	1 Year

3. MAXIMUM PEAK OUTPUT POWER

3.1.Limit

Please refer section 15.247.

For frequency hopping systems operating in the 2400-2483.5 MHz band employing at least 75 non-overlapping hopping channels, and all frequency hopping systems in the 5725-5850 MHz band: 1 watt. For all other frequency hopping systems in the 2400-2483.5 MHz band: 0.125 watts, the e.i.r.p shall not exceed 4W

3.2.Test Procedure

The transmitter output is connected to the RF Power Meter. The RF Power Meter is set to the average power detection.

3.3.Test Setup

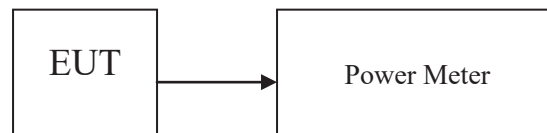

3.4.Test Result

Mode	Freq (MHz)	Average Output Power (dBm)	Limit (dBm)	Result
GFSK	2402	-2.708	21	Pass
	2441	-0.969	21	Pass
	2480	-0.287	21	Pass
Conclusion: PASS				

Remark: All modes have been tested, and only worst data of (GFSK) was listed in this report.

4. BANDWIDTH

4.1.Limit

Intentional radiators operating under the alternative provisions to the general emission limits, as contained in §§ 15.217 through 15.257 and in Subpart E of this part, must be designed to ensure that the 20 dB bandwidth of the emission, or whatever bandwidth may otherwise be specified in the specific rule section under which the equipment operates, is contained within the frequency band designated in the rule section under which the equipment is operated.

4.2.Test Procedure

The RF output of EUT was connected to the spectrum analyzer by RF cable and attenuator. The bandwidth of the fundamental frequency was measured by spectrum analyzer with 30kHz RBW and 100kHz VBW. The 20dB bandwidth is defined as the total spectrum the power of which is higher than peak power minus 20dB.

4.3.Test Result

Condition	Mode	Frequency (MHz)	99% OBW (MHz)	-20 dB Bandwidth (MHz)	Limit -20 dB Bandwidth (MHz)	Verdict
NVNT	GFSK	2402	0.9543	0.9564	/	Pass
NVNT	GFSK	2441	0.9511	0.95	/	Pass
NVNT	GFSK	2480	0.9809	0.9586	/	Pass
NVNT	$\pi/4$ DQPSK	2402	1.2045	1.366	/	Pass
NVNT	$\pi/4$ DQPSK	2441	1.1997	1.3656	/	Pass
NVNT	$\pi/4$ DQPSK	2480	1.2019	1.3604	/	Pass
NVNT	8DPSK	2402	1.2149	1.3508	/	Pass
NVNT	8DPSK	2441	1.2095	1.349	/	Pass
NVNT	8DPSK	2480	1.2003	1.3464	/	Pass

OBW NVNT 1-DH1 2402MHz

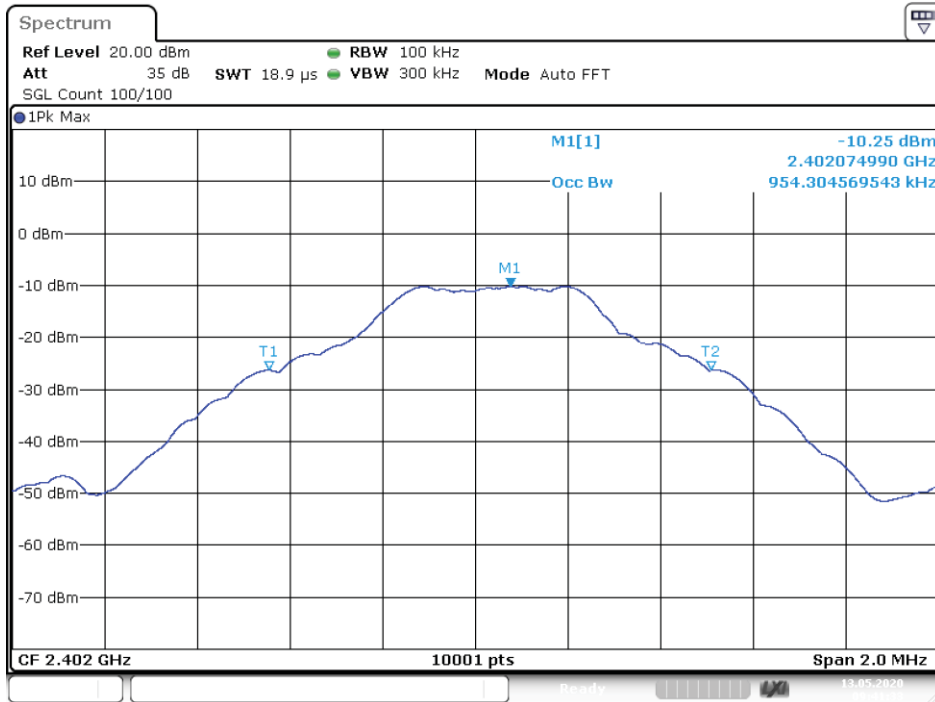

-20 dB BW NVNT 1-DH1 2402MHz

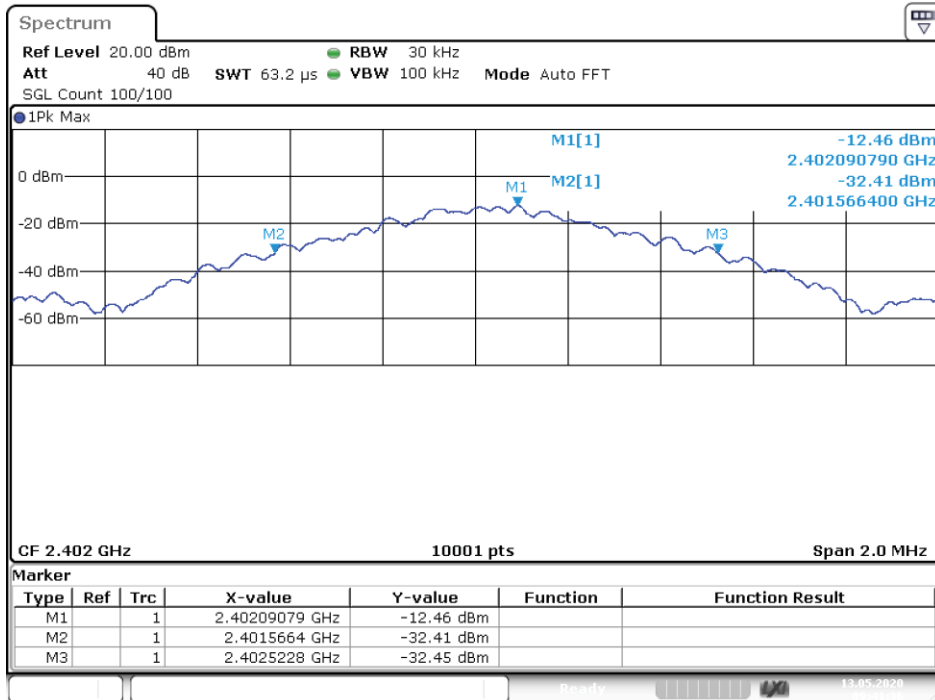

OBW NVNT 1-DH1 2441MHz

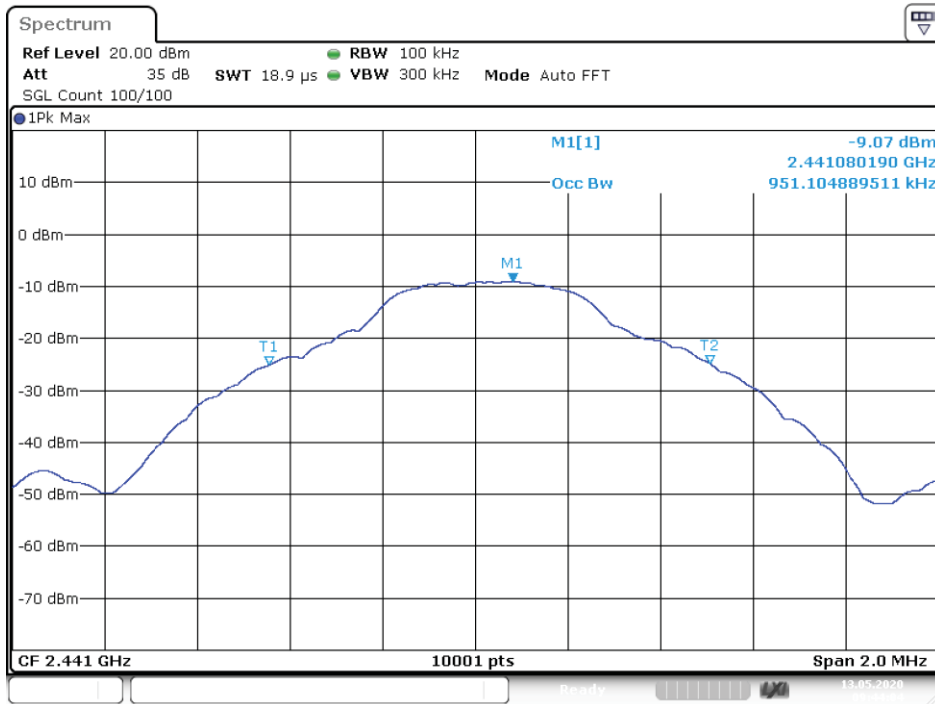

Date: 13.MAY.2020 09:44:04

-20 dB BW NVNT 1-DH1 2441MHz

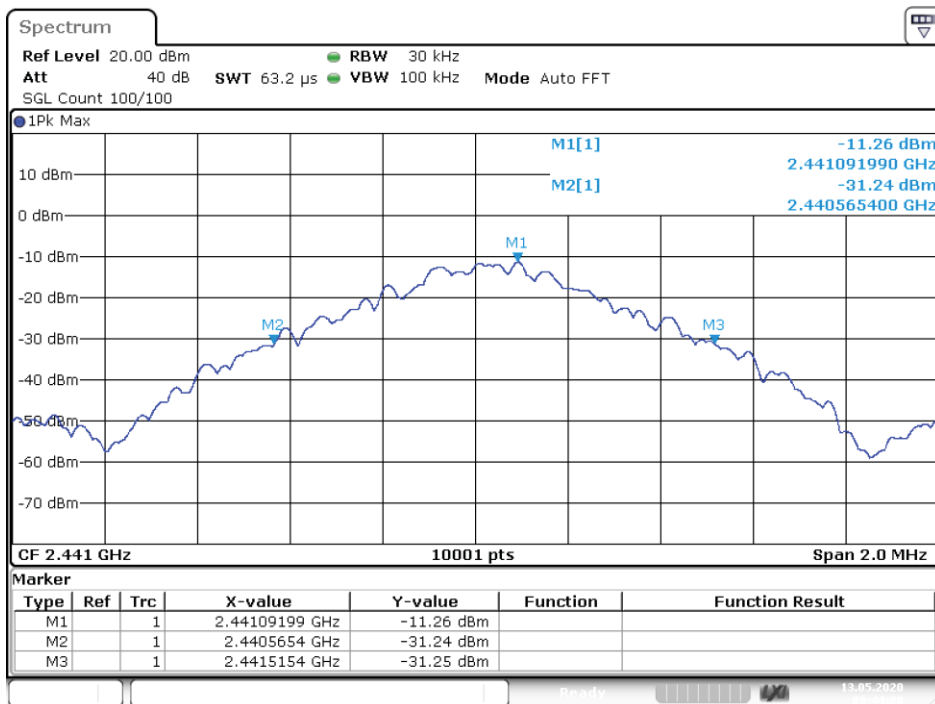

Date: 13.MAY.2020 09:44:07

OBW NVNT 1-DH1 2480MHz

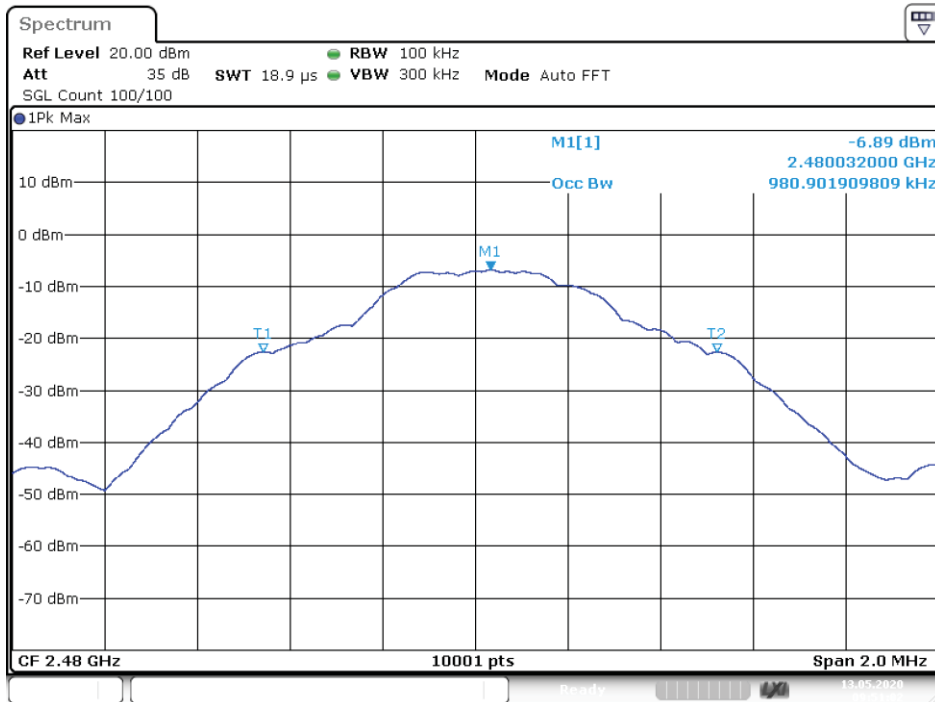

Date: 13.MAY.2020 09:51:02

-20 dB BW NVNT 1-DH1 2480MHz

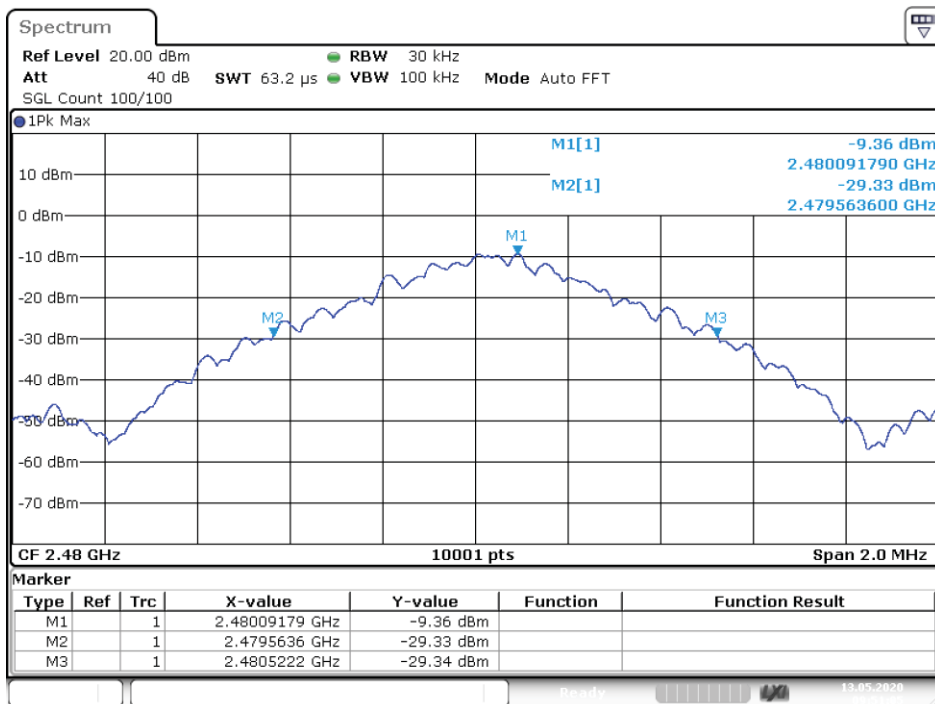

Date: 13.MAY.2020 09:51:05

OBW NVNT 2-DH1 2402MHz

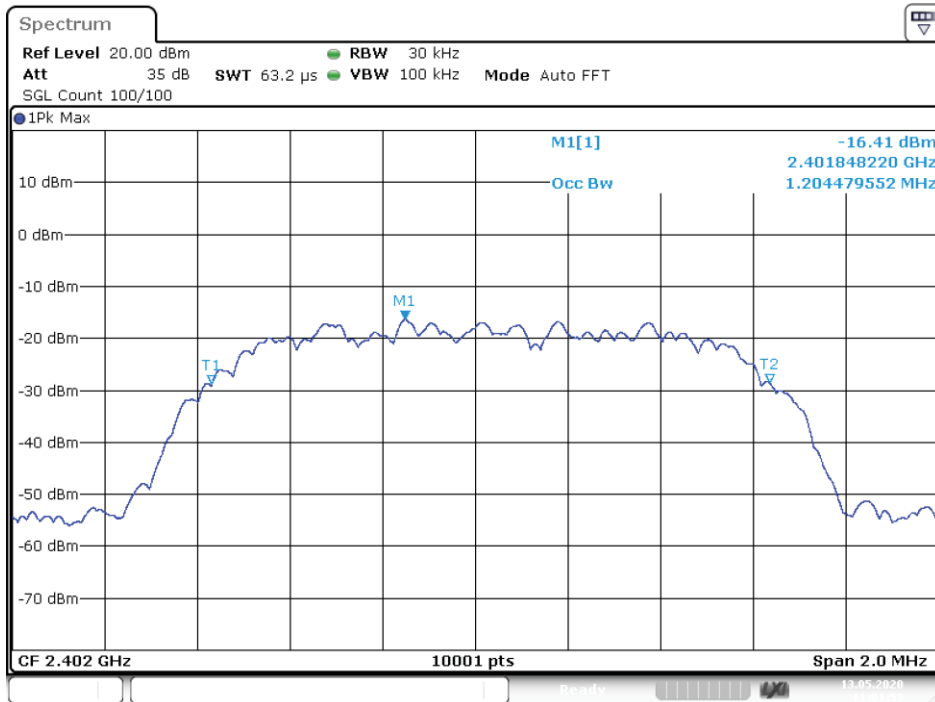

Date: 13.MAY.2020 11:01:52

-20 dB BW NVNT 2-DH1 2402MHz

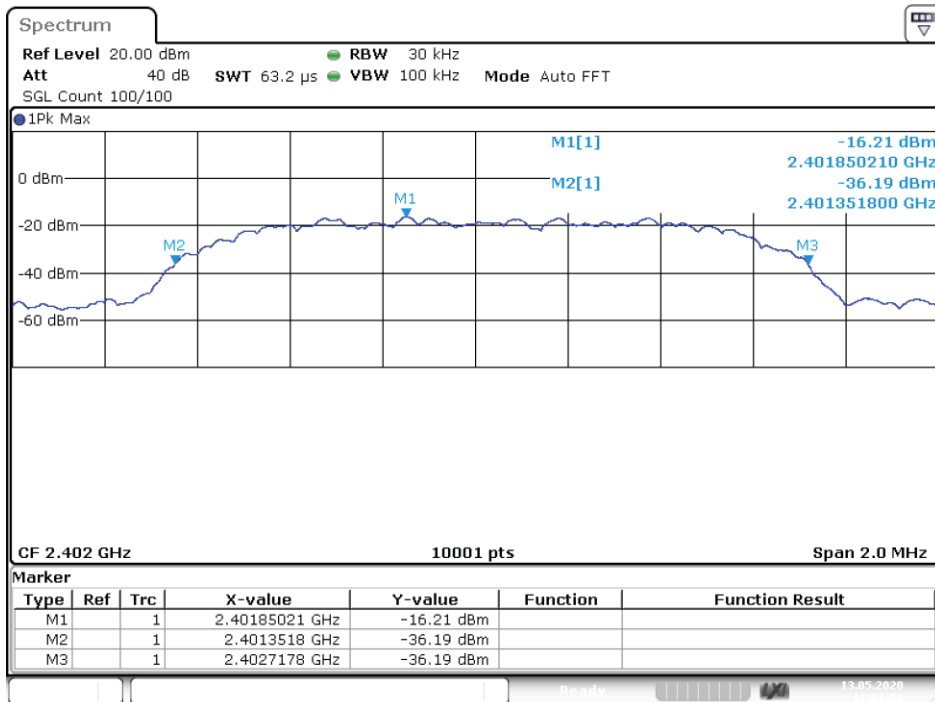

Date: 13.MAY.2020 11:01:55

OBW NVNT 2-DH1 2441MHz

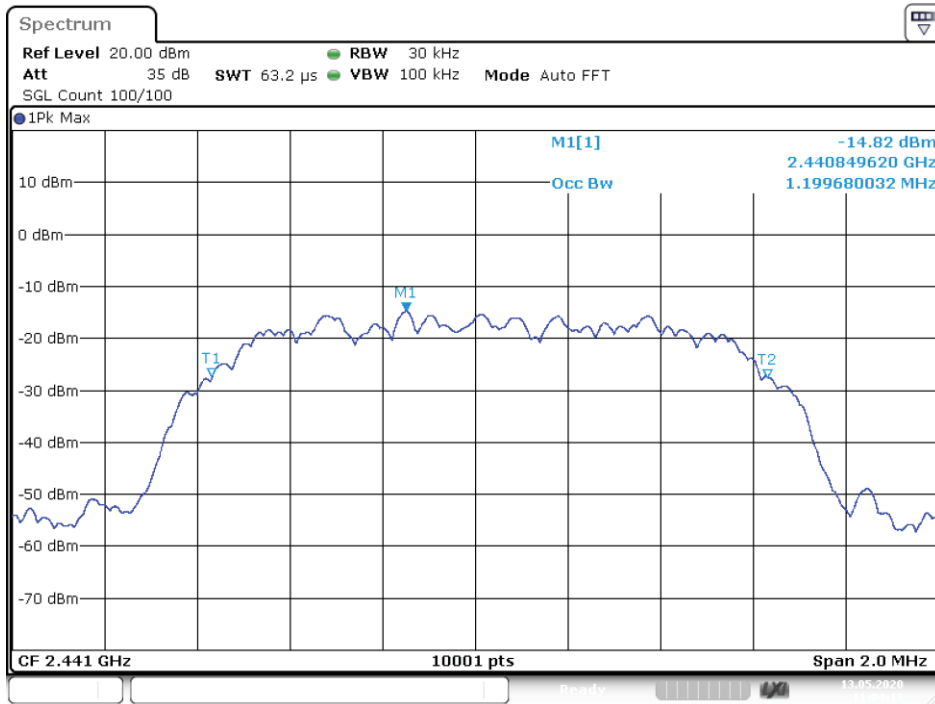

Date: 13.MAY.2020 11:04:13

-20 dB BW NVNT 2-DH1 2441MHz

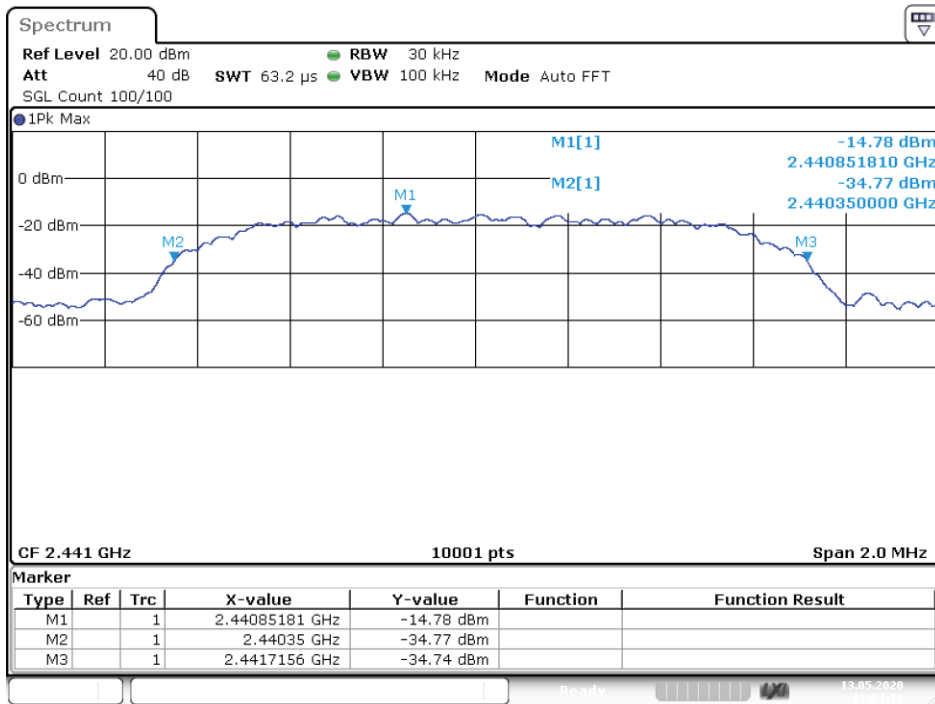

Date: 13.MAY.2020 11:04:16

OBW NVNT 2-DH1 2480MHz

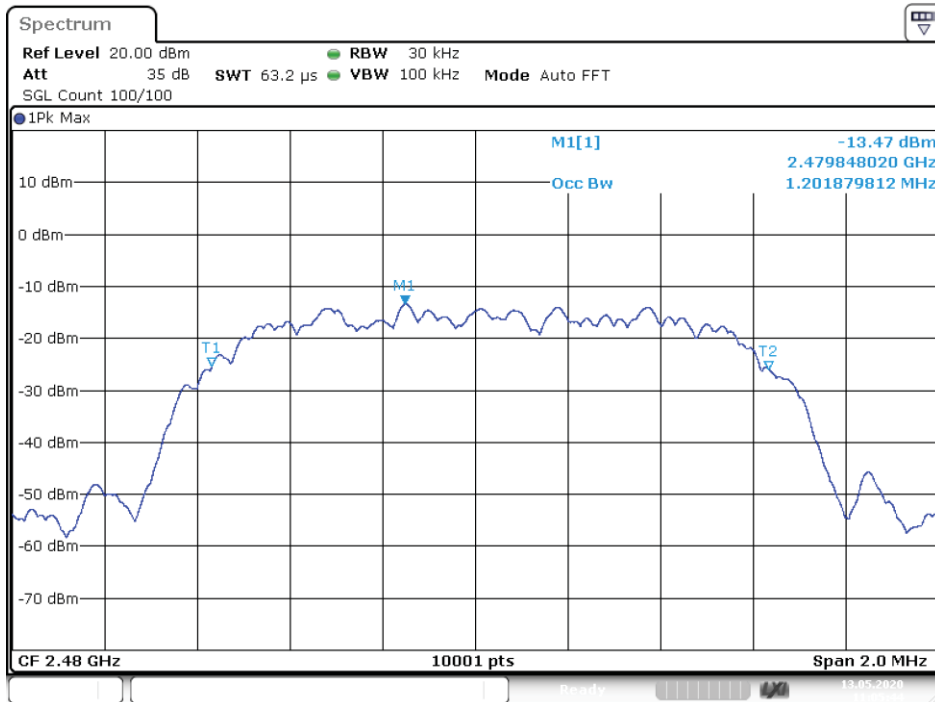

Date: 13.MAY.2020 11:05:44

-20 dB BW NVNT 2-DH1 2480MHz

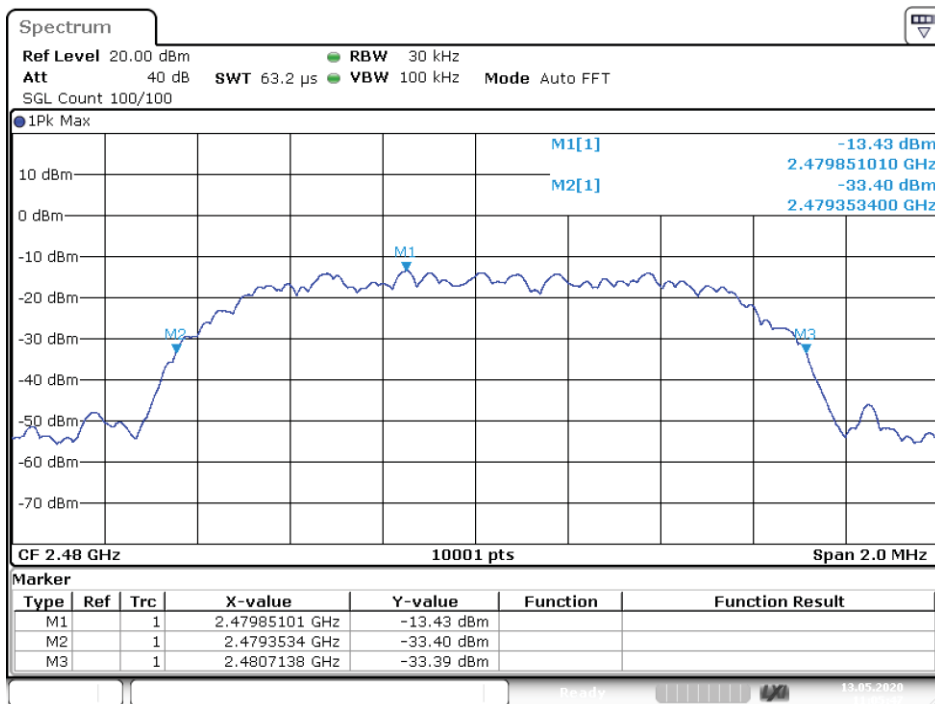

Date: 13.MAY.2020 11:05:47

OBW NVNT 3-DH1 2402MHz

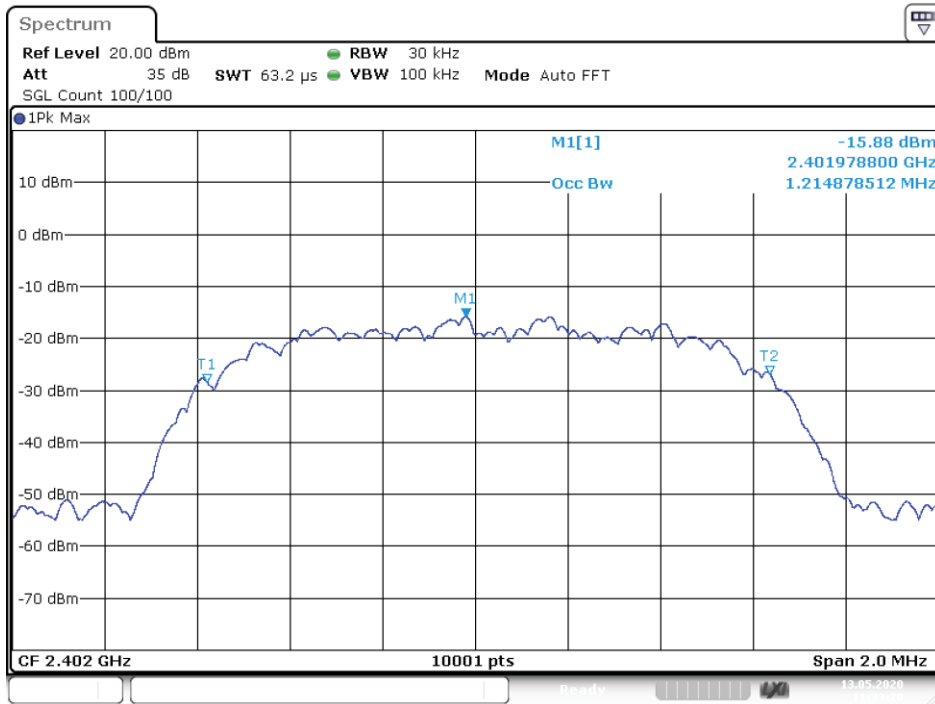

Date: 13.MAY.2020 11:33:19

-20 dB BW NVNT 3-DH1 2402MHz

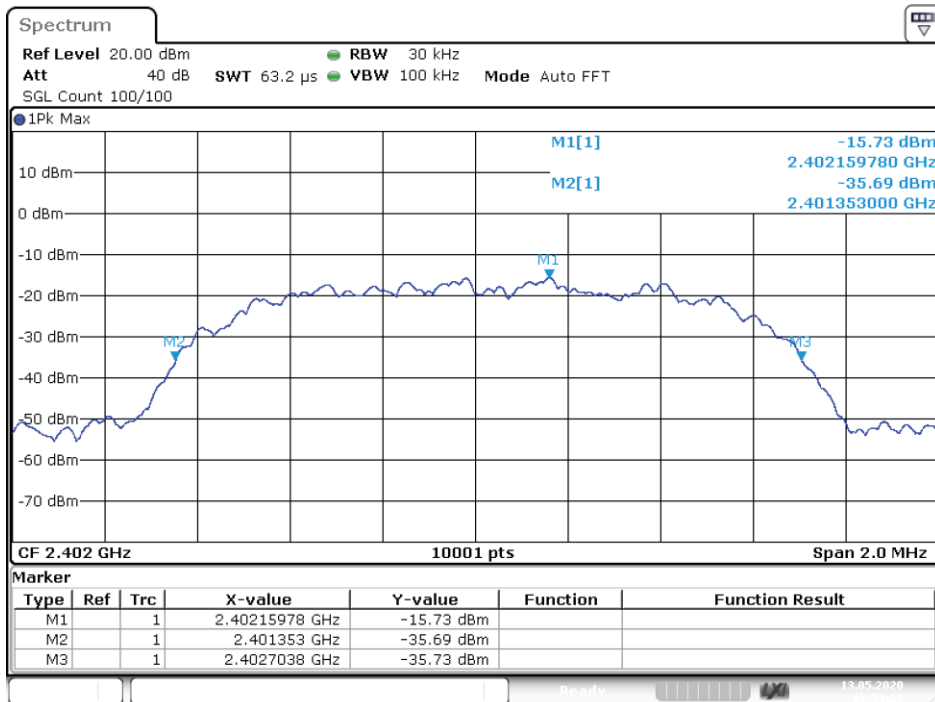

Date: 13.MAY.2020 11:33:23

OBW NVNT 3-DH1 2441MHz

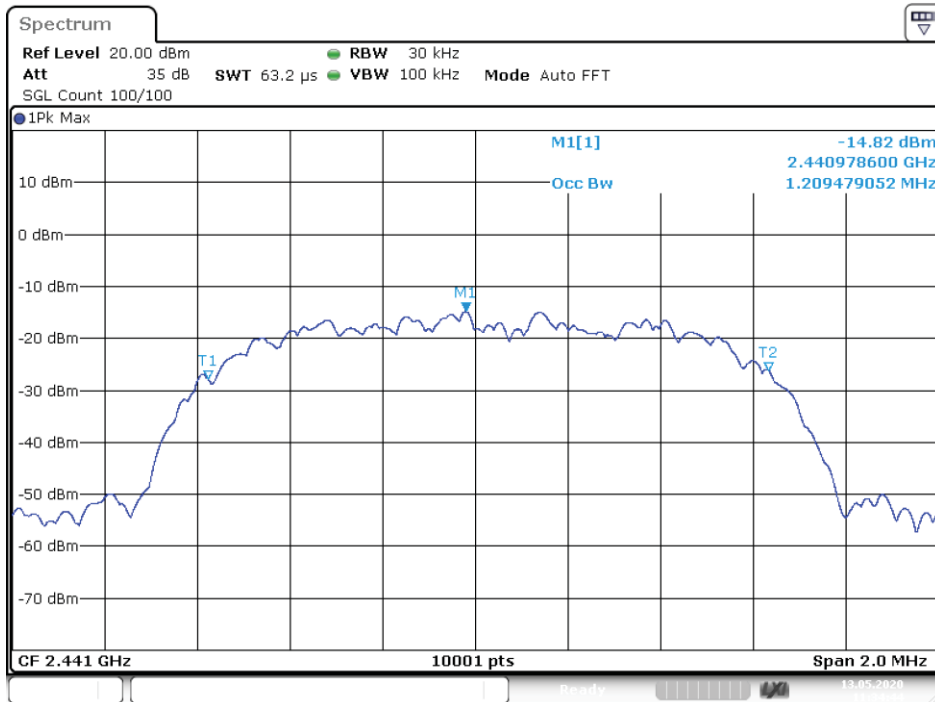

Date: 13.MAY.2020 11:34:44

-20 dB BW NVNT 3-DH1 2441MHz

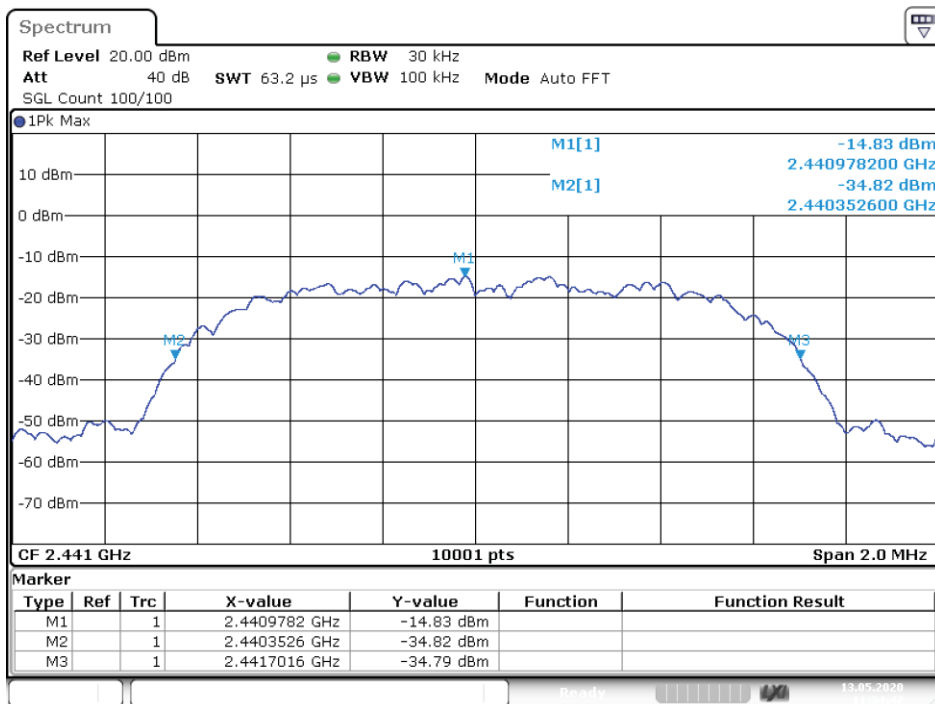

Date: 13.MAY.2020 11:34:47

OBW NVNT 3-DH1 2480MHz

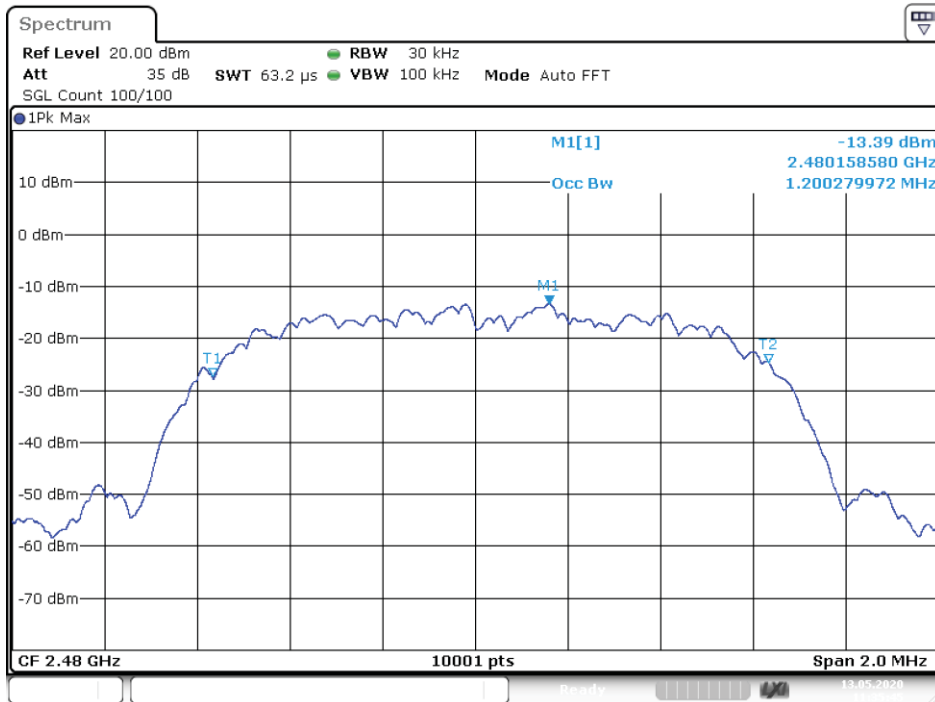

Date: 13.MAY.2020 11:35:45

-20 dB BW NVNT 3-DH1 2480MHz

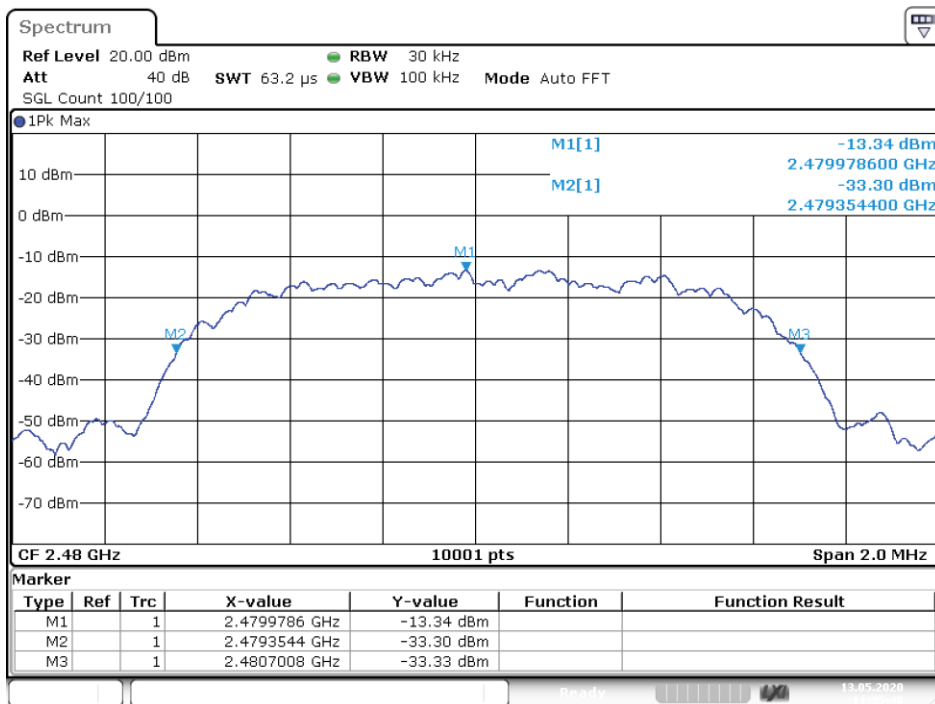

Date: 13.MAY.2020 11:35:48

5. CARRIER FREQUENCY SEPARATION

5.1. Limit

Frequency hopping systems shall have hopping channel carrier frequencies separated by a minimum of 25 kHz or the 20 dB bandwidth of the hopping channel, whichever is greater. Alternatively, frequency hopping systems operating in the 2400-2483.5 MHz band may have hopping channel carrier frequencies that are separated by 25 kHz or two-thirds of the 20 dB bandwidth of the hopping channel, whichever is greater, provided the systems operate with an output power no greater than 125 mW

5.2. Test Procedure

The RF output of EUT was connected to the spectrum analyzer by RF cable and attenuator. The carrier frequency was measured by spectrum analyzer with 20kHz RBW and 62kHz VBW.

5.3. Test Result

Condition	Mode	Hopping Freq1 (MHz)	Hopping Freq2 (MHz)	HFS (MHz)	Limit (MHz)	Verdict
NVNT	1-DH1	2441.036	2442.04	1.004	0.639	Pass
NVNT	2-DH1	2441.059	2442.187	1.128	0.639	Pass
NVNT	3-DH1	2441.047	2442.031	0.984	0.907	Pass

CFS NVNT 1-DH1 2441MHz

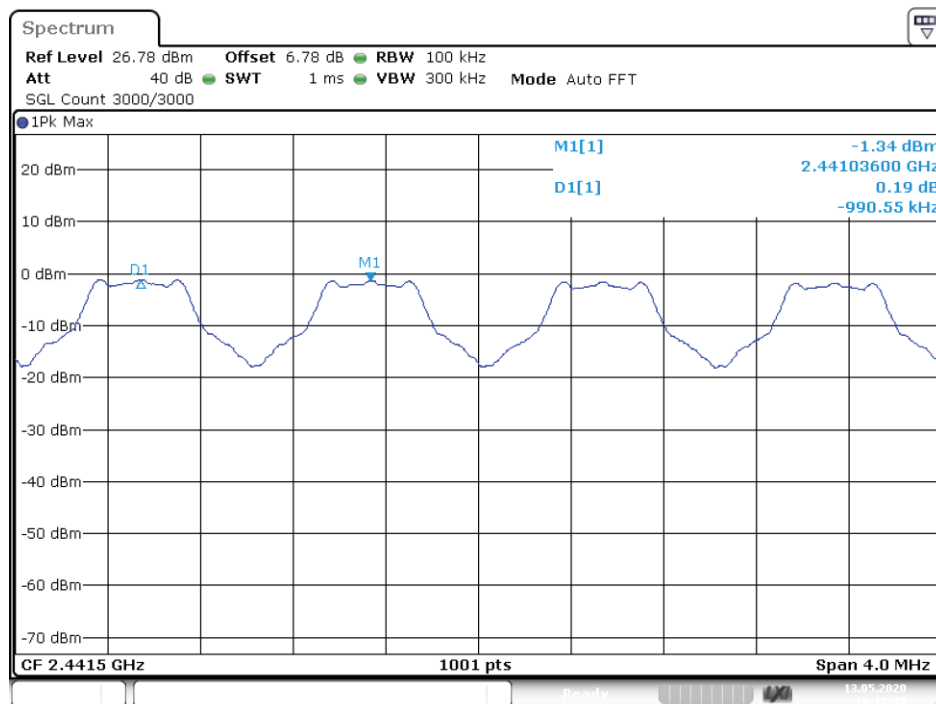

Date: 13.MAY.2020 10:12:38

CFS NVNT 2-DH1 2441MHz

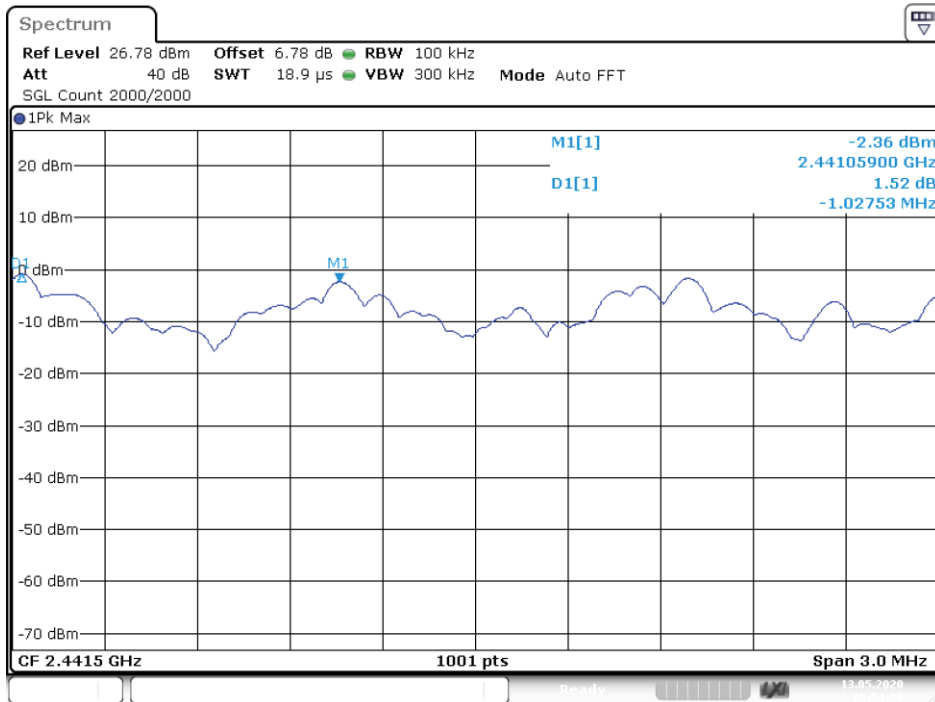

CFS NVNT 3-DH1 2441MHz

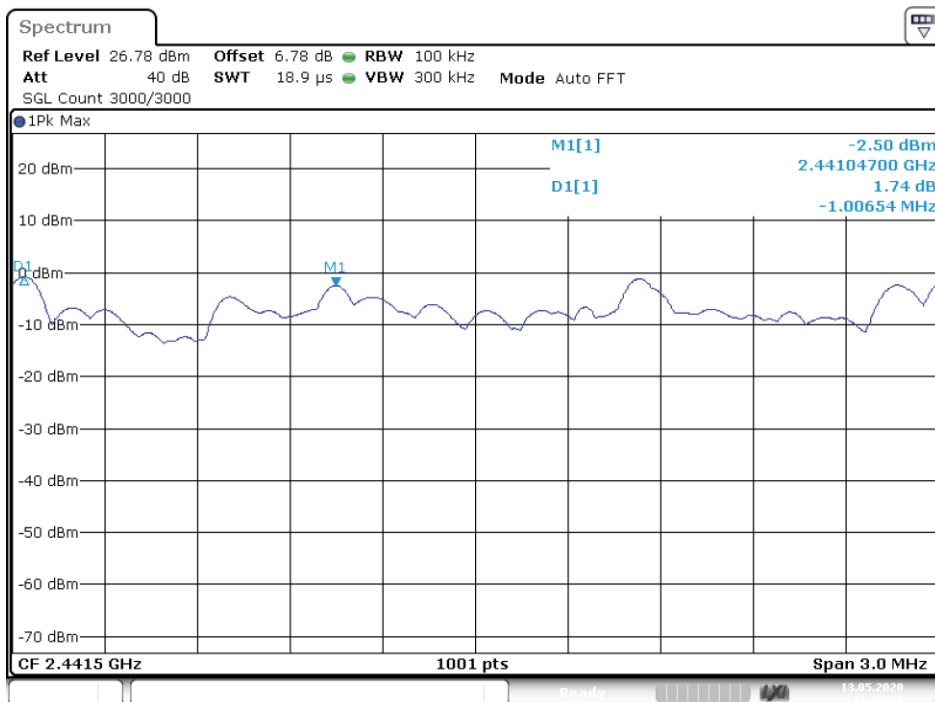

6. NUMBER OF HOPPING CHANNEL

6.1.Limit

Frequency hopping systems in the 2400-2483.5 MHz band shall use at least 15 channels

6.2.Test Procedure

The RF output of EUT was connected to the spectrum analyzer by RF cable and attenuator. The number of hopping channel was measured by spectrum analyzer with 100kHz RBW and 300KHz VBW.

6.3.Test Result

Condition	Mode	Hopping Number	Limit	Verdict
NVNT	1-DH1	79	15	Pass
NVNT	2-DH1	79	15	Pass
NVNT	3-DH1	79	15	Pass

Hopping No. NVNT 1-DH1 2441MHz

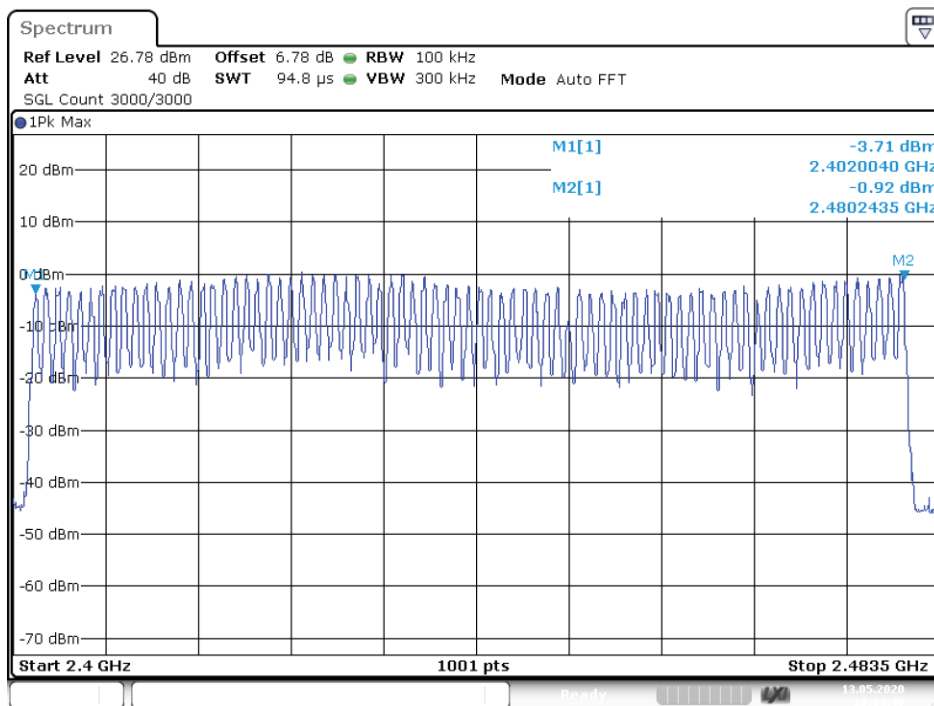

Date: 13.MAY.2020 10:14:40

Hopping No. NVNT 2-DH1 2441MHz

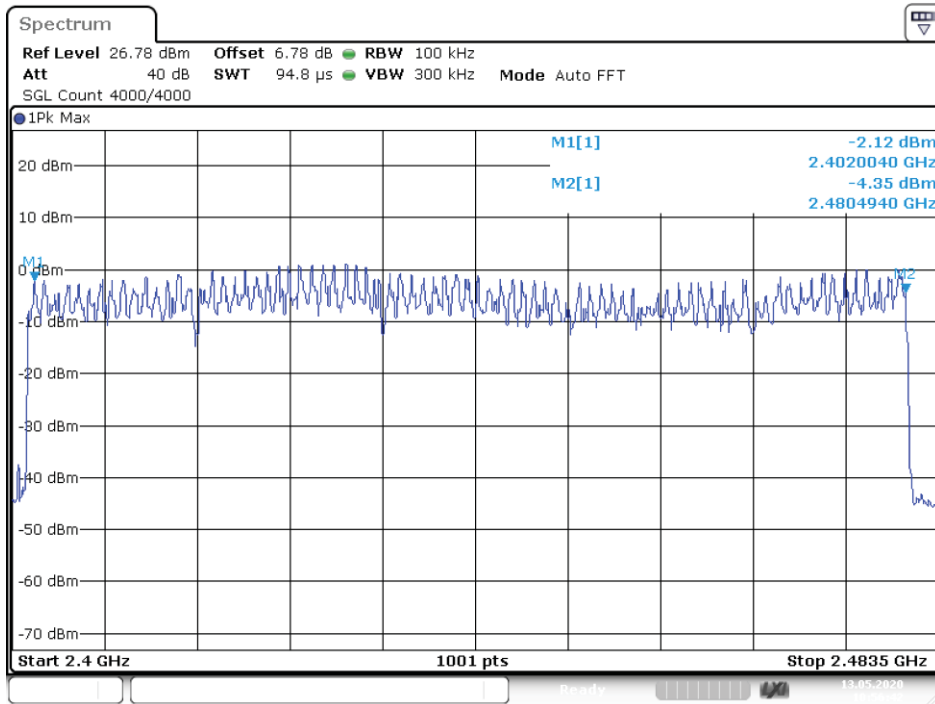

Hopping No. NVNT 3-DH1 2441MHz

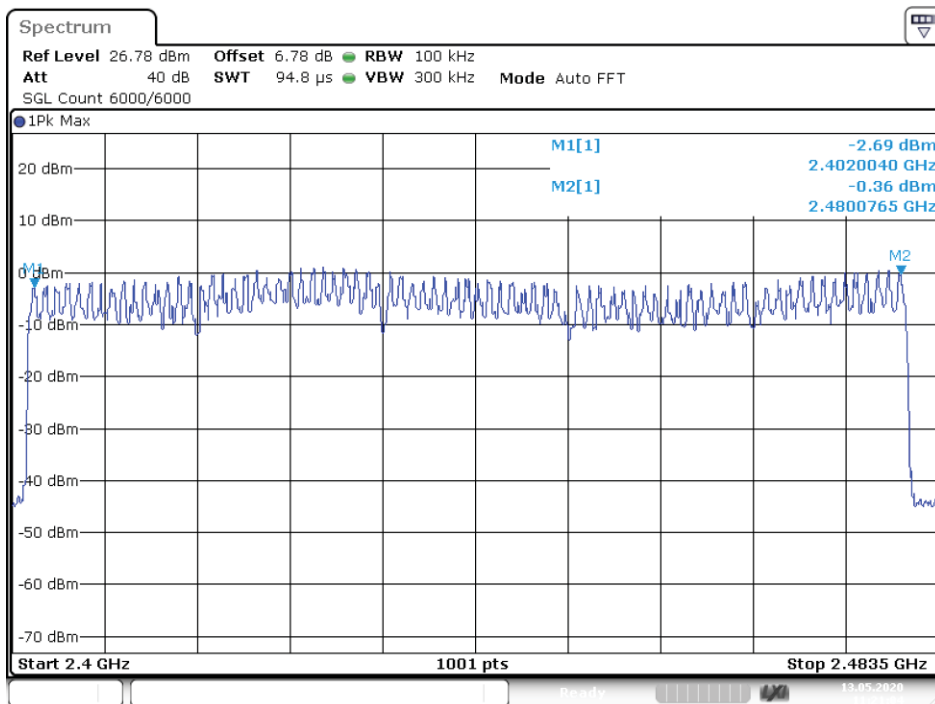

7. DWELL TIME

7.1. Test limit

Please refer section 15.247

According to §15.247(a)(1)(iii), Frequency hopping systems operating in the 2400MHz-2483.5 MHz. The average time of occupancy on any frequency shall not be greater than 0.4 s within period of 0.4 seconds multiplied by the number of hopping channels employed.

7.2. Test Procedure

7.2.1. Place the EUT on the table and set it in transmitting mode.

7.2.2. Remove the antenna from the EUT and then connect a low loss RF cable from the antenna port to the spectrum analyzer.

7.2.3. Set center frequency of spectrum analyzer = operating frequency.

7.2.4. Set the spectrum analyzer as RBW=1MHz, VBW=1MHz, Span = 0Hz, Sweep = auto.

7.2.5. Repeat above procedures until all frequency measured were complete.

7.3. Test Result

PASS.

Condition	Mode	Frequency (MHz)	Pulse Time (ms)	Total Dwell Time (ms)	Period Time (ms)	Limit (ms)	Verdict
NVNT	1-DH1	2402	0.382	122.24	31600	400	Pass
NVNT	1-DH1	2441	0.382	122.24	31600	400	Pass
NVNT	1-DH1	2480	0.382	122.24	31600	400	Pass
NVNT	1-DH3	2441	1.638	262.08	31600	400	Pass
NVNT	1-DH5	2441	2.885	307.73	31600	400	Pass
NVNT	2-DH1	2402	0.37	118.4	31600	400	Pass
NVNT	2-DH1	2441	0.375	120	31600	400	Pass
NVNT	2-DH1	2460	0.391	125.12	31600	400	Pass
NVNT	2-DH3	2441	1.642	262.72	31600	400	Pass
NVNT	2-DH5	2441	2.872	306.35	31600	400	Pass
NVNT	3-DH1	2402	0.391	125.12	31600	400	Pass
NVNT	3-DH1	2441	0.391	125.12	31600	400	Pass
NVNT	3-DH1	2480	0.372	119.04	31600	400	Pass
NVNT	3-DH3	2441	1.622	259.52	31600	400	Pass
NVNT	3-DH5	2441	2.872	306.35	31600	400	Pass

Note: 1 A period time = 0.4 (s) * 79 = 31.6(s)

2 DH1 time slot = Pulse Duration * (1600/(2*79)) * A period time/1000

DH3 time slot = Pulse Duration * (1600/(4*79)) * A period time/1000

DH5 time slot = Pulse Duration * (1600/(6*79)) * A period time/1000

Dwell NVNT 1-DH1 2402MHz

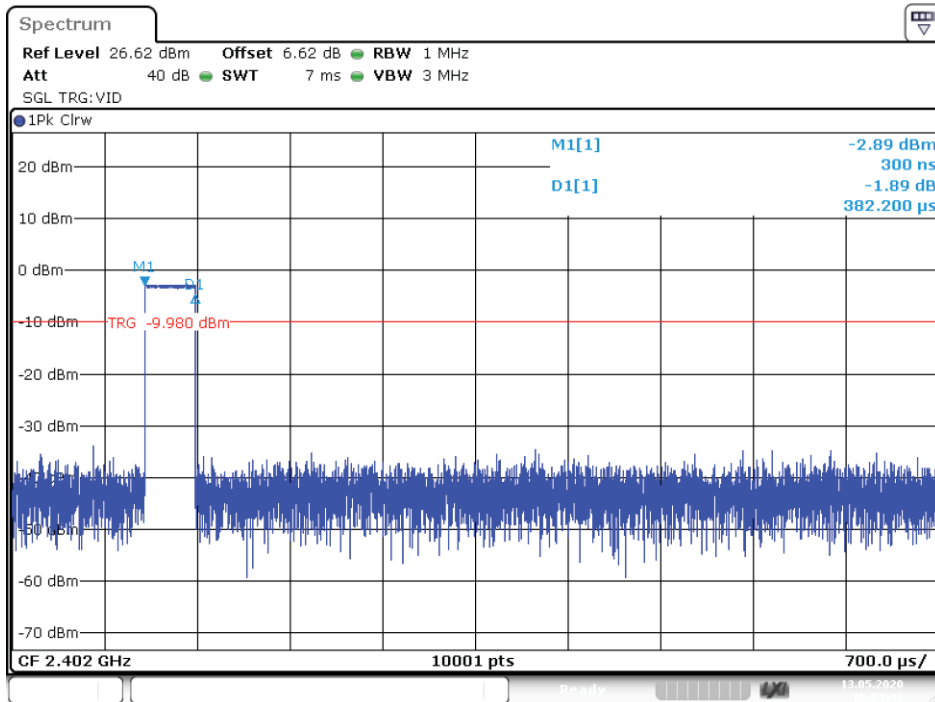

Date: 13.MAY.2020 10:03:42

Dwell NVNT 1-DH1 2441MHz

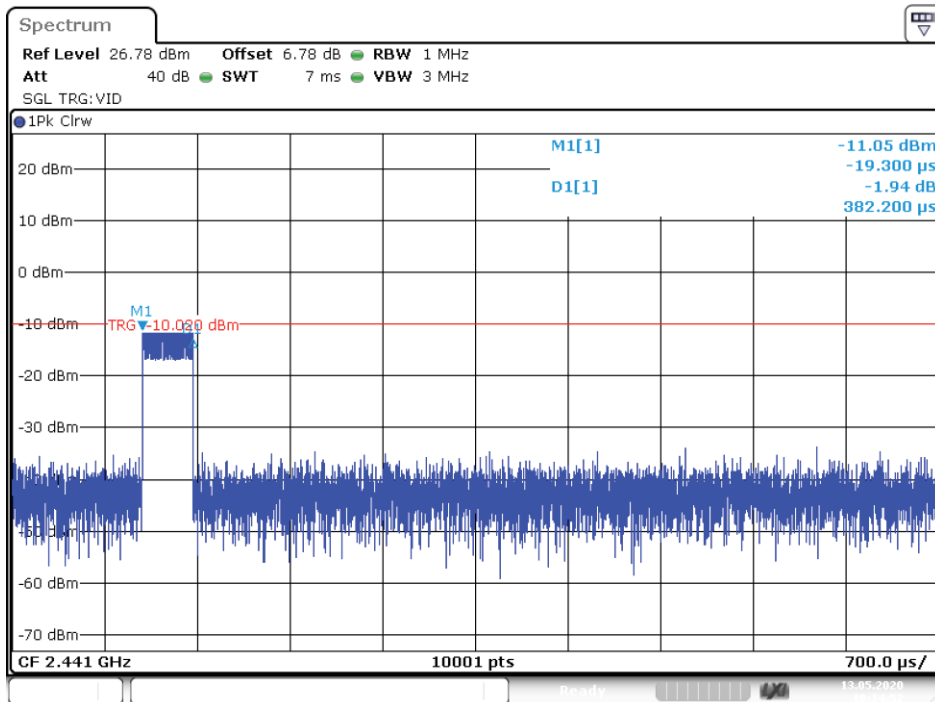

Date: 13.MAY.2020 10:14:52

Dwell NVNT 1-DH1 2480MHz

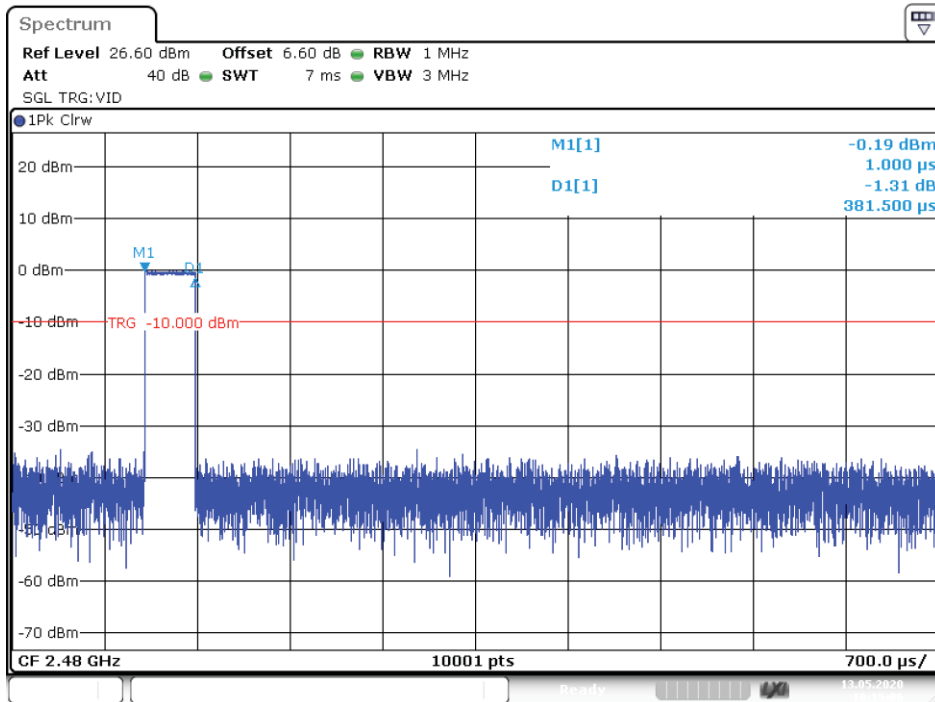

Date: 13.MAY.2020 10:15:05

Dwell NVNT 1-DH3 2441MHz

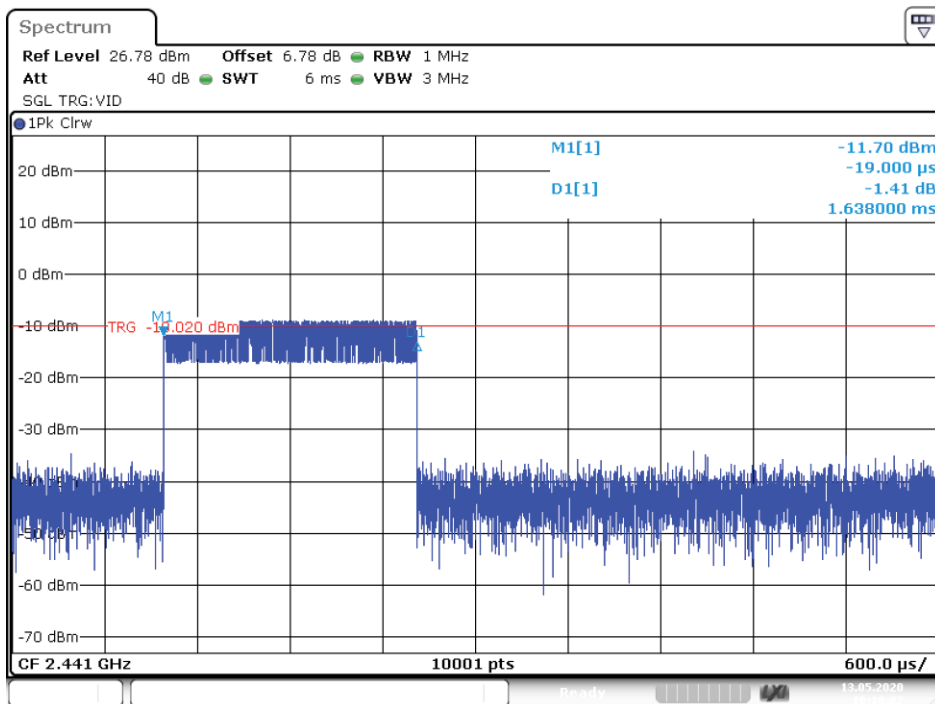

Date: 13.MAY.2020 10:18:02

Dwell NVNT 1-DH5 2441MHz

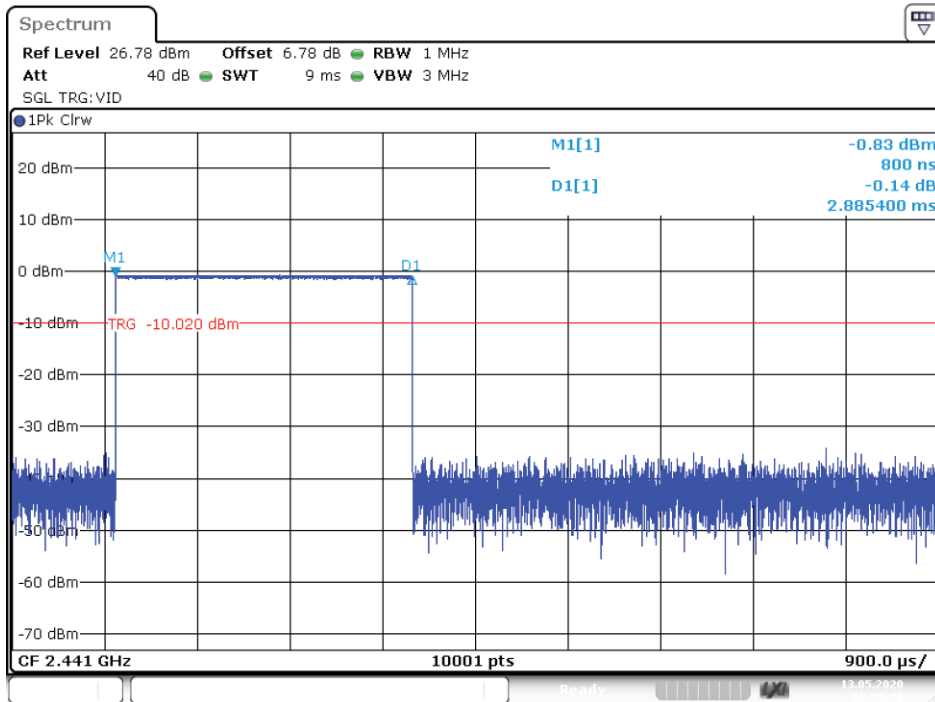

Date: 13.MAY.2020 10:19:21

Dwell NVNT 2-DH1 2402MHz

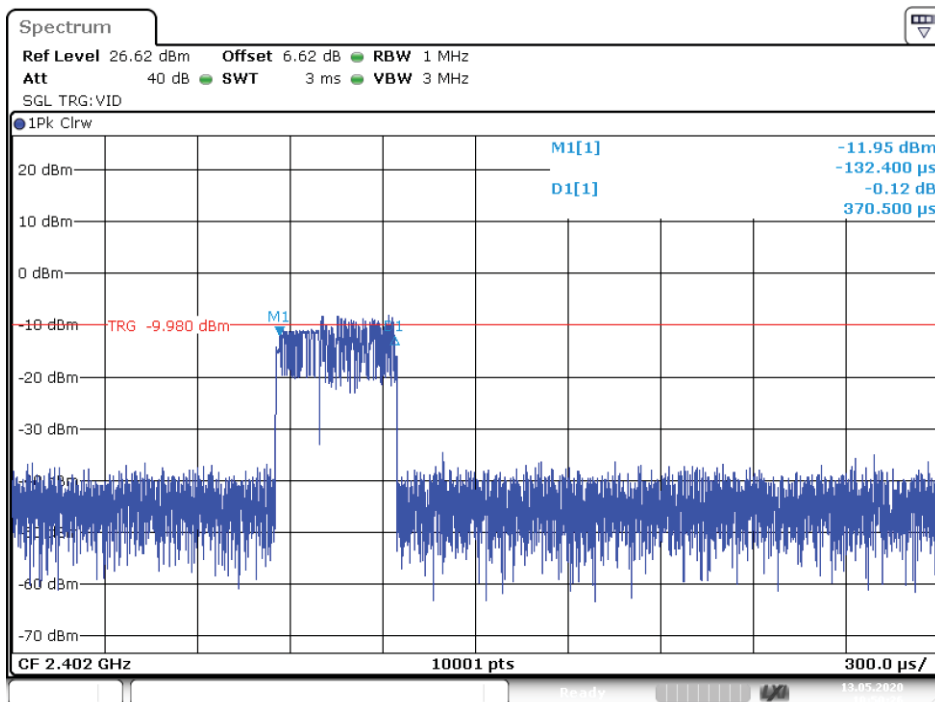

Date: 13.MAY.2020 10:50:25

Dwell NVNT 2-DH1 2441MHz

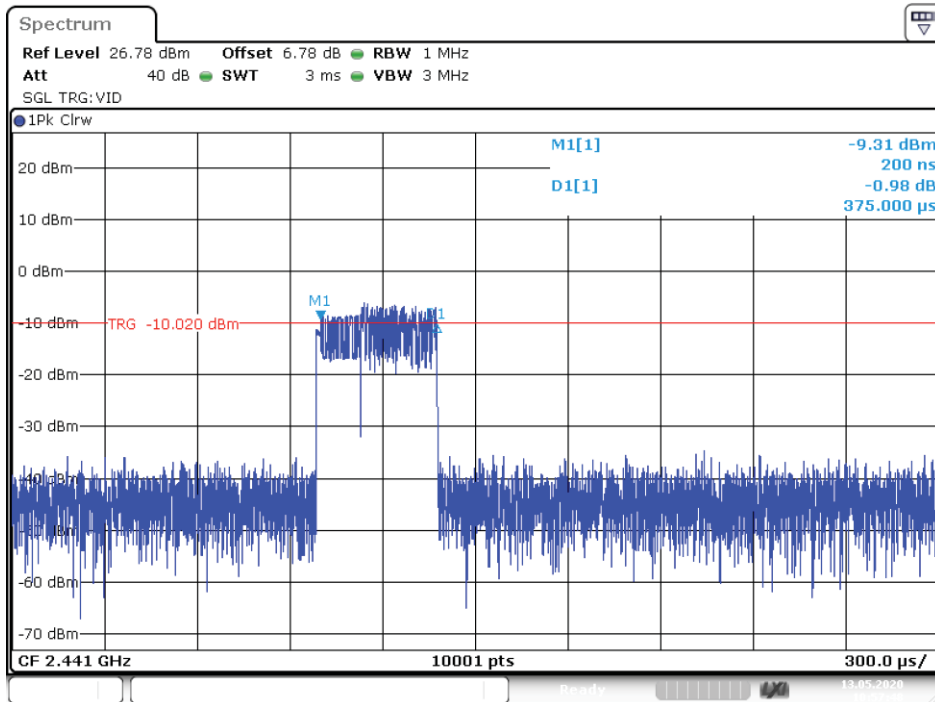

Date: 13.MAY.2020 10:57:49

Dwell NVNT 2-DH1 2460MHz

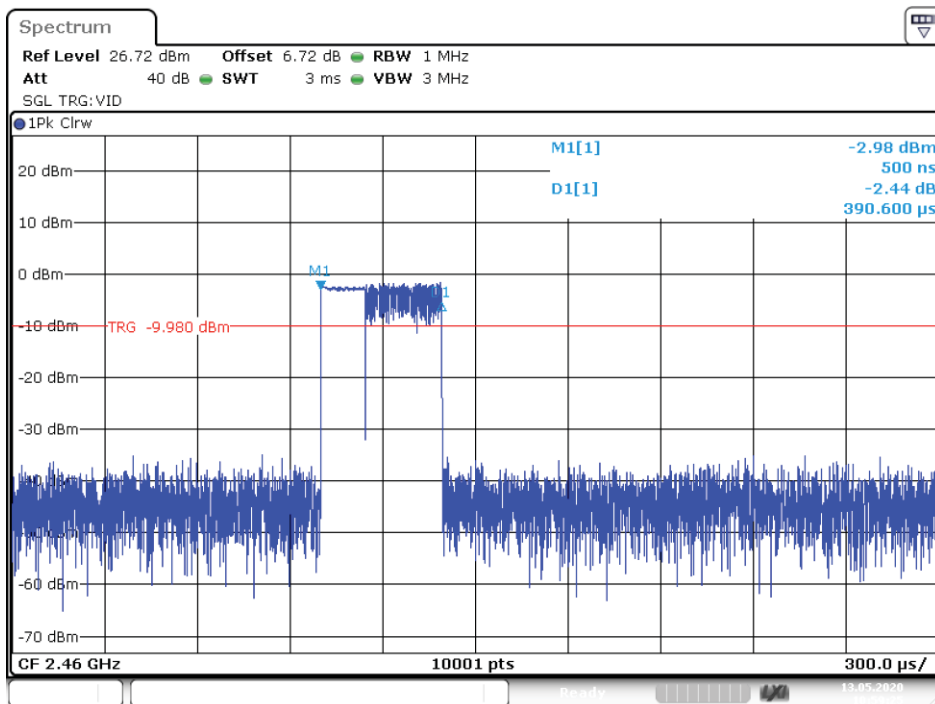

Date: 13.MAY.2020 10:59:26

Dwell NVNT 2-DH3 2441MHz

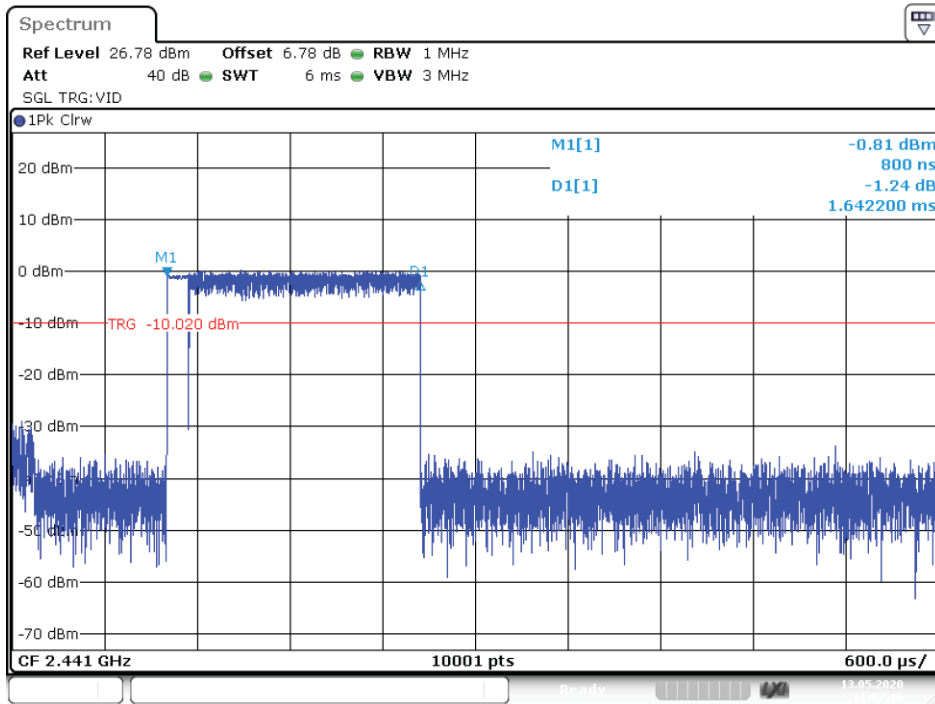

Date: 13.MAY.2020 11:07:16

Dwell NVNT 2-DH5 2441MHz

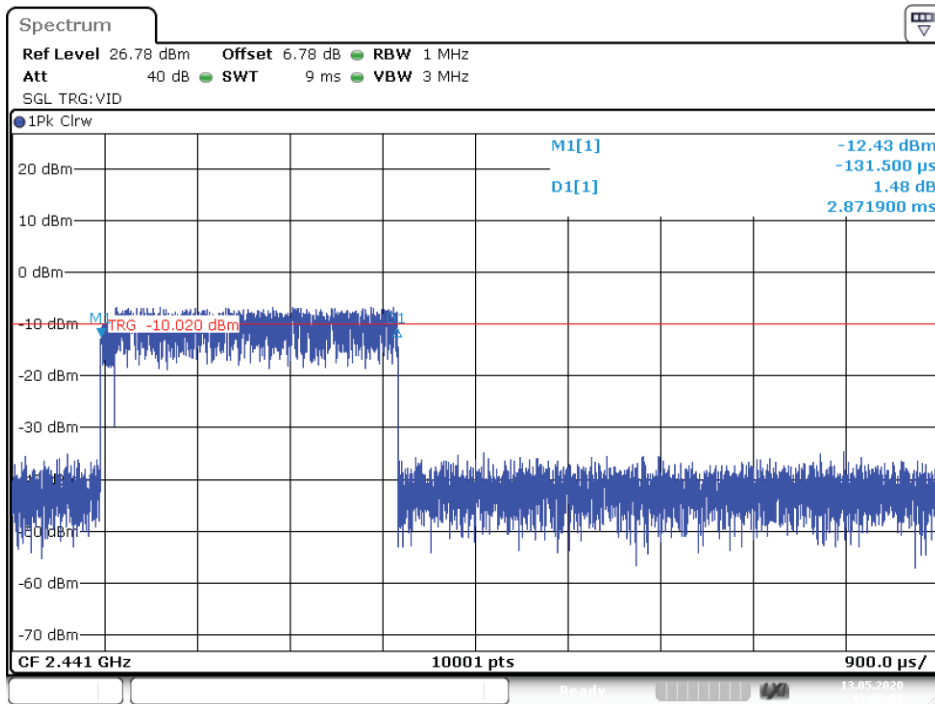

Date: 13.MAY.2020 11:08:01

Dwell NVNT 3-DH1 2402MHz

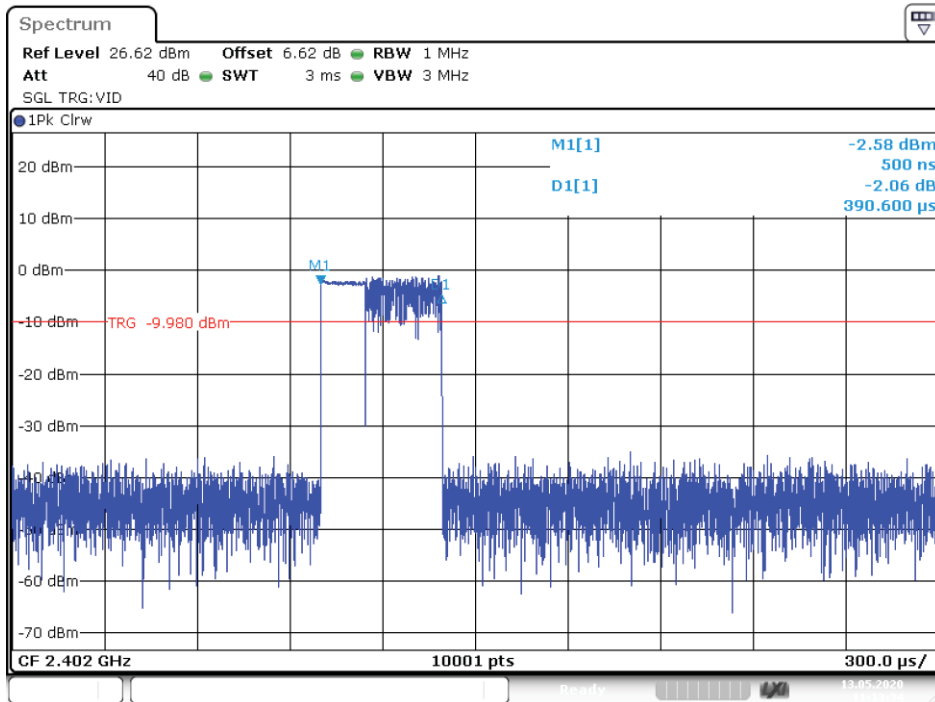

Date: 13.MAY.2020 11:13:34

Dwell NVNT 3-DH1 2441MHz

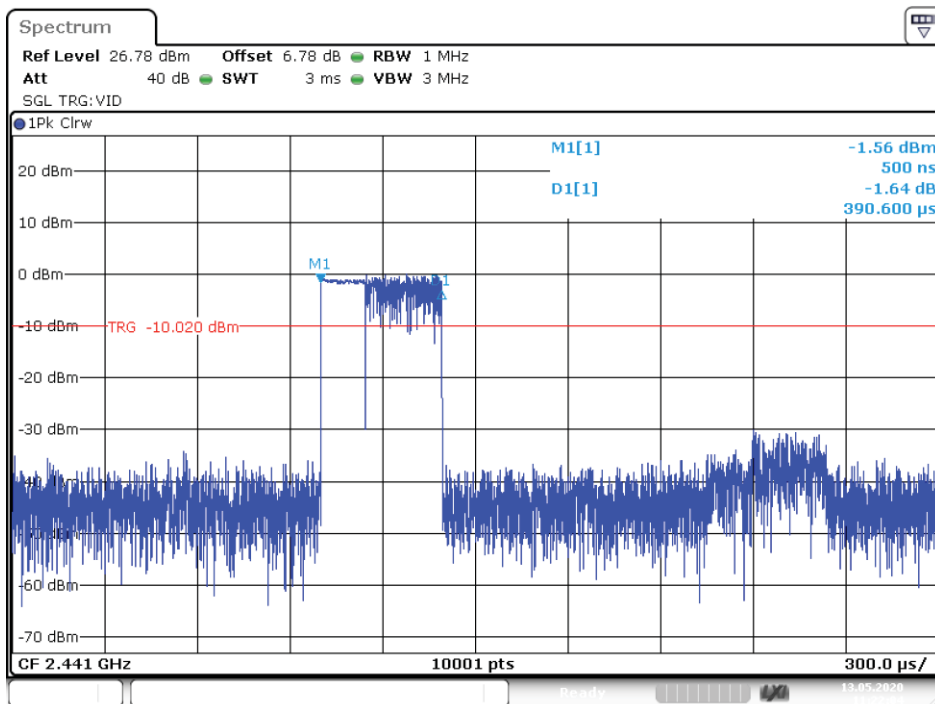

Date: 13.MAY.2020 11:22:04

Dwell NVNT 3-DH1 2480MHz

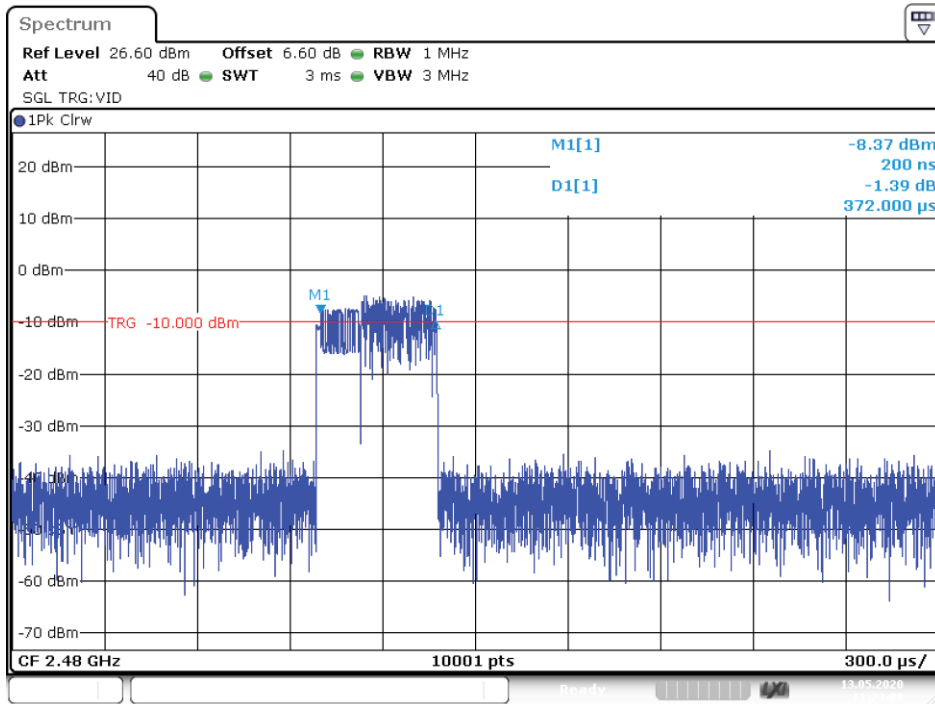

Date: 13.MAY.2020 11:23:08

Dwell NVNT 3-DH3 2441MHz

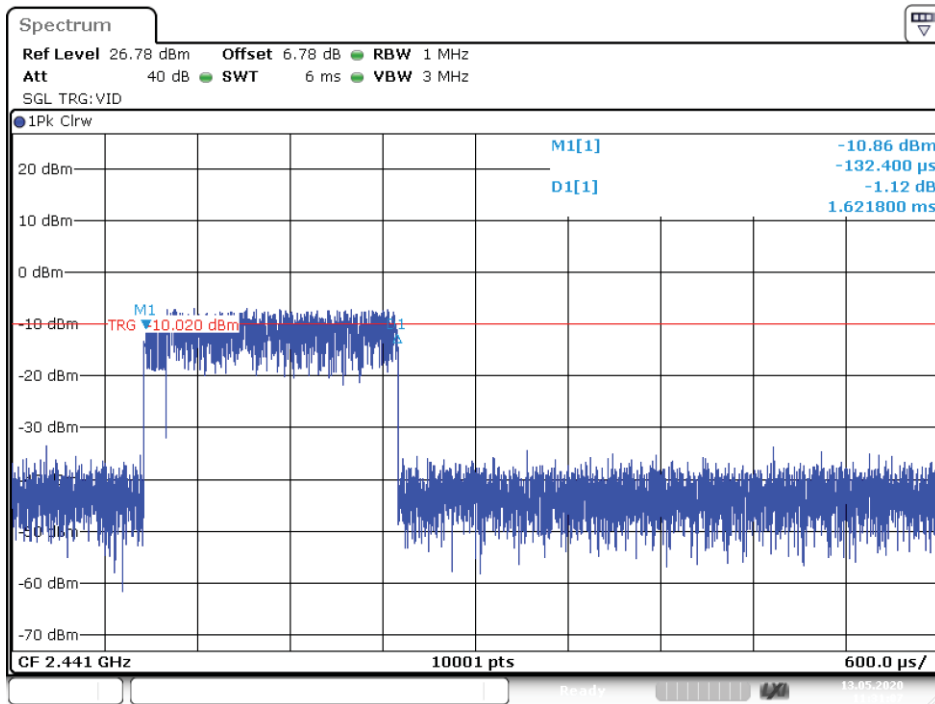

Date: 13.MAY.2020 11:31:07

Dwell NVNT 3-DH5 2441MHz

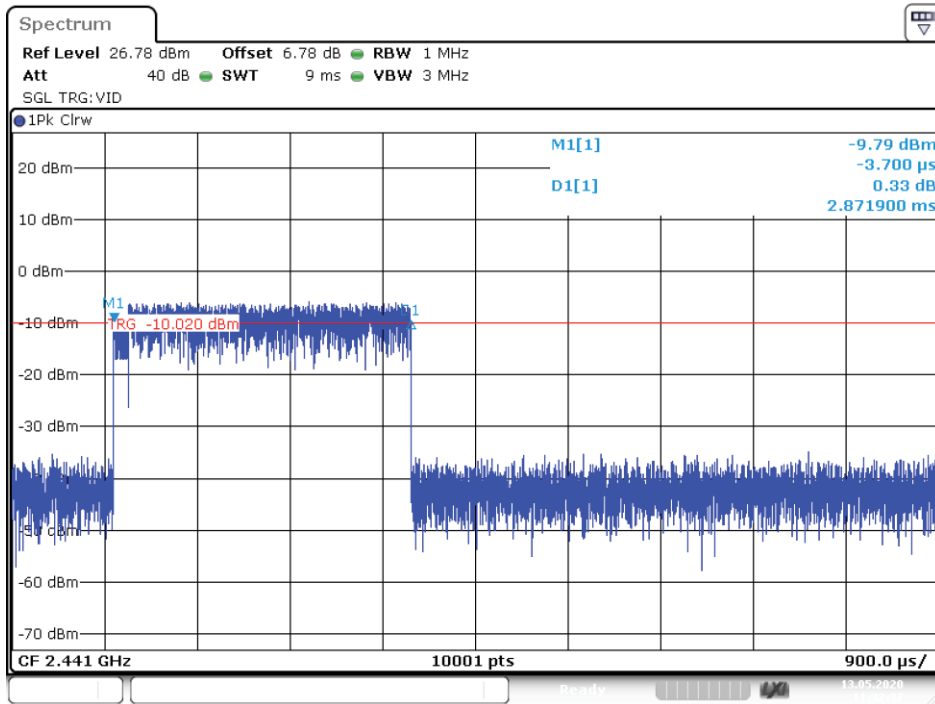

Date: 13.MAY.2020 11:32:37

8. RADIATED EMISSIONS

8.1.Limit

All the emissions appearing within 15.205 restricted frequency bands shall not exceed the limits shown in 15.209, all the other emissions shall be at least 20dB below the fundamental emissions, or comply with 15.209 limits.

15.205 Restricted frequency band

MHz	MHz	MHz	GHz
0.090 - 0.110	16.42 - 16.423	399.9 - 410	4.5 - 5.15
1.0495 - 0.505	16.69475 - 16.69525	608 - 614	5.35 - 5.46
2.1735 - 2.1905	16.80425 - 16.80475	960 - 1240	7.25 - 7.75
4.125 - 4.128	25.5 - 25.67	1300 - 1427	8.025 - 8.5
4.17725 - 4.17775	37.5 - 38.25	1435 - 1626.5	9.0 - 9.2
4.20725 - 4.20775	73 - 74.6	1645.5 - 1646.5	9.3 - 9.5
6.215 - 6.218	74.8 - 75.2	1660 - 1710	10.6 - 12.7
6.26775 - 6.26825	108 - 121.94	1718.8 - 1722.2	13.25 - 13.4
6.31175 - 6.31225	123 - 138	2200 - 2300	14.47 - 14.5
8.291 - 8.294	149.9 - 150.05	2310 - 2390	15.35 - 16.2
8.362 - 8.366	156.52475 - 156.52525	2483.5 - 2500	17.7 - 21.4
8.37625 - 8.38675	156.7 - 156.9	2690 - 2900	22.01 - 23.12
8.41425 - 8.41475	162.0125 - 167.17	3260 - 3267	23.6 - 24.0
12.29 - 12.293	167.72 - 173.2	3332 - 3339	31.2 - 31.8
12.51975 - 12.52025	240 - 285	3345.8 - 3358	36.43 - 36.5
12.57675 - 12.57725	322 - 335.4	3600 - 4400	(²)

15.209 Limit

FREQUENCY MHz	DISTANCE Meters	FIELD STRENGTHS LIMIT	
		$\mu\text{V}/\text{m}$	$\text{dB}(\mu\text{V})/\text{m}$
0.009-0.490	300	2400/F(KHz)	/
0.490-1.705	30	24000/F(KHz)	/
1.705-30	30	30	29.5
30 ~ 88	3	100	40.0
88 ~ 216	3	150	43.5
216 ~ 960	3	200	46.0
960 ~ 1000	3	500	54.0
Above 1000	3	74.0 dB(μV)/m (Peak) 54.0 dB(μV)/m (Average)	

8.2. Block Diagram of Test setup

8.2.1 In 3m Anechoic Chamber Test Setup Diagram for below 30MHz

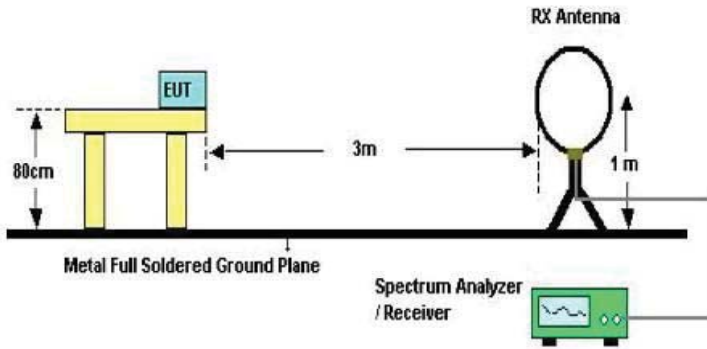

8.2.1 In 3m Anechoic Chamber Test Setup Diagram for below 1GHz

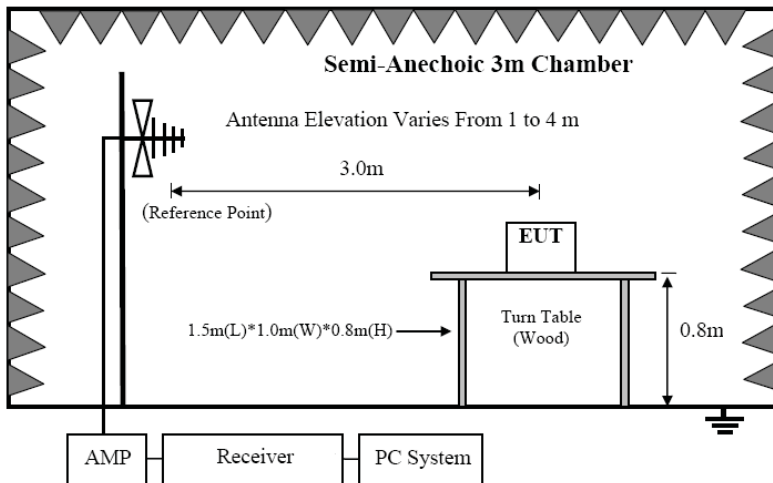

8.2.2 In 3m Anechoic Chamber Test Setup Diagram for frequency above 1GHz

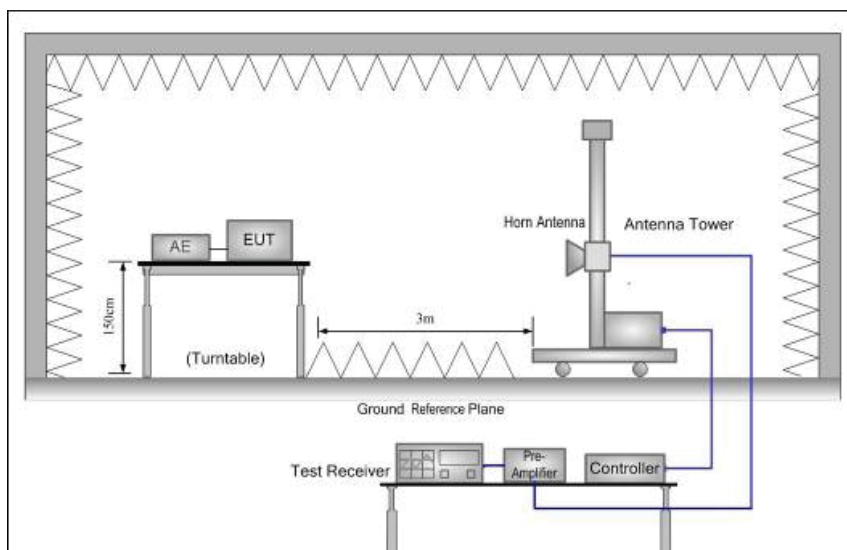

Note: For harmonic emissions test a appropriate high pass filter was inserted in the input port of AMP.

8.3. Test Procedure

- (1) EUT was placed on a non-metallic table, 80 cm above the ground plane inside a semi-anechoic chamber.
- (2) Setup EUT and simulator as shown in section 1.4 and 6.1
- (3) Test antenna was located 3m from the EUT on an adjustable mast. Below pre-scan procedure was first performed in order to find prominent radiated emissions.
 - (a) Change work frequency or channel of device if practicable.
 - (b) Change modulation type of device if practicable.
 - (c) Rotated EUT though three orthogonal axes to determine the attitude of EUT arrangement produces highest emissions
- (4) Spectrum frequency from 9KHz to 25GHz (tenth harmonic of fundamental frequency) was investigated
- (5) For final emissions measurements at each frequency of interest, the EUT were rotated and the antenna height was varied between 1m and 4m in order to maximize the emission. Measurements in both horizontal and vertical polarities were made and the data was recorded. In order to find the maximum emission, the relative positions of equipments and all of the interface cables were changed according to ANSI C63.10 :2013on Radiated Emission test.
- (6) For emissions above 1GHz, both Peak and Average level were measured with Spectrum Analyzer, and the RBW is set at 1MHz, VBW is set at 3MHz for Peak measure; RBW is set at 1MHz, VBW is set at 10Hz for Average measure.

8.4. Test Result

We have scanned the 10th harmonic from 9KHz to the EUT's highest frequency.. Detailed information please see the following page.

From 9KHz to 30MHz: Conclusion: PASS

Note: The amplitude of spurious emissions which are attenuated by more than 20dB below the permissible value has no need to be reported.

From 30MHz to 1000MHz: Conclusion: PASS

Pol Vertical

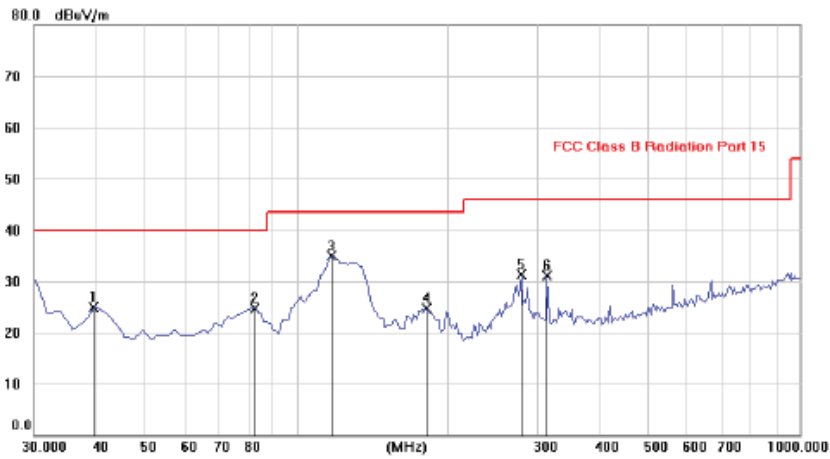

No.	Mk.	Freq.	Reading Level	Correct Factor	Measurement	Limit	Margin	Antenna Height	Table Degree	
		MHz	dBuV	dB	dBuV/m	dBuV/m	dB	cm	degree	Comment
1		39.7000	43.04	-18.10	24.94	40.00	-15.06			peak
2		82.3800	47.04	-22.35	24.69	40.00	-15.31			peak
3	*	117.3000	54.32	-19.37	34.95	43.50	-8.55			peak
4		181.3200	43.98	-19.29	24.69	43.50	-18.81			peak
5		280.2800	49.15	-17.86	31.29	46.00	-14.71			peak
6		315.1800	48.03	-16.83	31.20	46.00	-14.80			peak

Pol Horizontal

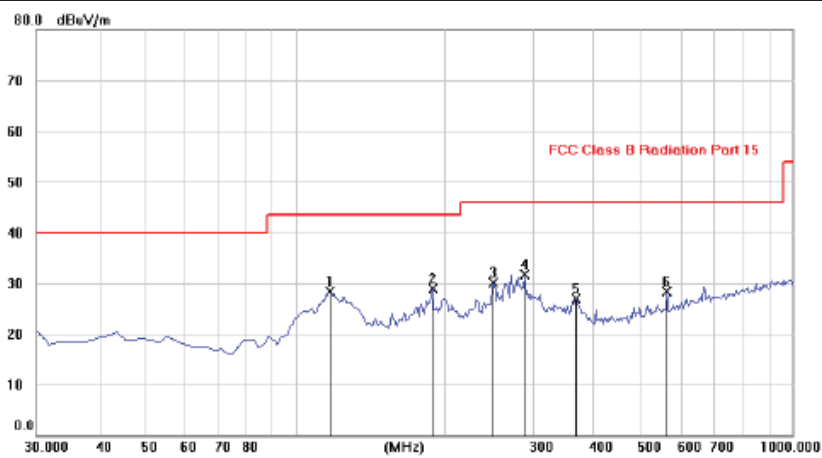

No.	Mk.	Freq.	Reading Level	Correct Factor	Measurement	Limit	Margin	Antenna Height	Table Degree	
		MHz	dBuV	dB	dBuV/m	dBuV/m	dB	cm	degree	Comment
1		117.3000	47.60	-19.37	28.23	43.50	-15.27			peak
2		189.0800	49.09	-20.20	28.89	43.50	-14.61			peak
3		251.1800	48.77	-18.76	30.01	46.00	-15.99			peak
4	*	289.9600	49.20	-17.53	31.67	46.00	-14.33			peak
5		367.5800	42.40	-15.54	26.86	46.00	-19.14			peak
6		559.6200	39.62	-11.34	28.28	46.00	-17.72			peak

*:Maximum data x:Over limit !:over margin

Note: Measurement=Reading Level+Correc Factor. Factor=(LISN or ISN or PLC or Current Probe)Factor+Cable

Remark: All modes have been tested, and only worst data of (GFSK) was listed in this report.

From 1G-25GHz

Test Mode: GFSK TX Low									
Freq (MHz)	Read Level (dBuV/m)	Polar (H/V)	Antenna Factor (dB/m)	Cable loss(dB)	Amp Factor (dB)	Result (dBuV/m)	Limit (dBuV/m)	Margin (dB)	Remark
4804	44.09	V	33.95	10.18	34.26	53.96	74	20.04	PK
4804	38.74	V	33.95	10.18	34.26	48.61	54	5.39	AV
7206	/	/	/	/	/	/	/	/	/
9608	/	/	/	/	/	/	/	/	/
4824	45.71	H	33.95	10.18	34.26	55.58	74	18.42	PK
4824	35.37	H	33.95	10.18	34.26	45.24	54	8.76	AV
7206	/	/	/	/	/	/	/	/	/
9608	/	/	/	/	/	/	/	/	/
Test Mode: GFSK TX Mid									
4882	44.72	V	33.93	10.2	34.29	54.56	74	19.44	PK
4882	35.98	V	33.93	10.2	34.29	45.82	54	8.18	AV
7323	/	/	/	/	/	/	/	/	/
9764	/	/	/	/	/	/	/	/	/
4882	45.80	H	33.93	10.2	34.29	55.64	74	18.36	PK
4882	34.36	H	33.93	10.2	34.29	44.20	54	9.80	AV
7323	/	/	/	/	/	/	/	/	/
9764	/	/	/	/	/	/	/	/	/
Test Mode: GFSK TX High									
4960	43.84	V	33.98	10.22	34.25	53.79	74	20.21	PK
4960	36.19	V	33.98	10.22	34.25	46.14	54	7.86	AV
7440	/	/	/	/	/	/	/	/	/
9920	/	/	/	/	/	/	/	/	/
4960	43.20	H	33.98	10.22	34.25	53.15	74	20.85	PK
4960	34.87	H	33.98	10.22	34.25	44.82	54	9.18	AV
7440	/	/	/	/	/	/	/	/	/
9920	/	/	/	/	/	/	/	/	/
Note:									
1, Result = Read level + Antenna factor + cable loss-Amp factor									
2, All the other emissions not reported were too low to read and deemed to comply with FCC limit.									

Remark: All modes have been tested, and only worst data of (GFSK) was listed in this report.

9. BAND EDGE COMPLIANCE

9.1. Block Diagram of Test Setup

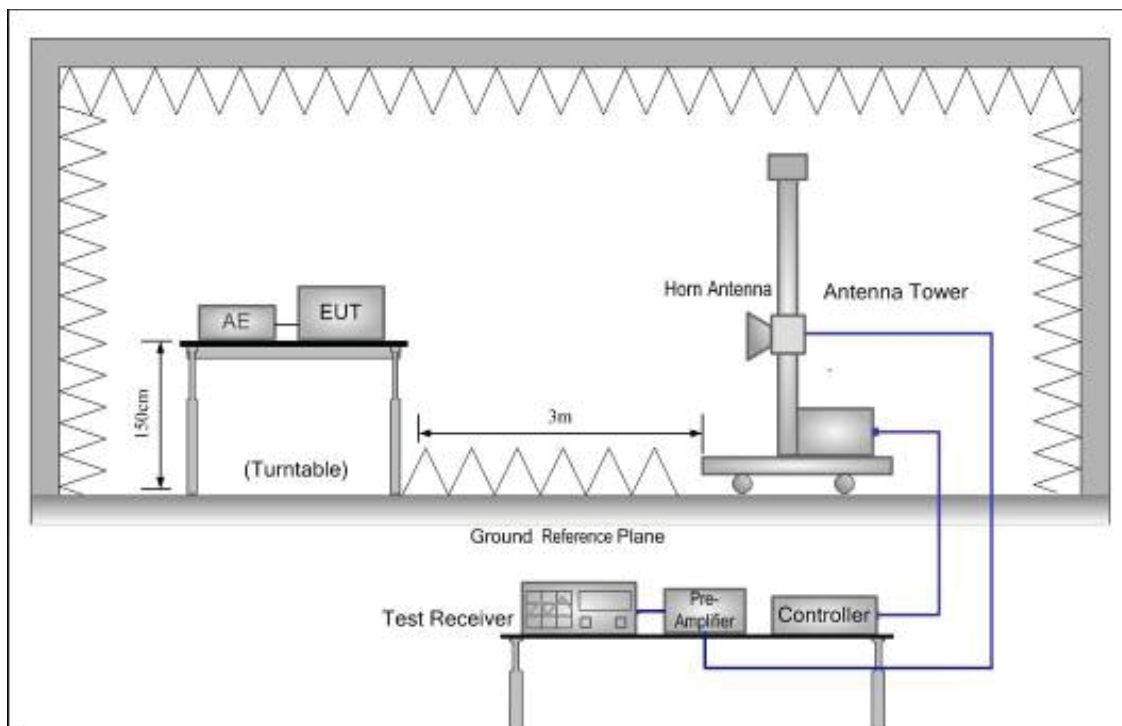

9.2. Limit

All the lower and upper band-edges emissions appearing within restricted frequency bands shall not exceed the limits shown in 15.209, all the other emissions outside operation shall be at least 20dB below the fundamental emissions, or comply with 15.209 limits.

9.3. Test Procedure

All restriction band and non- restriction band have been tested, only worse case is reported.

9.4. Test Result

PASS. (See below detailed test data)

Radiated Method:

Hopping-off

Polarization: Vertical

Test Mode:

GFSK-Low

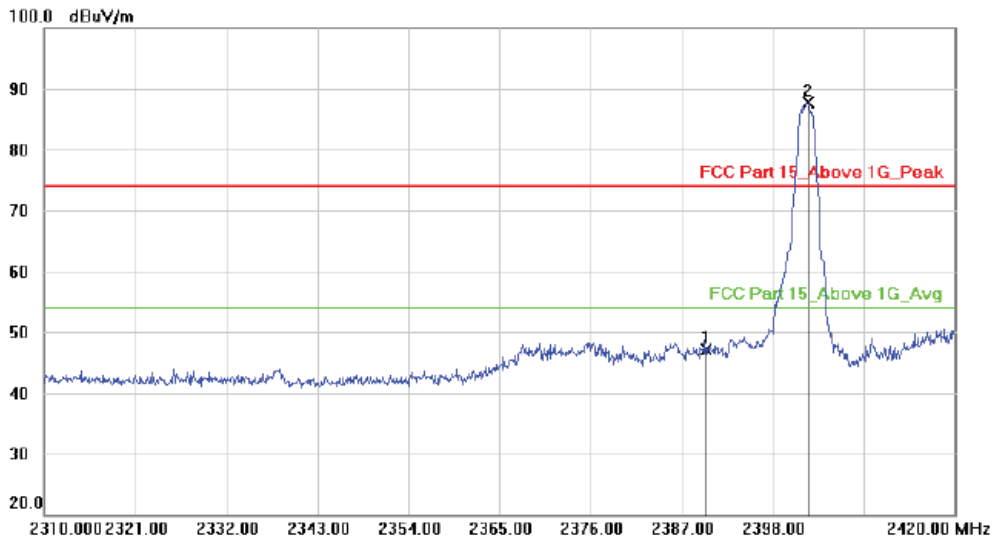

No.	Mk.	Freq.	Reading Level	Correct Factor	Measurement	Limit	Margin	Antenna Height	Table Degree	
		MHz	dBuV	dB	dBuV/m	dBuV/m	dB	cm	degree	Comment
1		2390.000	50.51	-3.40	47.11	74.00	-26.89			peak
2	*	2402.290	91.09	-3.41	87.68	74.00	13.68			peak

Polarization: Horizontal

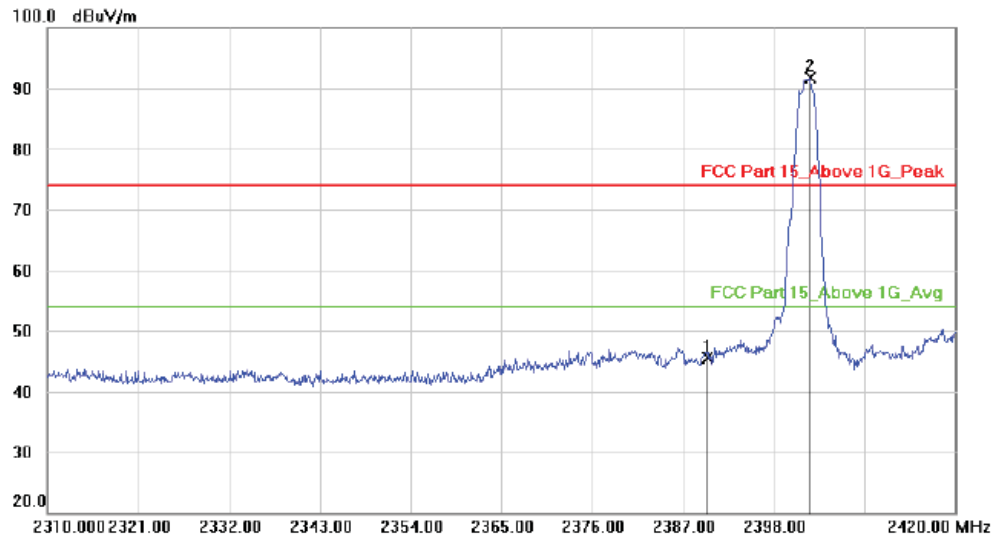

No.	Mk.	Freq.	Reading Level	Correct Factor	Measurement	Limit	Margin	Antenna Height	Table Degree	
		MHz	dBuV	dB	dBuV/m	dBuV/m	dB	cm	degree	Comment
1		2390.000	48.95	-3.40	45.55	74.00	-28.45			peak
2	*	2402.400	95.14	-3.41	91.73	74.00	17.73			peak

Hopping-on

Polarization: Vertical

Test Mode: GFSK-Low

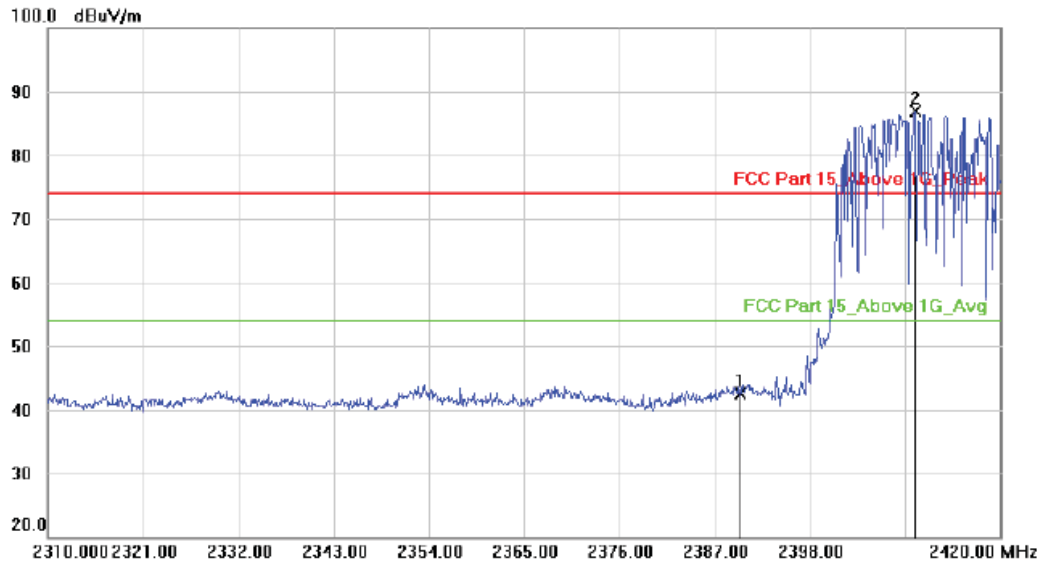

No.	Mk.	Freq.	Reading Level	Correct Factor	Measurement	Limit	Margin	Antenna Height	Table Degree	Comment
		MHz	dBuV	dB	dBuV/m	dBuV/m	dB	cm	degree	
1		2390.000	45.97	-3.40	42.57	74.00	-31.43			peak
2	*	2410.210	90.21	-3.40	86.81	74.00	12.81			peak

Polarization: Horizontal

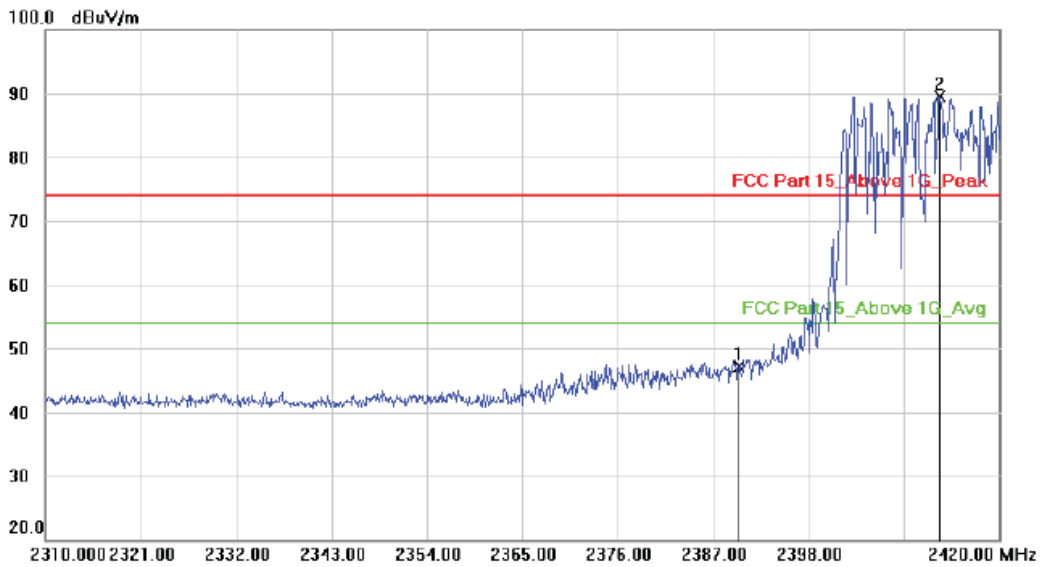

No.	Mk.	Freq.	Reading Level	Correct Factor	Measurement	Limit	Margin	Antenna Height	Table Degree	Comment
		MHz	dBuV	dB	dBuV/m	dBuV/m	dB	cm	degree	
1		2390.000	50.46	-3.40	47.06	74.00	-26.94			peak
2	*	2413.180	92.82	-3.41	89.41	74.00	15.41			peak

Hopping-off

Polarization: Vertical

Test Mode: GFSK-High

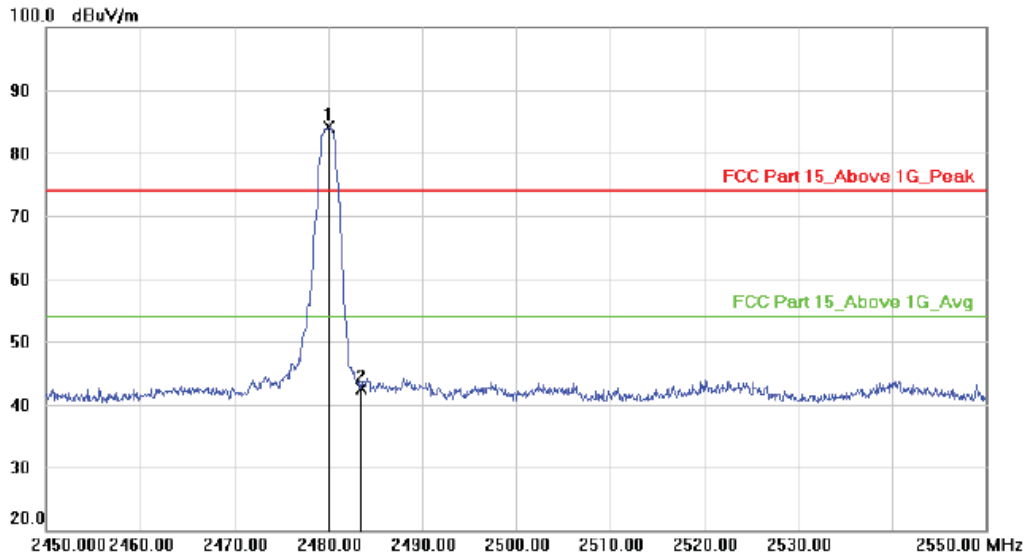

No.	Mk.	Freq.	Reading Level	Correct Factor	Measurement	Limit	Margin	Antenna Height	Table Degree	
		MHz	dBuV	dB	dBuV/m	dBuV/m	dB	cm	degree	Comment
1	*	2480.000	87.53	-3.38	84.15	74.00	10.15			peak
2		2483.500	45.86	-3.38	42.48	74.00	-31.52			peak

Polarization: Horizontal

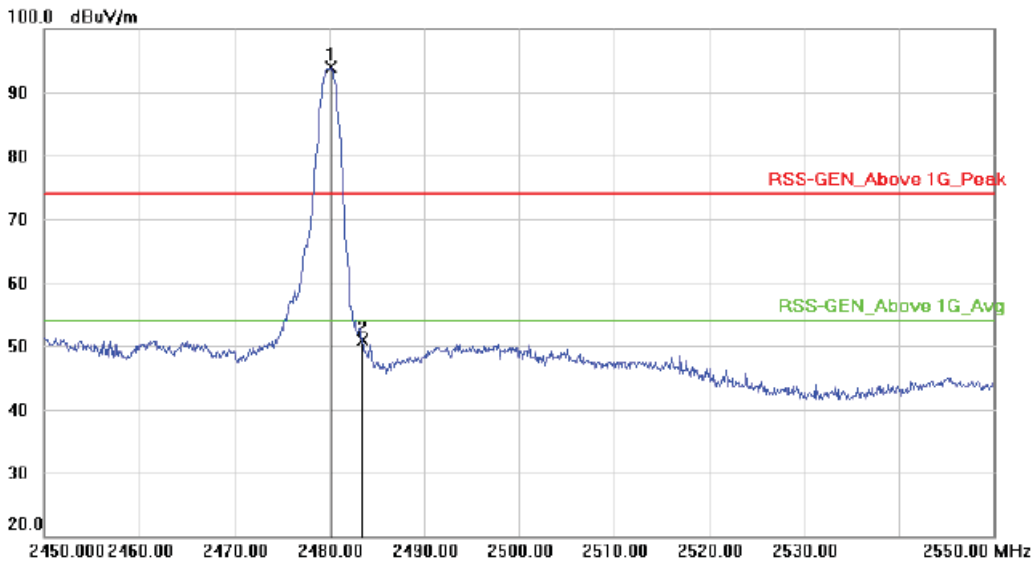

No.	Mk.	Freq.	Reading Level	Correct Factor	Measurement	Limit	Margin	Antenna Height	Table Degree	
		MHz	dBuV	dB	dBuV/m	dBuV/m	dB	cm	degree	Comment
1	*	2480.200	97.25	-3.38	93.87	74.00	19.87			peak
2		2483.500	54.32	-3.38	50.94	74.00	-23.06			peak

Hopping-on

Polarization: Vertical

Test Mode: GFSK-High

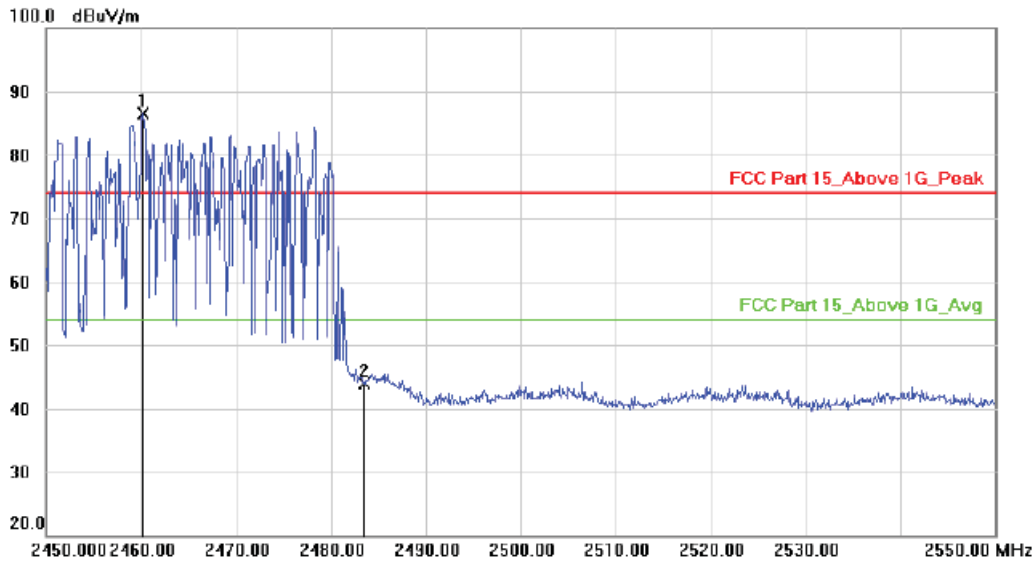

No.	Mk.	Freq.	Reading Level	Correct Factor	Measurement	Limit	Margin	Antenna Height	Table Degree	
		MHz	dBuV	dB	dBuV/m	dBuV/m	dB	cm	degree	Comment
1	*	2460.200	89.89	-3.39	86.50	74.00	12.50			peak
2		2483.500	47.26	-3.38	43.88	74.00	-30.12			peak

Polarization: Horizontal

Test Mode:

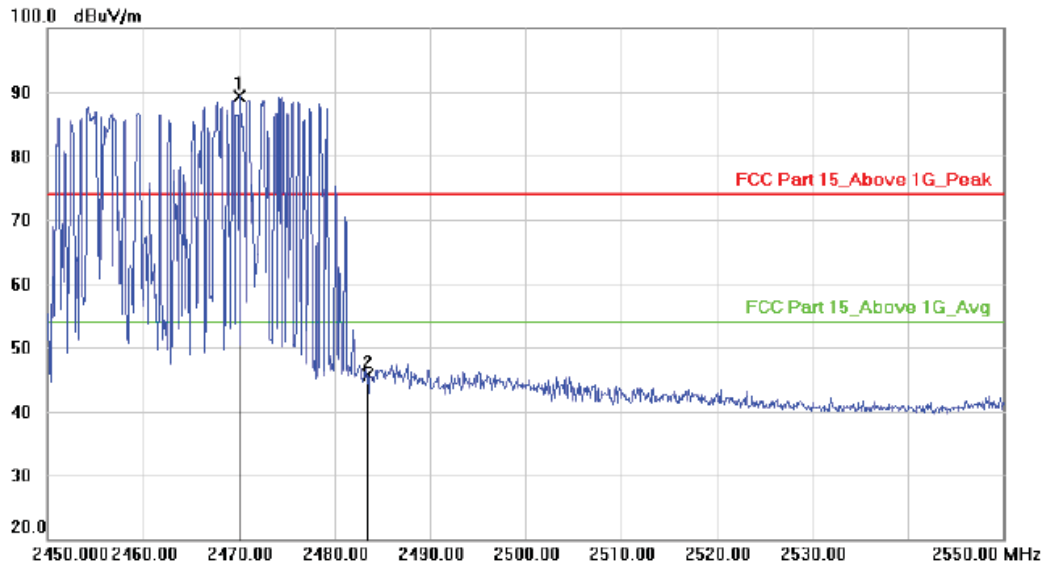

No.	Mk.	Freq.	Reading Level	Correct Factor	Measurement	Limit	Margin	Antenna Height	Table Degree	
		MHz	dBuV	dB	dBuV/m	dBuV/m	dB	cm	degree	Comment
1	*	2470.100	92.75	-3.39	89.36	74.00	15.36			peak
2		2483.500	49.17	-3.38	45.79	74.00	-28.21			peak

hopping-on

Hopping-off

Polarization: Vertical

Test Mode: π /4-DQPSK-Low

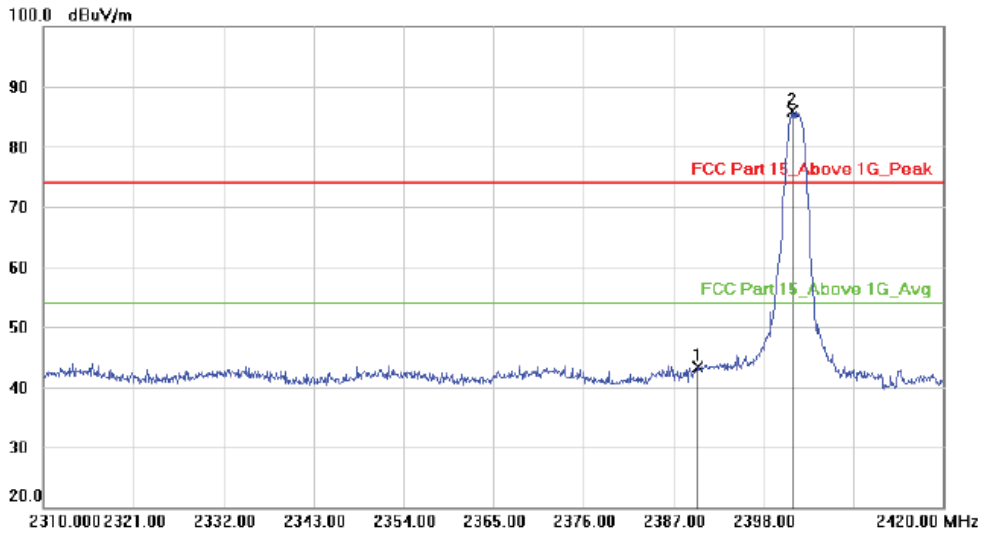

No.	Mk.	Freq.	Reading Level	Correct Factor	Measurement	Limit	Margin	Antenna Height	Table Degree
		MHz	dBuV	dB	dBuV/m	dBuV/m	dB	cm	degree
1		2390.000	46.61	-3.40	43.21	74.00	-30.79	peak	
2	*	2401.630	89.24	-3.41	85.83	74.00	11.83	peak	

Polarization: Horizontal

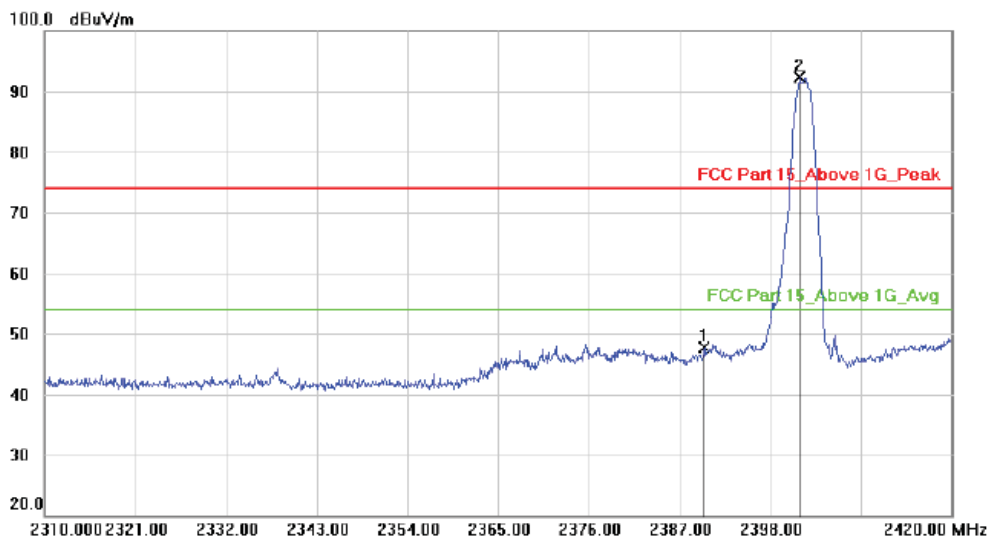

No.	Mk.	Freq.	Reading Level	Correct Factor	Measurement	Limit	Margin	Antenna Height	Table Degree
		MHz	dBuV	dB	dBuV/m	dBuV/m	dB	cm	degree
1		2390.000	51.18	-3.40	47.78	74.00	-26.22	peak	
2	*	2401.630	95.77	-3.41	92.36	74.00	18.36	peak	

Hopping-on

Polarization: Vertical

Test Mode: $\pi/4$ -DQPSK-Low

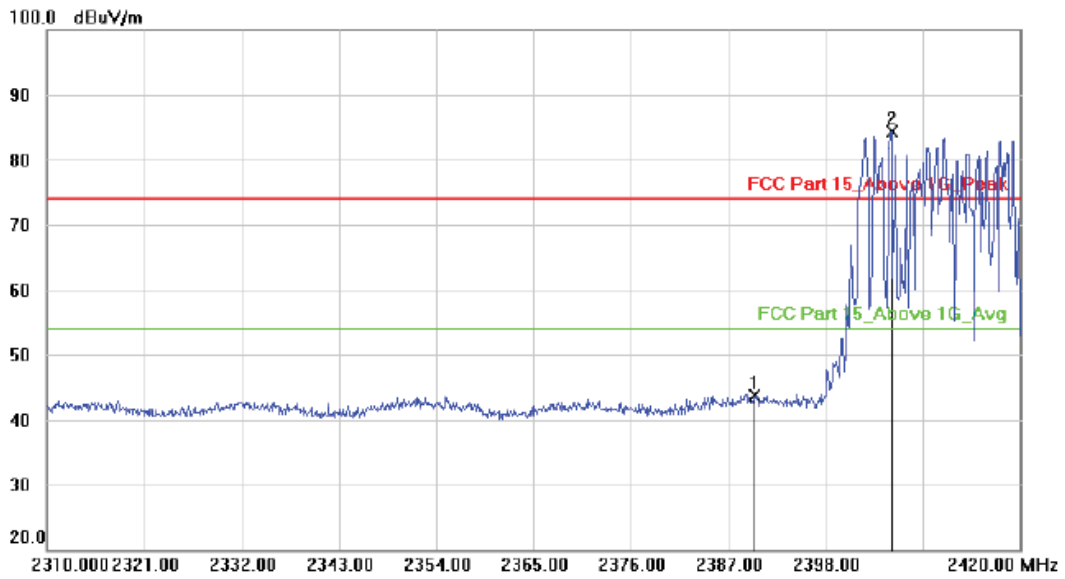

No.	Mk.	Freq. MHz	Reading Level dBuV	Correct Factor dB	Measure- ment dBuV/m	Limit dBuV/m	Margin dB	Antenna Height cm	Table Degree degree	Comment
1		2390.000	47.07	-3.40	43.67	74.00	-30.33			peak
2	*	2405.480	87.72	-3.41	84.31	74.00	10.31			peak

Polarization: Horizontal

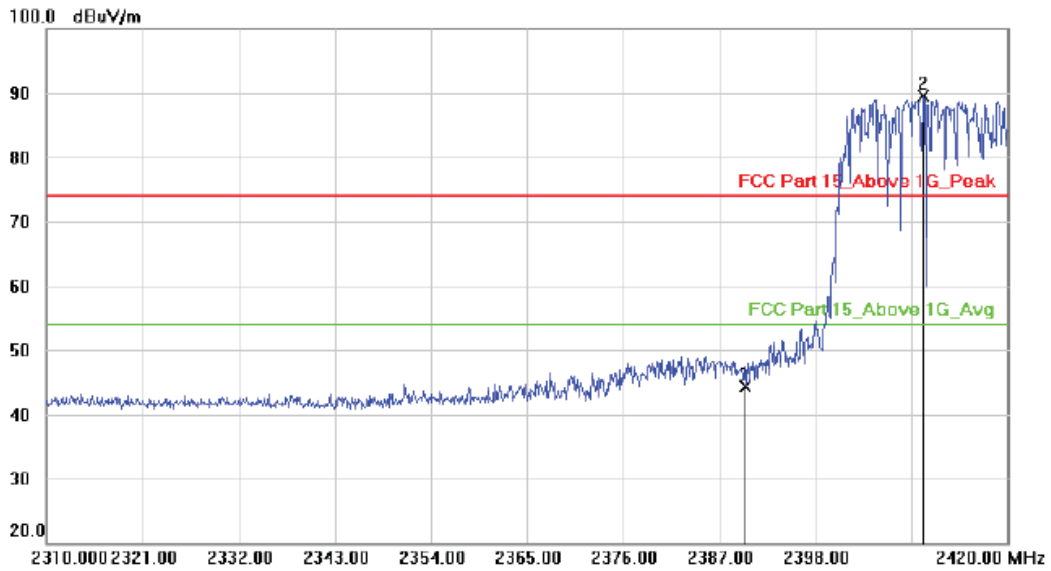

No.	Mk.	Freq. MHz	Reading Level dBuV	Correct Factor dB	Measure- ment dBuV/m	Limit dBuV/m	Margin dB	Antenna Height cm	Table Degree degree	Comment
1		2390.000	47.79	-3.40	44.39	74.00	-29.61			peak
2	*	2410.320	92.86	-3.40	89.46	74.00	15.46			peak

Hopping-off

Polarization: Vertical

Test Mode: $\pi/4$ -DQPSK-High

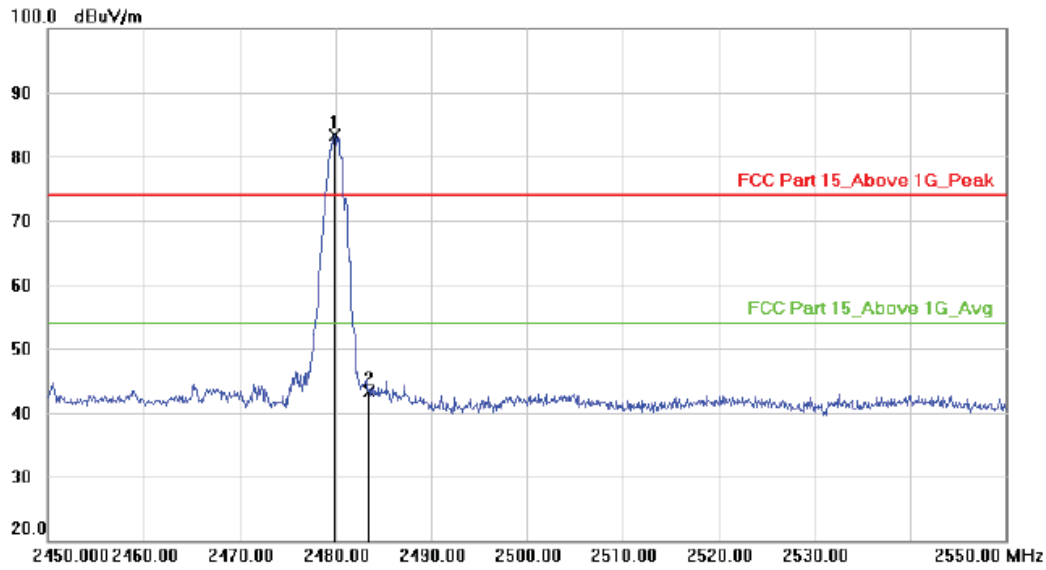

No.	Mk.	Freq.	Reading Level	Correct Factor	Measurement	Limit	Margin	Antenna Height	Table Degree
		MHz	dBuV	dB	dBuV/m	dBuV/m	dB	cm	degree
1	*	2479.900	86.69	-3.38	83.31	74.00	9.31		peak
2		2483.500	46.71	-3.38	43.33	74.00	-30.67		peak

Polarization: Horizontal

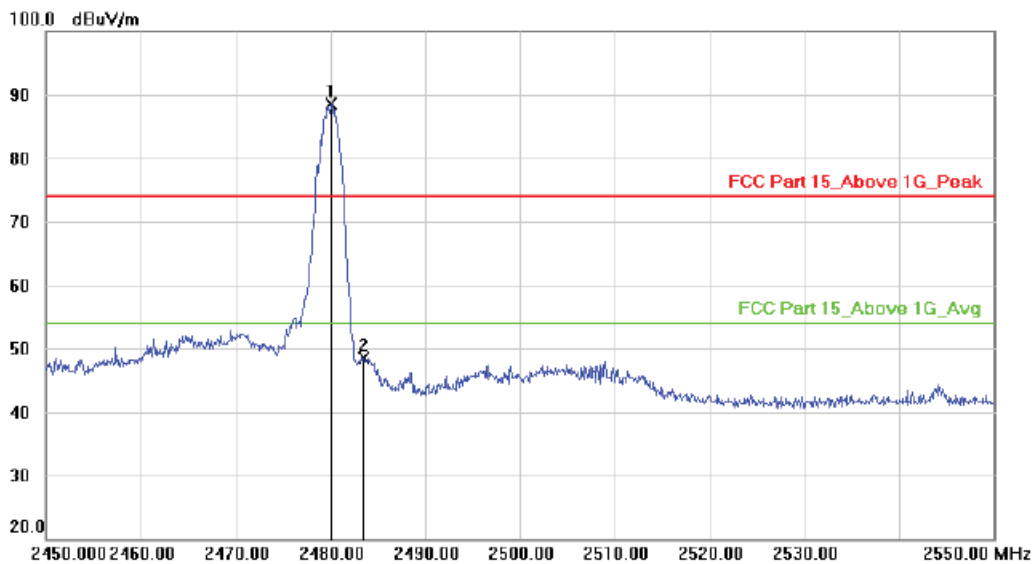

No.	Mk.	Freq.	Reading Level	Correct Factor	Measurement	Limit	Margin	Antenna Height	Table Degree
		MHz	dBuV	dB	dBuV/m	dBuV/m	dB	cm	degree
1	*	2480.000	91.82	-3.38	88.44	74.00	14.44		peak
2		2483.500	51.86	-3.38	48.48	74.00	-25.52		peak

Hopping-on

Polarization: Vertical

Test Mode: π /4-DQPSK-High

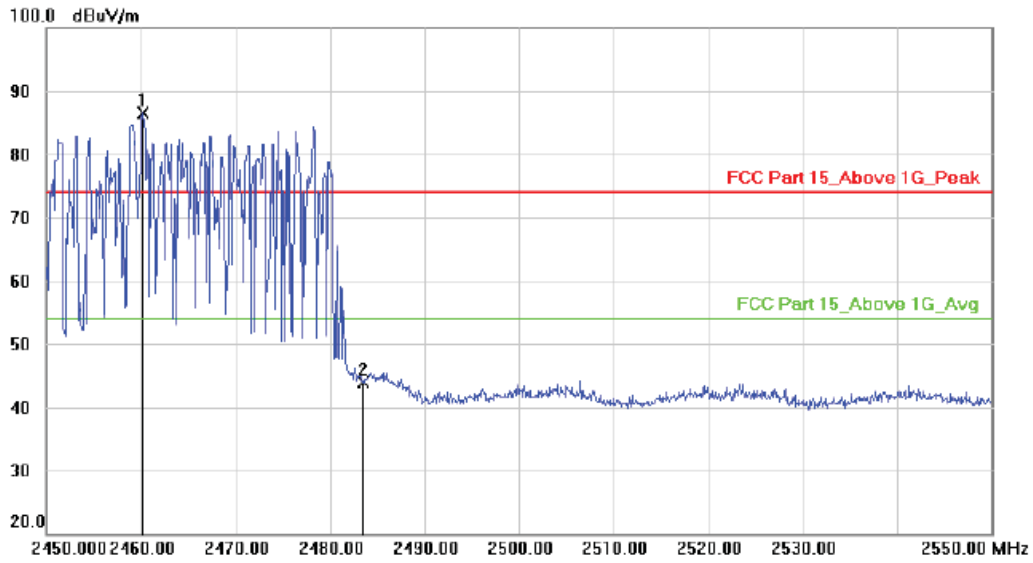

No.	Mk.	Freq.	Reading Level	Correct Factor	Measurement	Limit	Margin	Antenna Height	Table Degree	
		MHz	dBuV	dB	dBuV/m	dBuV/m	dB	cm	degree	Comment
1	*	2460.200	89.89	-3.39	86.50	74.00	12.50			peak
2		2483.500	47.26	-3.38	43.88	74.00	-30.12			peak

Polarization: Horizontal

Test Mode:

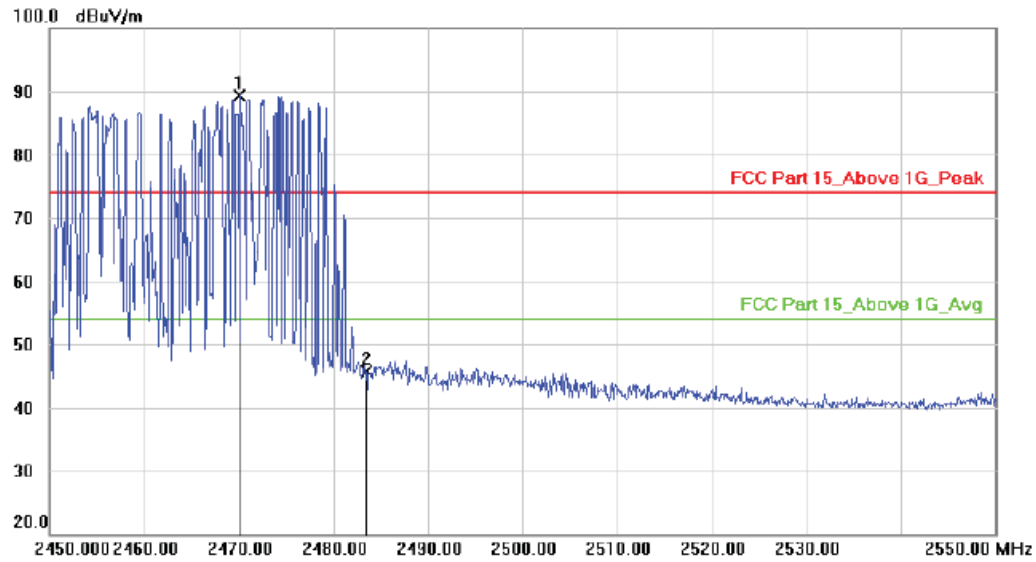

No.	Mk.	Freq.	Reading Level	Correct Factor	Measurement	Limit	Margin	Antenna Height	Table Degree	
		MHz	dBuV	dB	dBuV/m	dBuV/m	dB	cm	degree	Comment
1	*	2470.100	92.75	-3.39	89.36	74.00	15.36			peak
2		2483.500	49.17	-3.38	45.79	74.00	-28.21			peak

hopping-on

Hopping-off

Polarization: Vertical

Test Mode: 8-DPSK-Low

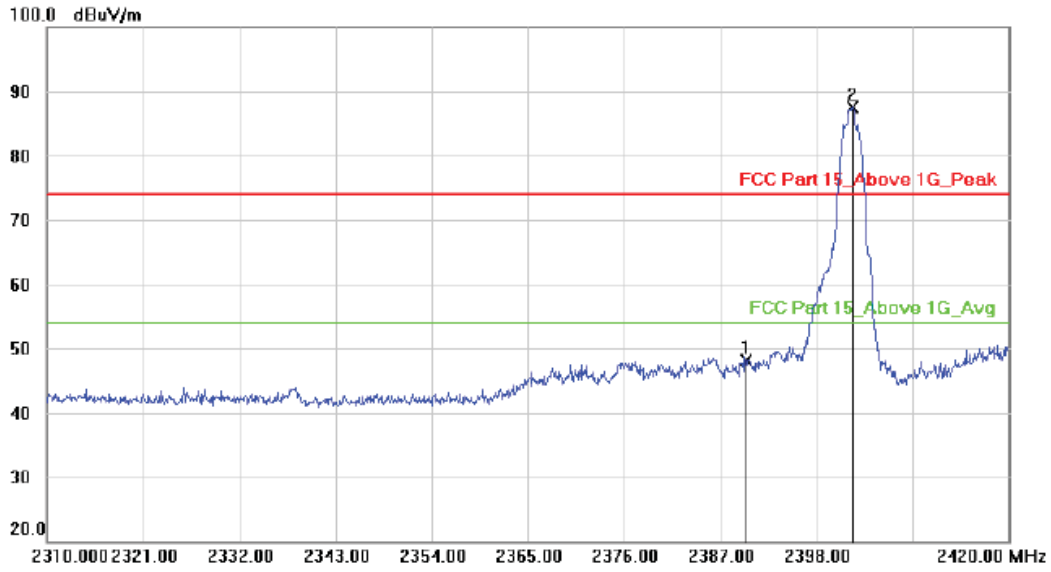

No.	Mk.	Freq.	Reading Level	Correct Factor	Measurement	Limit	Margin	Antenna Height	Table Degree	
		MHz	dBuV	dB	dBuV/m	dBuV/m	dB	cm	degree	Comment
1		2390.000	51.51	-3.40	48.11	74.00	-25.89			peak
2	*	2402.180	91.01	-3.41	87.60	74.00	13.60			peak

Polarization: Horizontal

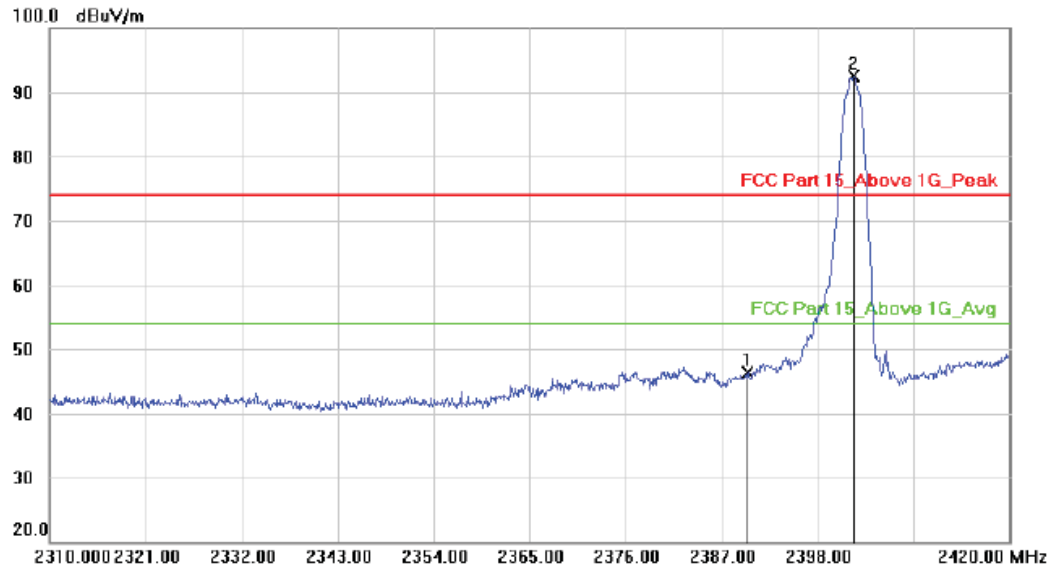

No.	Mk.	Freq.	Reading Level	Correct Factor	Measurement	Limit	Margin	Antenna Height	Table Degree	
		MHz	dBuV	dB	dBuV/m	dBuV/m	dB	cm	degree	Comment
1		2390.000	49.68	-3.40	46.28	74.00	-27.72			peak
2	*	2402.180	95.92	-3.41	92.51	74.00	18.51			peak

Hopping-on

Polarization: Vertical

Test Mode: 8-DPSK -Low

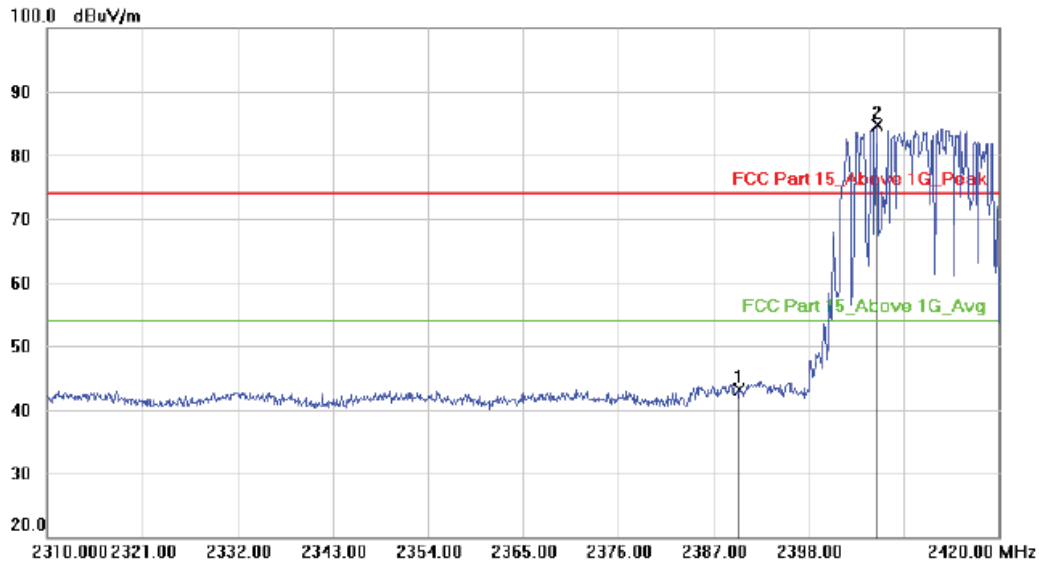

No.	Mk.	Freq.	Reading Level	Correct Factor	Measurement	Limit	Margin	Antenna Height	Table Degree	
		MHz	dBuV	dB	dBuV/m	dBuV/m	dB	cm	degree	Comment
1		2390.000	46.57	-3.40	43.17	74.00	-30.83			peak
2	*	2406.030	88.16	-3.41	84.75	74.00	10.75			peak

Polarization: Horizontal

Test Mode:

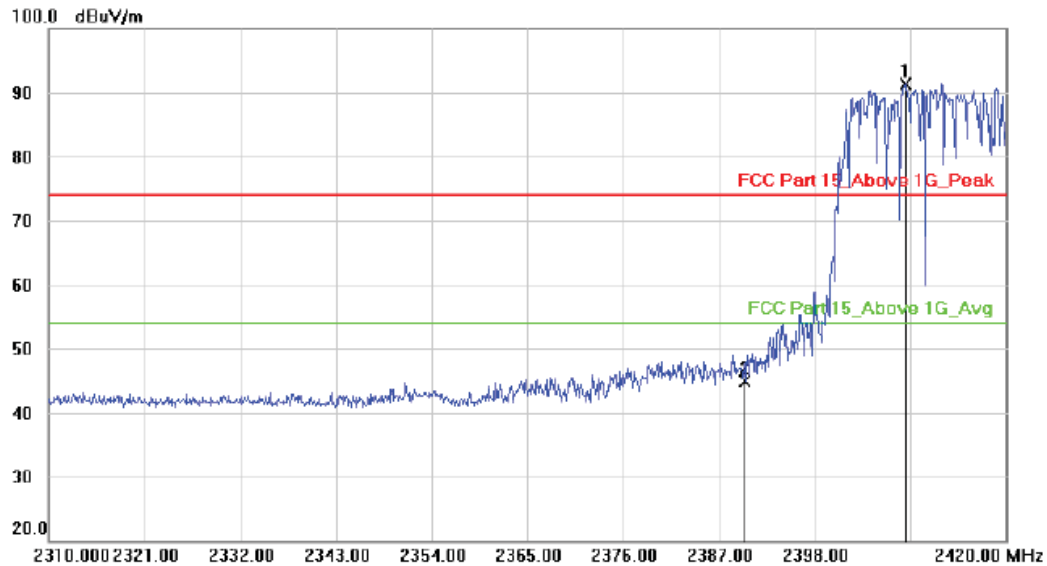

No.	Mk.	Freq.	Reading Level	Correct Factor	Measurement	Limit	Margin	Antenna Height	Table Degree	
		MHz	dBuV	dB	dBuV/m	dBuV/m	dB	cm	degree	Comment
1	*	2408.450	94.72	-3.40	91.32	74.00	17.32			peak
2		2390.000	48.29	-3.40	44.89	74.00	-29.11			peak

hopping-on

Hopping-off

Polarization: Vertical

Test Mode: 8-DPSK-High

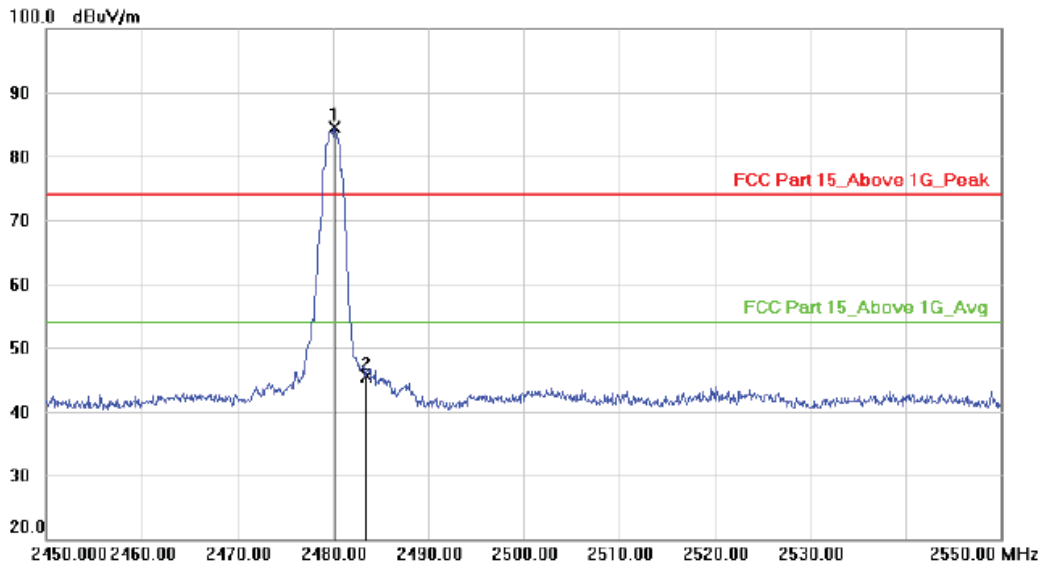

No.	Mk.	Freq.	Reading Level	Correct Factor	Measurement	Limit	Margin	Antenna Height	Table Degree
		MHz	dBuV	dB	dBuV/m	dBuV/m	dB	cm	degree
1	*	2480.200	87.90	-3.38	84.52	74.00	10.52	peak	
2		2483.500	48.86	-3.38	45.48	74.00	-28.52	peak	

Polarization: Horizontal

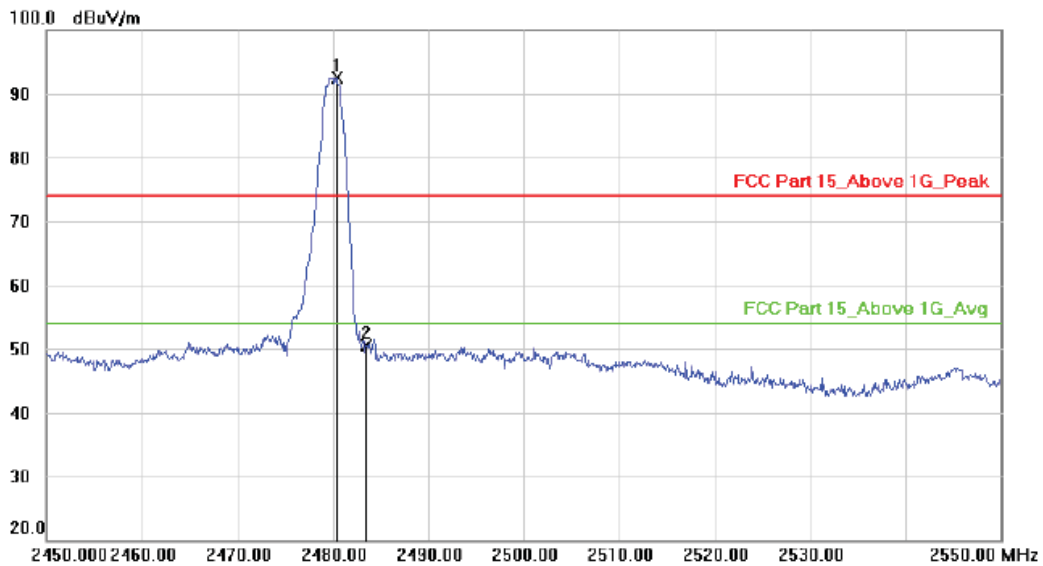

No.	Mk.	Freq.	Reading Level	Correct Factor	Measurement	Limit	Margin	Antenna Height	Table Degree
		MHz	dBuV	dB	dBuV/m	dBuV/m	dB	cm	degree
1	*	2480.400	95.94	-3.38	92.56	74.00	18.56	peak	
2		2483.500	53.82	-3.38	50.44	74.00	-23.56	peak	

Hopping-on

Polarization: Vertical

Test Mode: 8-DPSK -High

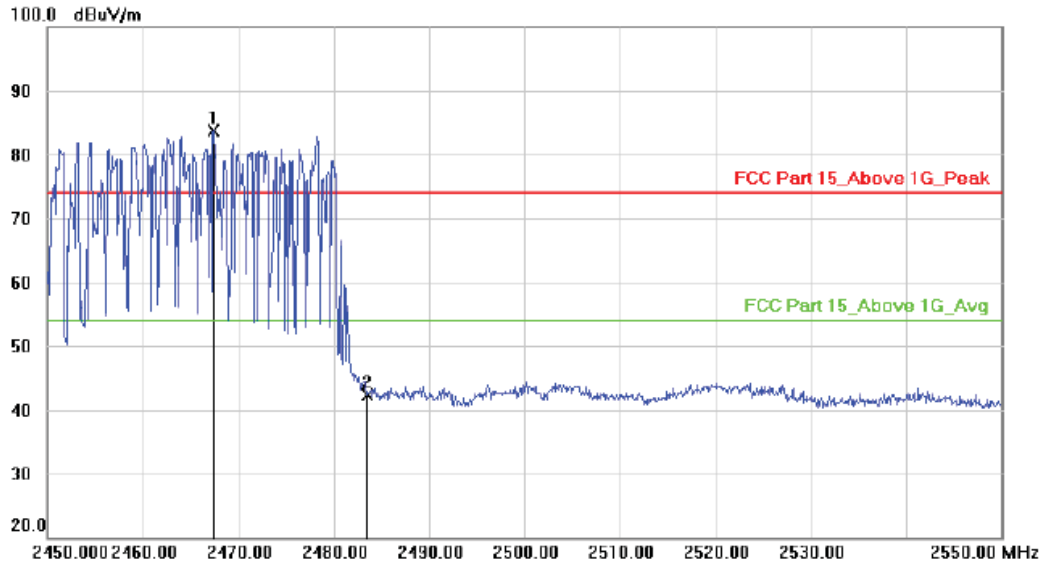

No.	Mk.	Freq.	Reading Level	Correct Factor	Measurement	Limit	Margin	Antenna Height	Table Degree
		MHz	dBuV	dB	dBuV/m	dBuV/m	dB	cm	degree
1	*	2467.400	87.09	-3.39	83.70	74.00	9.70	peak	
2		2483.500	45.76	-3.38	42.38	74.00	-31.62	peak	

Polarization: Horizontal

Test Mode:

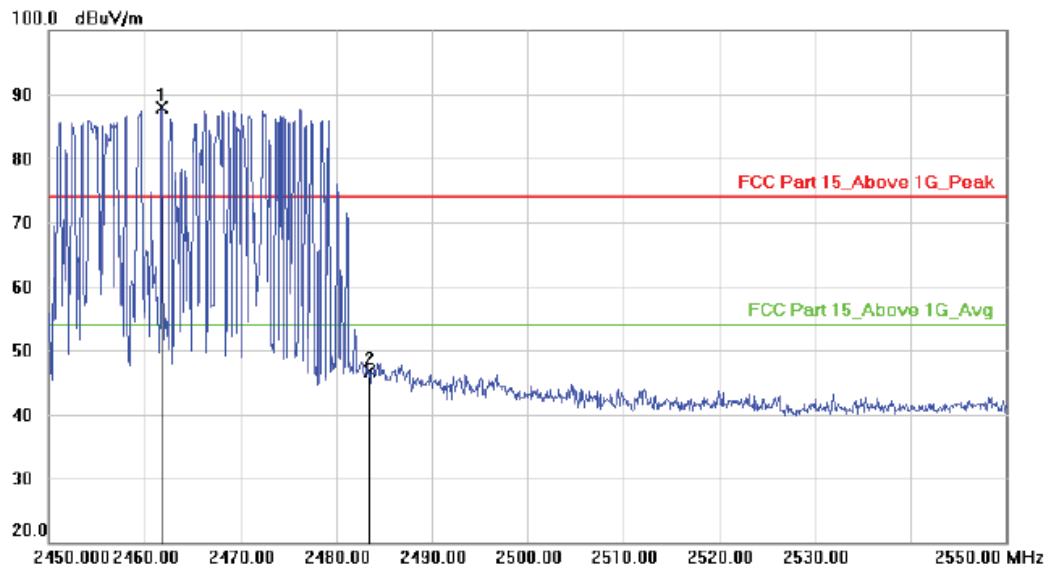

No.	Mk.	Freq.	Reading Level	Correct Factor	Measurement	Limit	Margin	Antenna Height	Table Degree
		MHz	dBuV	dB	dBuV/m	dBuV/m	dB	cm	degree
1	*	2461.800	91.29	-3.40	87.89	74.00	13.89	peak	
2		2483.500	50.17	-3.38	46.79	74.00	-27.21	peak	

hopping-on

Conducted Method

Band Edge NVNT 1-DH1 2402MHz Ant1 Hopping Emission

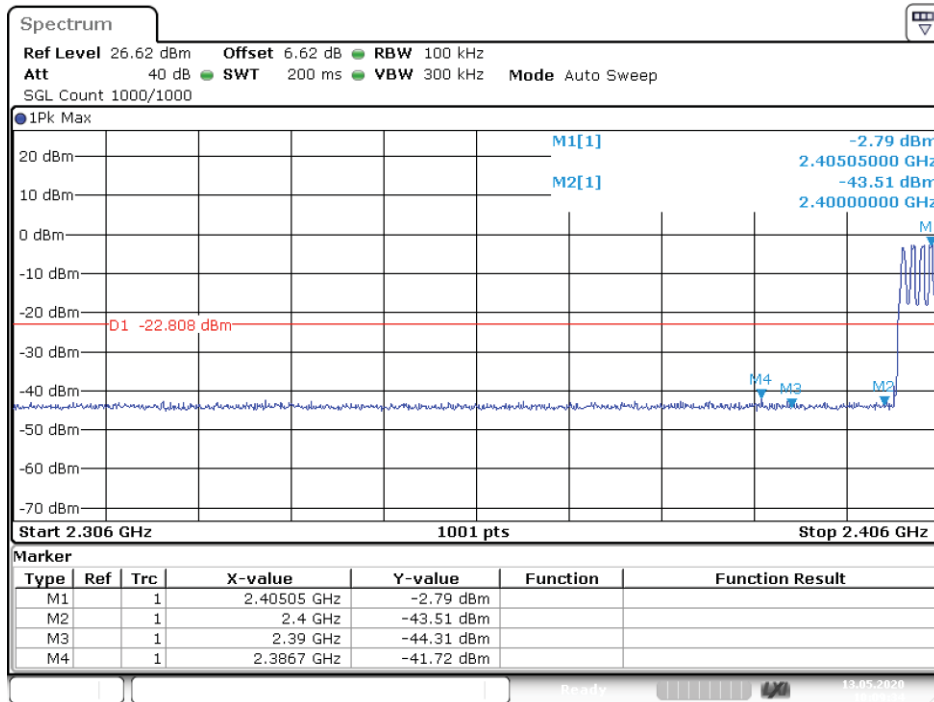

Date: 13.MAY.2020 10:09:34

Band Edge NVNT 1-DH1 2402MHz Ant1 No-Hopping Emission

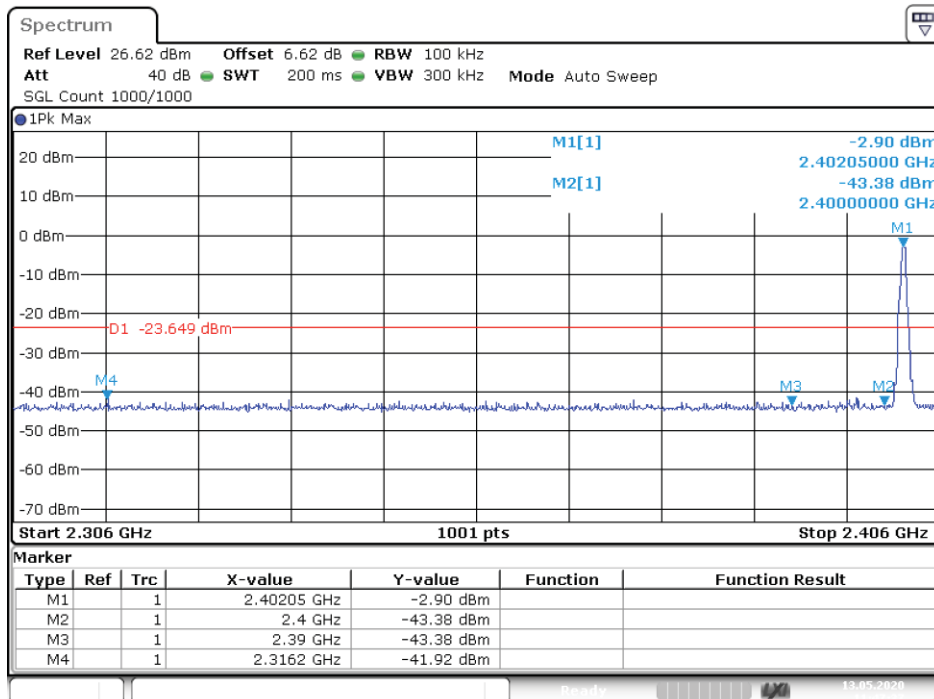

Date: 13.MAY.2020 11:47:37