



TEST REPORT

Report Reference No...... : **TRE1709025601** R/C.....: 18003

FCC ID..... : **PLE-GB-5420B**

Applicant's name..... : **Gigastone Corp.**

Address..... : 12F, No. 480, Rueiguang Rd., Neihu Dist., Taipei 114, Taiwan

Manufacturer..... : Gblue Technology CO., LTD.

Address..... : 2nd floor, Fukang Commercial Plaza, Yousong Road, Longhua Avenue, Longhua New District, Shenzhen

Test item description : **Bluetooth Headset**

Trade Mark : Gigastone

Model/Type reference..... : GB-5420B

Listed Model(s) : GB-5420R

Standard : **FCC CFR Title 47 Part 15 Subpart C Section 15.247**

Date of receipt of test sample..... : Sept. 29, 2017

Date of testing..... : Sept. 30, 2017 - Oct. 17, 2017

Date of issue..... : Oct. 18, 2017

Result..... : **PASS**

Compiled by
(Position+Printed name+Signature): File administrators Becky Liang

Supervised by
(Position+Printed name+Signature): Project Engineer John Qiao

Approved by
(Position+Printed name+Signature): RF Manager Hans Hu

Testing Laboratory Name : **Shenzhen Huatongwei International Inspection Co., Ltd.**

Address..... : 1/F, Bldg 3, Hongfa Hi-tech Industrial Park, Genyu Road, Tianliao, Gongming, Shenzhen, China

Shenzhen Huatongwei International Inspection Co., Ltd. All rights reserved.

This publication may be reproduced in whole or in part for non-commercial purposes as long as the Shenzhen Huatongwei International Inspection Co., Ltd. is acknowledged as copyright owner and source of the material. Shenzhen Huatongwei International Inspection Co., Ltd. takes no responsibility for and will not assume liability for damages resulting from the reader's interpretation of the reproduced material due to its placement and context.

The test report merely correspond to the test sample.

Contents

1.	<u>TEST STANDARDS AND REPORT VERSION</u>	3
1.1.	Test Standards	3
1.2.	Report version	3
2.	<u>TEST DESCRIPTION</u>	4
3.	<u>SUMMARY</u>	5
3.1.	Client Information	5
3.2.	Product Description	5
3.3.	Operation state	6
3.4.	EUT configuration	6
3.5.	Modifications	6
4.	<u>TEST ENVIRONMENT</u>	7
4.1.	Address of the test laboratory	7
4.2.	Test Facility	7
4.3.	Environmental conditions	8
4.4.	Statement of the measurement uncertainty	8
4.5.	Equipments Used during the Test	9
5.	<u>TEST CONDITIONS AND RESULTS</u>	10
5.1.	Antenna requirement	10
5.2.	Conducted Emissions (AC Main)	11
5.3.	Conducted Peak Output Power	14
5.4.	20 dB Bandwidth	21
5.5.	Carrier Frequencies Separation	28
5.6.	Hopping Channel Number	31
5.7.	Dwell Time	34
5.8.	Pseudorandom Frequency Hopping Sequence	41
5.9.	Restricted band (radiated)	42
5.10.	Band edge and Spurious Emissions (conducted)	44
5.11.	Spurious Emissions (radiated)	75
6.	<u>TEST SETUP PHOTOS</u>	79
7.	<u>EXTERANAL AND INTERNAL PHOTOS</u>	81

1. TEST STANDARDS AND REPORT VERSION

1.1. Test Standards

The tests were performed according to following standards:

[FCC Rules Part 15.247](#): Frequency Hopping, Direct Spread Spectrum and Hybrid Systems that are in operation within the bands of 902-928 MHz, 2400-2483.5 MHz, and 5725-5850 MHz

[ANSI C63.10-2013](#): American National Standard for Testing Unlicensed Wireless Devices

1.2. Report version

Version No.	Date of issue	Description
00	Oct. 18, 2017	Original

2. TEST DESCRIPTION

Test Item	Section in CFR 47	Result	Test Engineer
Antenna Requirement	15.203/15.247 (c)	Pass	William Wang
AC Power Line Conducted Emissions	15.207	Pass	William Wang
Conducted Peak Output Power	15.247 (b)(1)	Pass	William Wang
20 dB Bandwidth	15.247 (a)(1)	Pass	William Wang
Carrier Frequencies Separation	15.247 (a)(1)	Pass	William Wang
Hopping Channel Number	15.247 (a)(1)	Pass	William Wang
Dwell Time	15.247 (a)(1)	Pass	William Wang
Pseudorandom Frequency Hopping Sequence	15.247(b)(4)	Pass	William Wang
Restricted band	15.247(d)/15.205	Pass	William Wang
Radiated Emissions	15.247(d)/15.209	Pass	William Wang

Note: The measurement uncertainty is not included in the test result.

3. SUMMARY

3.1. Client Information

Applicant:	Gigastone Corp.
Address:	12F, No. 480, Rueiguang Rd., Neihu Dist., Taipei 114, Taiwan
Manufacturer:	Gblue Technology CO., LTD.
Address:	2nd floor, Fukang Commercial Plaza, Yousong Road, Longhua Avenue, Longhua New District, Shenzhen

3.2. Product Description

Name of EUT:	Bluetooth Headset
Trade Mark:	Gigastone
Model No.:	GB-5420B
Listed Model(s):	GB-5420R
Power supply:	DC 5V from USB port
Adapter information:	-
Hardware version:	IN-JTGS442-AB 15 2 2 S-V02
Software version:	03_AB1522S_V021_JT_201 70502_BT213.air of1ashZ
Bluetooth	
Version:	Supported BT4.2+EDR
Modulation:	GFSK, $\pi/4$ DQPSK, 8DPSK
Operation frequency:	2402MHz~2480MHz
Channel number:	79
Channel separation:	1MHz
Antenna type:	Intergral Antenna
Antenna gain:	0 dBi

3.3. Operation state

➤ Test frequency list

According to section 15.31(m), regards to the operating frequency range over 10 MHz, must select three channel which were tested. the Lowest frequency, the middle frequency, and the highest frequency of channel were selected to perform the test, please see the above gray bottom.

Channel	Frequency (MHz)
00	2402
01	2403
⋮	⋮
39	2441
⋮	⋮
77	2479
78	2480

➤ TEST MODE

For RF test items:
The engineering test program was provided and enabled to make EUT continuous transmit
For AC power line conducted emissions:
The EUT was set to connect with the Bluetooth instrument under large package sizes transmission.
For Radiated suprious emissions test item:
The EUT in each of three orthogonal axis emissions had been tested ,but only the worst case (X axis) data recorded in the report.

3.4. EUT configuration

The following peripheral devices and interface cables were connected during the measurement:

- - supplied by the manufacturer
- - supplied by the lab

○	AC Adapter	Model No.:	GTM46101-1005-USB
		Input:	100-240Va.c., 50-60Hz, 0.3A
		Output:	5Vd.c., 2.0A
	/	Manufacturer:	/
		Model No.:	/

3.5. Modifications

No modifications were implemented to meet testing criteria.

4. TEST ENVIRONMENT

4.1. Address of the test laboratory

Laboratory: Shenzhen Huatongwei International Inspection Co., Ltd.

Address: 1/F, Bldg 3, Hongfa Hi-tech Industrial Park, Genyu Road, Tianliao, Gongming, Shenzhen, China

4.2. Test Facility

CNAS-Lab Code: L1225

Shenzhen Huatongwei International Inspection Co., Ltd. has been assessed and proved to be in compliance with CNAS-CL01 Accreditation Criteria for Testing and Calibration Laboratories (identical to ISO/IEC17025: 2005 General Requirements) for the Competence of Testing and Calibration Laboratories.

A2LA-Lab Cert. No.: 3902.01

Shenzhen Huatongwei International Inspection Co., Ltd. EMC Laboratory has been accredited by A2LA for technical competence in the field of electrical testing, and proved to be in compliance with ISO/IEC 17025: 2005 General Requirements for the Competence of Testing and Calibration Laboratories and any additional program requirements in the identified field of testing.

FCC-Registration No.: 762235

Shenzhen Huatongwei International Inspection Co., Ltd. EMC Laboratory has been registered and fully described in a report filed with the FCC (Federal Communications Commission). The acceptance letter from the FCC is maintained in our files.

IC-Registration No.:5377B-1

Two 3m Alternate Test Site of Shenzhen Huatongwei International Inspection Co., Ltd. has been registered by Certification and Engineering Bureau of Industry Canada for the performance of radiated measurements with Registration No.: 5377B-1.

ACA

Shenzhen Huatongwei International Inspection Co., Ltd. EMC Laboratory can also perform testing for the Australian C-Tick mark as a result of our A2LA accreditation.

4.3. Environmental conditions

During the measurement the environmental conditions were within the listed ranges:

Temperature:	15~35°C
Relative Humidity:	30~60 %
Air Pressure:	950~1050mba

4.4. Statement of the measurement uncertainty

The data and results referenced in this document are true and accurate. The reader is cautioned that there may be errors in calibration limits of the equipment and facilities. The measurement uncertainty was calculated for all measurements listed in this test report according to TR-100028-01 "Electromagnetic compatibility and Radio spectrum Matters (ERM); Uncertainties in the measurement of mobile radio equipment characteristics; Part 1" and TR-100028-02 "Electromagnetic compatibility and Radio spectrum Matters (ERM); Uncertainties in the measurement of mobile radio equipment characteristics; Part 2" and is documented in the Shenzhen Huatongwei International Inspection Co., Ltd. quality system according to ISO/IEC 17025. Furthermore, component and process variability of devices similar to that tested may result in additional deviation. The manufacturer has the sole responsibility of continued compliance of the device.

Here after the best measurement capability for Shenzhen Huatongwei International Inspection Co., Ltd. is reported:

Test Items	Measurement Uncertainty	Notes
Transmitter power conducted	0.57 dB	(1)
Transmitter power Radiated	2.20 dB	(1)
Conducted spurious emissions 9kHz~40GHz	1.60 dB	(1)
Radiated spurious emissions 9kHz~40GHz	2.20 dB	(1)
Conducted Emissions 9kHz~30MHz	3.39 dB	(1)
Radiated Emissions 30~1000MHz	4.24 dB	(1)
Radiated Emissions 1~18GHz	5.16 dB	(1)
Radiated Emissions 18~40GHz	5.54 dB	(1)
Occupied Bandwidth	-----	(1)

(1) This uncertainty represents an expanded uncertainty expressed at approximately the 95% confidence level using a coverage factor of $k=1.96$.

4.5. Equipments Used during the Test

Conducted Emissions					
Item	Test Equipment	Manufacturer	Model No.	Serial No.	Last Cal.
1	Artificial Mains	Rohde&Schwarz	ESH2-Z5	100028	2016/11/13
2	EMI Test Receiver	Rohde&Schwarz	ESCI3	100038	2016/11/13
3	Pulse Limiter	Rohde&Schwarz	ESHSZ2	100044	2016/11/13
4	EMI Test Software	Rohde&Schwarz	ES-K1 V1.71	-	-

Radiated Emissions					
Item	Test Equipment	Manufacturer	Model No.	Serial No.	Last Cal.
1	EMI test receiver	Rohde&Schwarz	ESI 26	100009	2016/11/13
2	Loop Antenna	Rohde&Schwarz	HFH2-Z2	100020	2016/11/13
3	Ultra-Broadband Antenna	ShwarzBeck	VULB9163	538	2016/11/13
4	Horn antenna	ShwarzBeck	9120D	1011	2016/11/13
5	Horn Antenna	SCHWARZBECK	BBHA9170	25841	2016/11/13
6	Amplifier	Sonoma	310N	E009-13	2016/11/13
7	JS Amplifier	Rohde&Schwarz	JS4-00101800-28-5A	F201504	2016/11/13
8	Amplifier	Compliance Direction systems	PAP1-4060	120	2016/11/13
9	High pass filter	Compliance Direction systems	BSU-6	34202	2016/11/13
10	EMI test Software	Rohde&Schwarz	ESK1	-	-
11	EMI test Software	Audix	E3	-	-
12	TURNTABLE	MATURO	TT2.0	-	-
13	ANTENNA MAST	MATURO	TAM-4.0-P	-	-

RF Conducted methods					
Item	Test Equipment	Manufacturer	Model No.	Serial No.	Last Cal.
1	Spectrum Analyzer	Rohde&Schwarz	FSP	1164.4391.40	2016/11/13
2	MXA Signal Analyzer	Agilent Technologies	N9020A	MY5050187	2016/11/13

The Cal.Interval was one year.

5. TEST CONDITIONS AND RESULTS

5.1. Antenna requirement

Requirement

FCC CFR Title 47 Part 15 Subpart C Section 15.203:

An intentional radiator shall be designed to ensure that no antenna other than that furnished by the responsible party shall be used with the device. The use of a permanently attached antenna or of an antenna that uses a unique coupling to the intentional radiator, the manufacturer may design the unit so that a broken antenna can be replaced by the user, but the use of a standard antenna jack or electrical connector is prohibited.

FCC CFR Title 47 Part 15 Subpart C Section 15.247(c) (1)(i):

(i) Systems operating in the 2400~2483.5 MHz band that is used exclusively for fixed. Point-to-point operations may employ transmitting antennas with directional gain greater than 6 dBi provided the maximum conducted output power of the intentional radiator is reduced by 1 dB for every 3 dB that the directional gain of the antenna exceeds 6 dBi.

Test Result:

Passed **Not Applicable**

The directional gain of the antenna less than 6 dBi, please refer to the below antenna photo.

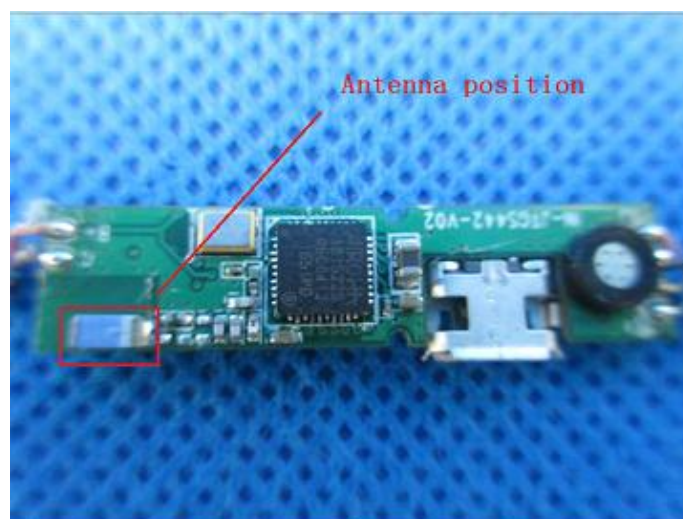

5.2. Conducted Emissions (AC Main)

LIMIT

FCC CFR Title 47 Part 15 Subpart C Section 15.207

Frequency range (MHz)	Limit (dBuV)	
	Quasi-peak	Average
0.15-0.5	66 to 56*	56 to 46*
0.5-5	56	46
5-30	60	50

* Decreases with the logarithm of the frequency.

TEST CONFIGURATION

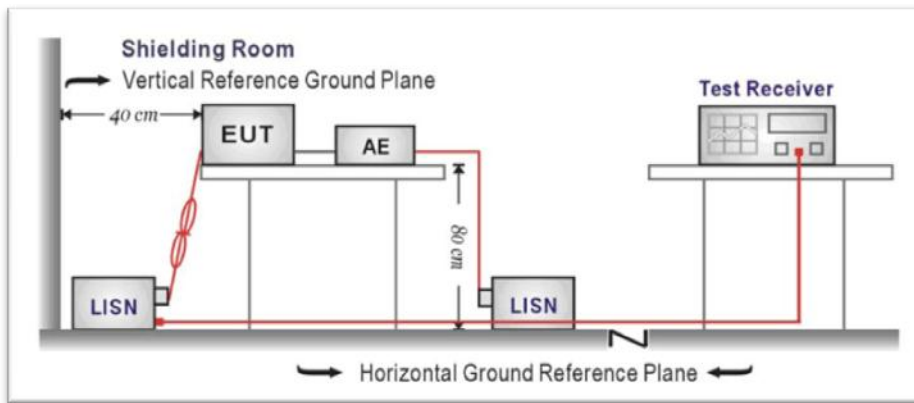

TEST PROCEDURE

1. The EUT was setup according to ANSI C63.10:2013 requirements.
2. The EUT was placed on a platform of nominal size, 1 m by 1.5 m, raised 80 cm above the conducting ground plane. The vertical conducting plane was located 40 cm to the rear of the EUT. All other surfaces of EUT were at least 80 cm from any other grounded conducting surface.
3. The EUT and simulators are connected to the main power through a line impedances stabilization network (LISN). The LISN provides a 50 ohm /50uH coupling impedance for the measuring equipment.
4. The peripheral devices are also connected to the main power through a LISN. (Please refer to the block diagram of the test setup and photographs)
5. Each current-carrying conductor of the EUT power cord, except the ground (safety) conductor, was individually connected through a LISN to the input power source.
6. The excess length of the power cord between the EUT and the LISN receptacle were folded back and forth at the center of the lead to form a bundle not exceeding 40 cm in length.
7. Conducted emissions were investigated over the frequency range from 0.15MHz to 30MHz using a receiver bandwidth of 9 kHz.
8. During the above scans, the emissions were maximized by cable manipulation.

TEST RESULTS

Passed Not Applicable

Note:

- 1) Transd= Cable lose + Pulse Limiter Factor + Artificial Mains Factor
- 2) Margin= Limit - Level

Test Line:

L

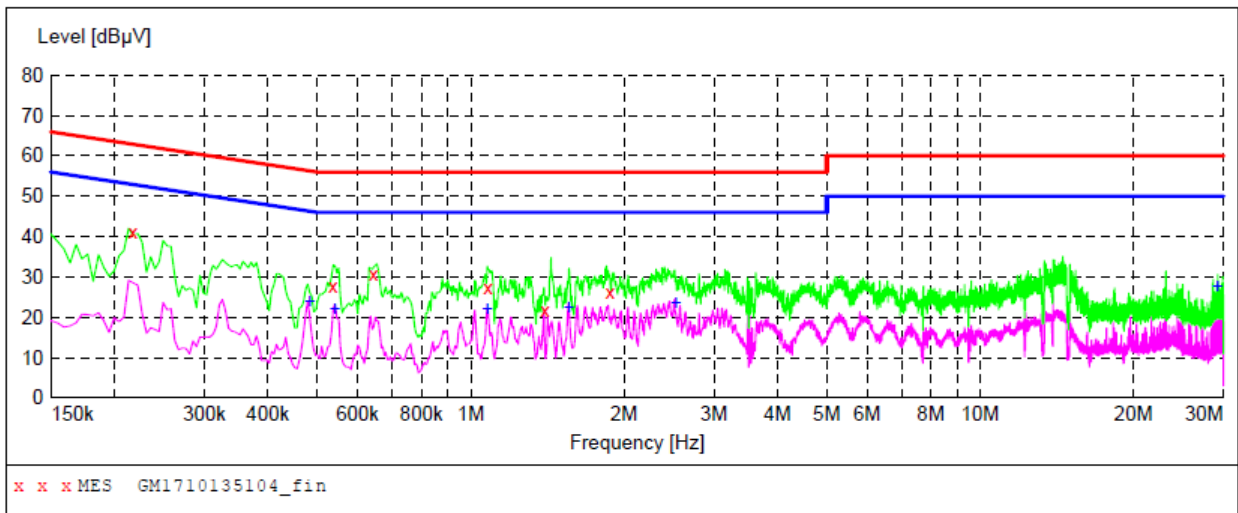

Frequency MHz	Level dBµV	Transd dB	Limit dBµV	Margin dB	Detector	Line	PE
0.217500	41.30	10.3	63	21.6	QP	L1	GND
0.537000	27.90	10.2	56	28.1	QP	L1	GND
0.645000	30.70	10.2	56	25.3	QP	L1	GND
1.081500	27.30	10.2	56	28.7	QP	L1	GND
1.401000	21.90	10.2	56	34.1	QP	L1	GND
1.878000	26.20	10.2	56	29.8	QP	L1	GND

Frequency MHz	Level dBµV	Transd dB	Limit dBµV	Margin dB	Detector	Line	PE
0.483000	24.20	10.2	46	22.1	AV	L1	GND
0.541500	22.20	10.2	46	23.8	AV	L1	GND
1.077000	22.00	10.2	46	24.0	AV	L1	GND
1.558500	22.60	10.2	46	23.4	AV	L1	GND
2.526000	23.70	10.2	46	22.3	AV	L1	GND
29.233500	27.70	10.8	50	22.3	AV	L1	GND

Test Line: N

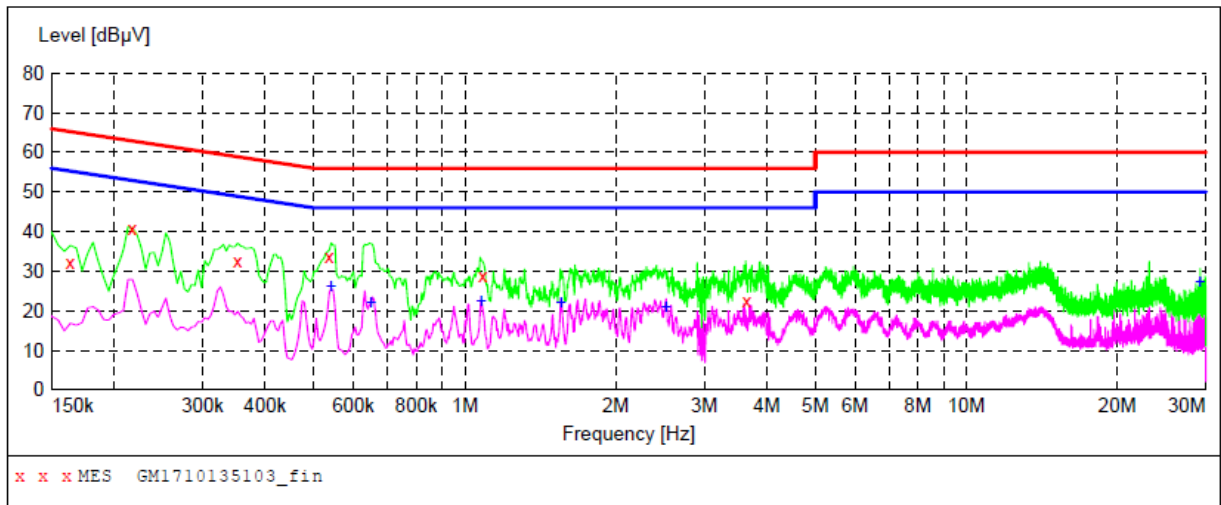

Frequency MHz	Level dBµV	Transd dB	Limit dBµV	Margin dB	Detector	Line	PE
0.163500	32.10	10.4	65	33.2	QP	N	GND
0.217500	40.90	10.3	63	22.0	QP	N	GND
0.352500	32.50	10.2	59	26.4	QP	N	GND
0.537000	33.60	10.2	56	22.4	QP	N	GND
1.086000	29.00	10.2	56	27.0	QP	N	GND
3.646500	22.50	10.3	56	33.5	QP	N	GND
Frequency MHz	Level dBµV	Transd dB	Limit dBµV	Margin dB	Detector	Line	PE
0.541500	26.10	10.2	46	19.9	AV	N	GND
0.649500	22.20	10.2	46	23.8	AV	N	GND
1.077000	22.50	10.2	46	23.5	AV	N	GND
1.554000	22.00	10.2	46	24.0	AV	N	GND
2.517000	21.20	10.2	46	24.8	AV	N	GND
29.233500	27.20	10.8	50	22.8	AV	N	GND

5.3. Conducted Peak Output Power

LIMIT

FCC CFR Title 47 Part 15 Subpart C Section 15.247 (b)(1): For frequency hopping systems operating in the 2400-2483.5 MHz band employing at least 75 non-overlapping hopping channels, and all frequency hopping systems in the 5725-5850 MHz band: 1 watt. For all other frequency hopping systems in the 2400-2483.5 MHz band: 0.125 watts.

TEST CONFIGURATION

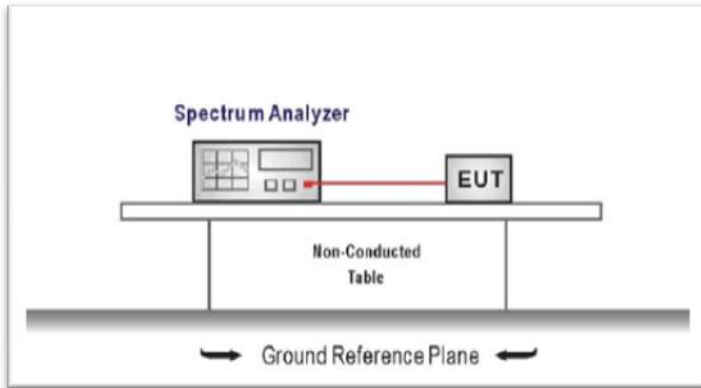

TEST PROCEDURE

1. The transmitter output was connected to the spectrum analyzer through an attenuator, the pathloss was compensated to the results for each measurement.
2. Set to the maximum power setting and enable the EUT transmit continuously
3. Use the following spectrum analyzer settings:
 Span = approximately 5 times the 20 dB bandwidth, centered on a hopping channel
 RBW ≥ the 20 dB bandwidth of the emission being measured, VBW ≥ RBW
 Sweep = auto, Detector function = peak, Trace = max hold
4. Measure and record the results in the test report.

TEST MODE:

Please refer to the clause 3.3

TEST RESULTS

Passed Not Applicable

Modulation type	Channel	Output power (dBm)	Limit (dBm)	Result
GFSK	00	6.147	≤ 30.00	Pass
	39	7.450		
	78	6.945		
π/4DQPSK	00	7.453	≤ 21.00	Pass
	39	8.373		
	78	8.121		
8DPSK	00	7.573	≤ 21.00	Pass
	39	8.509		
	78	8.282		

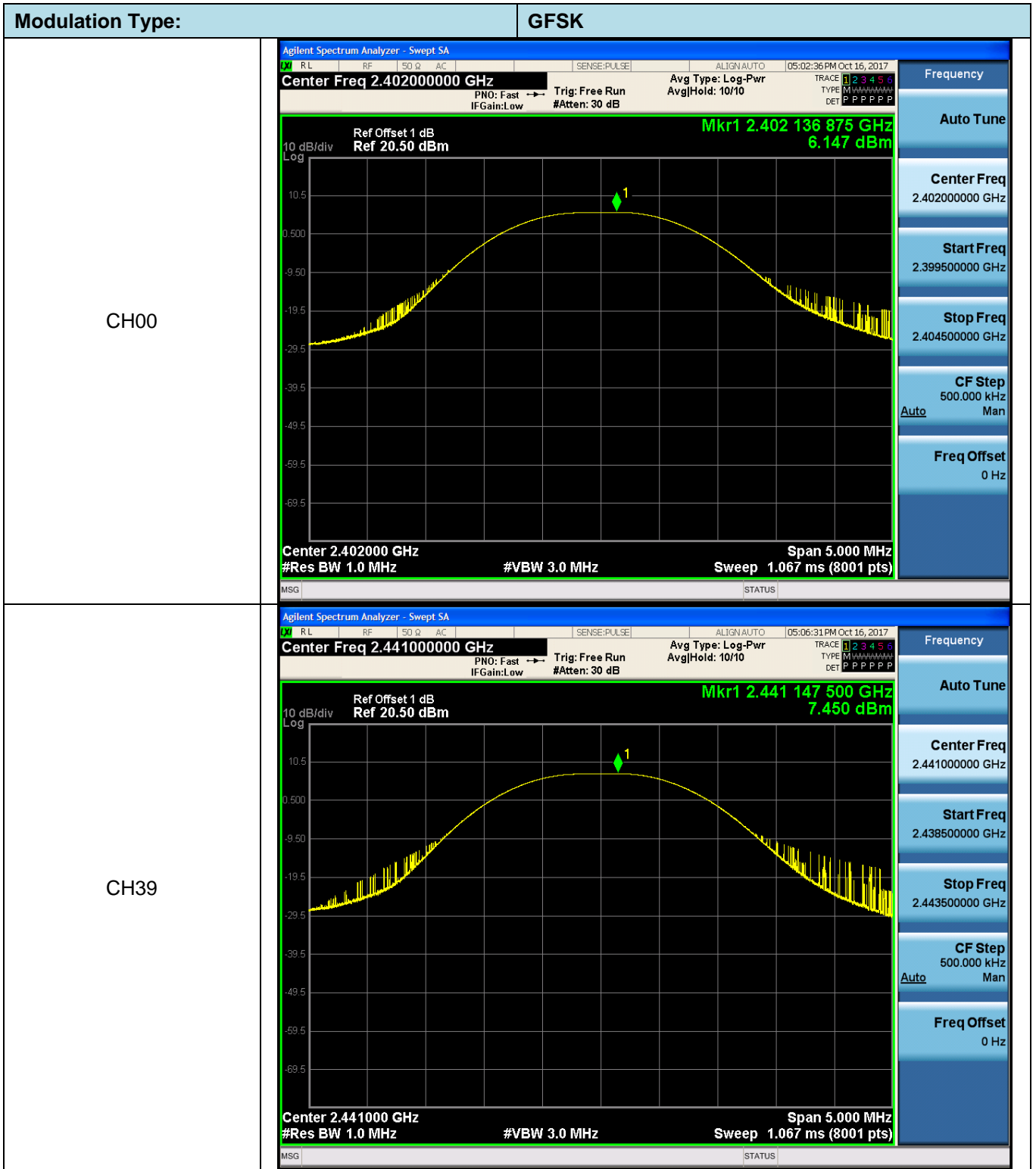

CH78

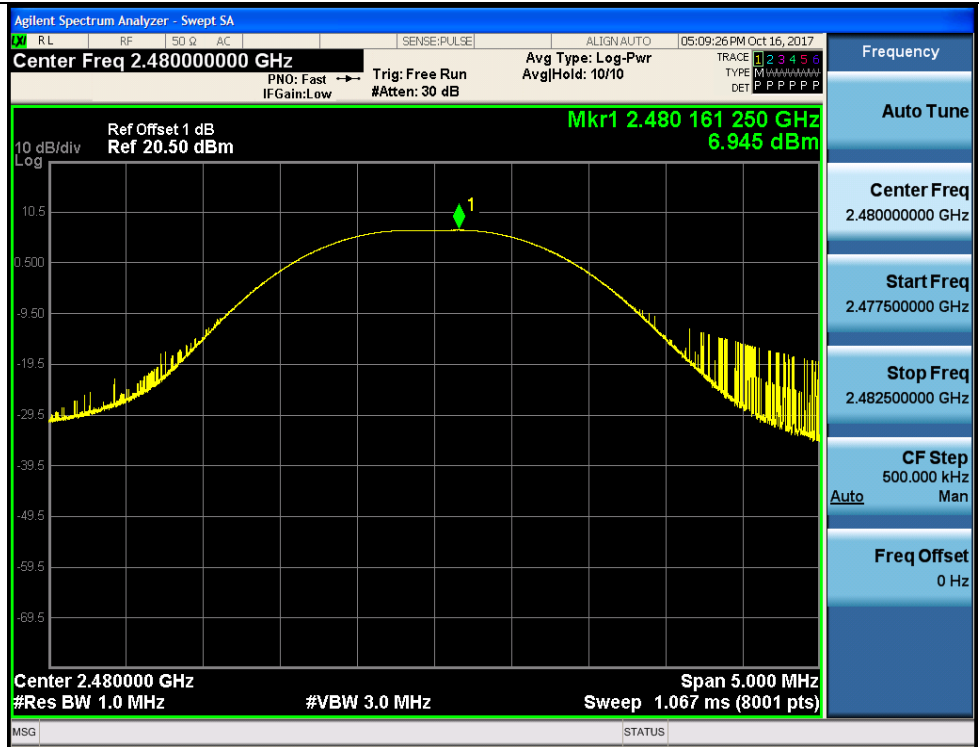

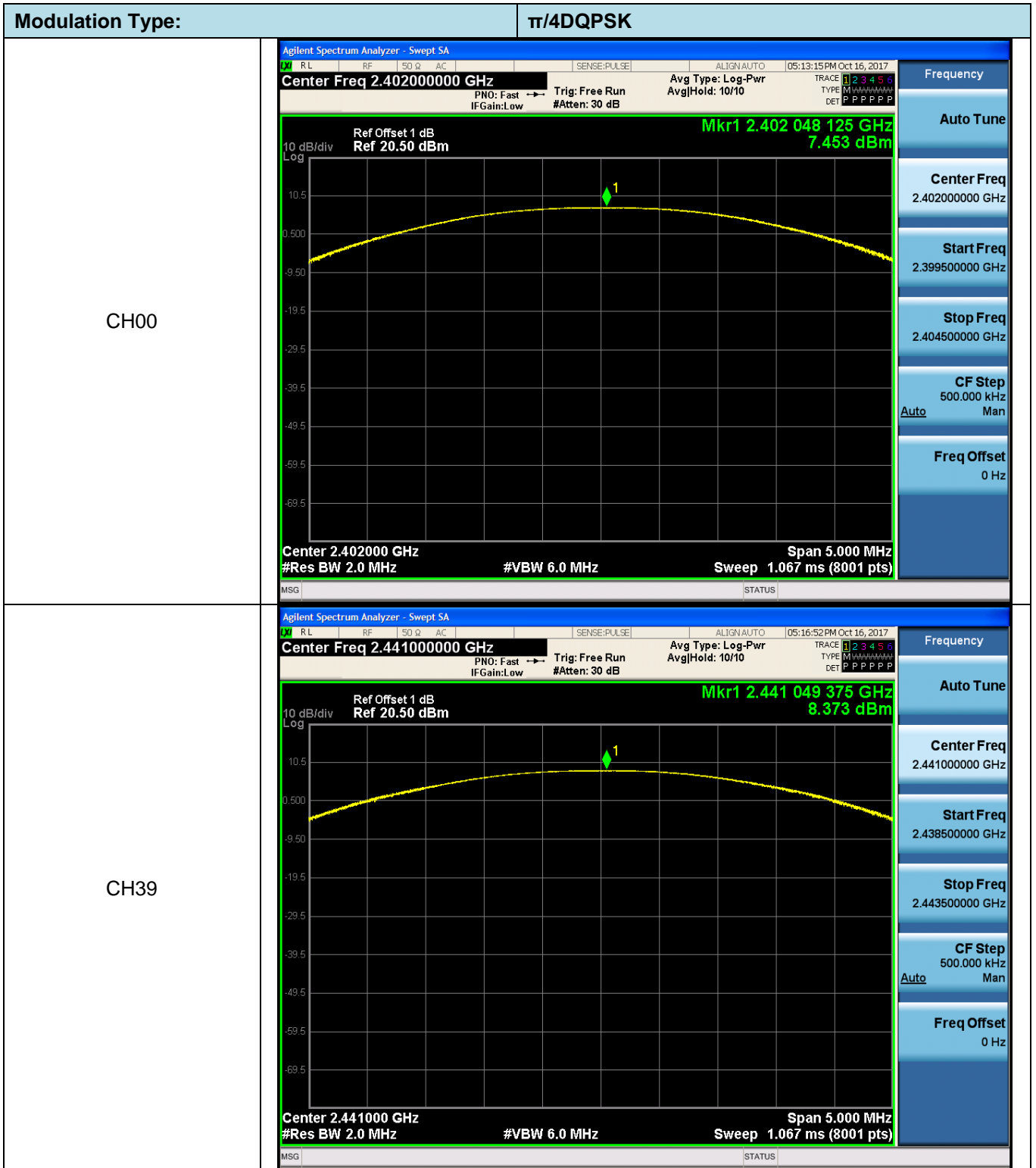

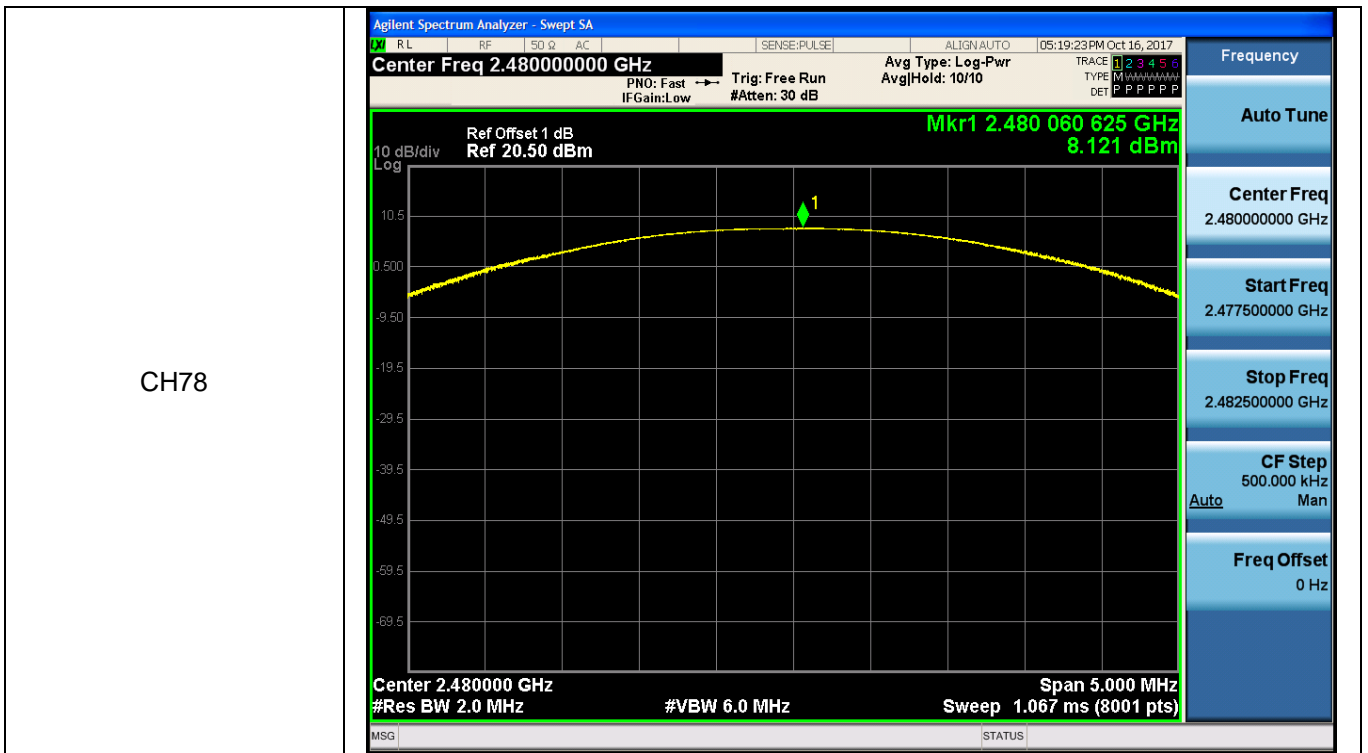

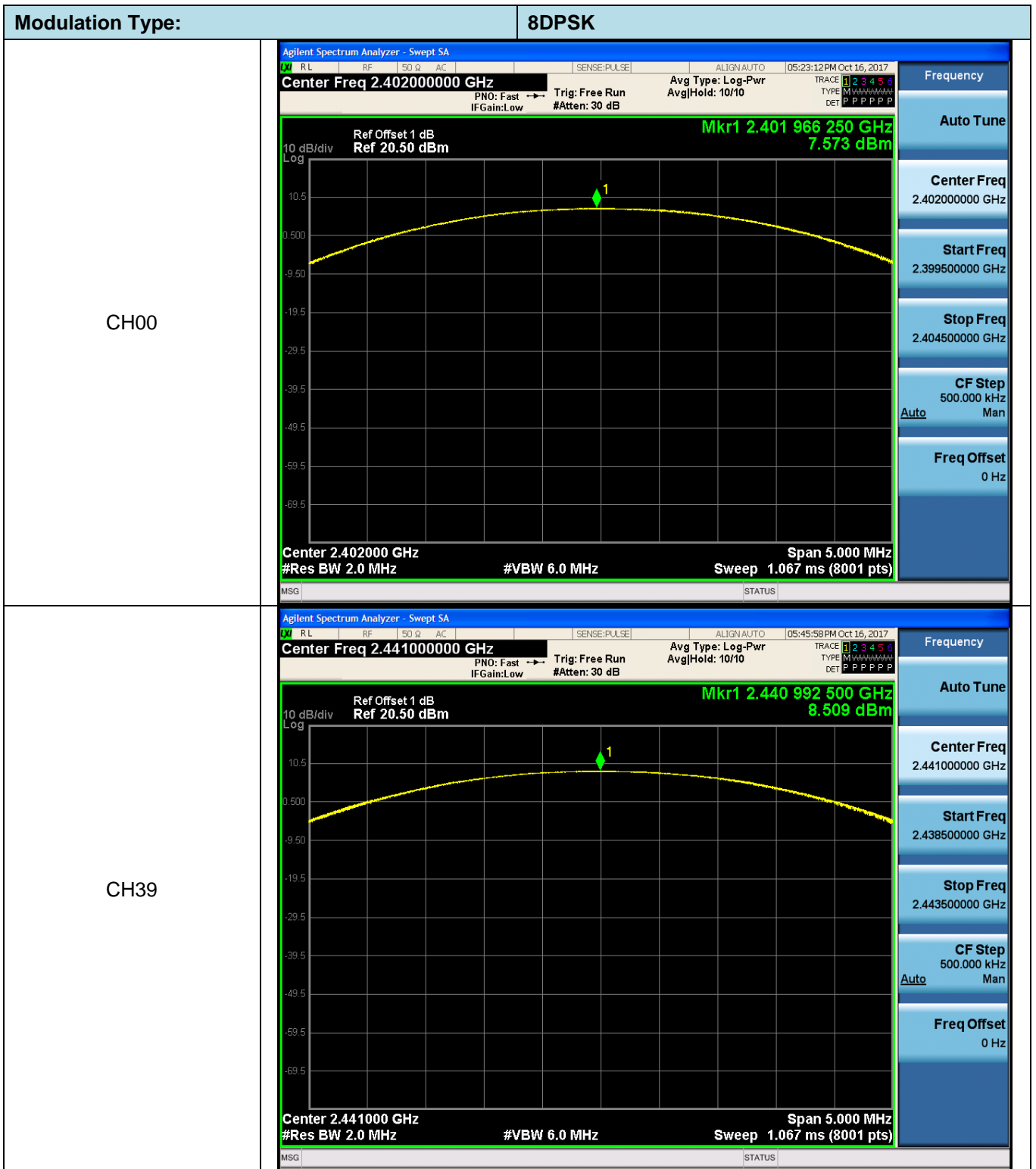

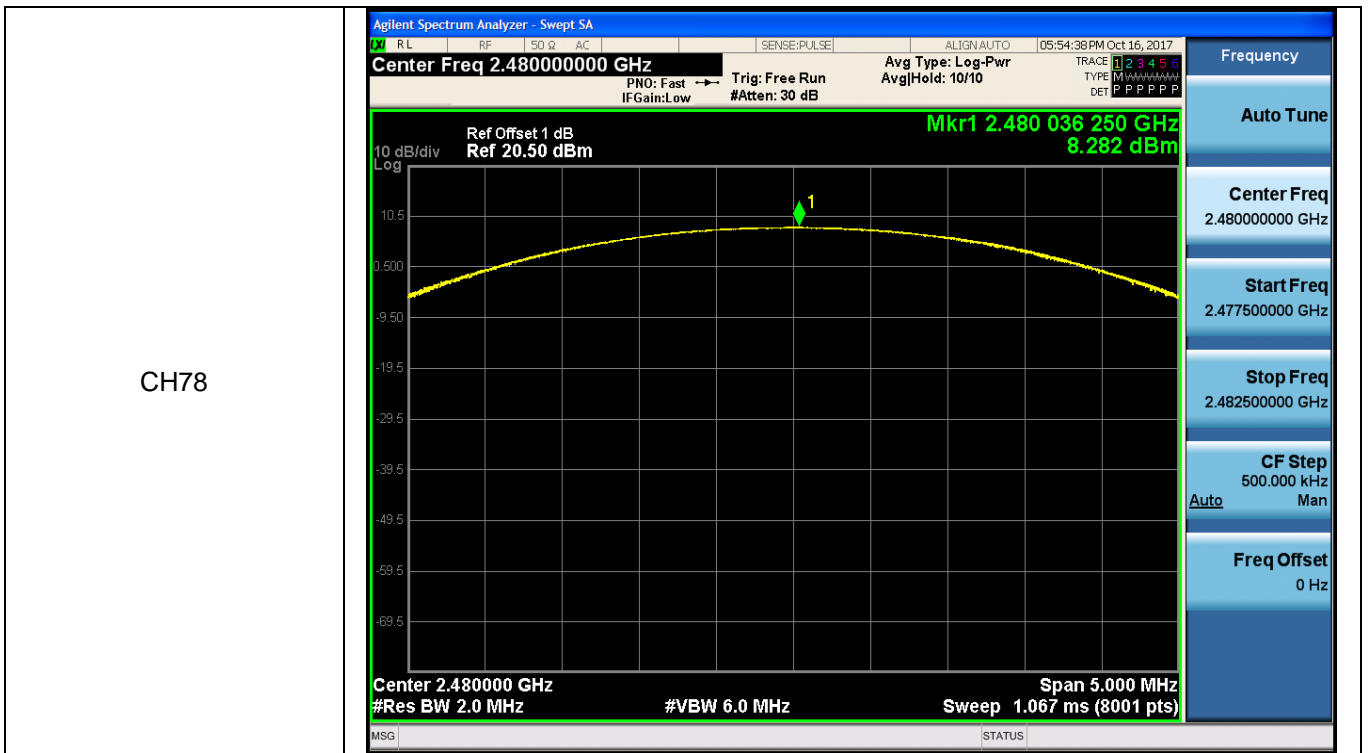

5.4. 20 dB Bandwidth

LIMIT

N/A

TEST CONFIGURATION

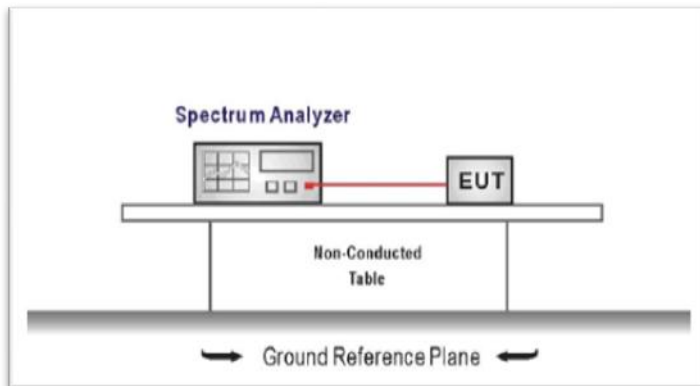

TEST PROCEDURE

1. The transmitter output was connected to the spectrum analyzer through an attenuator, the path loss was compensated to the results for each measurement.
2. Set to the maximum power setting and enable the EUT transmit continuously
3. Use the following spectrum analyzer settings:
Span = approximately 2 to 3 times the 20 dB bandwidth, centered on a hopping channel
RBW \geq 1% of the 20 dB bandwidth, VBW \geq RBW
Sweep = auto, Detector function = peak, Trace = max hold
4. Measure and record the results in the test report.

TEST MODE:

Please refer to the clause 3.3

TEST RESULTS

 Passed Not Applicable

Modulation type	Channel	20 dB Bandwidth (MHz)	Limit (MHz)	Result
GFSK	00	0.8416	-	Pass
	39	0.7908		
	78	0.8398		
$\pi/4$ DQPSK	00	1.263	-	Pass
	39	1.266		
	78	1.269		
8DPSK	00	1.269	-	Pass
	39	1.287		
	78	1.284		

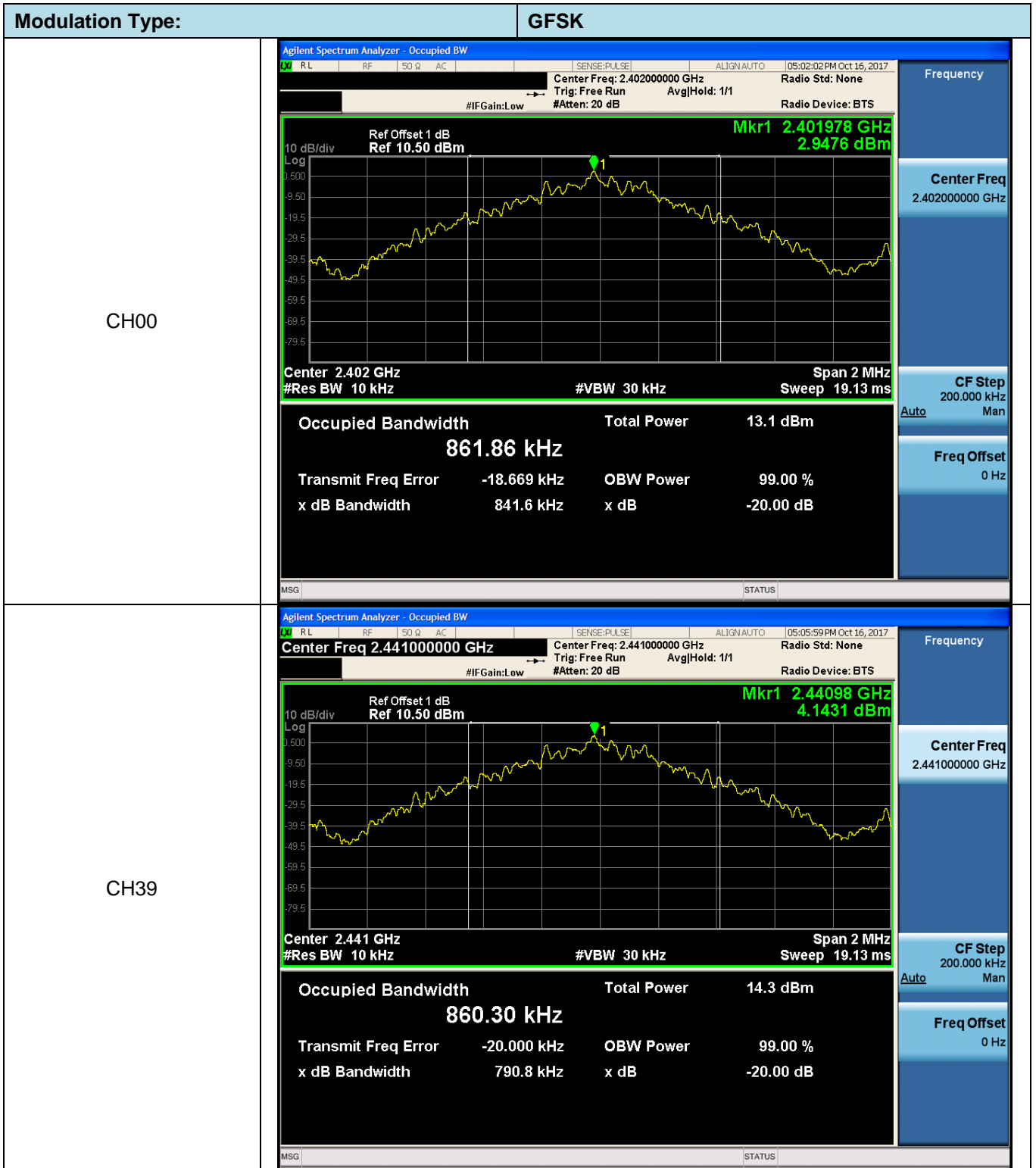

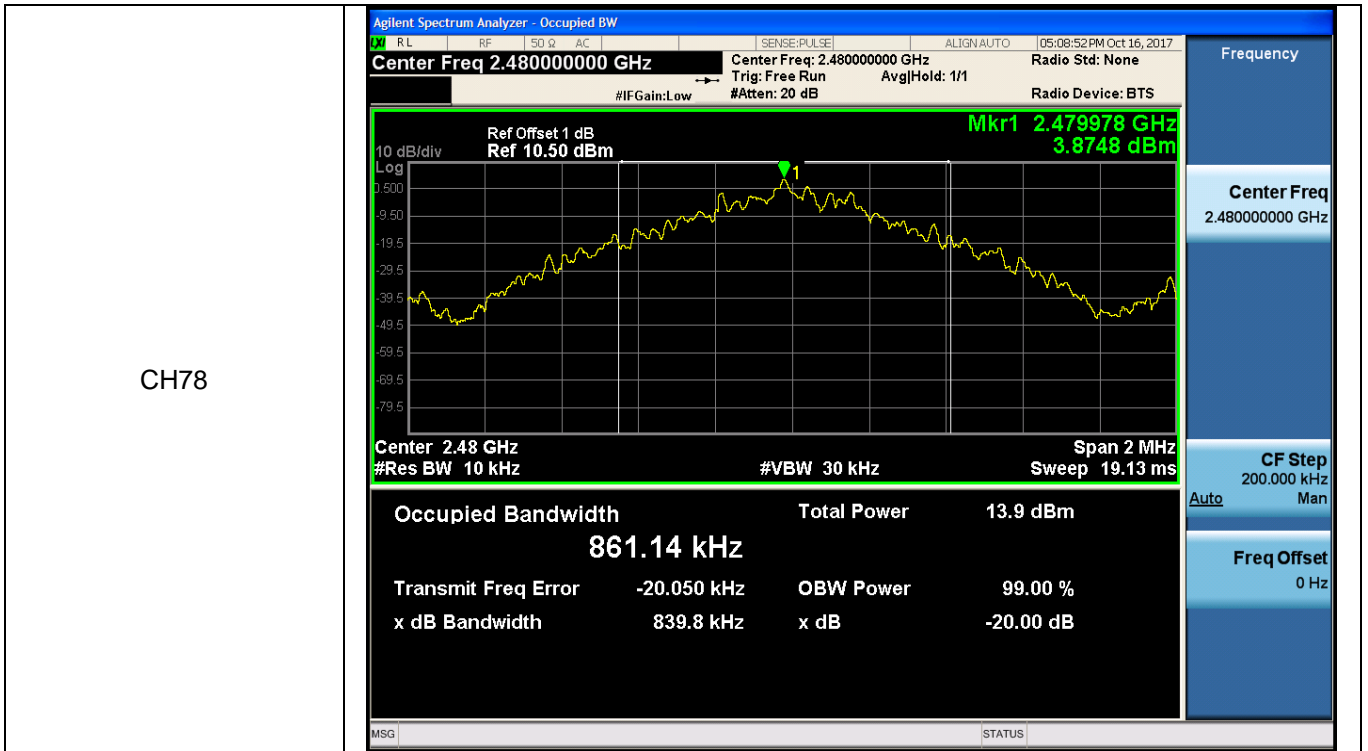

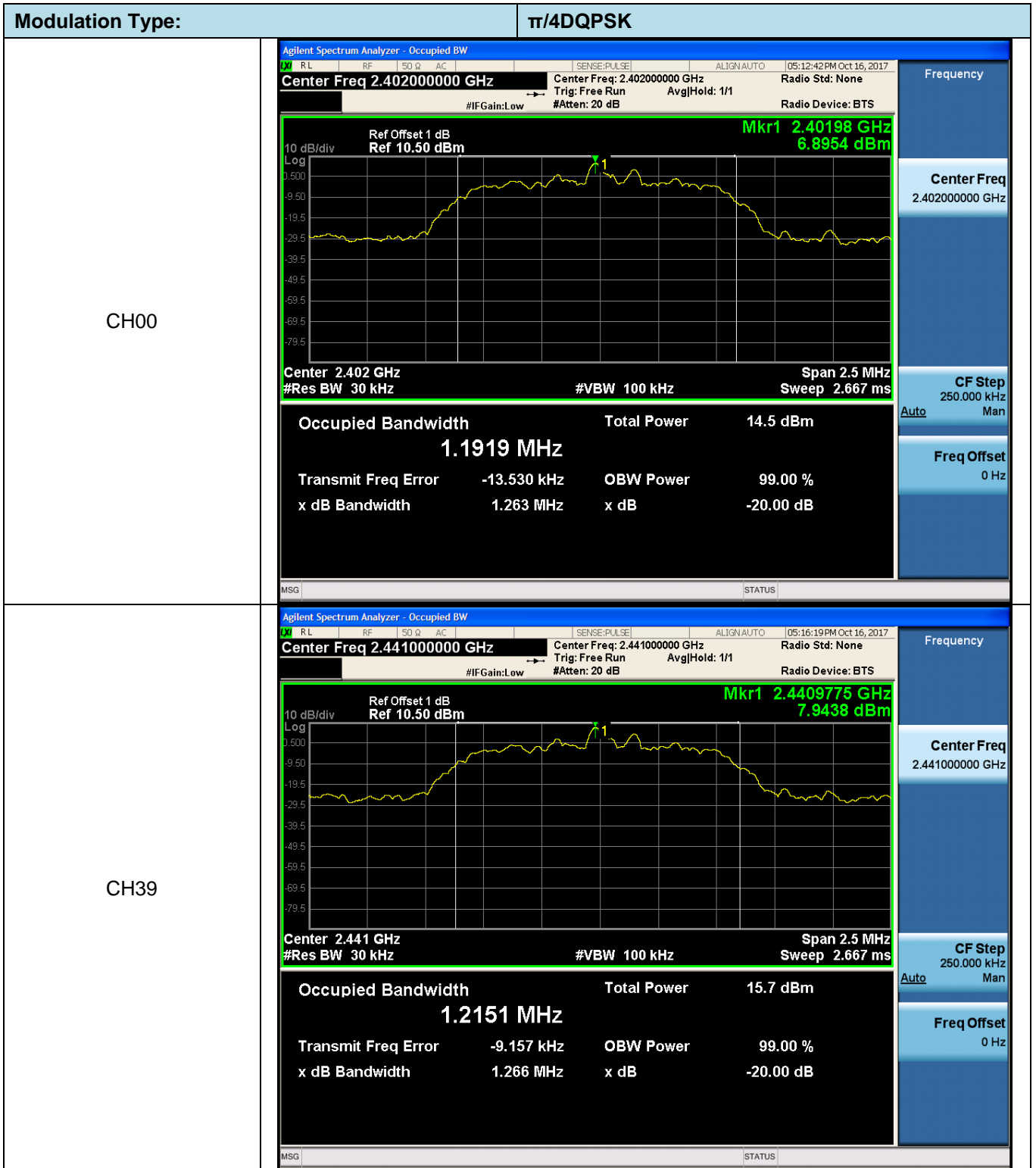

CH78

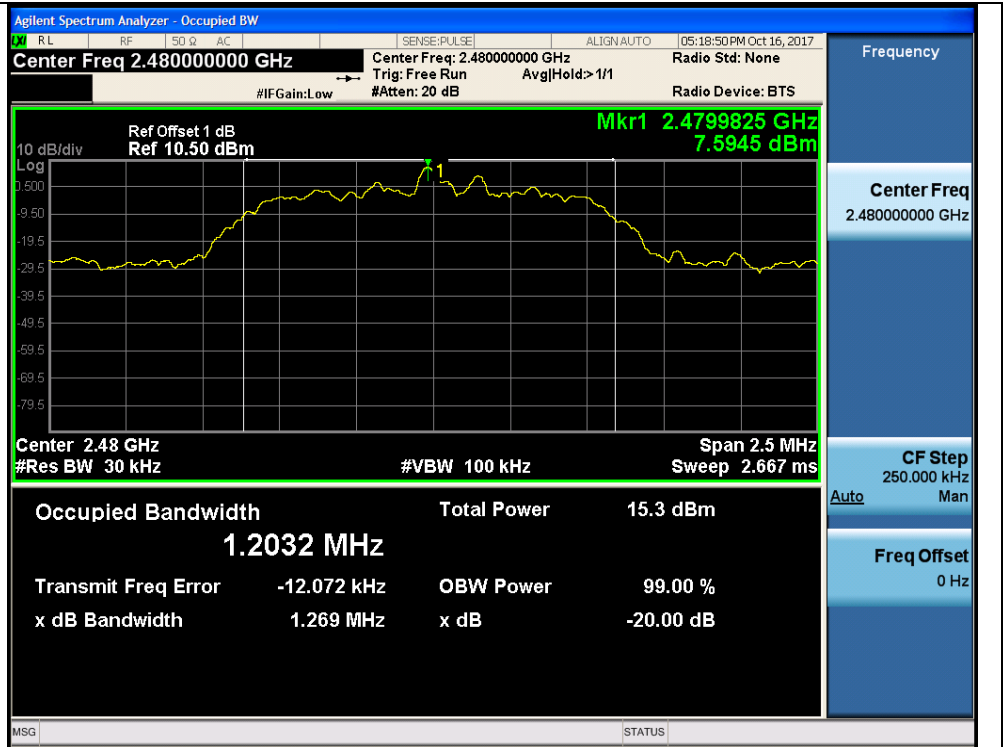

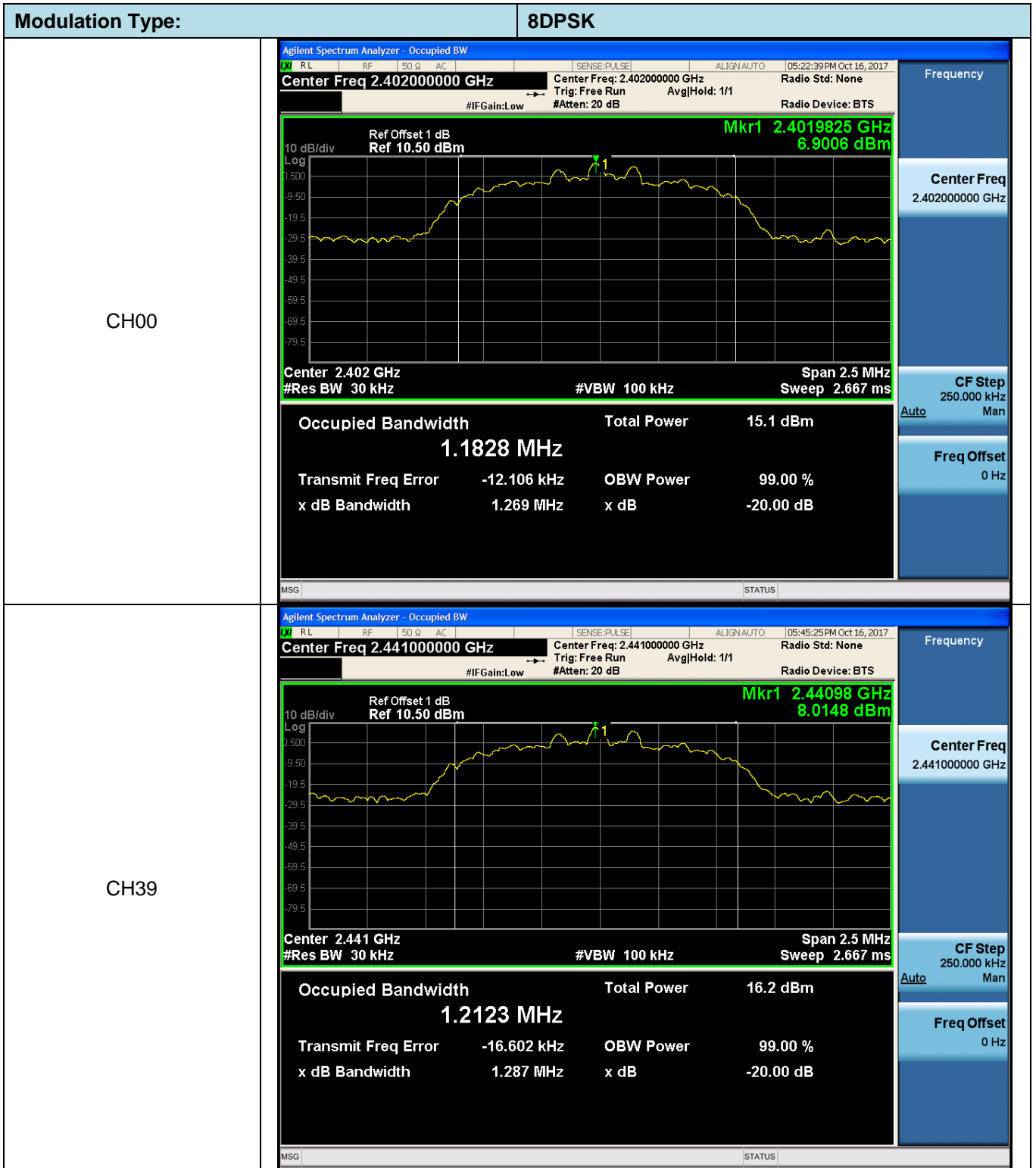

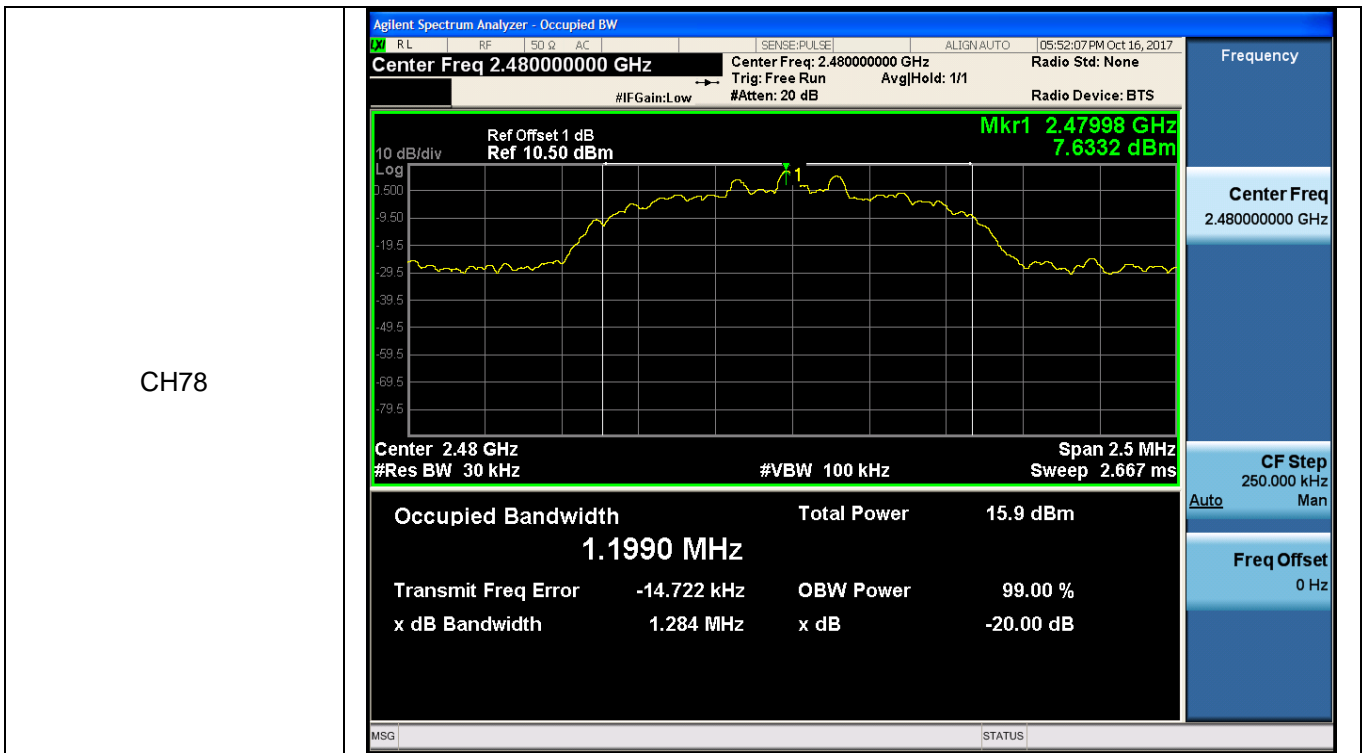

5.5. Carrier Frequencies Separation

LIMIT

FCC CFR Title 47 Part 15 Subpart C Section 15.247 (a)(1):Frequency hopping systems shall have hopping channel carrier frequencies separated by minimum of 25 kHz or the 2/3*20 dB bandwidth of the hopping channel, whichever is greater.

TEST CONFIGURATION

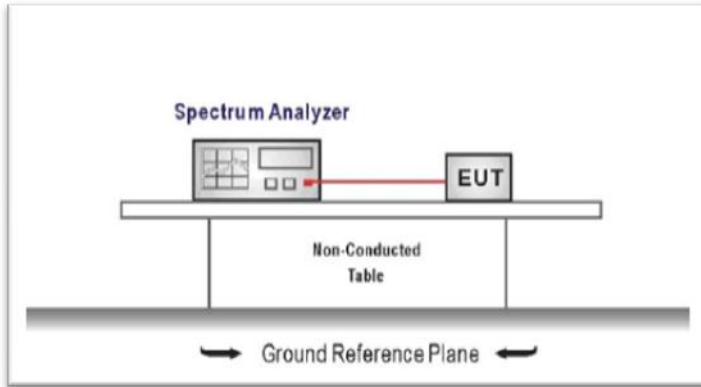

TEST PROCEDURE

1. The transmitter output was connected to the spectrum analyzer through an attenuator, the path loss was compensated to the results for each measurement.
2. Set to the maximum power setting and enable the EUT transmit continuously
3. Use the following spectrum analyzer settings:
 Span = wide enough to capture the peaks of two adjacent channels
 RBW ≥ 1% of the span, VBW ≥ RBW
 Sweep = auto, Detector function = peak, Trace = max hold
4. Measure and record the results in the test report.

TEST MODE:

Please refer to the clause 3.3

TEST RESULTS

Passed Not Applicable

Modulation type	Channel	Carrier Frequencies Separation (MHz)	Limit (MHz) *	Result
GFSK	39	1.014	≥0.842	Pass
π/4DQPSK	39	1.001	≥0.846	Pass
8DPSK	39	1.170	≥0.846	Pass

Note:

- *: GFSK limit = The maximum 20 dB Bandwidth for GFSK modulation on the section 5.4.
- π/4DQPSK limit = 2/3 * The maximum 20 dB Bandwidth for π/4DQPSK modulation on the section 5.4.
- 8DPSK limit = 2/3 * The maximum 20 dB Bandwidth for 8DPSK modulation on the section 5.4

GFSK



π /4DQPSK



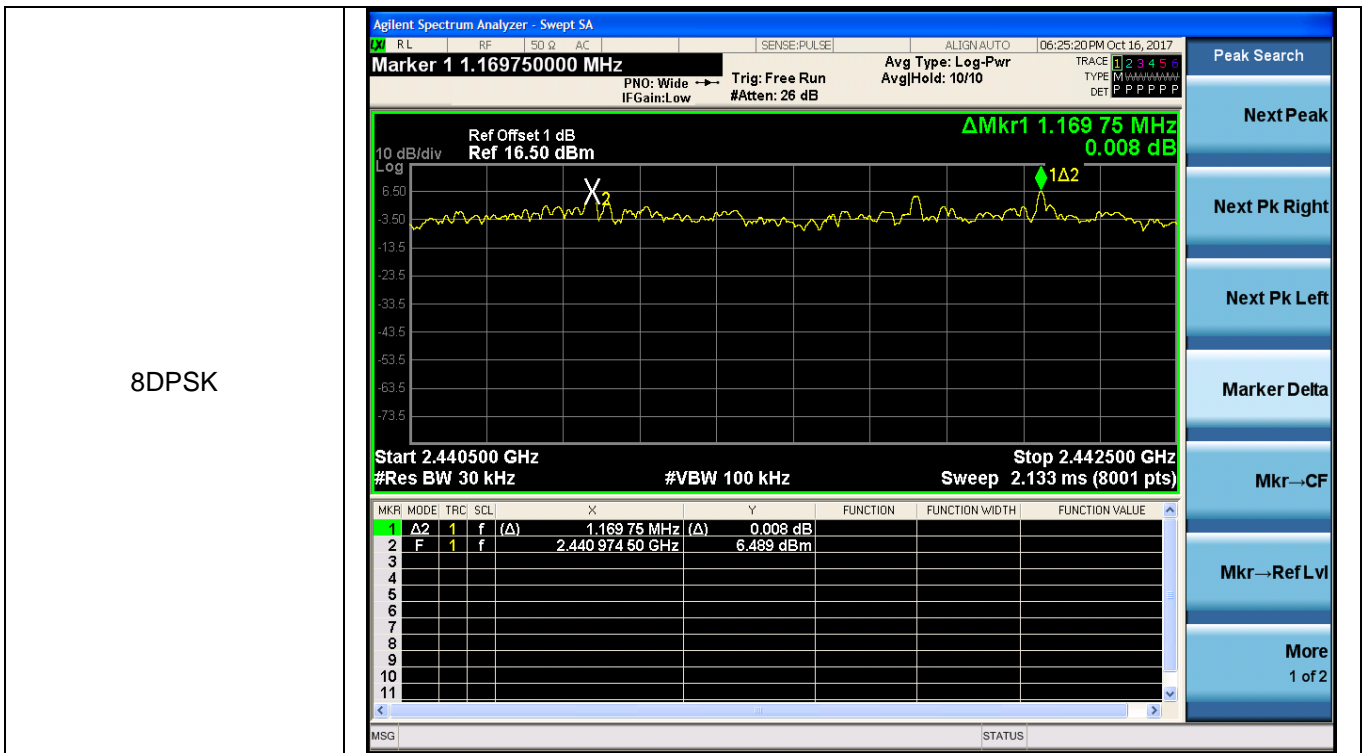

5.6. Hopping Channel Number

LIMIT

FCC CFR Title 47 Part 15 Subpart C Section 15.247 (a)(1): Frequency hopping systems in the 2400–2483.5 MHz band shall use at least **15** channels.

TEST CONFIGURATION

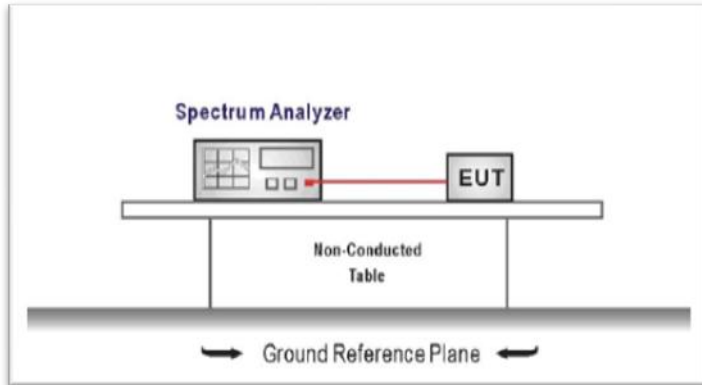

TEST PROCEDURE

1. The transmitter output was connected to the spectrum analyzer through an attenuator, the path loss was compensated to the results for each measurement.
2. Set to the maximum power setting and enable the EUT transmit continuously
3. Use the following spectrum analyzer settings:
 Span = the frequency band of operation
 RBW \geq 1% of the span, VBW \geq RBW
 Sweep = auto, Detector function = peak, Trace = max hold
4. Measure and record the results in the test report.

TEST MODE:

Please refer to the clause 3.3

TEST RESULTS

Passed Not Applicable

Modulation type	Channel number	Limit	Result
GFSK	79	≥ 15.00	Pass
$\pi/4$ DQPSK	79		
8DPSK	79		

GFSK

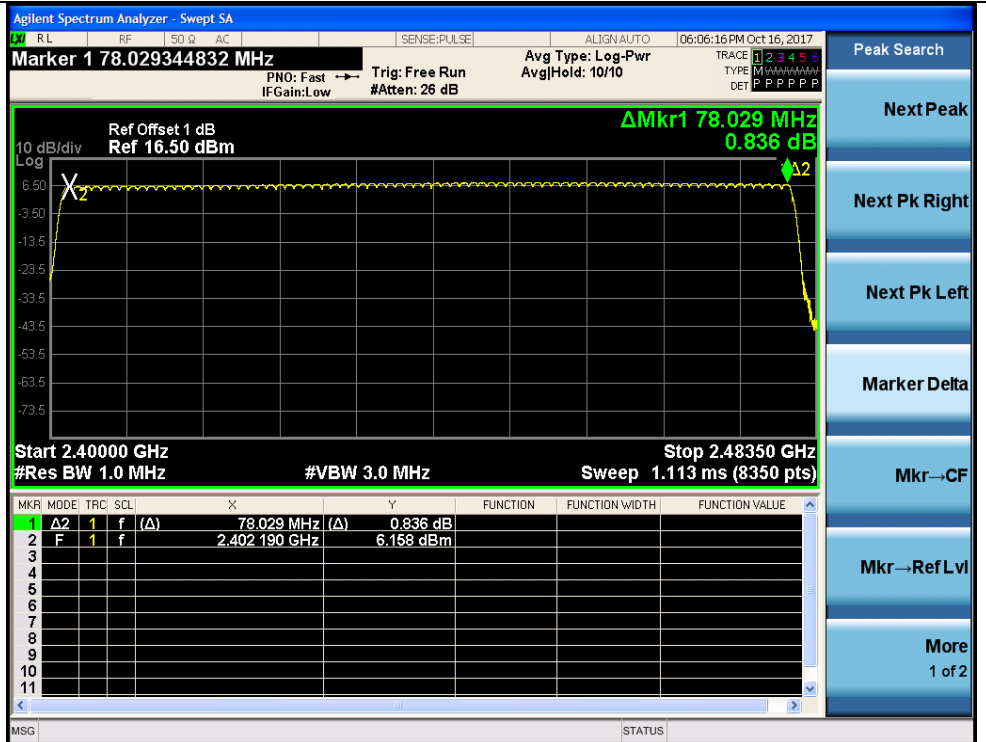

π /4DQPSK

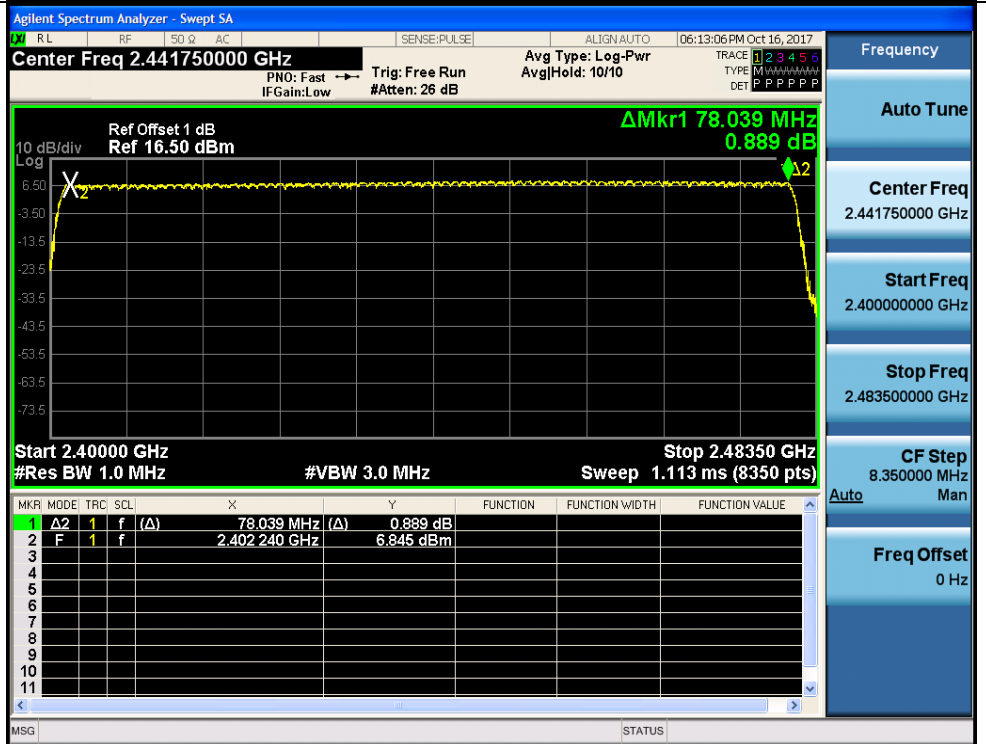

8DPSK

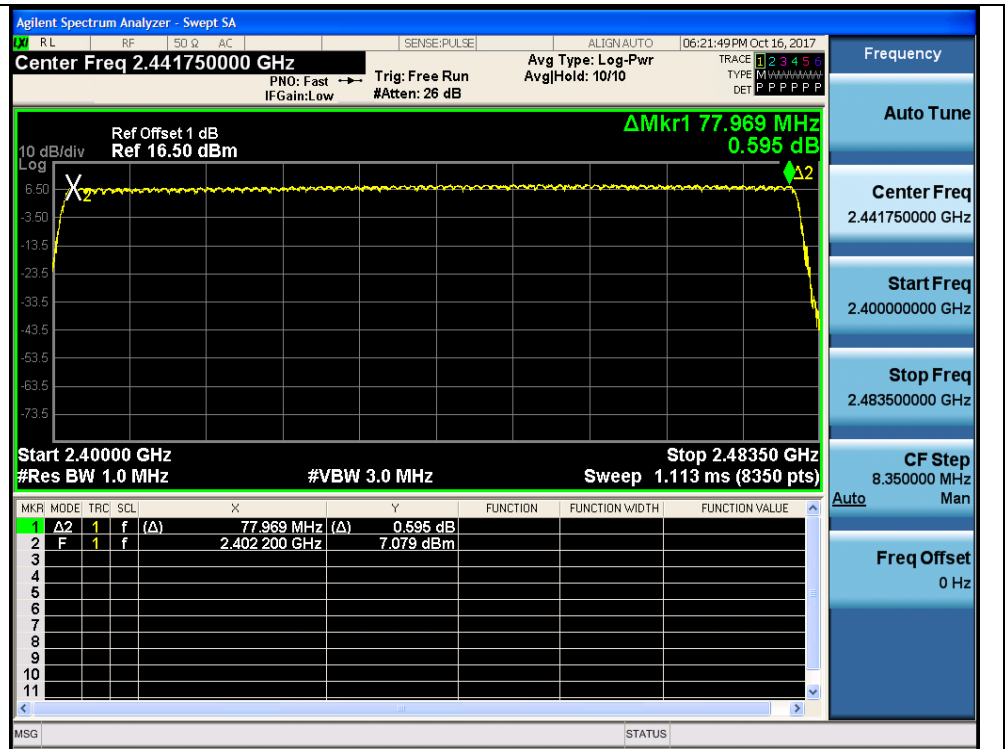

5.7. Dwell Time

LIMIT

FCC CFR Title 47 Part 15 Subpart C Section 15.247 (a)(1):The average time of occupancy on any channel shall not be greater than 0.4 seconds within a pe-riod of 0.4 seconds multiplied by the number of hopping channels employed.

TEST CONFIGURATION

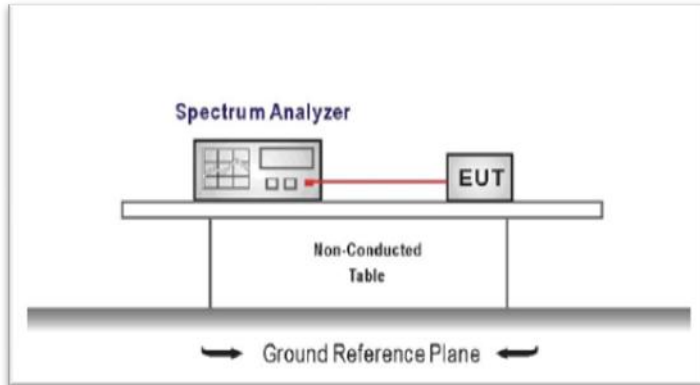

TEST PROCEDURE

1. The transmitter output was connected to the spectrum analyzer through an attenuator, the path loss was compensated to the results for each measurement.
2. Set to the maximum power setting and enable the EUT transmit continuously
3. Use the following spectrum analyzer settings:
Span = zero span, centered on a hopping channel, RBW= 1 MHz, VBW ≥ RBW
Sweep = as necessary to capture the entire dwell time per hopping channel,
Detector function = peak, Trace = max hold
4. Measure and record the results in the test report.

TEST MODE:

Please refer to the clause 3.3

TEST RESULTS

Passed Not Applicable

Modulation type	Channel	Dwell time (Second)	Limit (Second)	Result
GFSK	DH1	0.134	≤ 0.40	Pass
	DH3	0.267		
	DH5	0.312		
π/4DQPSK	2DH1	0.134	≤ 0.40	Pass
	2DH3	0.267		
	2DH5	0.313		
8DPSK	3DH1	0.134	≤ 0.40	Pass
	3DH3	0.267		
	3DH5	0.293		

Note:

1. We have tested all mode at high,middle and low channel,and recoreded worst case at middle channel.
2. Dwell time=Pulse time (ms) × (1600 ÷ 2 ÷ 79) ×31.6 Second for DH1, 2DH1, 3DH1
Dwell time=Pulse time (ms) × (1600 ÷ 4 ÷ 79) ×31.6 Second for DH3, 2DH3, 3DH3
Dwell time=Pulse time (ms) × (1600 ÷ 6 ÷ 79) ×31.6 Second for DH5, 2DH5, 3DH5

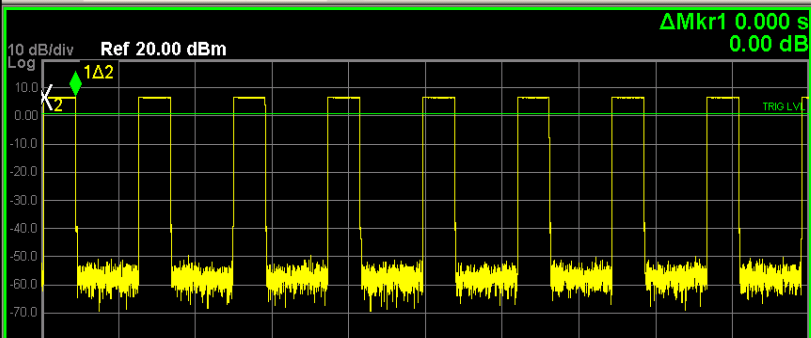
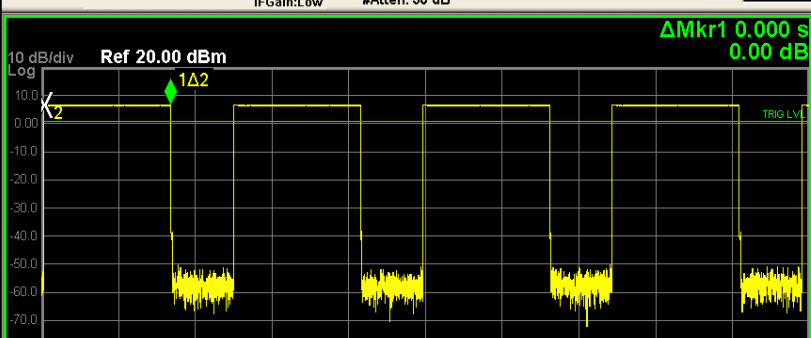
Modulation Type:	GFSK																																																																																																												
DH1	<div style="border: 1px solid black; padding: 5px;"> <p style="font-size: small; margin: 0;">Agilent Spectrum Analyzer - Swept SA</p> <p style="font-size: x-small; margin: 0;">RL RF 50 Q AC SENSE:PULSE ALIGN AUTO 06:37:06 PM Oct 16, 2017</p> <p style="font-size: small; margin: 0;">Center Freq 2.441000000 GHz Trig Delay-2.533 ms Avg Type: Log-Pwr TRACE 1 2 3 4 5 6</p> <p style="font-size: x-small; margin: 0;">PNO: Fast IFGain:Low Trig: Video #Atten: 30 dB TYPE P P P P P P P P P P P P P P P P</p>  <p style="font-size: small; margin: 0;">Center 2.441000000 GHz Res BW 1.0 MHz #VBW 3.0 MHz Sweep 10.13 ms (8001 pts) Span 0 Hz</p> <table border="1" style="width: 100%; border-collapse: collapse; font-size: x-small;"> <thead> <tr> <th>MKR</th> <th>MODE</th> <th>TRC</th> <th>SCL</th> <th>X</th> <th>Y</th> <th>FUNCTION</th> <th>FUNCTION WIDTH</th> <th>FUNCTION VALUE</th> </tr> </thead> <tbody> <tr> <td>1</td> <td>Δ2</td> <td>1</td> <td>t</td> <td>(Δ)</td> <td>0.000 s</td> <td>(Δ)</td> <td>0.00 dB</td> <td></td> </tr> <tr> <td>2</td> <td>F</td> <td>1</td> <td>t</td> <td></td> <td>31.67 μs</td> <td></td> <td>6.58 dBm</td> <td></td> </tr> <tr><td>3</td><td></td><td></td><td></td><td></td><td></td><td></td><td></td><td></td></tr> <tr><td>4</td><td></td><td></td><td></td><td></td><td></td><td></td><td></td><td></td></tr> <tr><td>5</td><td></td><td></td><td></td><td></td><td></td><td></td><td></td><td></td></tr> <tr><td>6</td><td></td><td></td><td></td><td></td><td></td><td></td><td></td><td></td></tr> <tr><td>7</td><td></td><td></td><td></td><td></td><td></td><td></td><td></td><td></td></tr> <tr><td>8</td><td></td><td></td><td></td><td></td><td></td><td></td><td></td><td></td></tr> <tr><td>9</td><td></td><td></td><td></td><td></td><td></td><td></td><td></td><td></td></tr> <tr><td>10</td><td></td><td></td><td></td><td></td><td></td><td></td><td></td><td></td></tr> <tr><td>11</td><td></td><td></td><td></td><td></td><td></td><td></td><td></td><td></td></tr> </tbody> </table> </div>	MKR	MODE	TRC	SCL	X	Y	FUNCTION	FUNCTION WIDTH	FUNCTION VALUE	1	Δ2	1	t	(Δ)	0.000 s	(Δ)	0.00 dB		2	F	1	t		31.67 μs		6.58 dBm		3									4									5									6									7									8									9									10									11								
MKR	MODE	TRC	SCL	X	Y	FUNCTION	FUNCTION WIDTH	FUNCTION VALUE																																																																																																					
1	Δ2	1	t	(Δ)	0.000 s	(Δ)	0.00 dB																																																																																																						
2	F	1	t		31.67 μs		6.58 dBm																																																																																																						
3																																																																																																													
4																																																																																																													
5																																																																																																													
6																																																																																																													
7																																																																																																													
8																																																																																																													
9																																																																																																													
10																																																																																																													
11																																																																																																													
DH3	<div style="border: 1px solid black; padding: 5px;"> <p style="font-size: small; margin: 0;">Agilent Spectrum Analyzer - Swept SA</p> <p style="font-size: x-small; margin: 0;">RL RF 50 Q AC SENSE:PULSE ALIGN AUTO 06:37:34 PM Oct 16, 2017</p> <p style="font-size: small; margin: 0;">Center Freq 2.441000000 GHz Trig Delay-2.533 ms Avg Type: Log-Pwr TRACE 1 2 3 4 5 6</p> <p style="font-size: x-small; margin: 0;">PNO: Fast IFGain:Low Trig: Video #Atten: 30 dB TYPE P P P P P P P P P P P P P P P P</p>  <p style="font-size: small; margin: 0;">Center 2.441000000 GHz Res BW 1.0 MHz #VBW 3.0 MHz Sweep 10.13 ms (8001 pts) Span 0 Hz</p> <table border="1" style="width: 100%; border-collapse: collapse; font-size: x-small;"> <thead> <tr> <th>MKR</th> <th>MODE</th> <th>TRC</th> <th>SCL</th> <th>X</th> <th>Y</th> <th>FUNCTION</th> <th>FUNCTION WIDTH</th> <th>FUNCTION VALUE</th> </tr> </thead> <tbody> <tr> <td>1</td> <td>Δ2</td> <td>1</td> <td>t</td> <td>(Δ)</td> <td>0.000 s</td> <td>(Δ)</td> <td>0.00 dB</td> <td></td> </tr> <tr> <td>2</td> <td>F</td> <td>1</td> <td>t</td> <td></td> <td>31.67 μs</td> <td></td> <td>6.57 dBm</td> <td></td> </tr> <tr><td>3</td><td></td><td></td><td></td><td></td><td></td><td></td><td></td><td></td></tr> <tr><td>4</td><td></td><td></td><td></td><td></td><td></td><td></td><td></td><td></td></tr> <tr><td>5</td><td></td><td></td><td></td><td></td><td></td><td></td><td></td><td></td></tr> <tr><td>6</td><td></td><td></td><td></td><td></td><td></td><td></td><td></td><td></td></tr> <tr><td>7</td><td></td><td></td><td></td><td></td><td></td><td></td><td></td><td></td></tr> <tr><td>8</td><td></td><td></td><td></td><td></td><td></td><td></td><td></td><td></td></tr> <tr><td>9</td><td></td><td></td><td></td><td></td><td></td><td></td><td></td><td></td></tr> <tr><td>10</td><td></td><td></td><td></td><td></td><td></td><td></td><td></td><td></td></tr> <tr><td>11</td><td></td><td></td><td></td><td></td><td></td><td></td><td></td><td></td></tr> </tbody> </table> </div>	MKR	MODE	TRC	SCL	X	Y	FUNCTION	FUNCTION WIDTH	FUNCTION VALUE	1	Δ2	1	t	(Δ)	0.000 s	(Δ)	0.00 dB		2	F	1	t		31.67 μs		6.57 dBm		3									4									5									6									7									8									9									10									11								
MKR	MODE	TRC	SCL	X	Y	FUNCTION	FUNCTION WIDTH	FUNCTION VALUE																																																																																																					
1	Δ2	1	t	(Δ)	0.000 s	(Δ)	0.00 dB																																																																																																						
2	F	1	t		31.67 μs		6.57 dBm																																																																																																						
3																																																																																																													
4																																																																																																													
5																																																																																																													
6																																																																																																													
7																																																																																																													
8																																																																																																													
9																																																																																																													
10																																																																																																													
11																																																																																																													

DH5

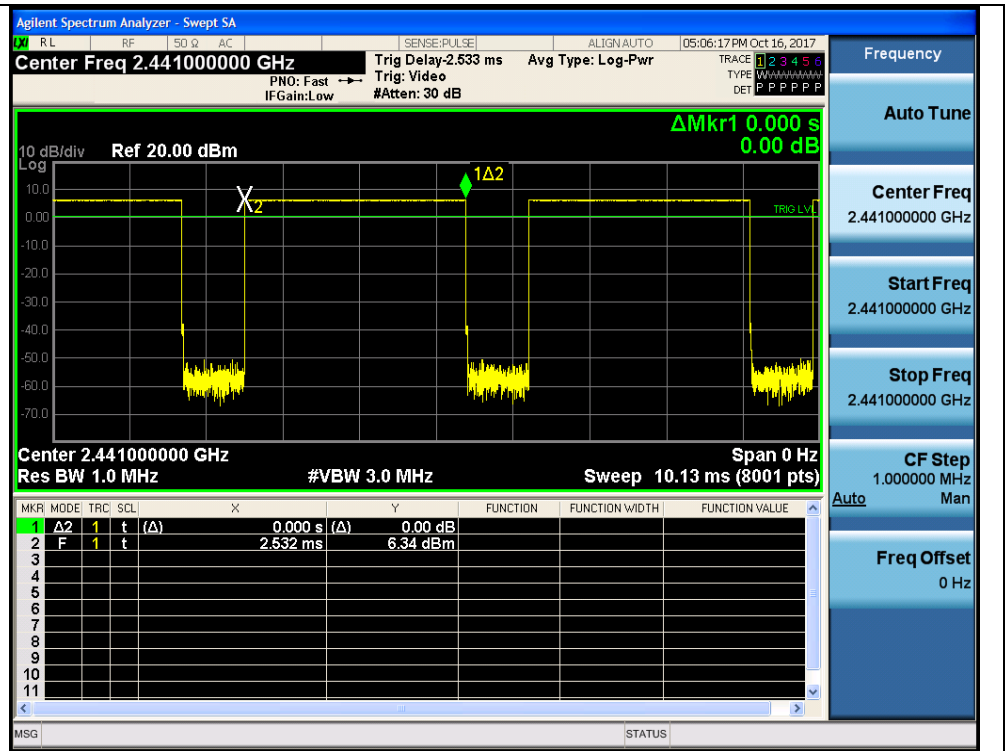

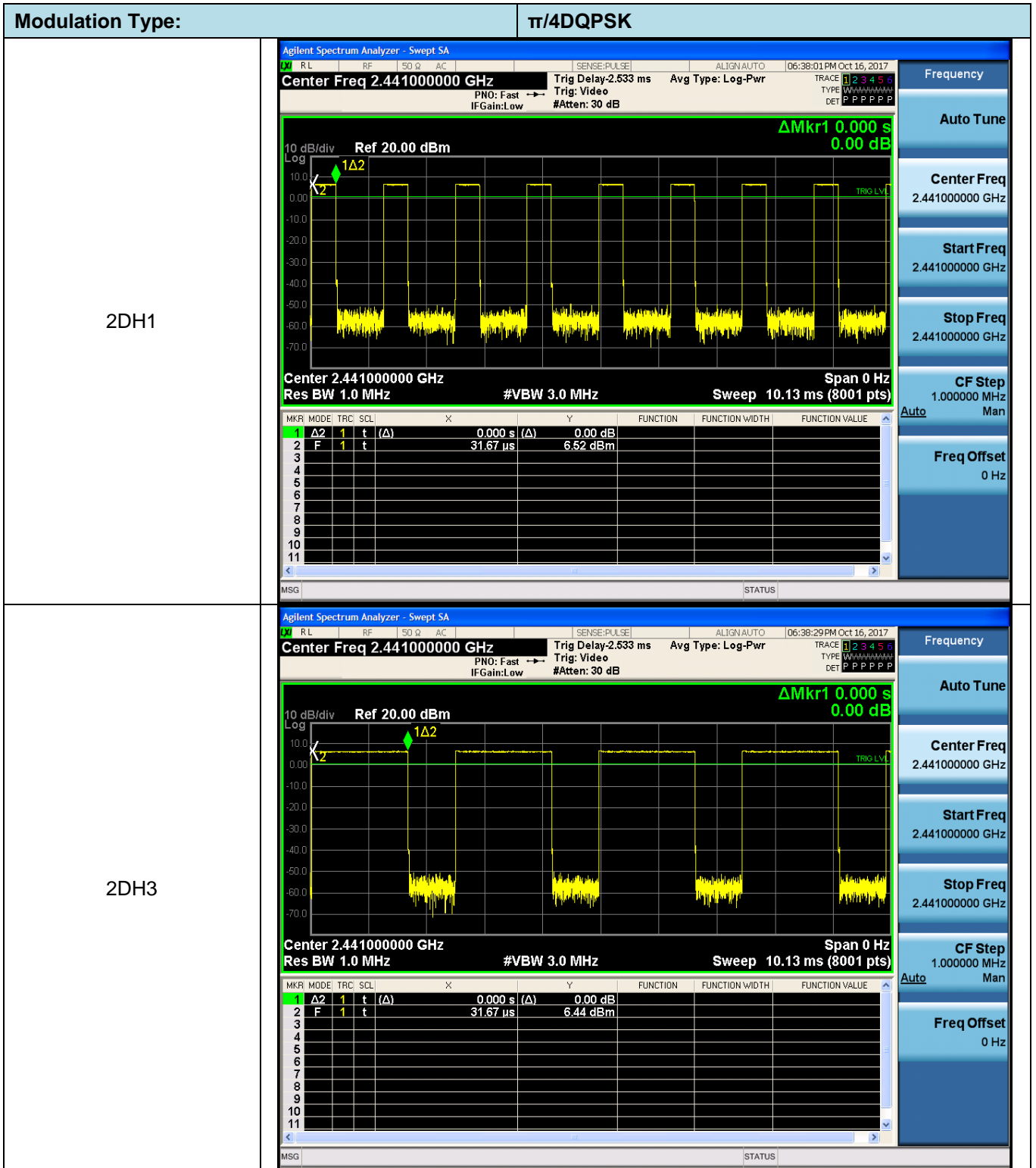

2DH5

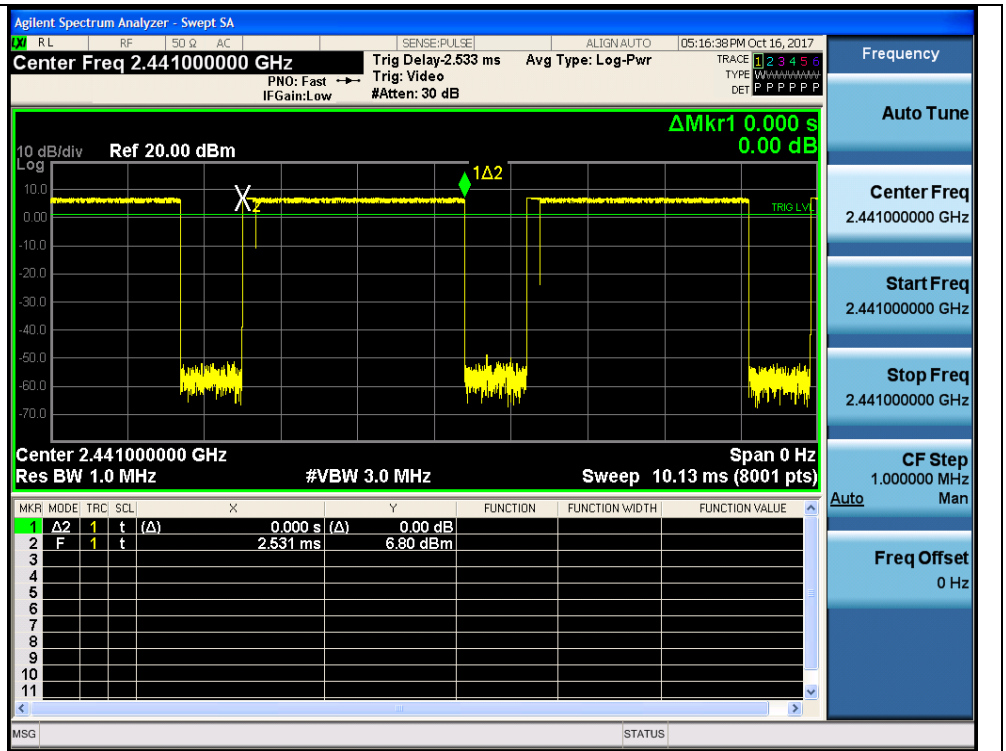

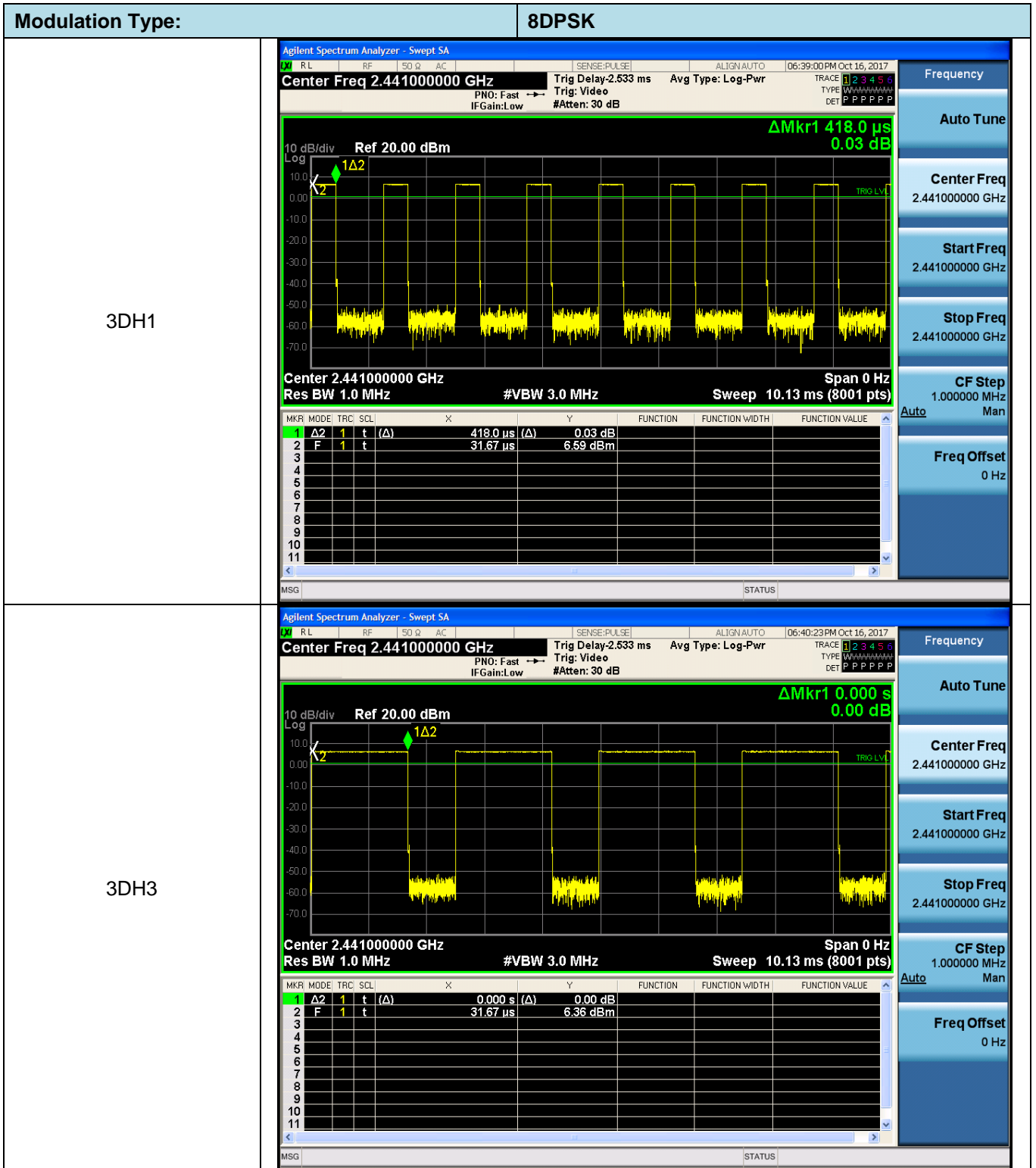

3DH5

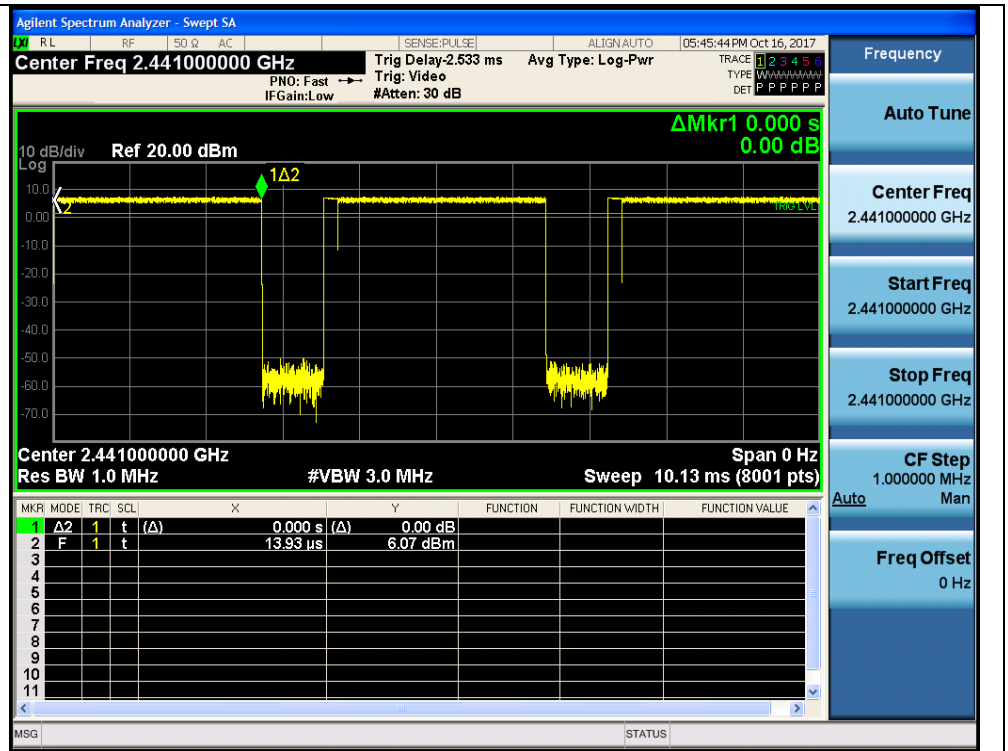

5.8. Pseudorandom Frequency Hopping Sequence

LIMIT

FCC CFR Title 47 Part 15 Subpart C Section 15.247 (a)(1):Frequency hopping systems shall have hopping channel carrier frequencies separated by a minimum of 25 kHz or the 20 dB bandwidth of the hopping channel, whichever is greater. Alternatively, frequency hopping systems operating in the 2400–2483.5 MHz band may have hopping channel carrier frequencies that are separated by 25 kHz or two-thirds of the 20 dB bandwidth of the hopping channel, whichever is greater, provided the systems operate with an output power no greater than 125 mW. The system shall hop to channel frequencies that are selected at the system hopping rate from a pseudo-randomly ordered list of hopping frequencies. Each frequency must be used equally on the average by each transmitter. The system receivers shall have input bandwidths that match the hopping channel bandwidths of their corresponding transmitters and shall shift frequencies in synchronization with the transmitted signals.

TEST RESULTS

The pseudorandom frequency hopping sequence may be generated in a nine-stage shift register whose 5th and 9th stage outputs are added in a modulo-two addition stage. And the result is fed back to the input of the first stage. The sequence begins with the first one of 9 consecutive ones, for example: the shift register is initialized with nine ones.

- Number of shift register stages: 9
- Length of pseudo-random sequence: $2^9 - 1 = 511$ bits
- Longest sequence of zeros: 8 (non-inverted signal)

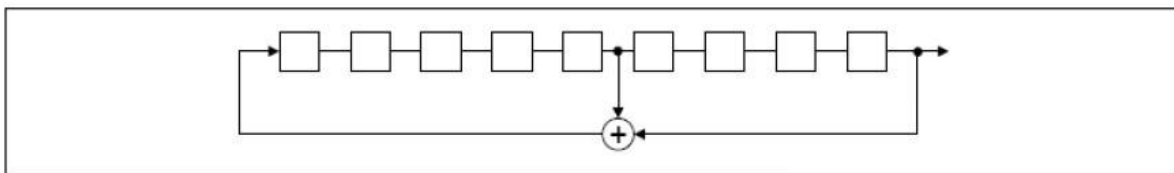

Linear Feedback Shift Register for Generation of the PRBS sequence

An example of pseudorandom frequency hopping sequence as follows:

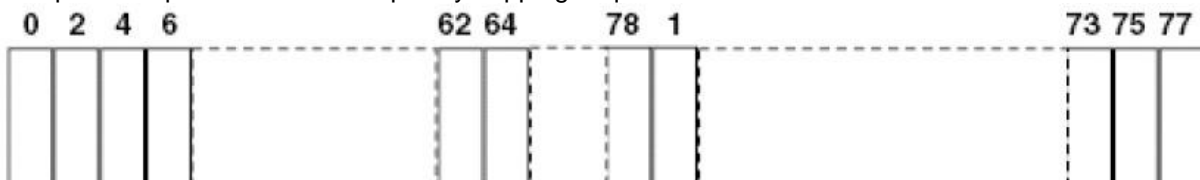

Each frequency used equally on the average by each transmitter. The system receiver has input bandwidths that match the hopping channel bandwidths of their corresponding transmitter and shift frequencies in synchronization with the transmitted signals.

5.9. Restricted band (radiated)

LIMIT

FCC CFR Title 47 Part 15 Subpart C Section 15.247 (d):

In any 100 kHz bandwidth outside the frequency band in which the spread spectrum or digitally modulated intentional radiator is operating, Radiated Emissions which fall in the restricted bands, as defined in §15.205(a), must also comply with the Radiated Emissions limits specified in §15.209(a) (see §15.205(c)).

TEST CONFIGURATION

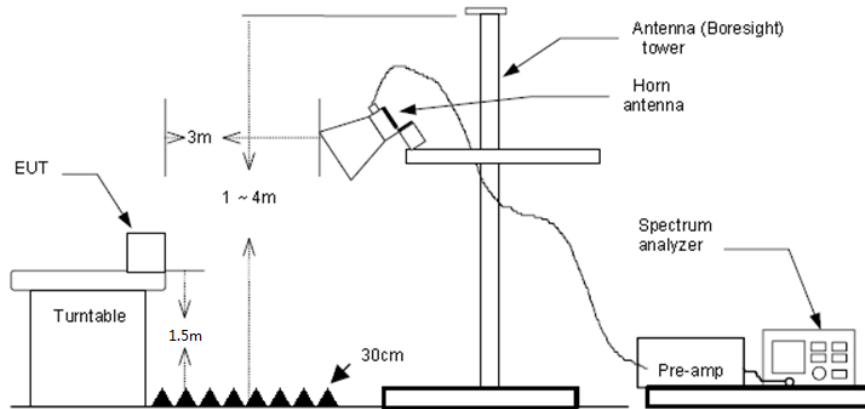

TEST PROCEDURE

1. The EUT was setup and tested according to ANSI C63.10:2013 for compliance to FCC 47CFR 15.247 requirements.
2. The EUT is placed on a turn table which is 1.5 meter above ground. The turn table is rotated 360 degrees to determine the position of the maximum emission level.
3. The EUT was positioned such that the distance from antenna to the EUT was 3 meters.
4. The antenna is scanned from 1 meter to 4 meters to find out the maximum emission level. This is repeated for both horizontal and vertical polarization of the antenna. In order to find the maximum emission, all of the interface cables were manipulated according to ANSI C63.10:2013 on radiated measurement.
5. The receiver set as follow:
 RBW=1 MHz, VBW=3 MHz Peak detector for Peak value
 RBW=1 MHz, VBW=10 Hz Peak detector for Average value.

TEST MODE:

Please refer to the clause 3.3

TEST RESULTS

Passed Not Applicable

Note:

- 1) Final level= Read level + Antenna Factor+ Cable Loss- Preamp Factor
- 2) Have pre-scan all modulation mode, found the GFSK modulation which it was worst case, so only the worst case's data on the test report.
- 3) The peak level is lower than average limit(54 dBuV/m), this data is the too weak instrument of signal is unable to test.

CH00									
Frequency (MHz)	Read Level (dBUV)	Antenna Factor (dB/m)	Cable Loss (dB)	Preamp Factor (dB)	Level (dBUV/m)	Limit Line (dBUV/m)	Over Limit (dB)	Polarization	Test value
2310.00	34.79	28.05	6.62	37.65	31.81	74.00	-42.19	Horizontal	Peak
2390.03	41.49	27.65	6.75	37.87	38.02	74.00	-35.98	Horizontal	Peak
2310.00	34.81	28.05	6.62	37.65	31.83	74.00	-42.17	Vertical	Peak
2390.03	35.33	27.65	6.75	37.87	31.86	74.00	-42.14	Vertical	Peak
2310.00	23.58	28.05	6.62	37.65	20.60	54.00	-33.40	Horizontal	Average
2390.03	23.24	27.65	6.75	37.87	19.77	54.00	-34.23	Horizontal	Average
2310.00	23.56	28.05	6.62	37.65	20.58	54.00	-33.42	Vertical	Average
2390.03	23.27	27.65	6.75	37.87	19.80	54.00	-34.20	Vertical	Average

CH78									
Frequency (MHz)	Read Level (dBUV)	Antenna Factor (dB/m)	Cable Loss (dB)	Preamp Factor (dB)	Level (dBUV/m)	Limit Line (dBUV/m)	Over Limit (dB)	Polarization	Test value
2483.50	54.57	27.26	6.83	37.87	50.79	74.00	-23.21	Horizontal	Peak
2495.58	55.72	27.22	6.84	37.87	51.91	74.00	-22.09	Horizontal	Peak
2500.00	36.51	27.20	6.84	37.87	32.68	74.00	-41.32	Horizontal	Peak
2483.50	59.67	27.26	6.83	37.87	55.89	74.00	-18.11	Vertical	Peak
2495.13	60.85	27.22	6.84	37.87	57.04	74.00	-16.96	Vertical	Peak
2500.00	43.29	27.20	6.84	37.87	39.46	74.00	-34.54	Vertical	Peak
2483.50	30.11	27.26	6.83	37.87	26.33	54.00	-27.67	Horizontal	Average
2500.00	22.55	27.20	6.84	37.87	18.72	54.00	-35.28	Horizontal	Average
2483.50	32.43	27.26	6.83	37.87	28.65	54.00	-25.35	Vertical	Average
2500.00	22.78	27.20	6.84	37.87	18.95	54.00	-35.05	Vertical	Average

5.10. Band edge and Spurious Emissions (conducted)

LIMIT

FCC CFR Title 47 Part 15 Subpart C Section 15.247 (d): In any 100 kHz bandwidth outside the frequency band in which the spread spectrum intentional radiator is operating, the radio frequency power that is produced by the intentional radiator shall be at least 20 dB below that in the 100 kHz bandwidth within the band that contains the highest level of the desired power, based on either an RF conducted or a radiated measurement.

TEST CONFIGURATION

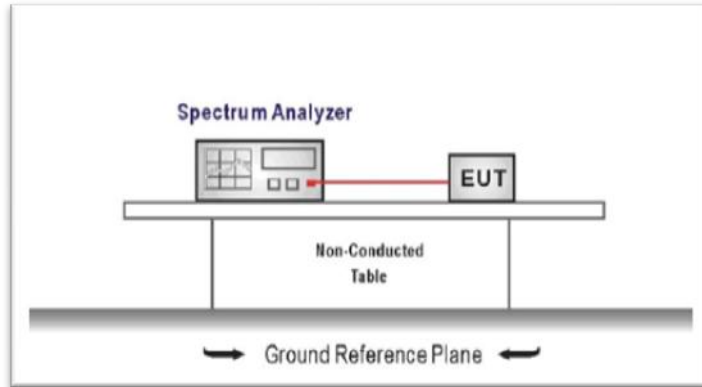

TEST PROCEDURE

1. The transmitter output was connected to the spectrum analyzer through an attenuator, the path loss was compensated to the results for each measurement.
2. Set to the maximum power setting and enable the EUT transmit continuously
3. Use the following spectrum analyzer settings:
RBW = 100 kHz, VBW \geq RBW
Sweep = auto, Detector function = peak, Trace = max hold
4. Measure and record the results in the test report.

TEST MODE:

Please refer to the clause 3.3

TEST RESULTS

Passed Not Applicable

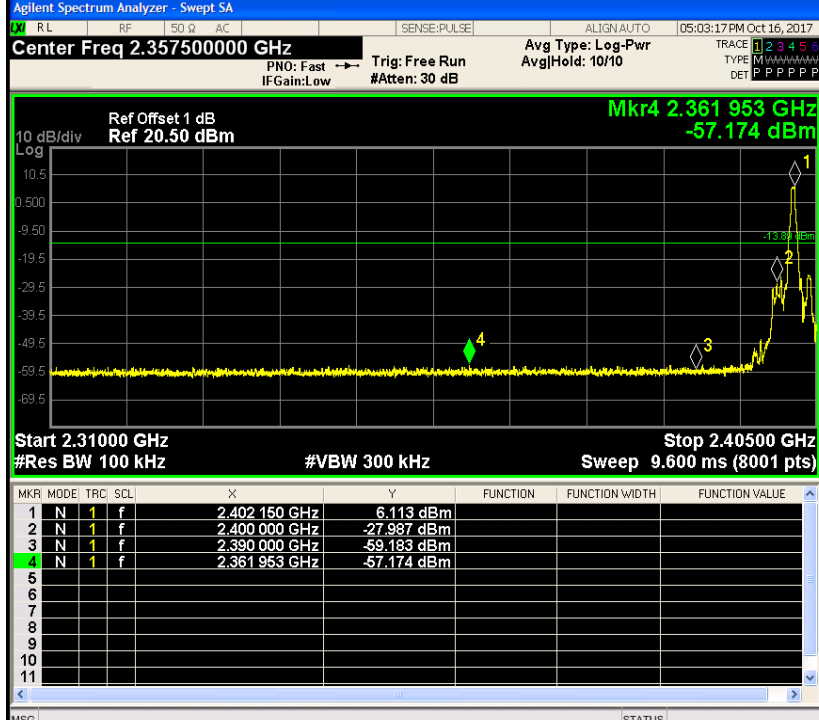
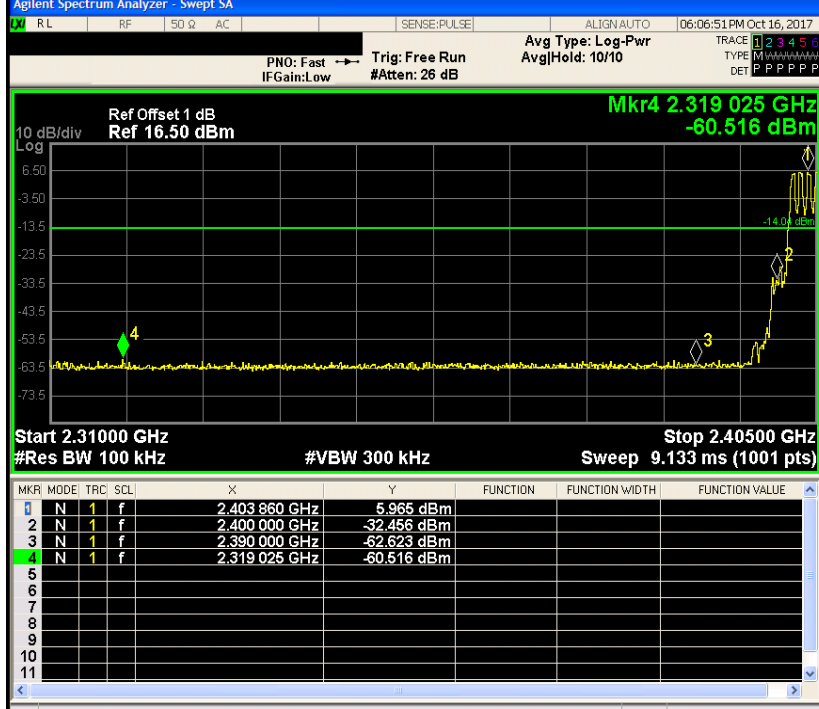
Test Item:	Band edge	Modulation type:	GFSK																																													
<p>CH00 No hopping mode</p>	 <p>Agilent Spectrum Analyzer - Swept SA</p> <p>Center Freq 2.35750000 GHz</p> <p>Ref Offset 1 dB Ref 20.50 dBm</p> <p>Mkr4 2.361 953 GHz -57.174 dBm</p> <table border="1"> <thead> <tr> <th>MKR</th> <th>MODE</th> <th>TRC</th> <th>SCL</th> <th>X</th> <th>Y</th> <th>FUNCTION</th> <th>FUNCTION WIDTH</th> <th>FUNCTION VALUE</th> </tr> </thead> <tbody> <tr> <td>1</td> <td>N</td> <td>1</td> <td>f</td> <td>2.402 150 GHz</td> <td>6.113 dBm</td> <td></td> <td></td> <td></td> </tr> <tr> <td>2</td> <td>N</td> <td>1</td> <td>f</td> <td>2.400 000 GHz</td> <td>-27.987 dBm</td> <td></td> <td></td> <td></td> </tr> <tr> <td>3</td> <td>N</td> <td>1</td> <td>f</td> <td>2.390 000 GHz</td> <td>-59.183 dBm</td> <td></td> <td></td> <td></td> </tr> <tr> <td>4</td> <td>N</td> <td>1</td> <td>f</td> <td>2.361 953 GHz</td> <td>-57.174 dBm</td> <td></td> <td></td> <td></td> </tr> </tbody> </table>			MKR	MODE	TRC	SCL	X	Y	FUNCTION	FUNCTION WIDTH	FUNCTION VALUE	1	N	1	f	2.402 150 GHz	6.113 dBm				2	N	1	f	2.400 000 GHz	-27.987 dBm				3	N	1	f	2.390 000 GHz	-59.183 dBm				4	N	1	f	2.361 953 GHz	-57.174 dBm			
MKR	MODE	TRC	SCL	X	Y	FUNCTION	FUNCTION WIDTH	FUNCTION VALUE																																								
1	N	1	f	2.402 150 GHz	6.113 dBm																																											
2	N	1	f	2.400 000 GHz	-27.987 dBm																																											
3	N	1	f	2.390 000 GHz	-59.183 dBm																																											
4	N	1	f	2.361 953 GHz	-57.174 dBm																																											
<p>CH00 Hopping mode</p>	 <p>Agilent Spectrum Analyzer - Swept SA</p> <p>Center Freq 2.319025 GHz</p> <p>Ref Offset 1 dB Ref 16.50 dBm</p> <p>Mkr4 2.319 025 GHz -60.516 dBm</p> <table border="1"> <thead> <tr> <th>MKR</th> <th>MODE</th> <th>TRC</th> <th>SCL</th> <th>X</th> <th>Y</th> <th>FUNCTION</th> <th>FUNCTION WIDTH</th> <th>FUNCTION VALUE</th> </tr> </thead> <tbody> <tr> <td>1</td> <td>N</td> <td>1</td> <td>f</td> <td>2.403 860 GHz</td> <td>5.965 dBm</td> <td></td> <td></td> <td></td> </tr> <tr> <td>2</td> <td>N</td> <td>1</td> <td>f</td> <td>2.400 000 GHz</td> <td>-32.456 dBm</td> <td></td> <td></td> <td></td> </tr> <tr> <td>3</td> <td>N</td> <td>1</td> <td>f</td> <td>2.390 000 GHz</td> <td>-62.623 dBm</td> <td></td> <td></td> <td></td> </tr> <tr> <td>4</td> <td>N</td> <td>1</td> <td>f</td> <td>2.319 025 GHz</td> <td>-60.516 dBm</td> <td></td> <td></td> <td></td> </tr> </tbody> </table>			MKR	MODE	TRC	SCL	X	Y	FUNCTION	FUNCTION WIDTH	FUNCTION VALUE	1	N	1	f	2.403 860 GHz	5.965 dBm				2	N	1	f	2.400 000 GHz	-32.456 dBm				3	N	1	f	2.390 000 GHz	-62.623 dBm				4	N	1	f	2.319 025 GHz	-60.516 dBm			
MKR	MODE	TRC	SCL	X	Y	FUNCTION	FUNCTION WIDTH	FUNCTION VALUE																																								
1	N	1	f	2.403 860 GHz	5.965 dBm																																											
2	N	1	f	2.400 000 GHz	-32.456 dBm																																											
3	N	1	f	2.390 000 GHz	-62.623 dBm																																											
4	N	1	f	2.319 025 GHz	-60.516 dBm																																											

CH78
No hopping mode

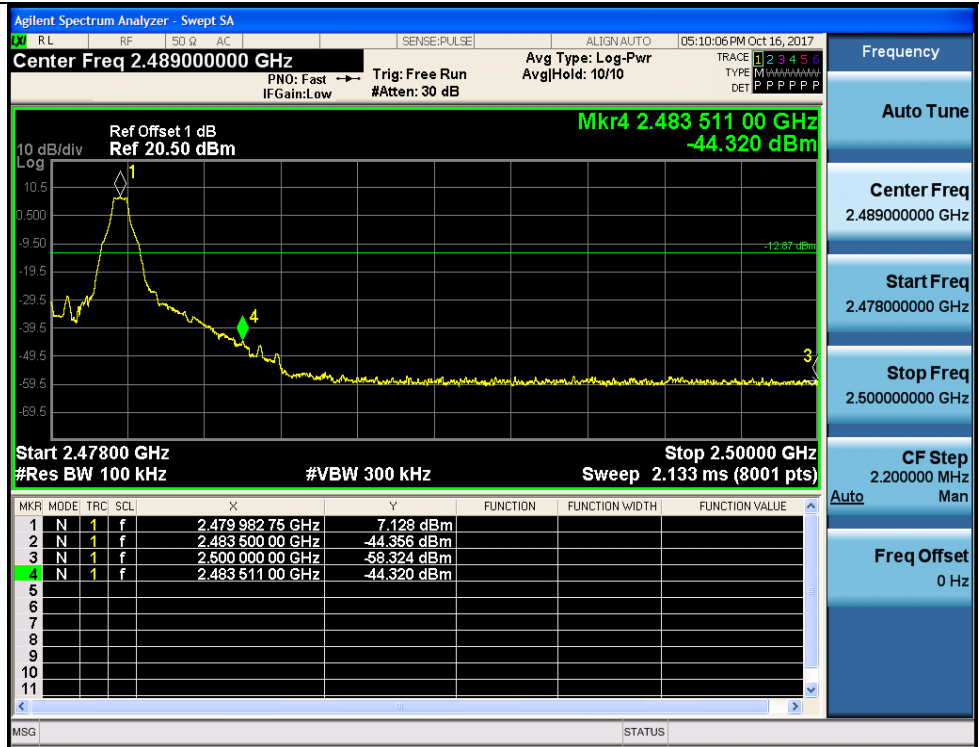

CH78
Hopping mode



Test Item:	Band edge	Modulation type:	$\pi/4$ DQPSK																																													
<p>CH00</p> <p>No hopping mode</p>	<p>Agilent Spectrum Analyzer - Swept SA</p> <p>Center Freq 2.357500000 GHz</p> <p>Ref Offset 1 dB Ref 20.50 dBm</p> <p>Mkr4 2.360 219 GHz -57.206 dBm</p> <p>Start 2.31000 GHz #Res BW 100 kHz</p> <p>#VBW 300 kHz</p> <p>Stop 2.40500 GHz Sweep 9.600 ms (8001 pts)</p> <table border="1"> <thead> <tr> <th>MKR</th> <th>MODE</th> <th>TRC</th> <th>SCL</th> <th>X</th> <th>Y</th> <th>FUNCTION</th> <th>FUNCTION WIDTH</th> <th>FUNCTION VALUE</th> </tr> </thead> <tbody> <tr> <td>1</td> <td>N</td> <td>1</td> <td>f</td> <td>2.401 996 GHz</td> <td>6.986 dBm</td> <td></td> <td></td> <td></td> </tr> <tr> <td>2</td> <td>N</td> <td>1</td> <td>f</td> <td>2.400 000 GHz</td> <td>-24.326 dBm</td> <td></td> <td></td> <td></td> </tr> <tr> <td>3</td> <td>N</td> <td>1</td> <td>f</td> <td>2.390 000 GHz</td> <td>-58.943 dBm</td> <td></td> <td></td> <td></td> </tr> <tr> <td>4</td> <td>N</td> <td>1</td> <td>f</td> <td>2.360 219 GHz</td> <td>-57.206 dBm</td> <td></td> <td></td> <td></td> </tr> </tbody> </table>			MKR	MODE	TRC	SCL	X	Y	FUNCTION	FUNCTION WIDTH	FUNCTION VALUE	1	N	1	f	2.401 996 GHz	6.986 dBm				2	N	1	f	2.400 000 GHz	-24.326 dBm				3	N	1	f	2.390 000 GHz	-58.943 dBm				4	N	1	f	2.360 219 GHz	-57.206 dBm			
MKR	MODE	TRC	SCL	X	Y	FUNCTION	FUNCTION WIDTH	FUNCTION VALUE																																								
1	N	1	f	2.401 996 GHz	6.986 dBm																																											
2	N	1	f	2.400 000 GHz	-24.326 dBm																																											
3	N	1	f	2.390 000 GHz	-58.943 dBm																																											
4	N	1	f	2.360 219 GHz	-57.206 dBm																																											
<p>CH00</p> <p>Hopping mode</p>	<p>Agilent Spectrum Analyzer - Swept SA</p> <p>Marker 1 2.401960000000 GHz</p> <p>Ref Offset 1 dB Ref 16.50 dBm</p> <p>Mkr4 2.378 590 GHz -60.454 dBm</p> <p>Start 2.31000 GHz #Res BW 100 kHz</p> <p>#VBW 300 kHz</p> <p>Stop 2.40500 GHz Sweep 9.133 ms (1001 pts)</p> <table border="1"> <thead> <tr> <th>MKR</th> <th>MODE</th> <th>TRC</th> <th>SCL</th> <th>X</th> <th>Y</th> <th>FUNCTION</th> <th>FUNCTION WIDTH</th> <th>FUNCTION VALUE</th> </tr> </thead> <tbody> <tr> <td>1</td> <td>N</td> <td>1</td> <td>f</td> <td>2.401 960 GHz</td> <td>6.692 dBm</td> <td></td> <td></td> <td></td> </tr> <tr> <td>2</td> <td>N</td> <td>1</td> <td>f</td> <td>2.400 000 GHz</td> <td>-24.581 dBm</td> <td></td> <td></td> <td></td> </tr> <tr> <td>3</td> <td>N</td> <td>1</td> <td>f</td> <td>2.390 000 GHz</td> <td>-63.186 dBm</td> <td></td> <td></td> <td></td> </tr> <tr> <td>4</td> <td>N</td> <td>1</td> <td>f</td> <td>2.378 590 GHz</td> <td>-60.454 dBm</td> <td></td> <td></td> <td></td> </tr> </tbody> </table>			MKR	MODE	TRC	SCL	X	Y	FUNCTION	FUNCTION WIDTH	FUNCTION VALUE	1	N	1	f	2.401 960 GHz	6.692 dBm				2	N	1	f	2.400 000 GHz	-24.581 dBm				3	N	1	f	2.390 000 GHz	-63.186 dBm				4	N	1	f	2.378 590 GHz	-60.454 dBm			
MKR	MODE	TRC	SCL	X	Y	FUNCTION	FUNCTION WIDTH	FUNCTION VALUE																																								
1	N	1	f	2.401 960 GHz	6.692 dBm																																											
2	N	1	f	2.400 000 GHz	-24.581 dBm																																											
3	N	1	f	2.390 000 GHz	-63.186 dBm																																											
4	N	1	f	2.378 590 GHz	-60.454 dBm																																											

<p>CH78 No hopping mode</p>	<p>Agilent Spectrum Analyzer - Swept SA</p> <p>Center Freq 2.489000000 GHz</p> <p>Ref Offset 1 dB Ref 20.50 dBm</p> <p>Mkr4 2.483 511 00 GHz -42.630 dBm</p> <p>Start 2.47800 GHz #Res BW 100 kHz</p> <p>Stop 2.50000 GHz #VBW 300 kHz Sweep 2.133 ms (8001 pts)</p> <table border="1"> <thead> <tr> <th>MKR</th> <th>MODE</th> <th>TRC</th> <th>SCL</th> <th>X</th> <th>Y</th> <th>FUNCTION</th> <th>FUNCTION WIDTH</th> <th>FUNCTION VALUE</th> </tr> </thead> <tbody> <tr> <td>1</td> <td>N</td> <td>1</td> <td>f</td> <td>2.479 985 50 GHz</td> <td>7.719 dBm</td> <td></td> <td></td> <td></td> </tr> <tr> <td>2</td> <td>N</td> <td>1</td> <td>f</td> <td>2.483 500 00 GHz</td> <td>-42.725 dBm</td> <td></td> <td></td> <td></td> </tr> <tr> <td>3</td> <td>N</td> <td>1</td> <td>f</td> <td>2.500 000 00 GHz</td> <td>-59.465 dBm</td> <td></td> <td></td> <td></td> </tr> <tr> <td>4</td> <td>N</td> <td>1</td> <td>f</td> <td>2.483 511 00 GHz</td> <td>-42.630 dBm</td> <td></td> <td></td> <td></td> </tr> </tbody> </table>	MKR	MODE	TRC	SCL	X	Y	FUNCTION	FUNCTION WIDTH	FUNCTION VALUE	1	N	1	f	2.479 985 50 GHz	7.719 dBm				2	N	1	f	2.483 500 00 GHz	-42.725 dBm				3	N	1	f	2.500 000 00 GHz	-59.465 dBm				4	N	1	f	2.483 511 00 GHz	-42.630 dBm			
MKR	MODE	TRC	SCL	X	Y	FUNCTION	FUNCTION WIDTH	FUNCTION VALUE																																						
1	N	1	f	2.479 985 50 GHz	7.719 dBm																																									
2	N	1	f	2.483 500 00 GHz	-42.725 dBm																																									
3	N	1	f	2.500 000 00 GHz	-59.465 dBm																																									
4	N	1	f	2.483 511 00 GHz	-42.630 dBm																																									
<p>CH78 Hopping mode</p>	<p>Agilent Spectrum Analyzer - Swept SA</p> <p>Marker 1 2.478000000000 GHz</p> <p>Ref Offset 1 dB Ref 16.50 dBm</p> <p>Mkr4 2.483 522 GHz -43.342 dBm</p> <p>Start 2.47800 GHz #Res BW 100 kHz</p> <p>Stop 2.50000 GHz #VBW 300 kHz Sweep 2.133 ms (1001 pts)</p> <table border="1"> <thead> <tr> <th>MKR</th> <th>MODE</th> <th>TRC</th> <th>SCL</th> <th>X</th> <th>Y</th> <th>FUNCTION</th> <th>FUNCTION WIDTH</th> <th>FUNCTION VALUE</th> </tr> </thead> <tbody> <tr> <td>1</td> <td>N</td> <td>1</td> <td>f</td> <td>2.478 000 GHz</td> <td>7.640 dBm</td> <td></td> <td></td> <td></td> </tr> <tr> <td>2</td> <td>N</td> <td>1</td> <td>f</td> <td>2.483 500 GHz</td> <td>-43.344 dBm</td> <td></td> <td></td> <td></td> </tr> <tr> <td>3</td> <td>N</td> <td>1</td> <td>f</td> <td>2.500 000 GHz</td> <td>-61.497 dBm</td> <td></td> <td></td> <td></td> </tr> <tr> <td>4</td> <td>N</td> <td>1</td> <td>f</td> <td>2.483 522 GHz</td> <td>-43.342 dBm</td> <td></td> <td></td> <td></td> </tr> </tbody> </table>	MKR	MODE	TRC	SCL	X	Y	FUNCTION	FUNCTION WIDTH	FUNCTION VALUE	1	N	1	f	2.478 000 GHz	7.640 dBm				2	N	1	f	2.483 500 GHz	-43.344 dBm				3	N	1	f	2.500 000 GHz	-61.497 dBm				4	N	1	f	2.483 522 GHz	-43.342 dBm			
MKR	MODE	TRC	SCL	X	Y	FUNCTION	FUNCTION WIDTH	FUNCTION VALUE																																						
1	N	1	f	2.478 000 GHz	7.640 dBm																																									
2	N	1	f	2.483 500 GHz	-43.344 dBm																																									
3	N	1	f	2.500 000 GHz	-61.497 dBm																																									
4	N	1	f	2.483 522 GHz	-43.342 dBm																																									

Test Item:	Band edge	Modulation type:	8DPSK																																													
<p>CH00 No hopping mode</p>	<p>Agilent Spectrum Analyzer - Swept SA</p> <p>Center Freq 2.357500000 GHz</p> <p>Ref Offset 1 dB Ref 20.50 dBm</p> <p>Mkr4 2.387 912 GHz -57.083 dBm</p> <p>Start 2.31000 GHz #Res BW 100 kHz</p> <p>Stop 2.40500 GHz #VBW 300 kHz Sweep 9.600 ms (8001 pts)</p> <table border="1"> <thead> <tr> <th>MKR</th> <th>MODE</th> <th>TRC</th> <th>SCL</th> <th>X</th> <th>Y</th> <th>FUNCTION</th> <th>FUNCTION WIDTH</th> <th>FUNCTION VALUE</th> </tr> </thead> <tbody> <tr> <td>1</td> <td>N</td> <td>1</td> <td>f</td> <td>2.401 984 GHz</td> <td>7.103 dBm</td> <td></td> <td></td> <td></td> </tr> <tr> <td>2</td> <td>N</td> <td>1</td> <td>f</td> <td>2.400 000 GHz</td> <td>-24.213 dBm</td> <td></td> <td></td> <td></td> </tr> <tr> <td>3</td> <td>N</td> <td>1</td> <td>f</td> <td>2.390 000 GHz</td> <td>-59.690 dBm</td> <td></td> <td></td> <td></td> </tr> <tr> <td>4</td> <td>N</td> <td>1</td> <td>f</td> <td>2.387 912 GHz</td> <td>-57.083 dBm</td> <td></td> <td></td> <td></td> </tr> </tbody> </table>			MKR	MODE	TRC	SCL	X	Y	FUNCTION	FUNCTION WIDTH	FUNCTION VALUE	1	N	1	f	2.401 984 GHz	7.103 dBm				2	N	1	f	2.400 000 GHz	-24.213 dBm				3	N	1	f	2.390 000 GHz	-59.690 dBm				4	N	1	f	2.387 912 GHz	-57.083 dBm			
MKR	MODE	TRC	SCL	X	Y	FUNCTION	FUNCTION WIDTH	FUNCTION VALUE																																								
1	N	1	f	2.401 984 GHz	7.103 dBm																																											
2	N	1	f	2.400 000 GHz	-24.213 dBm																																											
3	N	1	f	2.390 000 GHz	-59.690 dBm																																											
4	N	1	f	2.387 912 GHz	-57.083 dBm																																											
<p>CH00 Hopping mode</p>	<p>Agilent Spectrum Analyzer - Swept SA</p> <p>Marker 1 2.405000000000 GHz</p> <p>Ref Offset 1 dB Ref 16.50 dBm</p> <p>Mkr4 2.387 045 GHz -60.017 dBm</p> <p>Start 2.31000 GHz #Res BW 100 kHz</p> <p>Stop 2.40500 GHz #VBW 300 kHz Sweep 9.133 ms (1001 pts)</p> <table border="1"> <thead> <tr> <th>MKR</th> <th>MODE</th> <th>TRC</th> <th>SCL</th> <th>X</th> <th>Y</th> <th>FUNCTION</th> <th>FUNCTION WIDTH</th> <th>FUNCTION VALUE</th> </tr> </thead> <tbody> <tr> <td>1</td> <td>N</td> <td>1</td> <td>f</td> <td>2.405 000 GHz</td> <td>6.918 dBm</td> <td></td> <td></td> <td></td> </tr> <tr> <td>2</td> <td>N</td> <td>1</td> <td>f</td> <td>2.400 000 GHz</td> <td>-24.317 dBm</td> <td></td> <td></td> <td></td> </tr> <tr> <td>3</td> <td>N</td> <td>1</td> <td>f</td> <td>2.390 000 GHz</td> <td>-62.160 dBm</td> <td></td> <td></td> <td></td> </tr> <tr> <td>4</td> <td>N</td> <td>1</td> <td>f</td> <td>2.387 045 GHz</td> <td>-60.017 dBm</td> <td></td> <td></td> <td></td> </tr> </tbody> </table>			MKR	MODE	TRC	SCL	X	Y	FUNCTION	FUNCTION WIDTH	FUNCTION VALUE	1	N	1	f	2.405 000 GHz	6.918 dBm				2	N	1	f	2.400 000 GHz	-24.317 dBm				3	N	1	f	2.390 000 GHz	-62.160 dBm				4	N	1	f	2.387 045 GHz	-60.017 dBm			
MKR	MODE	TRC	SCL	X	Y	FUNCTION	FUNCTION WIDTH	FUNCTION VALUE																																								
1	N	1	f	2.405 000 GHz	6.918 dBm																																											
2	N	1	f	2.400 000 GHz	-24.317 dBm																																											
3	N	1	f	2.390 000 GHz	-62.160 dBm																																											
4	N	1	f	2.387 045 GHz	-60.017 dBm																																											

<p>CH78 No hopping mode</p>	<p>Agilent Spectrum Analyzer - Swept SA</p> <p>Center Freq 2.489000000 GHz</p> <p>Ref Offset 1 dB Ref 20.50 dBm</p> <p>Mkr4 2.483 502 75 GHz -43.058 dBm</p> <p>Start 2.47800 GHz #Res BW 100 kHz</p> <p>Stop 2.50000 GHz #VBW 300 kHz Sweep 2.133 ms (8001 pts)</p> <table border="1"> <thead> <tr> <th>MKR</th> <th>MODE</th> <th>TRC</th> <th>SCL</th> <th>X</th> <th>Y</th> <th>FUNCTION</th> <th>FUNCTION WIDTH</th> <th>FUNCTION VALUE</th> </tr> </thead> <tbody> <tr> <td>1</td> <td>N</td> <td>1</td> <td>f</td> <td>2.479 985 50 GHz</td> <td>7.819 dBm</td> <td></td> <td></td> <td></td> </tr> <tr> <td>2</td> <td>N</td> <td>1</td> <td>f</td> <td>2.483 500 00 GHz</td> <td>-43.027 dBm</td> <td></td> <td></td> <td></td> </tr> <tr> <td>3</td> <td>N</td> <td>1</td> <td>f</td> <td>2.500 000 00 GHz</td> <td>-57.864 dBm</td> <td></td> <td></td> <td></td> </tr> <tr> <td>4</td> <td>N</td> <td>1</td> <td>f</td> <td>2.483 502 75 GHz</td> <td>-43.058 dBm</td> <td></td> <td></td> <td></td> </tr> </tbody> </table>	MKR	MODE	TRC	SCL	X	Y	FUNCTION	FUNCTION WIDTH	FUNCTION VALUE	1	N	1	f	2.479 985 50 GHz	7.819 dBm				2	N	1	f	2.483 500 00 GHz	-43.027 dBm				3	N	1	f	2.500 000 00 GHz	-57.864 dBm				4	N	1	f	2.483 502 75 GHz	-43.058 dBm			
MKR	MODE	TRC	SCL	X	Y	FUNCTION	FUNCTION WIDTH	FUNCTION VALUE																																						
1	N	1	f	2.479 985 50 GHz	7.819 dBm																																									
2	N	1	f	2.483 500 00 GHz	-43.027 dBm																																									
3	N	1	f	2.500 000 00 GHz	-57.864 dBm																																									
4	N	1	f	2.483 502 75 GHz	-43.058 dBm																																									
<p>CH78 Hopping mode</p>	<p>Agilent Spectrum Analyzer - Swept SA</p> <p>Marker 1 2.480156000000 GHz</p> <p>Ref Offset 1 dB Ref 16.50 dBm</p> <p>Mkr4 2.483 522 GHz -44.068 dBm</p> <p>Start 2.47800 GHz #Res BW 100 kHz</p> <p>Stop 2.50000 GHz #VBW 300 kHz Sweep 2.133 ms (1001 pts)</p> <table border="1"> <thead> <tr> <th>MKR</th> <th>MODE</th> <th>TRC</th> <th>SCL</th> <th>X</th> <th>Y</th> <th>FUNCTION</th> <th>FUNCTION WIDTH</th> <th>FUNCTION VALUE</th> </tr> </thead> <tbody> <tr> <td>1</td> <td>N</td> <td>1</td> <td>f</td> <td>2.480 156 GHz</td> <td>7.595 dBm</td> <td></td> <td></td> <td></td> </tr> <tr> <td>2</td> <td>N</td> <td>1</td> <td>f</td> <td>2.483 500 GHz</td> <td>-44.069 dBm</td> <td></td> <td></td> <td></td> </tr> <tr> <td>3</td> <td>N</td> <td>1</td> <td>f</td> <td>2.500 000 GHz</td> <td>-62.369 dBm</td> <td></td> <td></td> <td></td> </tr> <tr> <td>4</td> <td>N</td> <td>1</td> <td>f</td> <td>2.483 522 GHz</td> <td>-44.068 dBm</td> <td></td> <td></td> <td></td> </tr> </tbody> </table>	MKR	MODE	TRC	SCL	X	Y	FUNCTION	FUNCTION WIDTH	FUNCTION VALUE	1	N	1	f	2.480 156 GHz	7.595 dBm				2	N	1	f	2.483 500 GHz	-44.069 dBm				3	N	1	f	2.500 000 GHz	-62.369 dBm				4	N	1	f	2.483 522 GHz	-44.068 dBm			
MKR	MODE	TRC	SCL	X	Y	FUNCTION	FUNCTION WIDTH	FUNCTION VALUE																																						
1	N	1	f	2.480 156 GHz	7.595 dBm																																									
2	N	1	f	2.483 500 GHz	-44.069 dBm																																									
3	N	1	f	2.500 000 GHz	-62.369 dBm																																									
4	N	1	f	2.483 522 GHz	-44.068 dBm																																									

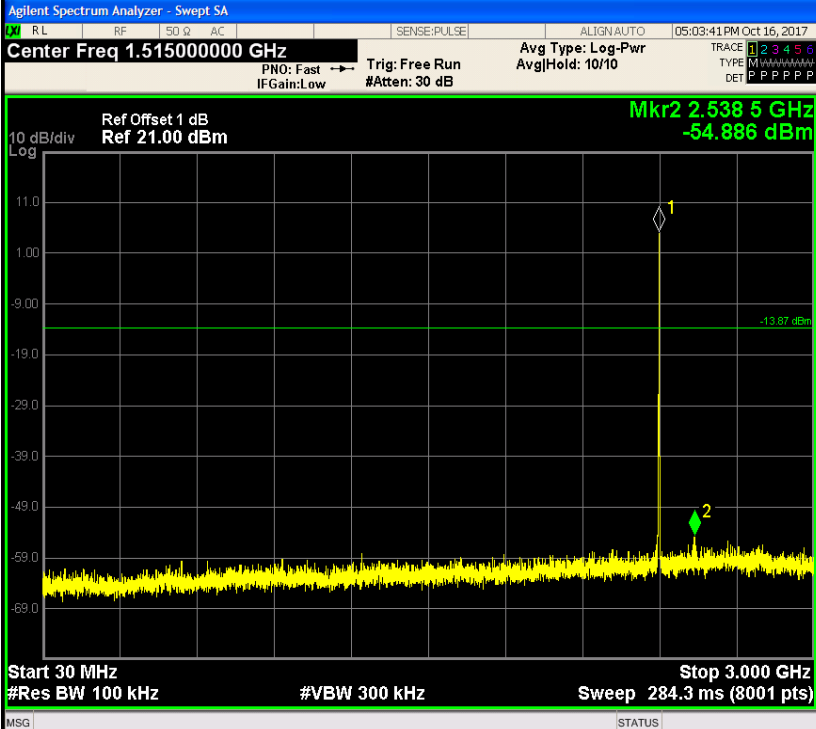
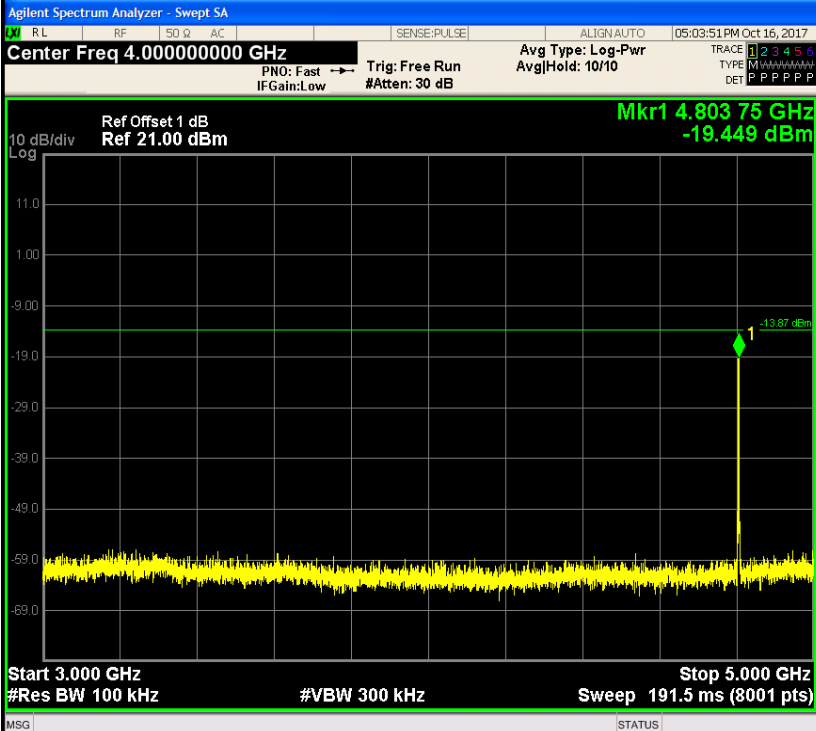
Test Item:	SE	Modulation type:	GFSK
<p>CH00 30MHz~3GHz</p>	 <p>Agilent Spectrum Analyzer - Swept SA Center Freq 1.515000000 GHz Ref Offset 1 dB Ref 21.00 dBm Mkr2 2.538 5 GHz -54.886 dBm Start 30 MHz #Res BW 100 kHz #VBW 300 kHz Stop 3.000 GHz Sweep 284.3 ms (8001 pts)</p>		
<p>CH00 3GHz~5GHz</p>	 <p>Agilent Spectrum Analyzer - Swept SA Center Freq 4.000000000 GHz Ref Offset 1 dB Ref 21.00 dBm Mkr1 4.803 75 GHz -19.449 dBm Start 3.000 GHz #Res BW 100 kHz #VBW 300 kHz Stop 5.000 GHz Sweep 191.5 ms (8001 pts)</p>		

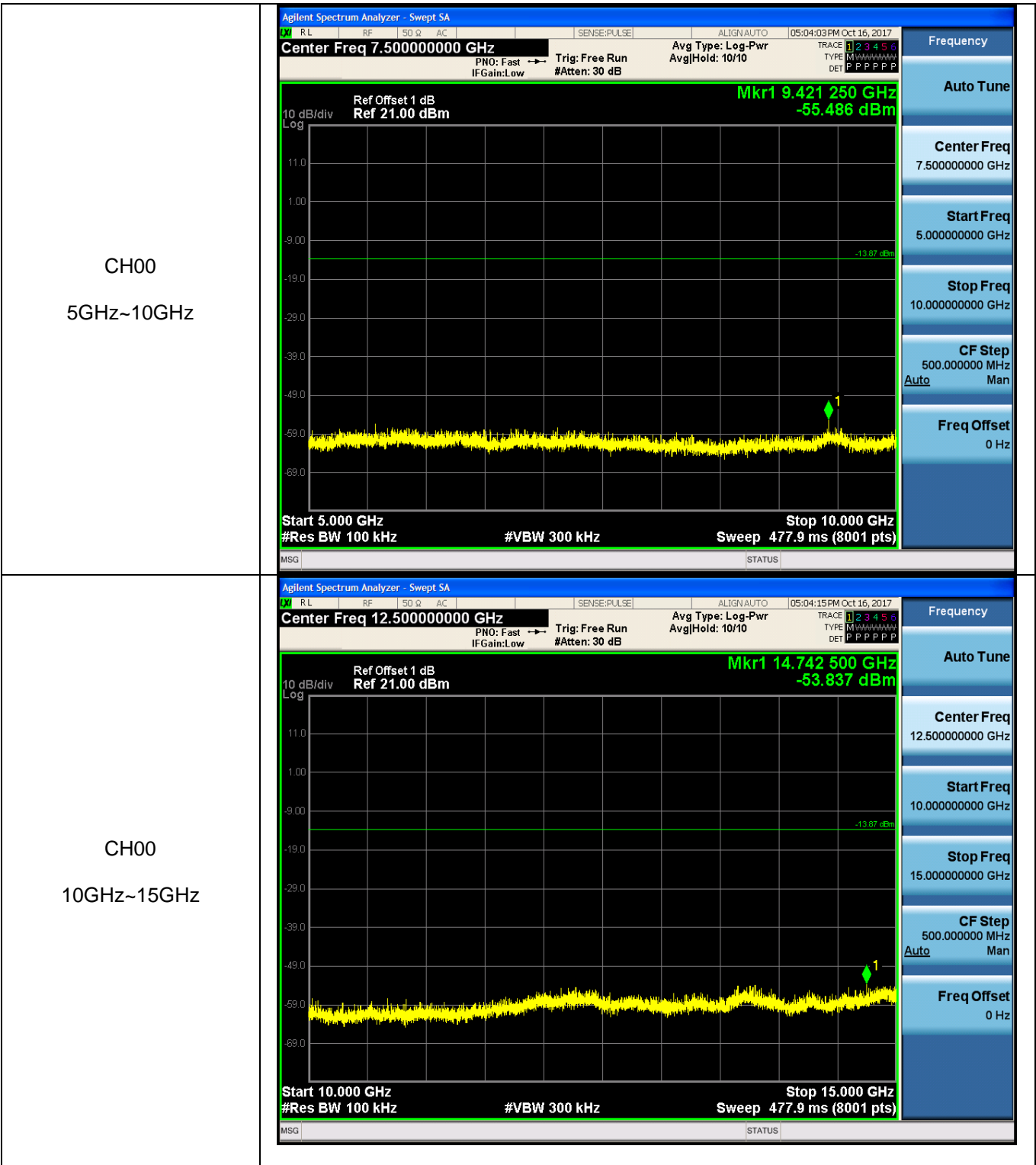

CH00
15GHz~25GHz



CH39
30MHz~3GHz

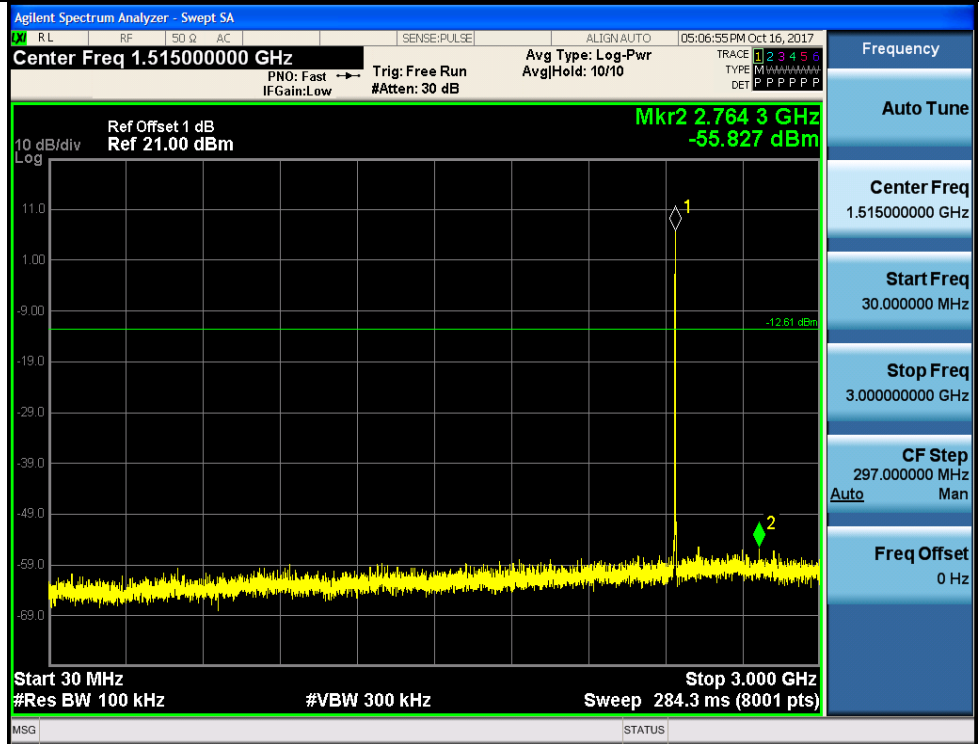

CH39
3GHz~5GHz

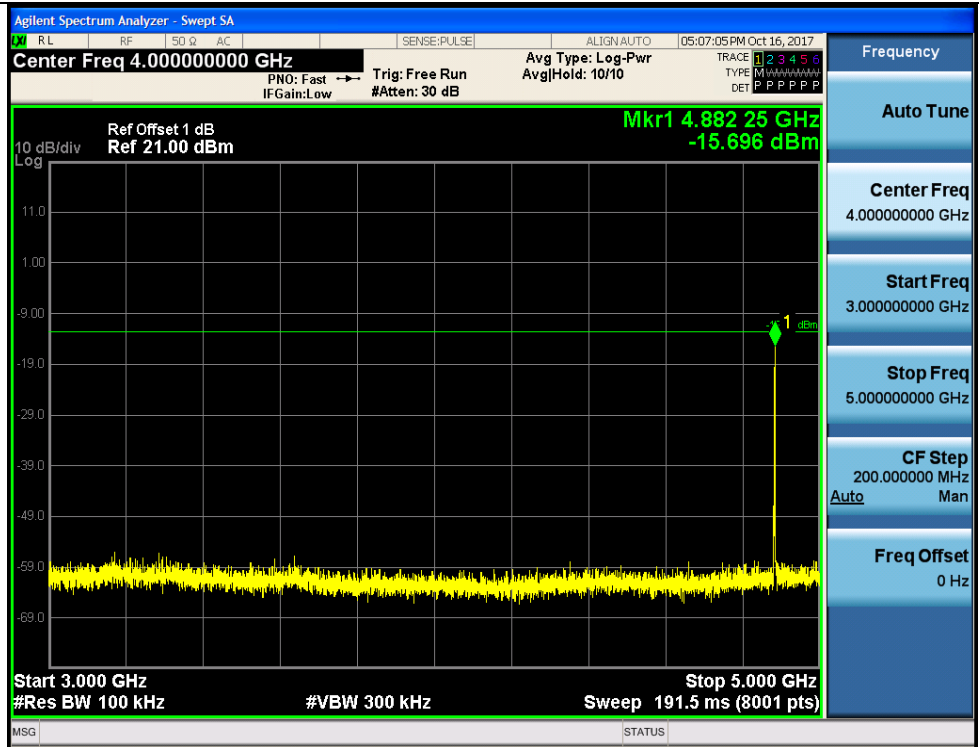

CH39
5GHz~10GHz

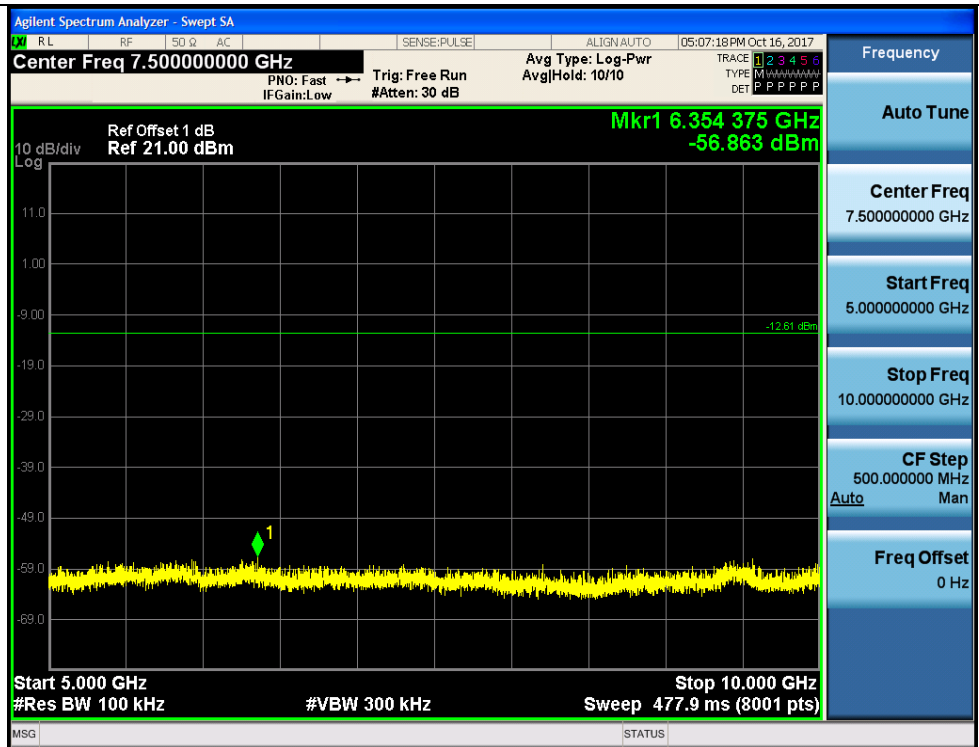

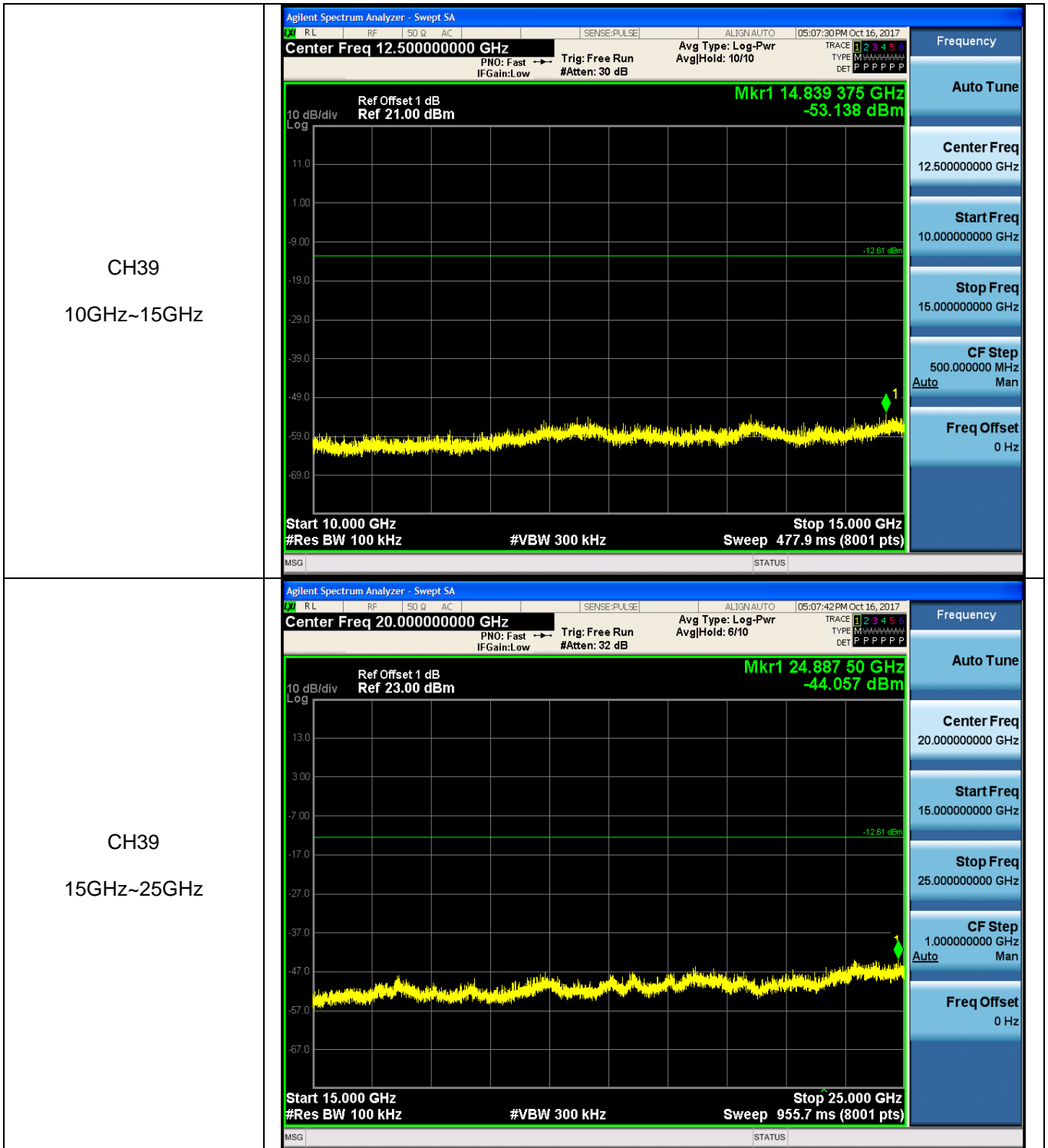

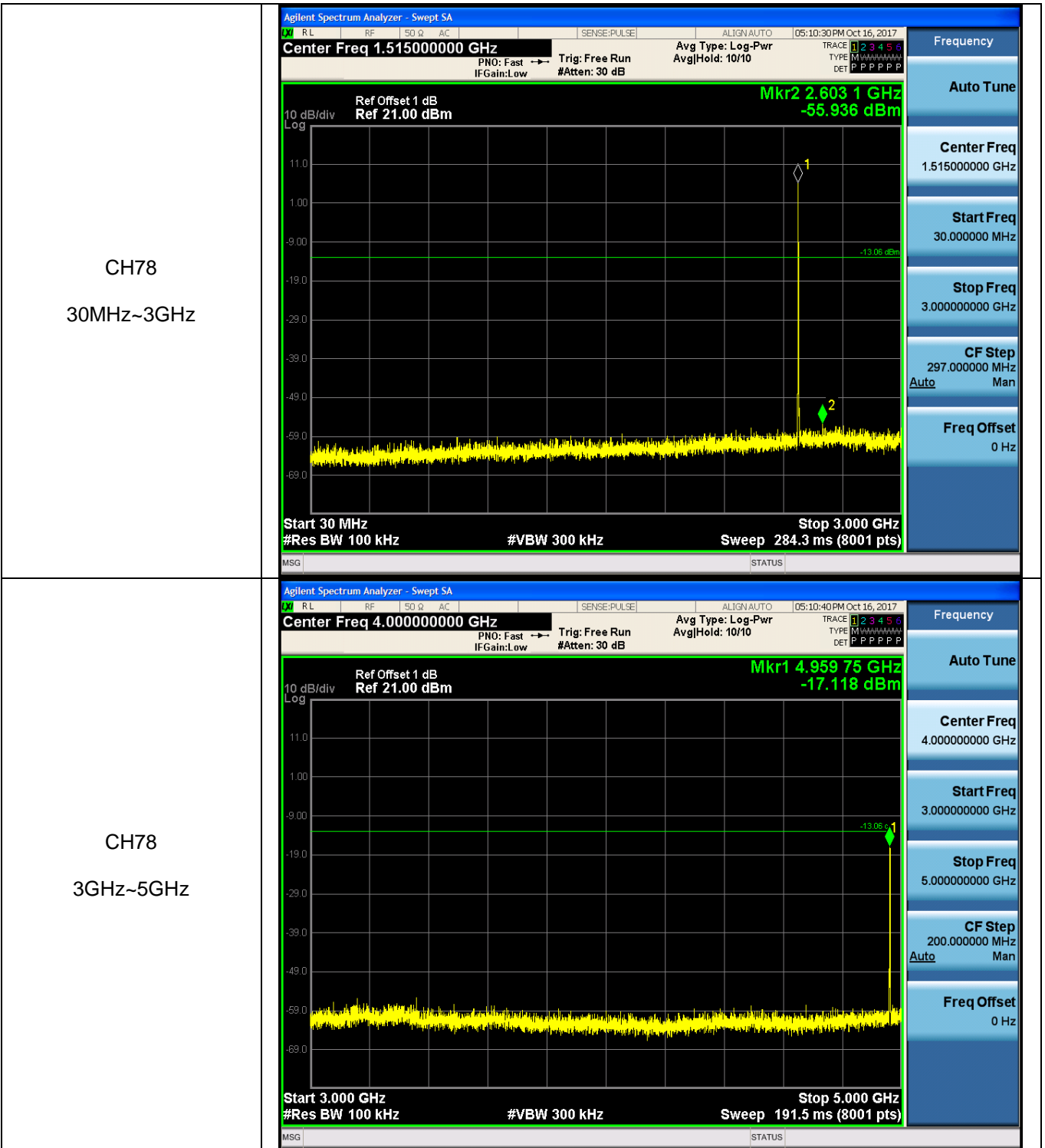

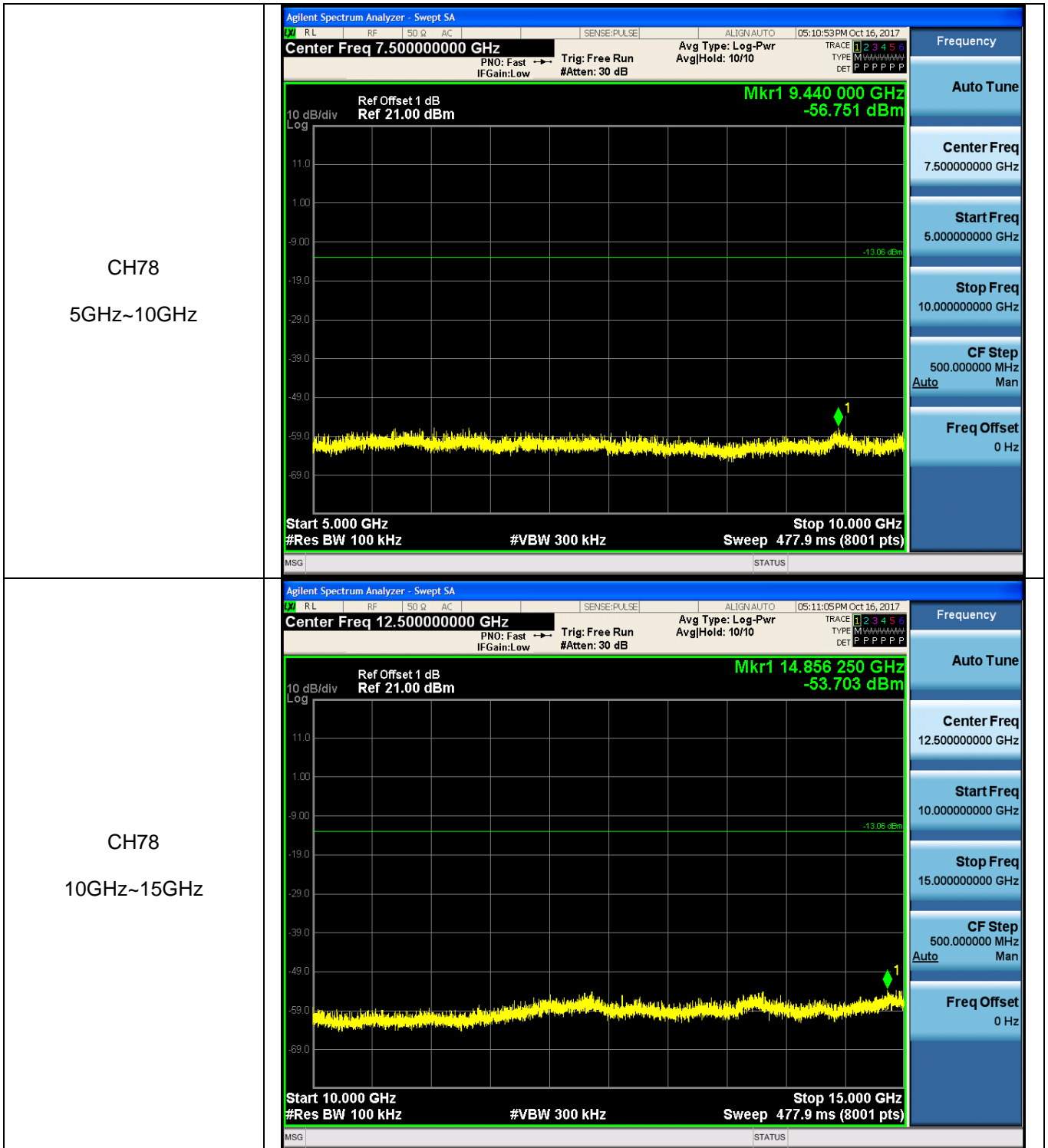

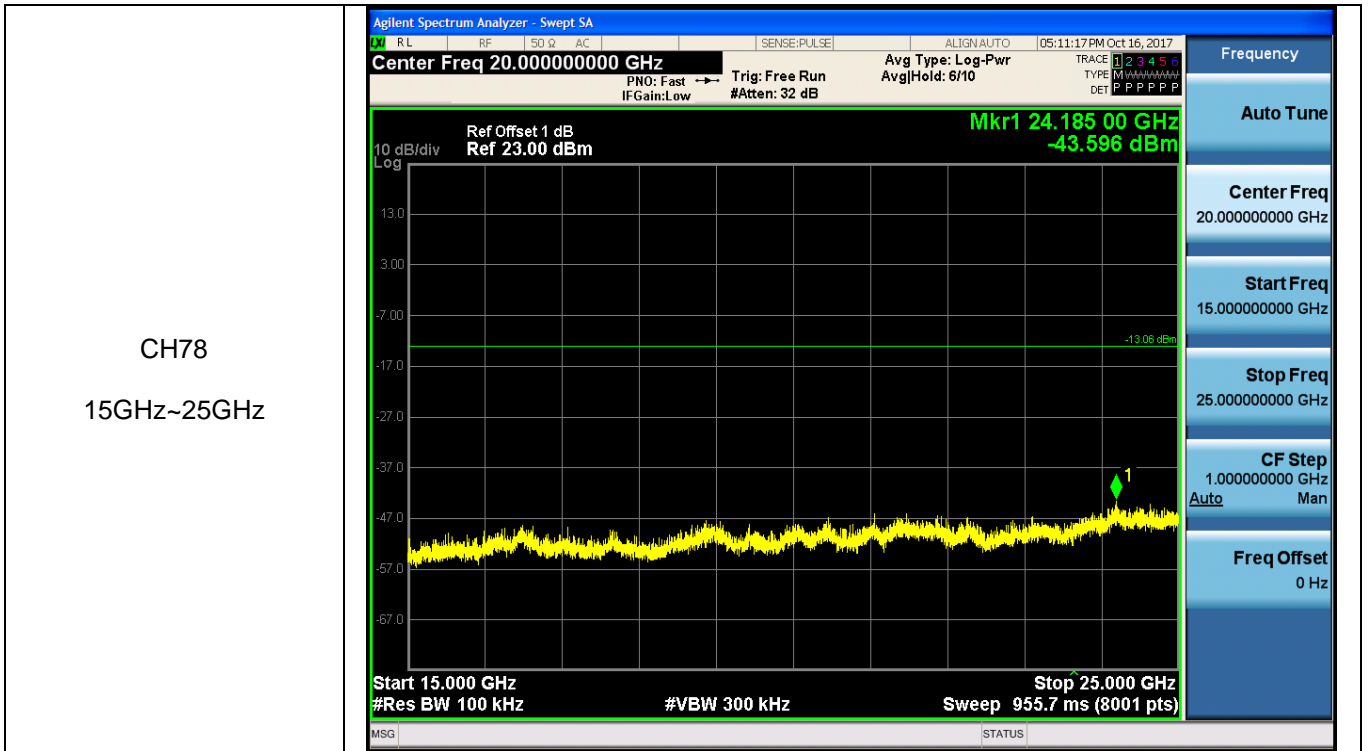

Test Item:	SE	Modulation type:	$\pi/4$ DQPSK
<p>CH00 30MHz~3GHz</p>	<p>Agilent Spectrum Analyzer - Swept SA</p> <p>Center Freq 1.515000000 GHz</p> <p>Mkr2 2.8081 GHz -56.111 dBm</p> <p>Start 30 MHz #Res BW 100 kHz #VBW 300 kHz Sweep 284.3 ms (8001 pts)</p> <p>Frequency: 1.51500000 GHz Auto Tune Center Freq: 1.51500000 GHz Start Freq: 30.000000 MHz Stop Freq: 3.00000000 GHz CF Step: 297.000000 MHz Freq Offset: 0 Hz</p>		
<p>CH00 3GHz~5GHz</p>	<p>Agilent Spectrum Analyzer - Swept SA</p> <p>Center Freq 4.000000000 GHz</p> <p>Mkr1 4.80350 GHz -20.696 dBm</p> <p>Start 3.000 GHz #Res BW 100 kHz #VBW 300 kHz Sweep 191.5 ms (8001 pts)</p> <p>Frequency: 4.00000000 GHz Auto Tune Center Freq: 4.00000000 GHz Start Freq: 3.00000000 GHz Stop Freq: 5.00000000 GHz CF Step: 200.000000 MHz Freq Offset: 0 Hz</p>		

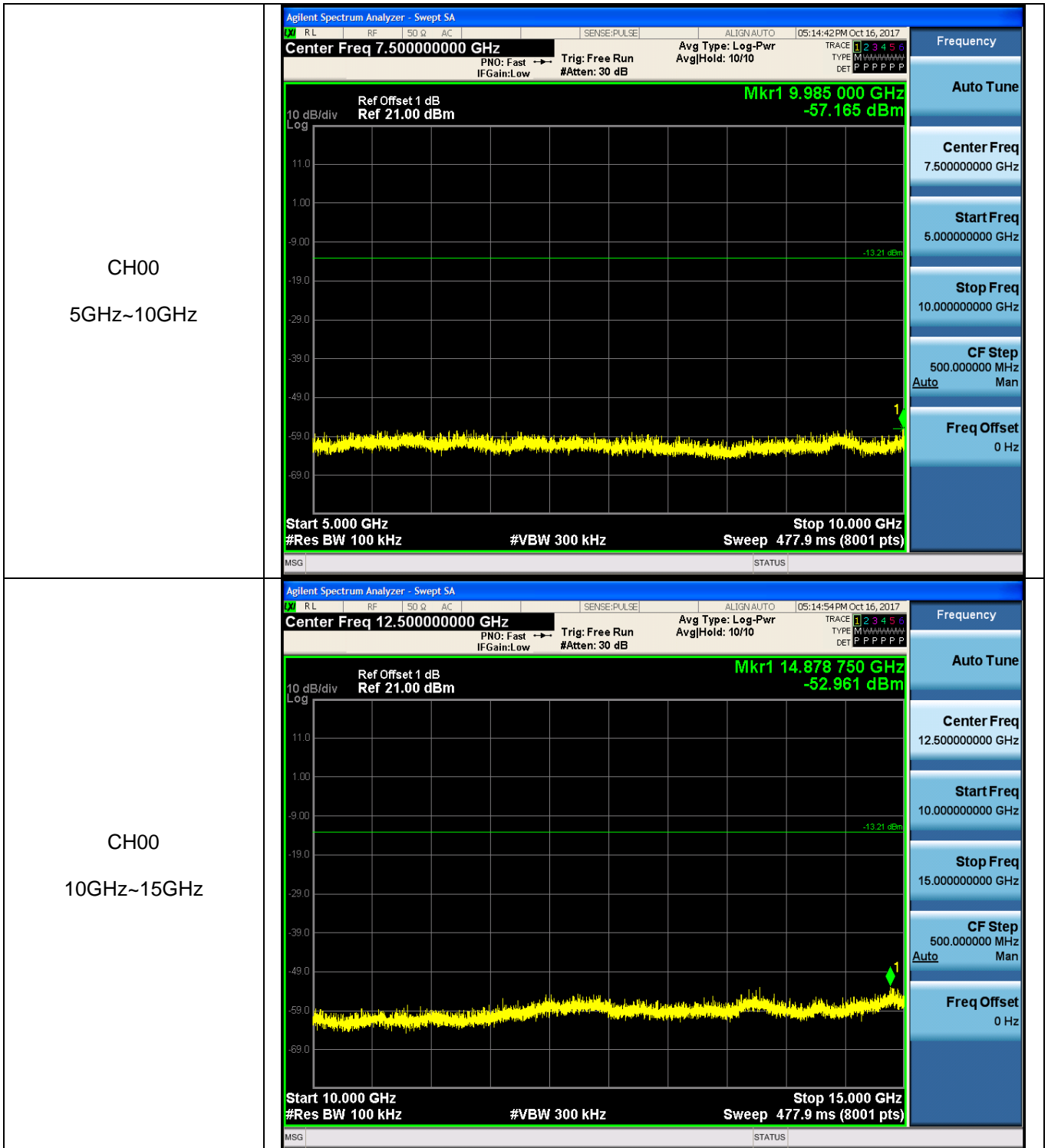

CH00
15GHz~25GHz



CH39
30MHz~3GHz

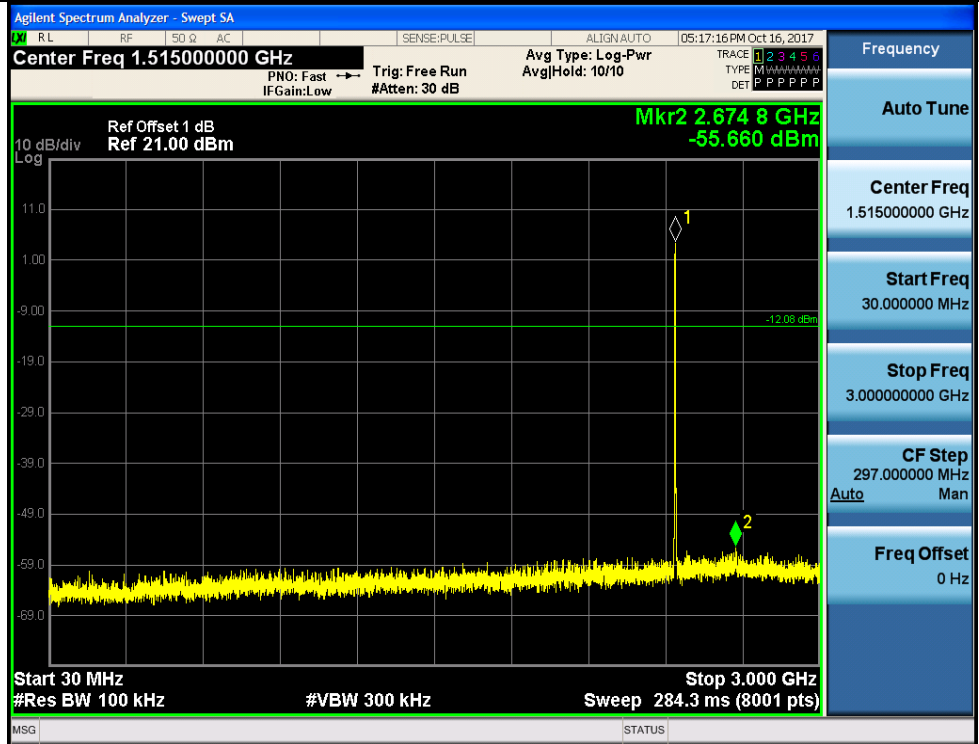

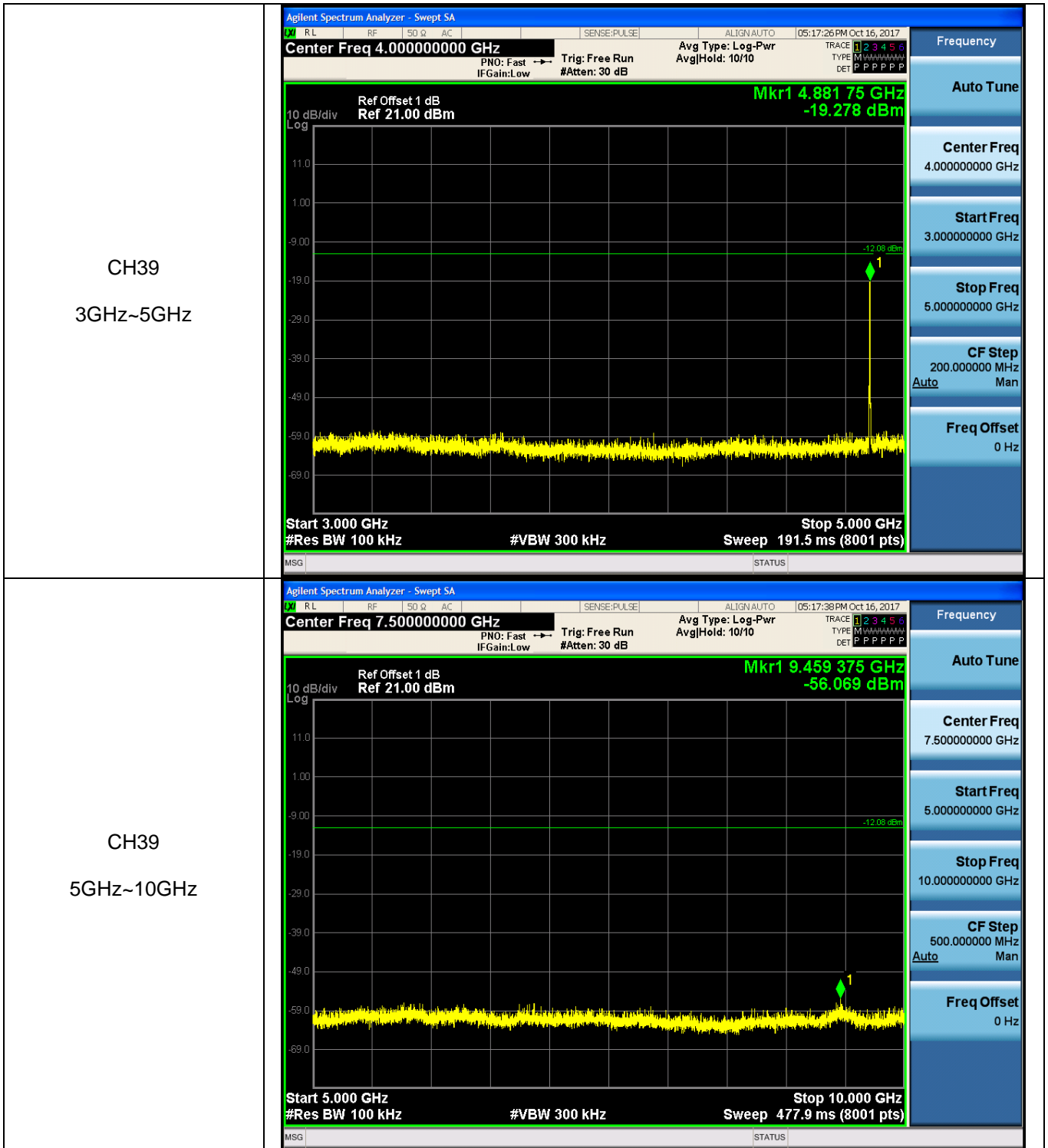

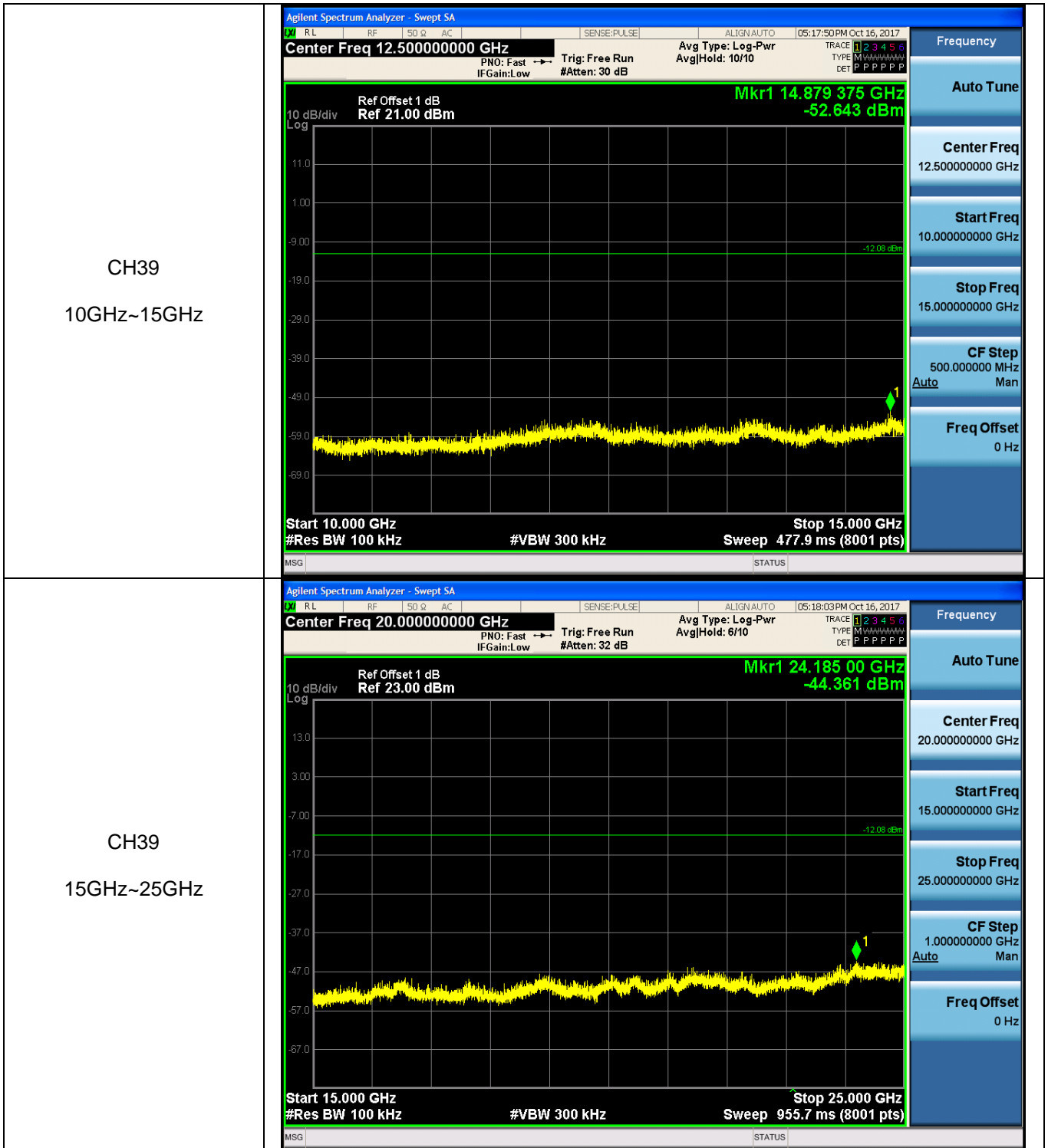

CH78
30MHz~3GHz

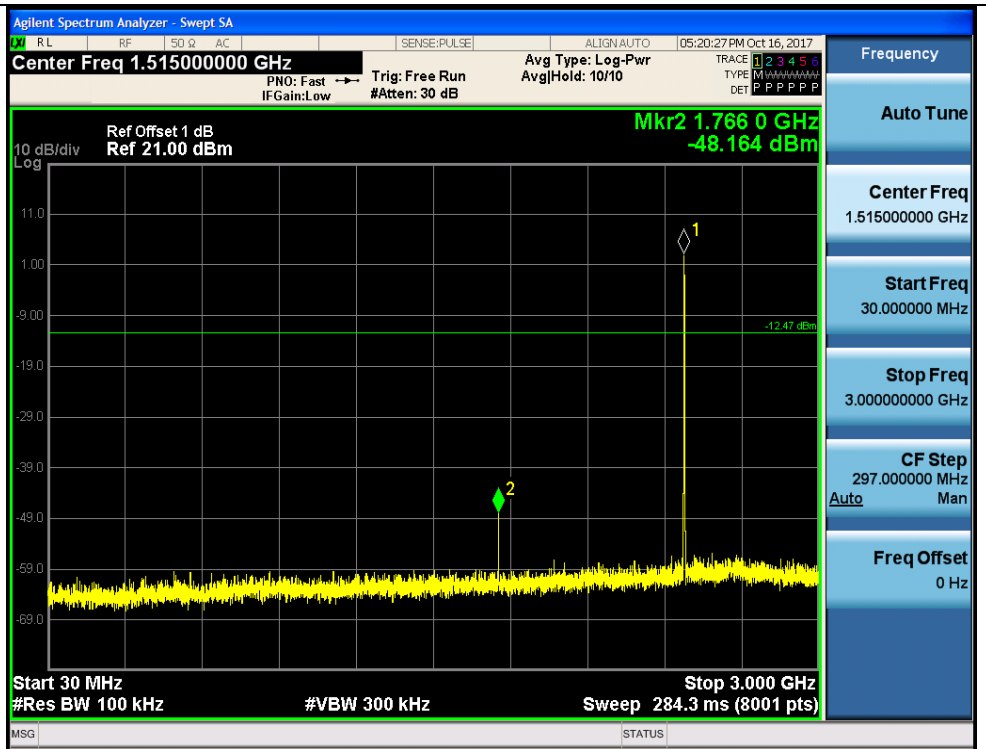

CH78
3GHz~5GHz

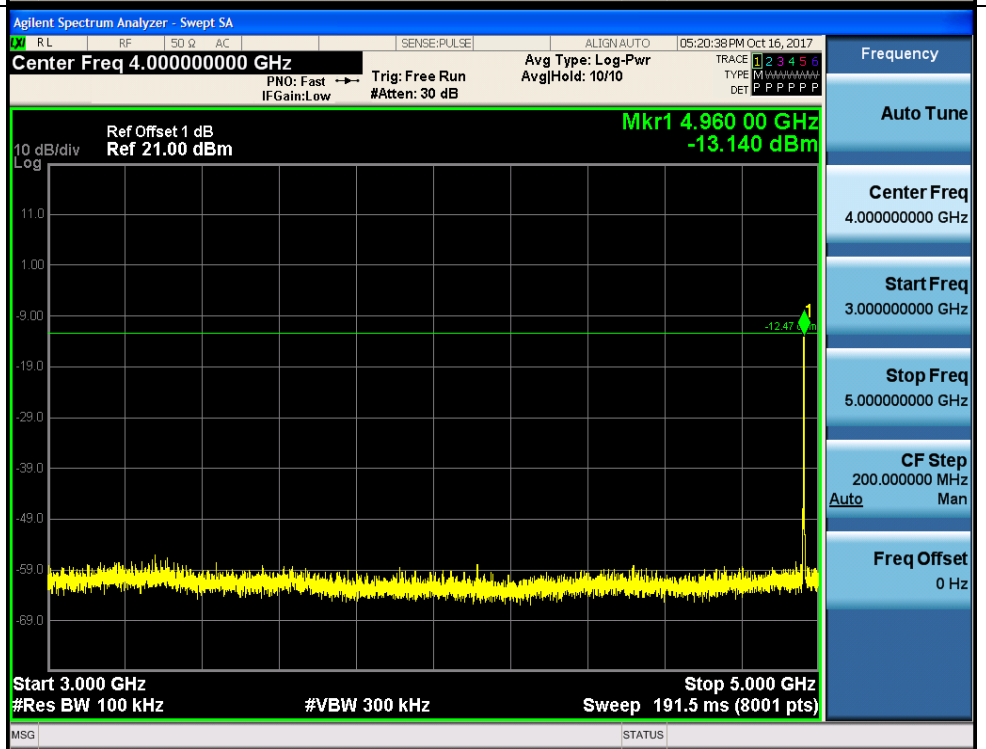

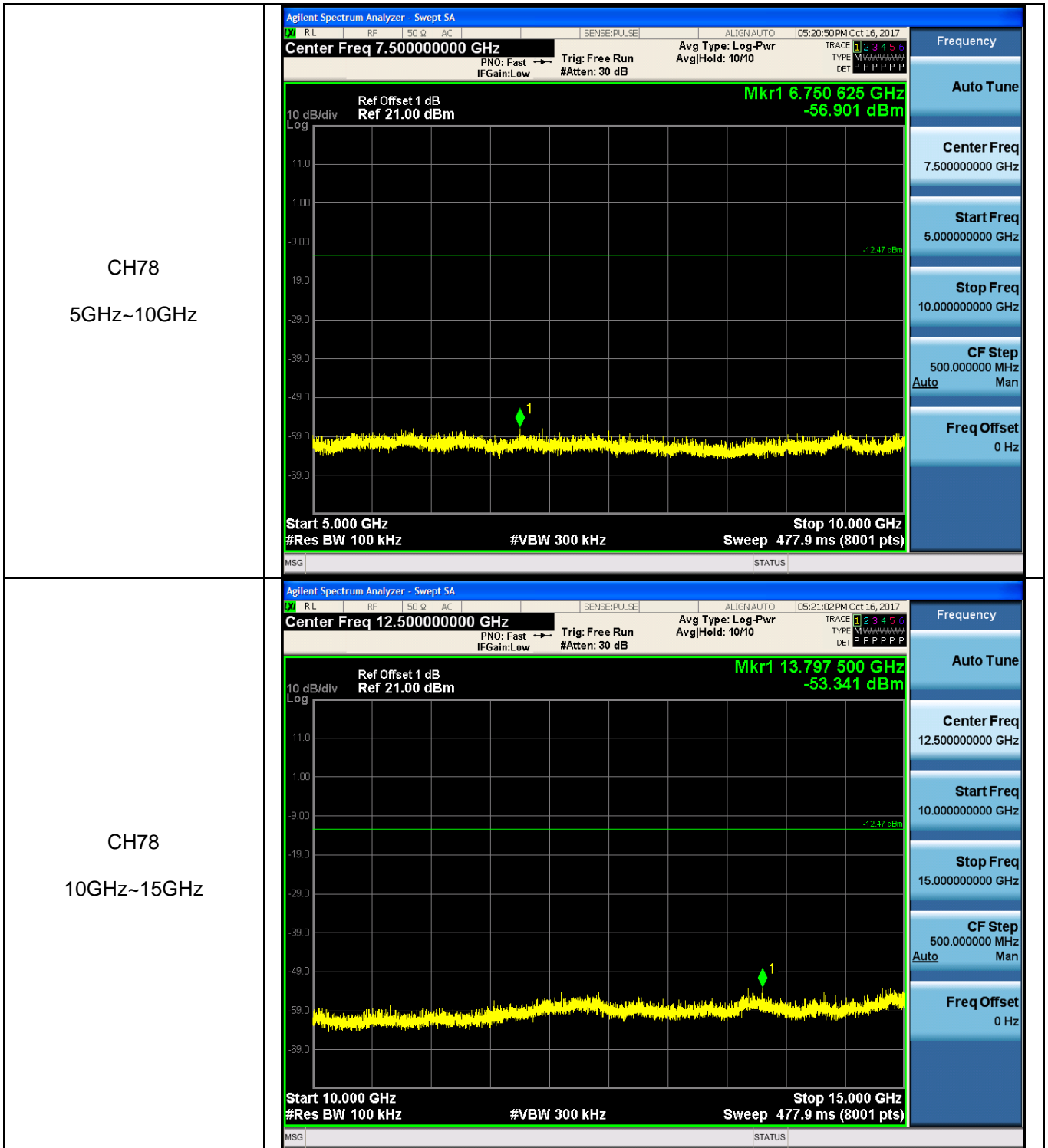

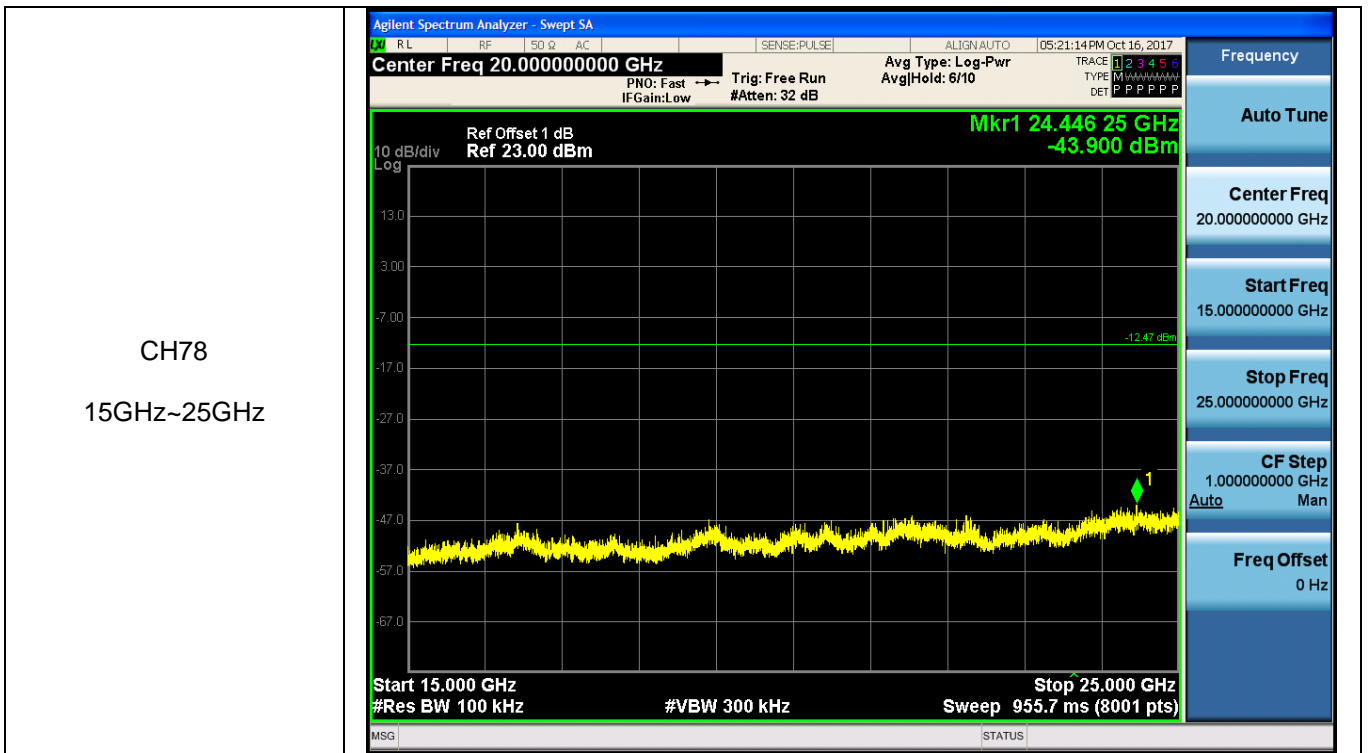

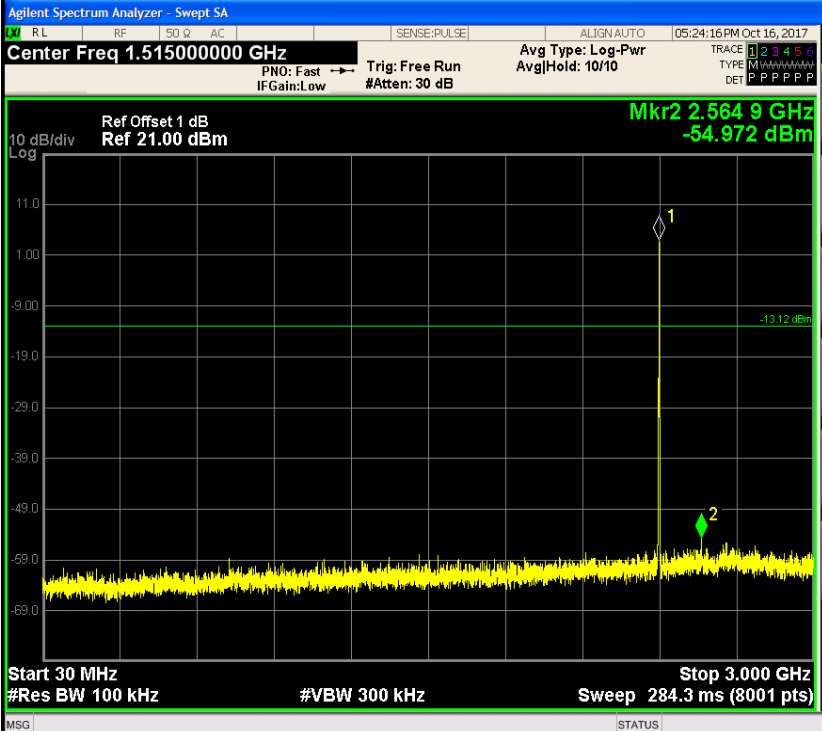
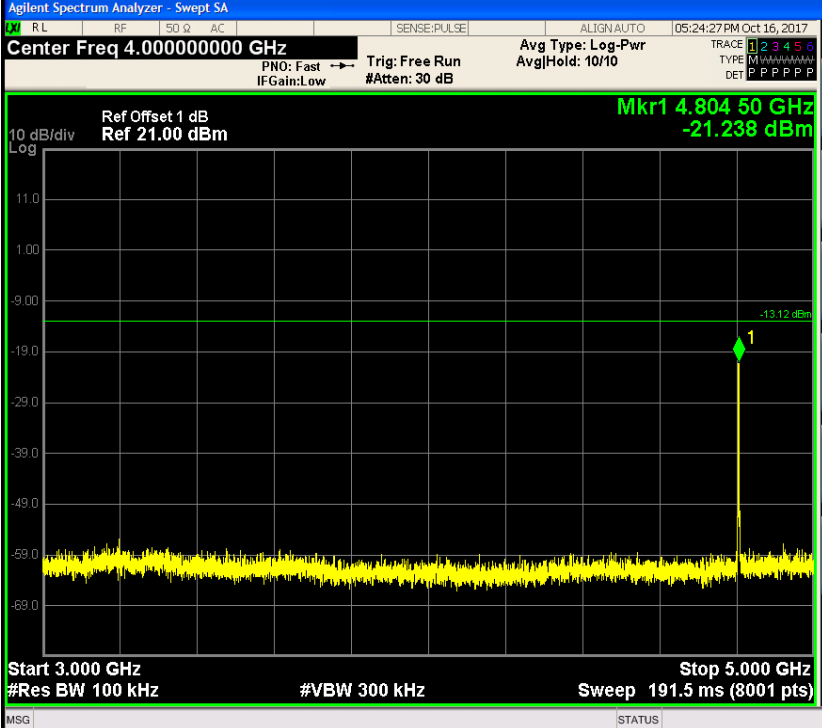
Test Item:	SE	Modulation type:	8DPSK
<p>CH00 30MHz~3GHz</p>	 <p>Agilent Spectrum Analyzer - Swept SA</p> <p>Center Freq 1.515000000 GHz</p> <p>Mkr2 2.564 9 GHz -54.972 dBm</p> <p>Start 30 MHz #Res BW 100 kHz #VBW 300 kHz Sweep 284.3 ms (8001 pts)</p>		
<p>CH00 3GHz~5GHz</p>	 <p>Agilent Spectrum Analyzer - Swept SA</p> <p>Center Freq 4.000000000 GHz</p> <p>Mkr1 4.804 50 GHz -21.238 dBm</p> <p>Start 3.000 GHz #Res BW 100 kHz #VBW 300 kHz Sweep 191.5 ms (8001 pts)</p>		

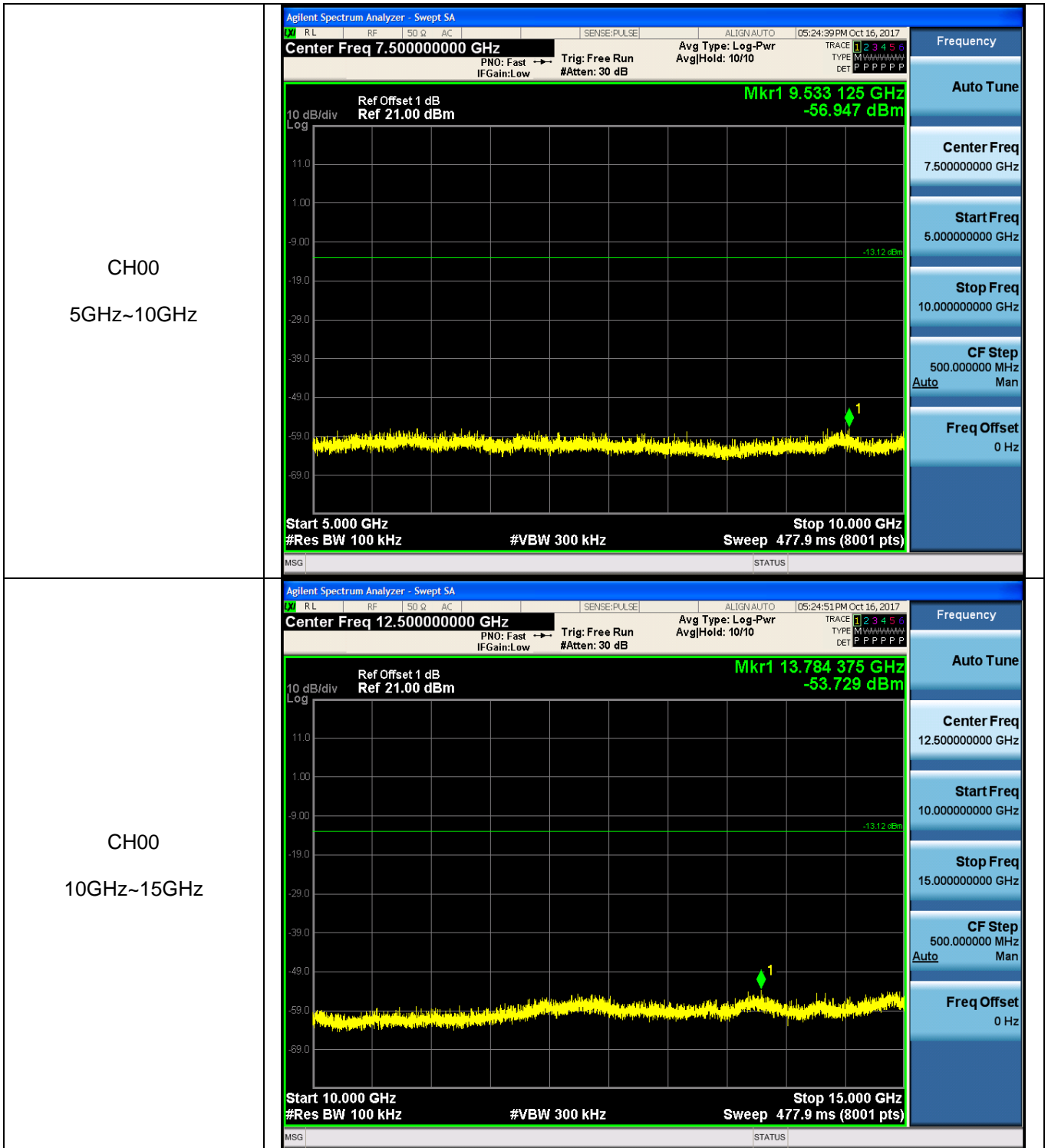

CH00
15GHz~25GHz



CH39
30MHz~3GHz

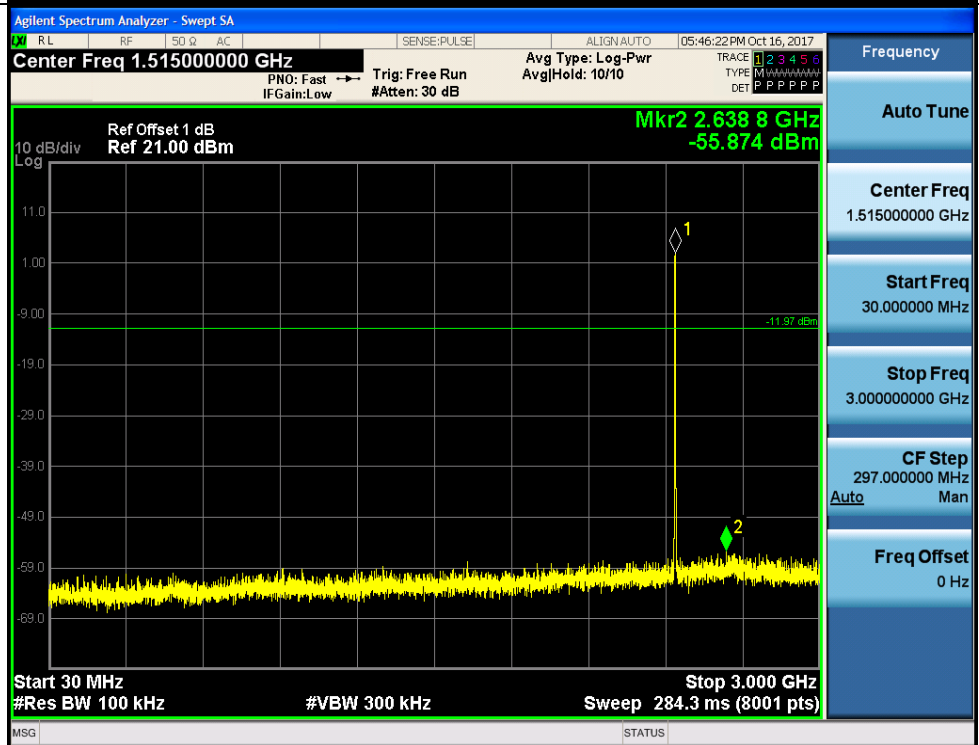

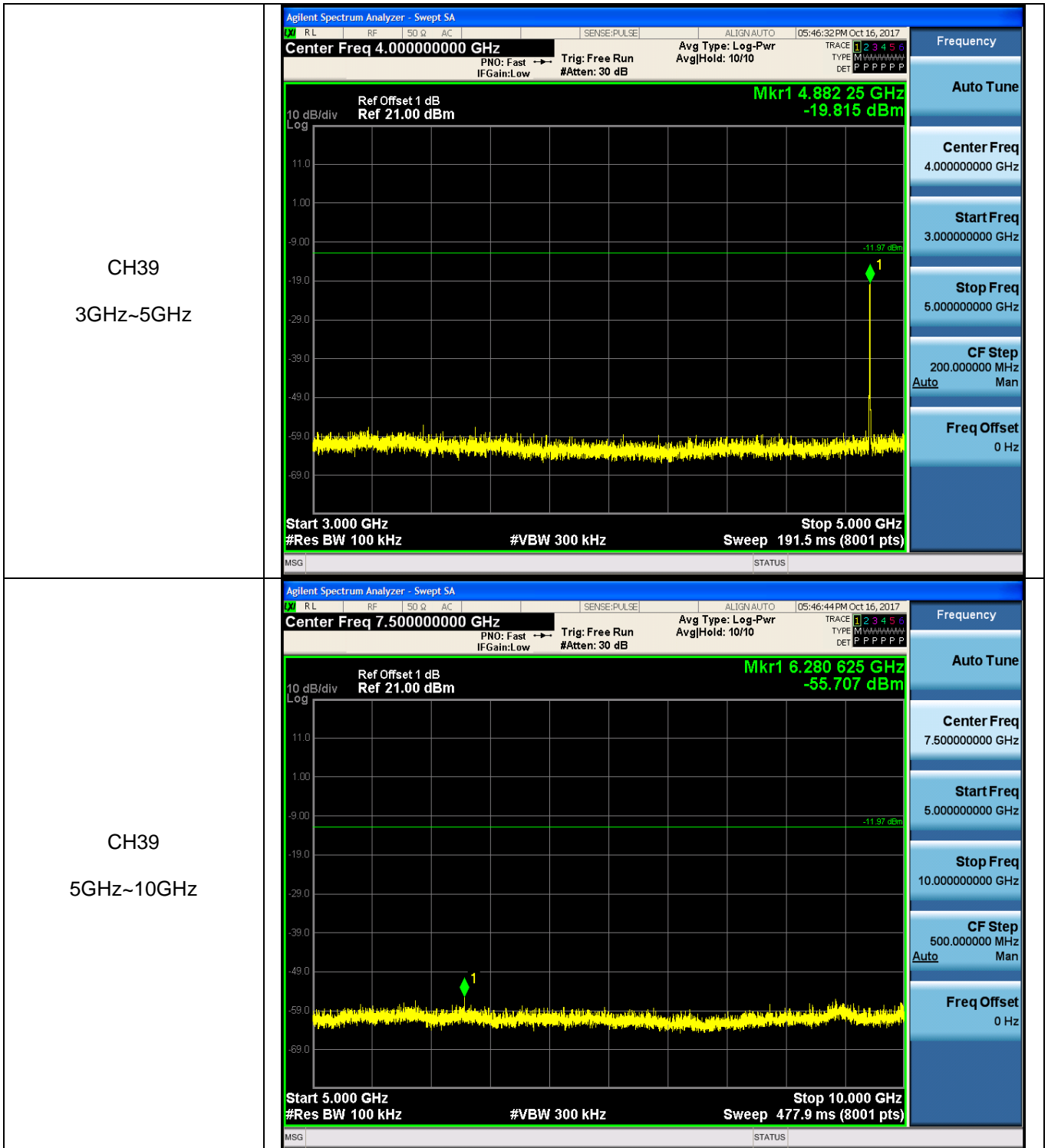

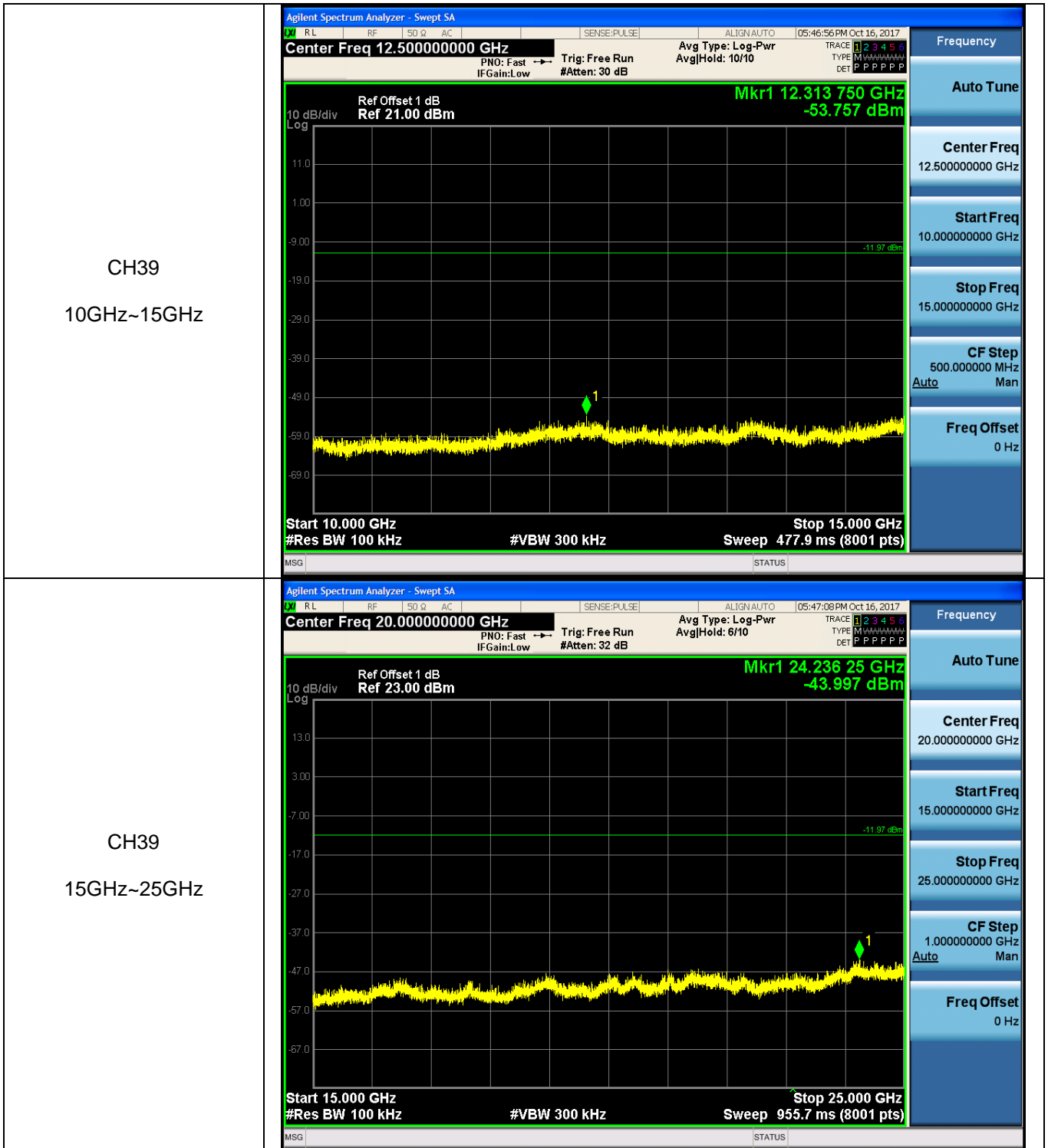

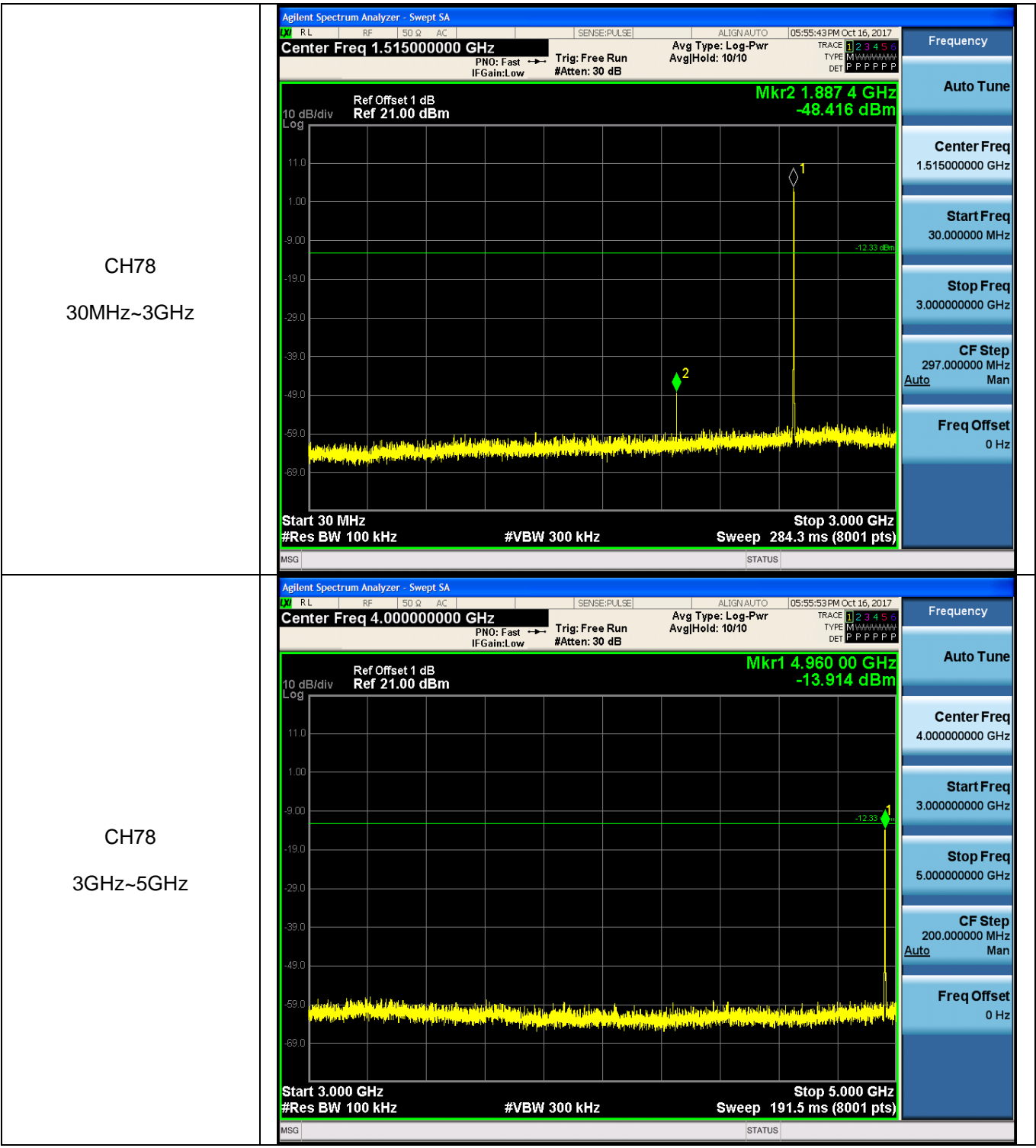

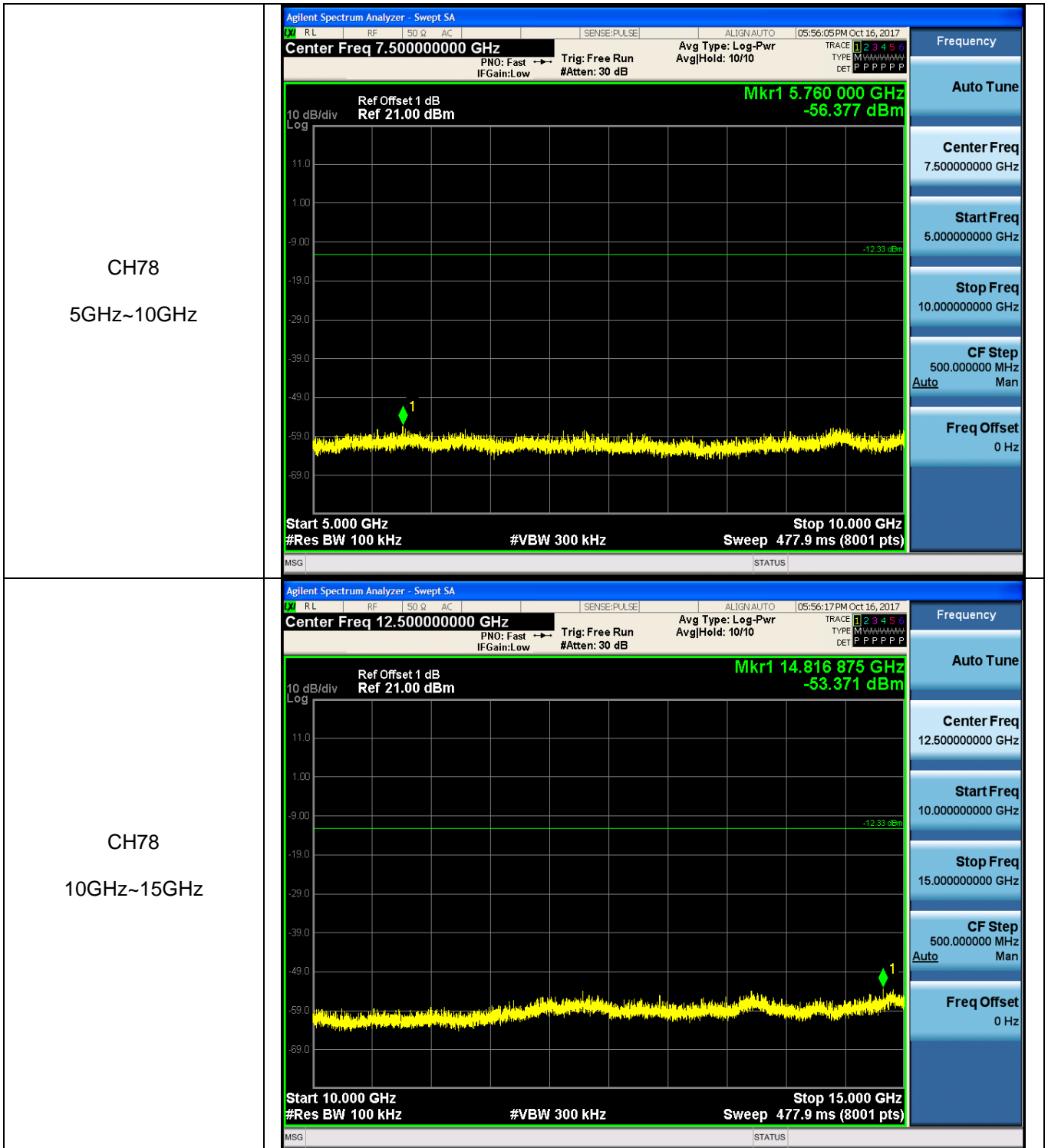

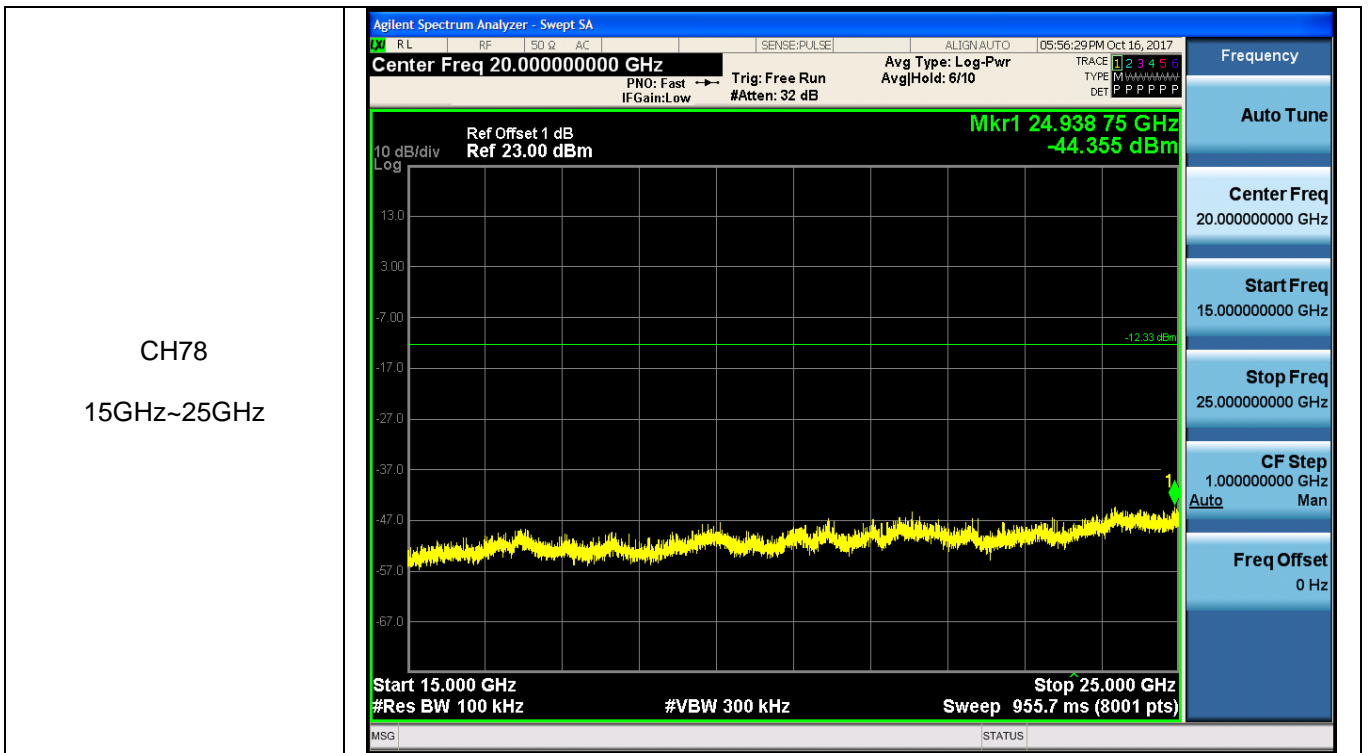

5.11. Spurious Emissions (radiated)

LIMIT

FCC CFR Title 47 Part 15 Subpart C Section 15.209

Frequency	Limit (dBuV/m @3m)	Value
30 MHz ~ 88 MHz	40.00	Quasi-peak
88 MHz ~ 216 MHz	43.50	Quasi-peak
216 MHz ~ 960 MHz	46.00	Quasi-peak
960 MHz ~ 1 GHz	54.00	Quasi-peak
Above 1 GHz	54.00	Average
	74.00	Peak

TEST CONFIGURATION

- Below 30 MHz

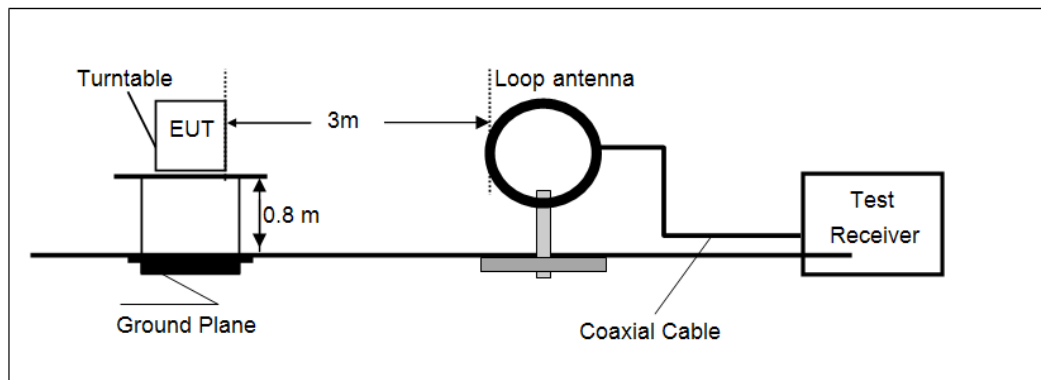

- 30 MHz ~1000 MHz

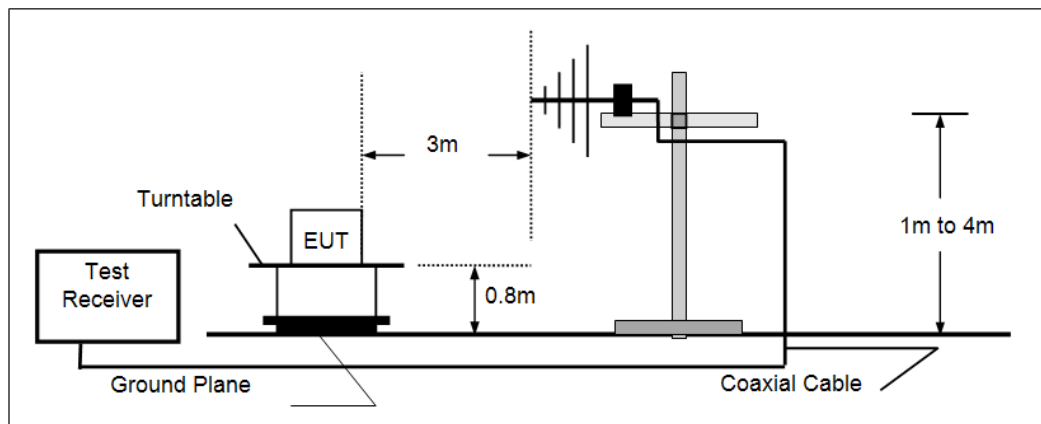

- Above 1 GHz

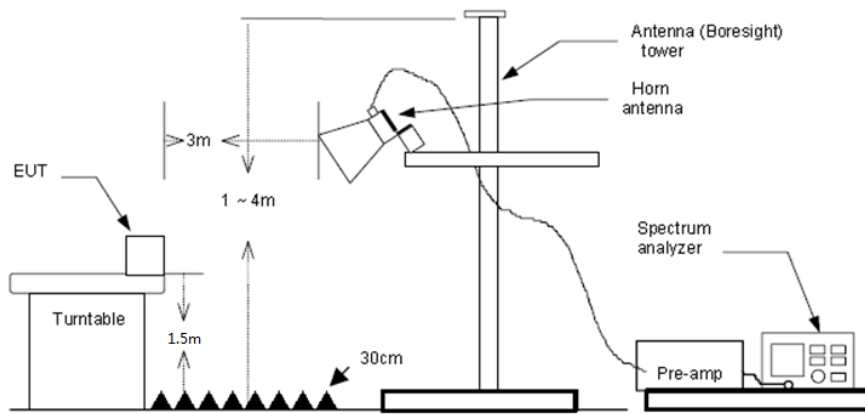

TEST PROCEDURE

1. The EUT was tested according to ANSI C63.10:2013.
2. The EUT is placed on a turn table which is 0.8 meter above ground. The turn table is rotated 360 degrees to determine the position of the maximum emission level.
3. The EUT was positioned such that the distance from antenna to the EUT was 3 meters.
4. The antenna is scanned from 1 meter to 4 meters to find out the maximum emission level. This is repeated for both horizontal and vertical polarization of the antenna.
5. Use the following spectrum analyzer settings
 - (1) Span shall wide enough to fully capture the emission being measured;
 - (2) Below 1 GHz, RBW=120 kHz, VBW=300 kHz, Sweep=auto, Detector function=peak, Trace=max hold; If the emission level of the EUT measured by the peak detector is 3 dB lower than the applicable limit, the peak emission level will be reported. Otherwise, the emission measurement will be repeated using the quasi-peak detector and reported.
 - (3) Above 1 GHz, RBW=1 MHz, VBW=3 MHz Peak detector for Peak value
RBW=1 MHz, VBW=10 Hz Peak detector for Average value.

TEST MODE:

Please refer to the clause 3.3

TEST RESULTS

Passed Not Applicable

Note:

- 1) Final Level = Receiver Read level + Antenna Factor + Cable Loss – Preamplifier Factor
- 2) The emission levels of other frequencies are very lower than the limit and not show in test report.
- 3) Below 1 GHz, Have pre-scan all modulation mode, found the GFSK modulation High channel which it was worst case, so only the worst case's data on the test report.
- 4) Above 1 GHz, Have pre-scan all modulation mode, found the GFSK modulation which it was worst case, so only the worst case's data on the test report
- 5) The peak level is lower than average limit(54 dBuV/m), this data is the too weak instrument of signal is unable to test.

➤ 9 kHz ~ 30 MHz

The low frequency, which started from 9 kHz to 30 MHz, was pre-scanned and the result which was 20 dB lower than the limit line per 15.31(o) was not reported.

➤ 30 MHz ~ 1 GHz

Polarization: Vertical

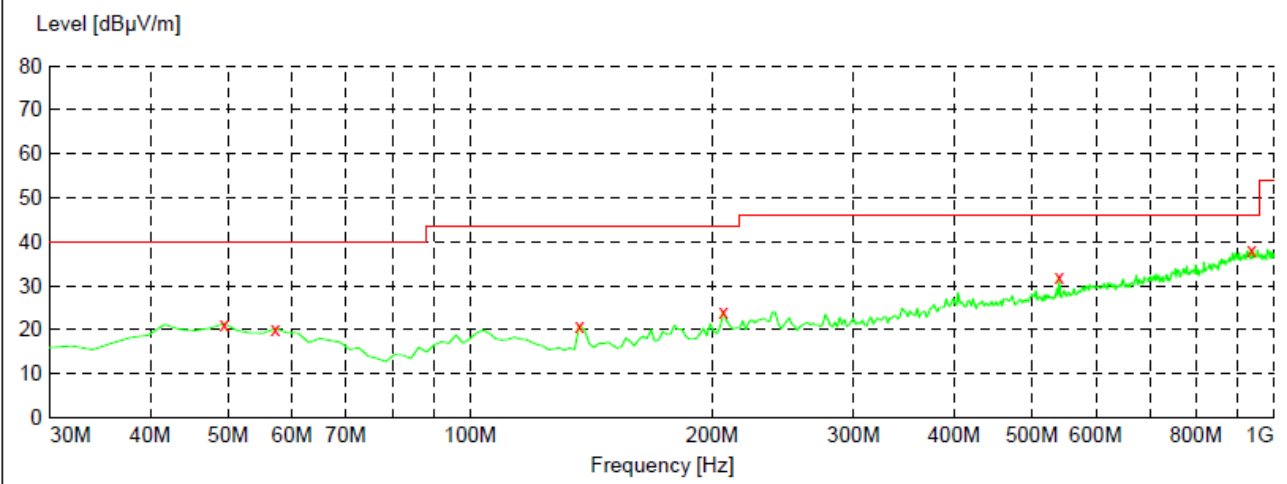

x x x MES GM1710136074_red

Frequency MHz	Level dBµV/m	Transd dB	Limit dBµV/m	Margin dB	Det.	Height cm	Azimuth deg	Polarization
49.400000	21.40	-8.7	40.0	18.6	QP	100.0	0.00	VERTICAL
57.160000	20.30	-9.4	40.0	19.7	QP	100.0	347.00	VERTICAL
136.700000	21.00	-13.7	43.5	22.5	QP	100.0	210.00	VERTICAL
206.540000	24.10	-10.5	43.5	19.4	QP	100.0	210.00	VERTICAL
540.220000	31.90	-1.0	46.0	14.1	QP	100.0	210.00	VERTICAL
937.920000	38.30	7.1	46.0	7.7	QP	100.0	347.00	VERTICAL

Polarization: Horizontal

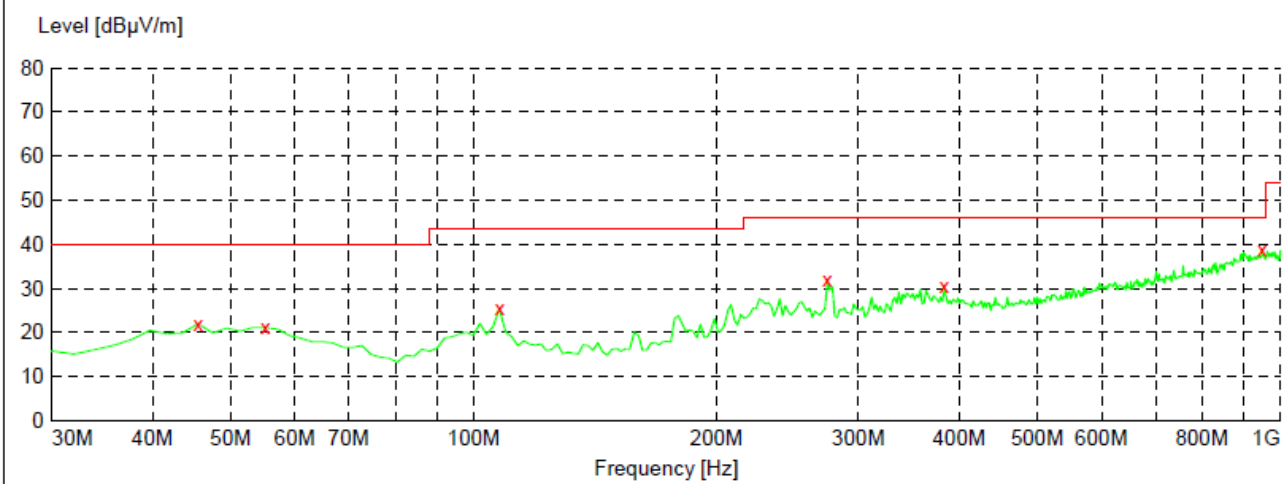

x x x MES GM1710136073_red

Frequency MHz	Level dBµV/m	Transd dB	Limit dBµV/m	Margin dB	Det.	Height cm	Azimuth deg	Polarization
45.520000	22.00	-8.8	40.0	18.0	QP	300.0	154.00	HORIZONTAL
55.220000	21.10	-9.2	40.0	18.9	QP	100.0	245.00	HORIZONTAL
107.600000	25.40	-10.6	43.5	18.1	QP	300.0	360.00	HORIZONTAL
274.440000	31.90	-7.9	46.0	14.1	QP	100.0	85.00	HORIZONTAL
383.080000	30.60	-4.9	46.0	15.4	QP	100.0	273.00	HORIZONTAL
949.560000	38.80	7.2	46.0	7.2	QP	300.0	183.00	HORIZONTAL

➤ Above 1 GHz

CH00									
Frequency (MHz)	Read Level (dBuV)	Antenna Factor (dB/m)	Cable Loss (dB)	Preamp Factor (dB)	Level (dBuV/m)	Limit Line (dBuV/m)	Over Limit (dB)	Polarization	Test value
1533.65	52.84	25.49	5.38	36.63	47.08	74.00	-26.92	Vertical	Peak
2081.55	46.45	26.63	6.34	37.32	42.10	74.00	-31.90	Vertical	Peak
3274.67	45.00	28.35	7.81	38.33	42.83	74.00	-31.17	Vertical	Peak
6428.77	33.97	33.50	11.04	35.32	43.19	74.00	-30.81	Vertical	Peak
1533.65	49.85	25.49	5.38	36.63	44.09	74.00	-29.91	Horizontal	Peak
1782.18	45.88	25.37	5.93	37.10	40.08	74.00	-33.92	Horizontal	Peak
3274.67	45.00	28.35	7.81	38.33	42.83	74.00	-31.17	Horizontal	Peak
5880.78	32.83	32.26	10.62	35.37	40.34	74.00	-33.66	Horizontal	Peak

CH39									
Frequency (MHz)	Read Level (dBuV)	Antenna Factor (dB/m)	Cable Loss (dB)	Preamp Factor (dB)	Level (dBuV/m)	Limit Line (dBuV/m)	Over Limit (dB)	Polarization	Test value
1533.65	47.72	25.49	5.38	36.63	41.96	74.00	-32.04	Vertical	Peak
3454.49	39.02	28.64	8.04	38.47	37.23	74.00	-36.77	Vertical	Peak
4883.52	46.90	31.43	9.59	36.73	51.19	54.00	-2.81	Vertical	Average
4883.52	65.77	31.43	9.59	36.73	70.06	74.00	-3.94	Vertical	Peak
7319.96	24.35	36.30	11.99	34.92	37.72	54.00	-16.28	Vertical	Average
7319.96	41.43	36.30	11.99	34.92	54.80	74.00	-19.20	Vertical	Peak
1533.65	49.54	25.49	5.38	36.63	43.78	74.00	-30.22	Horizontal	Peak
4034.78	35.51	29.77	8.81	38.03	36.06	74.00	-37.94	Horizontal	Peak
4883.52	42.37	31.43	9.59	36.73	46.66	54.00	-7.34	Horizontal	Average
4883.52	50.33	31.43	9.59	36.73	54.62	74.00	-19.38	Horizontal	Peak
7209.02	32.18	36.21	11.87	35.07	45.19	74.00	-28.81	Horizontal	Peak

CH78									
Frequency (MHz)	Read Level (dBuV)	Antenna Factor (dB/m)	Cable Loss (dB)	Preamp Factor (dB)	Level (dBuV/m)	Limit Line (dBuV/m)	Over Limit (dB)	Polarization	Test value
1533.65	50.13	25.49	5.38	36.63	44.37	74.00	-29.63	Vertical	Peak
3681.47	36.71	29.30	8.36	38.25	36.12	74.00	-37.88	Vertical	Peak
4958.68	65.16	31.46	9.64	36.52	69.74	74.00	-4.26	Vertical	Peak
4958.68	41.26	31.46	9.64	36.52	45.84	54.00	-8.16	Vertical	Average
7451.57	46.29	36.20	12.24	34.86	59.87	74.00	-14.13	Vertical	Peak
7451.57	25.56	36.20	12.24	34.86	39.14	54.00	-14.86	Vertical	Average
1533.65	45.77	25.49	5.38	36.63	40.01	74.00	-33.99	Horizontal	Peak
3057.17	36.92	28.72	7.55	38.22	34.97	74.00	-39.03	Horizontal	Peak
4958.68	65.65	31.46	9.64	36.52	70.23	74.00	-3.77	Horizontal	Peak
4958.68	45.34	31.46	9.64	36.52	49.92	54.00	-4.08	Horizontal	Average
7451.57	38.22	36.20	12.24	34.86	51.80	74.00	-22.20	Horizontal	Peak
7451.57	22.30	36.20	12.24	34.86	35.88	54.00	-18.12	Horizontal	Average

Remark:

1. Final Level = Receiver Read level + Antenna Factor + Cable Loss – Preamplifier Factor
2. The peak level is lower than average limit(54 dBuV/m), this data is the too weak instrument of signal is unable to test.
3. The emission levels of other frequencies(test frequency band is 1GHz to 25GHz) are very lower than the limit and not show in test report.

6. TEST SETUP PHOTOS

Conducted Emissions (AC Mains)



Radiated Emissions



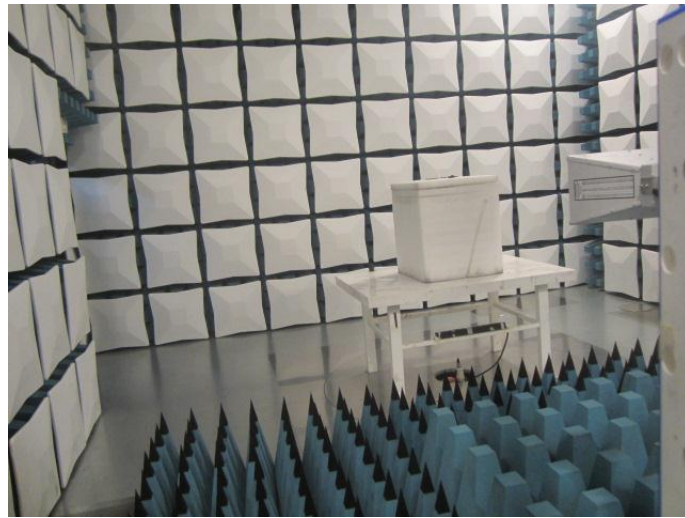

7. EXTERANAL AND INTERNAL PHOTOS

EXTERANAL PHOTOS



INTERNAL PHOTOS

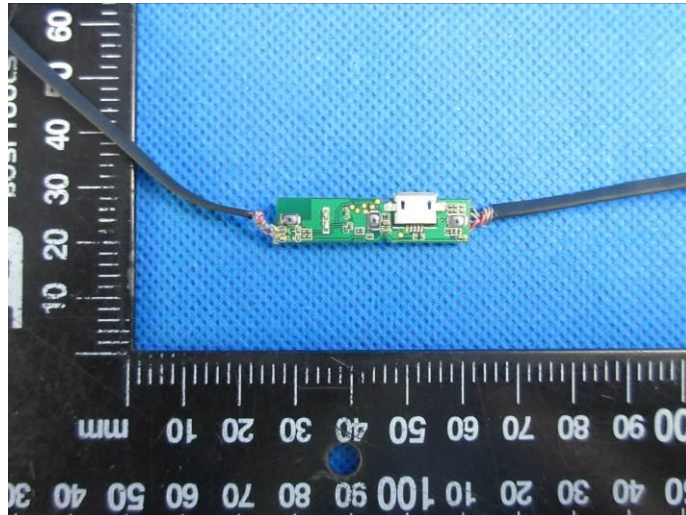
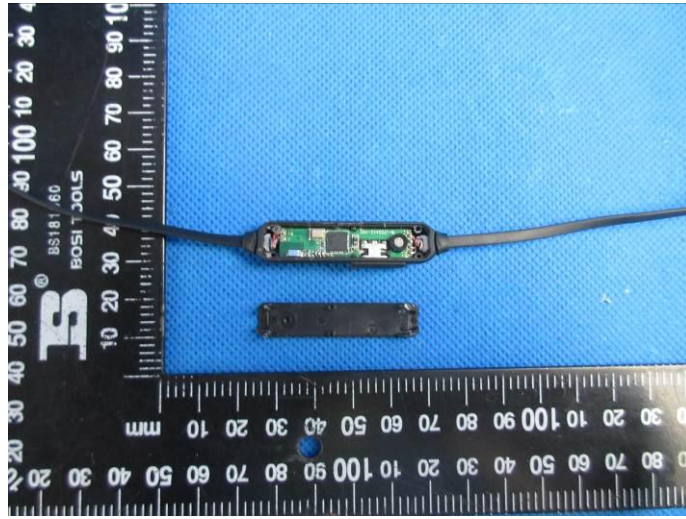



.....End of Report.....