

Certification Test Report

CFR 47 FCC Part 2 and Part 27, Subparts C and M

Model: 2.5/2.6 GHz MX8 Base Station Transceiver
2.5-2.6-BTS3A-R1 (AC Unit)
2.5-2.6-BTS3T-R1 (24 VDC Unit)
2.5-2.6-BTS3F-R1 (-48 VDC Unit)

FCC ID.: PL6-2496-BTS3-R2

Project Code: W7442

Revision: 1

Prepared for:

Author: Tom Tidwell, Manager of Wireless Services

Issued: 12 February, 2008

This report and the information contained herein represent the results of testing test articles identified and selected by the client performed to specifications and/or procedures selected by the client. National Technical Systems (NTS) makes no representations, expressed or implied, that such testing is adequate (or inadequate) to demonstrate efficiency, performance, reliability, or any other characteristic of the articles being tested, or similar products. This report should not be relied upon as an endorsement or certification by NTS of the equipment tested, nor does it represent any statement whatsoever as to its merchantability or fitness of the test article, or similar products, for a particular purpose. This report shall not be reproduced except in full.

NTS Plano, 1701 E. Plano Pkwy., Plano, TX 75074 Tel: (972) 509-2566, Fax: (972) 509-0073

Report Summary

NTS Plano

Accreditation Numbers: FCC: 101741
IC: 46405-4319 File # IC-4319A-1

Applicant: Navini Networks

Customer Representative: Larry Zhou

EUT Description:

EUT Description	Manufacturer	Model	Revision	Serial Number
The equipment tested is a base station transceiver used for wireless internet connectivity at the customer premises.	Navini Networks	2.5-2.6-BTS3A-R1 (AC Unit) 2.5-2.6-BTS3T-R1 (24 VDC Unit) 2.5-2.6-BTS3F-R1 (-48 VDC Unit)	P/N 92-92600-00	064500002

This report and the information contained herein represent the results of testing test articles identified and selected by the client performed to specifications and/or procedures selected by the client. National Technical Systems (NTS) makes no representations, expressed or implied, that such testing is adequate (or inadequate) to demonstrate efficiency, performance, reliability, or any other characteristic of the articles being tested, or similar products. This report should not be relied upon as an endorsement or certification by NTS of the equipment tested, nor does it represent any statement whatsoever as to its merchantability or fitness of the test article, or similar products, for a particular purpose. This report shall not be reproduced except in full.

NTS Plano, 1701 E. Plano Pkwy., Plano, TX 75074 Tel: (972) 509-2566, Fax: (972) 509-0073

Test Summary

Appendix	Test/Requirement Description	Deviations from:			Pass / Fail	Applicable Rule Parts
		Base Standard	Test Basis	NTS Procedure		
A	RF Power Output	No	No	No	PASS	CFR 47, Part 2, Para. 2.1046 CFR 47, Part 27, Para. 27.50(h)
B	Modulation Characteristics	No	No	No	PASS	CFR 47, Part 2, Para. 2.1047
C	Occupied Bandwidth	No	No	No	PASS	CFR 47, Part 2, Para. 2.1049 CFR 47, Part 27, Para. 27.53(l)
D	Spurious Emissions at Antenna Terminals	No	No	No	PASS	CFR 47, Part 2, Para. 2.1051 CFR 47, Part 27, Para. 27.53(l)
E	Field Strength of Spurious Radiation	No	No	No	PASS	CFR 47, Part 2, Para. 2.1053 CFR 47, Part 27, Para. 27.53(l)
F	Frequency Stability	No	No	No	PASS	CFR 47, Part 2, Para. 2.1055 CFR 47, Part 27, Para. 27.54

Test Result: The product presented for testing complied with test requirements as shown above.

This is to certify that the preceding report is true and correct to the best of my knowledge.

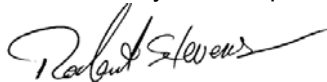

 Robert Stevens,
 Quality Assurance Manager



 Tom Tidwell,
 Wireless Test Engineer

This report and the information contained herein represent the results of testing test articles identified and selected by the client performed to specifications and/or procedures selected by the client. National Technical Systems (NTS) makes no representations, expressed or implied, that such testing is adequate (or inadequate) to demonstrate efficiency, performance, reliability, or any other characteristic of the articles being tested, or similar products. This report should not be relied upon as an endorsement or certification by NTS of the equipment tested, nor does it represent any statement whatsoever as to its merchantability or fitness of the test article, or similar products, for a particular purpose. This report shall not be reproduced except in full.

Table of Contents

REPORT SUMMARY2

TEST SUMMARY.....3

REGISTER OF REVISIONS5

INTRODUCTION.....6

1.1 PURPOSE6

2.0 EUT DESCRIPTION6

2.1 CONFIGURATION6

2.1.1 EUT POWER6

2.2 EUT CABLES7

2.3 MODE OF OPERATION DURING TESTS7

3.0 SUPPORT EQUIPMENT8

3.1 CONFIGURATION8

3.2 TEST BED/PERIPHERAL CABLES8

APPENDICES9

APPENDIX A: 2.1046 RF POWER OUTPUT10

APPENDIX B: 2.1047 MODULATION CHARACTERISTICS13

APPENDIX C: 2.10.49 OCCUPIED BANDWIDTH15

APPENDIX D: 2.1051 SPURIOUS EMISSIONS AT ANTENNA TERMINALS24

APPENDIX E: 2.1053 FIELD STRENGTH OF SPURIOUS RADIATION39

APPENDIX F: 2.1055 FREQUENCY STABILITY44

APPENDIX G: TEST EQUIPMENT LIST60

END OF DOCUMENT61

This report and the information contained herein represent the results of testing test articles identified and selected by the client performed to specifications and/or procedures selected by the client. National Technical Systems (NTS) makes no representations, expressed or implied, that such testing is adequate (or inadequate) to demonstrate efficiency, performance, reliability, or any other characteristic of the articles being tested, or similar products. This report should not be relied upon as an endorsement or certification by NTS of the equipment tested, nor does it represent any statement whatsoever as to its merchantability or fitness of the test article, or similar products, for a particular purpose. This report shall not be reproduced except in full.

Register of revisions

Revision	Reason for Revision	Release Date
0	Original	17 December, 2007
1	Made edits to clarify plots per TCB request for clarification.	12 February, 2008

This report and the information contained herein represent the results of testing test articles identified and selected by the client performed to specifications and/or procedures selected by the client. National Technical Systems (NTS) makes no representations, expressed or implied, that such testing is adequate (or inadequate) to demonstrate efficiency, performance, reliability, or any other characteristic of the articles being tested, or similar products. This report should not be relied upon as an endorsement or certification by NTS of the equipment tested, nor does it represent any statement whatsoever as to its merchantability or fitness of the test article, or similar products, for a particular purpose. This report shall not be reproduced except in full.

INTRODUCTION

1.1 PURPOSE

The purpose of this document is to describe the tests applied by NTS Plano to demonstrate compliance of the MX8 Base Station Transceiver to FCC Part 27 Subparts C and M in accordance with the requirements of CFR 47, Part 2.

2.0 EUT DESCRIPTION

2.1 CONFIGURATION

Description of EUT

	Name	Model	Revision	Serial Number
EUT	2.5/2.6 GHz MX8 Base Station	2.5-2.6-BTS3A-R1 (AC Unit) 2.5-2.6-BTS3T-R1 (24 VDC Unit) 2.5-2.6-BTS3F-R1 (-48 VDC Unit)	P/N 92-92600- 00	064500002
RF Exposure Classification	Fixed. RF exposure is addressed at the time of licensing			
Channels/Frequency Range	2498.75 – 2687.25 MHz tuning, 2496 – 2690 MHz Authorized Band			
Power	+42.38 dBm (17.2 watts) max. peak power			
Modulation:	OFDMA (16QAM, 64 QAM, or QPSK), CDMA			
Emission Designator:	5M00F9W, 5M00W7D			
TX antenna details	Antenna is specified at time of licensing			
Functional Description	The MX8 Base Station Transceiver operates in a broadband wireless network to allow the user to access high speed data networks.			

2.1.1 EUT POWER

Voltage	120 Vac, 60 Hz
Number of Feeds	Single phase (L1 and Neutral)

This report and the information contained herein represent the results of testing test articles identified and selected by the client performed to specifications and/or procedures selected by the client. National Technical Systems (NTS) makes no representations, expressed or implied, that such testing is adequate (or inadequate) to demonstrate efficiency, performance, reliability, or any other characteristic of the articles being tested, or similar products. This report should not be relied upon as an endorsement or certification by NTS of the equipment tested, nor does it represent any statement whatsoever as to its merchantability or fitness of the test article, or similar products, for a particular purpose. This report shall not be reproduced except in full.

2.2 EUT CABLES

Quantity	Model/Type	Routing		Shielded / Unshielded	Description	Cable Length (m)
		From	To			
1	Ethernet	EUT	Support computer	Shielded	CAT 5 cable	2
1	Power cable	Power supply	EUT	Unshielded	Permanently connected to PS	1

2.3 MODE OF OPERATION DURING TESTS

Frequencies: 2498.75 MHz, 2597.5 MHz, 2687.25 MHz

Modulation Mode: CDMA and OFDMA (Orthogonal Frequency Division Multiple Access) QPSK. These modes were determined to produce worst-case results based on pre-testing.

This report and the information contained herein represent the results of testing test articles identified and selected by the client performed to specifications and/or procedures selected by the client. National Technical Systems (NTS) makes no representations, expressed or implied, that such testing is adequate (or inadequate) to demonstrate efficiency, performance, reliability, or any other characteristic of the articles being tested, or similar products. This report should not be relied upon as an endorsement or certification by NTS of the equipment tested, nor does it represent any statement whatsoever as to its merchantability or fitness of the test article, or similar products, for a particular purpose. This report shall not be reproduced except in full.

NTS Plano, 1701 E. Plano Pkwy., Plano, TX 75074 Tel: (972) 509-2566, Fax: (972) 509-0073

3.0 SUPPORT EQUIPMENT

3.1 CONFIGURATION

The radio was activated using customer-supplied test software. The software allowed the test engineer to change modulation modes and data rates and transmit channel.

3.2 TEST BED/PERIPHERAL CABLES

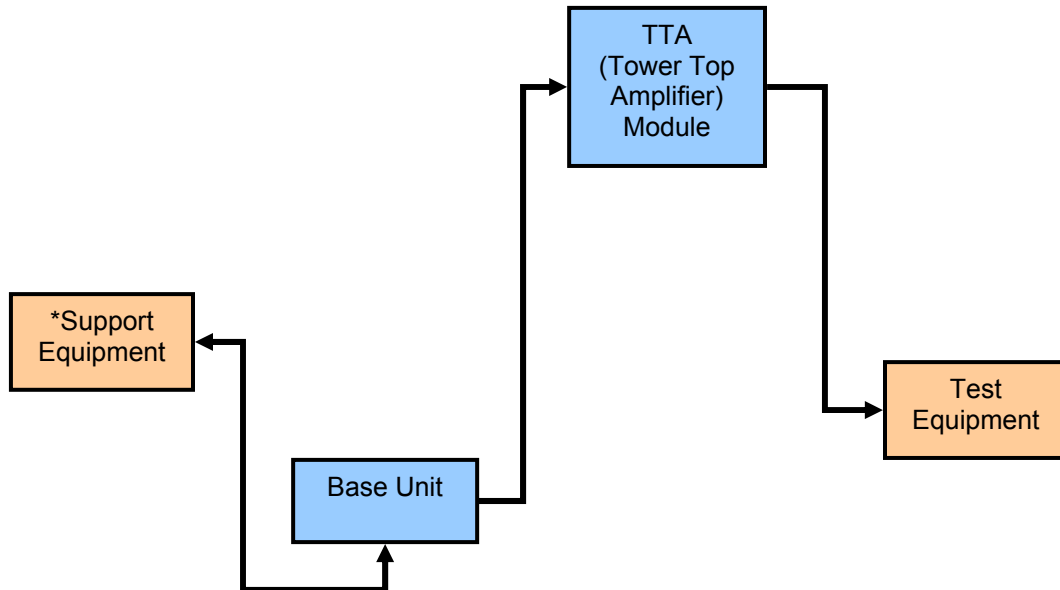

Support Equipment:

1. Hawking Technology Ethernet Switch, model # HFS5T;
2. Dell Laptop, model # Latitude C810.

This report and the information contained herein represent the results of testing test articles identified and selected by the client performed to specifications and/or procedures selected by the client. National Technical Systems (NTS) makes no representations, expressed or implied, that such testing is adequate (or inadequate) to demonstrate efficiency, performance, reliability, or any other characteristic of the articles being tested, or similar products. This report should not be relied upon as an endorsement or certification by NTS of the equipment tested, nor does it represent any statement whatsoever as to its merchantability or fitness of the test article, or similar products, for a particular purpose. This report shall not be reproduced except in full.

APPENDICES

This report and the information contained herein represent the results of testing test articles identified and selected by the client performed to specifications and/or procedures selected by the client. National Technical Systems (NTS) makes no representations, expressed or implied, that such testing is adequate (or inadequate) to demonstrate efficiency, performance, reliability, or any other characteristic of the articles being tested, or similar products. This report should not be relied upon as an endorsement or certification by NTS of the equipment tested, nor does it represent any statement whatsoever as to its merchantability or fitness of the test article, or similar products, for a particular purpose. This report shall not be reproduced except in full.

NTS Plano, 1701 E. Plano Pkwy., Plano, TX 75074 Tel: (972) 509-2566, Fax: (972) 509-0073

APPENDIX A: 2.1046 RF POWER OUTPUT

A.1. Base Standard & Test Basis

Base Standard	FCC PART 2.1046
Test Basis	TIA 603-C, 2004
Test Method	TIA 603-C, 2004

A.2. Specifications

27.50 Power and antenna height requirements

(h) The following power limits shall apply in the BRS and EBS:

(1) *Main, booster and base stations.* (i) The maximum EIRP of a main, booster or base station shall not exceed $33 \text{ dBW} + 10\log(X/Y) \text{ dBW}$, where X is the actual channel width in MHz and Y is either 6 MHz if prior to transition or the station is in the MBS following transition or 5.5 MHz if the station is in the LBS and UBS following transition, except as provided in paragraph (h)(1)(ii) of this section.

(ii) If a main or booster station sectorizes or otherwise uses one or more transmitting antennas with a non-omnidirectional horizontal plane radiation pattern, the maximum EIRP in dBW in a given direction shall be determined by the following formula: $\text{EIRP} = 33 \text{ dBW} + 10 \log(X/Y) \text{ dBW} + 10 \log(360/\text{beamwidth}) \text{ dBW}$, where X is the actual channel width in MHz, Y is either (i) 6 MHz if prior to transition or the station is in the MBS following transition or (ii) 5.5 MHz if the station is in the LBS and UBS following transition, and beamwidth is the total horizontal plane beamwidth of the individual transmitting antenna for the station or any sector measured at the half-power points.

(2) *Mobile and other user stations.* Mobile stations are limited to 2.0 watts EIRP. All user stations are limited to 2.0 watts transmitter output power.

(i) Peak transmit power shall be measured over any interval of continuous transmission using instrumentation calibrated in terms of rms-equivalent voltage. The measurement results shall be properly adjusted for any instrument limitations, such as detector response times, limited resolution bandwidth capability when compared to the emission bandwidth, etc., so as to obtain a true peak measurement for the emission in question over the full bandwidth of the channel.

Applicable RF Power Limit from Above: $33 \text{ dBW} + 10\log(X/Y)$ where X = 5 MHz and Y = 6 MHz.
 $+32.2 \text{ dBW} = 1660 \text{ watts eirp}$

This report and the information contained herein represent the results of testing test articles identified and selected by the client performed to specifications and/or procedures selected by the client. National Technical Systems (NTS) makes no representations, expressed or implied, that such testing is adequate (or inadequate) to demonstrate efficiency, performance, reliability, or any other characteristic of the articles being tested, or similar products. This report should not be relied upon as an endorsement or certification by NTS of the equipment tested, nor does it represent any statement whatsoever as to its merchantability or fitness of the test article, or similar products, for a particular purpose. This report shall not be reproduced except in full.

A.3. Deviations

Deviation Number	Time & Date	Description and Justification of Deviation	Deviation Reference			Approval
			Base Standard	Test Basis	NTS Procedure	
None						

A.4. Test Procedure

TIA 603-C, 2004 and 27.50(h)(2)(i). The measurement was made using a spectrum analyzer with peak detector. The channel power measurement feature on the spectrum analyzer was used to perform the measurement. The resolution bandwidth was set to 50 kHz, Video bandwidth was set to 100 kHz. The channel width was defined as 5 MHz.

A.5. Test Results

The EUT is in compliance with the limits as specified above. The maximum rf output power at the antenna terminals is +32.26 dBm (average) or 42.38 dBm (peak).

A.6. Operating Mode During Test

The transmitter was tested while in a continuous transmit mode. The EUT was tuned to a low, middle, and high channel..

A.7. Sample Calculation

$$\text{Rf power(watts)} = 10^{(\text{rf power(dBm)}/10)} / 1000$$

A.8. Test Data

Channel	Modulation Mode	Avg. RF Power Output at Antenna Terminals (dBm)	Peak RF Power Output at Antenna Terminals (dBm)
2498.75 MHz	OFDMA	32.08	41.39
2597.50 MHz	OFDMA	31.91	41.20
2687.25 MHz	OFDMA	31.86	41.27
2498.75 MHz	CDMA	32.26	42.38
2597.50 MHz	CDMA	31.98	41.97
2687.25 MHz	CDMA	32.18	42.07

NOTE: The rf power output was measured with the device in continuous transmit mode. A reading was taken with both peak and average detector.

Test Date: 14 December, 2007

Tested by: Dwaine Hartman, Wireless Technician

This report and the information contained herein represent the results of testing test articles identified and selected by the client performed to specifications and/or procedures selected by the client. National Technical Systems (NTS) makes no representations, expressed or implied, that such testing is adequate (or inadequate) to demonstrate efficiency, performance, reliability, or any other characteristic of the articles being tested, or similar products. This report should not be relied upon as an endorsement or certification by NTS of the equipment tested, nor does it represent any statement whatsoever as to its merchantability or fitness of the test article, or similar products, for a particular purpose. This report shall not be reproduced except in full.

A.9. Test Diagram

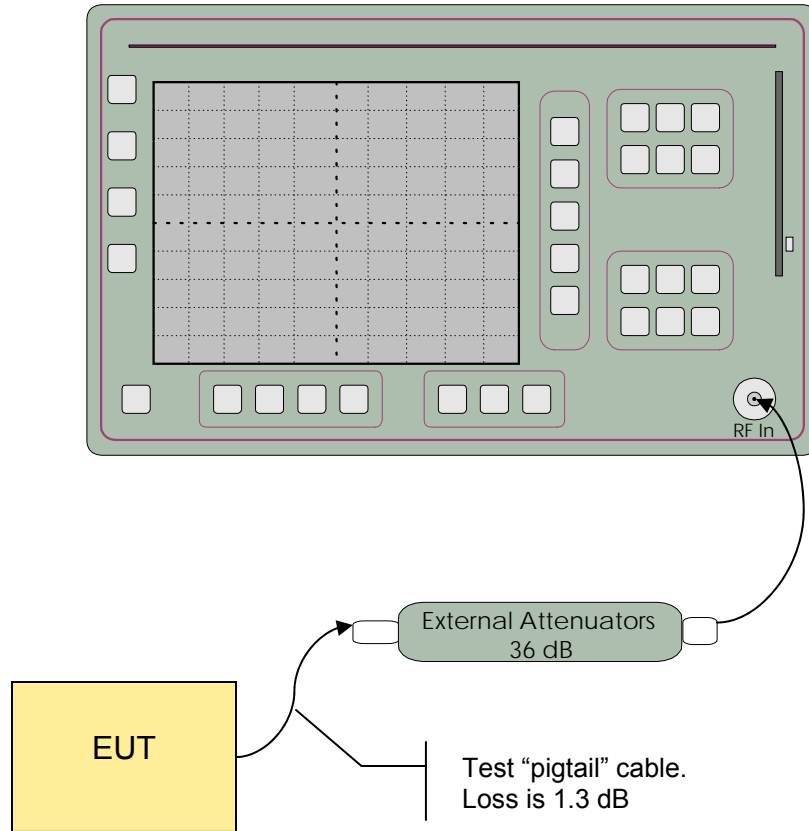

A.10. Tested By

Test Date: 12 December, 2007

Tested by: Dwaine Hartman, Wireless Technician

This report and the information contained herein represent the results of testing test articles identified and selected by the client performed to specifications and/or procedures selected by the client. National Technical Systems (NTS) makes no representations, expressed or implied, that such testing is adequate (or inadequate) to demonstrate efficiency, performance, reliability, or any other characteristic of the articles being tested, or similar products. This report should not be relied upon as an endorsement or certification by NTS of the equipment tested, nor does it represent any statement whatsoever as to its merchantability or fitness of the test article, or similar products, for a particular purpose. This report shall not be reproduced except in full.

APPENDIX B: 2.1047 MODULATION CHARACTERISTICS

B.1. Base Standard & Test Basis

Base Standard	FCC 2.1047
Test Basis	FCC 2.1047 Modulation Characteristics
Test Method	TIA 603-C, 2004

B.2. Specifications

2.1047 – Modulation Characteristics

(a) *Voice modulated communication equipment.* A curve or equivalent data showing the frequency response of the audio modulating circuit over a range of 100 to 5000 Hz shall be submitted. For equipment required to have an audio low-pass filter, a curve showing the frequency response of the filter, or of all circuitry installed between the modulation limiter and the modulated stage shall be submitted.

(b) *Equipment which employs modulation limiting.* A curve or family of curves showing the percentage of modulation versus the modulation input voltage shall be supplied. The information submitted shall be sufficient to show modulation limiting capability throughout the range of modulating frequencies and input modulating signal levels employed.

(c) *Single sideband and independent sideband radiotelephone transmitters which employ a device or circuit to limit peak envelope power.* A curve showing the peak envelope power output versus the modulation input voltage shall be supplied. The modulating signals shall be the same in frequency as specified in paragraph (c) of §2.1049 for the occupied bandwidth tests.

(d) *Other types of equipment.* A curve or equivalent data which shows that the equipment will meet the modulation requirements of the rules under which the equipment is to be licensed.

B.3. Deviations

Deviation Number	Time & Date	Description and Justification of Deviation	Deviation Reference			Approval
			Base Standard	Test Basis	NTS Procedure	
none						

B.4. Test Method

This device generates a complex digitally modulated waveform.

This report and the information contained herein represent the results of testing test articles identified and selected by the client performed to specifications and/or procedures selected by the client. National Technical Systems (NTS) makes no representations, expressed or implied, that such testing is adequate (or inadequate) to demonstrate efficiency, performance, reliability, or any other characteristic of the articles being tested, or similar products. This report should not be relied upon as an endorsement or certification by NTS of the equipment tested, nor does it represent any statement whatsoever as to its merchantability or fitness of the test article, or similar products, for a particular purpose. This report shall not be reproduced except in full.

B.5. Test Results

Not applicable – The device does not produce an analogue modulated waveform.

Test Data Summary

Emission Designators

5M00F9W
5M00W7D

B.6. Test Diagram

N/A

B.7. Tested By

Test Date: 12 December, 2007

Tested by: Dwaine Hartman, Wireless Technician

This report and the information contained herein represent the results of testing test articles identified and selected by the client performed to specifications and/or procedures selected by the client. National Technical Systems (NTS) makes no representations, expressed or implied, that such testing is adequate (or inadequate) to demonstrate efficiency, performance, reliability, or any other characteristic of the articles being tested, or similar products. This report should not be relied upon as an endorsement or certification by NTS of the equipment tested, nor does it represent any statement whatsoever as to its merchantability or fitness of the test article, or similar products, for a particular purpose. This report shall not be reproduced except in full.

APPENDIX C: 2.10.49 OCCUPIED BANDWIDTH

C.1. Base Standard & Test Basis

Base Standard	FCC 2.1049
Test Basis	FCC 2.1049 Occupied Bandwidth
Test Method	TIA 603-C, 2004

C.2. Specifications

27.53(l)

(1) Prior to the transition, and thereafter, solely within the MBS, for analog operations with an EIRP in excess of -9 dBW, the signal shall be attenuated at the channel edges by at least 38 dB relative to the peak visual carrier, then linearly sloping from that level to at least 60 dB of attenuation at 1 MHz below the lower band edge and 0.5 MHz above the upper band edge, and attenuated at least 60 dB at all other frequencies.

(2) **For fixed and temporary fixed digital stations, the attenuation shall be not less than $43 + 10 \log(P)$ dB**, unless a documented interference complaint is received from an adjacent channel licensee. Provided that the complaint cannot be mutually resolved between the parties, both licensees of existing and new systems shall reduce their out-of-band emissions by at least $67 + 10 \log(P)$ dB measured at 3 MHz from their channel's edges for distances between stations exceeding 1.5 km. For stations separated by less than 1.5 km, the new licensee shall reduce attenuation at least $67 + 10 \log(P) - 20 \log(D\text{km}/1.5)$, or when colocated, limit the undesired signal level at the affected licensee's base station receiver(s) at the collocation site to no more than -107 dBm. Mobile Service Satellite licensees operating on frequencies below 2495 MHz may also submit a documented interference complaint against BRS licensees operating on channel BRS1 on the same terms and conditions as adjacent channel BRS or EBS licensees.

(3) Prior to transition and thereafter solely within the MBS, and notwithstanding paragraph (l)(2) of this section, the maximum out-of-band power of a digital transmitter operating on a single 6 MHz channel with an EIRP in excess of -9 dBW employing digital modulation for the primary purpose of transmitting video programming shall be attenuated at the 6 MHz channel edges at least 25 dB relative to the licensed average 6 MHz channel power level, then attenuated along a linear slope to at least 40 dB at 250 kHz beyond the nearest channel edge, then attenuated along a linear slope from that level to at least 60 dB at 3 MHz above the upper and below the lower licensed channel edges, and attenuated at least 60 dB at all other frequencies.

(4) For mobile digital stations, the attenuation factor shall be not less than $43 + 10 \log(P)$ dB at the channel edge and $55 + 10 \log(P)$ dB at 5.5 MHz from the channel edges. Mobile Service Satellite licensees operating on frequencies below 2495 MHz may also submit a documented interference complaint against BRS licensees operating on channel BRS1 on the same terms and conditions as adjacent channel BRS or EBS licensees.

(5) Notwithstanding the provisions of paragraphs (l)(2) and (l)(4) of this section, prior to transition, a licensee may continue to operate facilities deployed as of January 10, 2005 provided that such facilities operate in compliance with the emission mask applicable to those services prior to January 10, 2005.

(6) Measurement procedure. Compliance with these rules is based on the use of measurement instrumentation employing a resolution bandwidth of 1 MHz or greater. However, in the 1 MHz bands immediately outside and adjacent to the frequency block a resolution bandwidth of at least one percent of the emission bandwidth of the fundamental emission of the transmitter may be employed. A narrower resolution bandwidth is permitted in all cases to improve measurement accuracy provided the measured power is integrated over the full required measurement bandwidth (*i.e.* 1 MHz or 1 percent of emission bandwidth, as specified). The emission bandwidth is defined as the width of the signal between two points, one below the carrier center frequency and one above the carrier center frequency, outside of

This report and the information contained herein represent the results of testing test articles identified and selected by the client performed to specifications and/or procedures selected by the client. National Technical Systems (NTS) makes no representations, expressed or implied, that such testing is adequate (or inadequate) to demonstrate efficiency, performance, reliability, or any other characteristic of the articles being tested, or similar products. This report should not be relied upon as an endorsement or certification by NTS of the equipment tested, nor does it represent any statement whatsoever as to its merchantability or fitness of the test article, or similar products, for a particular purpose. This report shall not be reproduced except in full.

which all emissions are attenuated at least 26 dB below the transmitter power. With respect to television operations, measurements must be made of the separate visual and aural operating powers at sufficiently frequent intervals to ensure compliance with the rules.

C.3. Deviations

Deviation Number	Time & Date	Description and Justification of Deviation	Deviation Reference			Approval
			Base Standard	Test Basis	NTS Procedure	
none						

C.4. Test Method

TIA 603-C, 2004 and 27.53(l)(6)

C.5. Test Results

The 26 dB bandwidth is 5.07 MHz in full bandwidth mode.

C.6. Deviations from Normal Operating Mode During Test

None.

C.7. Sample Calculation

N/A

C.8. Test Data

See plots following.

This report and the information contained herein represent the results of testing test articles identified and selected by the client performed to specifications and/or procedures selected by the client. National Technical Systems (NTS) makes no representations, expressed or implied, that such testing is adequate (or inadequate) to demonstrate efficiency, performance, reliability, or any other characteristic of the articles being tested, or similar products. This report should not be relied upon as an endorsement or certification by NTS of the equipment tested, nor does it represent any statement whatsoever as to its merchantability or fitness of the test article, or similar products, for a particular purpose. This report shall not be reproduced except in full.

Figure 1 26 dB BW - 2498.75 MHz (OFDMA Mode)

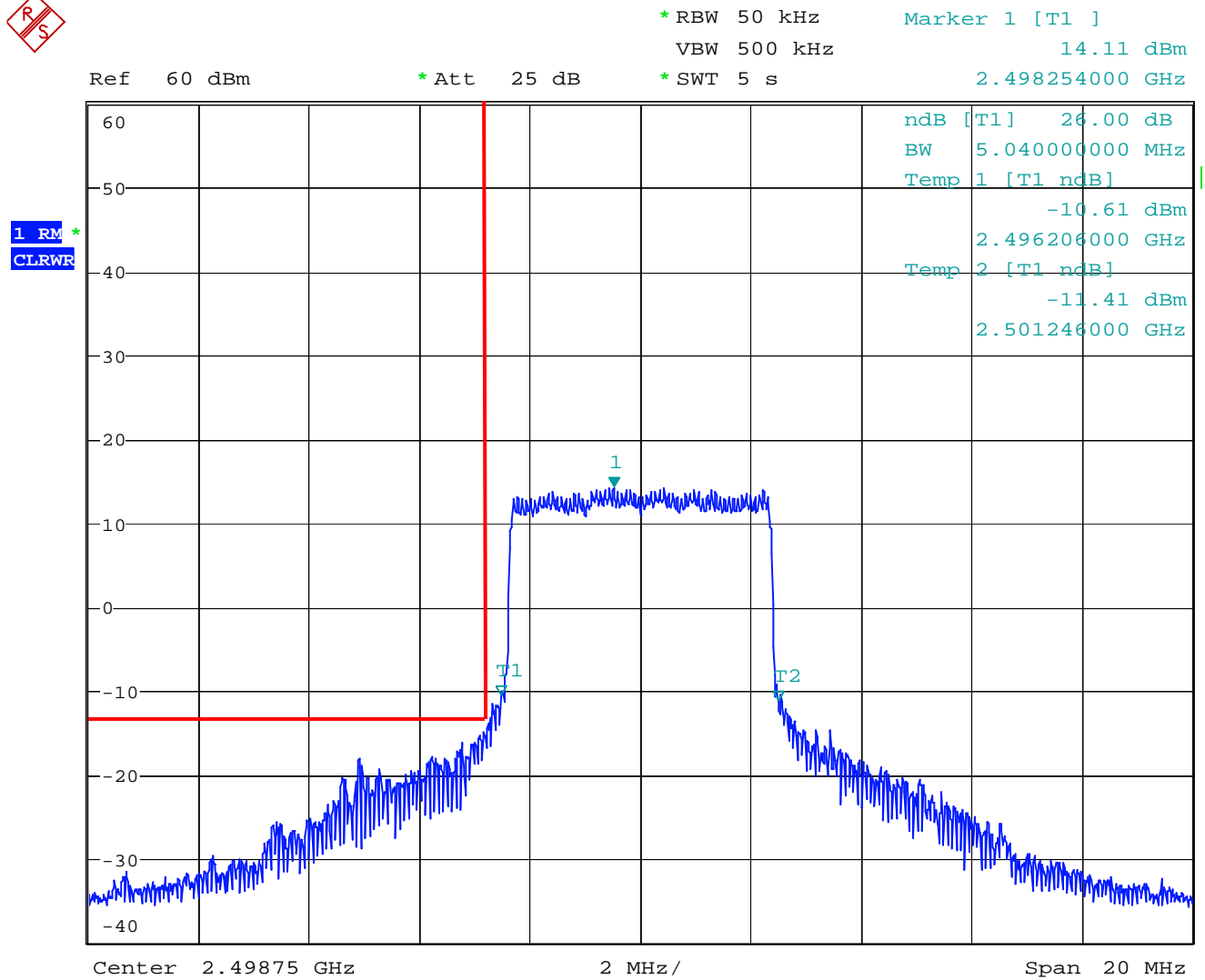

Date: 12.DEC.2007 09:12:00

This report and the information contained herein represent the results of testing test articles identified and selected by the client performed to specifications and/or procedures selected by the client. National Technical Systems (NTS) makes no representations, expressed or implied, that such testing is adequate (or inadequate) to demonstrate efficiency, performance, reliability, or any other characteristic of the articles being tested, or similar products. This report should not be relied upon as an endorsement or certification by NTS of the equipment tested, nor does it represent any statement whatsoever as to its merchantability or fitness of the test article, or similar products, for a particular purpose. This report shall not be reproduced except in full.

Figure 2 26 dB BW - 2597.50 MHz (OFDMA Mode)



1 RM *
CLRWR

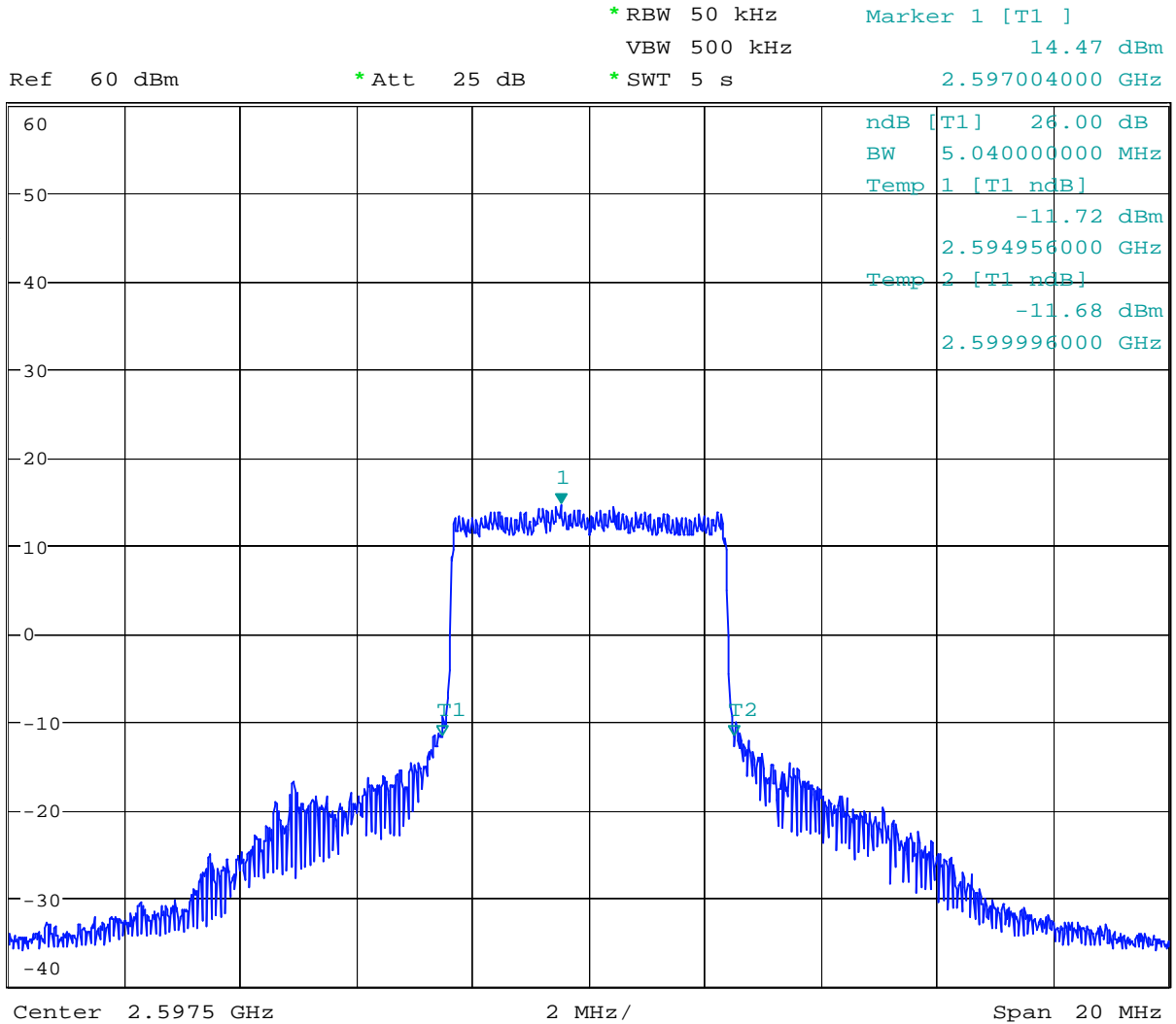

Date: 12.DEC.2007 09:19:38

This report and the information contained herein represent the results of testing test articles identified and selected by the client performed to specifications and/or procedures selected by the client. National Technical Systems (NTS) makes no representations, expressed or implied, that such testing is adequate (or inadequate) to demonstrate efficiency, performance, reliability, or any other characteristic of the articles being tested, or similar products. This report should not be relied upon as an endorsement or certification by NTS of the equipment tested, nor does it represent any statement whatsoever as to its merchantability or fitness of the test article, or similar products, for a particular purpose. This report shall not be reproduced except in full.

Figure 3 26 dB BW - 2687.25 MHz (OFDMA Mode)

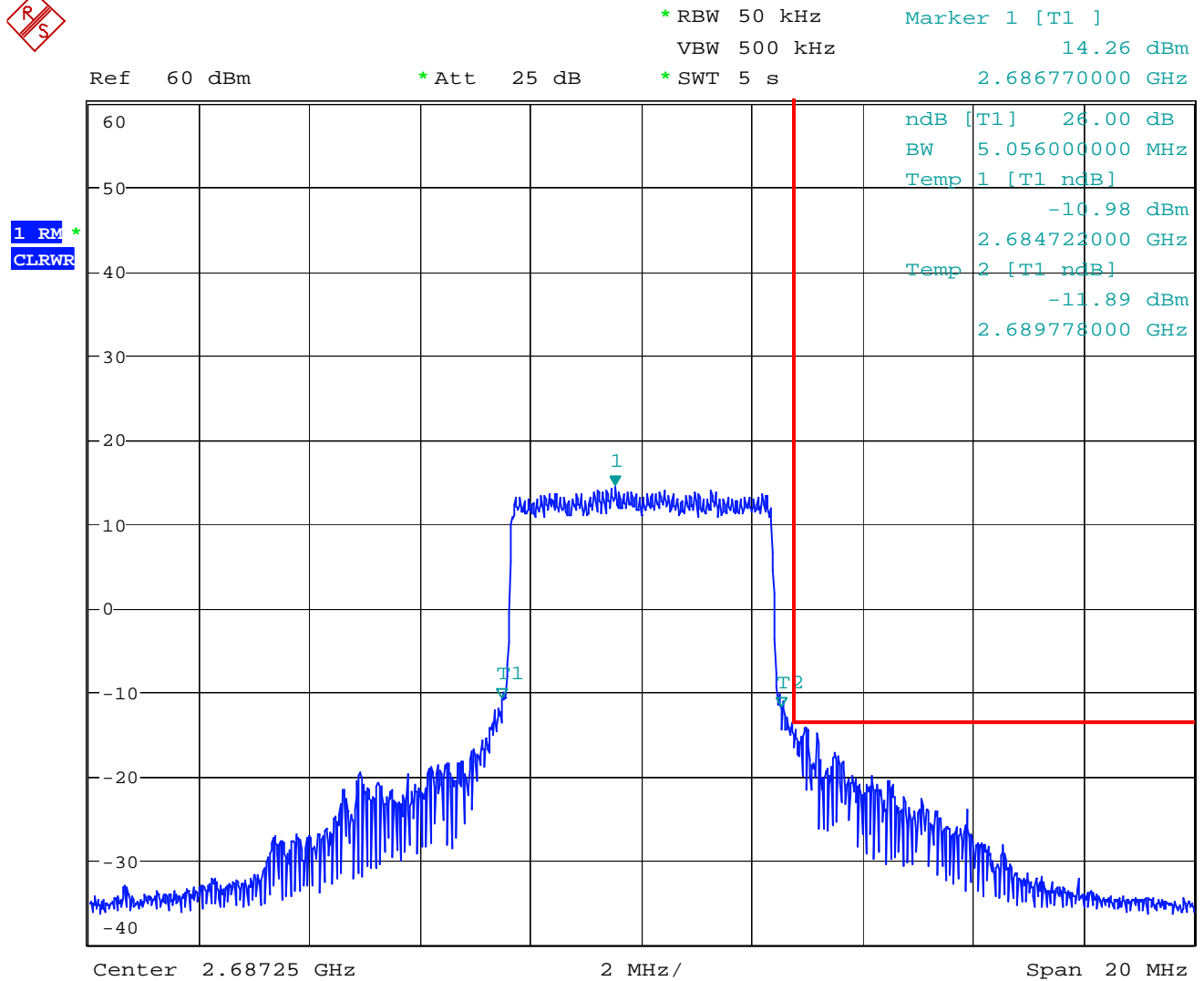

Date: 12.DEC.2007 09:25:44

This report and the information contained herein represent the results of testing test articles identified and selected by the client performed to specifications and/or procedures selected by the client. National Technical Systems (NTS) makes no representations, expressed or implied, that such testing is adequate (or inadequate) to demonstrate efficiency, performance, reliability, or any other characteristic of the articles being tested, or similar products. This report should not be relied upon as an endorsement or certification by NTS of the equipment tested, nor does it represent any statement whatsoever as to its merchantability or fitness of the test article, or similar products, for a particular purpose. This report shall not be reproduced except in full.

Figure 4 26 dB BW - 2498.75 MHz (CDMA Mode)

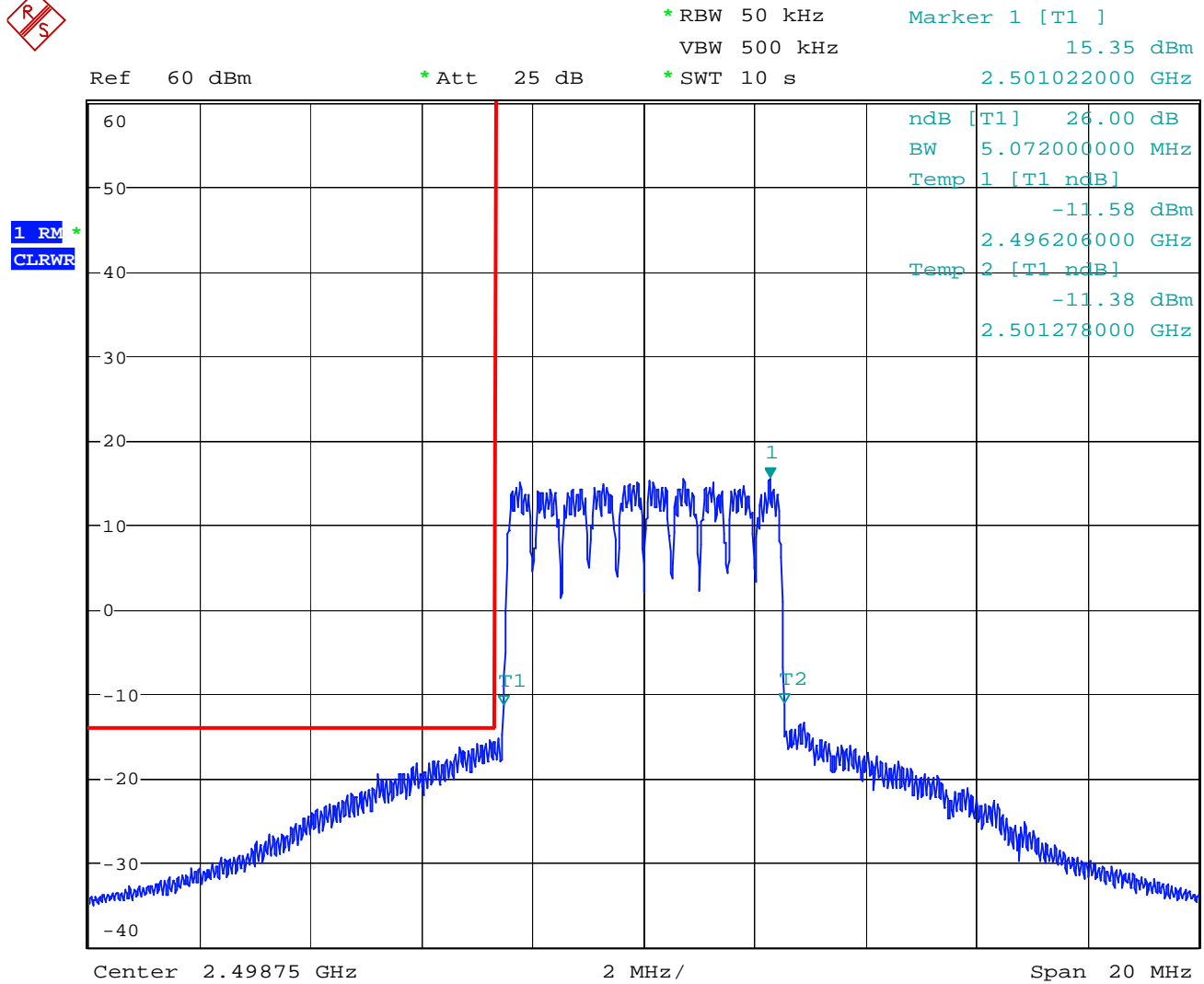

Date: 12.DEC.2007 15:34:13

This report and the information contained herein represent the results of testing test articles identified and selected by the client performed to specifications and/or procedures selected by the client. National Technical Systems (NTS) makes no representations, expressed or implied, that such testing is adequate (or inadequate) to demonstrate efficiency, performance, reliability, or any other characteristic of the articles being tested, or similar products. This report should not be relied upon as an endorsement or certification by NTS of the equipment tested, nor does it represent any statement whatsoever as to its merchantability or fitness of the test article, or similar products, for a particular purpose. This report shall not be reproduced except in full.

Figure 5 26 dB BW - 2597.50 MHz (CDMA Mode)



1 RM *
CLRWR

* RBW 50 kHz Marker 1 [T1]
 VBW 500 kHz 15.09 dBm
 * Att 25 dB * SWT 10 s 2.595244000 GHz

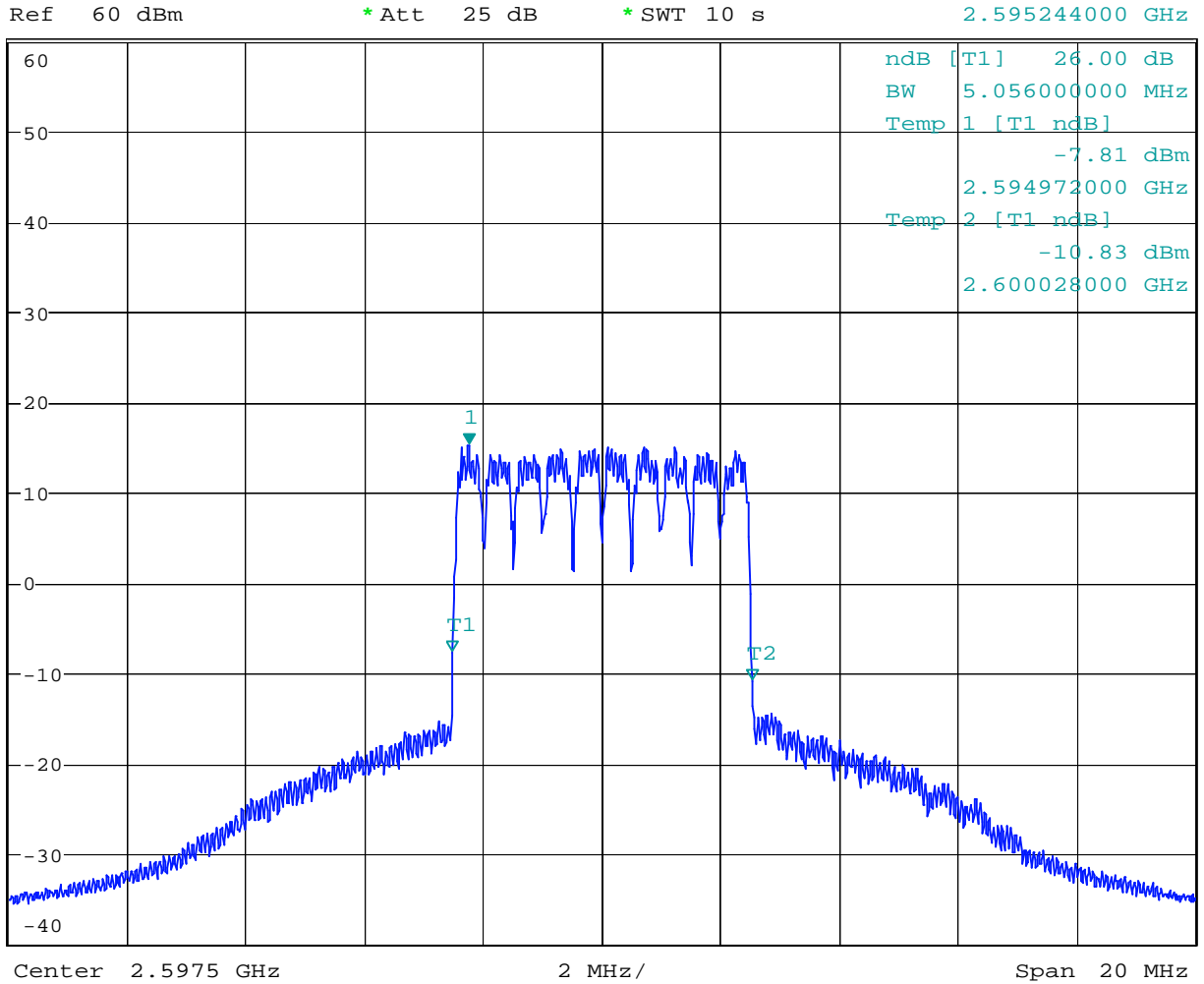

Date: 12.DEC.2007 15:42:39

This report and the information contained herein represent the results of testing test articles identified and selected by the client performed to specifications and/or procedures selected by the client. National Technical Systems (NTS) makes no representations, expressed or implied, that such testing is adequate (or inadequate) to demonstrate efficiency, performance, reliability, or any other characteristic of the articles being tested, or similar products. This report should not be relied upon as an endorsement or certification by NTS of the equipment tested, nor does it represent any statement whatsoever as to its merchantability or fitness of the test article, or similar products, for a particular purpose. This report shall not be reproduced except in full.

Figure 6 26 dB BW - 2687.25 MHz (CDMA Mode)



* RBW 50 kHz Marker 1 [T1]
 VBW 500 kHz 15.27 dBm
 * Att 25 dB * SWT 10 s 2.687954000 GHz

1 RM *
 CLRWR

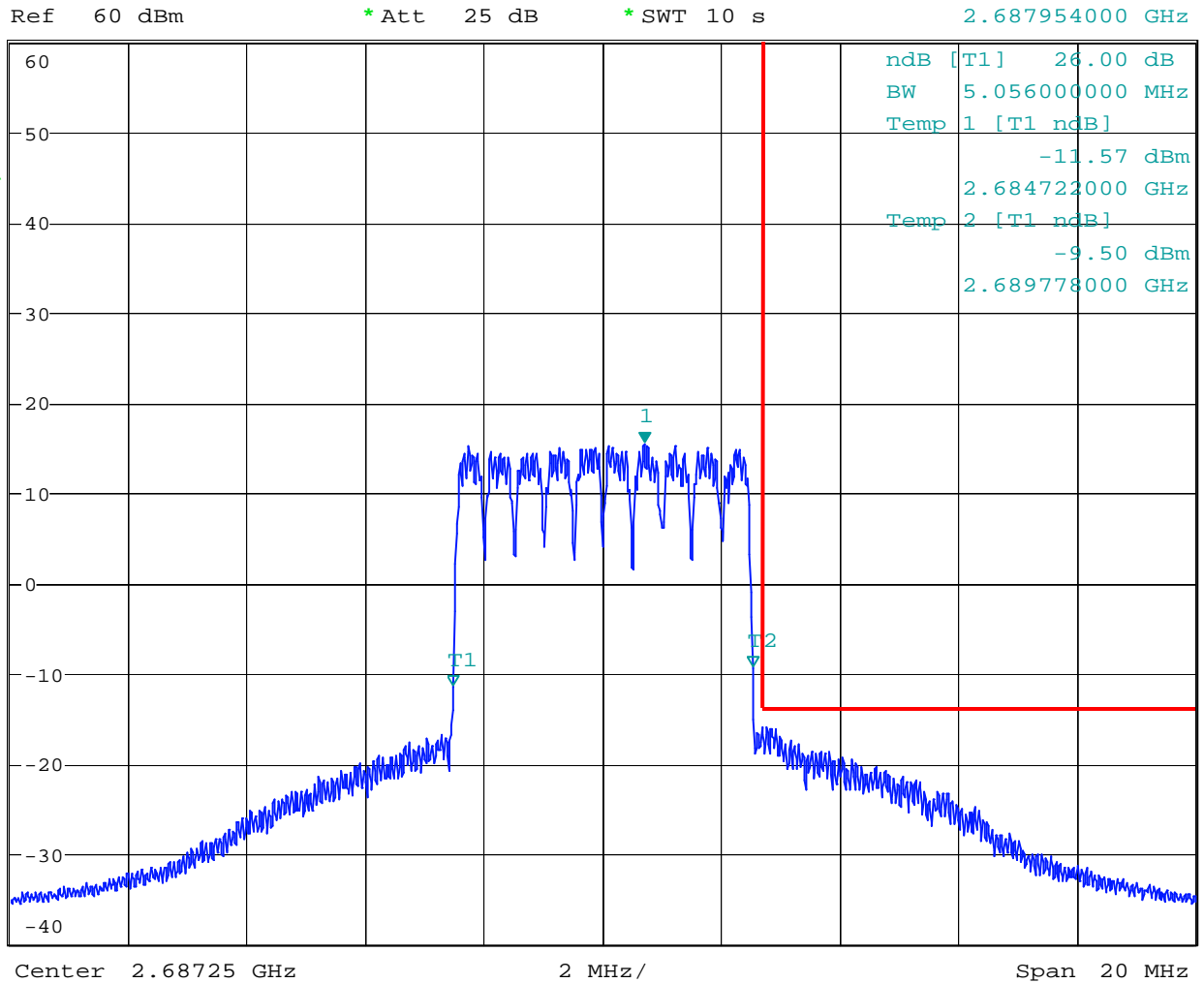

Date: 12.DEC.2007 15:52:58

This report and the information contained herein represent the results of testing test articles identified and selected by the client performed to specifications and/or procedures selected by the client. National Technical Systems (NTS) makes no representations, expressed or implied, that such testing is adequate (or inadequate) to demonstrate efficiency, performance, reliability, or any other characteristic of the articles being tested, or similar products. This report should not be relied upon as an endorsement or certification by NTS of the equipment tested, nor does it represent any statement whatsoever as to its merchantability or fitness of the test article, or similar products, for a particular purpose. This report shall not be reproduced except in full.

C.9. Test Diagram

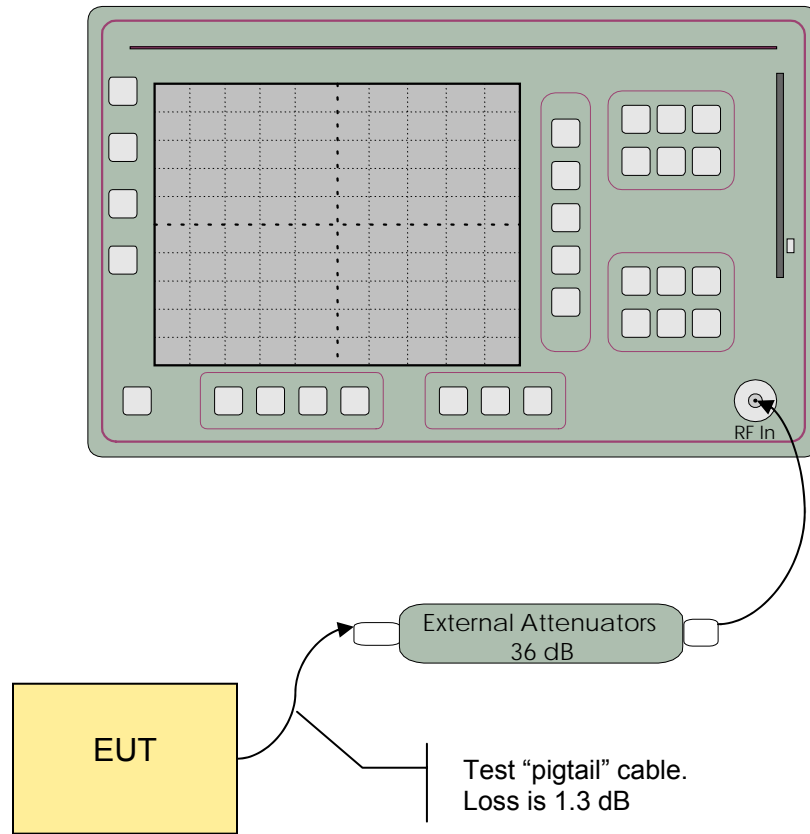

C.10. Tested By

Test Date: 12 December, 2007

Tested by: Dwaine Hartman, Wireless Technician

This report and the information contained herein represent the results of testing test articles identified and selected by the client performed to specifications and/or procedures selected by the client. National Technical Systems (NTS) makes no representations, expressed or implied, that such testing is adequate (or inadequate) to demonstrate efficiency, performance, reliability, or any other characteristic of the articles being tested, or similar products. This report should not be relied upon as an endorsement or certification by NTS of the equipment tested, nor does it represent any statement whatsoever as to its merchantability or fitness of the test article, or similar products, for a particular purpose. This report shall not be reproduced except in full.

APPENDIX D: 2.1051 SPURIOUS EMISSIONS AT ANTENNA TERMINALS

D.1. Base Standard & Test Basis

Base Standard	FCC 2.1051
Test Basis	FCC 2.1051 Spurious Emissions at Antenna Terminals
Test Method	TIA 603-C, 2004

D.2. Specifications

27.53(l)

(1) Prior to the transition, and thereafter, solely within the MBS, for analog operations with an EIRP in excess of -9 dBW, the signal shall be attenuated at the channel edges by at least 38 dB relative to the peak visual carrier, then linearly sloping from that level to at least 60 dB of attenuation at 1 MHz below the lower band edge and 0.5 MHz above the upper band edge, and attenuated at least 60 dB at all other frequencies.

(2) **For fixed and temporary fixed digital stations, the attenuation shall be not less than $43 + 10 \log(P)$ dB**, unless a documented interference complaint is received from an adjacent channel licensee. Provided that the complaint cannot be mutually resolved between the parties, both licensees of existing and new systems shall reduce their out-of-band emissions by at least $67 + 10 \log(P)$ dB measured at 3 MHz from their channel's edges for distances between stations exceeding 1.5 km. For stations separated by less than 1.5 km, the new licensee shall reduce attenuation at least $67 + 10 \log(P) - 20 \log(D\text{km}/1.5)$, or when collocated, limit the undesired signal level at the affected licensee's base station receiver(s) at the collocation site to no more than -107 dBm. Mobile Service Satellite licensees operating on frequencies below 2495 MHz may also submit a documented interference complaint against BRS licensees operating on channel BRS1 on the same terms and conditions as adjacent channel BRS or EBS licensees.

(3) Prior to transition and thereafter solely within the MBS, and notwithstanding paragraph (l)(2) of this section, the maximum out-of-band power of a digital transmitter operating on a single 6 MHz channel with an EIRP in excess of -9 dBW employing digital modulation for the primary purpose of transmitting video programming shall be attenuated at the 6 MHz channel edges at least 25 dB relative to the licensed average 6 MHz channel power level, then attenuated along a linear slope to at least 40 dB at 250 kHz beyond the nearest channel edge, then attenuated along a linear slope from that level to at least 60 dB at 3 MHz above the upper and below the lower licensed channel edges, and attenuated at least 60 dB at all other frequencies.

(4) For mobile digital stations, the attenuation factor shall be not less than $43 + 10 \log(P)$ dB at the channel edge and $55 + 10 \log(P)$ dB at 5.5 MHz from the channel edges. Mobile Service Satellite licensees operating on frequencies below 2495 MHz may also submit a documented interference complaint against BRS licensees operating on channel BRS1 on the same terms and conditions as adjacent channel BRS or EBS licensees.

(5) Notwithstanding the provisions of paragraphs (l)(2) and (l)(4) of this section, prior to transition, a licensee may continue to operate facilities deployed as of January 10, 2005 provided that such facilities operate in compliance with the emission mask applicable to those services prior to January 10, 2005.

(6) Measurement procedure. Compliance with these rules is based on the use of measurement instrumentation employing a resolution bandwidth of 1 MHz or greater. However, in the 1 MHz bands immediately outside and adjacent to the frequency block a resolution bandwidth of at least one percent of the emission bandwidth of the fundamental emission of the transmitter may be employed. A narrower resolution bandwidth is permitted in all cases to improve measurement accuracy provided the measured power is integrated over the full required measurement bandwidth (*i.e.* 1 MHz or 1 percent of emission

This report and the information contained herein represent the results of testing test articles identified and selected by the client performed to specifications and/or procedures selected by the client. National Technical Systems (NTS) makes no representations, expressed or implied, that such testing is adequate (or inadequate) to demonstrate efficiency, performance, reliability, or any other characteristic of the articles being tested, or similar products. This report should not be relied upon as an endorsement or certification by NTS of the equipment tested, nor does it represent any statement whatsoever as to its merchantability or fitness of the test article, or similar products, for a particular purpose. This report shall not be reproduced except in full.

bandwidth, as specified). **The emission bandwidth is defined as the width of the signal between two points, one below the carrier center frequency and one above the carrier center frequency, outside of which all emissions are attenuated at least 26 dB below the transmitter power.** With respect to television operations, measurements must be made of the separate visual and aural operating powers at sufficiently frequent intervals to ensure compliance with the rules.

D.3. Measurement Uncertainty

Expanded Uncertainty (K=2)
+1.11/-1.22

D.4. Deviations

Deviation Number	Time & Date	Description and Justification of Deviation	Deviation Reference			Approval
			Base Standard	Test Basis	NTS Procedure	
none						

D.5. Sample Calculation

43 + 10 log(P)
 43 + 10 log(2) = 46 dB
 +33 dBm – 46 dB = -13 dBm

D.6. Test Results

Complies. All emissions meet the out of band limits.

Out-of-Band Emissions limit is 43 + 10 log(P) which relates to -13 dBm absolute power.

This report and the information contained herein represent the results of testing test articles identified and selected by the client performed to specifications and/or procedures selected by the client. National Technical Systems (NTS) makes no representations, expressed or implied, that such testing is adequate (or inadequate) to demonstrate efficiency, performance, reliability, or any other characteristic of the articles being tested, or similar products. This report should not be relied upon as an endorsement or certification by NTS of the equipment tested, nor does it represent any statement whatsoever as to its merchantability or fitness of the test article, or similar products, for a particular purpose. This report shall not be reproduced except in full.

D.7. Test Diagram

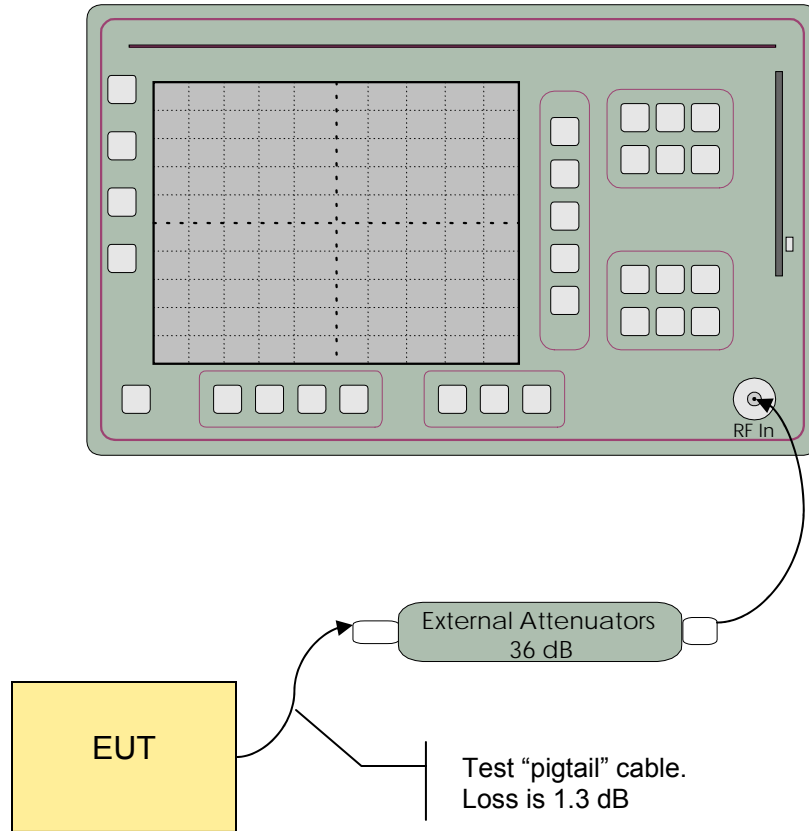

D.8. Test Data

See following pages.

This report and the information contained herein represent the results of testing test articles identified and selected by the client performed to specifications and/or procedures selected by the client. National Technical Systems (NTS) makes no representations, expressed or implied, that such testing is adequate (or inadequate) to demonstrate efficiency, performance, reliability, or any other characteristic of the articles being tested, or similar products. This report should not be relied upon as an endorsement or certification by NTS of the equipment tested, nor does it represent any statement whatsoever as to its merchantability or fitness of the test article, or similar products, for a particular purpose. This report shall not be reproduced except in full.



Figure 7 Lower Band Edge Spurious - 2496 MHz Band Edge (OFDMA Mode)

* RBW 10 kHz
VBW 100 kHz
* SWT 10 s

Ref 44 dBm

* Att 0 dB

* SWT 10 s

1 RM *
CLRWR

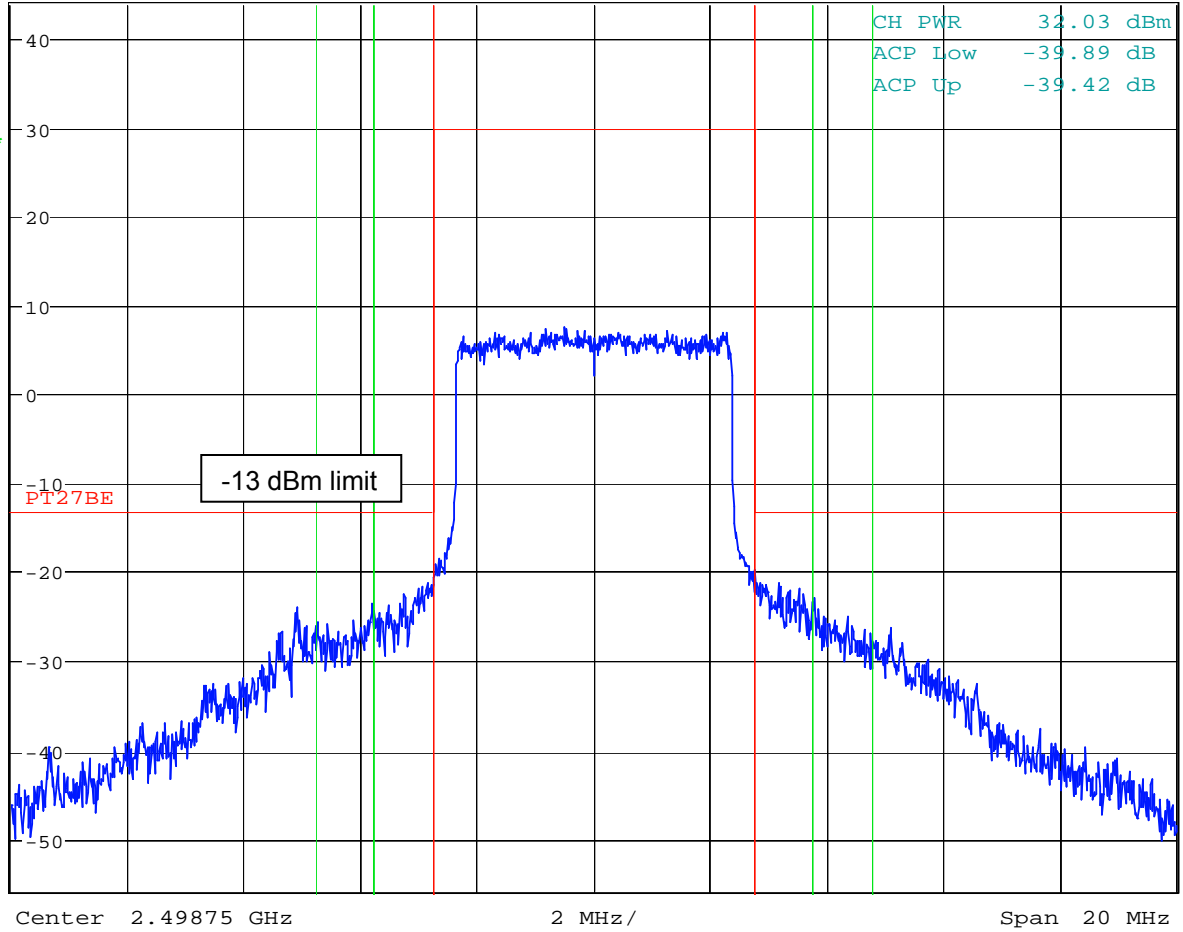

Date: 12.DEC.2007 09:07:47

This report and the information contained herein represent the results of testing test articles identified and selected by the client performed to specifications and/or procedures selected by the client. National Technical Systems (NTS) makes no representations, expressed or implied, that such testing is adequate (or inadequate) to demonstrate efficiency, performance, reliability, or any other characteristic of the articles being tested, or similar products. This report should not be relied upon as an endorsement or certification by NTS of the equipment tested, nor does it represent any statement whatsoever as to its merchantability or fitness of the test article, or similar products, for a particular purpose. This report shall not be reproduced except in full.

Figure 8 Spurious - 2597.50 MHz (OFDMA Mode)



* RBW 10 kHz
 * VBW 100 kHz
 * SWT 10 s

Ref 44 dBm

* Att 0 dB

1 RM *
 CLRWR

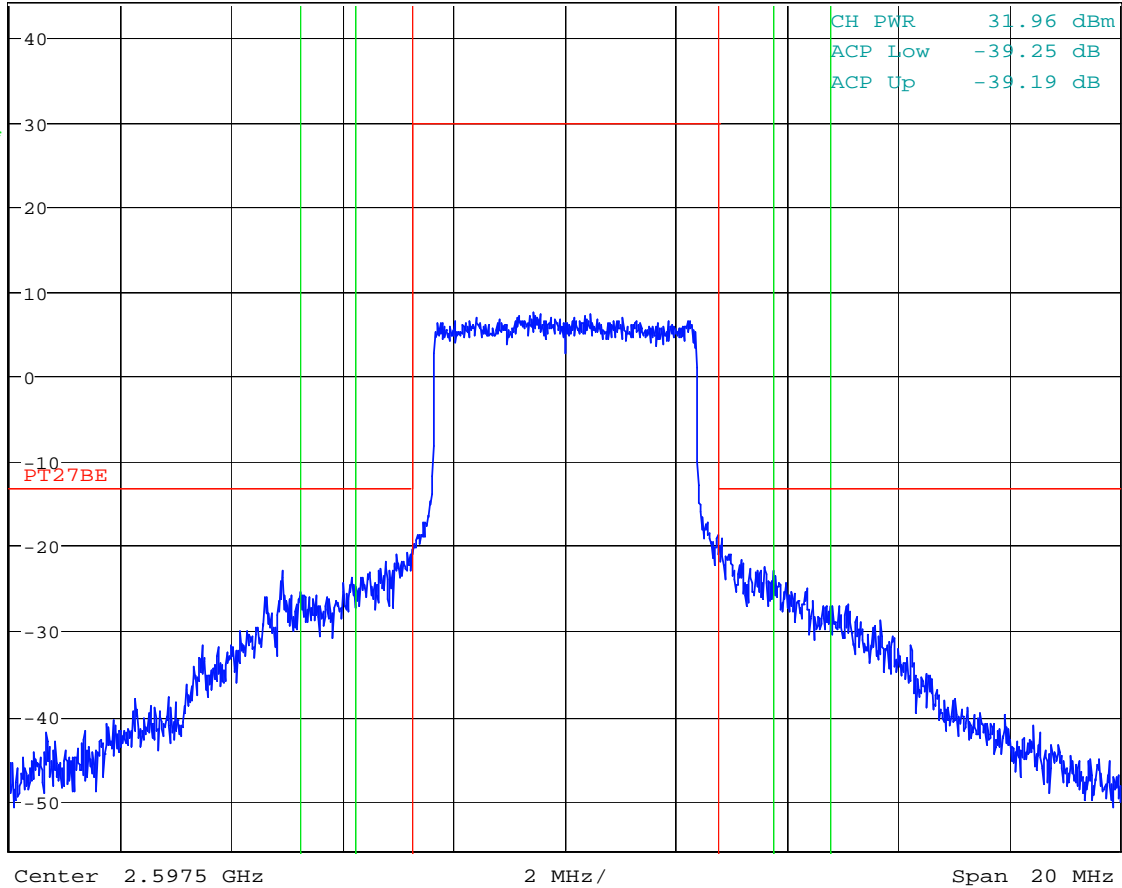

Date: 12.DEC.2007 09:18:37

This report and the information contained herein represent the results of testing test articles identified and selected by the client performed to specifications and/or procedures selected by the client. National Technical Systems (NTS) makes no representations, expressed or implied, that such testing is adequate (or inadequate) to demonstrate efficiency, performance, reliability, or any other characteristic of the articles being tested, or similar products. This report should not be relied upon as an endorsement or certification by NTS of the equipment tested, nor does it represent any statement whatsoever as to its merchantability or fitness of the test article, or similar products, for a particular purpose. This report shall not be reproduced except in full.

Figure 9 Upper Band Edge Spurious - 2690 MHz Band Edge (OFDMA Mode)



* RBW 10 kHz
 * VBW 100 kHz
 * SWT 10 s

Ref 44 dBm

* Att 0 dB

1 RM *
 CLRWR

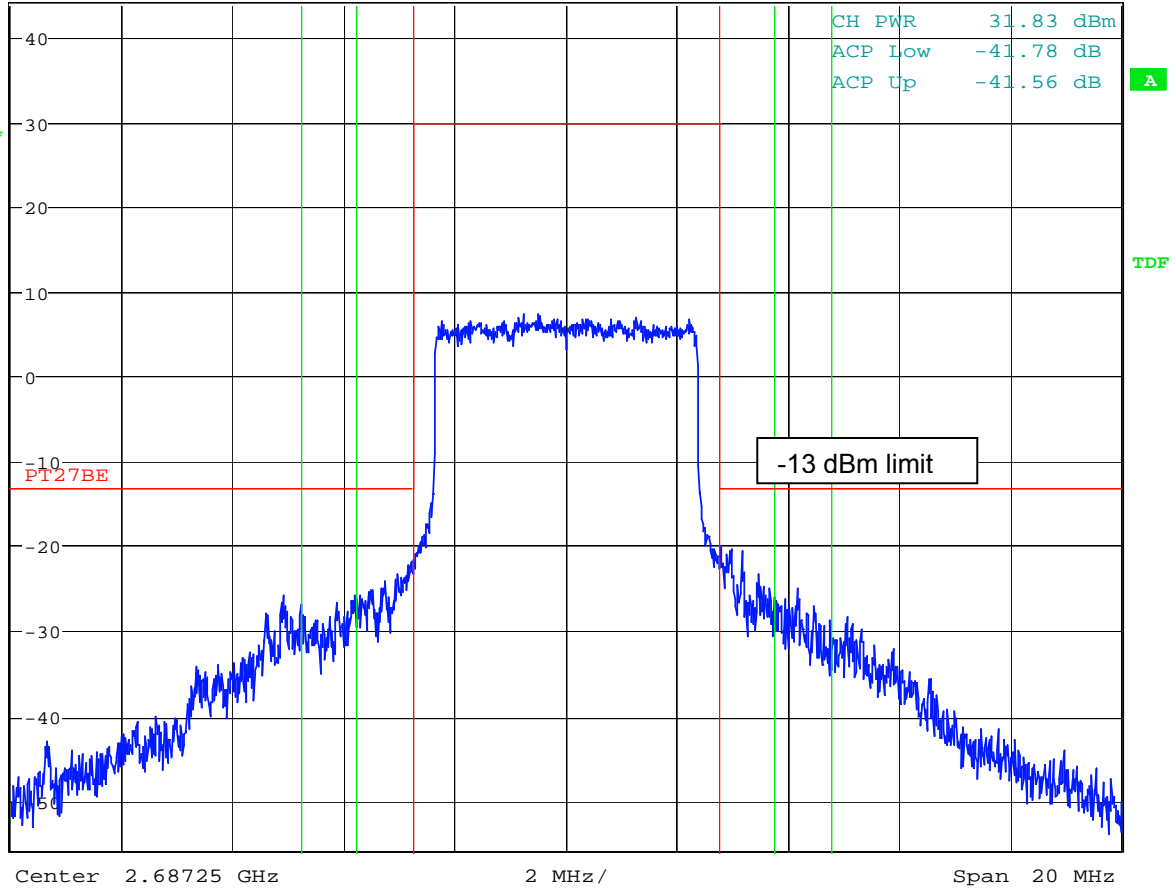

Date: 12.DEC.2007 09:24:28

This report and the information contained herein represent the results of testing test articles identified and selected by the client performed to specifications and/or procedures selected by the client. National Technical Systems (NTS) makes no representations, expressed or implied, that such testing is adequate (or inadequate) to demonstrate efficiency, performance, reliability, or any other characteristic of the articles being tested, or similar products. This report should not be relied upon as an endorsement or certification by NTS of the equipment tested, nor does it represent any statement whatsoever as to its merchantability or fitness of the test article, or similar products, for a particular purpose. This report shall not be reproduced except in full.

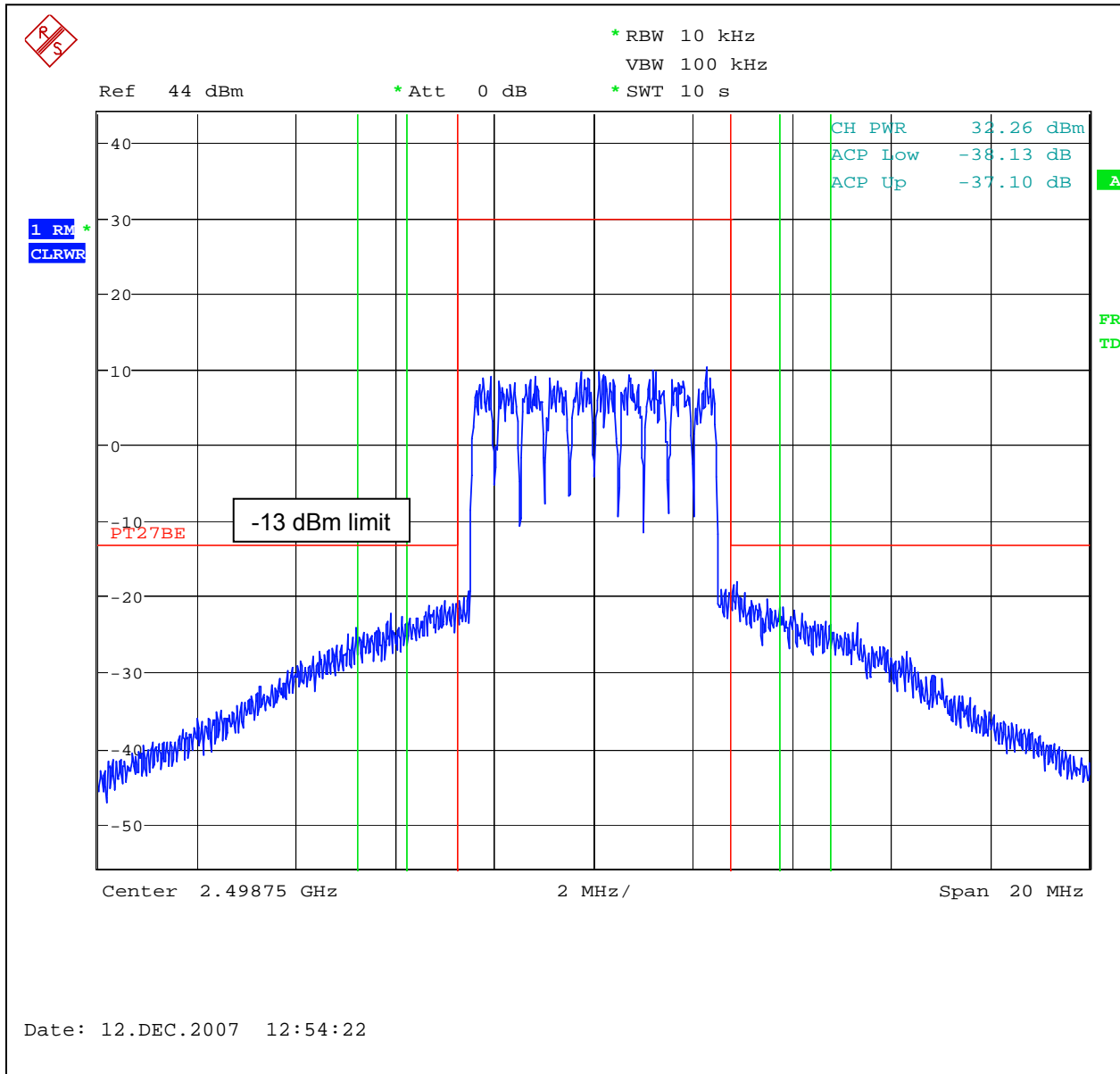

Figure 10 Lower Band Edge Spurious - 2496 MHz Band Edge (CDMA Mode)

This report and the information contained herein represent the results of testing test articles identified and selected by the client performed to specifications and/or procedures selected by the client. National Technical Systems (NTS) makes no representations, expressed or implied, that such testing is adequate (or inadequate) to demonstrate efficiency, performance, reliability, or any other characteristic of the articles being tested, or similar products. This report should not be relied upon as an endorsement or certification by NTS of the equipment tested, nor does it represent any statement whatsoever as to its merchantability or fitness of the test article, or similar products, for a particular purpose. This report shall not be reproduced except in full.

Figure 11 Spurious - 2597.50 MHz (CDMA Mode)



* RBW 10 kHz
 VBW 100 kHz
 * SWT 10 s

Ref 44 dBm

* Att 0 dB

1 RM *
 CLRWR

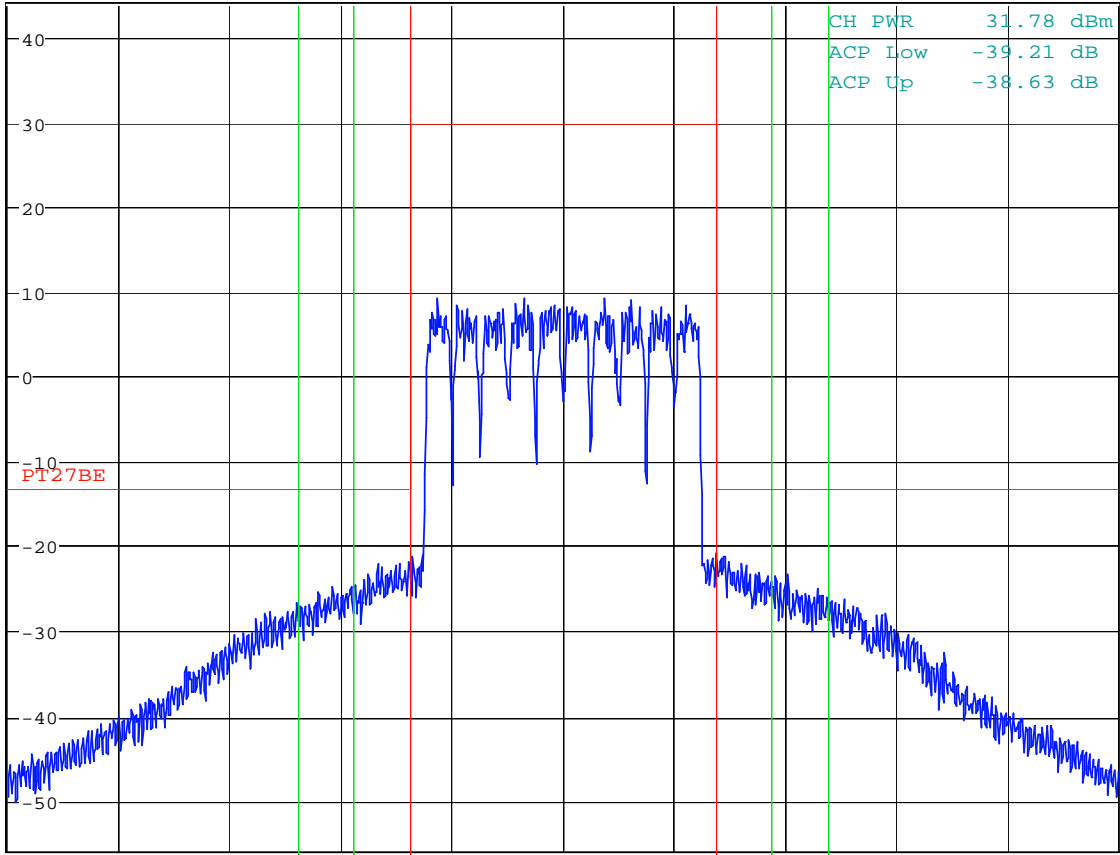

CH PWR 31.78 dBm
 ACP Low -39.21 dB
 ACP Up -38.63 dB

A
 TDF

Center 2.5975 GHz 2 MHz / Span 20 MHz

Date: 12.DEC.2007 15:41:32

This report and the information contained herein represent the results of testing test articles identified and selected by the client performed to specifications and/or procedures selected by the client. National Technical Systems (NTS) makes no representations, expressed or implied, that such testing is adequate (or inadequate) to demonstrate efficiency, performance, reliability, or any other characteristic of the articles being tested, or similar products. This report should not be relied upon as an endorsement or certification by NTS of the equipment tested, nor does it represent any statement whatsoever as to its merchantability or fitness of the test article, or similar products, for a particular purpose. This report shall not be reproduced except in full.

Figure 12 Upper Band Edge Spurious - 2690 MHz Band Edge (CDMA Mode)

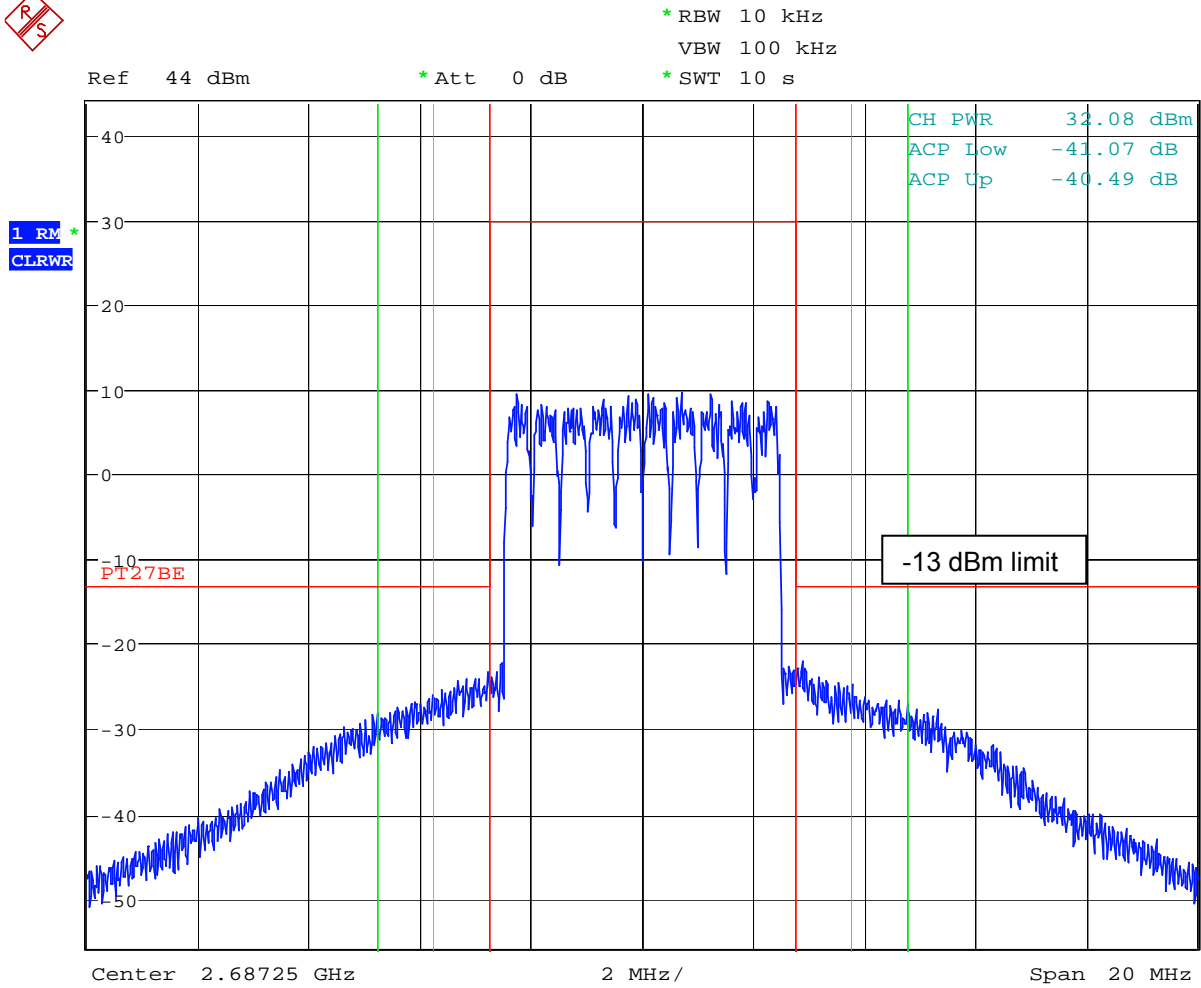

Date: 12.DEC.2007 15:51:21

This report and the information contained herein represent the results of testing test articles identified and selected by the client performed to specifications and/or procedures selected by the client. National Technical Systems (NTS) makes no representations, expressed or implied, that such testing is adequate (or inadequate) to demonstrate efficiency, performance, reliability, or any other characteristic of the articles being tested, or similar products. This report should not be relied upon as an endorsement or certification by NTS of the equipment tested, nor does it represent any statement whatsoever as to its merchantability or fitness of the test article, or similar products, for a particular purpose. This report shall not be reproduced except in full.

Figure 13 **Antenna Conducted Spurious - 2498.75 MHz (OFDMA Mode)**

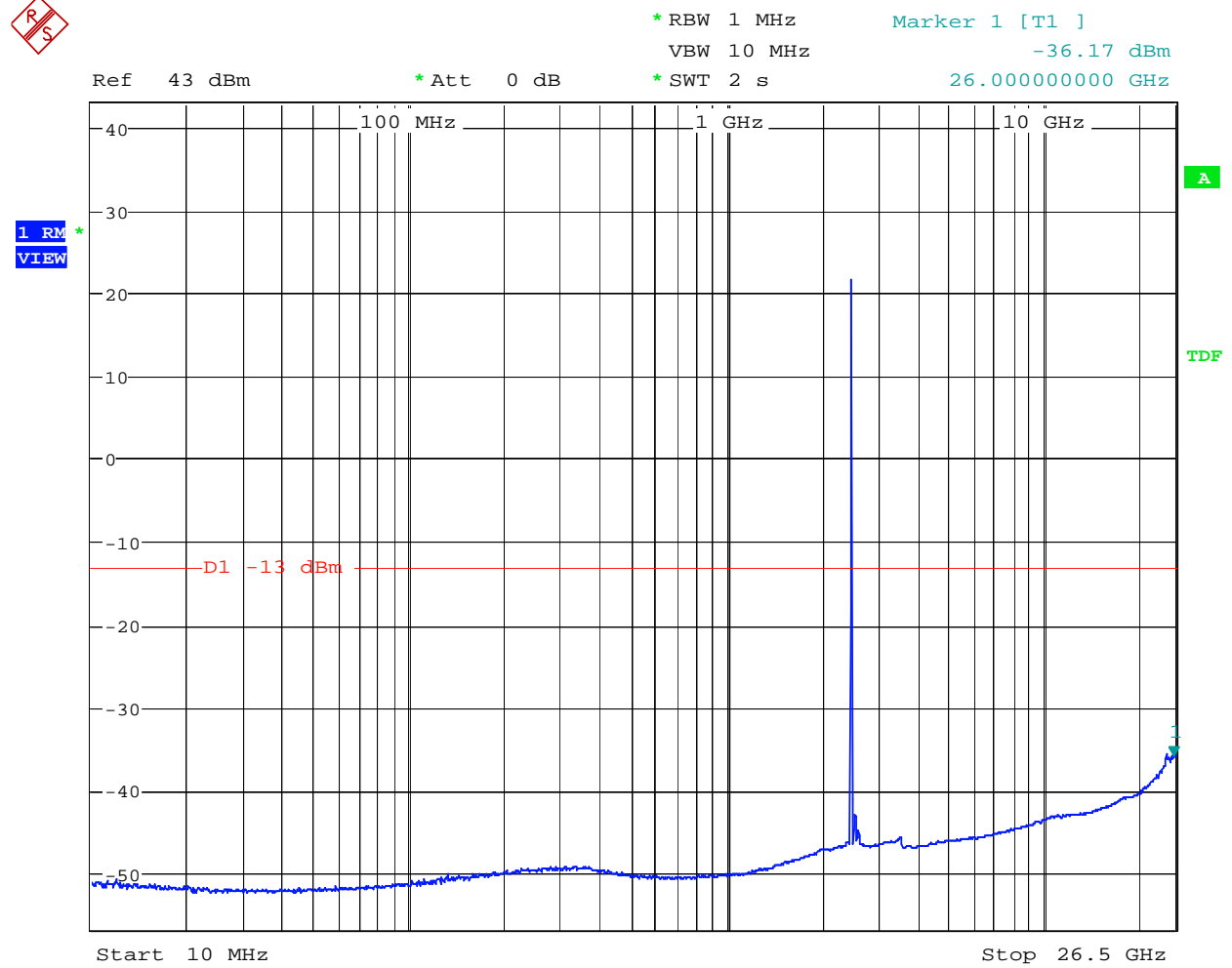

Date: 12.DEC.2007 09:13:51

This report and the information contained herein represent the results of testing test articles identified and selected by the client performed to specifications and/or procedures selected by the client. National Technical Systems (NTS) makes no representations, expressed or implied, that such testing is adequate (or inadequate) to demonstrate efficiency, performance, reliability, or any other characteristic of the articles being tested, or similar products. This report should not be relied upon as an endorsement or certification by NTS of the equipment tested, nor does it represent any statement whatsoever as to its merchantability or fitness of the test article, or similar products, for a particular purpose. This report shall not be reproduced except in full.

Figure 14 Antenna Conducted Spurious – 2597.5 MHz (OFDMA Mode)

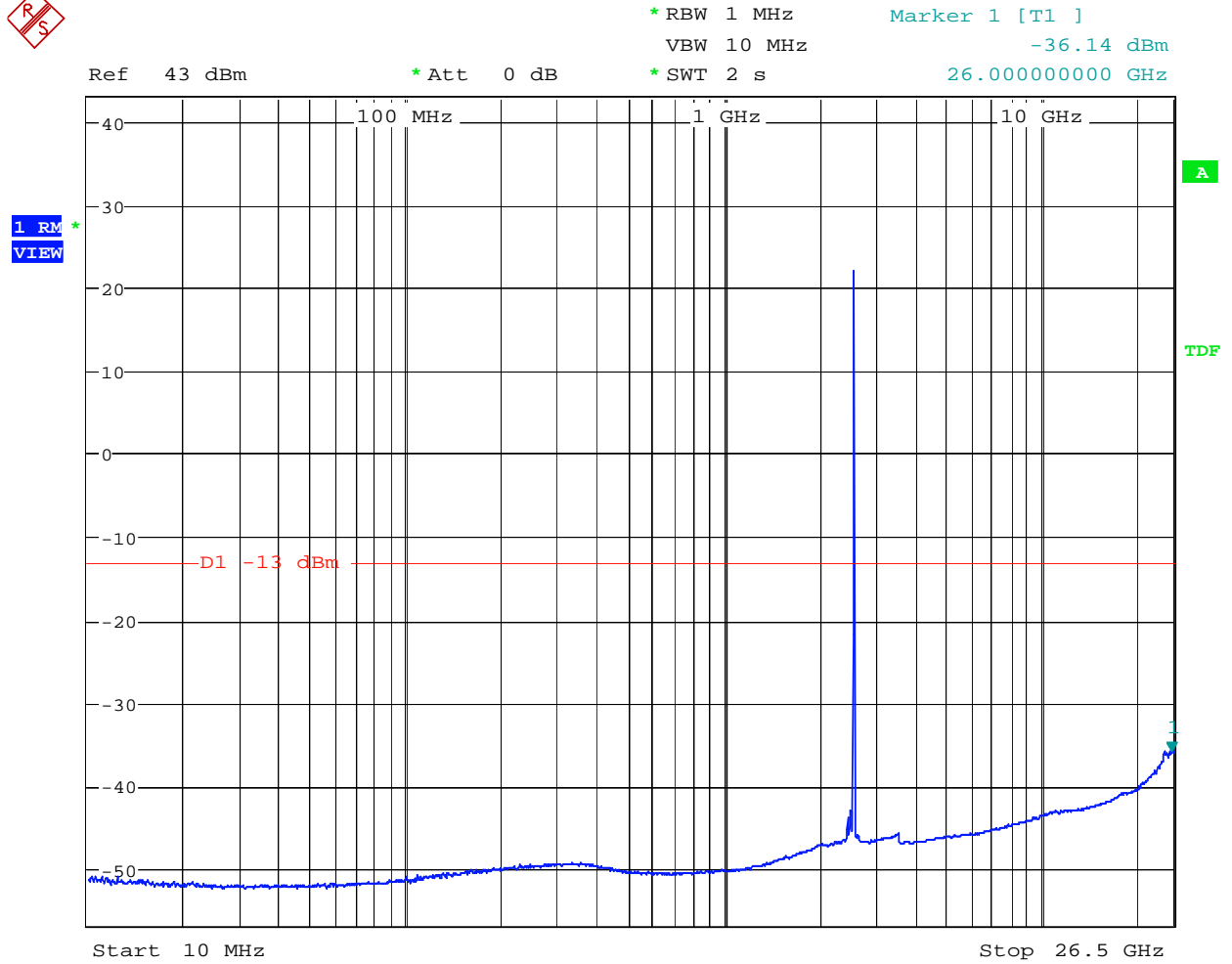

Date: 12.DEC.2007 09:20:40

This report and the information contained herein represent the results of testing test articles identified and selected by the client performed to specifications and/or procedures selected by the client. National Technical Systems (NTS) makes no representations, expressed or implied, that such testing is adequate (or inadequate) to demonstrate efficiency, performance, reliability, or any other characteristic of the articles being tested, or similar products. This report should not be relied upon as an endorsement or certification by NTS of the equipment tested, nor does it represent any statement whatsoever as to its merchantability or fitness of the test article, or similar products, for a particular purpose. This report shall not be reproduced except in full.

Figure 15 Antenna Conducted Spurious – 2687.25 MHz (OFDMA Mode)

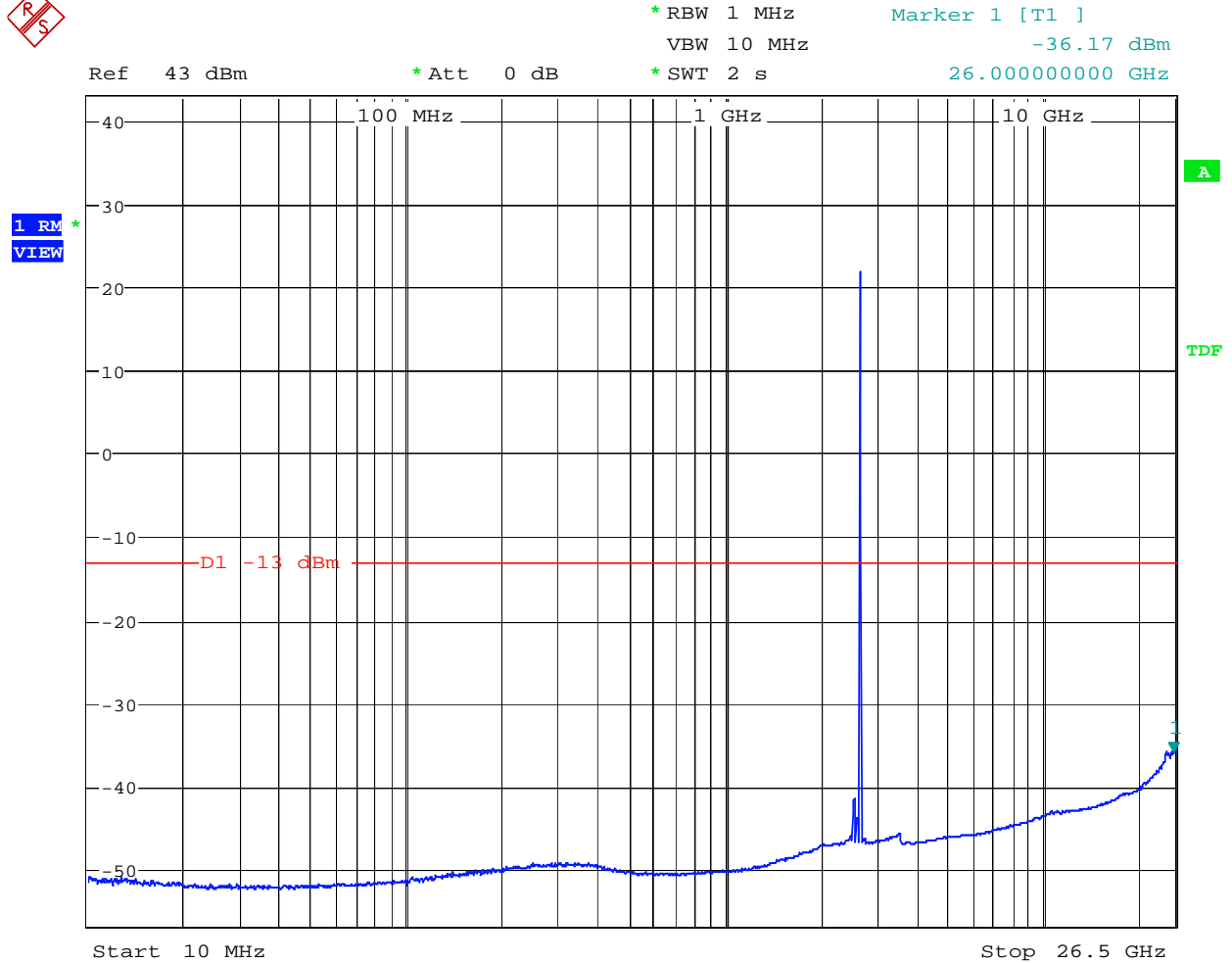

Date: 12.DEC.2007 09:26:55

This report and the information contained herein represent the results of testing test articles identified and selected by the client performed to specifications and/or procedures selected by the client. National Technical Systems (NTS) makes no representations, expressed or implied, that such testing is adequate (or inadequate) to demonstrate efficiency, performance, reliability, or any other characteristic of the articles being tested, or similar products. This report should not be relied upon as an endorsement or certification by NTS of the equipment tested, nor does it represent any statement whatsoever as to its merchantability or fitness of the test article, or similar products, for a particular purpose. This report shall not be reproduced except in full.

Figure 16 **Antenna Conducted Spurious - 2498.75 MHz (CDMA Mode)**

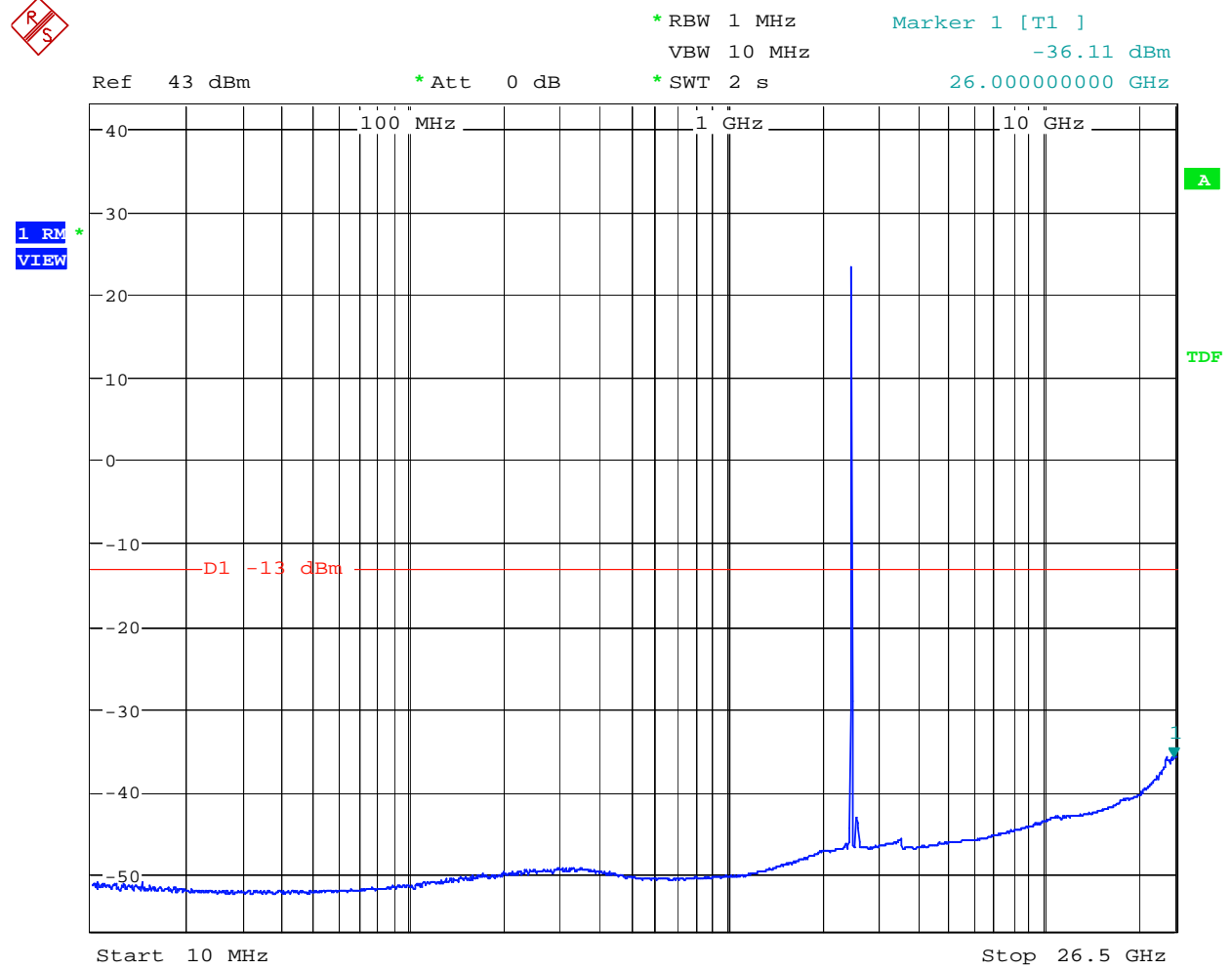

Date: 12.DEC.2007 15:35:24

This report and the information contained herein represent the results of testing test articles identified and selected by the client performed to specifications and/or procedures selected by the client. National Technical Systems (NTS) makes no representations, expressed or implied, that such testing is adequate (or inadequate) to demonstrate efficiency, performance, reliability, or any other characteristic of the articles being tested, or similar products. This report should not be relied upon as an endorsement or certification by NTS of the equipment tested, nor does it represent any statement whatsoever as to its merchantability or fitness of the test article, or similar products, for a particular purpose. This report shall not be reproduced except in full.

Figure 17 Antenna Conducted Spurious – 2597.5 MHz (CDMA Mode)

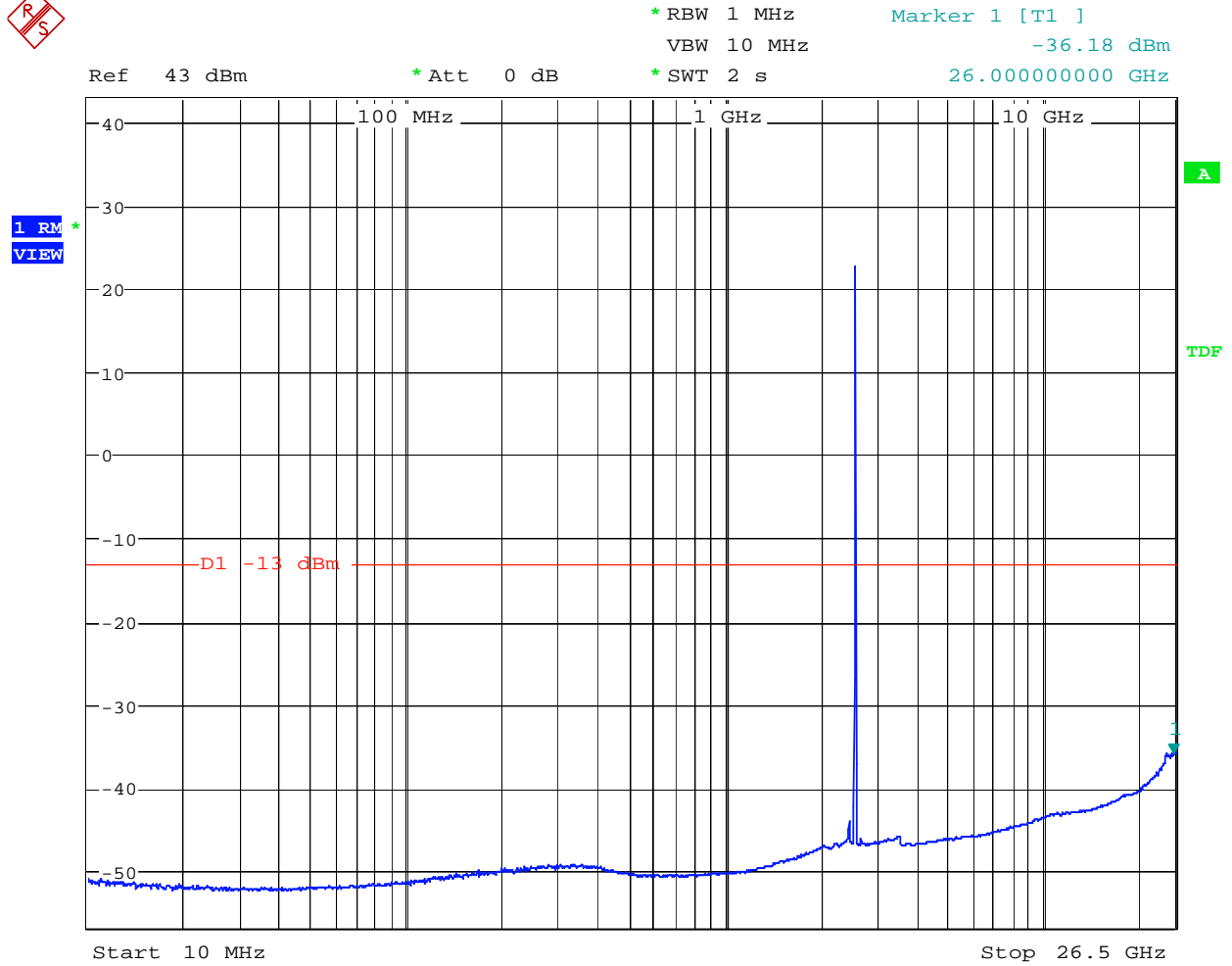

Date: 12.DEC.2007 15:37:27

This report and the information contained herein represent the results of testing test articles identified and selected by the client performed to specifications and/or procedures selected by the client. National Technical Systems (NTS) makes no representations, expressed or implied, that such testing is adequate (or inadequate) to demonstrate efficiency, performance, reliability, or any other characteristic of the articles being tested, or similar products. This report should not be relied upon as an endorsement or certification by NTS of the equipment tested, nor does it represent any statement whatsoever as to its merchantability or fitness of the test article, or similar products, for a particular purpose. This report shall not be reproduced except in full.

Figure 18 Antenna Conducted Spurious – 2687.25 MHz (CDMA Mode)



* RBW 1 MHz Marker 1 [T1]
VBW 10 MHz -36.11 dBm
* SWT 2 s 26.000000000 GHz

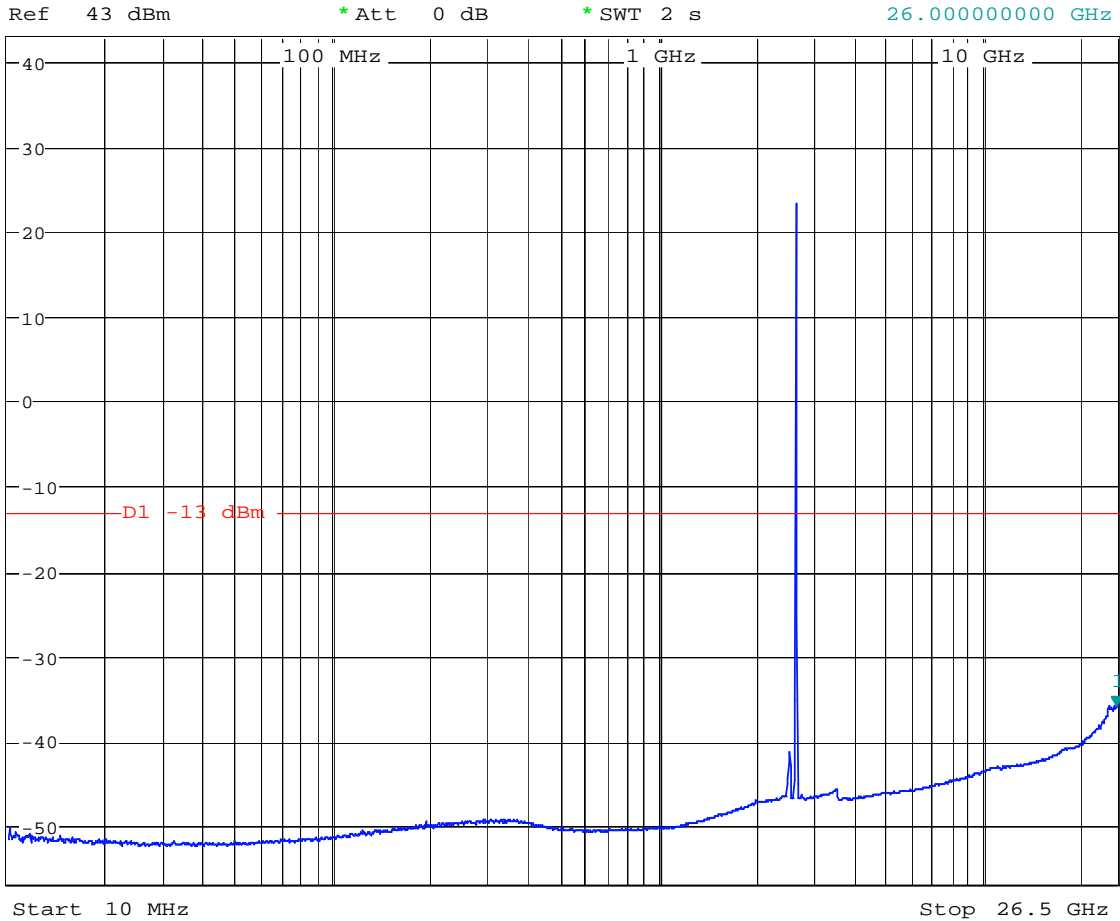

Date: 12.DEC.2007 15:54:16

D.9. Tested By

Test Date: 12 December, 2007
Tested by: Dwaine Hartman, Wireless Technician

This report and the information contained herein represent the results of testing test articles identified and selected by the client performed to specifications and/or procedures selected by the client. National Technical Systems (NTS) makes no representations, expressed or implied, that such testing is adequate (or inadequate) to demonstrate efficiency, performance, reliability, or any other characteristic of the articles being tested, or similar products. This report should not be relied upon as an endorsement or certification by NTS of the equipment tested, nor does it represent any statement whatsoever as to its merchantability or fitness of the test article, or similar products, for a particular purpose. This report shall not be reproduced except in full.

APPENDIX E: 2.1053 FIELD STRENGTH OF SPURIOUS RADIATION

E.1. Base Standard & Test Basis

Base Standard	FCC 2.1053
Test Basis	FCC 2.1053 Field Strength of Spurious Radiation
Test Method	TIA 603-C, 2004 Substitution Antenna Method

E.2. Limits

27.53(l)

(1) Prior to the transition, and thereafter, solely within the MBS, for analog operations with an EIRP in excess of -9 dBW, the signal shall be attenuated at the channel edges by at least 38 dB relative to the peak visual carrier, then linearly sloping from that level to at least 60 dB of attenuation at 1 MHz below the lower band edge and 0.5 MHz above the upper band edge, and attenuated at least 60 dB at all other frequencies.

(2) **For fixed and temporary fixed digital stations, the attenuation shall be not less than $43 + 10 \log(P)$ dB**, unless a documented interference complaint is received from an adjacent channel licensee. Provided that the complaint cannot be mutually resolved between the parties, both licensees of existing and new systems shall reduce their out-of-band emissions by at least $67 + 10 \log(P)$ dB measured at 3 MHz from their channel's edges for distances between stations exceeding 1.5 km. For stations separated by less than 1.5 km, the new licensee shall reduce attenuation at least $67 + 10 \log(P) - 20 \log(D\text{km}/1.5)$, or when colocated, limit the undesired signal level at the affected licensee's base station receiver(s) at the colocation site to no more than -107 dBm. Mobile Service Satellite licensees operating on frequencies below 2495 MHz may also submit a documented interference complaint against BRS licensees operating on channel BRS1 on the same terms and conditions as adjacent channel BRS or EBS licensees.

(3) Prior to transition and thereafter solely within the MBS, and notwithstanding paragraph (l)(2) of this section, the maximum out-of-band power of a digital transmitter operating on a single 6 MHz channel with an EIRP in excess of -9 dBW employing digital modulation for the primary purpose of transmitting video programming shall be attenuated at the 6 MHz channel edges at least 25 dB relative to the licensed average 6 MHz channel power level, then attenuated along a linear slope to at least 40 dB at 250 kHz beyond the nearest channel edge, then attenuated along a linear slope from that level to at least 60 dB at 3 MHz above the upper and below the lower licensed channel edges, and attenuated at least 60 dB at all other frequencies.

(4) For mobile digital stations, the attenuation factor shall be not less than $43 + 10 \log(P)$ dB at the channel edge and $55 + 10 \log(P)$ dB at 5.5 MHz from the channel edges. Mobile Service Satellite licensees operating on frequencies below 2495 MHz may also submit a documented interference complaint against BRS licensees operating on channel BRS1 on the same terms and conditions as adjacent channel BRS or EBS licensees.

(5) Notwithstanding the provisions of paragraphs (l)(2) and (l)(4) of this section, prior to transition, a licensee may continue to operate facilities deployed as of January 10, 2005 provided that such facilities operate in compliance with the emission mask applicable to those services prior to January 10, 2005.

(6) Measurement procedure. Compliance with these rules is based on the use of measurement instrumentation employing a resolution bandwidth of 1 MHz or greater. However, in the 1 MHz bands immediately outside and adjacent to the frequency block a resolution bandwidth of at least one percent of the emission bandwidth of the fundamental emission of the transmitter may be employed. A narrower resolution bandwidth is permitted in all cases to improve measurement accuracy provided the measured power is integrated over the full required measurement

This report and the information contained herein represent the results of testing test articles identified and selected by the client performed to specifications and/or procedures selected by the client. National Technical Systems (NTS) makes no representations, expressed or implied, that such testing is adequate (or inadequate) to demonstrate efficiency, performance, reliability, or any other characteristic of the articles being tested, or similar products. This report should not be relied upon as an endorsement or certification by NTS of the equipment tested, nor does it represent any statement whatsoever as to its merchantability or fitness of the test article, or similar products, for a particular purpose. This report shall not be reproduced except in full.

bandwidth (i.e. 1 MHz or 1 percent of emission bandwidth, as specified). The emission bandwidth is defined as the width of the signal between two points, one below the carrier center frequency and one above the carrier center frequency, outside of which all emissions are attenuated at least 26 dB below the transmitter power. With respect to television operations, measurements must be made of the separate visual and aural operating powers at sufficiently frequent intervals to ensure compliance with the rules.

E.3. Test Results

Compliant. The worst-case spurious emission level was -23.8 dBm at 18,182.5 MHz. This level is 10.8 dB below the specification limit of -13 dBm. The spectrum was searched up to 27 GHz with the device operating on four channels.

E.4. Deviations from Normal Operating Mode During Test

None.

E.5. Sample Calculation

Final measured value (dBm) = Substitution level (dBm) + Antenna Gain (dBd)

Minimum attenuation limit (dB) = 43 + 10 log(P) where P = Peak power of the carrier in watts.

Min. Atten. Limit dB) = 43 + 10 * log(2 watts)
= 46 dB

33 dBm – 46 dB = -13 dBm

This report and the information contained herein represent the results of testing test articles identified and selected by the client performed to specifications and/or procedures selected by the client. National Technical Systems (NTS) makes no representations, expressed or implied, that such testing is adequate (or inadequate) to demonstrate efficiency, performance, reliability, or any other characteristic of the articles being tested, or similar products. This report should not be relied upon as an endorsement or certification by NTS of the equipment tested, nor does it represent any statement whatsoever as to its merchantability or fitness of the test article, or similar products, for a particular purpose. This report shall not be reproduced except in full.

E.6. Test Diagram

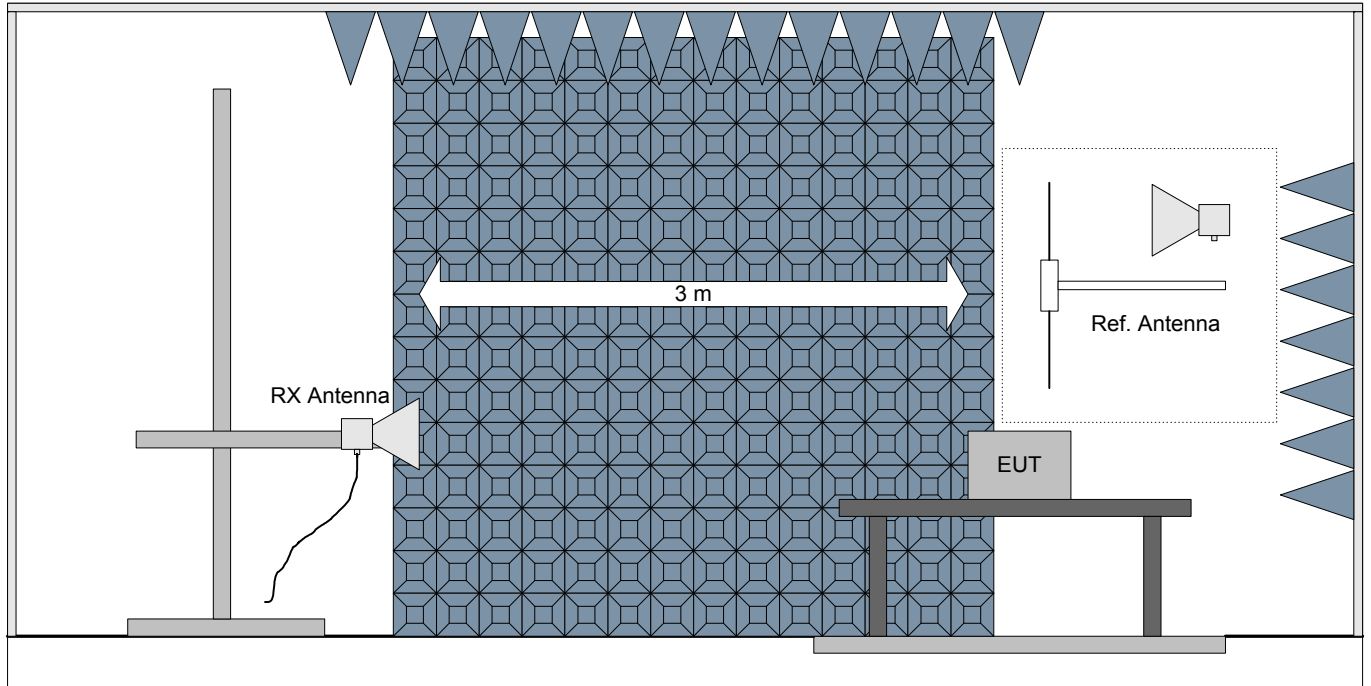

Note: The EUT is set to transmit a signal at maximum rf output power into a coaxial load for this testing.

This report and the information contained herein represent the results of testing test articles identified and selected by the client performed to specifications and/or procedures selected by the client. National Technical Systems (NTS) makes no representations, expressed or implied, that such testing is adequate (or inadequate) to demonstrate efficiency, performance, reliability, or any other characteristic of the articles being tested, or similar products. This report should not be relied upon as an endorsement or certification by NTS of the equipment tested, nor does it represent any statement whatsoever as to its merchantability or fitness of the test article, or similar products, for a particular purpose. This report shall not be reproduced except in full.

E.7. Test Data

	Project No:	Navini Networks W7442											
	Model:	2.5/2.6 GHz MX8 BTS											
	Comments:	Transmit at full rf output power, CDMA Mode											
	Date:	12/14/2007											
Distance:	3 m	Standard:	CFR 47, Part 2.1053					RBW: (unless noted)	< 1 GHz = 120 kHz > 1 GHz = 1 MHz		VBW: (unless noted)	Peak = RBW	Avg. = 10Hz
Antenna	Polarization	Frequency	Measured	Substitution Level	Substitution Antenna Gain	Final Measured Value		Peak Carrier Power		Minimum Attenuation Limit	Margin		
	(V/H)	(MHz)	(dBm)	(dBm)	(dBi)	(dBm)	(watts)	(dBm)	(watts)	(dBc)	(dB)		
Ref. E1019	V	4997.5	-131.4	-58.41	8.73	-49.7	1.08E-08	32.2	1.7	45.2	36.7		
Ref. E1019	H	4997.5	-133.2	-60.21	8.73	-51.5	7.11E-09	32.2	1.7	45.2	38.5		
Ref. E1019	V	7496.25	-124.8	-53.82	9.77	-44.1	3.94E-08	32.2	1.7	45.2	31.1		
Ref. E1019	H	7496.25	-124.7	-53.72	9.77	-44.0	4.03E-08	32.2	1.7	45.2	31.0		
Ref. E1019	V	9985	-118.5	-49.20	9.85	-39.4	1.16E-07	32.2	1.7	45.2	26.4		
Ref. E1019	H	9985	-118.5	-49.20	9.85	-39.4	1.16E-07	32.2	1.7	45.2	26.4		
Ref. E1019	V	12493.75	-115.1	-47.55	10.55	-37.0	2.00E-07	32.2	1.7	45.2	24.0		
Ref. E1019	H	12493.75	-115.0	-47.45	10.55	-36.9	2.04E-07	32.2	1.7	45.2	23.9		
Ref. E1019	V	14982.5	-113.3	-50.71	9.05	-41.7	6.82E-08	32.2	1.7	45.2	28.7		
Ref. E1019	H	14982.5	-113.2	-50.61	9.05	-41.6	6.98E-08	32.2	1.7	45.2	28.6		
Ref. E1019	V	17491.25	-113.0	-48.80	11.87	-36.9	2.03E-07	32.2	1.7	45.2	23.9		
Ref. E1019	H	17491.25	-113.0	-48.80	11.87	-36.9	2.03E-07	32.2	1.7	45.2	23.9		
Notes:	(1) A positive margin indicates a passing result												
	(2) Spurious emissions were measured with average detection and compared to the maximum average fundamental power of 1.7 watts.												
	(3) The minimum threshold of sensitivity was sufficient to detect signals within 10 dB of the -40 dBm limit over the frequency range 30 MHz - 26 GHz.												

	Project No:	Navini Networks W7442											
	Model:	2.5/2.6 GHz MX8 BTS											
	Comments:	Transmit at full rf output power, OFDMA Mode											
	Date:	12/14/2007											
Distance:	3 m	Standard:	CFR 47, Part 2.1053					RBW: (unless noted)	< 1 GHz = 120 kHz > 1 GHz = 1 MHz		VBW: (unless noted)	Peak = RBW	Avg. = 10Hz
Antenna	Polarization	Frequency	Measured	Substitution Level	Substitution Antenna Gain	Final Measured Value		Peak Carrier Power		Minimum Attenuation Limit	Margin		
	(V/H)	(MHz)	(dBm)	(dBm)	(dBi)	(dBm)	(watts)	(dBm)	(watts)	(dBc)	(dB)		
Ref. E1019	V	4997.5	-131.4	-58.41	8.73	-49.7	1.08E-08	32.2	1.7	45.2	36.7		
Ref. E1019	H	4997.5	-133.2	-60.21	8.73	-51.5	7.11E-09	32.2	1.7	45.2	38.5		
Ref. E1019	V	7496.25	-124.8	-53.82	9.77	-44.1	3.94E-08	32.2	1.7	45.2	31.1		
Ref. E1019	H	7496.25	-124.7	-53.72	9.77	-44.0	4.03E-08	32.2	1.7	45.2	31.0		
Ref. E1019	V	9985	-118.5	-49.20	9.85	-39.4	1.16E-07	32.2	1.7	45.2	26.4		
Ref. E1019	H	9985	-118.5	-49.20	9.85	-39.4	1.16E-07	32.2	1.7	45.2	26.4		
Ref. E1019	V	12493.75	-115.1	-47.55	10.55	-37.0	2.00E-07	32.2	1.7	45.2	24.0		
Ref. E1019	H	12493.75	-115.0	-47.45	10.55	-36.9	2.04E-07	32.2	1.7	45.2	23.9		
Ref. E1019	V	14982.5	-113.3	-50.71	9.05	-41.7	6.82E-08	32.2	1.7	45.2	28.7		
Ref. E1019	H	14982.5	-113.2	-50.61	9.05	-41.6	6.98E-08	32.2	1.7	45.2	28.6		
Ref. E1019	V	17491.25	-113.0	-48.80	11.87	-36.9	2.03E-07	32.2	1.7	45.2	23.9		
Ref. E1019	H	17491.25	-113.0	-48.80	11.87	-36.9	2.03E-07	32.2	1.7	45.2	23.9		
Notes:	(1) A positive margin indicates a passing result												
	(2) Spurious emissions were measured with average detection and compared to the maximum average fundamental power of 1.7 watts.												
	(3) The minimum threshold of sensitivity was sufficient to detect signals within 10 dB of the -40 dBm limit over the frequency range 30 MHz - 26 GHz.												

Note: Emissions were checked at 4 frequencies across the band. The data presented above was the worst-case result which was with maximum rf power output at 2597.5 MHz. The spectrum was searched from 30 MHz up to 26 GHz.

This report and the information contained herein represent the results of testing test articles identified and selected by the client performed to specifications and/or procedures selected by the client. National Technical Systems (NTS) makes no representations, expressed or implied, that such testing is adequate (or inadequate) to demonstrate efficiency, performance, reliability, or any other characteristic of the articles being tested, or similar products. This report should not be relied upon as an endorsement or certification by NTS of the equipment tested, nor does it represent any statement whatsoever as to its merchantability or fitness of the test article, or similar products, for a particular purpose. This report shall not be reproduced except in full.

E.8. Test Photo

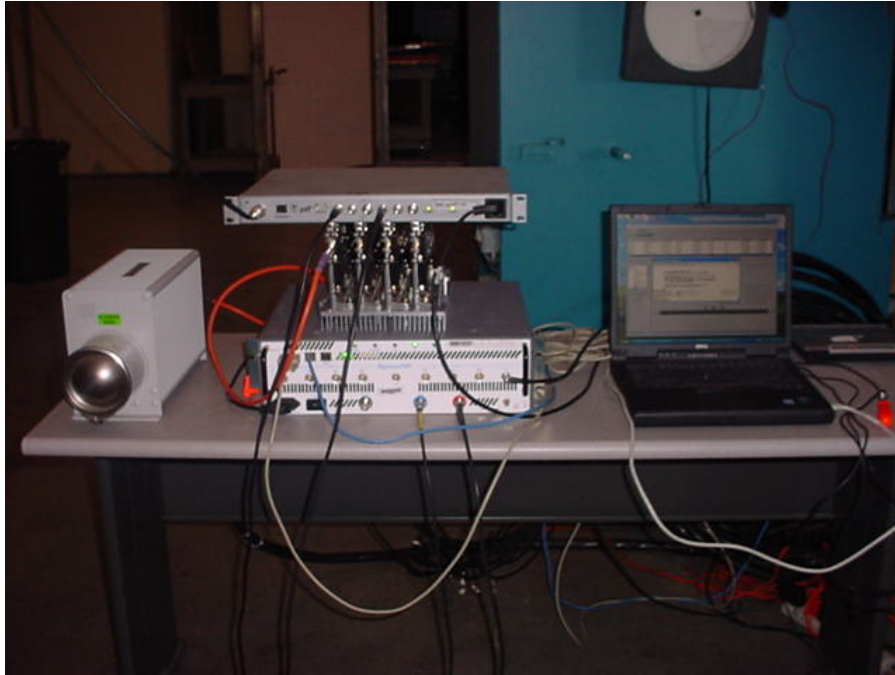

E.9. Tested By

Test Date: 14 December, 2007

Tested by: Dwaine Hartman, Wireless Technician

This report and the information contained herein represent the results of testing test articles identified and selected by the client performed to specifications and/or procedures selected by the client. National Technical Systems (NTS) makes no representations, expressed or implied, that such testing is adequate (or inadequate) to demonstrate efficiency, performance, reliability, or any other characteristic of the articles being tested, or similar products. This report should not be relied upon as an endorsement or certification by NTS of the equipment tested, nor does it represent any statement whatsoever as to its merchantability or fitness of the test article, or similar products, for a particular purpose. This report shall not be reproduced except in full.

NTS Plano, 1701 E. Plano Pkwy., Plano, TX 75074 Tel: (972) 509-2566, Fax: (972) 509-0073

APPENDIX F: 2.1055 FREQUENCY STABILITY

F.1. Base Standard & Test Basis

Base Standard	FCC 2.1055
Test Method	TIA 603-C, 2004

Specifications

27.54 Frequency Stability

The frequency stability shall be sufficient to ensure that the fundamental emissions stay within the authorized bands of operation.

F.2. Deviations

Deviation Number	Time & Date	Description and Justification of Deviation	Deviation Reference			Approval
			Base Standard	Test Basis	NTS Procedure	
none						

F.3. Test Results

Compliant. The device continues to stay wholly within the assigned channel at environmental extremes. **The device will cease transmitting if the the operation temperature is out of range (0 to 50degC).**

F.4. Observations

It was verified that the transmitter ceases to operate below +0 degrees Celsius and above +50 degrees Celsius.

F.5. Deviations from Normal Operating Mode During Test

None.

F.6. Sample Calculation

N/A

F.7. Test Data

See plots on following pages.

This report and the information contained herein represent the results of testing test articles identified and selected by the client performed to specifications and/or procedures selected by the client. National Technical Systems (NTS) makes no representations, expressed or implied, that such testing is adequate (or inadequate) to demonstrate efficiency, performance, reliability, or any other characteristic of the articles being tested, or similar products. This report should not be relied upon as an endorsement or certification by NTS of the equipment tested, nor does it represent any statement whatsoever as to its merchantability or fitness of the test article, or similar products, for a particular purpose. This report shall not be reproduced except in full.

F.8. Test Diagram

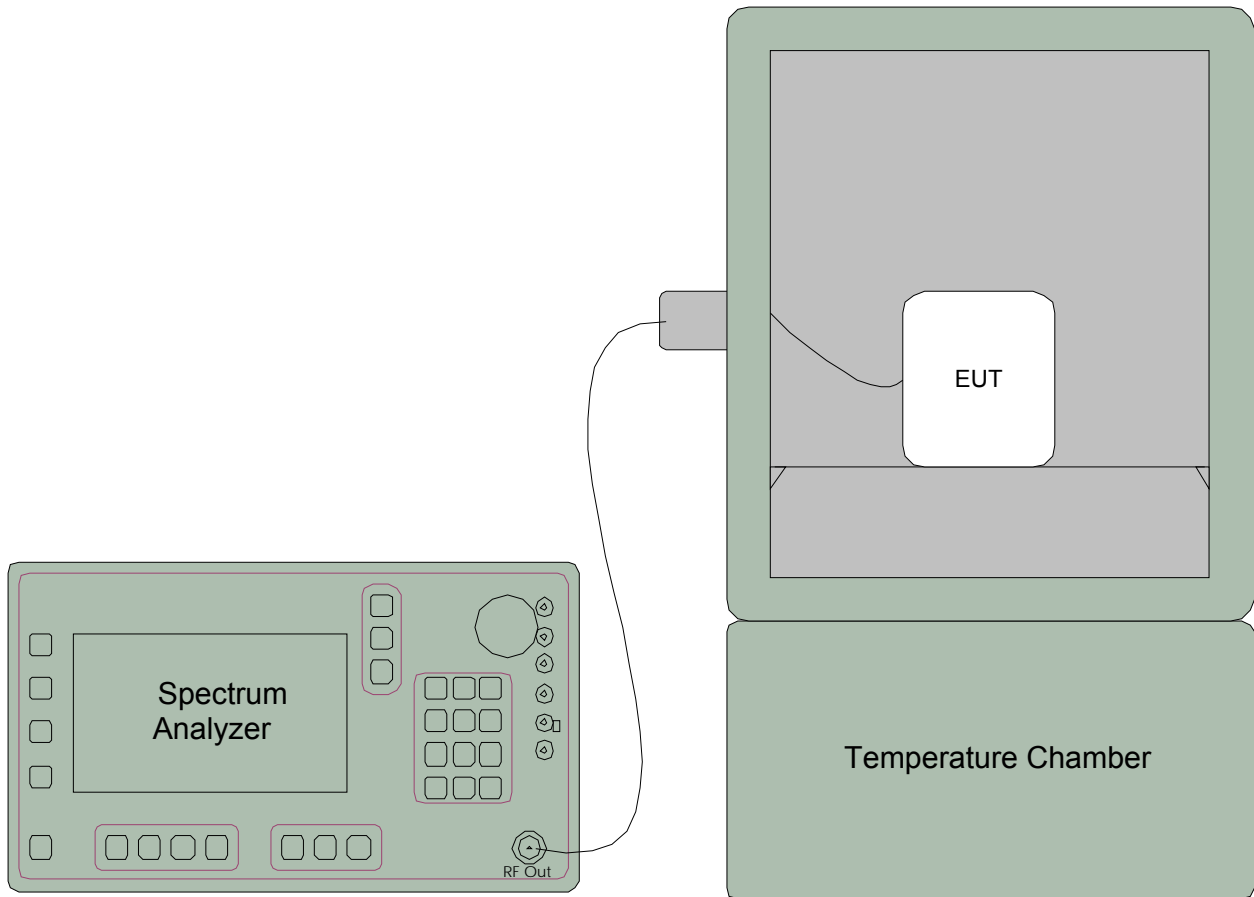

F.9. Tested By

Test Date: 12 December, 2007

Tested by: Dwaine Hartman, Wireless Technician

This report and the information contained herein represent the results of testing test articles identified and selected by the client performed to specifications and/or procedures selected by the client. National Technical Systems (NTS) makes no representations, expressed or implied, that such testing is adequate (or inadequate) to demonstrate efficiency, performance, reliability, or any other characteristic of the articles being tested, or similar products. This report should not be relied upon as an endorsement or certification by NTS of the equipment tested, nor does it represent any statement whatsoever as to its merchantability or fitness of the test article, or similar products, for a particular purpose. This report shall not be reproduced except in full.

**Figure 19 LOW VOLTAGE(102 VAC)/AMBIENT TEMPERATURE (+20 deg. C)
2498.75 MHz (OFDMA Mode)**



* RBW 10 kHz
* VBW 100 kHz
* SWT 10 s

Ref 44 dBm

* Att 0 dB

1 RM *
CLRWR

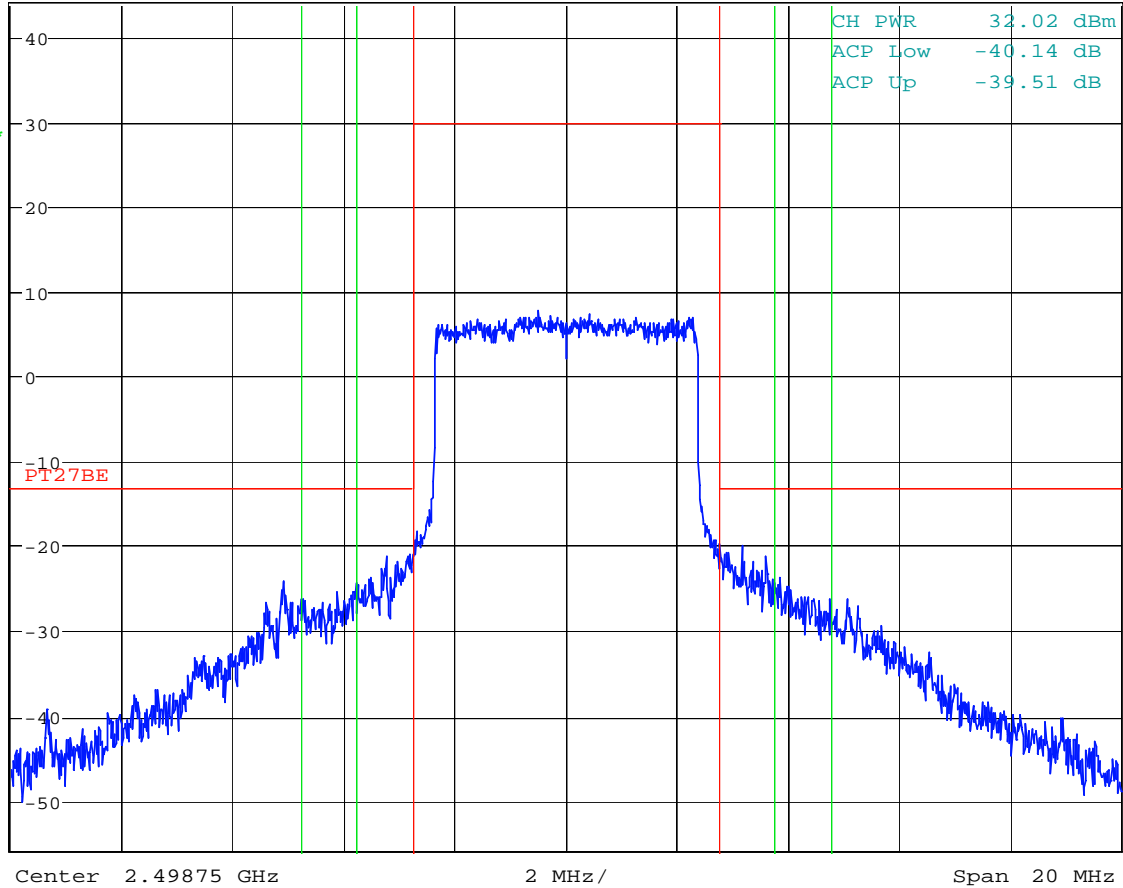

A
TDF

Date: 12.DEC.2007 09:35:34

This report and the information contained herein represent the results of testing test articles identified and selected by the client performed to specifications and/or procedures selected by the client. National Technical Systems (NTS) makes no representations, expressed or implied, that such testing is adequate (or inadequate) to demonstrate efficiency, performance, reliability, or any other characteristic of the articles being tested, or similar products. This report should not be relied upon as an endorsement or certification by NTS of the equipment tested, nor does it represent any statement whatsoever as to its merchantability or fitness of the test article, or similar products, for a particular purpose. This report shall not be reproduced except in full.

**Figure 20 HIGH VOLTAGE(138 VAC)/AMBIENT TEMPERATURE (+20 deg. C)
2498.75 MHz (OFDMA Mode)**



* RBW 10 kHz
* VBW 100 kHz
* SWT 10 s

Ref 44 dBm

* Att 0 dB

1 RM *
CLRWR

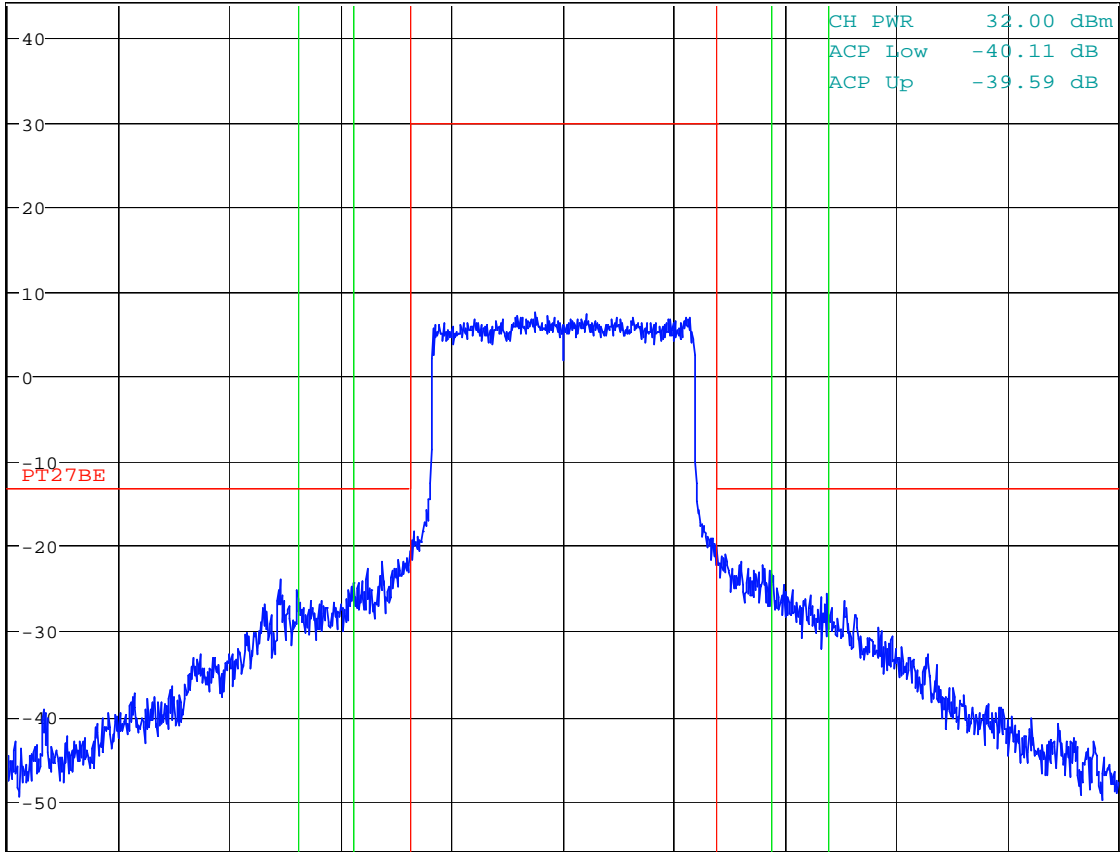

Center 2.49875 GHz

2 MHz /

Span 20 MHz

Date: 12.DEC.2007 09:36:54

This report and the information contained herein represent the results of testing test articles identified and selected by the client performed to specifications and/or procedures selected by the client. National Technical Systems (NTS) makes no representations, expressed or implied, that such testing is adequate (or inadequate) to demonstrate efficiency, performance, reliability, or any other characteristic of the articles being tested, or similar products. This report should not be relied upon as an endorsement or certification by NTS of the equipment tested, nor does it represent any statement whatsoever as to its merchantability or fitness of the test article, or similar products, for a particular purpose. This report shall not be reproduced except in full.

Figure 21 0 ° C, Nominal Voltage (120 VAC) 2498.75 MHz (OFDMA Mode)



* RBW 10 kHz
VBW 100 kHz
* SWT 10 s

Ref 44 dBm

* Att 0 dB

1 RM *
CLRWR

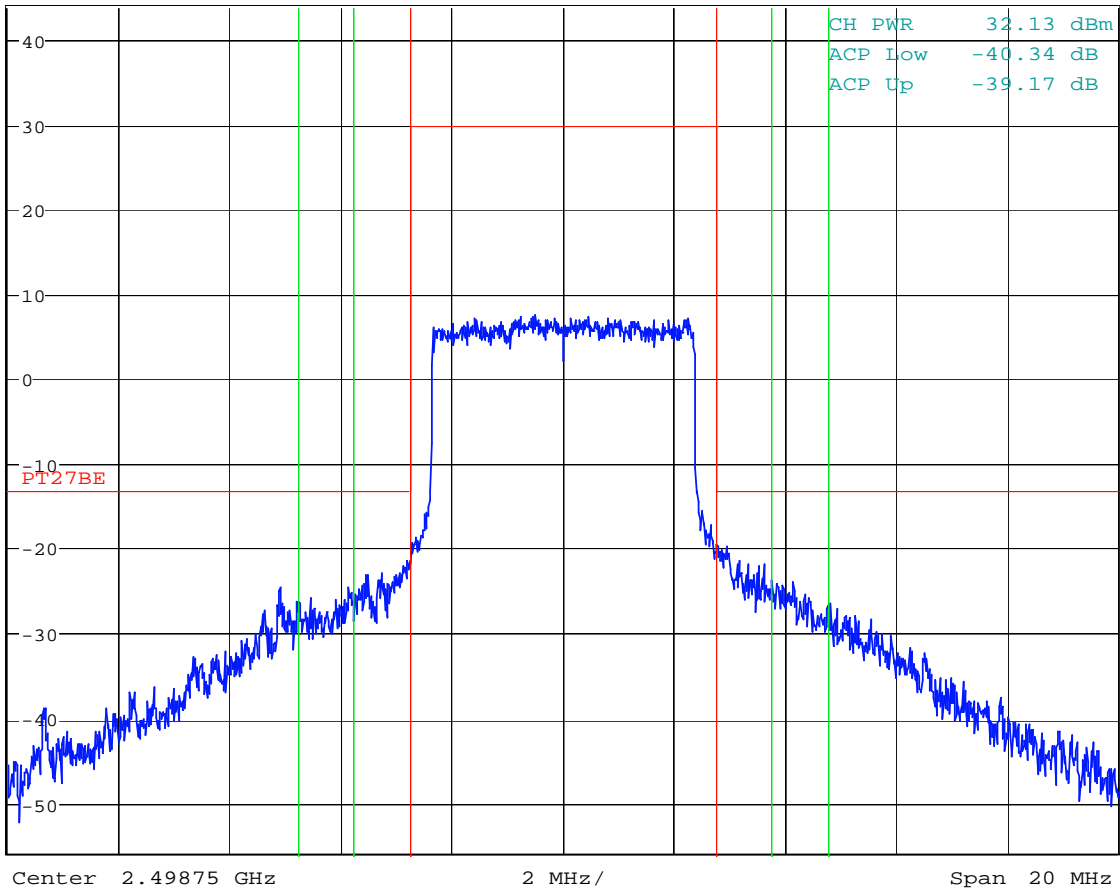

Date: 12.DEC.2007 10:59:40

This report and the information contained herein represent the results of testing test articles identified and selected by the client performed to specifications and/or procedures selected by the client. National Technical Systems (NTS) makes no representations, expressed or implied, that such testing is adequate (or inadequate) to demonstrate efficiency, performance, reliability, or any other characteristic of the articles being tested, or similar products. This report should not be relied upon as an endorsement or certification by NTS of the equipment tested, nor does it represent any statement whatsoever as to its merchantability or fitness of the test article, or similar products, for a particular purpose. This report shall not be reproduced except in full.

Figure 22 +10 ° C, Nominal Voltage (120 VAC) 2498.75 MHz (OFDMA Mode)



* RBW 10 kHz
VBW 100 kHz
* SWT 10 s

Ref 44 dBm

* Att 0 dB

1 RM *
CLRWR

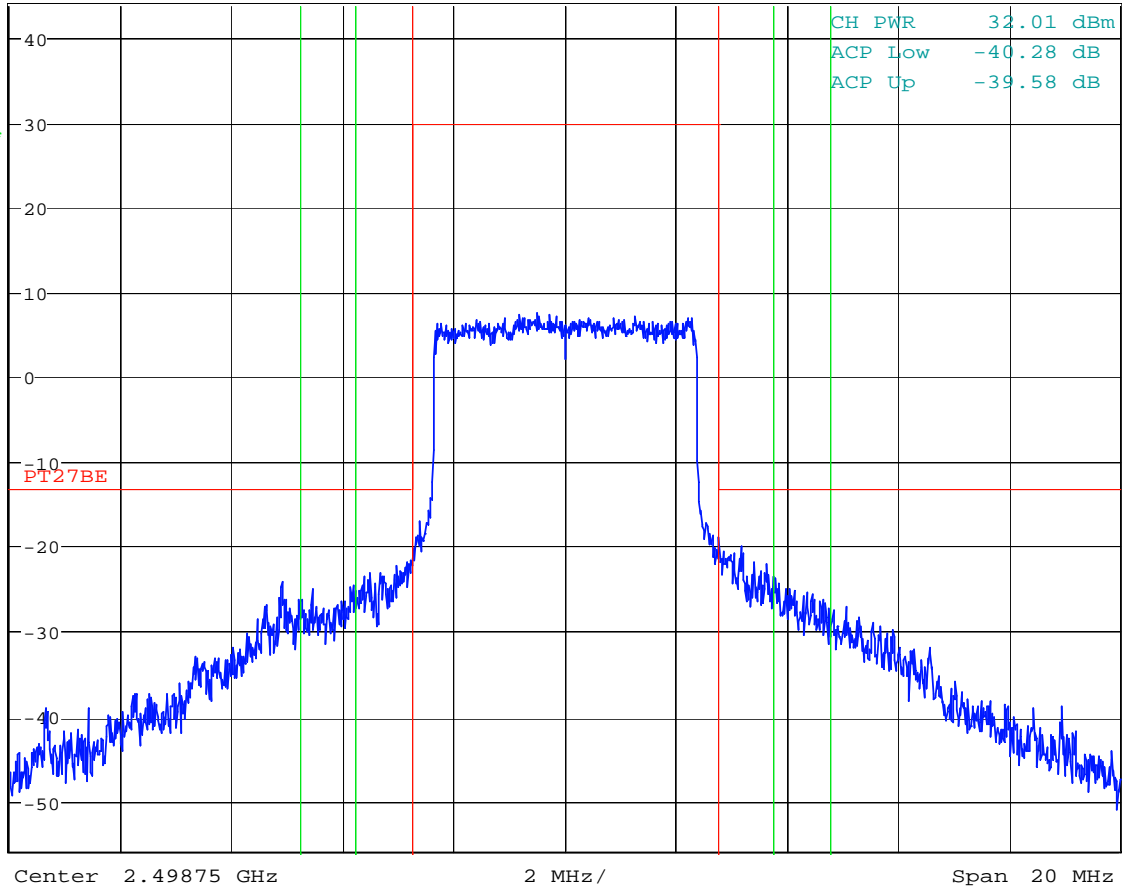

Date: 12.DEC.2007 10:43:21

This report and the information contained herein represent the results of testing test articles identified and selected by the client performed to specifications and/or procedures selected by the client. National Technical Systems (NTS) makes no representations, expressed or implied, that such testing is adequate (or inadequate) to demonstrate efficiency, performance, reliability, or any other characteristic of the articles being tested, or similar products. This report should not be relied upon as an endorsement or certification by NTS of the equipment tested, nor does it represent any statement whatsoever as to its merchantability or fitness of the test article, or similar products, for a particular purpose. This report shall not be reproduced except in full.

Figure 23 +30 ° C, Nominal Voltage (120 VAC) 2498.75 MHz (OFDMA Mode)



* RBW 10 kHz
 * VBW 100 kHz
 * SWT 10 s

Ref 44 dBm * Att 0 dB

1 RM *
 CLRWR

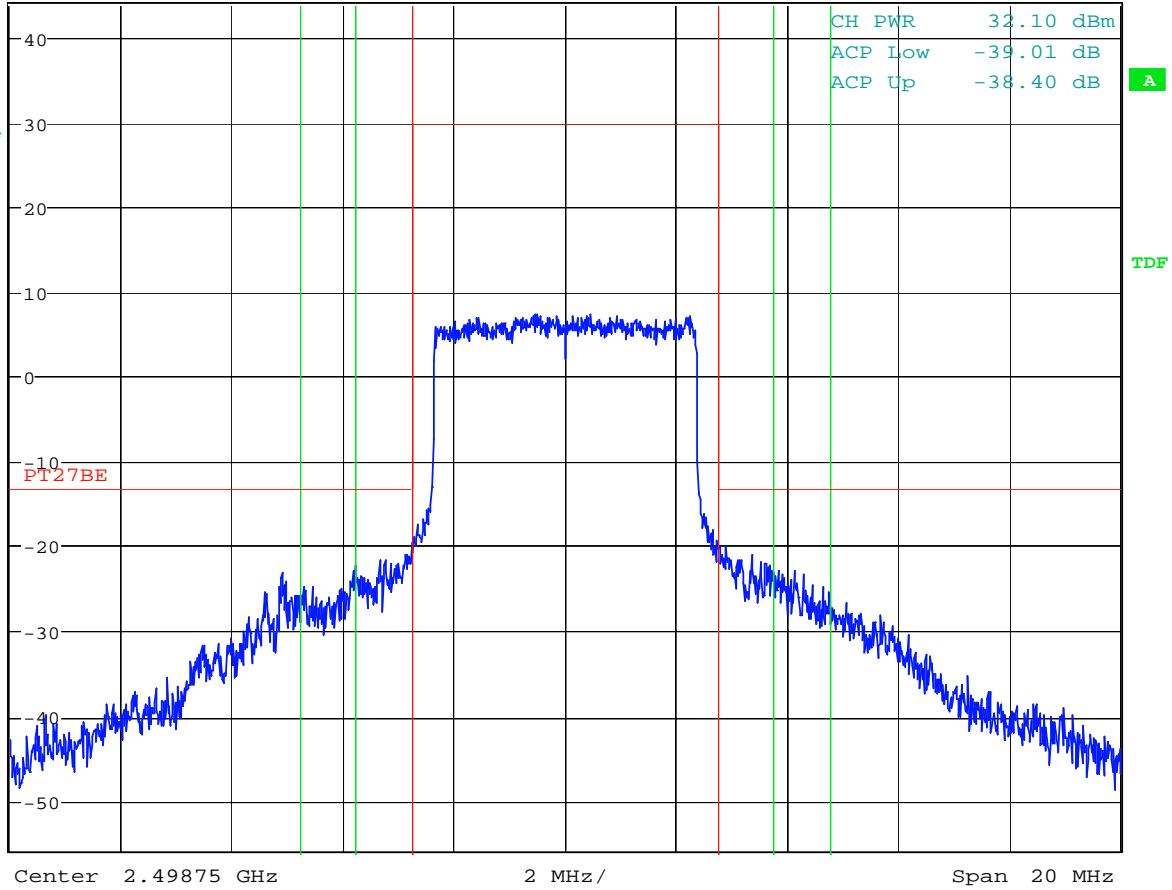

Date: 12.DEC.2007 10:24:59

This report and the information contained herein represent the results of testing test articles identified and selected by the client performed to specifications and/or procedures selected by the client. National Technical Systems (NTS) makes no representations, expressed or implied, that such testing is adequate (or inadequate) to demonstrate efficiency, performance, reliability, or any other characteristic of the articles being tested, or similar products. This report should not be relied upon as an endorsement or certification by NTS of the equipment tested, nor does it represent any statement whatsoever as to its merchantability or fitness of the test article, or similar products, for a particular purpose. This report shall not be reproduced except in full.

Figure 24 +40 ° C, Nominal Voltage (120 VAC) 2498.75 MHz (OFDMA Mode)



* RBW 10 kHz
 * VBW 100 kHz
 * SWT 10 s

Ref 44 dBm * Att 0 dB

1. RM *
 CLRWR

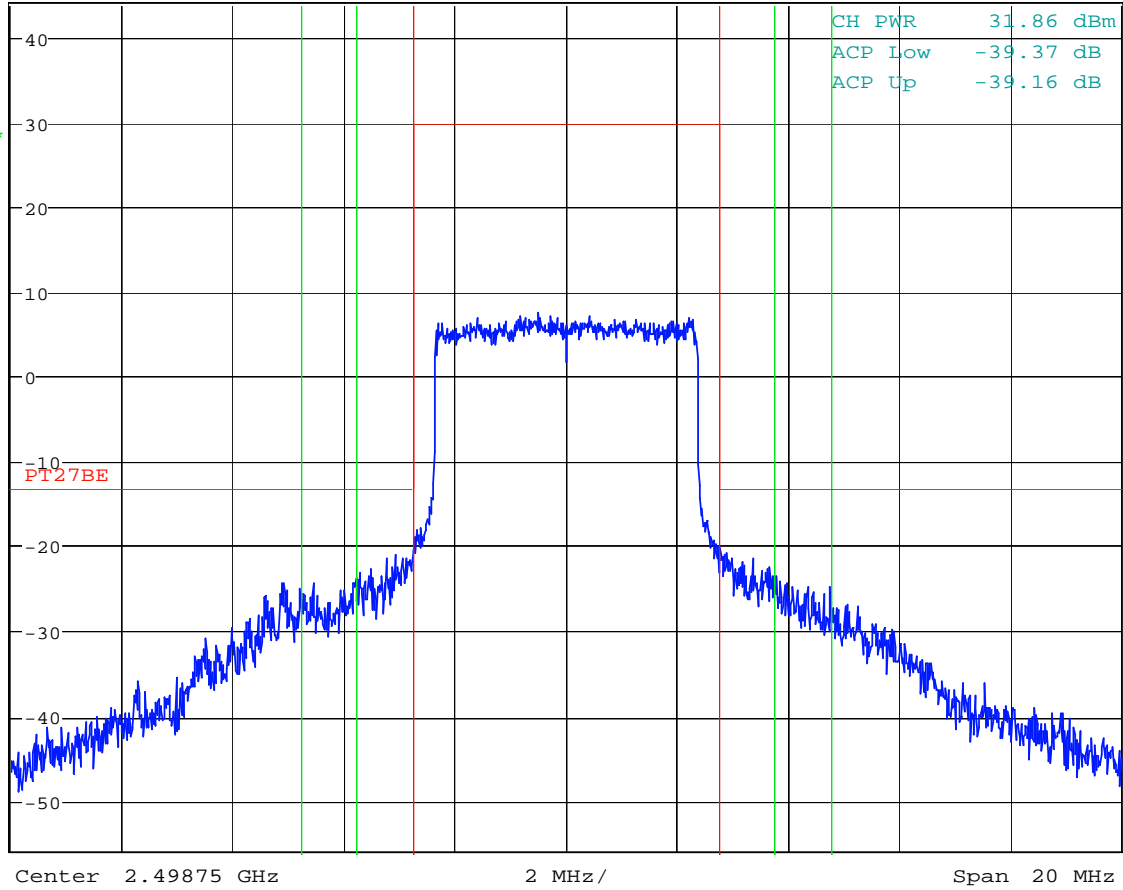

Date: 12.DEC.2007 10:17:53

This report and the information contained herein represent the results of testing test articles identified and selected by the client performed to specifications and/or procedures selected by the client. National Technical Systems (NTS) makes no representations, expressed or implied, that such testing is adequate (or inadequate) to demonstrate efficiency, performance, reliability, or any other characteristic of the articles being tested, or similar products. This report should not be relied upon as an endorsement or certification by NTS of the equipment tested, nor does it represent any statement whatsoever as to its merchantability or fitness of the test article, or similar products, for a particular purpose. This report shall not be reproduced except in full.

Figure 25 +50 ° C, Nominal Voltage (120 VAC) 2498.75 MHz (OFDMA Mode)



* RBW 10 kHz
 VBW 100 kHz
 * SWT 10 s

Ref 44 dBm * Att 0 dB

1 RM *
 CLRWR

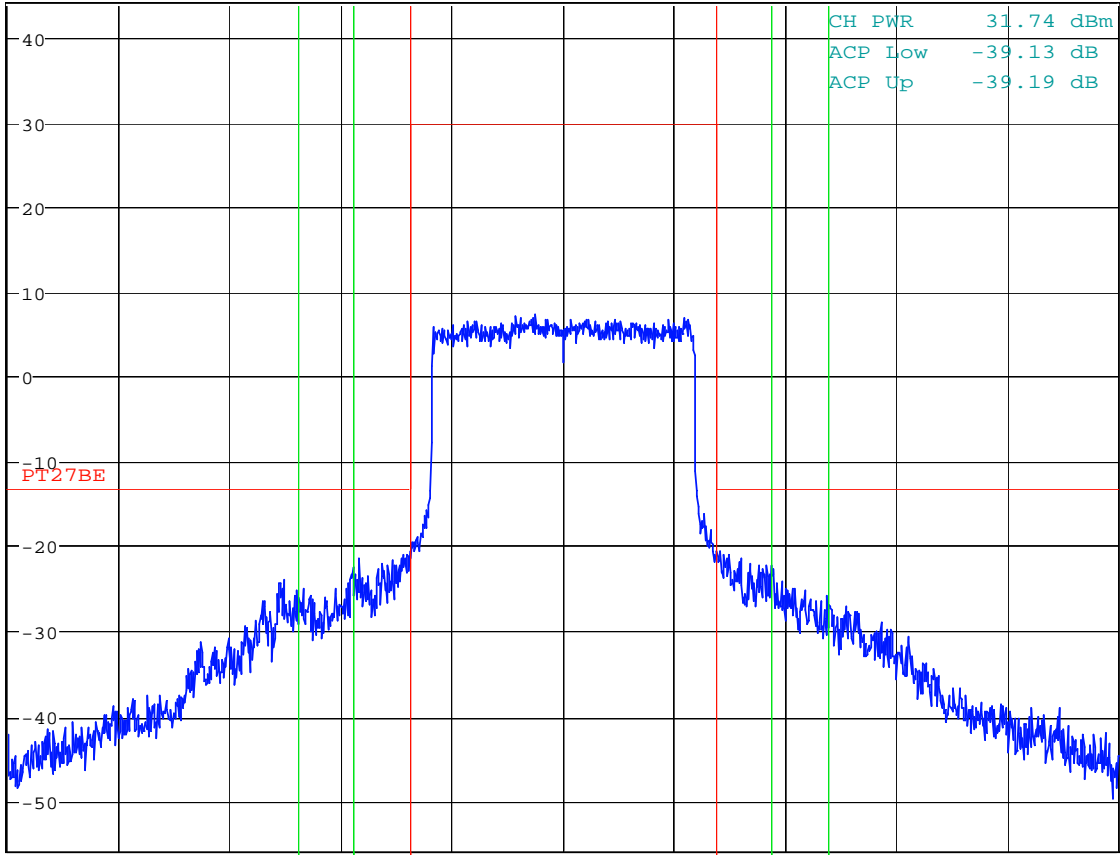

Center 2.49875 GHz 2 MHz / Span 20 MHz

Date: 12.DEC.2007 10:03:32

This report and the information contained herein represent the results of testing test articles identified and selected by the client performed to specifications and/or procedures selected by the client. National Technical Systems (NTS) makes no representations, expressed or implied, that such testing is adequate (or inadequate) to demonstrate efficiency, performance, reliability, or any other characteristic of the articles being tested, or similar products. This report should not be relied upon as an endorsement or certification by NTS of the equipment tested, nor does it represent any statement whatsoever as to its merchantability or fitness of the test article, or similar products, for a particular purpose. This report shall not be reproduced except in full.

**Figure 26 LOW VOLTAGE(102 VAC)/AMBIENT TEMPERATURE (+20 deg. C)
2498.75 MHz (CDMA Mode)**



* RBW 10 kHz
* VBW 100 kHz
* SWT 10 s

Ref 44 dBm

* Att 0 dB

1 RM *
CLRWR

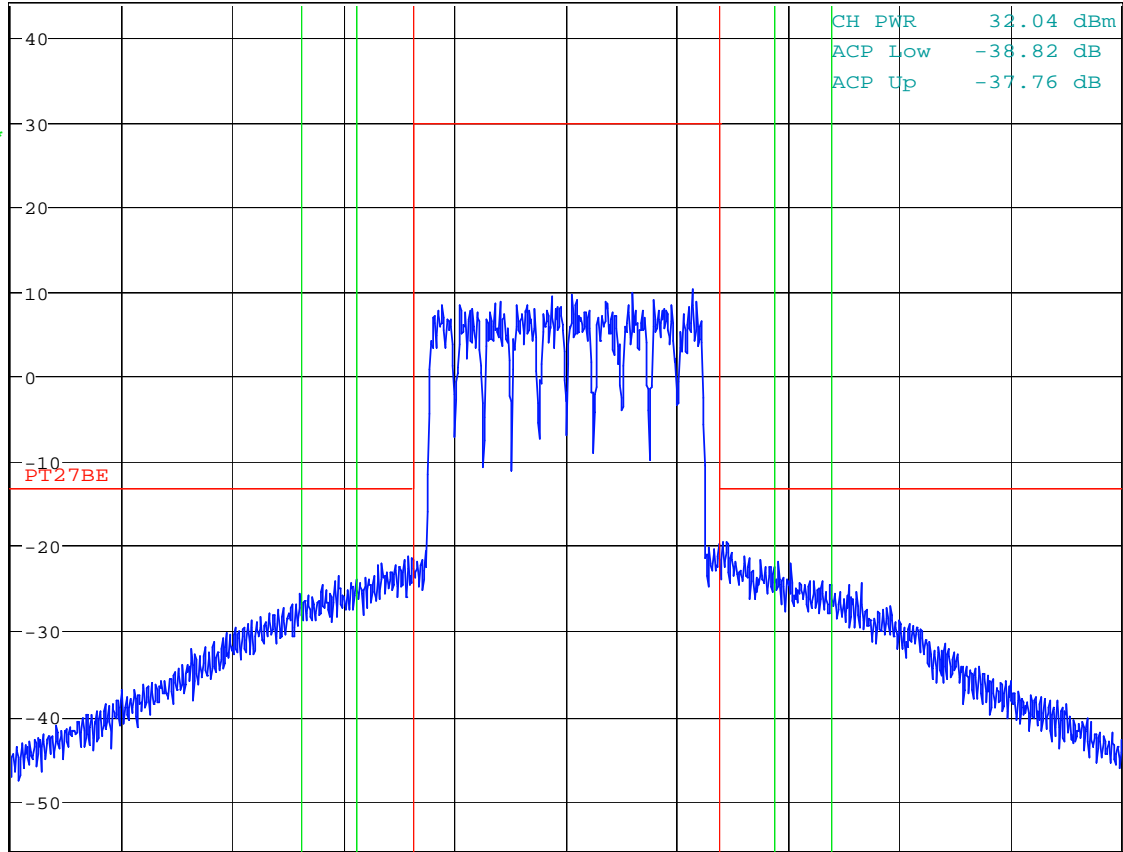

A
FRQ
TDF

Center 2.49875 GHz 2 MHz / Span 20 MHz

Date: 12.DEC.2007 12:57:09

This report and the information contained herein represent the results of testing test articles identified and selected by the client performed to specifications and/or procedures selected by the client. National Technical Systems (NTS) makes no representations, expressed or implied, that such testing is adequate (or inadequate) to demonstrate efficiency, performance, reliability, or any other characteristic of the articles being tested, or similar products. This report should not be relied upon as an endorsement or certification by NTS of the equipment tested, nor does it represent any statement whatsoever as to its merchantability or fitness of the test article, or similar products, for a particular purpose. This report shall not be reproduced except in full.

**Figure 27 HIGH VOLTAGE(138 VAC)/AMBIENT TEMPERATURE (+20 deg. C)
2498.75 MHz (CDMA Mode)**



* RBW 10 kHz
* VBW 100 kHz
* SWT 10 s

Ref 44 dBm

* Att 0 dB

1 RM *
CLRWR

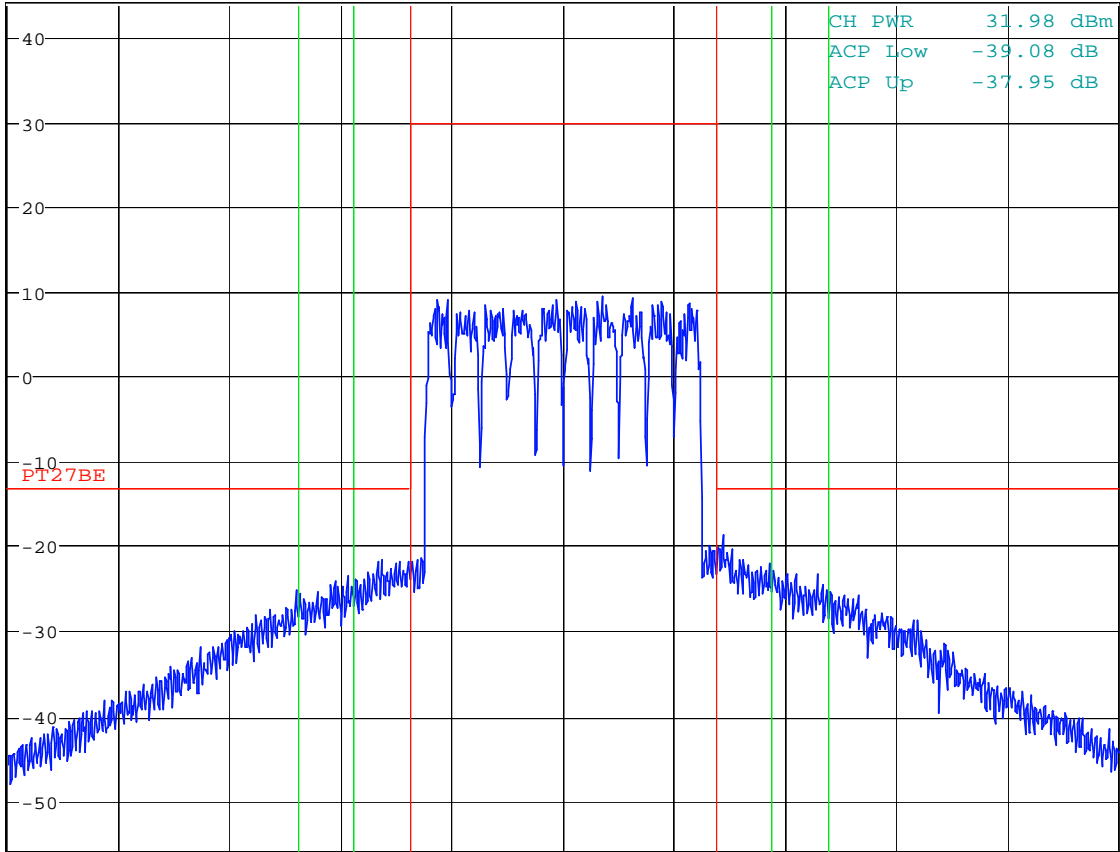

Center 2.49875 GHz 2 MHz / Span 20 MHz

Date: 12.DEC.2007 12:58:20

This report and the information contained herein represent the results of testing test articles identified and selected by the client performed to specifications and/or procedures selected by the client. National Technical Systems (NTS) makes no representations, expressed or implied, that such testing is adequate (or inadequate) to demonstrate efficiency, performance, reliability, or any other characteristic of the articles being tested, or similar products. This report should not be relied upon as an endorsement or certification by NTS of the equipment tested, nor does it represent any statement whatsoever as to its merchantability or fitness of the test article, or similar products, for a particular purpose. This report shall not be reproduced except in full.

Figure 28 0 ° C, Nominal Voltage (120 VAC) 2498.75 MHz (CDMA Mode)



* RBW 10 kHz
 * VBW 100 kHz
 * SWT 10 s

Ref 44 dBm

* Att 0 dB

1 RM *
 CLRWR

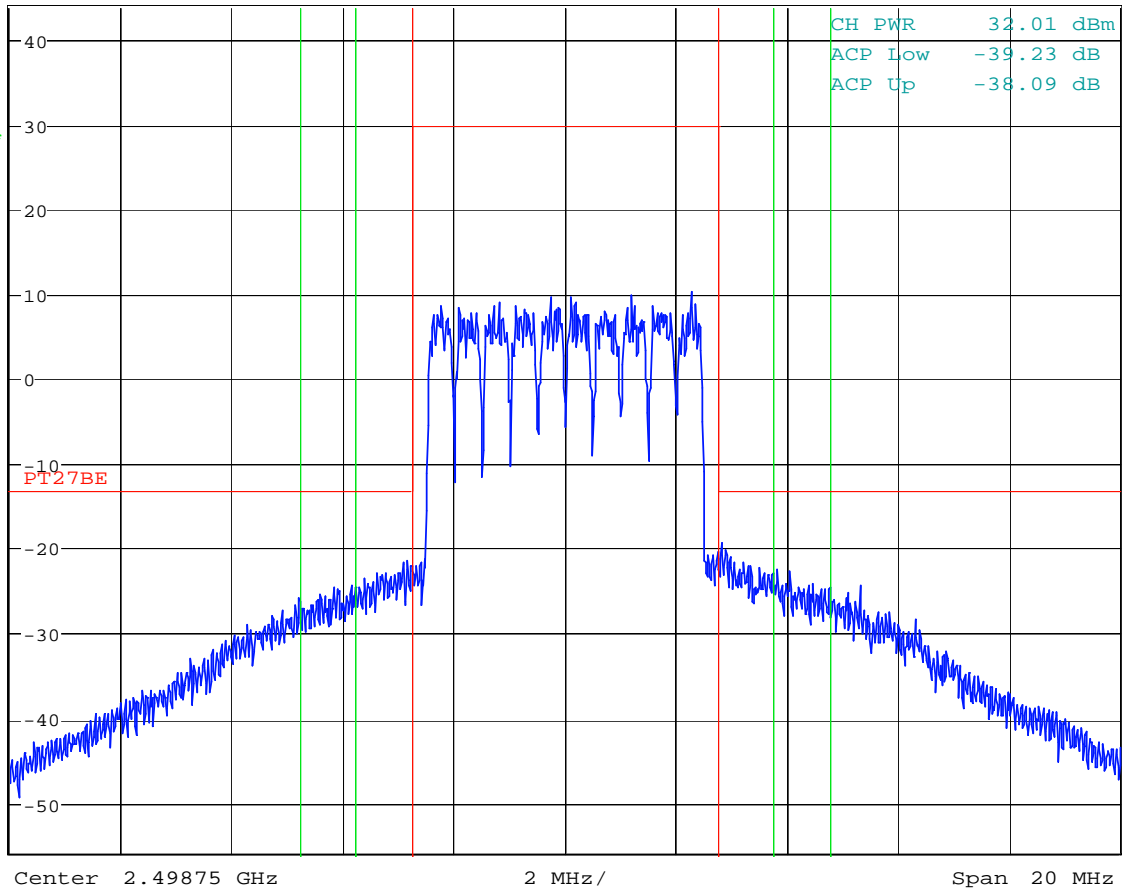

A

FRO
 TDF

Date: 12.DEC.2007 15:30:17

This report and the information contained herein represent the results of testing test articles identified and selected by the client performed to specifications and/or procedures selected by the client. National Technical Systems (NTS) makes no representations, expressed or implied, that such testing is adequate (or inadequate) to demonstrate efficiency, performance, reliability, or any other characteristic of the articles being tested, or similar products. This report should not be relied upon as an endorsement or certification by NTS of the equipment tested, nor does it represent any statement whatsoever as to its merchantability or fitness of the test article, or similar products, for a particular purpose. This report shall not be reproduced except in full.

Figure 29 +10 ° C, Nominal Voltage (120 VAC) 2498.75 MHz (CDMA Mode)



* RBW 10 kHz
 VBW 100 kHz
 * SWT 10 s

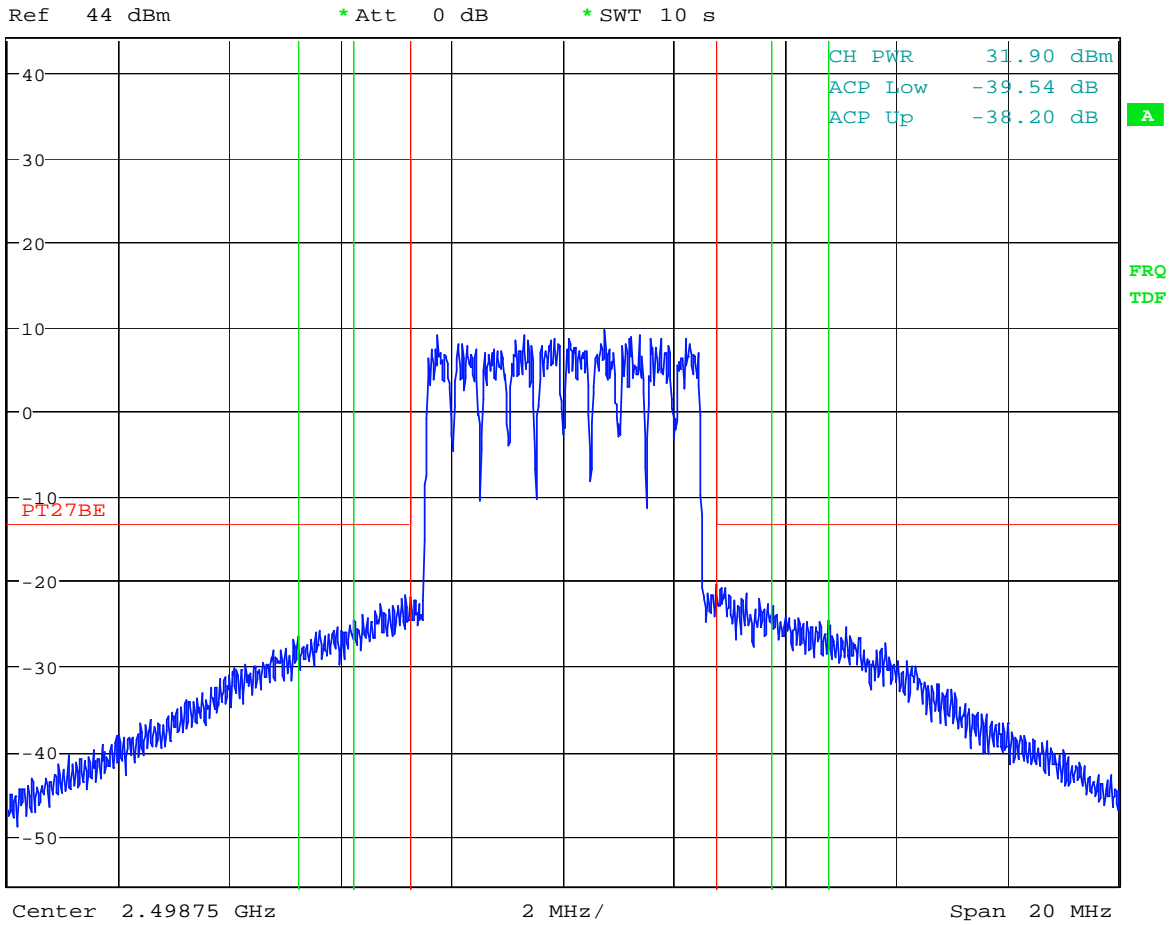

Date: 12.DEC.2007 15:21:34

This report and the information contained herein represent the results of testing test articles identified and selected by the client performed to specifications and/or procedures selected by the client. National Technical Systems (NTS) makes no representations, expressed or implied, that such testing is adequate (or inadequate) to demonstrate efficiency, performance, reliability, or any other characteristic of the articles being tested, or similar products. This report should not be relied upon as an endorsement or certification by NTS of the equipment tested, nor does it represent any statement whatsoever as to its merchantability or fitness of the test article, or similar products, for a particular purpose. This report shall not be reproduced except in full.

Figure 30 +30 ° C, Nominal Voltage (120 VAC) 2498.75 MHz (CDMA Mode)



* RBW 10 kHz
 * VBW 100 kHz
 * SWT 10 s

Ref 44 dBm

* Att 0 dB

1 RM *
 CLRWR

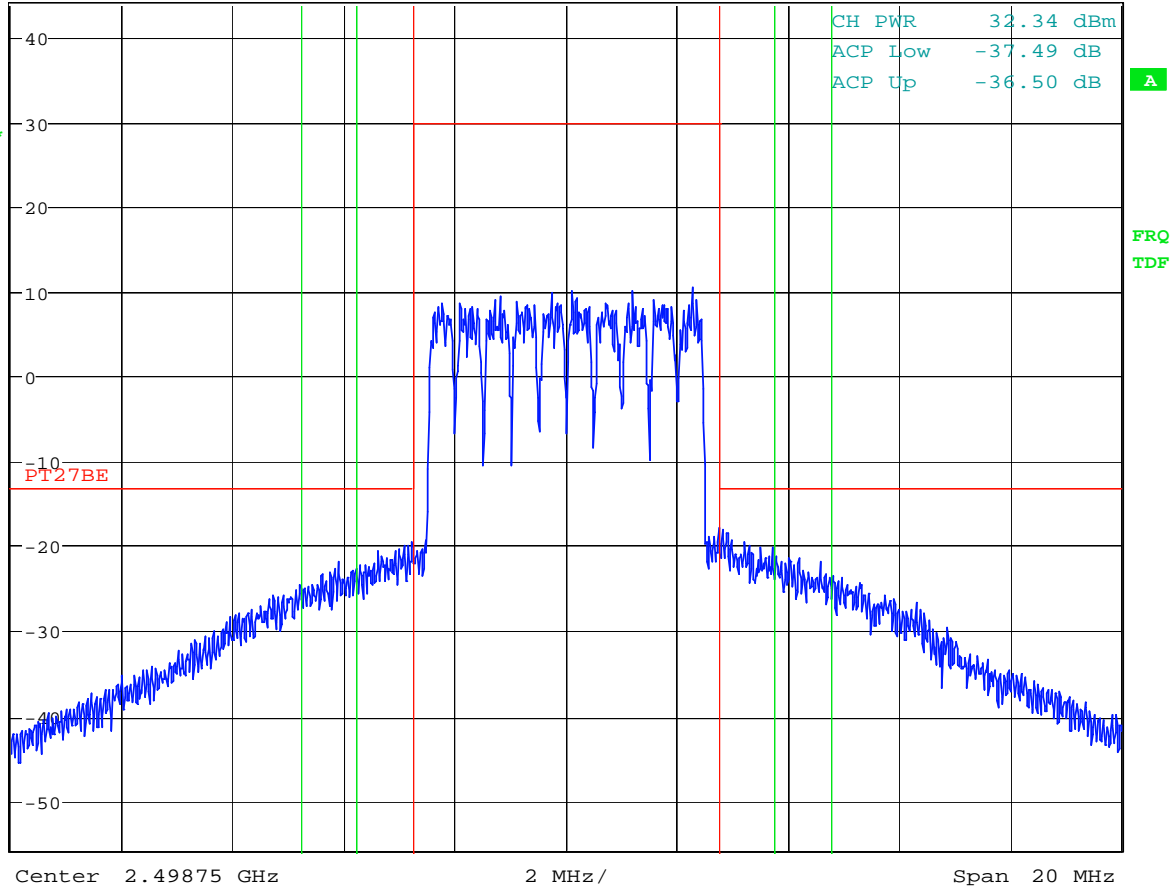

Date: 12.DEC.2007 15:08:43

This report and the information contained herein represent the results of testing test articles identified and selected by the client performed to specifications and/or procedures selected by the client. National Technical Systems (NTS) makes no representations, expressed or implied, that such testing is adequate (or inadequate) to demonstrate efficiency, performance, reliability, or any other characteristic of the articles being tested, or similar products. This report should not be relied upon as an endorsement or certification by NTS of the equipment tested, nor does it represent any statement whatsoever as to its merchantability or fitness of the test article, or similar products, for a particular purpose. This report shall not be reproduced except in full.

Figure 31 +40 ° C, Nominal Voltage (120 VAC) 2498.75 MHz (CDMA Mode)



* RBW 10 kHz
 * VBW 100 kHz
 * SWT 10 s

Ref 44 dBm * Att 0 dB

1 RM *
 CLRWR

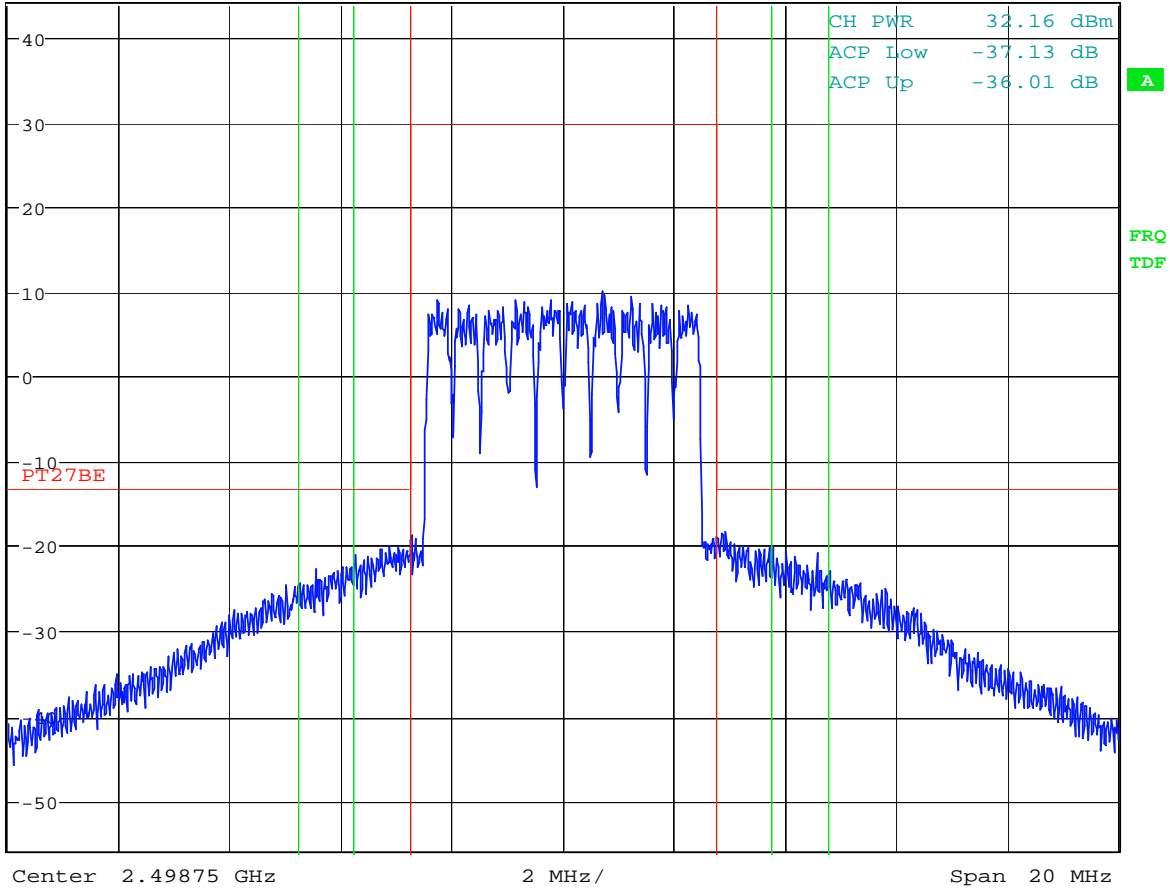

Date: 12.DEC.2007 13:35:52

This report and the information contained herein represent the results of testing test articles identified and selected by the client performed to specifications and/or procedures selected by the client. National Technical Systems (NTS) makes no representations, expressed or implied, that such testing is adequate (or inadequate) to demonstrate efficiency, performance, reliability, or any other characteristic of the articles being tested, or similar products. This report should not be relied upon as an endorsement or certification by NTS of the equipment tested, nor does it represent any statement whatsoever as to its merchantability or fitness of the test article, or similar products, for a particular purpose. This report shall not be reproduced except in full.

Figure 32 +50 ° C, Nominal Voltage (120 VAC) 2498.75 MHz (CDMA Mode)



* RBW 10 kHz
 * VBW 100 kHz
 * SWT 10 s

Ref 44 dBm * Att 0 dB

1 RM *
 CLRWR

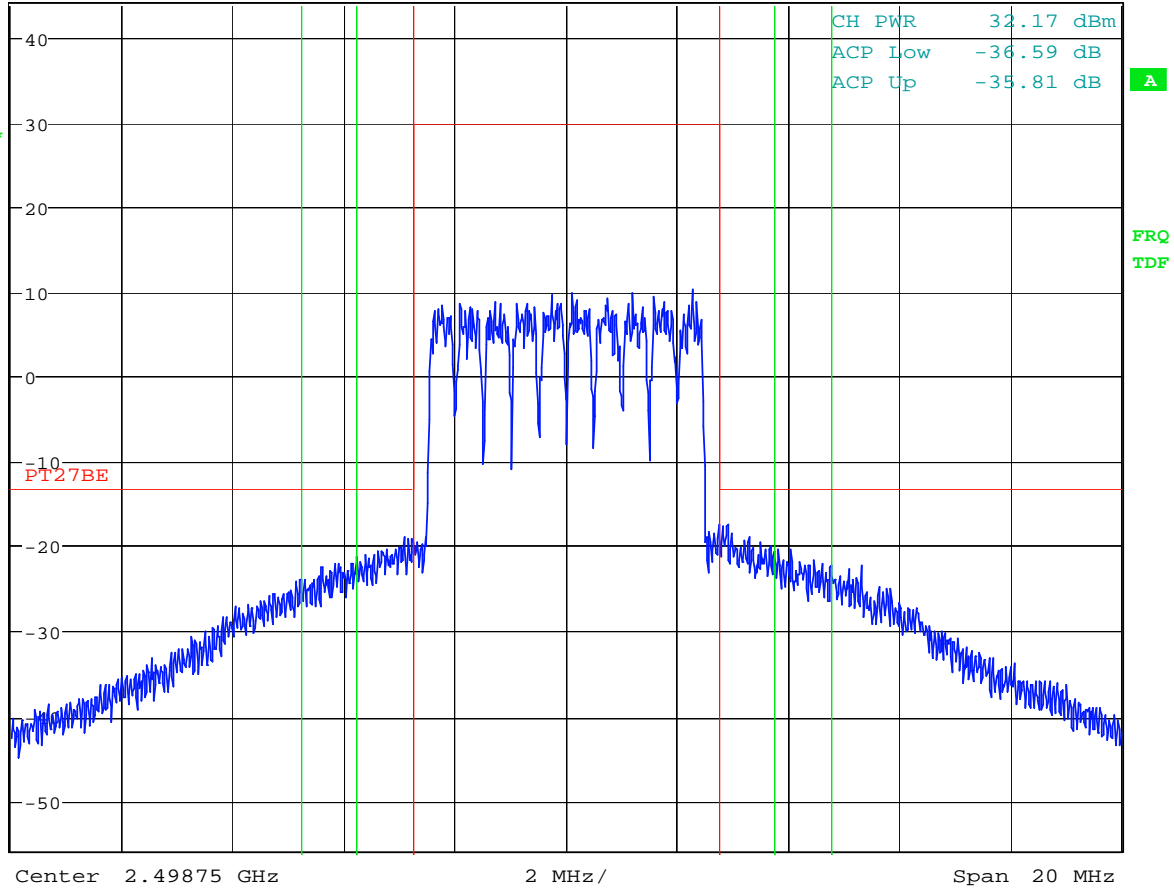

Date: 12.DEC.2007 13:22:18

This report and the information contained herein represent the results of testing test articles identified and selected by the client performed to specifications and/or procedures selected by the client. National Technical Systems (NTS) makes no representations, expressed or implied, that such testing is adequate (or inadequate) to demonstrate efficiency, performance, reliability, or any other characteristic of the articles being tested, or similar products. This report should not be relied upon as an endorsement or certification by NTS of the equipment tested, nor does it represent any statement whatsoever as to its merchantability or fitness of the test article, or similar products, for a particular purpose. This report shall not be reproduced except in full.

APPENDIX G: TEST EQUIPMENT LIST

G.1. Field Strength of Spurious Emissions 30 MHz – 26.5 GHz Measurement Equipment

Description	Manufacturer	Type/Model	Calibration Frequency	Cal Due	NTS Control No.
3m ANECHOIC CHAMBER					
RX Bilog Antenna	ETS	3142C	12 Months	9/21/08	E1288P
Ref. Horn Antenna	ETS	3115	12 Months	9/05/08	E1049P
RX Horn Antenna	ETS	3115	12 Months	9/05/08	E1049P
High Frequency Cable	MegaPhase	TM26-3135-144	12 Months	2/28/08	W1011P
Reference Antenna	ETS	3121 Dipole Set	12 months	12/14/07	E1022P
CONTROL ROOM					
Test Receiver	Rohde & Schwarz	FSQ 26	12 Months	12/31/07	W1020P
High Frequency - Cable 2	MegaPhase	NA	12 Months	8/23/08	W1011P
Amplifier	HP	8449B	12 Months	6/30/08	E1010P

G.2. Antenna Conducted Emissions Measurement Equipment

Instrument	Manufacturer	Model	Calibration Frequency	Calibration Due	NTS Control No.
Spectrum Analyzer	Rohde & Schwarz	FSQ 26	12 Months	12/31/07	W1020P
High Frequency Cable	MegaPhase	TM26-3135-144	12 Months	2/28/08	W1011P
Attenuator - 3 dB	Inmet	26A-3	12 Months	10/24/08	W1016P
Attenuator - 3 dB	Inmet	26A-3	12 Months	10/24/08	W1017P
Attenuator - 10 dB	Wiltron	43KC-10	12 Months	10/24/08	W1018P
Attenuator - 20 dB	Inmet	26A-10	12 Months	10/24/08	W1019P

*This device was not used for calibrated measurements.

This report and the information contained herein represent the results of testing test articles identified and selected by the client performed to specifications and/or procedures selected by the client. National Technical Systems (NTS) makes no representations, expressed or implied, that such testing is adequate (or inadequate) to demonstrate efficiency, performance, reliability, or any other characteristic of the articles being tested, or similar products. This report should not be relied upon as an endorsement or certification by NTS of the equipment tested, nor does it represent any statement whatsoever as to its merchantability or fitness of the test article, or similar products, for a particular purpose. This report shall not be reproduced except in full.

END OF DOCUMENT

This report and the information contained herein represent the results of testing test articles identified and selected by the client performed to specifications and/or procedures selected by the client. National Technical Systems (NTS) makes no representations, expressed or implied, that such testing is adequate (or inadequate) to demonstrate efficiency, performance, reliability, or any other characteristic of the articles being tested, or similar products. This report should not be relied upon as an endorsement or certification by NTS of the equipment tested, nor does it represent any statement whatsoever as to its merchantability or fitness of the test article, or similar products, for a particular purpose. This report shall not be reproduced except in full.

NTS Plano, 1701 E. Plano Pkwy., Plano, TX 75074 Tel: (972) 509-2566, Fax: (972) 509-0073