



Spectrum Research & Testing Lab., Inc.
No. 101-10, Ling 8,
Shan-Tong Li, Chung-Li
City, Taoyuan, Taiwan,
R.O.C.

TEST REPORT

Reference No.:A03031104
Report No.:FCCA02120305-01
FCC ID:PKW-WSB24-2
Page:1 of 67
Date:Mar. 11, 2003

Product Name: Wireless Signal Booster
Model No.: WSB24-2
Applicant: THE LINKSYS GROUP, INC.
17401 ARMSTRONG AVE., IRVINE, CA 92614, U.S.A.
Date of Receipt: Dec. 1, 2002
Finished date of Test: Dec. 4, 2002
Applicable Standards: 47 CFR Part 15, Subpart C
ANSI C63.4:1992

We, **Spectrum Research & Testing Laboratory Inc.**, hereby certify that one sample of the above was tested in our laboratory with positive results according to the above-mentioned standards. The records in the report are an accurate account of the results. Details of the results are given in the subsequent pages of this report.

Checked By : Spring Wang , Date: Mar. 11, 2003
(Spring Wang)

Approved By : Johnson Ho , Date: 3/11/2003
(Johnson Ho, Director)

NVLAQ®

Lab Code: 200099-0



TABLE OF CONTENTS

1.	DOCUMENT POLICY AND TEST STATEMENT	4
1.1	DOCUMENT POLICY	4
1.2	TEST STATEMENT	4
2.	DESCRIPTION OF EUT AND TEST MODE	4
2.1	GENERAL DESCRIPTION OF EUT	4
2.2	DESCRIPTION OF SUPPORT UNIT	5
2.3	DESCRIPTION OF TEST MODE	5
3.	DESCRIPTION OF APPLIED STANDARDS.....	6
4.	TECHNICAL CHARACTERISTICS TEST.....	7
4.1	CONDUCTED EMISSION TEST	7
4.1.1	LIMIT	7
4.1.2	TEST EQUIPMENT	7
4.1.3	TEST SETUP	8
4.1.4	TEST PROCEDURE	8
4.1.5	EUT OPERATING CONDITION	8
4.1.6	TEST RESULT	9
4.2	RADIATED EMISSION TEST	11
4.2.1	LIMIT	11
4.2.2	TEST EQUIPMENT	12
4.2.3	TEST SET-UP	13
4.2.4	TEST PROCEDURE	14
4.2.5	EUT OPERATING CONDITION	14
4.2.6	TEST RESULT	15
4.3	6DBC BANDWIDTH TEST	25
4.3.1	LIMIT	25
4.3.2	TEST EQUIPMENT	25
4.3.3	TEST SET-UP	25
4.3.5	EUT OPERATING CONDITION	25
4.3.6	TEST RESULT	26
4.4	PEAK POWER TEST	32
4.4.1	LIMIT	32
4.4.2	TEST EQUIPMENT	32
4.4.3	TEST SET-UP	33
4.4.5	EUT OPERATING CONDITION	33
4.4.6	TEST RESULT	34
4.5	BAND EDGE TEST	40
4.5.1	LIMIT	40
4.5.2	TEST EQUIPMENT	41
4.5.3	TEST SET-UP	42
4.5.5	EUT OPERATING CONDITION	43
4.5.6	TEST RESULT	44
4.5.6	TEST RESULT	47



Spectrum Research & Testing Lab., Inc.
No. 101-10, Ling 8,
Shan-Tong Li, Chung-Li
City, Taoyuan, Taiwan,
R.O.C.

TEST REPORT

Reference No.:A03031104
Report No.:FCCA02120305-01
FCC ID: PKW-WSB24-2
Page:3 of 67
Date:Mar. 11, 2003

4.6	POWER DENSITY TEST	50
4.6.1	LIMIT	50
4.6.2	TEST EQUIPMENT	50
4.6.3	TEST SET-UP	50
4.6.5	EUT OPERATING CONDITION	50
4.6.6	TEST RESULT	51
4.7	RF POWER EXPOSURE EVALUATION TEST	58
4.7.1	LIMIT	58
4.7.2	TEST EQUIPMENT	59
4.7.3	TEST SET-UP	59
4.7.5	EUT OPERATING CONDITION	60
4.7.6	RESULT	61
5.	ANTENNA APPLICATION	62
5.1	ANTENNA REQUIREMENT	62
5.2	RESULT	62
6.	PHOTOS OF TESTING	63
7.	TERMS OF ABRIVATION	67



1. DOCUMENT POLICY AND TEST STATEMENT

1.1 DOCUMENT POLICY

- The report shall not be reproduced except in full, without the written approval of SRT Lab, Inc.

1.2 TEST STATEMENT

- The test results in the report apply only to the unit tested by SRT Lab.
- There was no deviation from the requirements of test standards during the test.
- AC power source, 120 VAC/60 Hz, was used during the test.

2. DESCRIPTION OF EUT AND TEST MODE

2.1 GENERAL DESCRIPTION OF EUT

PRODUCT	Wireless signal Booster
MODEL NO.	WSB24
POWER SUPPLY	5Vdc from adaptor; Brand : FAIRWAY Model:WN10A-050 Rating:I/P:100-240Vac、 50-60Hz,O/P:5Vdc、 2A
CABLE	RF cable (reverse BNC to reverse SMA) x2
I/O PORT	Reverse SMA connector port x2
FREQUENCY BAND	2400~2483.5MHz
CARRIER FREQUENCY	CH1: 2412MHz~CH11: 2462MHz
NUMBER OF CHANNEL	11
CHANNEL SPACING	5MHz
RATED RF OUTPUT POWER	0.1W
I.F. & L.O.	I.F.: 374MHz, L.O.:2038~2088MHz
MODULATION TYPE	QPSK/BPSK/CCK
BIT RATE OF TRANSMISSION	1, 2, 5, 11Mbps
ANTENNA TYPE	Sleeve dipole

NOTE : The EUT is a signal booster which is designed to combine with wireless AP or Router for normal use. For more detailed features, please refer to the manufacturer's specification or User's Manual of EUT.



2.2 DESCRIPTION OF SUPPORT UNIT

The transmitter part of EUT was tested with a PC system and configured by the requirement of ANSI C63.4. All interface ports were connected to the appropriate support units via specific cables. The support units and cables are listed below.

NO	DEVICE	BRAND	MODEL #	FCC ID / DOC	CABLE
1.	Notebook	DELL	PP01L/ 3F438A01	DOC	1.8m unshielded AC power cable 1.8m unshielded DC power cable
2	Notebook	ACER	MS2110/ 9143U0160C2100AC 7M000	DOC	1.8m unshielded AC power cable 1.8m unshielded DC power cable
3	Wireless Router	LINKSYS	BEFW11S4/ C272B010239	MXF-C901114 MXF-C910308	1.5m unshielded DC power cable
4	Wireless Access Point	LINKSYS	WAP 11 ver 2.6	PKW-WAP11V 26	1.5m unshielded DC power cable
5	Wireless LAN	LINKSYS	WPC11 v2.5	PKW-WPC11- V2	N/A

NOTE : For the actual test configuration, please refer to the photos of testing.

2.3 DESCRIPTION OF TEST MODE

11 channels are provided by EUT. The 3 channels of lower, medium and higher were chosen for test. And the EUT is external radio frequency power amplifier refer to 47 CFR Part 15Section15.204. The EUT was connected to wireless AP or Router during he test. So the test needs to cover two configuration as below

Configuration	Description
1	AP+EUT
2	Router+EUT

There are three test mode for each test configuration as below:

Test mode	Frequency(MHz)
Ch.1	2412
Ch.6	2437
Ch.11	2462

NOTE :

1. Below 1 GHz, the channel 1, 6, and 11 were pre-tested in chamber. The channel 11, worst case one, was chosen for conducted and radiated emission test.
2. Above 1 GHz, the channel 1, 6 and 11 were tested individually



**Spectrum Research &
Testing Lab., Inc.**
No. 101-10, Ling 8,
Shan-Tong Li, Chung-Li
City, Taoyuan, Taiwan,
R.O.C.

TEST REPORT

Reference No.:A03031104
Report No.:FCCA02120305-01
FCC ID: PKW-WSB24-2
Page:6 of 67
Date:Mar. 11, 2003

3. DESCRIPTION OF APPLIED STANDARDS

The EUT is a kind of wireless product and to be connected with a PC system for normal use. According to the specifications provided by the applicant, it must comply with the requirements of the following standards:

47 CFR Part 15, Subpart C

ANSI C63.4:1992

All tests have been performed and recorded as the above standards.



4. TECHNICAL CHARACTERISTICS TEST

4.1 CONDUCTED EMISSION TEST

4.1.1 LIMIT

Frequency (MHz)	Class A (dB μ V)		Class B (dB μ V)	
	Quasi-peak	Average	Quasi-peak	Average
0.15 - 0.5	79	66	66 - 56	56 - 46
0.50 - 5.0	73	60	56	46
5.0 - 30.0	73	60	60	50

NOTE :

1. The lower limit shall apply at the transition frequencies.
2. The limit decreases in line with the logarithm of the frequency in the range of 0.15 to 0.50 MHz.

4.1.2 TEST EQUIPMENT

The following test equipment was used for the test :

EQUIPMENT/ FACILITIES	SPECIFICATIONS	MANUFACTURER	MODEL#/ SERIAL#	DUE DATE OF CAL. & CAL. CENTER
EMI TEST RECEIVER	9 kHz TO 30 MHz	ROHDE & SCHWARZ	ESHS30/ 826003/008	JUL. 2003 R&S
LISN	50 μ H, 50 ohm	SOLAR ELECTRONICS	8012-50-R-24-BNC / 924839	JUN. 2003 ETC
LISN	50 μ H, 50 ohm	SOLAR ELECTRONICS	9252-50-R-24-BNC / 951318	JUN. 2003 ETC

NOTE: The calibration interval of the above test equipment is one year and the calibrations are traceable to NML/ROC and NIST/USA.



4.1.3 TEST SETUP

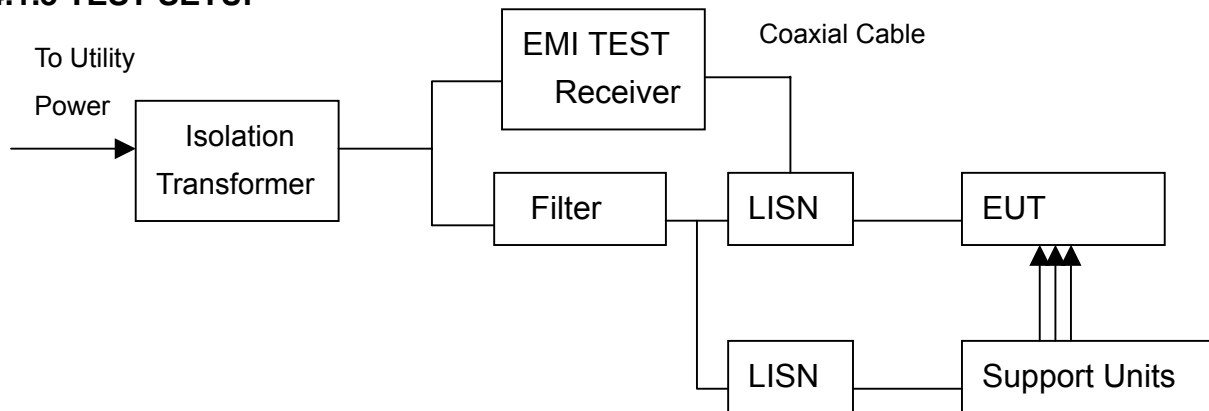

NOTE :

1. The EUT was put on a wooden table with 0.8m height above ground plane, and 0.4m away from reference ground plane (> 2mx2m).
2. For the actual test configuration, please refer to the photos of testing.

4.1.4 TEST PROCEDURE

The EUT was tested according to the requirement of ANSI C63.4 and CISPR 22. The frequency spectrum from 0.15 MHz to 30 MHz was investigated. The LISN used was 50 ohm/50μH as specified. All readings were quasi-peak and average values with 10 kHz resolution bandwidth of the test receiver. The EUT system was operated in all typical methods by users. Both lines of the power mains of EUT were measured and the cables connected to EUT and support units were moved to find the maximum emission levels for each frequency.

4.1.5 EUT OPERATING CONDITION

1. Set the system (configuration 1 or configuration 2) under normal condition continuously at link mode.
2. The system (configuration 1 or configuration 2) was used program to control channel when the EUT was tested RF power and emission.



4.1.6 TEST RESULT

Temperature: 23 °C Humidity: 65 %RH
 Frequency Range: 0.15 – 30 MHz Test Mode: Ch11
 Receiver Detector: Q.P. and AV. Tested By: James Lee
 Configuration : 1

Power Line Measured : Line

Freq. (MHz)	Correct. Factor (dB)	Reading Value (dB μ V)		Emission Level (dB μ V)		Limit (dB μ V)		Margin (dB)	
		Q.P.	AV.	Q.P.	AV.	Q.P.	AV.	Q.P.	AV.
0.193	0.20	43.5	42.0	43.7	42.2	63.9	53.9	-20.2	-11.7
0.373	0.20	34.1	32.6	34.3	32.8	58.4	48.4	-24.1	-15.6
0.730	0.20	32.1	26.3	32.3	26.5	56.0	46.0	-23.7	-19.5
1.420	0.20	42.6	38.9	42.8	39.1	56.0	46.0	-13.2	-6.9
2.910	0.20	29.4	25.0	29.6	25.2	56.0	46.0	-26.4	-20.8
23.080	0.66	32.4	29.0	33.1	29.7	60.0	50.0	-26.9	-20.3

Power Line Measured : Neutral

Freq. (MHz)	Correct. Factor (dB)	Reading Value (dB μ V)		Emission Level (dB μ V)		Limit (dB μ V)		Margin (dB)	
		Q.P.	AV.	Q.P.	AV.	Q.P.	AV.	Q.P.	AV.
0.193	0.20	42.7	40.7	42.9	40.9	63.9	53.9	-21.0	-13.0
0.388	0.20	35.5	33.2	35.7	33.4	58.1	48.1	-22.4	-14.7
0.970	0.20	32.0	28.8	32.2	29.0	56.0	46.0	-23.8	-17.0
1.420	0.20	39.1	37.5	39.3	37.7	56.0	46.0	-16.7	-8.3
2.140	0.20	30.9	24.7	31.1	24.9	56.0	46.0	-24.9	-21.1
23.650	0.67	30.2	28.0	30.9	28.7	60.0	50.0	-29.1	-21.3

NOTE :

1. Measurement uncertainty is less than 2dB
2. Emission level = Reading value + Correction factor
3. Correction Factor = Cable loss + Insertion loss of LISN
4. "": Measurement does not apply for this frequency.
5. Margin value = Emission level - Limit
6. The emission of other frequencies were very low against the limit.
7. "-": The Quasi-peak reading value also meets average limit and measurement with the average detector is unnecessary.



Temperature: 23 °C
Frequency Range: 0.15 – 30 MHz
Receiver Detector: Q.P. and AV.
Configuration : 2

Humidity: 65 %RH
Test Mode: Ch11
Tested By: James Lee

Power Line Measured : Line

Freq. (MHz)	Correct. Factor (dB)	Reading Value (dB μ V)		Emission Level (dB μ V)		Limit (dB μ V)		Margin (dB)	
		Q.P.	AV.	Q.P.	AV.	Q.P.	AV.	Q.P.	AV.
0.194	0.20	35.9	32.8	36.1	33.0	63.9	53.9	-27.8	-20.9
0.370	0.20	34.1	31.3	34.3	31.5	58.5	48.5	-24.2	-17.0
0.600	0.20	35.9	32.2	36.1	32.4	56.0	46.0	-19.9	-13.6
1.447	0.20	38.4	32.3	38.6	32.5	56.0	46.0	-17.4	-13.5
13.650	0.47	38.1	38.0	38.6	38.5	60.0	50.0	-21.4	-11.5
21.906	0.64	33.4	26.0	34.0	26.6	60.0	50.0	-26.0	-23.4

Power Line Measured : Neutral

Freq. (MHz)	Correct. Factor (dB)	Reading Value (dB μ V)		Emission Level (dB μ V)		Limit (dB μ V)		Margin (dB)	
		Q.P.	AV.	Q.P.	AV.	Q.P.	AV.	Q.P.	AV.
0.193	0.20	42.5	40.8	42.7	41.0	63.9	53.9	-21.2	-12.9
0.383	0.20	36.2	32.7	36.4	32.9	58.2	48.2	-21.8	-15.3
1.514	0.20	37.9	32.0	38.1	32.2	56.0	46.0	-17.9	-13.8
5.400	0.32	22.0	20.0	22.3	20.3	60.0	50.0	-37.7	-29.7
13.649	0.47	40.5	36.9	41.0	37.4	60.0	50.0	-19.0	-12.6
20.820	0.62	29.5	22.3	30.1	22.9	60.0	50.0	-29.9	-27.1

NOTE :

1. Measurement uncertainty is less than 2dB
2. Emission level = Reading value + Correction factor
3. Correction Factor = Cable loss + Insertion loss of LISN
4. "*": Measurement does not apply for this frequency.
5. Margin value = Emission level - Limit
6. The emission of other frequencies were very low against the limit.
7. "-": The Quasi-peak reading value also meets average limit and measurement with the average detector is unnecessary.



Spectrum Research & Testing Lab., Inc.
No. 101-10, Ling 8,
Shan-Tong Li, Chung-Li
City, Taoyuan, Taiwan,
R.O.C.

TEST REPORT

Reference No.:A03031104
Report No.:FCCA02120305-01
FCC ID: PKW-WSB24-2
Page:11 of 67
Date:Mar. 11, 2003

4.2 RADIATED EMISSION TEST

4.2.1 LIMIT

FCC Part15, Subpart C Section 15.209 limit of radiated emission for frequency below1000MHz. The emissions from an intentional radiator shall not exceed the field strength levels specified in the following table:

FREQUENCY (MHz)	DISTANCE (m)	FIELD STRENGTH (dB μ V/m)
30 - 88	3	40.0
88 - 216	3	43.5
216 - 960	3	46.0
ABOVE 960	3	54.0

- NOTE :**
1. In the emission tables above , the tighter limit applies at the band edges.
 2. Distance refers to the distance between measuring instrument , antenna , and the closest point of any part of the device or system.

FCC Part 15, Section15.35(b) limit of radiated emission for frequency above 1000 MHz

FREQUENCY (MHz)	Class A (dBuV/m) (at 3m)		Class B (dBuV/m) (at 3m)	
	PEAK	AVERAGE	PEAK	AVERAGE
Above 1000	80.0	60.0	74.0	54.0



Spectrum Research & Testing Lab., Inc.
No. 101-10, Ling 8,
Shan-Tong Li, Chung-Li
City, Taoyuan, Taiwan,
R.O.C.

TEST REPORT

Reference No.:A03031104
Report No.:FCCA02120305-01
FCC ID: PKW-WSB24-2
Page:12 of 67
Date:Mar. 11, 2003

4.2.2 TEST EQUIPMENT

The following test equipment was used during the radiated emission test:

EQUIPMENT/ FACILITIES	SPECIFICATIONS	MANUFACTURER	MODEL#/ SERIAL#	DUE DATE OF CAL. & CAL. CENTER
EMI TEST RECEIVER	9 kHz TO 2750 MHz	ROHDE & SCHWARZ	ESCS30/ 836858/008	DEC. 2002 R&S
SPECTRUM	9KHz-26.5GHz	HP	8953E/ 3710A03220	MAY. 2003 ETC
PRE-AMPLIFIER	1GHz-26.5GHz Gain:30dB	HP	8449B/ 3008A01019	NOV. 2002 ETC
BI-LOG ANTENNA	25 MHz TO 2 GHz	EMCO	3142/9701-1124	JUL. 2003 ETC
HORN ANTENNA	1GHz TO 18GHz	EMCO	3115/ 9602-4681	DEC. 2002 ETC
HORN ANTENNA	15GHz TO 40GHz	EMCO	3116/ 2567	JUL. 2003 ETS
OATS	3 - 10 M measurement	SRT	SRT-1	MAY 2003

NOTE:

1. The calibration interval of the above test equipment is one year and the calibrations are traceable to NML/ROC and NIST/USA.
2. The Open Area Test Site (SRT-1) is registered by FCC with No. 90957 and VCCI with No. R-1081.
3. The Open Area Test Site (SRT-2) is registered by FCC with No. 98458 and VCCI with No. R-1168.



4.2.3 TEST SET-UP

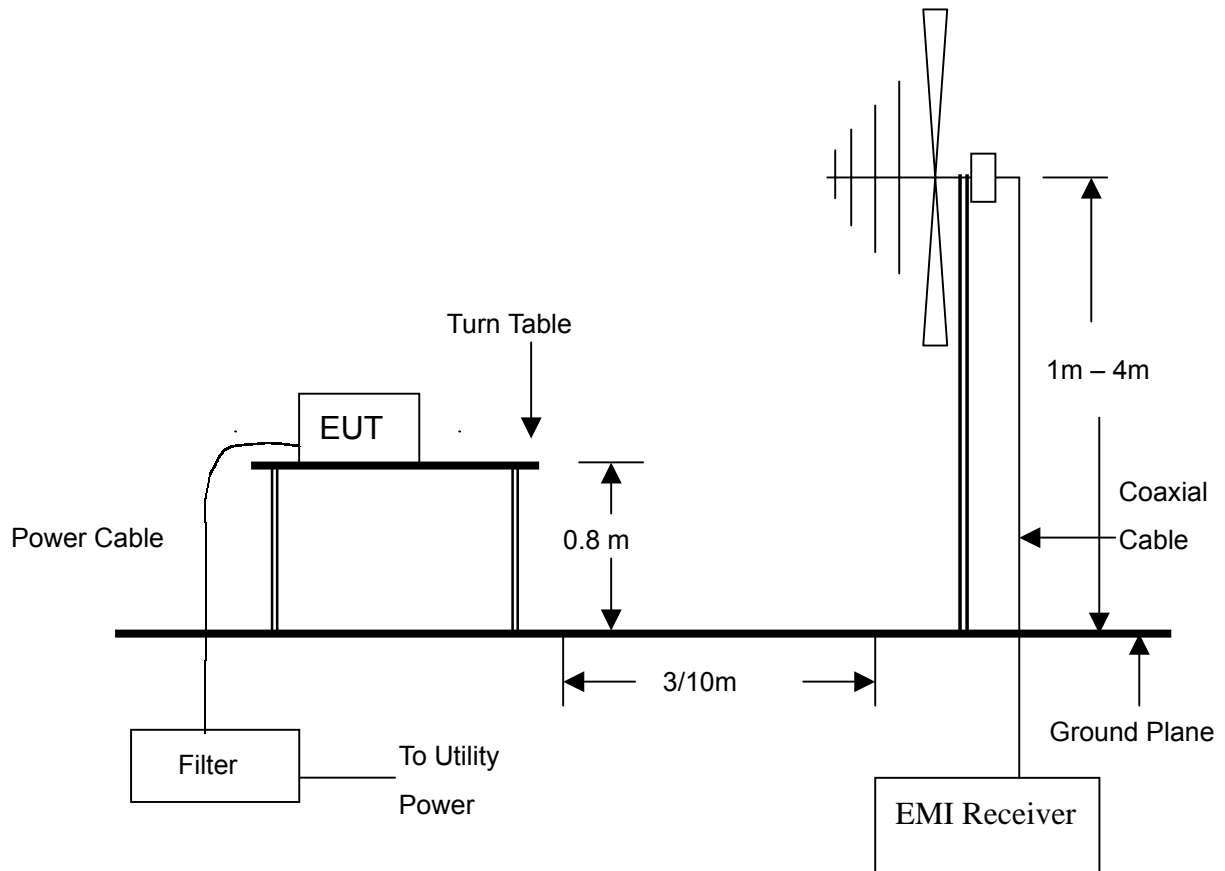

NOTE :

1. The EUT system was put on a wooden table with 0.8m heights above a ground plane.
2. For the actual test configuration, please refer to the photos of testing.



**Spectrum Research &
Testing Lab., Inc.**
No. 101-10, Ling 8,
Shan-Tong Li, Chung-Li
City, Taoyuan, Taiwan,
R.O.C.

TEST REPORT

Reference No.:A03031104
Report No.:FCCA02120305-01
FCC ID: PKW-WSB24-2
Page:14 of 67
Date:Mar. 11, 2003

4.2.4 TEST PROCEDURE

The EUT was tested according to the requirement of ANSI C63.4 and CISPR 22. The measurements were made at an open area test site with 10 meter measurement distance under 1 GHz and with 3m distance above 1GHz. The frequency spectrum measured started from 30 MHz. Under 1 GHz. All readings were quasi-peak values with 120 kHz resolution bandwidth of the test receiver. Above 1 GHz, the measurements were made at an open area test site with 3 meter measurement distance and all readings were peak and average values with 1 MHz resolution bandwidth of the test receiver. The EUT system was operated in all typical methods by users. The cables connected to EUT and support units were moved to find the maximum emission levels for each frequency.

4.2.5 EUT OPERATING CONDITION

Same as section 4.1.5 of this report.



Spectrum Research & Testing Lab., Inc.
No. 101-10, Ling 8,
Shan-Tong Li, Chung-Li
City, Taoyuan, Taiwan,
R.O.C.

TEST REPORT

Reference No.:A03031104
Report No.:FCCA02120305-01
FCC ID: PKW-WSB24-2
Page:15 of 67
Date:Mar. 11, 2003

4.2.6 TEST RESULT

Temperature:	23°C	Humidity:	65%RH
Ferquency Range:	30 – 1000 MHz	Test mode:	Ch11
Receiver Detector:	Q.P.	Measured Distance:	3m
Tested by:	James Lee	Configuration :	1

Antenna Polarization : Horizontal

Frequency (MHz)	Cable Loss (dB)	Antenna Factor (dB/m)	Reading Data (dB μ V)	Emission Level (dB μ V/m)	Limit (dB μ V/m)	Margin (dB)	EL(m)	AZ(°)
250.0095	1.96	12.65	18.2	32.8	46.0	-13.2	320	1.1
300.0112	2.06	14.90	16.3	33.3	46.0	-12.7	350	1.0
325.0132	2.08	15.03	12.0	29.1	46.0	-16.9	350	1.0
350.0132	2.33	15.35	13.5	31.2	46.0	-14.8	353	1.0
375.0125	2.15	15.90	16.2	34.3	46.0	-11.8	360	1.0
499.9820	2.94	17.99	11.8	32.7	46.0	-13.3	0	1.8
625.0180	3.22	20.85	9.0	33.1	46.0	-12.9	18	2.5
649.9735	2.66	20.79	11.4	34.9	46.0	-11.1	30	1.0
659.9835	2.62	20.89	10.4	33.9	46.0	-12.1	237	1.0
747.9820	3.03	21.77	13.0	37.8	46.0	-8.2	246	1.1
749.9840	2.98	21.79	15.2	40.0	46.0	-6.0	267	1.2
799.9650	3.00	22.11	11.0	36.1	46.0	-9.9	278	2.5
849.9650	3.14	22.74	14.4	40.3	46.0	-5.7	263	2.5



Spectrum Research & Testing Lab., Inc.
No. 101-10, Ling 8,
Shan-Tong Li, Chung-Li
City, Taoyuan, Taiwan,
R.O.C.

TEST REPORT

Reference No.:A03031104
Report No.:FCCA02120305-01
FCC ID: PKW-WSB24-2
Page:16 of 67
Date:Mar. 11, 2003

Antenna Polarization : Vertical

Frequency (MHz)	Cable Loss (dB)	Antenna Factor (dB/m)	Reading Data (dB μ V)	Emission Level (dB μ V/m)	Limit (dB μ V/m)	Margin (dB)	EL(m)	AZ(°)
250.0070	1.96	12.65	10.2	24.8	46.0	-21.2	300	1.4
400.0125	2.70	16.30	10.0	29.0	46.0	-17.0	215	1.0
450.0163	2.54	17.05	7.7	27.3	46.0	-18.7	105	1.5
499.9800	2.94	17.99	9.5	30.4	46.0	-15.6	110	1.9
549.9763	3.07	19.23	11.6	33.9	46.0	-12.1	75	1.0
625.0225	3.22	20.85	10.1	34.2	46.0	-11.8	40	1.9
749.9725	2.98	21.79	13.9	38.7	46.0	-7.3	319	1.1
849.9650	3.14	22.74	18.0	43.9	46.0	-2.1	1.2	1.3

- NOTE :**
1. Measurement uncertainty is 4dB
 2. "": Measurement does not apply for this frequency.
 3. Emission Level = Reading Value + Ant. Factor + Cable Loss
 4. The field strength of other emission frequencies were very low against the limit.



Spectrum Research & Testing Lab., Inc.
No. 101-10, Ling 8,
Shan-Tong Li, Chung-Li
City, Taoyuan, Taiwan,
R.O.C.

TEST REPORT

Reference No.:A03031104
Report No.:FCCA02120305-01
FCC ID: PKW-WSB24-2
Page:17 of 67
Date:Mar. 11, 2003

Temperature:	23°C	Humidity:	65%RH
Frequency Range:	30 – 1000 MHz	Test mode:	Ch11
Receiver Detector:	Q.P.	Measured Distance:	3m
Tested by:	James Lee	Configuration :	2

Antenna Polarization : Horizontal

Frequency (MHz)	Cable Loss (dB)	Antenna Factor (dB/m)	Reading Data (dB μ V)	Emission Level (dB μ V/m)	Limit (dB μ V/m)	Margin (dB)	EL(m)	AZ(°)
50.0000	1.07	10.80	5.1	17.0	40.0	-23.0	83	1.1
225.0138	1.81	11.55	14.5	27.9	46.0	-18.1	60	1.2
250.0164	1.96	12.65	20.6	35.2	46.0	-10.8	38	1.2
275.0197	1.92	13.53	12.6	28.0	46.0	-18.0	80	1.0
325.0219	2.08	15.03	9.3	26.4	46.0	-19.6	333	1.1
375.0250	2.15	15.90	12.5	30.6	46.0	-15.5	269	1.0
499.9872	2.94	17.99	13.4	34.3	46.0	-11.7	76	1.6
599.9854	2.71	20.67	19.5	42.9	46.0	-3.1	353	1.2
748.4855	3.01	21.78	7.5	32.3	46.0	-13.7	106	1.0
750.0510	2.95	21.80	10.2	35.0	46.0	-11.1	260	1.0
799.9799	3.00	22.11	13.5	38.6	46.0	-7.4	360	1.6
899.9768	2.88	23.59	9.7	36.2	46.0	-9.8	321	1.7



Spectrum Research & Testing Lab., Inc.
No. 101-10, Ling 8,
Shan-Tong Li, Chung-Li
City, Taoyuan, Taiwan,
R.O.C.

TEST REPORT

Reference No.:A03031104
Report No.:FCCA02120305-01
FCC ID: PKW-WSB24-2
Page:18 of 67
Date:Mar. 11, 2003

Antenna Polarization : Vertical

Frequency (MHz)	Cable Loss (dB)	Antenna Factor (dB/m)	Reading Data (dB μ V)	Emission Level (dB μ V/m)	Limit (dB μ V/m)	Margin (dB)	EL(m)	AZ(°)
50.0000	1.07	10.80	13.0	24.9	46.0	-15.1	0	1.0
250.0178	1.96	12.65	26.9	41.5	46.0	-4.5	92	1.1
300.0221	2.06	14.90	8.8	25.8	46.0	-20.2	26	1.6
325.0221	2.08	15.03	9.1	26.2	46.0	-19.8	30	1.3
349.9921	2.32	15.33	10.7	28.3	46.0	-17.7	250	1.1
399.9891	2.67	16.29	11.6	30.6	46.0	-15.4	77	1.4
449.9886	2.51	17.03	12.3	31.8	46.0	-14.2	61	1.1
499.9841	2.94	17.99	13.4	34.3	46.0	-11.7	140	1.3
599.9841	2.71	20.67	15.0	38.4	46.0	-7.6	90	1.0
649.9836	2.66	20.79	14.8	38.3	46.0	-7.7	200	1.0
748.4851	3.01	21.78	13.0	37.8	46.0	-8.2	30	1.4
750.0510	2.95	21.80	10.3	35.1	46.0	-11.0	343	1.9
899.9768	2.88	23.59	11.9	38.4	46.0	-7.6	75	1.3

- NOTE :**
1. Measurement uncertainty is 4dB
 2. "**": Measurement does not apply for this frequency.
 3. Emission Level = Reading Value + Ant. Factor + Cable Loss
 4. The field strength of other emission frequencies were very low against the limit.



Spectrum Research & Testing Lab., Inc.
 No. 101-10, Ling 8,
 Shan-Tong Li, Chung-Li
 City, Taoyuan, Taiwan,
 R.O.C.

TEST REPORT

Reference No.:A03031104
 Report No.:FCCA02120305-01
 FCC ID: PKW-WSB24-2
 Page:19 of 67
 Date:Mar. 11, 2003

Temperature:	23°C	Humidity:	65%RH
Ferquency Range:	1 – 25 GHz	Test mode:	Ch1
Receiver Detector:	PK. or AV.	Measured Distance:	3m
Tested by:	James Lee	Configuration :	1

Antenna Polarization : Horizontal

Freq./MHz	Correct. Factor (dB)	Ant. Fact. (dB)	Reading (dBuV)		Emission (dBuV/m)		Limit Line (dBuV/m)		Margin (dBuV/m)		AZ (o)	EL (m)
			PK	AV	PK	AV	PK	AV	PK	AV		
2038.25	-32.98	27.28	53.5	50.3	47.8	44.6	74.0	54.0	-26.2	-9.4	187	1.4
2411.35(F)	3.67	28.02	74.0	66.0	105.6	97.7	N/A	N/A	N/A	N/A	121	1.6
4076.00	-30.14	32.47	45.1	33.5	47.4	35.8	74.0	54.0	-26.6	-18.2	258	1.0
4823.95	-30.42	33.66	50.8	43.1	54.0	46.3	74.0	54.0	-20.0	-7.7	93	1.8
7265.50	-29.04	36.31	48.1	36.1	55.4	43.4	74.0	54.0	-18.6	-10.6	165	1.0

Antenna Polarization : Vertical

Freq/MHz	Correct. Factor (dB)	Ant. Fact. (dB)	Reading (dBuV)		Emission (dBuV/m)		Limit Line (dBuV/m)		Margin (dBuV/m)		AZ (o)	EL (m)
			PK	AV	PK	AV	PK	AV	PK	AV		
2038.05	-32.98	27.28	50.8	46.1	45.1	40.4	74.0	54.0	-28.9	-13.6	100	1.0
2412.00(F)	3.67	28.02	85.4	76.4	117.0	108.1	N/A	N/A	N/A	N/A	69	1.0
4076.25	-30.14	32.47	43.9	33.5	46.2	35.8	74.0	54.0	-27.8	-18.2	90	1.0
4824.10	-30.41	33.66	52.4	46.4	55.6	49.6	74.0	54.0	-18.4	-4.4	105	1.1

- NOTE :**
1. Measurement uncertainty is 4dB
 2. "": Measurement does not apply for this frequency.
 3. Emission Level = Reading Value + Ant. Factor + Correct. Factor(incl:Cable Loss and Pre-Amplifier Gain)
 4. The field strength of other emission frequencies were very low against the limit.
 - 5.(F):The field strength of fundamental frequency.



Spectrum Research & Testing Lab., Inc.
 No. 101-10, Ling 8,
 Shan-Tong Li, Chung-Li
 City, Taoyuan, Taiwan,
 R.O.C.

TEST REPORT

Reference No.:A03031104
 Report No.:FCCA02120305-01
 FCC ID: PKW-WSB24-2
 Page:20 of 67
 Date:Mar. 11, 2003

Temperature:	<u>23°C</u>	Humidity:	<u>65%RH</u>
Ferquency Range:	<u>1 – 25 GHz</u>	Test mode:	<u>Ch6</u>
Receiver Detector:	<u>PK. or AV.</u>	Measured Distance:	<u>3m</u>
Tested by:	<u>James Lee</u>	Configuration :	<u>1</u>

Antenna Polarization : Horizontal

Freq./MHz	Correct. Factor (dB)	Ant. Fact. (dB)	Reading (dBuV)		Emission (dBuV/m)		Limit Line (dBuV/m)		Margin (dBuV/m)		AZ (o)	EL (m)
			PK	AV	PK	AV	PK	AV	PK	AV		
2063.03	-32.85	27.33	52.1	47.9	46.5	42.4	74.0	54.0	-27.5	-11.6	193	1.4
2436.45(F)	3.67	28.07	71.1	64.1	102.8	95.8	N/A	N/A	N/A	N/A	68	1.1
4126.78	-30.09	32.74	45.7	33.4	48.3	36.0	74.0	54.0	-25.7	-18.0	199	1.0
4784.00	-30.46	33.63	50.4	42.3	53.6	45.5	74.0	54.0	-20.4	-8.5	232	1.8

Antenna Polarization : Vertical

Freq/MHz	Correct. Factor (dB)	Ant. Fact. (dB)	Reading (dBuV)		Emission (dBuV/m)		Limit Line (dBuV/m)		Margin (dBuV/m)		AZ (o)	EL (m)
			PK	AV	PK	AV	PK	AV	PK	AV		
2062.95	-32.86	27.32	52.8	48.0	47.3	42.5	74.0	54.0	-26.7	-11.5	31	1.1
2436.41(F)	3.67	28.07	82.1	75.6	113.8	107.3	N/A	N/A	N/A	N/A	70	1.0
4124.90	-30.09	32.58	47.2	34.7	49.7	37.2	74.0	54.0	-24.3	-16.8	230	1.0
4873.78	-30.28	33.70	47.7	37.9	51.1	41.3	74.0	54.0	-22.9	-12.7	131	1.5

- NOTE :**
1. Measurement uncertainty is 4dB
 2. "": Measurement does not apply for this frequency.
 3. Emission Level = Reading Value + Ant. Factor + Correct. Factor(incl:Cable Loss and Pre-Amplifier Gain)
 4. The field strength of other emission frequencies were very low against the limit.
 - 5.(F):The field strength of fundamental frequency.



Spectrum Research & Testing Lab., Inc.
No. 101-10, Ling 8,
Shan-Tong Li, Chung-Li
City, Taoyuan, Taiwan,
R.O.C.

TEST REPORT

Reference No.:A03031104
Report No.:FCCA02120305-01
FCC ID: PKW-WSB24-2
Page:21 of 67
Date:Mar. 11, 2003

Temperature:	<u>23°C</u>	Humidity:	<u>65%RH</u>
Ferquency Range:	<u>1 – 25 GHz</u>	Test mode:	<u>Ch11</u>
Receiver Detector:	<u>PK. or AV.</u>	Measured Distance:	<u>3m</u>
Tested by:	<u>James Lee</u>	Configuration :	<u>1</u>

Antenna Polarization : Horizontal

Freq./MHz	Correct. Factor (dB)	Ant. Fact. (dB)	Reading (dBuV)		Emission (dBuV/m)		Limit Line (dBuV/m)		Margin (dBuV/m)		AZ (o)	EL (m)
			PK	AV	PK	AV	PK	AV	PK	AV		
2088.00	-32.59	27.38	53.4	49.9	48.2	44.7	74.0	54.0	-25.8	-9.3	34	1.8
2461.30(F)	3.67	28.12	68.6	54.6	100.4	86.4	N/A	N/A	N/A	N/A	297	1.0
2483.58	-32.19	28.17	56.6	45.7	52.6	41.7	74.0	54.0	-21.4	-12.3	200	1.0
4175.96	-30.12	32.69	47.6	34.4	50.1	37.0	74.0	54.0	-23.9	-17.0	0	1.4

Antenna Polarization : Vertical

Freq/MHz	Correct. Factor (dB)	Ant. Fact. (dB)	Reading (dBuV)		Emission (dBuV/m)		Limit Line (dBuV/m)		Margin (dBuV/m)		AZ (o)	EL (m)
			PK	AV	PK	AV	PK	AV	PK	AV		
2088.04	-32.59	27.38	53.4	50.3	48.2	45.1	74.0	54.0	-25.8	-8.9	141	1.4
2461.25(F)	3.67	28.12	78.4	73.4	110.2	105.2	N/A	N/A	N/A	N/A	345	1.0
2483.58	-32.19	28.17	58.8	47.5	54.8	43.5	74.0	54.0	-19.2	-10.5	347	1.1
4175.92	-30.12	32.69	45.8	-	48.3	-	74.0	54.0	-25.7	-	0	1.0
4924.00	-30.23	33.74	52.6	44.0	56.1	47.5	74.0	54.0	-17.9	-6.5	75	1.5
7385.96	-28.95	36.41	50.1	37.1	57.6	44.6	74.0	54.0	-16.4	-9.4	116	1.2

- NOTE :**
1. Measurement uncertainty is 4dB
 2. "": Measurement does not apply for this frequency.
 - 3."-": The peak value of measurement is below the average limit,so the test with average detector is not necessary.
 4. Emission Level = Reading Value + Ant. Factor + Correct. Factor(incl:Cable Loss and Pre-Amplifier Gain)
 5. The field strength of other emission frequencies were very low against the limit.
 - 6.(F):The field strength of fundamental frequency.



Spectrum Research & Testing Lab., Inc.
 No. 101-10, Ling 8,
 Shan-Tong Li, Chung-Li
 City, Taoyuan, Taiwan,
 R.O.C.

TEST REPORT

Reference No.:A03031104
 Report No.:FCCA02120305-01
 FCC ID: PKW-WSB24-2
 Page:22 of 67
 Date:Mar. 11, 2003

Temperature:	23°C	Humidity:	65%RH
Ferquency Range:	1 – 25 GHz	Test mode:	Ch1
Receiver Detector:	PK. or AV.	Measured Distance:	3m
Tested by:	James Lee	Configuration :	2

Antenna Polarization : Horizontal

Freq./MHz	Correct. Factor (dB)	Ant. Fact. (dB)	Reading (dBuV)		Emission (dBuV/m)		Limit Line (dBuV/m)		Margin (dBuV/m)		AZ (o)	EL (m)
			PK	AV	PK	AV	PK	AV	PK	AV		
2037.75	-32.98	27.27	52.0	47.1	46.3	41.4	74.0	54.0	-27.7	-12.6	347	1.0
2411.35 (F)	3.67	28.56	71.2	66.4	103.4	98.6	N/A	N/A	N/A	N/A	195	1.1
4824.00	-30.41	33.66	47.2	-	50.4	-	74.0	54.0	-23.6	-	0	1.0

Antenna Polarization : Vertical

Freq/MHz	Correct. Factor (dB)	Ant. Fact. (dB)	Reading (dBuV)		Emission (dBuV/m)		Limit Line (dBuV/m)		Margin (dBuV/m)		AZ (o)	EL (m)
			PK	AV	PK	AV	PK	AV	PK	AV		
2037.85	-32.98	27.27	51.6	41.3	45.8	35.6	74.0	54.0	-28.2	-18.4	108	1.0
2411.00(F)	3.67	28.02	78.5	73.1	110.2	104.8	N/A	N/A	N/A	N/A	82	1.3
4824.25	-30.41	33.12	49.1	36.8	51.8	39.5	74.0	54.0	-22.2	-14.5	22	1.0
7237.75	-28.98	36.29	50.5	39.2	57.8	46.5	74.0	54.0	-16.2	-7.5	355	1.0

- NOTE :**
1. Measurement uncertainty is 4dB
 2. "": Measurement does not apply for this frequency.
 3. "-": The peak value of measurement is below the average limit,so the test with average detector is not necessary.
 4. Emission Level = Reading Value + Ant. Factor + Correct. Factor(incl:Cable Loss and Pre-Amplifier Gain)
 5. The field strength of other emission frequencies were very low against the limit.
 - 6.(F):The field strength of fundamental frequency.



Spectrum Research & Testing Lab., Inc.
 No. 101-10, Ling 8,
 Shan-Tong Li, Chung-Li
 City, Taoyuan, Taiwan,
 R.O.C.

TEST REPORT

Reference No.:A03031104
 Report No.:FCCA02120305-01
 FCC ID: PKW-WSB24-2
 Page:23 of 67
 Date:Mar. 11, 2003

Temperature:	<u>23°C</u>	Humidity:	<u>65%RH</u>
Ferquency Range:	<u>1 – 25 GHz</u>	Test mode:	<u>Ch6</u>
Receiver Detector:	<u>PK. or AV.</u>	Measured Distance:	<u>3m</u>
Tested by:	<u>James Lee</u>	Configuration :	<u>2</u>

Antenna Polarization : Horizontal

Freq./MHz	Correct. Factor (dB)	Ant. Fact. (dB)	Reading (dBuV)		Emission (dBuV/m)		Limit Line (dBuV/m)		Margin (dBuV/m)		AZ (o)	EL (m)
			PK	AV	PK	AV	PK	AV	PK	AV		
2062.88	-32.86	27.32	49.3	43.4	43.7	37.9	74.0	54.0	-30.3	-16.1	100	13
2435.83(F)	3.67	28.07	69.7	64.5	101.4	96.2	N/A	N/A	N/A	N/A	191	2.0
4872.63	-30.29	33.70	47.6	-	51.0	-	74.0	54.0	-23.0	-	360	1.6

Antenna Polarization : Vertical

Freq./MHz	Correct. Factor (dB)	Ant. Fact. (dB)	Reading (dBuV)		Emission (dBuV/m)		Limit Line (dBuV/m)		Margin (dBuV/m)		AZ (o)	EL (m)
			PK	AV	PK	AV	PK	AV	PK	AV		
2062.88	-32.86	27.65	55.0	41.6	49.8	36.4	74.0	54.0	-24.2	-17.6	165	1.0
2435.05(F)	3.67	28.77	77.5	71.5	109.9	103.9	N/A	N/A	N/A	N/A	334	1.2
4872.00	-30.29	33.70	49.8	36.7	53.2	40.1	74.0	54.0	-20.8	-13.9	190	1.0

- NOTE :**
1. Measurement uncertainty is 4dB
 2. "": Measurement does not apply for this frequency.
 - 3."-": The peak value of measurement is below the average limit,so the test with average detector is not necessary.
 4. Emission Level = Reading Value + Ant. Factor + Correct. Factor(incl:Cable Loss and Pre-Amplifier Gain)
 5. The field strength of other emission frequencies were very low against the limit.
 - 6.(F):The field strength of fundamental frequency.



Spectrum Research & Testing Lab., Inc.
 No. 101-10, Ling 8,
 Shan-Tong Li, Chung-Li
 City, Taoyuan, Taiwan,
 R.O.C.

TEST REPORT

Reference No.:A03031104
 Report No.:FCCA02120305-01
 FCC ID: PKW-WSB24-2
 Page:24 of 67
 Date:Mar. 11, 2003

Temperature:	23°C	Humidity:	65%RH
Ferquency Range:	1 – 25 GHz	Test mode:	Ch11
Receiver Detector:	PK. or AV.	Measured Distance:	3m
Tested by:	James Lee	Configuration :	2

Antenna Polarization : Horizontal

Freq./MHz	Correct. Factor (dB)	Ant. Fact. (dB)	Reading (dBuV)		Emission (dBuV/m)		Limit Line (dBuV/m)		Margin (dBuV/m)		AZ (o)	EL (m)
			PK	AV	PK	AV	PK	AV	PK	AV		
2087.80	-32.60	27.37	49.5	42.0	44.2	36.8	74.0	54.0	-29.8	-17.2	355	1.2
2463.60(F)	3.67	28.13	68.7	63.5	100.5	95.3	N/A	N/A	N/A	N/A	170	1.0
2483.67	-32.19	28.17	61.3	-36.6	57.3	-40.6	74.0	54.0	-16.7	-94.6	105	1.0
4175.50	-30.12	32.69	47.7	38.5	50.3	41.1	74.0	54.0	-23.7	-12.9	200	1.8

Antenna Polarization : Vertical

Freq/MHz	Correct. Factor (dB)	Ant. Fact. (dB)	Reading (dBuV)		Emission (dBuV/m)		Limit Line (dBuV/m)		Margin (dBuV/m)		AZ (o)	EL (m)
			PK	AV	PK	AV	PK	AV	PK	AV		
2087.80	-32.60	27.37	50.5	44.0	45.3	38.8	74.0	54.0	-28.7	-15.2	345	1.0
2463.60(F)	3.67	28.70	75.3	69.7	107.7	102.1	N/A	N/A	N/A	N/A	300	1.4
2483.67	-32.19	28.74	68.0	53.8	64.6	50.3	74.0	54.0	-9.4	-3.7	350	1.0
4923.75	-30.23	33.74	50.4	38.6	53.9	42.1	74.0	54.0	-20.1	-11.9	182	1.0
7386.05	-28.94	36.41	46.9	36.2	54.4	43.7	74.0	54.0	-19.6	-10.3	180	1.3

- NOTE :**
1. Measurement uncertainty is 4dB
 2. "": Measurement does not apply for this frequency.
 3. Emission Level = Reading Value + Ant. Factor + Correct. Factor(incl:Cable Loss and Pre-Amplifier Gain)
 4. The field strength of other emission frequencies were very low against the limit.
 - 5.(F):The field strength of fundamental frequency.



Spectrum Research & Testing Lab., Inc.
No. 101-10, Ling 8,
Shan-Tong Li, Chung-Li
City, Taoyuan, Taiwan,
R.O.C.

TEST REPORT

Reference No.:A03031104
Report No.:FCCA02120305-01
FCC ID: PKW-WSB24-2
Page:25 of 67
Date:Mar. 11, 2003

4.3 6dBc BANDWIDTH TEST

4.3.1 LIMIT

FCC Part15, Subpart C Section 15.247(2). The minimum 6 dB bandwidth shall be at least 500 kHz.

4.3.2 TEST EQUIPMENT

The following test equipment was used during the test :

EQUIPMENT/ FACILITIES	SPECIFICATIONS	MANUFACTURER	MODEL#/ SERIAL#	DUE DATE OF CAL. & CAL. CENTER
SPECTRUM	9kHz-7GHz	ROHDE & SCHWARZ	FSP7/ 839511/010	MAR. 2003 R & S

NOTE: The calibration interval of the above test equipment is one year and the calibrations are traceable to NML/ROC and NIST/USA.

4.3.3 TEST SET-UP

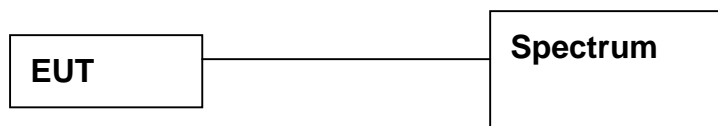

The EUT was connected to a spectrum through a 50 RF cable.

4.3.4 TEST PROCEDURE

The EUT was operating in transmitter mode and could be controlled its channel. Printed out the test result from the spectrum by hard copy function.

4.3.5 EUT OPERATING CONDITION

Same as section 4.1.5 of this report.



Spectrum Research & Testing Lab., Inc.
 No. 101-10, Ling 8,
 Shan-Tong Li, Chung-Li
 City, Taoyuan, Taiwan,
 R.O.C.

TEST REPORT

Reference No.:A03031104
 Report No.:FCCA02120305-01
 FCC ID: PKW-WSB24-2
 Page:26 of 67
 Date:Mar. 11, 2003

4.3.6 TEST RESULT

Temperature:	<u>23°C</u>	Humidity:	<u>60%RH</u>
Spectrum Detector:	<u>PK.</u>	Tested by:	<u>James Lee</u>
Test Result	<u>Pass</u>	Configuration :	<u>1</u>

CHANNEL NUMBER	CHANNEL FREQUENCY (MHz)	6dB DOWN BW (MHz)	MINIMUM LIMIT (MHz)
1	2412	11	0.5
6	2437	10.16	0.5
11	2462	10.16	0.5

CH1:

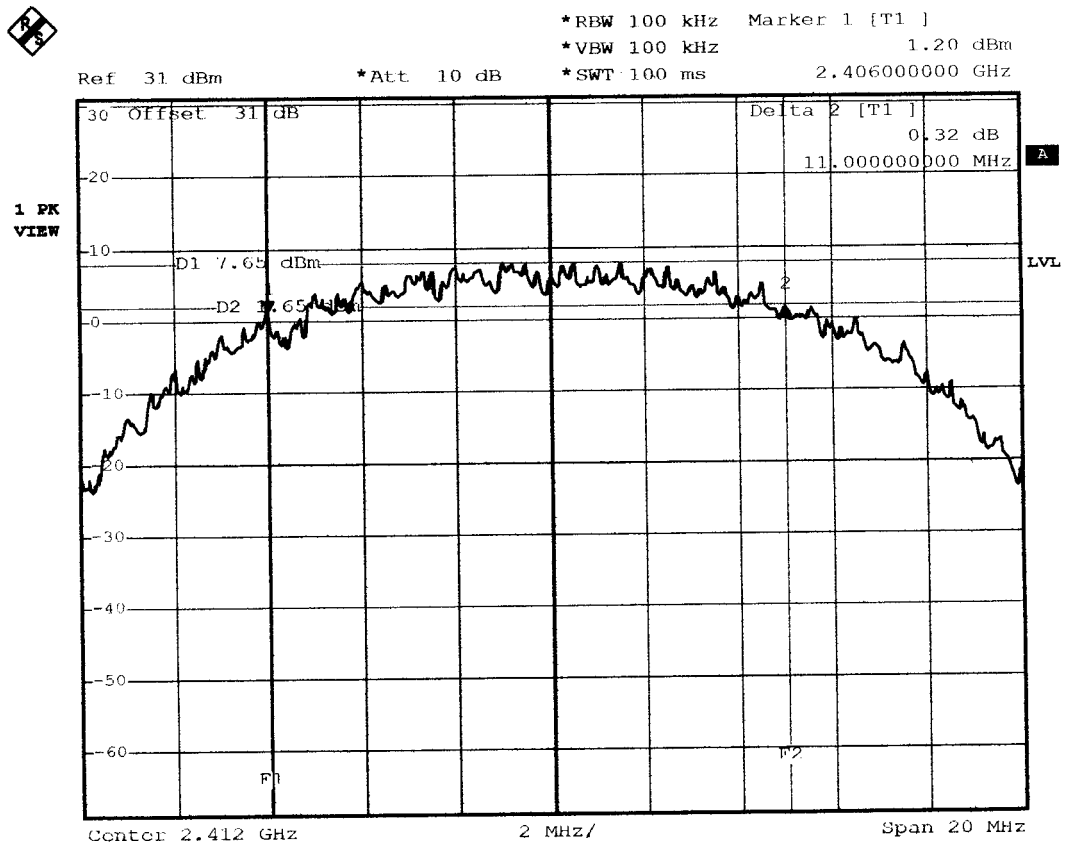

Date: 2.DEC.2002 16:04:18



Spectrum Research & Testing Lab., Inc.
 No. 101-10, Ling 8,
 Shan-Tong Li, Chung-Li
 City, Taoyuan, Taiwan,
 R.O.C.

TEST REPORT

Reference No.:A03031104
 Report No.:FCCA02120305-01
 FCC ID: PKW-WSB24-2
 Page:27 of 67
 Date:Mar. 11, 2003

CH6:

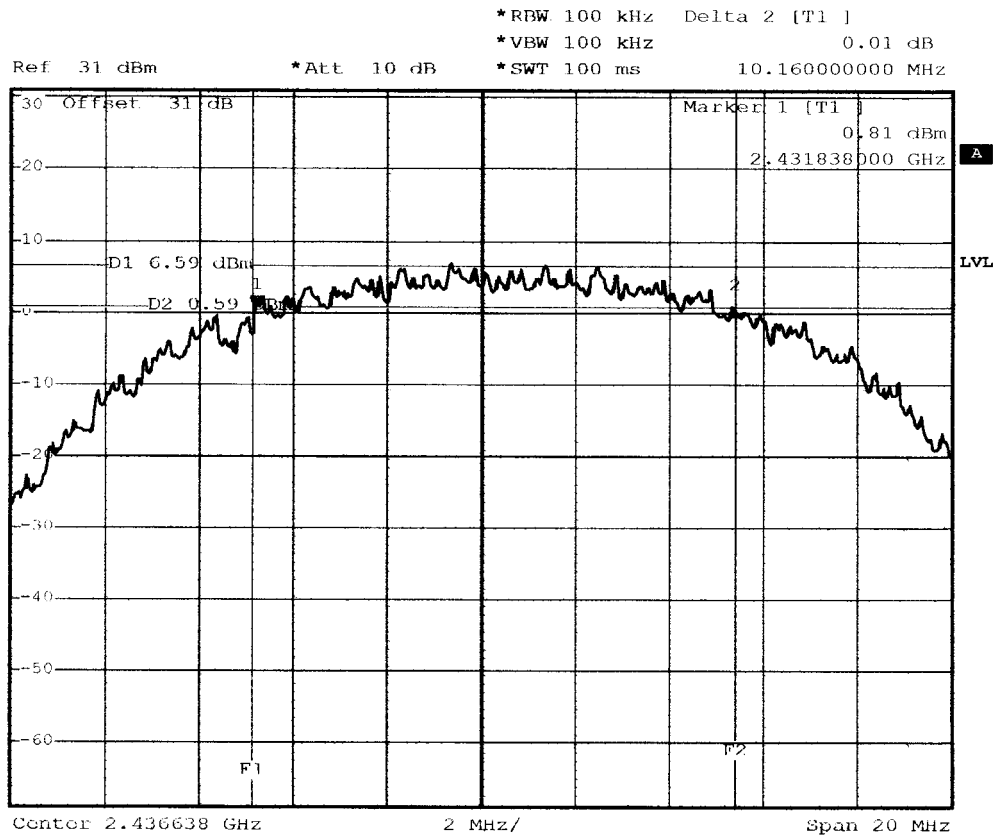

Date: 2.DEC.2002 16:35:36



Spectrum Research & Testing Lab., Inc.
 No. 101-10, Ling 8,
 Shan-Tong Li, Chung-Li
 City, Taoyuan, Taiwan,
 R.O.C.

TEST REPORT

Reference No.:A03031104
 Report No.:FCCA02120305-01
 FCC ID: PKW-WSB24-2
 Page:28 of 67
 Date:Mar. 11, 2003

CH11:

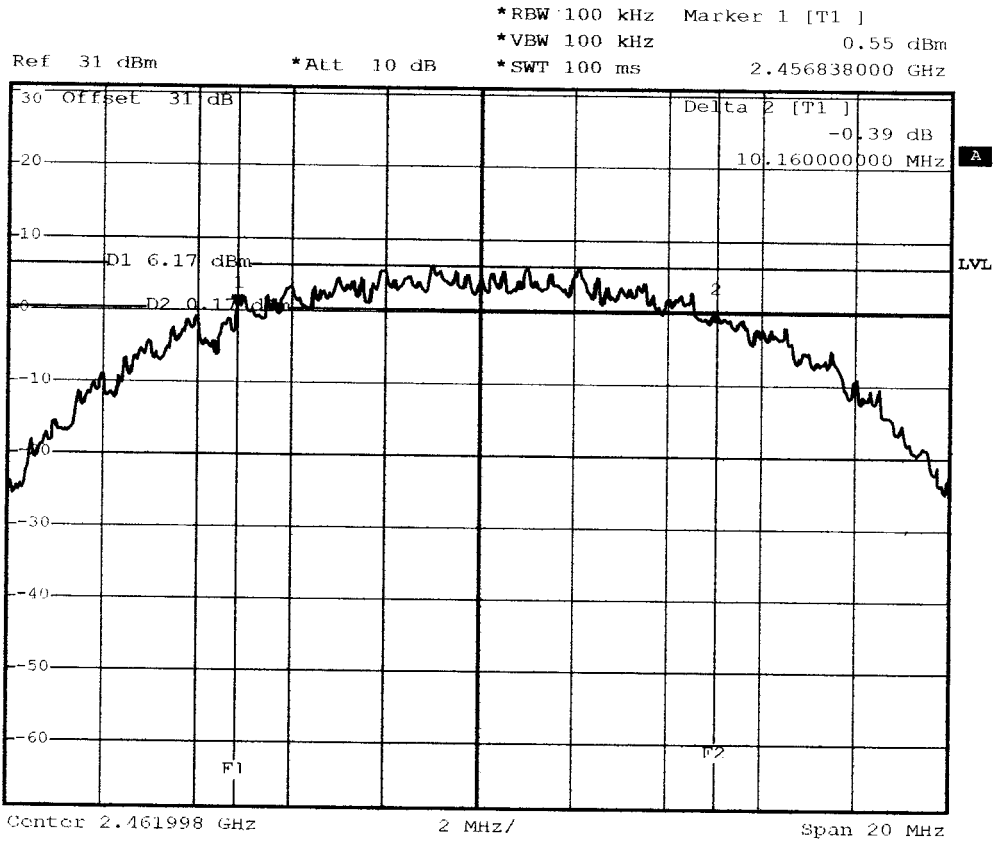

Date: 2.DEC.2002 16:40:00



Spectrum Research & Testing Lab., Inc.
 No. 101-10, Ling 8,
 Shan-Tong Li, Chung-Li
 City, Taoyuan, Taiwan,
 R.O.C.

TEST REPORT

Reference No.:A03031104
 Report No.:FCCA02120305-01
 FCC ID: PKW-WSB24-2
 Page:29 of 67
 Date:Mar. 11, 2003

Temperature:	<u>25°C</u>	Humidity:	<u>60%RH</u>
Spectrum Detector:	<u>PK.</u>	Tested by:	<u>James Lee</u>
Test Result:	<u>Pass</u>	Configuration :	<u>2</u>

CHANNEL NUMBER	CHANNEL FREQUENCY (MHz)	6dB DOWN BW (MHz)	MINIMUM LIMIT (MHz)
1	2412	11.12	0.5
6	2437	11.12	0.5
11	2462	10.72	0.5

CH1:

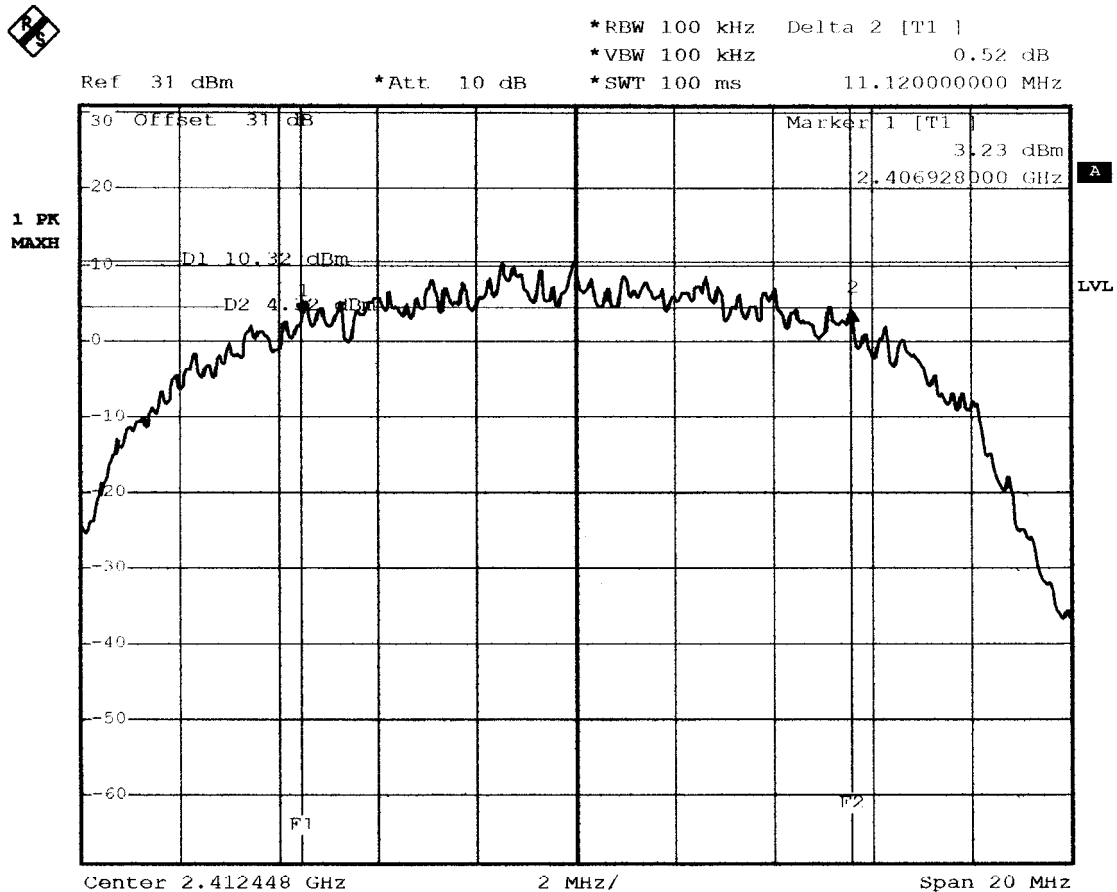

Date: 2.DEC.2002 10:20:39



Spectrum Research & Testing Lab., Inc.
No. 101-10, Ling 8,
Shan-Tong Li, Chung-Li
City, Taoyuan, Taiwan,
R.O.C.

TEST REPORT

Reference No.:A03031104
Report No.:FCCA02120305-01
FCC ID: PKW-WSB24-2
Page:30 of 67
Date:Mar. 11, 2003

CH6:

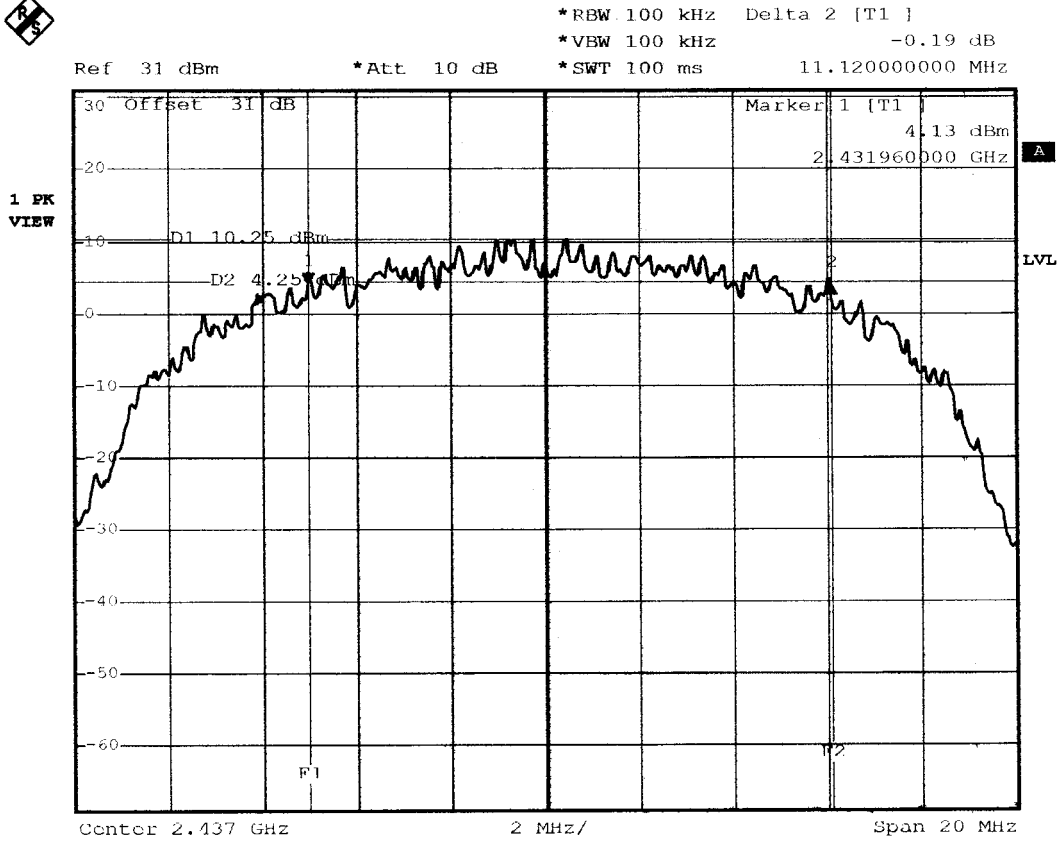

Date: 2.DEC.2002 09:59:45



Spectrum Research & Testing Lab., Inc.
 No. 101-10, Ling 8,
 Shan-Tong Li, Chung-Li
 City, Taoyuan, Taiwan,
 R.O.C.

TEST REPORT

Reference No.:A03031104
 Report No.:FCCA02120305-01
 FCC ID: PKW-WSB24-2
 Page:31 of 67
 Date:Mar. 11, 2003

CH11:



*RBW 100 kHz Marker 1 [T1]
 *VBW 100 kHz 2.66 dBm
 *SWT 100 ms 2.456940000 GHz

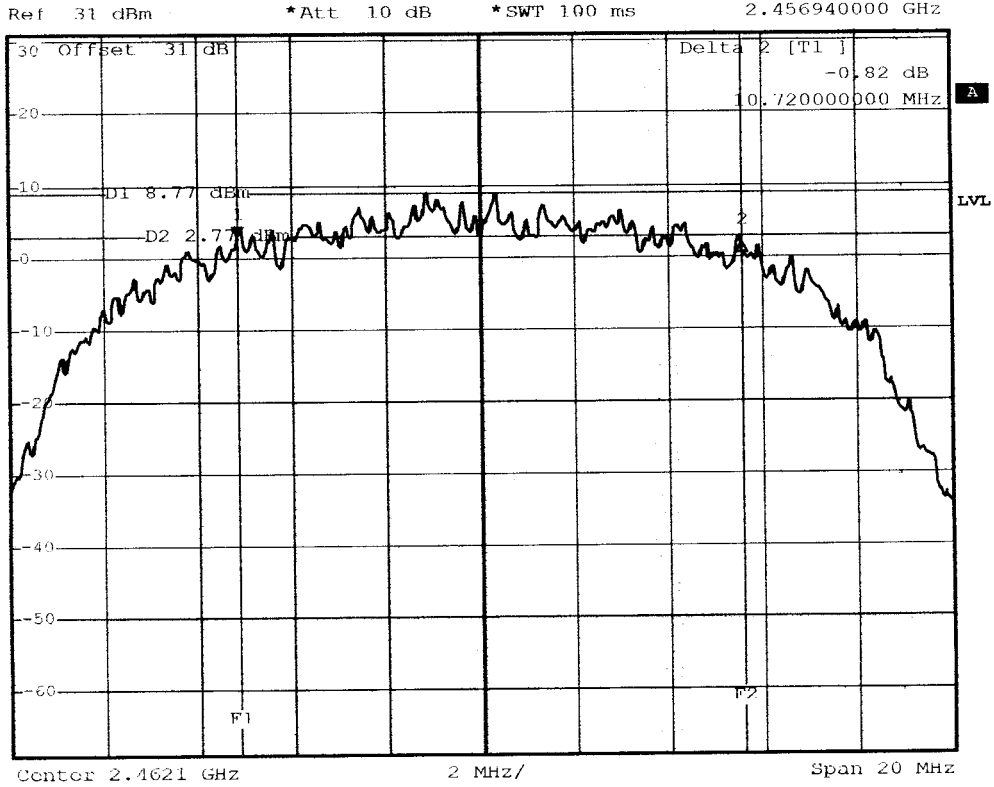

Date: 2.DEC.2002 10:35:03



Spectrum Research & Testing Lab., Inc.
No. 101-10, Ling 8,
Shan-Tong Li, Chung-Li
City, Taoyuan, Taiwan,
R.O.C.

TEST REPORT

Reference No.:A03031104
Report No.:FCCA02120305-01
FCC ID: PKW-WSB24-2
Page:32 of 67
Date:Mar. 11, 2003

4.4 PEAK POWER TEST

4.4.1 LIMIT

FCC Part15, Subpart C Section 15.247.

FREQUENCY RANGE (MHz)	LIMIT (W)
902-928	1(30dBm)
2400-2483.5	1(30dBm)
5725-5850	1(30dBm)

4.4.2 TEST EQUIPMENT

The following test equipment was used during the test:

EQUIPMENT/ FACILITIES	SPECIFICATIONS	MANUFACTURER	MODEL#/ SERIAL#	DUE DATE OF CAL. & CAL. CENTER
SPECTRUM	9kHz-7GHz	ROHDE & SCHWARZ	FSP7/ 839511/010	MAR. 2003 R & S
POWER METER	N/A	BOONTON	4232A/ 29001	MAY 2003 ETC
POWER SENSOR	DC-8GHz 50 Ω	BOONTON	51011EMC/ 31181	MAY 2003 ETC

NOTE: The calibration interval of the above test equipment is one year and the calibrations are traceable to NML/ROC and NIST/USA.



4.4.3 TEST SET-UP

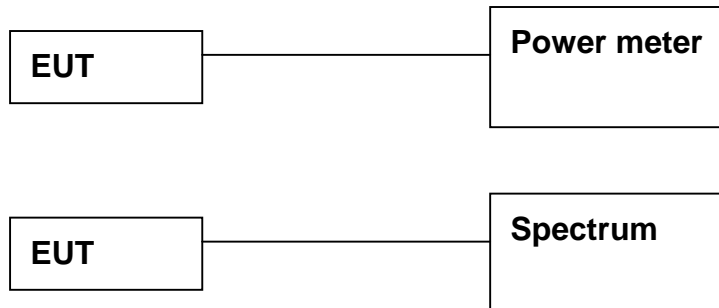

The EUT was connected to a spectrum through a 50 RF cable.

4.4.4 TEST PROCEDURE

The EUT was operating in transmitter mode and could be controlled its channel.
Printed out the test result from the spectrum by hard copy function.
Recorded the read value of the power meter.

4.4.5 EUT OPERATING CONDITION

Same as section 4.1.5 of this report.



Spectrum Research & Testing Lab., Inc.
 No. 101-10, Ling 8,
 Shan-Tong Li, Chung-Li
 City, Taoyuan, Taiwan,
 R.O.C.

TEST REPORT

Reference No.:A03031104
 Report No.:FCCA02120305-01
 FCC ID: PKW-WSB24-2
 Page:34 of 67
 Date:Mar. 11, 2003

4.4.6 TEST RESULT

Temperature:	<u>23°C</u>	Humidity:	<u>65%RH</u>
Spectrum Detector:	<u>PK.</u>	Tested by:	<u>James Lee</u>
Test Result	<u>Pass</u>	Configuration :	<u>1</u>

CHANNEL NUMBER	CHANNEL FREQUENCY (MHz)	PEAK POWER OUTPUT (dBm)	PEAK POWER LIMIT (dBm)
1	2411.76	19.66	30
6	2437.00	18.57	30
11	2462.06	17.9	30

CH1:

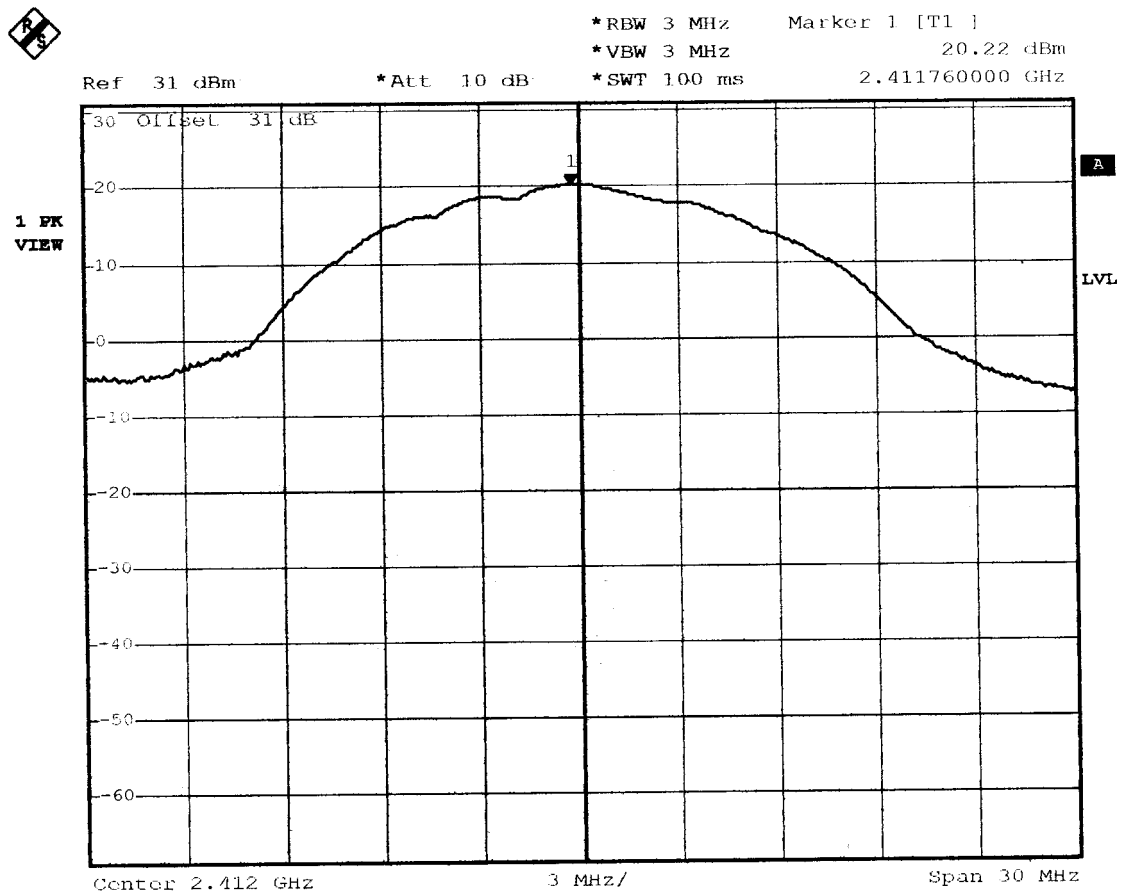

Date: 2.DEC.2002 16:00:37



Spectrum Research & Testing Lab., Inc.
No. 101-10, Ling 8,
Shan-Tong Li, Chung-Li
City, Taoyuan, Taiwan,
R.O.C.

TEST REPORT

Reference No.:A03031104
Report No.:FCCA02120305-01
FCC ID: PKW-WSB24-2
Page:35 of 67
Date:Mar. 11, 2003

CH6:

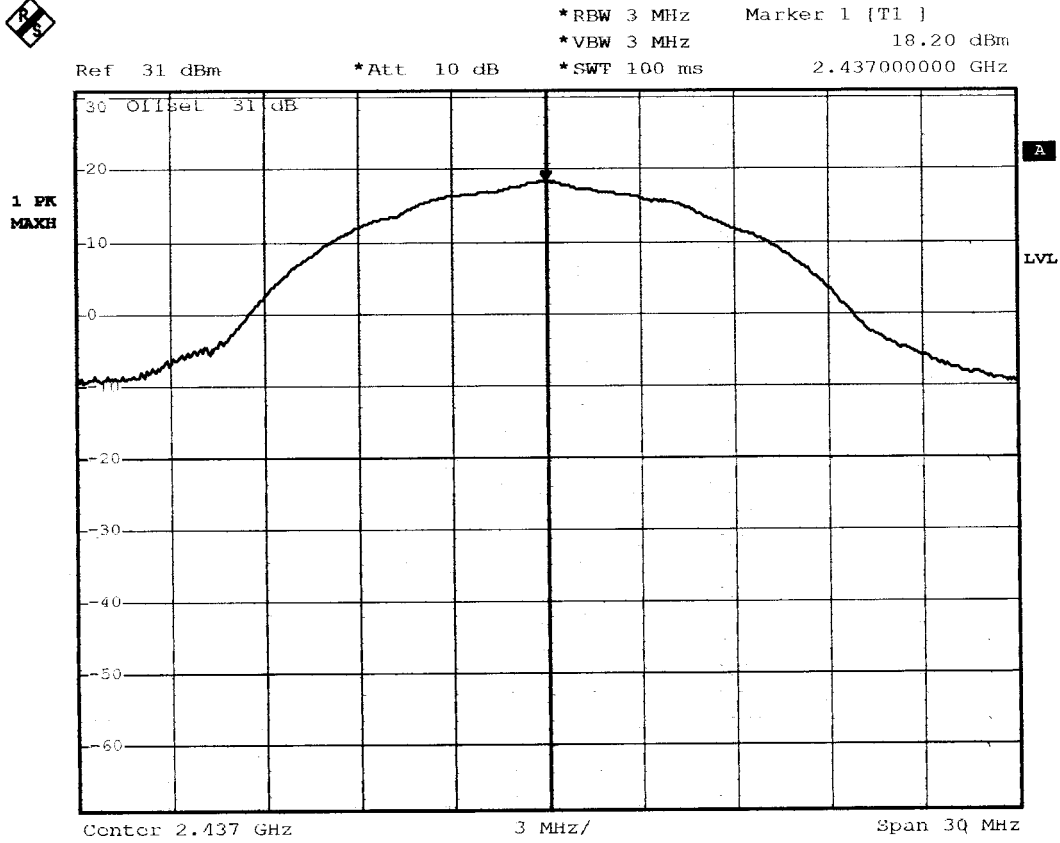

Date: 2.DEC.2002 16:24:48

0.7



Spectrum Research & Testing Lab., Inc.
No. 101-10, Ling 8,
Shan-Tong Li, Chung-Li
City, Taoyuan, Taiwan,
R.O.C.

TEST REPORT

Reference No.:A03031104
Report No.:FCCA02120305-01
FCC ID: PKW-WSB24-2
Page:36 of 67
Date:Mar. 11, 2003

CH11:

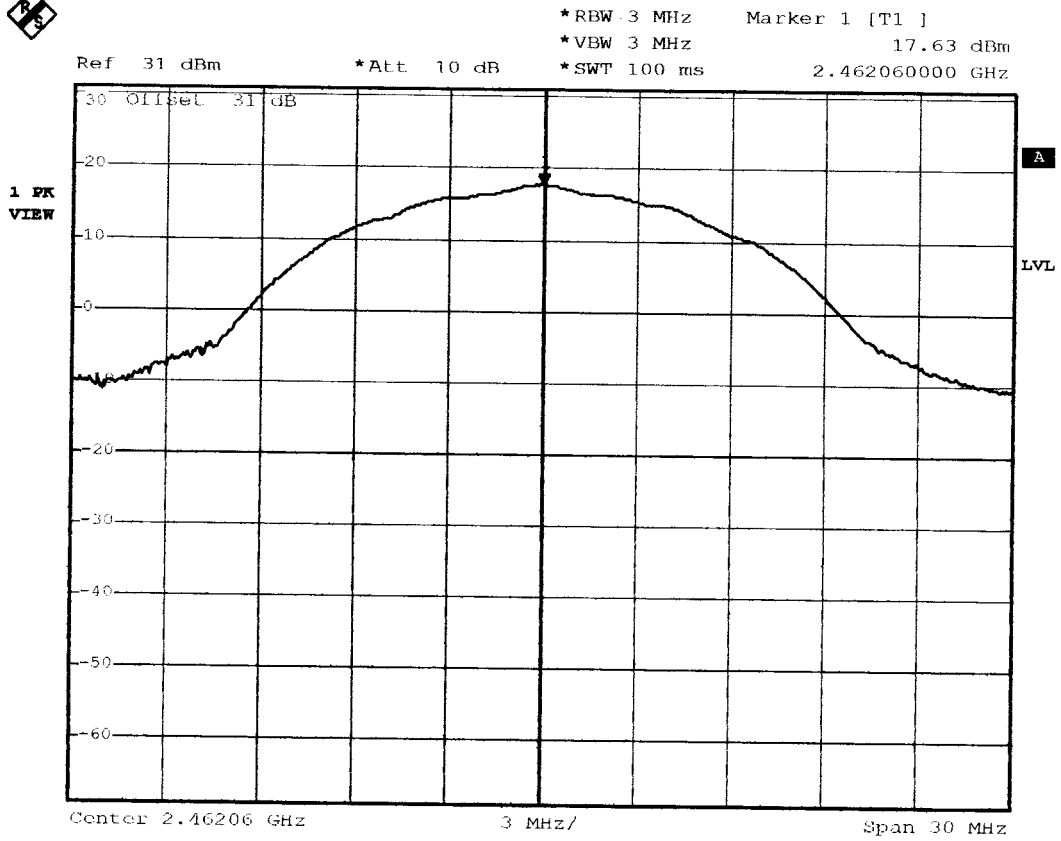

Date: 2.DEC.2002 16:46:14



Spectrum Research & Testing Lab., Inc.
 No. 101-10, Ling 8,
 Shan-Tong Li, Chung-Li
 City, Taoyuan, Taiwan,
 R.O.C.

TEST REPORT

Reference No.:A03031104
 Report No.:FCCA02120305-01
 FCC ID: PKW-WSB24-2
 Page:37 of 67
 Date:Mar. 11, 2003

Temperature:	<u>23°C</u>	Humidity:	<u>65%RH</u>
Spectrum Detector:	<u>PK.</u>	Tested by:	<u>James Lee</u>
Test Result:	<u>Pass</u>	Configuration :	<u>2</u>

CHANNEL NUMBER	CHANNEL FREQUENCY (MHz)	PEAK POWER OUTPUT (dBm)	PEAK POWER LIMIT (dBm)
1	2411.9680	20.5	30
6	2436.7200	20.8	30
11	2462.0864	18.7	30

CH1:

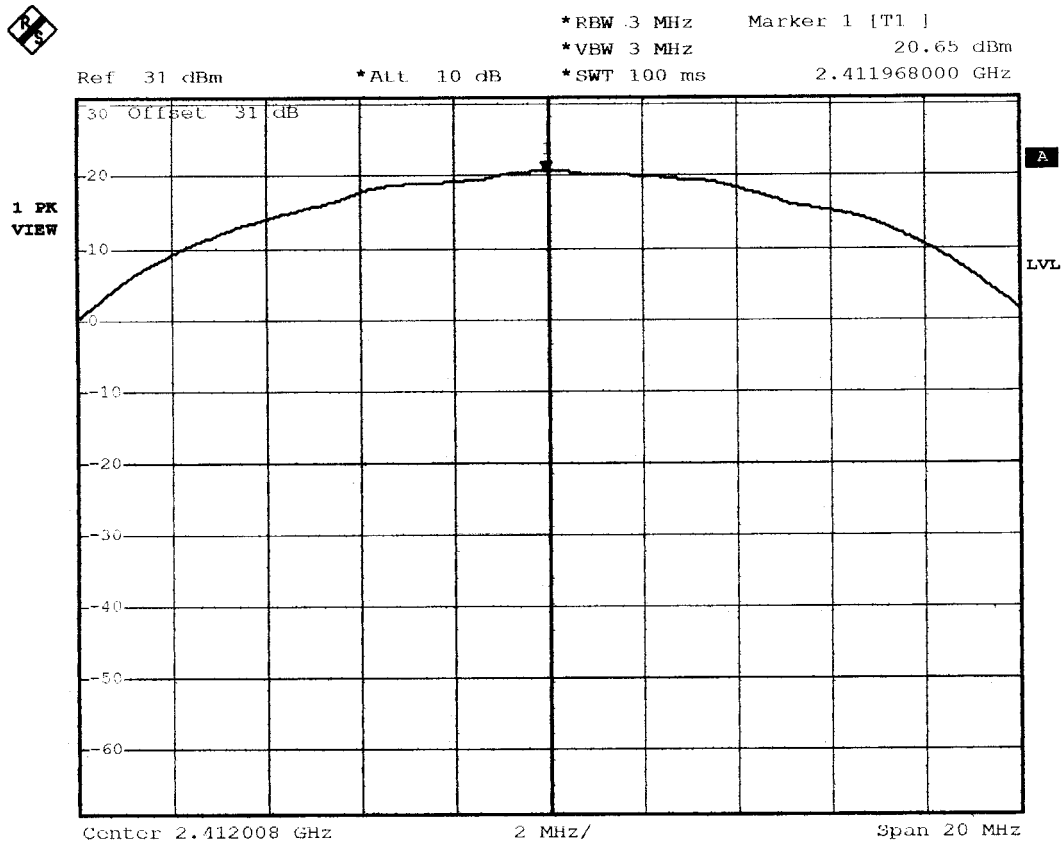

Date: 2.DEC.2002 10:12:01



Spectrum Research & Testing Lab., Inc.
No. 101-10, Ling 8,
Shan-Tong Li, Chung-Li
City, Taoyuan, Taiwan,
R.O.C.

TEST REPORT

Reference No.:A03031104
Report No.:FCCA02120305-01
FCC ID: PKW-WSB24-2
Page:38 of 67
Date:Mar. 11, 2003

CH6:

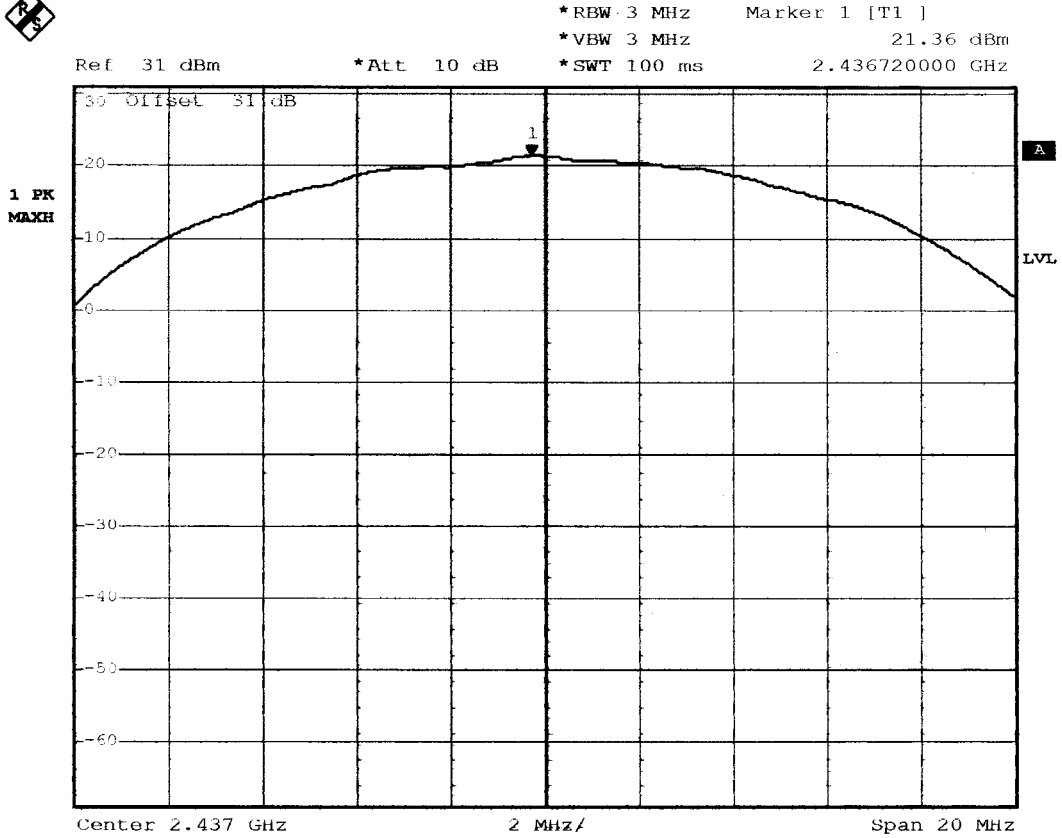

Date: 2.DEC.2002 09:56:35



Spectrum Research & Testing Lab., Inc.
No. 101-10, Ling 8,
Shan-Tong Li, Chung-Li
City, Taoyuan, Taiwan,
R.O.C.

TEST REPORT

Reference No.:A03031104
Report No.:FCCA02120305-01
FCC ID: PKW-WSB24-2
Page:39 of 67
Date:Mar. 11, 2003

CH11:

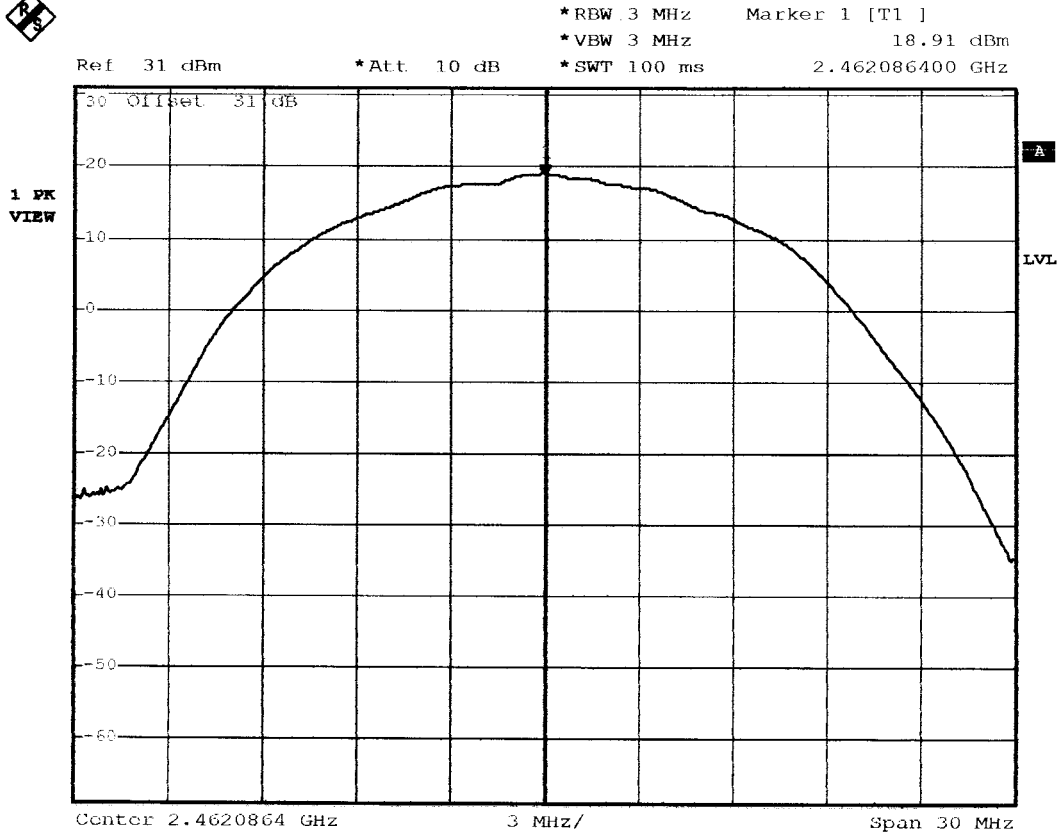

Date: 2.DEC.2002 10:41:43



4.5 BAND EDGE TEST

4.5.1 LIMIT

FCC Part15, Subpart C Section 15.247. In any 100 kHz bandwidth outside the frequency band in which the spread spectrum intentional radiator is operating, the radio frequency power that is produced by the intentional radiator shall be at least 20 dB below that in the 100 kHz bandwidth within the band that contains the highest level of the desired power, based on either an RF conducted or a radiated measurement. Attenuation below the general limits specified in Section 15.209(a) is not required. In addition, radiated emissions which fall in the restricted bands, as defined in Section 15.205(a), must also comply with the radiated emission limits specified in Section 15.209(a) (see Section 15.205(c)).

OPERATING FREQUENCY RANGE (MHz)	SPURIOUS EMISSION FREQUENCY (MHz)	LIMIT	
		Peak power ration to emission(dBc)	Emission level(dBuV/m)
902-928	<902	>20	NA
	>928	>20	NA
	960-1240	NA	54
2400-2483.5	<2400	>20	NA
	>2483.5-2500	NA	54
5725-5850	<5350-5460	NA	54
	<5725	>20	NA
	>5850	>20	NA



Spectrum Research & Testing Lab., Inc.
No. 101-10, Ling 8,
Shan-Tong Li, Chung-Li
City, Taoyuan, Taiwan,
R.O.C.

TEST REPORT

Reference No.:A03031104
Report No.:FCCA02120305-01
FCC ID: PKW-WSB24-2
Page:41 of 67
Date:Mar. 11, 2003

4.5.2 TEST EQUIPMENT

The following test equipment was used during the test:

EQUIPMENT/ FACILITIES	SPECIFICATIONS	MANUFACTURER	MODEL#/ SERIAL#	DUE DATE OF CAL. & CAL. CENTER
SPECTRUM	9kHz-7GHz	ROHDE & SCHWARZ	FSP7/ 839511/010	MAR. 2003 R & S
SPECTRUM	9KHz-26.5GHz	HP	8953E/ 3710A03220	MAY 2003 ETC
PRE-AMPLIFIER	1GHz-26.5GHz Gain:30dB	HP	8449B/ 3008A01019	NOV. 2002 ETC
HORN ANTENNA	1GHz TO 18GHz	EMCO	3115/ 9602-4681	DEC. 2002 ETC
OATS	3 - 10 M measurement	SRT	SRT-1	MAY 2003

NOTE: The calibration interval of the above test equipment is one year and the calibrations are traceable to NML/ROC and NIST/USA.



4.5.3 TEST SET-UP

FOR RF CONDUCTED TEST (dBc)

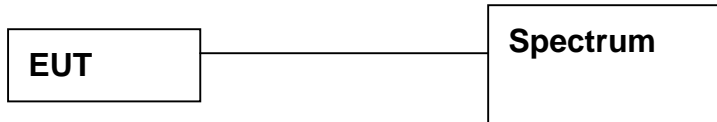

The EUT was connected to the spectrum through a 50 Ohm RF cable.

FOR RADIATED EMISSION TEST

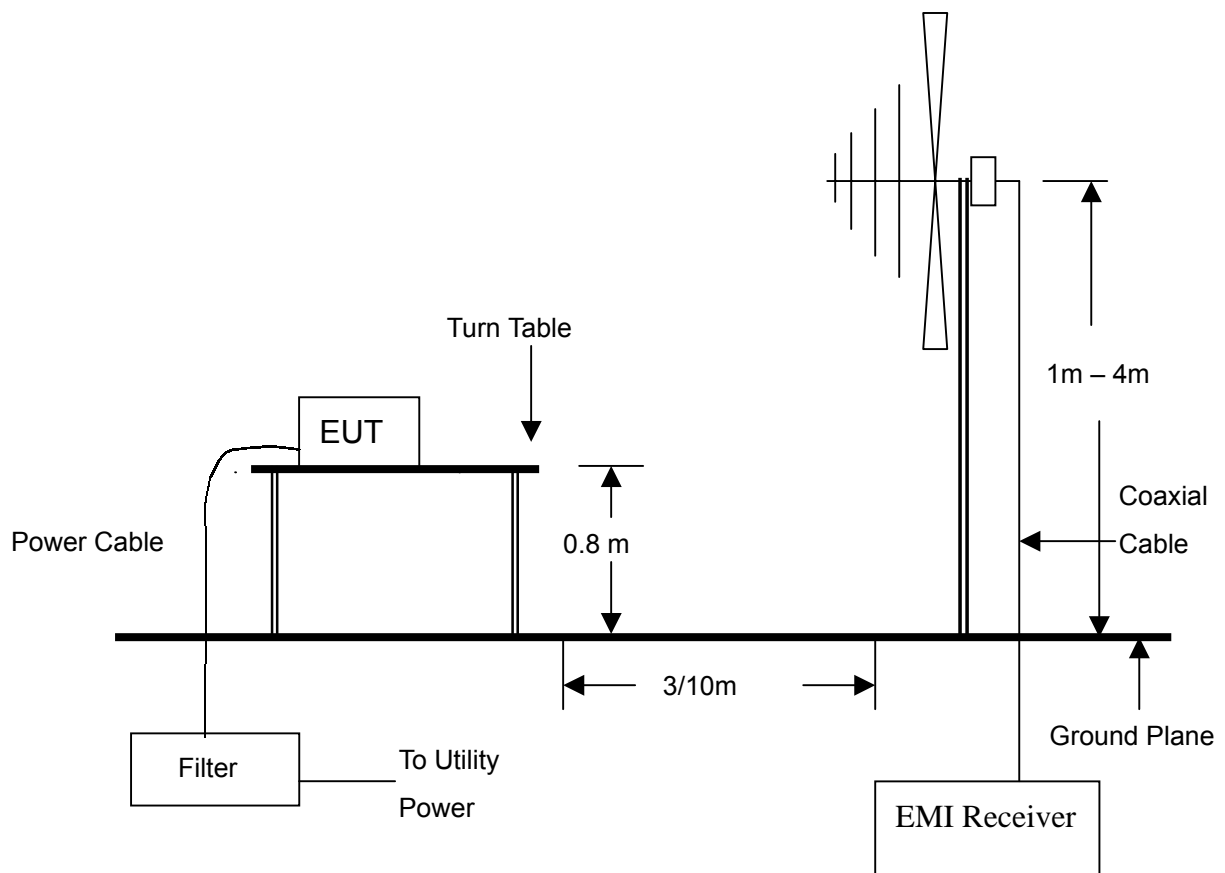

NOTE :

1. The EUT system was put on a wooden table with 0.8m heights above a ground plane.
2. For the actual test configuration, please refer to the photos of testing.



**Spectrum Research &
Testing Lab., Inc.**
No. 101-10, Ling 8,
Shan-Tong Li, Chung-Li
City, Taoyuan, Taiwan,
R.O.C.

TEST REPORT

Reference No.:A03031104
Report No.:FCCA02120305-01
FCC ID: PKW-WSB24-2
Page:43 of 67
Date:Mar. 11, 2003

4.5.4 TEST PROCEDURE

1. The EUT was operating in transmitter mode and could be controlled its channel.
Printed out the test result from the spectrum by hard copy function.
2. The EUT was tested according to the requirement of ANSI C63.4 and CISPR 22.
The measurements were made at an open area test site with 10 meter measurement distance under 1 GHz and with 3m distance above 1GHz. The frequency spectrum measured started from 30 MHz. Under 1 GHz. All readings were quasi-peak values with 120 kHz resolution bandwidth of the test receiver. Above 1 GHz, the measurements were made at an open area test site with 3 meter measurement distance and all readings were peak and average values with 1 MHz resolution bandwidth of the test receiver. The EUT system was operated in all typical methods by users. The cables connected to EUT and support units were moved to find the maximum emission levels for each frequency.

4.5.5 EUT OPERATING CONDITION

Same as section 4.1.5 of this report.



Spectrum Research & Testing Lab., Inc.
No. 101-10, Ling 8,
Shan-Tong Li, Chung-Li
City, Taoyuan, Taiwan,
R.O.C.

TEST REPORT

Reference No.:A03031104
Report No.:FCCA02120305-01
FCC ID: PKW-WSB24-2
Page:44 of 67
Date:Mar. 11, 2003

4.5.6 TEST RESULT

Temperature: 23°C Humidity: 65%RH
Spectrum Detector: PK. & AV. Tested by: James Lee
Test Result: Pass Configuration : 1

1. Conducted test

Frequency (MHz)	PEAK POWER OUTPUT (dBm)	Emission read Value(dBm)	Result of Band edge (dBc)	Band edge LIMIT (dBc)
<2400	7.64	-25.45	33.09	>20dBc
>2483.5	4.52	-39.47	43.99	>20dBc

2. Radiated emission test

Frequency (MHz)	Antenna polarization (H/V)	PEAK POWER OUTPUT (dBuV/m)	Emission read Value(dBuV/m)	Band edge LIMIT (dBuV/m)
<2400	V	108.1	44.6	54
>2483.5	V	105.2	43.5	54



Spectrum Research & Testing Lab., Inc.
 No. 101-10, Ling 8,
 Shan-Tong Li, Chung-Li
 City, Taoyuan, Taiwan,
 R.O.C.

TEST REPORT

Reference No.:A03031104
 Report No.:FCCA02120305-01
 FCC ID: PKW-WSB24-2
 Page:45 of 67
 Date:Mar. 11, 2003

<2400MHz:

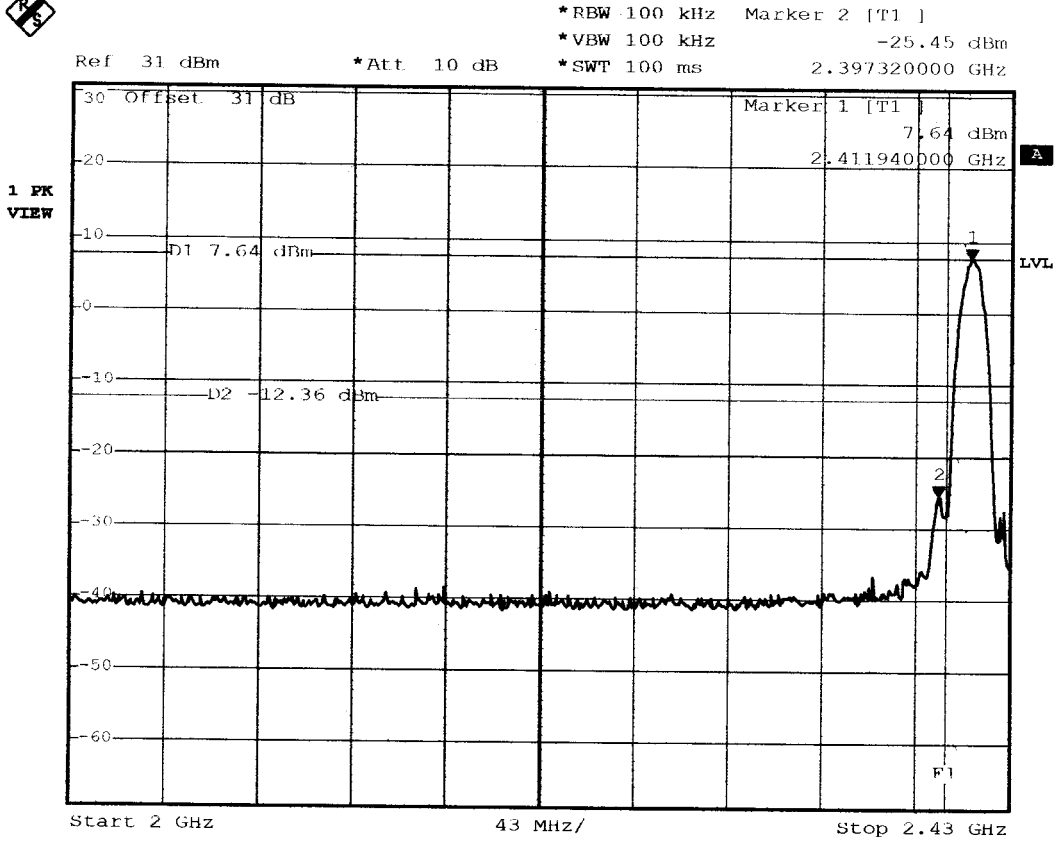

Date: 4.DEC.2002 09:58:35



Spectrum Research & Testing Lab., Inc.
 No. 101-10, Ling 8,
 Shan-Tong Li, Chung-Li
 City, Taoyuan, Taiwan,
 R.O.C.

TEST REPORT

Reference No.:A03031104
 Report No.:FCCA02120305-01
 FCC ID: PKW-WSB24-2
 Page:46 of 67
 Date:Mar. 11, 2003

>2483.5MHz



*RBW 100 kHz Marker 2 [T1]
 *VBW 100 kHz -39.47 dBm
 *SWT 100 ms 2.863360000 GHz

Ref 31 dBm

*Att 10 dB

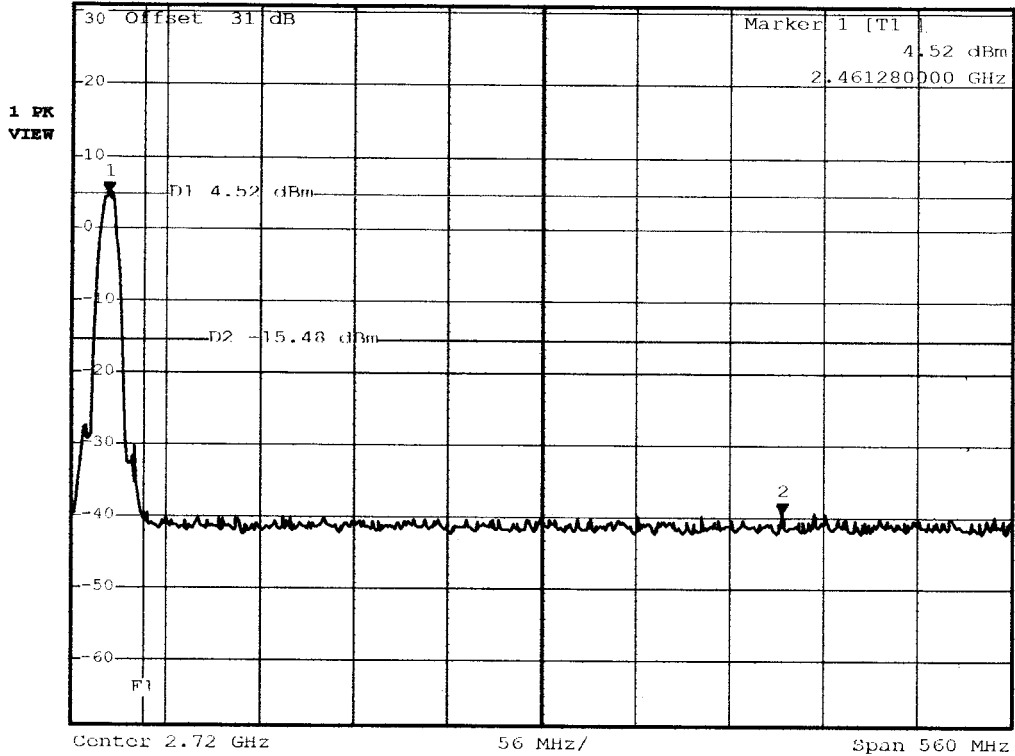

Date: 4.DEC.2002 10:07:33



Spectrum Research & Testing Lab., Inc.
No. 101-10, Ling 8,
Shan-Tong Li, Chung-Li
City, Taoyuan, Taiwan,
R.O.C.

TEST REPORT

Reference No.:A03031104
Report No.:FCCA02120305-01
FCC ID: PKW-WSB24-2
Page:47 of 67
Date:Mar. 11, 2003

4.5.6 TEST RESULT

Temperature: 23°C Humidity: 65%RH
Spectrum Detector: PK. & AV. Tested by: James Lee
Test Result: Pass Configuration : 2

1. Conducted test

Frequency (MHz)	PEAK POWER OUTPUT (dBm)	Emission read Value(dBm)	Result of Band edge (dBc)	Band edge LIMIT (dBc)
<2400	10.4	-28.58	38.98	>20dBc
>2483.5	8.9	-36.6	45.5	>20dBc

2. Radiated emission test

Frequency (MHz)	Antenna polarization (H/V)	PEAK POWER OUTPUT (dBuV/m)	Emission read Value(dBuV/m)	Band edge LIMIT (dBuV/m)
<2400	V	104.8	41.4	54
>2483.5	V	102.1	50.3	54



Spectrum Research & Testing Lab., Inc.
 No. 101-10, Ling 8,
 Shan-Tong Li, Chung-Li
 City, Taoyuan, Taiwan,
 R.O.C.

TEST REPORT

Reference No.:A03031104
 Report No.:FCCA02120305-01
 FCC ID: PKW-WSB24-2
 Page:48 of 67
 Date:Mar. 11, 2003

<2400MHz:



*REW 100 kHz Marker 2 [T1]
 *VBW 100 kHz -28.58 dBm
 *SWT 100 ms 2.399155104 GHz

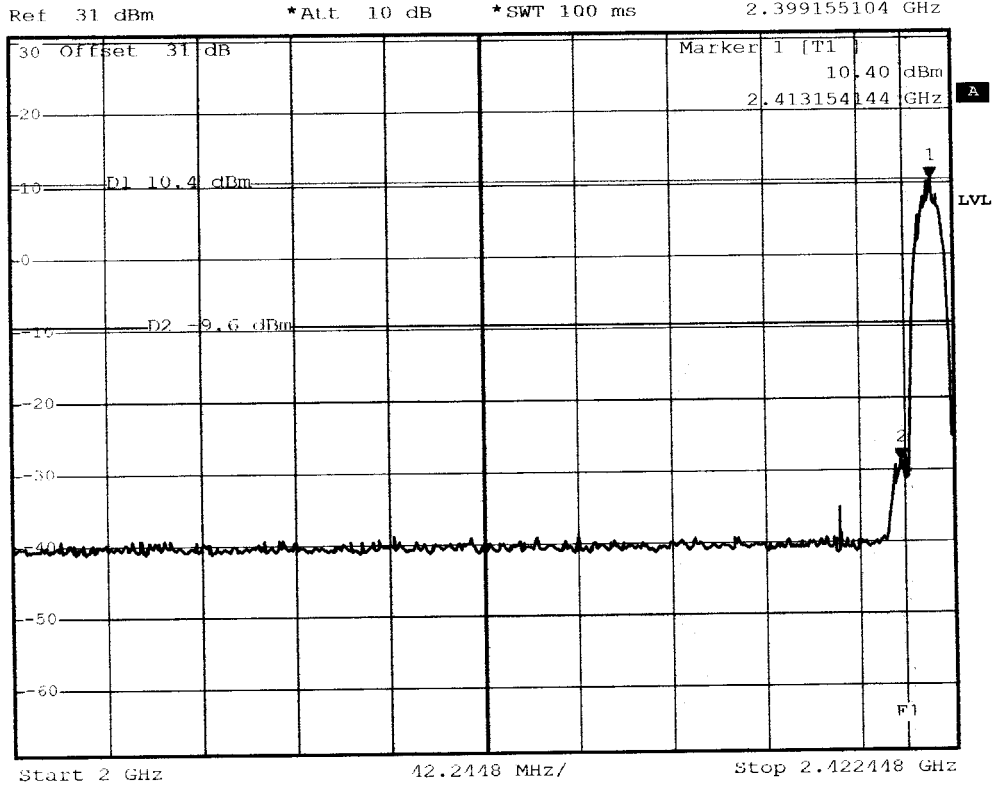

Date: 2.DEC.2002 10:26:53



Spectrum Research & Testing Lab., Inc.
 No. 101-10, Ling 8,
 Shan-Tong Li, Chung-Li
 City, Taoyuan, Taiwan,
 R.O.C.

TEST REPORT

Reference No.:A03031104
 Report No.:FCCA02120305-01
 FCC ID: PKW-WSB24-2
 Page:49 of 67
 Date:Mar. 11, 2003

>2483.5MHz



*RBW 100 kHz Marker 2 [T1]
 *VBW 100 kHz -36.60 dBm
 *SWT 100 ms 2.520400000 GHz

Ref 31 dBm

*Att 10 dB

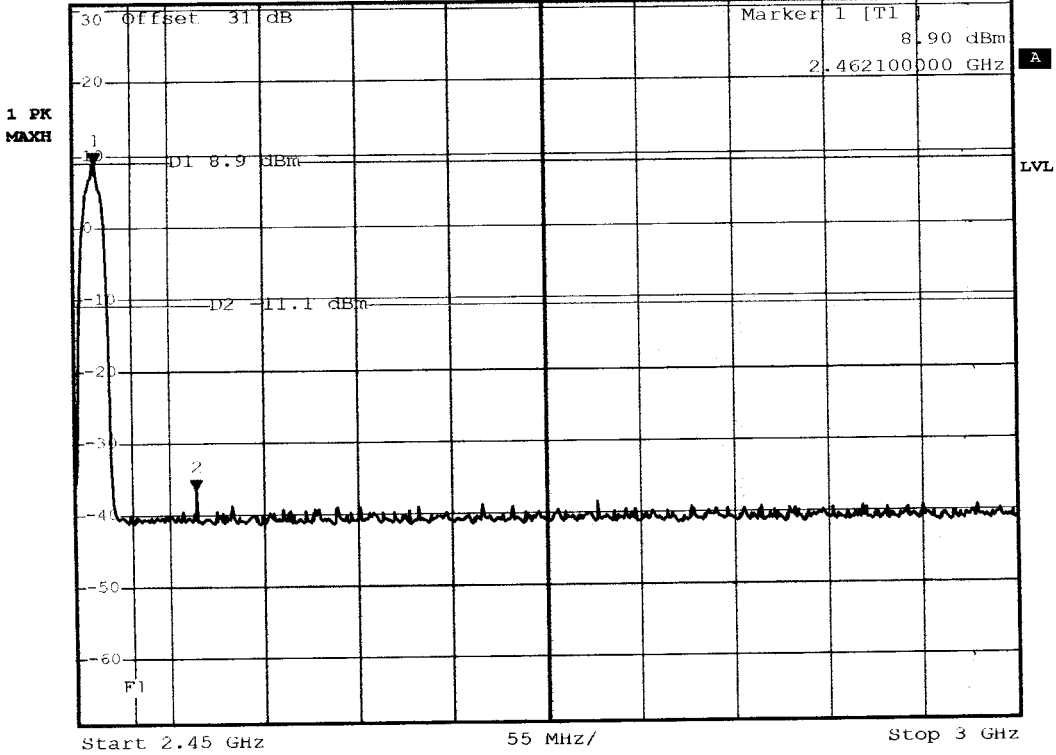

Date: 2.DEC.2002 10:30:42



Spectrum Research & Testing Lab., Inc.
 No. 101-10, Ling 8,
 Shan-Tong Li, Chung-Li
 City, Taoyuan, Taiwan,
 R.O.C.

TEST REPORT

Reference No.:A03031104
 Report No.:FCCA02120305-01
 FCC ID: PKW-WSB24-2
 Page:50 of 67
 Date:Mar. 11, 2003

4.6 POWER DENSITY TEST

4.6.1 LIMIT

FCC Part15, Subpart C Section 15.247.

FREQUENCY RANGE (MHz)	Limit(dBm/kHz)
902-928	8dBm/3kHz
2400-2483.5	
5725-5850	

4.6.2 TEST EQUIPMENT

The following test equipment was used during the radiated emission test:

EQUIPMENT/FACILITIES	SPECIFICATIONS	MANUFACTURER	MODEL#/SERIAL#	DUE DATE OF CAL. & CAL. CENTER
SPECTRUM	9kHz-7GHz	ROHDE & SCHWARZ	FSP7/ 839511/010	MAR. 2003 R & S

NOTE: The calibration interval of the above test equipment is one year and the calibrations are traceable to NML/ROC and NIST/USA.

4.6.3 TEST SET-UP

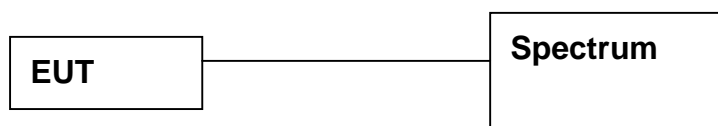

The EUT was connected to a spectrum through a 50 Ohm RF cable.

4.6.4 TEST PROCEDURE

The EUT was operating in transmitter mode and could be controlled its channel. Printed out the test result from the spectrum by hard copy function.

4.6.5 EUT OPERATING CONDITION

Same as section 4.1.5 of this report.



Spectrum Research & Testing Lab., Inc.
 No. 101-10, Ling 8,
 Shan-Tong Li, Chung-Li
 City, Taoyuan, Taiwan,
 R.O.C.

TEST REPORT

Reference No.:A03031104
 Report No.:FCCA02120305-01
 FCC ID: PKW-WSB24-2
 Page:51 of 67
 Date:Mar. 11, 2003

4.6.6 TEST RESULT

Temperature:	<u>23°C</u>	Humidity:	<u>65%RH</u>
Spectrum Detector:	<u>PK.</u>	Tested by:	<u>James Lee</u>
Test Result	<u>Pass</u>	Configuration :	<u>1</u>

CHANNEL NUMBER	CHANNEL FREQUENCY (MHz)	RF POWER LEVEL IN 3kHz BW (dBm/3kHz)	MAXIMUM LIMIT (dBm/3kHz)
1	2409.9594	-6.27	8
6	2434.9580	-7.32	8
11	2460.9372	-8.22	8

CH1:

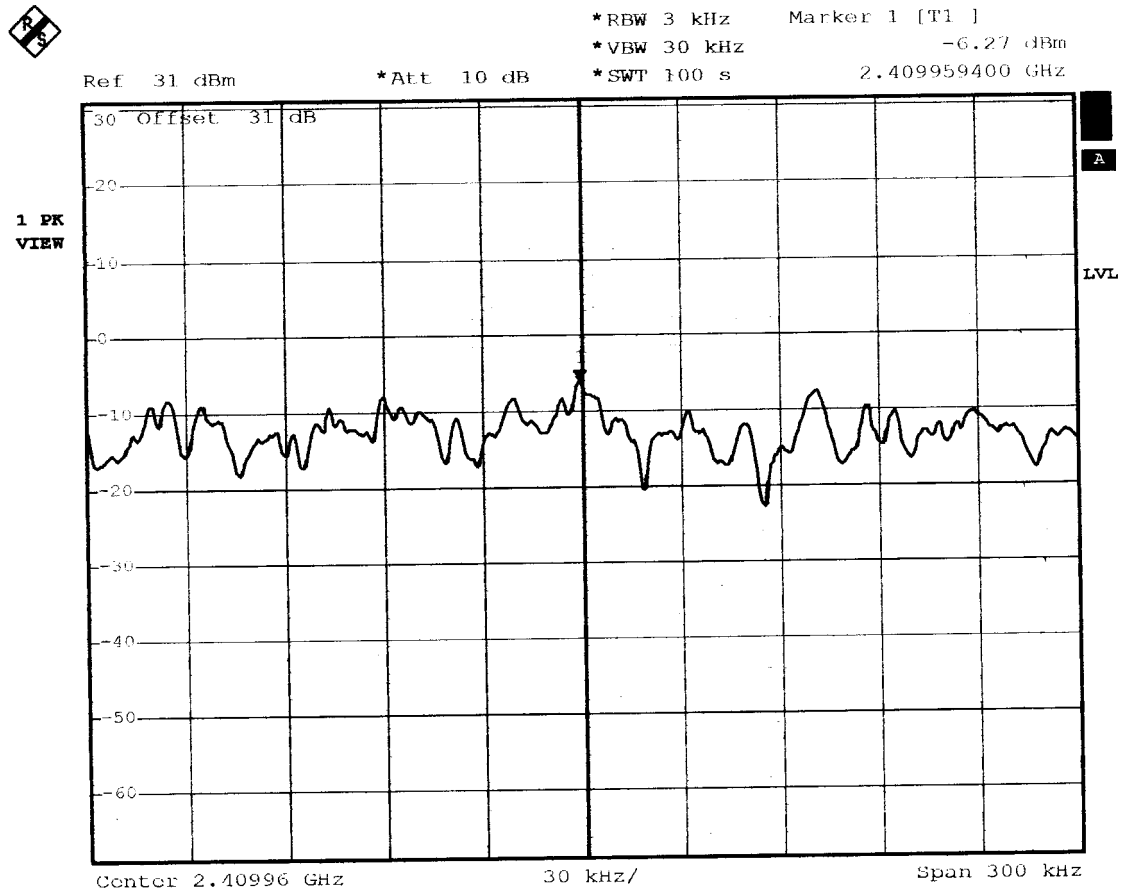

Date: 2.DEC.2002 16:11:23



Spectrum Research & Testing Lab., Inc.
No. 101-10, Ling 8,
Shan-Tong Li, Chung-Li
City, Taoyuan, Taiwan,
R.O.C.

TEST REPORT

Reference No.:A03031104
Report No.:FCCA02120305-01
FCC ID: PKW-WSB24-2
Page:52 of 67
Date:Mar. 11, 2003

CH6:

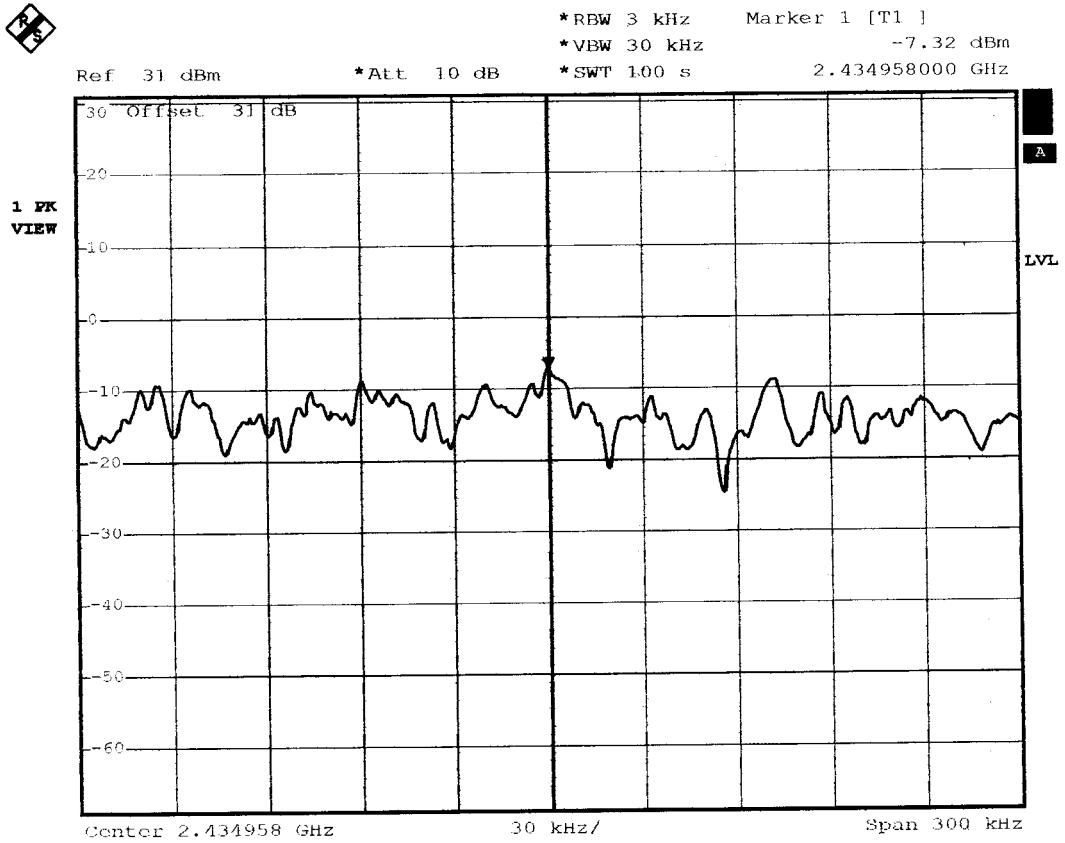

Date: 2.DEC.2002 16:31:39



Spectrum Research & Testing Lab., Inc.
No. 101-10, Ling 8,
Shan-Tong Li, Chung-Li
City, Taoyuan, Taiwan,
R.O.C.

TEST REPORT

Reference No.:A03031104
Report No.:FCCA02120305-01
FCC ID: PKW-WSB24-2
Page:53 of 67
Date:Mar. 11, 2003

CH11:

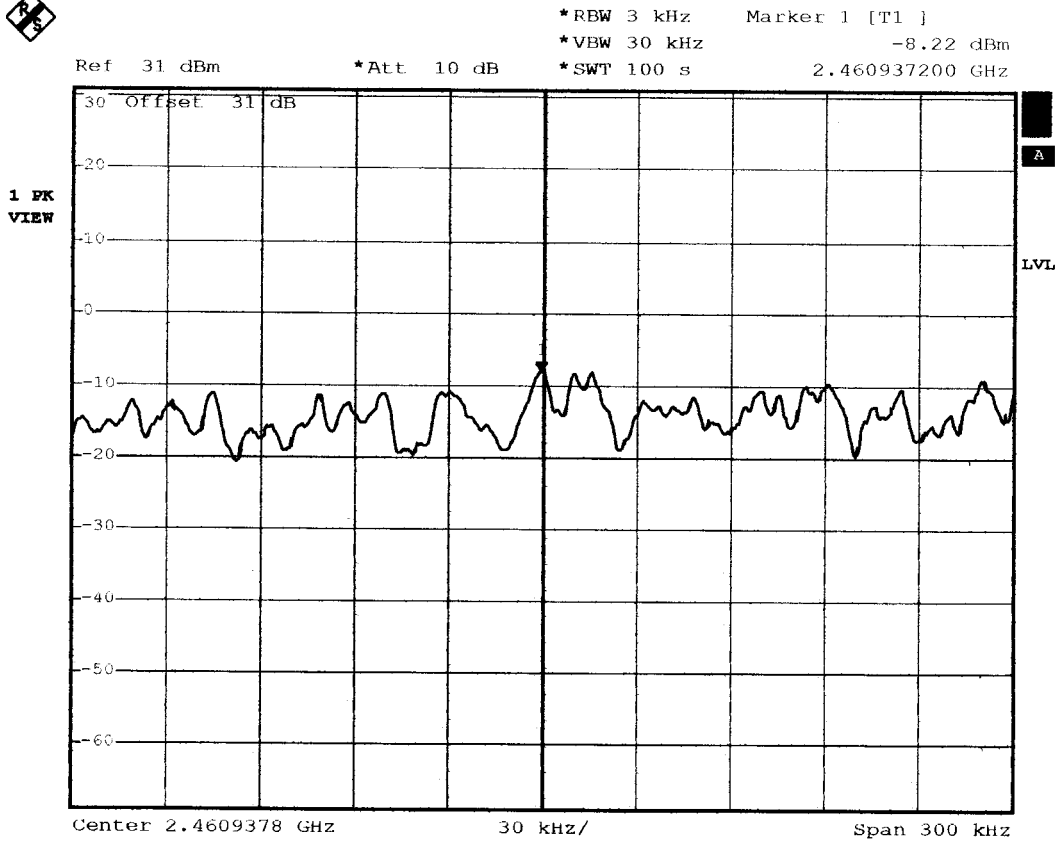

Date: 2.DEC.2002 16:53:01



Spectrum Research & Testing Lab., Inc.
No. 101-10, Ling 8,
Shan-Tong Li, Chung-Li
City, Taoyuan, Taiwan,
R.O.C.

TEST REPORT

Reference No.:A03031104
Report No.:FCCA02120305-01
FCC ID: PKW-WSB24-2
Page:54 of 67
Date:Mar. 11, 2003

Temperature: 23°C Humidity: 65%RH
Spectrum Detector: PK. Tested by: James Lee
Test Result: Pass Configuration : 2

CHANNEL NUMBER	CHANNEL FREQUENCY (MHz)	RF POWER LEVEL IN 3KHz BW (dBm/3kHz)	MAXIMUM LIMIT (dBm/3kHz)
1	2411.3086	-2.40	8
6	2436.0940	-2.07	8
11	2461.307	-4.82	8



Spectrum Research & Testing Lab., Inc.
 No. 101-10, Ling 8,
 Shan-Tong Li, Chung-Li
 City, Taoyuan, Taiwan,
 R.O.C.

TEST REPORT

Reference No.:A03031104
 Report No.:FCCA02120305-01
 FCC ID: PKW-WSB24-2
 Page:55 of 67
 Date:Mar. 11, 2003

CH1:

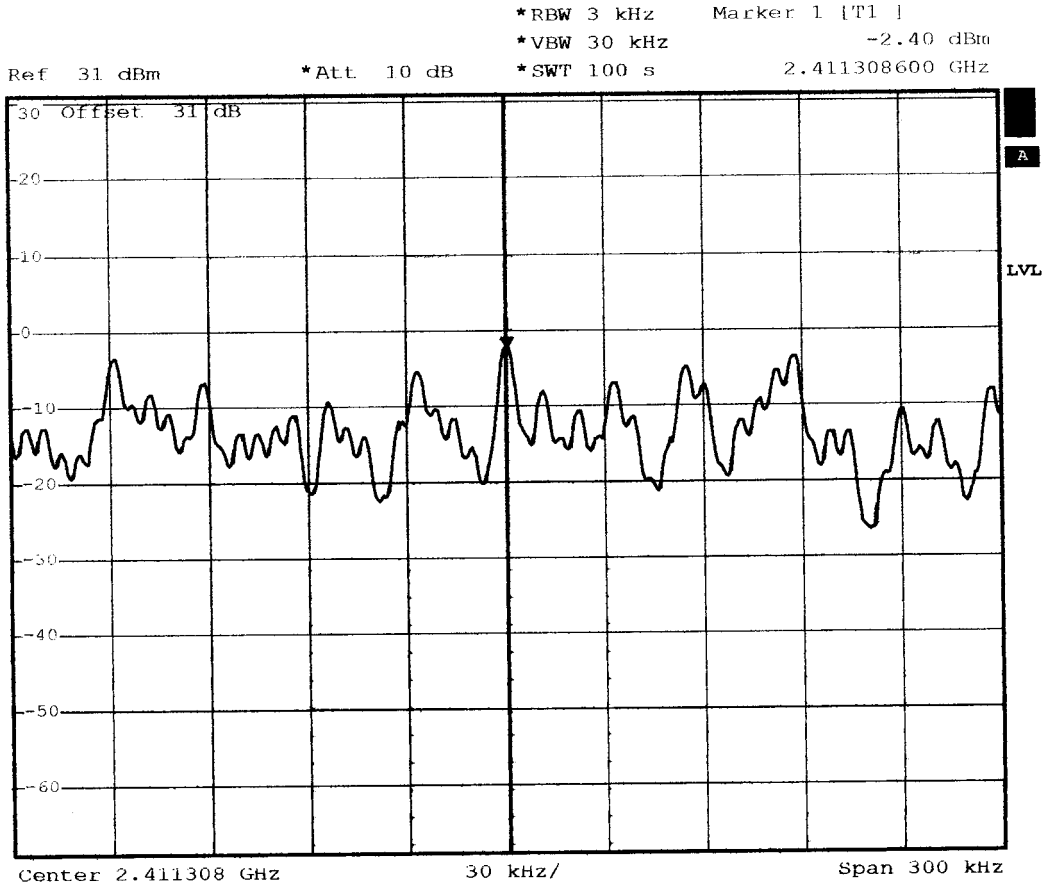

Date: 2.DEC.2002 10:08:32



Spectrum Research & Testing Lab., Inc.
No. 101-10, Ling 8,
Shan-Tong Li, Chung-Li
City, Taoyuan, Taiwan,
R.O.C.

TEST REPORT

Reference No.:A03031104
Report No.:FCCA02120305-01
FCC ID: PKW-WSB24-2
Page:56 of 67
Date:Mar. 11, 2003

CH6:

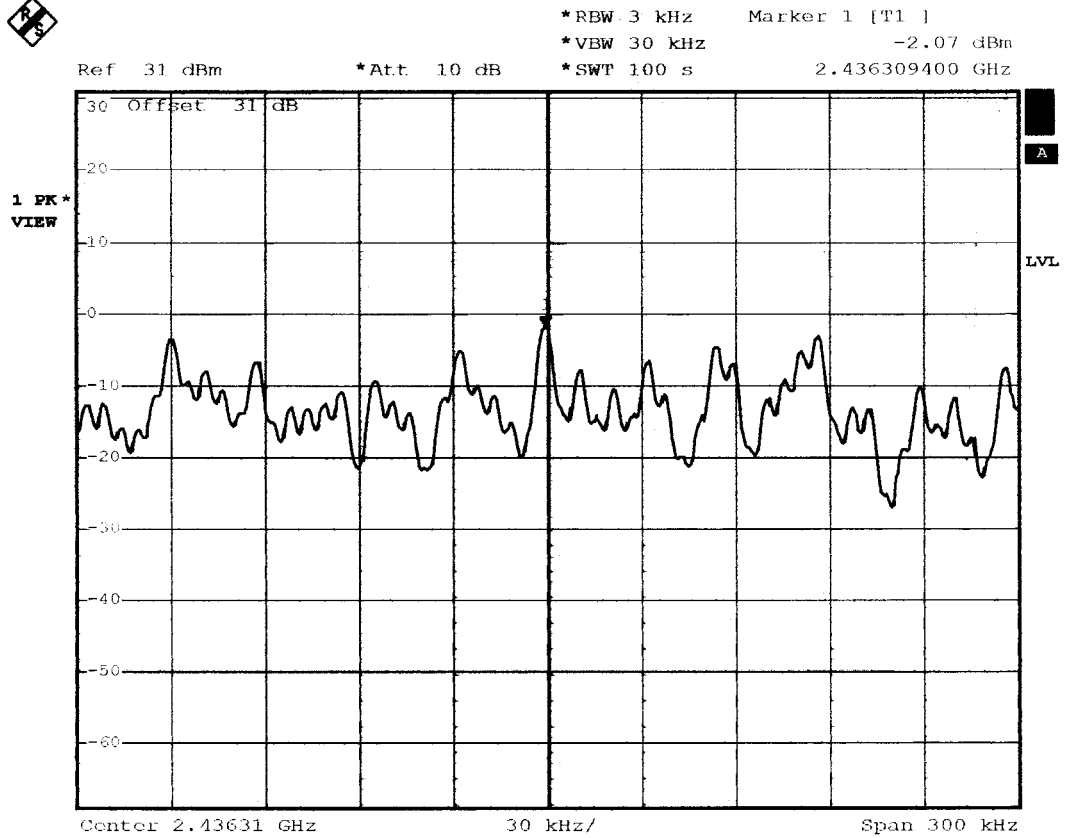

Date: 2.DEC.2002 10:02:19



Spectrum Research & Testing Lab., Inc.
 No. 101-10, Ling 8,
 Shan-Tong Li, Chung-Li
 City, Taoyuan, Taiwan,
 R.O.C.

TEST REPORT

Reference No.:A03031104
 Report No.:FCCA02120305-01
 FCC ID: PKW-WSB24-2
 Page:57 of 67
 Date:Mar. 11, 2003

CH11:

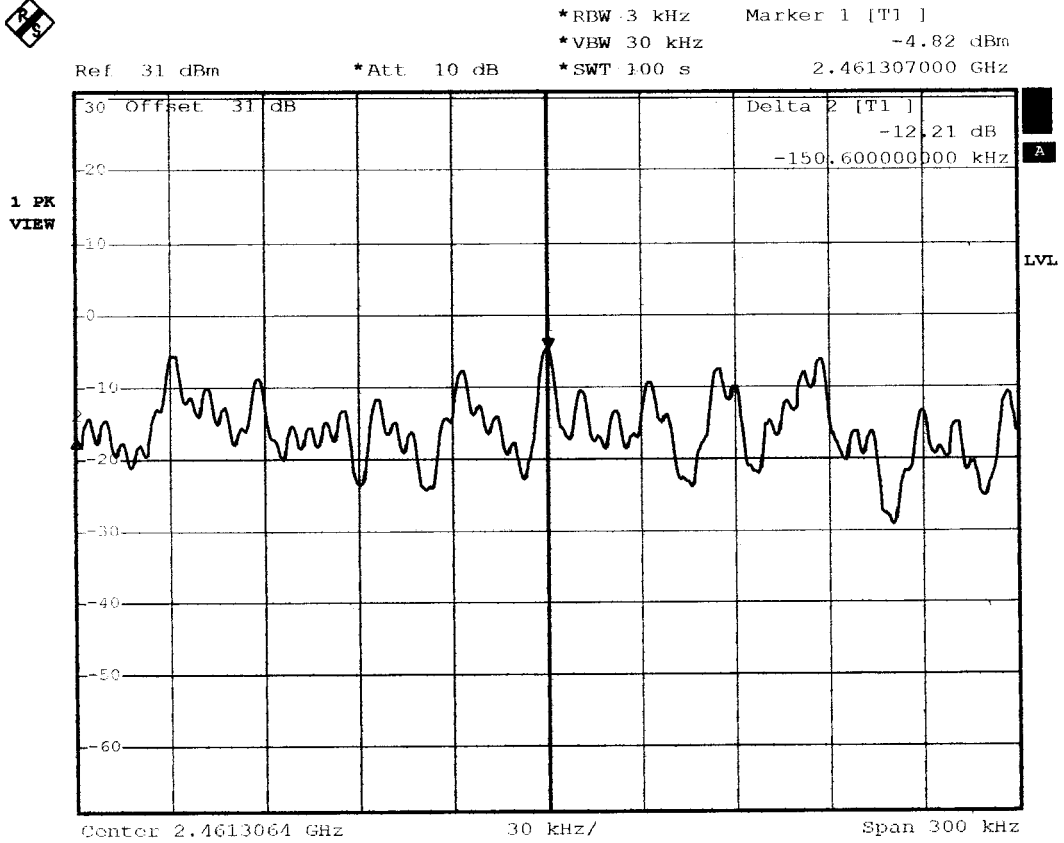

Date: 2.DEC.2002 10:38:59



4.7 RF POWER EXPOSURE EVALUATION TEST

4.7.1 LIMIT

According to the requirement of IEEE C95.1 and FCC OET Bulletin 65.

Limits for Occupational/Controlled Exposure

Frequency Range (MHz)	Electric Field Strength(E) (V/m)	Magnetic Field Strength(H) (A/m)	Power density (S) (mW/cm ²)	Averaging Time E ² , H ² or S (minutes)
0.3-3.0	614	1.63	(100)*	6
3.0-30	1842/f	4.89/f	(900/f ²)*	6
30-300	61.4	0.163	1.0	6
300-1500	--	--	f/300	6
1500-100,000	--	--	5	6

Limits for General Population/Uncontrolled Exposure

Frequency Range (MHz)	Electric Field Strength(E) (V/m)	Magnetic Field Strength(H) (A/m)	Power density (S) (mW/cm ²)	Averaging Time E ² , H ² or S (minutes)
0.3-1.34	614	1.63	(100)*	30
1.34-30	824/f	2.19/f	(180/f ²)*	30
30-300	27.5	0.073	0.2	30
300-1500	--	--	f/1500	30
1500-100,000	--	--	1.0	30

f = frequency in MHz *Plane-wave equivalent power density

NOTE 1: Occupational/controlled limits apply in situations in which persons are exposed as a consequence of their employment provided those persons are fully aware of the potential for exposure and can exercise control over their exposure. Limits for occupational/controlled exposure also apply in situations when an individual is transient through a location where occupational/controlled limits apply provided he or she is made aware of the potential for exposure.

NOTE 2: General population/uncontrolled exposures apply in situations in which the general public may be exposed, or in which persons that are exposed as a consequence of their employment may not be fully aware of the potential for exposure or cannot exercise control over their exposure.

 Spectrum Research & Testing Lab., Inc. No. 101-10, Ling 8, Shan-Tong Li, Chung-Li City, Taoyuan, Taiwan, R.O.C.	<h1>TEST REPORT</h1>	Reference No.:A03031104 Report No.:FCCA02120305-01 FCC ID: PKW-WSB24-2 Page:59 of 67 Date:Mar. 11, 2003
--	----------------------	---

4.7.2 TEST EQUIPMENT

The following test equipment was used during the test:

EQUIPMENT/ FACILITIES	SPECIFICATIONS	MANUFACTURER	MODEL#/ SERIAL#	DUE DATE OF CAL. & CAL. CENTER
SPECTRUM	9kHz-7GHz	ROHDE & SCHWARZ	FSP7/ 839511/010	MAR. 2003 R & S
POWER METER	N/A	HP	435A/ 1810A08277	NOV. 2002 ETC
POWER SENSOR	DC-18GHz 0.3 μ W-100mW 50	HP	8481A	NOV. 2002 ETC

NOTE: The calibration interval of the above test equipment is one year and the calibrations are traceable to NML/ROC and NIST/USA.

4.7.3 TEST SET-UP

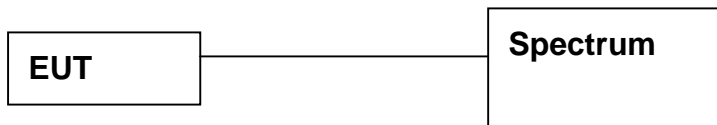

The EUT was connected to the spectrum through a 50 Ω RF cable.



4.7.4 TEST PROCEDURE

1. The EUT was operating in transmitter mode and could be controlled its channel. The power meter read power value.
2. The EUT uses an sleeve diploe antenna and the antenna gain is 2dBi declared by manufacturer.
3. As discussed in OET Bulletin 65, calculations can be made to predict RF field strength and power density levels around typical RF sources. For example, in the case of a non-directional antenna, a prediction for power density in the far-field of the antenna can be made by use of the general Equations (1) or (2) below [for conversion to electric or magnetic field strength see Equation (3) above]. These equations are generally accurate in the far-field of an antenna but will over-predict power density in the near field, where it could be used for making a " worst case" or conservative prediction.

$$S=PG/4 R^2 \quad (\text{Eq.1})$$

$$S=EIRP/4 R^2 \quad (\text{Eq. 2})$$

$$S=E^2/3770=37.7H^2 \quad (\text{Eq. 3})$$

where: S = power density (mW/cm²)

E = electric field strength (V/m)

H = magnetic field strength (A/m)

S = power density (in appropriate units, e.g. mW/cm²)

P = power input to the antenna (in appropriate units, e.g., mW)

G = power gain of the antenna in the direction of interest relative to an isotropic radiator (dBi)

R = distance to the center of radiation of the antenna (appropriate units, e.g., cm)

where: EIRP = equivalent (or effective) isotropically radiated power

4.7.5 EUT OPERATING CONDITION

Same as section 4.1.5 of this report.



Spectrum Research & Testing Lab., Inc.
No. 101-10, Ling 8,
Shan-Tong Li, Chung-Li
City, Taoyuan, Taiwan,
R.O.C.

TEST REPORT

Reference No.:A03031104
Report No.:FCCA02120305-01
FCC ID: PKW-WSB24-2
Page:61 of 67
Date:Mar. 11, 2003

4.7.6 RESULT

Temperature: 23°C Humidity: 65%RH
Spectrum Detector: PK. Tested by: James Lee
Result: Pass Configuration : 1

CHANNEL NUMBER	CHANNEL FREQUENCY (MHz)	RF Output Power to antenna (dBm)(e.i.r.p.)	Result calculated when nearby person (cm)	Limit when nearby person (cm)
1	2412	21.66	3.42	20
6	2437	20.57	3.01	20
11	2462	19.9	2.79	20

Temperature: 25°C Humidity: 60%RH
Spectrum Detector: PK. Tested by: James Lee
Result: Pass Configuration : 2

CHANNEL NUMBER	CHANNEL FREQUENCY (MHz)	RF Output Power to antenna (dBm)(e.i.r.p.)	Result calculated when nearby person (cm)	Limit when nearby person (cm)
1	2412	22.5	3.76	20
6	2437	22.8	3.89	20
11	2462	20.7	3.06	20



**Spectrum Research &
Testing Lab., Inc.**
No. 101-10, Ling 8,
Shan-Tong Li, Chung-Li
City, Taoyuan, Taiwan,
R.O.C.

TEST REPORT

Reference No.:A03031104
Report No.:FCCA02120305-01
FCC ID: PKW-WSB24-2
Page:62 of 67
Date:Mar. 11, 2003

5. Antenna application

5.1 Antenna requirement

The EUT's antenna is met the requirement of FCC part15C section15.203 and 15.204.

FCC part15C section15.247 requirement:

Systems operating in the 2400-2483.5 MHz band that are used exclusively for fixed, point-to-point operations may employ transmitting antennas with directional gain greater than 6 dBi provided the maximum peak output power of the intentional radiator is reduced by 1 dB for every 3 dB that the directional gain of the antenna exceeds 6 dBi.

5.2 Result

The EUT's antenna used a sleeve dipole antenna. The antenna's gain is 2dBi and meets the requirement.



6. PHOTOS OF TESTING

- Conducted test (Wireless AP)





Spectrum Research & Testing Lab., Inc.
No. 101-10, Ling 8,
Shan-Tong Li, Chung-Li
City, Taoyuan, Taiwan,
R.O.C.

TEST REPORT

Reference No.:A03031104
Report No.:FCCA02120305-01
FCC ID: PKW-WSB24-2
Page:64 of 67
Date:Mar. 11, 2003

- Conducted test(Wireless Router)





Spectrum Research & Testing Lab., Inc.
No. 101-10, Ling 8,
Shan-Tong Li, Chung-Li
City, Taoyuan, Taiwan,
R.O.C.

TEST REPORT

Reference No.:A03031104
Report No.:FCCA02120305-01
FCC ID: PKW-WSB24-2
Page:65 of 67
Date:Mar. 11, 2003

- Radiated test(Wireless AP)

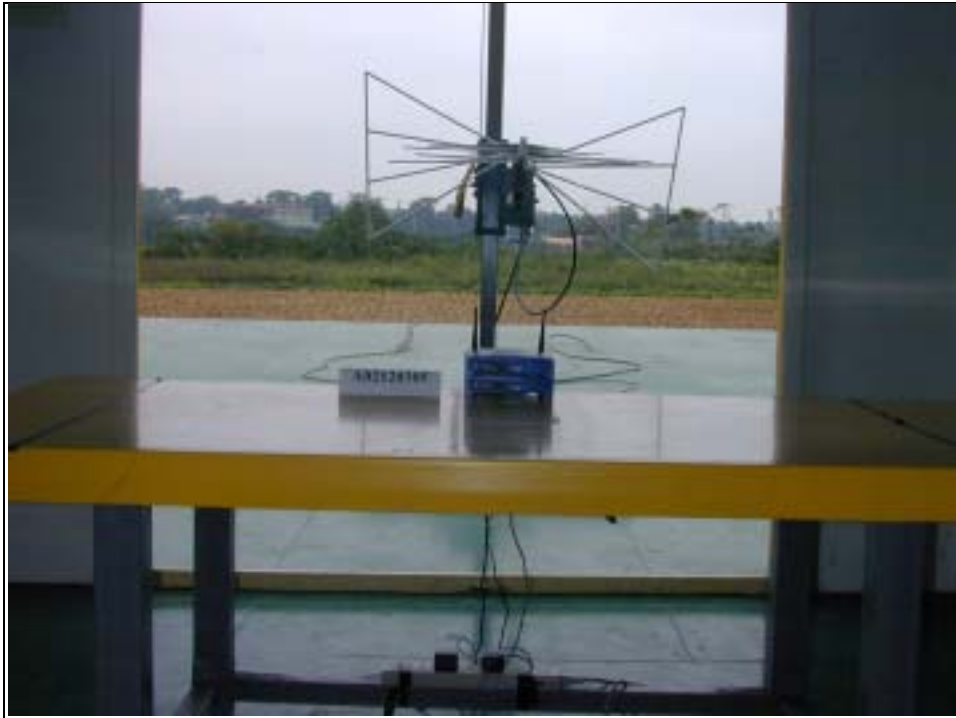



Spectrum Research & Testing Lab., Inc.
No. 101-10, Ling 8,
Shan-Tong Li, Chung-Li
City, Taoyuan, Taiwan,
R.O.C.

TEST REPORT

Reference No.:A03031104
Report No.:FCCA02120305-01
FCC ID: PKW-WSB24-2
Page:66 of 67
Date:Mar. 11, 2003

- Radiated test(Wireless Router)





Spectrum Research & Testing Lab., Inc.
No. 101-10, Ling 8,
Shan-Tong Li, Chung-Li
City, Taoyuan, Taiwan,
R.O.C.

TEST REPORT

Reference No.:A03031104
Report No.:FCCA02120305-01
FCC ID: PKW-WSB24-2
Page:67 of 67
Date:Mar. 11, 2003

7. TERMS OF ABRIVATION

AV.	Average detection
AZ(°)	Turn table azimuth
Correct.	Correction
EL(m)	Antenna height (meter)
EUT	Equipment Under Test
Horiz.	Horizontal direction
LISN	Line Impedance Stabilization Network
NSA	Normalized Site Attenuation
Q.P.	Quasi-peak detection
SRT Lab	Spectrum Research & Testing Laboratory, Inc.
Vert.	Vertical direction