



Spectrum Research & Testing Lab., Inc.

No. 101-10, Ling 8,
Shan-Tong Li, Chung-Li
City, Taoyuan, Taiwan

TEST REPORT

Reference No.:A02121801
Report No.:FCCA02121801
FCC ID:PKW-WSB24-1
Page:1 of 1
Date: Dec. 18, 2002

Product Name: Wireless Router with Signal Booster (SB)
Model Number: WSB24-1
Applicant: THE LINKSYS GROUP, INC.
17401 ARMSTRONG AVE., IRVINE, CA 92614, U.S.A.
Date of Receipt: Dec. 1, 2002
Finished date of Test: Dec. 4, 2002
Applicable Standards: 47 CFR Part 15, Subpart C
ANSI C63.4:1992

We, **Spectrum Research & Testing Laboratory Inc.**, hereby certify that one sample of the above was tested in our laboratory with positive results according to the above-mentioned standards. The records in the report are an accurate account of the results. Details of the results are given in the subsequent pages of this report.

Tested By : James Lee , Date: Dec. 05, 2002
(James Lee)

Checked By : Spring Wang , Date: Dec. 05, 2002
(Spring Wang)

Approved By : Harris W. Lai , Date: Dec. 05, 2002
(Harris W. Lai, Director)



Lab Code: 200099-0



TABLE OF CONTENTS

1. DOCUMENT POLICY AND TEST STATEMENT.....	4
1.1 DOCUMENT POLICY	4
1.2 TEST STATEMENT	4
2. DESCRIPTION OF EUT AND TEST MODE	4
2.1 GENERAL DESCRIPTION OF EUT.....	4
2.2 DESCRIPTION OF SUPPORT UNIT.....	5
2.3 DESCRIPTION OF TEST MODE	5
3. DESCRIPTION OF APPLIED STANDARDS	6
4. TECHNICAL CHARACTERISTICS TEST.....	7
4.1 CONDUCTED EMISSION TEST.....	7
4.1.1 LIMIT	7
4.1.2 TEST EQUIPMENT	7
4.1.3 TEST SETUP.....	8
4.1.4 TEST PROCEDURE	8
4.1.5 EUT OPERATING CONDITION	8
4.1.6 TEST RESULT	9
4.2 RADIATED EMISSION TEST	11
4.2.1 LIMIT	11
4.2.2 TEST EQUIPMENT	12
4.2.3 TEST SET-UP.....	13
4.2.4 TEST PROCEDURE	14
4.2.5 EUT OPERATING CONDITION	14
4.2.6 TEST RESULT	15
4.3 6DBC BANDWIDTH TEST.....	20
4.3.1 LIMIT	20
4.3.2 TEST EQUIPMENT	20
4.3.3 TEST SET-UP.....	20
4.3.5 EUT OPERATING CONDITION	20
4.3.6 TEST RESULT	21
4.4 PEAK POWER TEST	24
4.4.1 LIMIT	24
4.4.2 TEST EQUIPMENT	24
4.4.3 TEST SET-UP.....	25
4.4.5 EUT OPERATING CONDITION	25
4.4.6 TEST RESULT	26
4.5 BAND EDGE TEST	29
4.5.1 LIMIT	29
4.5.2 TEST EQUIPMENT	30
4.5.3 TEST SET-UP.....	31
4.5.5 EUT OPERATING CONDITION	32



Spectrum Research & Testing Lab., Inc.
No. 101-10, Ling 8,
Shan-Tong Li, Chung-Li
City, Taoyuan, Taiwan

TEST REPORT

Reference No.:A02120305
Report No.:FCCA02120305
FCC ID: PKW-WSB24-1
Page:3 of 3
Date:Dec.18, 2002

4.5.6 TEST RESULT	33
4.5.6 TEST RESULT	33
4.6 POWER DENSITY TEST	36
4.6.1 LIMIT	36
4.6.2 TEST EQUIPMENT	36
4.6.3 TEST SET-UP.....	36
4.6.5 EUT OPERATING CONDITION	36
4.6.6 TEST RESULT	37
4.7 RF POWER EXPOSURE EVALUATION TEST	41
4.7.1 LIMIT	41
4.7.2 TEST EQUIPMENT	42
4.7.3 TEST SET-UP.....	42
4.7.5 EUT OPERATING CONDITION	43
4.7.6 RESULT.....	44
5. ANTENNA APPLICATION	45
5.1 ANTENNA REQUIREMENT.....	45
5.2 RESULT.....	45
6. TERMS OF ABRIVATION	46



1. DOCUMENT POLICY AND TEST STATEMENT

1.1 DOCUMENT POLICY

- The report shall not be reproduced except in full, without the written approval of SRT Lab, Inc.

1.2 TEST STATEMENT

- The test results in the report apply only to the unit tested by SRT Lab.
- There was no deviation from the requirements of test standards during the test.
- AC power source, 120 VAC/60 Hz, was used during the test.

2. DESCRIPTION OF EUT AND TEST MODE

2.1 GENERAL DESCRIPTION OF EUT

PRODUCT	Wireless Router with Signal Booster (SB)
MODEL NO.	WSB24-1
POWER SUPPLY	(ROUTER) 5Vdc from adaptor; Brand : The Linksys, Model:MS15-050250-A1D, Rating:I/P:100-240Vac、 50-60Hz, O/P:5Vdc、 2.5A (SB) 5Vdc from adaptor; Brand : FAIRWAY, Model:WN10A-050, Rating:I/P:100-240Vac、 50-60Hz, O/P:5Vdc、 2A
CABLE	RF cable(reverse TNC to reverse SMA) x2
I/O PORT	Router: Reverse TNC x2, RJ45(WAN) x1, RJ45(LAN) x 5 SB: Reverse TNC x2, Reverse SMA x2,
FREQUENCY BAND	2400~2483.5MHz
CARRIER FREQUENCY	CH1: 2412MHz~CH11: 2462MHz
NUMBER OF CHANNEL	11
CHANNEL SPACING	5MHz
RATED RF OUTPUT POWER	120.2mW
I.F. & L.O.	I.F.: 374MHz, L.O.:2038~2088MHz
MODULATION TYPE	QPSK/BPSK/CCK
BIT RATE OF TRANSMISSION	11Mbps
ANTENNA TYPE	Sleeve dipole

NOTE : The EUT consists of a wireless router and a signal booster. For more detailed features, please refer to the manufacturer' s specification or User' s Manual of EUT.



2.2 DESCRIPTION OF SUPPORT UNIT

The transmitter part of EUT was tested with a PC system and configured by the requirement of ANSI C63.4. All interface ports were connected to the appropriate support units via specific cables. The support units and cables are listed below.

NO	DEVICE	BRAND	MODEL #	FCC ID / DOC	CABLE
1.	Notebook	DELL	PP01L/ 3F438A01	DOC	1.8m unshielded AC power cable 1.8m unshielded DC power cable
2	Notebook	ACER	MS2110/ 9143U0160C2100AC 7M000	DOC	1.8m unshielded AC power cable 1.8m unshielded DC power cable
3	Wireless LAN	LINKSYS	WPC11 v2.5	PKW-WPC11- V2	N/A

NOTE : For the actual test configuration, please refer to the photos of testing.

2.3 DESCRIPTION OF TEST MODE

11 channels are provided by EUT. The 3 channels of lower, medium and higher were chosen for test. There are three test mode for each test configuration as below:

Test mode	Frequency(MHz)
Ch.1	2412
Ch.6	2437
Ch.11	2462

NOTE :

1. Below 1 GHz, the channel 1, 6, and 11 were pre-tested in chamber. The channel 11, worst case one, was chosen for conducted and radiated emission test.
2. Above 1 GHz, the channel 1, 6 and 11 were tested individually



**Spectrum Research &
Testing Lab., Inc.**

No. 101-10, Ling 8,
Shan-Tong Li, Chung-Li
City, Taoyuan, Taiwan

TEST REPORT

Reference No.:A02120305
Report No.:FCCA02120305
FCC ID: PKW-WSB24-1
Page:6 of 6
Date:Dec.18, 2002

3. DESCRIPTION OF APPLIED STANDARDS

The EUT is a kind of wireless product and to be connected with a PC system for normal use. According to the specifications provided by the applicant, it must comply with the requirements of the following standards:

47 CFR Part 15, Subpart C

ANSI C63.4:1992

All tests have been performed and recorded as the above standards.



4. TECHNICAL CHARACTERISTICS TEST

4.1 CONDUCTED EMISSION TEST

4.1.1 LIMIT

Frequency (MHz)	Class A (dB μ V)		Class B (dB μ V)	
	Quasi-peak	Average	Quasi-peak	Average
0.15 - 0.5	79	66	66 - 56	56 - 46
0.50 - 5.0	73	60	56	46
5.0 - 30.0	73	60	60	50

NOTE :

1. The lower limit shall apply at the transition frequencies.
2. The limit decreases in line with the logarithm of the frequency in the range of 0.15 to 0.50 MHz.

4.1.2 TEST EQUIPMENT

The following test equipment was used for the test:

EQUIPMENT/ FACILITIES	SPECIFICATIONS	MANUFACTURER	MODEL#/ SERIAL#	DUE DATE OF CAL. & CAL. CENTER
EMI TEST RECEIVER	9 kHz TO 2750 MHz	ROHDE & SCHWARZ	ESHS30/ 826003/008	JUL. 2003 R&S
LISN	50 μ H, 50 ohm	SOLAR ELECTRONICS	8215-50-R-24-BNC / 924839	JUN. 2003 ETC
LISN	50 μ H, 50 ohm	SOLAR ELECTRONICS	9252-50-R-24-BNC / 951318	JUN. 2003 ETC

NOTE : The calibration interval of the above test equipment is one year and the calibrations are traceable to NML/ROC and NIST/USA.



4.1.3 TEST SETUP

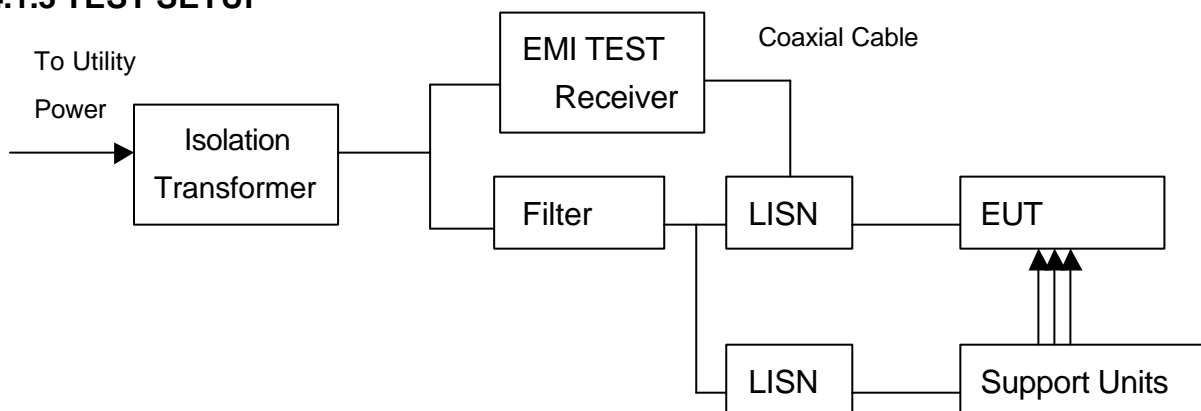

NOTE :

1. The EUT was put on a wooden table with 0.8m height above ground plane, and 0.4m away from reference ground plane (> 2mx2m).
2. For the actual test configuration, please refer to the photos of testing.

4.1.4 TEST PROCEDURE

The EUT was tested according to the requirement of ANSI C63.4 and CISPR 22. The frequency spectrum from 0.15 MHz to 30 MHz was investigated. The LISN used was 50 ohm/50μH as specified. All readings were quasi-peak and average values with 10 kHz resolution bandwidth of the test receiver. The EUT system was operated in all typical methods by users. Both lines of the power mains of EUT were measured and the cables connected to EUT and support units were moved to find the maximum emission levels for each frequency.

4.1.5 EUT OPERATING CONDITION

1. Set the EUT under normal condition continuously at link mode.
2. The EUT was used program to control channel when the EUT was tested RF power and emission.



P

4.1.6 TEST RESULT

Temperature:	<u>23 °C</u>	Humidity:	<u>65 %RH</u>
Ferquency Range:	<u>0.15 – 30 MHz</u>	Test Mode:	<u>Ch11</u>
Receiver Detector:	<u>Q.P. and AV.</u>	Tested By:	<u>James Lee</u>
Tested Power Port:	<u>Adapter for SB</u>		

Power Line Measured : Line

Freq. (MHz)	Correct. Factor (dB)	Reading Value (dB μ V)		Emission Level (dB μ V)		Limit (dB μ V)		Margin (dB)	
		Q.P.	AV.	Q.P.	AV.	Q.P.	AV.	Q.P.	AV.
0.194	0.20	35.9	32.8	36.1	33.0	63.9	53.9	-27.8	-20.9
0.370	0.20	34.1	31.3	34.3	31.5	58.5	48.5	-24.2	-17.0
0.600	0.20	35.9	32.2	36.1	32.4	56.0	46.0	-19.9	-13.6
1.447	0.20	38.4	32.3	38.6	32.5	56.0	46.0	-17.4	-13.5
13.650	0.47	38.1	38.0	38.6	38.5	60.0	50.0	-21.4	-11.5
21.906	0.64	33.4	26.0	34.0	26.6	60.0	50.0	-26.0	-23.4

Power Line Measured : Neutral

Freq. (MHz)	Correct. Factor (dB)	Reading Value (dB μ V)		Emission Level (dB μ V)		Limit (dB μ V)		Margin (dB)	
		Q.P.	AV.	Q.P.	AV.	Q.P.	AV.	Q.P.	AV.
0.193	0.20	42.5	40.8	42.7	41.0	63.9	53.9	-21.2	-12.9
0.383	0.20	36.2	32.7	36.4	32.9	58.2	48.2	-21.8	-15.3
1.514	0.20	37.9	32.0	38.1	32.2	56.0	46.0	-17.9	-13.8
5.400	0.32	22.0	20.0	22.3	20.3	60.0	50.0	-37.7	-29.7
13.649	0.47	40.5	36.9	41.0	37.4	60.0	50.0	-19.0	-12.6
20.820	0.62	29.5	22.3	30.1	22.9	60.0	50.0	-29.9	-27.1

NOTE :

1. Measurement uncertainty is less than 2dB
2. Emission level = Reading valus + Correction factor
3. Correction Factor = Cable loss + Insertion loss of LISN
4. "***": Measurement does not apply for this frequency.
5. Margin value = Emission level - Limit
6. The emission of other frequencies were very low against the limit.
7. "-": The Quasi-peak reading value also meets average limit and measurement with the average detector is unnecessary.



Temperature:	<u>23 °C</u>	Humidity:	<u>65 %RH</u>
Ferquency Range:	<u>0.15 – 30 MHz</u>	Test Mode:	<u>Ch11</u>
Receiver Detector:	<u>Q.P. and AV.</u>	Tested By:	<u>James Lee</u>
Tested Power Port:	<u>Adapter for Router</u>		

Power Line Measured : Line

Freq. (MHz)	Correct. Factor (dB)	Reading Value (dB μ V)		Emission Level (dB μ V)		Limit (dB μ V)		Margin (dB)	
		Q.P.	AV.	Q.P.	AV.	Q.P.	AV.	Q.P.	AV.
0.212	0.20	40.3	32.6	40.5	32.8	63.1	53.1	-22.6	-20.3
0.311	0.20	37.4	29.8	37.6	30.0	59.9	49.9	-22.3	-19.9
0.610	0.20	34.3	28.1	34.5	28.3	56.0	46.0	-21.5	-17.7
1.990	0.20	26.9	20.2	27.1	20.4	56.0	46.0	-28.9	-25.6
2.190	0.20	32.2	20.8	32.4	21.0	56.0	46.0	-23.6	-25.0
17.580	0.55	33.8	21.9	34.4	22.5	60.0	50.0	-25.7	-27.6

Power Line Measured : Neutral

Freq. (MHz)	Correct. Factor (dB)	Reading Value (dB μ V)		Emission Level (dB μ V)		Limit (dB μ V)		Margin (dB)	
		Q.P.	AV.	Q.P.	AV.	Q.P.	AV.	Q.P.	AV.
0.247	0.20	36.9	29.4	37.1	29.6	61.9	51.9	-24.8	-22.3
0.371	0.20	37.5	29.7	37.7	29.9	58.5	48.5	-20.8	-18.6
0.630	0.20	34.3	29.9	34.5	30.1	56.0	46.0	-21.5	-15.9
1.100	0.20	27.7	20.7	27.9	20.9	56.0	46.0	-28.1	-25.1
12.340	0.45	29.7	22.5	30.1	22.9	60.0	50.0	-29.9	-27.1
12.800	0.46	29.6	22.6	30.1	23.1	60.0	50.0	-29.9	-26.9

NOTE :

1. Measurement uncertainty is less than 2dB
2. Emission level = Reading valus + Correction factor
3. Correction Factor = Cable loss + Insertion loss of LISN
4. "": Measurement does not apply for this frequency.
5. Margin value = Emission level - Limit
6. The emission of other frequencies were very low against the limit.
7. "-": The Quasi-peak reading value also meets average limit and measurement with the average detector is unnecessary.



4.2 RADIATED EMISSION TEST

4.2.1 LIMIT

FCC Part15, Subpart C Section 15.209 limit of radiated emission for frequency below1000MHz. The emissions from an intentional radiator shall not exceed the field strength levels specified in the following table:

FREQUENCY (MHz)	DISTANCE (m)	FIELD STRENGTH (dBmV/m)
30 - 88	3	40.0
88 - 216	3	43.5
216 - 960	3	46.0
ABOVE 960	3	54.0

- NOTE** :
1. In the emission tables above , the tighter limit applies at the band edges.
 2. Distance refers to the distance between measuring instrument , antenna , and the closest point of any part of the device or system.

FCC Part 15, Section15.35(b) limit of radiated emission for frequency above 1000 MHz

FREQUENCY (MHz)	Class A (dBuV/m) (at 3m)		Class B (dBuV/m) (at 3m)	
	PEAK	AVERAGE	PEAK	AVERAGE
Above 1000	80.0	60.0	74.0	54.0



Spectrum Research & Testing Lab., Inc.
 No. 101-10, Ling 8,
 Shan-Tong Li, Chung-Li
 City, Taoyuan, Taiwan

TEST REPORT

Reference No.:A02120305
 Report No.:FCCA02120305
 FCC ID: PKW-WSB24-1
 Page:12 of 12
 Date:Dec.18, 2002

4.2.2 TEST EQUIPMENT

The following test equipment was used during the radiated emission test :

EQUIPMENT/ FACILITIES	SPECIFICATIONS	MANUFACTURER	MODEL#/ SERIAL#	DUE DATE OF CAL. & CAL. CENTER
EMI TEST RECEIVER	9 kHz TO 2750 MHz	ROHDE & SCHWARZ	ESCS30/ 836858/008	DEC. 2002 R&S
SPECTRUM	9KHz-26.5GHz	HP	8953E/ 3710A03220	MAY.2003 ETC
PRE-AMPLIFIER	1GHz-26.5GHz Gain:30dB	HP	8449B/ 3008A01019	NOV.2002 ETC
BI-LOG ANTENNA	25 MHz TO 2 GHz	EMCO	3142/9701-1124	JUL. 2003 ETC
HORN ANTENNA	1GHz to 18GHz	EMCO	3115/ 9602-4681	DEC.2002 ETC
HORN ANTENNA	15GHz to 40GHz	EMCO	3116/ 2567	JUL.2003 ETS
OATS	3 - 10 M measurement	SRT	SRT-1	MAY 2003

NOTE:

1. The calibration interval of the above test equipment is one year and the calibrations are traceable to NML/ROC and NIST/USA.
2. The Open Area Test Site (SRT-1) is registered by FCC with No. 90957 and VCCI with No. R-1081.
3. The Open Area Test Site (SRT-2) is registered by FCC with No. 98458 and VCCI with No. R-1168.



4.2.3 TEST SET-UP

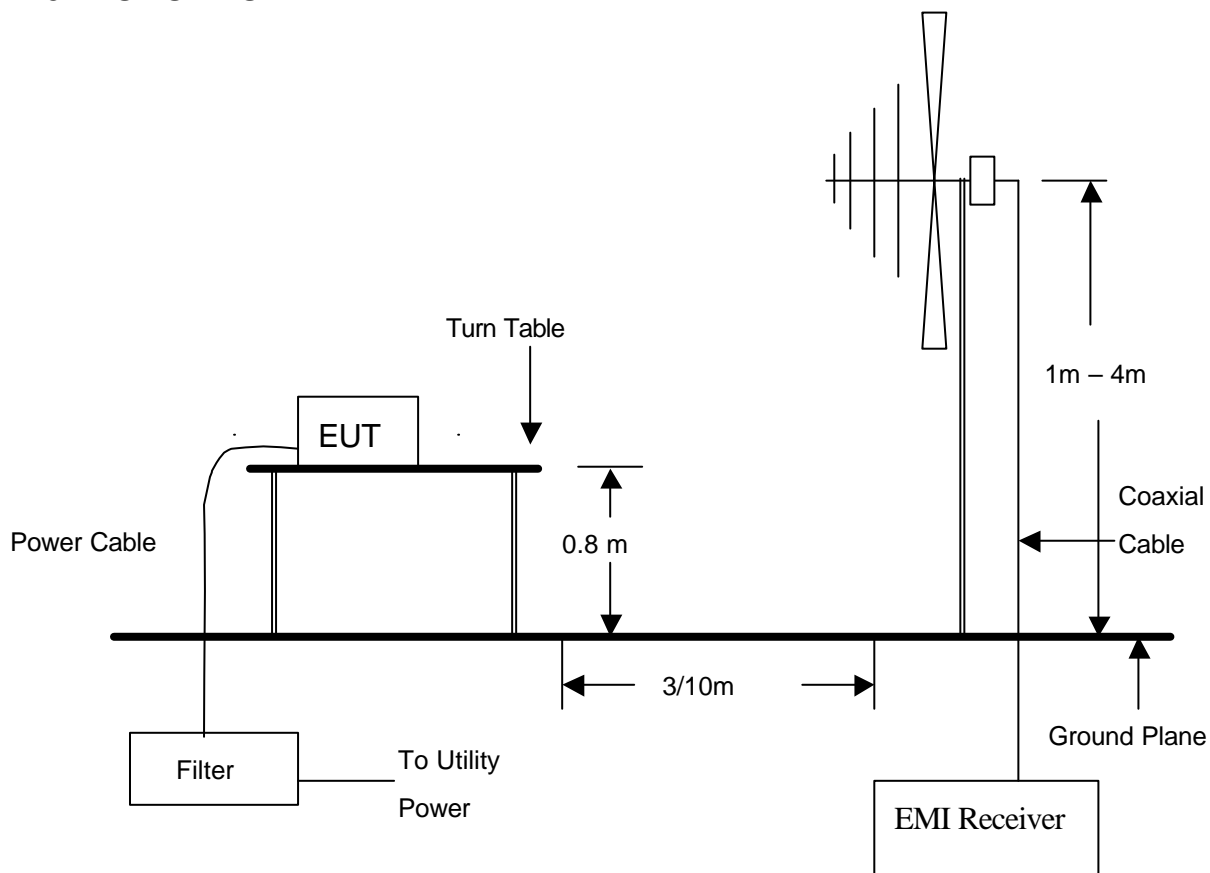

NOTE :

1. The EUT system was put on a wooden table with 0.8m heights above a ground plane.
2. For the actual test configuration, please refer to the photos of testing.



**Spectrum Research &
Testing Lab., Inc.**

No. 101-10, Ling 8,
Shan-Tong Li, Chung-Li
City, Taoyuan, Taiwan

TEST REPORT

Reference No.:A02120305
Report No.:FCCA02120305
FCC ID: PKW-WSB24-1
Page:14 of 14
Date:Dec.18, 2002

4.2.4 TEST PROCEDURE

The EUT was tested according to the requirement of ANSI C63.4 and CISPR 22. The measurements were made at an open area test site with 10 meter measurement distance under 1 GHz and with 3m distance above 1GHz. The frequency spectrum measured started from 30 MHz. Under 1 GHz. All readings were quasi-peak values with 120 kHz resolution bandwidth of the test receiver. Above 1 GHz, the measurements were made at an open area test site with 3 meter measurement distance and all readings were peak and average values with 1 MHz resolution bandwidth of the test receiver. The EUT system was operated in all typical methods by users. The cables connected to EUT and support units were moved to find the maximum emission levels for each frequency.

4.2.5 EUT OPERATING CONDITION

Same as section 4.1.5 of this report.



4.2.6 TEST RESULT

Temperature: 23°C Humidity: 65%RH
Frequency Range: 30 – 1000 MHz Test mode: Ch11
Receiver Detector: Q.P. Measured Distance: 3m
Tested by: James Lee

Antenna Polarization : Horizontal

Frequency (MHz)	Cable Loss (dB)	Antenna Factor (dB/m)	Reading Data (dB μ V)	Emission Level (dB μ V/m)	Limit (dB μ V/m)	Margin (dB)	EL(m)	AZ(°)
50.0000	1.07	10.80	5.1	17.0	40.0	-23.0	83	1.1
225.0138	1.81	11.55	14.5	27.9	46.0	-18.1	60	1.2
250.0164	1.96	12.65	20.6	35.2	46.0	-10.8	38	1.2
275.0197	1.92	13.53	12.6	28.0	46.0	-18.0	80	1.0
325.0219	2.08	15.03	9.3	26.4	46.0	-19.6	333	1.1
375.0250	2.15	15.90	12.5	30.6	46.0	-15.5	269	1.0
499.9872	2.94	17.99	13.4	34.3	46.0	-11.7	76	1.6
599.9854	2.71	20.67	19.5	42.9	46.0	-3.1	353	1.2
748.4855	3.01	21.78	7.5	32.3	46.0	-13.7	106	1.0
750.0510	2.95	21.80	10.2	35.0	46.0	-11.1	260	1.0
799.9799	3.00	22.11	13.5	38.6	46.0	-7.4	360	1.6
899.9768	2.88	23.59	9.7	36.2	46.0	-9.8	321	1.7



TEST REPORT

Antenna Polarization : Vertical

Frequency (MHz)	Cable Loss (dB)	Antenna Factor (dB/m)	Reading Data (dB μ V)	Emission Level (dB μ V/m)	Limit (dB μ V/m)	Margin (dB)	EL(m)	AZ(°)
50.0000	1.07	10.80	13.0	24.9	40.0	-15.1	0	1.0
250.0178	1.96	12.65	26.9	41.5	46.0	-4.5	92	1.1
300.0221	2.06	14.90	8.8	25.8	46.0	-20.2	26	1.6
325.0221	2.08	15.03	9.1	26.2	46.0	-19.8	30	1.3
349.9921	2.32	15.33	10.7	28.3	46.0	-17.7	250	1.1
399.9891	2.67	16.29	11.6	30.6	46.0	-15.4	77	1.4
449.9886	2.51	17.03	12.3	31.8	46.0	-14.2	61	1.1
499.9841	2.94	17.99	13.4	34.3	46.0	-11.7	140	1.3
599.9841	2.71	20.67	15.0	38.4	46.0	-7.6	90	1.0
649.9836	2.66	20.79	14.8	38.3	46.0	-7.7	200	1.0
748.4851	3.01	21.78	13.0	37.8	46.0	-8.2	30	1.4
750.0510	2.95	21.80	10.3	35.1	46.0	-11.0	343	1.9
899.9768	2.88	23.59	11.9	38.4	46.0	-7.6	75	1.3

- NOTE :**
1. Measurement uncertainty is less than 4dB
 2. "": Measurement does not apply for this frequency.
 3. Emission Level = Reading Value + Ant. Factor + Cable Loss
 4. The field strength of other emission frequencies were very low against the limit.



Spectrum Research & Testing Lab., Inc.
No. 101-10, Ling 8,
Shan-Tong Li, Chung-Li
City, Taoyuan, Taiwan

TEST REPORT

Reference No.:A02120305
Report No.:FCCA02120305
FCC ID: PKW-WSB24-1
Page:17 of 17
Date:Dec.18, 2002

Temperature: 23°C Humidity: 65%RH
 Frequency Range: 1 – 25 GHz Test mode: Ch1
 Receiver Detector: PK. or AV. Measured Distance: 3m
 Tested by: James Lee

Antenna Polarization : Horizontal

Freq./MHz	Correct. Factor (dB)	Ant. Fact. (dB)	Reading (dBuV)		Emission (dBuV/m)		Limit Line (dBuV/m)		Margin (dBuV/m)		AZ (o)	EL (m)
			PK	AV	PK	AV	PK	AV	PK	AV		
2037.75	-32.98	27.27	52.0	47.1	46.3	41.4	74.0	54.0	-27.7	-12.6	347	1.0
2411.35(F)	3.67	28.56	71.2	66.4	103.4	98.6	N/A	N/A	N/A	N/A	195	1.1
4824.00	-30.41	33.66	47.2	-	50.4	-	74.0	54.0	-23.6	-	0	1.0

Antenna Polarization : Vertical

Freq./MHz	Correct. Factor (dB)	Ant. Fact. (dB)	Reading (dBuV)		Emission (dBuV/m)		Limit Line (dBuV/m)		Margin (dBuV/m)		AZ (o)	EL (m)
			PK	AV	PK	AV	PK	AV	PK	AV		
2037.85	-32.98	27.27	51.6	41.3	45.8	35.6	74.0	54.0	-28.2	-18.4	108	1.0
2411.00(F)	3.67	28.02	78.5	73.1	110.2	104.8	N/A	N/A	N/A	N/A	82	1.3
4824.25	-30.41	33.12	49.1	36.8	51.8	39.5	74.0	54.0	-22.2	-14.5	22	1.0
7237.75	-28.98	36.29	50.5	39.2	57.8	46.5	74.0	54.0	-16.2	-7.5	355	1.0

- NOTE :**
1. Measurement uncertainty is less than 4dB
 2. "": Measurement does not apply for this frequency.
 - 3."-": The peak value of measurement is below the average limit,so the test with average detector is not necessary.
 4. Emission Level = Reading Value + Ant. Factor + Correct. Factor(incl:Cable Loss and Pre-Amplifier Gain)
 5. The field strength of other emission frequencies were very low against the limit.
 - 6.(F):The field strength of fundamental frequency.



Spectrum Research & Testing Lab., Inc.
No. 101-10, Ling 8,
Shan-Tong Li, Chung-Li
City, Taoyuan, Taiwan

TEST REPORT

Reference No.:A02120305
Report No.:FCCA02120305
FCC ID: PKW-WSB24-1
Page:18 of 18
Date:Dec.18, 2002

Temperature: 23°C Humidity: 65%RH
 Frequency Range: 1 – 25 GHz Test mode: Ch6
 Receiver Detector: PK. or AV. Measured Distance: 3m
 Tested by: James Lee

Antenna Polarization : Horizontal

Freq./MHz	Correct. Factor (dB)	Ant. Fact. (dB)	Reading (dBuV)		Emission (dBuV/m)		Limit Line (dBuV/m)		Margin (dBuV/m)		AZ (o)	EL (m)
			PK	AV	PK	AV	PK	AV	PK	AV		
2062.88	-32.86	27.32	49.3	43.4	43.7	37.9	74.0	54.0	-30.3	-16.1	100	13
2435.83(F)	3.67	28.07	69.7	64.5	101.4	96.2	N/A	N/A	N/A	N/A	191	2.0
4872.63	-30.29	33.70	47.6	-	51.0	-	74.0	54.0	-23.0	-	360	1.6

Antenna Polarization : Vertical

Freq/MHz	Correct. Factor (dB)	Ant. Fact. (dB)	Reading (dBuV)		Emission (dBuV/m)		Limit Line (dBuV/m)		Margin (dBuV/m)		AZ (o)	EL (m)
			PK	AV	PK	AV	PK	AV	PK	AV		
2062.88	-32.86	27.65	55.0	41.6	49.8	36.4	74.0	54.0	-24.2	-17.6	165	1.0
2435.05(F)	3.67	28.77	77.5	71.5	109.9	103.9	N/A	N/A	N/A	N/A	334	1.2
4872.00	-30.29	33.70	49.8	36.7	53.2	40.1	74.0	54.0	-20.8	-13.9	190	1.0

- NOTE :**
1. Measurement uncertainty is less than 4dB
 2. "": Measurement does not apply for this frequency.
 - 3."-": The peak value of measurement is below the average limit,so the test with average detector is not necessary.
 4. Emission Level = Reading Value + Ant. Factor + Correct. Factor(incl:Cable Loss and Pre-Amplifier Gain)
 5. The field strength of other emission frequencies were very low against the limit.
 - 6.(F):The field strength of fundamental frequency.



Spectrum Research & Testing Lab., Inc.
 No. 101-10, Ling 8,
 Shan-Tong Li, Chung-Li
 City, Taoyuan, Taiwan

TEST REPORT

Reference No.:A02120305
 Report No.:FCCA02120305
 FCC ID: PKW-WSB24-1
 Page:19 of 19
 Date:Dec.18, 2002

Temperature: 23°C Humidity: 65%RH
 Frequency Range: 1 – 25 GHz Test mode: Ch11
 Receiver Detector: PK. or AV. Measured Distance: 3m
 Tested by: James Lee

Antenna Polarization : Horizontal

Freq./MHz	Correct. Factor (dB)	Ant. Fact. (dB)	Reading (dBuV)		Emission (dBuV/m)		Limit Line (dBuV/m)		Margin (dBuV/m)		AZ (o)	EL (m)
			PK	AV	PK	AV	PK	AV	PK	AV		
2087.80	-32.60	27.37	49.5	42.0	44.2	36.8	74.0	54.0	-29.8	-17.2	355	1.2
2463.60(F)	3.67	28.13	68.7	63.5	100.5	95.3	N/A	N/A	N/A	N/A	170	1.0
2483.67	-32.19	28.17	61.3	-36.6	57.3	-40.6	74.0	54.0	-16.7	-94.6	105	1.0
4175.50	-30.12	32.69	47.7	38.5	50.3	41.1	74.0	54.0	-23.7	-12.9	200	1.8

Antenna Polarization : Vertical

Freq/MHz	Correct. Factor (dB)	Ant. Fact. (dB)	Reading (dBuV)		Emission (dBuV/m)		Limit Line (dBuV/m)		Margin (dBuV/m)		AZ (o)	EL (m)
			PK	AV	PK	AV	PK	AV	PK	AV		
2087.80	-32.60	27.37	50.5	44.0	45.3	38.8	74.0	54.0	-28.7	-15.2	345	1.0
2463.60(F)	3.67	28.70	75.3	69.7	107.7	102.1	N/A	N/A	N/A	N/A	300	1.4
2483.67	-32.19	28.74	68.0	53.8	64.6	50.3	74.0	54.0	-9.4	-3.7	350	1.0
4923.75	-30.23	33.74	50.4	38.6	53.9	42.1	74.0	54.0	-20.1	-11.9	182	1.0
7386.05	-28.94	36.41	46.9	36.2	54.4	43.7	74.0	54.0	-19.6	-10.3	180	1.3

- NOTE :**
1. Measurement uncertainty is less than 4dB
 2. "": Measurement does not apply for this frequency.
 3. Emission Level = Reading Value + Ant. Factor + Correct. Factor(incl:Cable Loss and Pre-Amplifier Gain)
 4. The field strength of other emission frequencies were very low against the limit.
 - 5.(F):The field strength of fundamental frequency.



Spectrum Research & Testing Lab., Inc.
 No. 101-10, Ling 8,
 Shan-Tong Li, Chung-Li
 City, Taoyuan, Taiwan

TEST REPORT

Reference No.:A02120305
 Report No.:FCCA02120305
 FCC ID: PKW-WSB24-1
 Page:20 of 20
 Date:Dec.18, 2002

4.3 6dBc BANDWIDTH TEST

4.3.1 LIMIT

FCC Part15, Subpart C Section 15.247(2). The minimum 6 dB bandwidth shall be at least 500 kHz.

4.3.2 TEST EQUIPMENT

The following test equipment was used during the test :

EQUIPMENT/ FACILITIES	SPECIFICATIONS	MANUFACTURER	MODEL#/ SERIAL#	DUE DATE OF CAL. & CAL. CENTER
SPECTRUM	9kHz-7GHz	ROHDE & SCHWARZ	FSP7/ 839511/010	MAR.2003 R & S

NOTE: The calibration interval of the above test equipment is one year and the calibrations are traceable to NML/ROC and NIST/USA.

4.3.3 TEST SET-UP

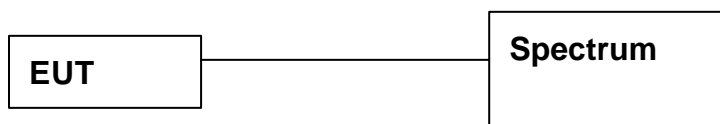

The EUT was connected to a spectrum through a 50 RF cable.

4.3.4 TEST PROCEDURE

The EUT was operating in transmitter mode and could be controlled its channel. Printed out the test result from the spectrum by hard copy function.

4.3.5 EUT OPERATING CONDITION

Same as section 4.1.5 of this report.



4.3.6 TEST RESULT

Temperature: 25°C Humidity: 60%RH
 Spectrum Detector: PK Tested by James Lee
 Test Result PASS

CHANNEL NUMBER	CHANNEL FREQUENCY (MHz)	6dB DOWN BW (MHz)	MINIMUM LIMIT (MHz)
1	2412	11.12	0.5
6	2437	11.12	0.5
11	2462	10.72	0.5

CH1:

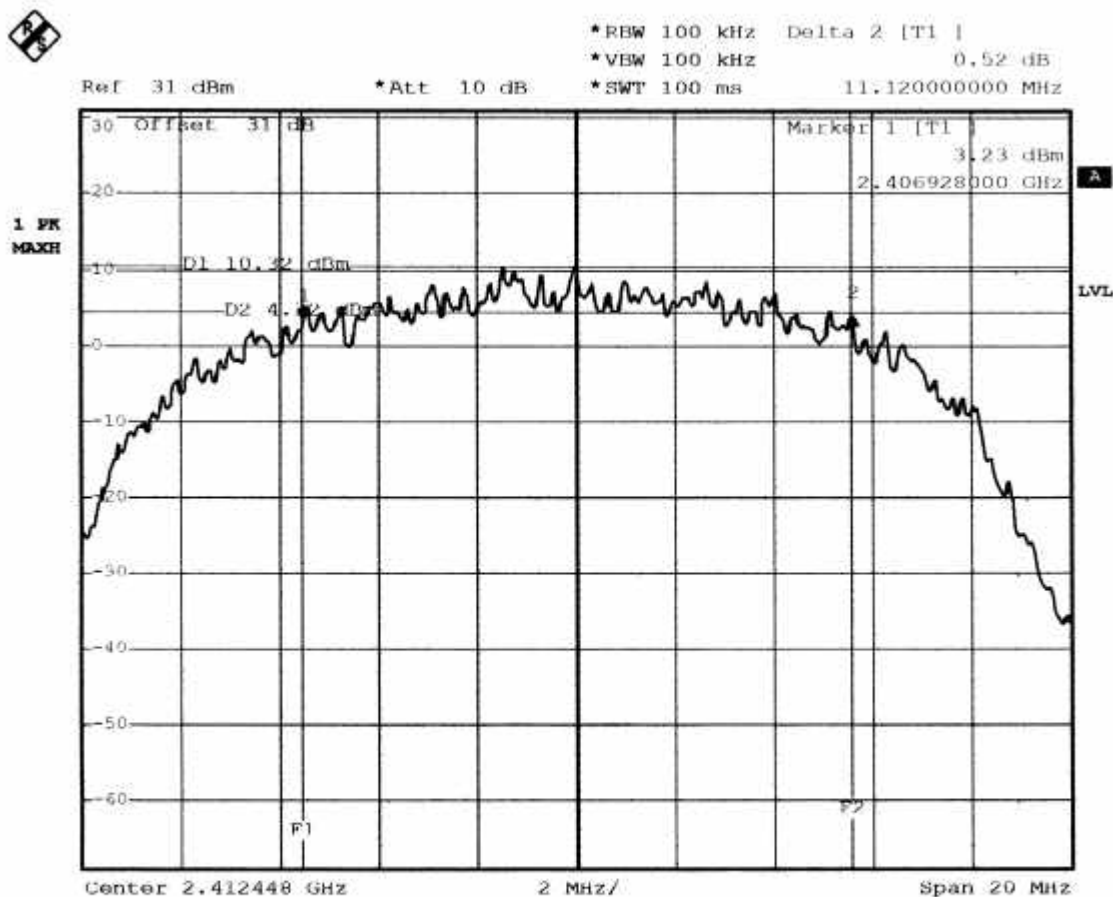



Spectrum Research & Testing Lab., Inc.
No. 101-10, Ling 8,
Shan-Tong Li, Chung-Li
City, Taoyuan, Taiwan

TEST REPORT

Reference No.:A02120305
Report No.:FCCA02120305
FCC ID: PKW-WSB24-1
Page:22 of 22
Date:Dec.18, 2002

CH6:

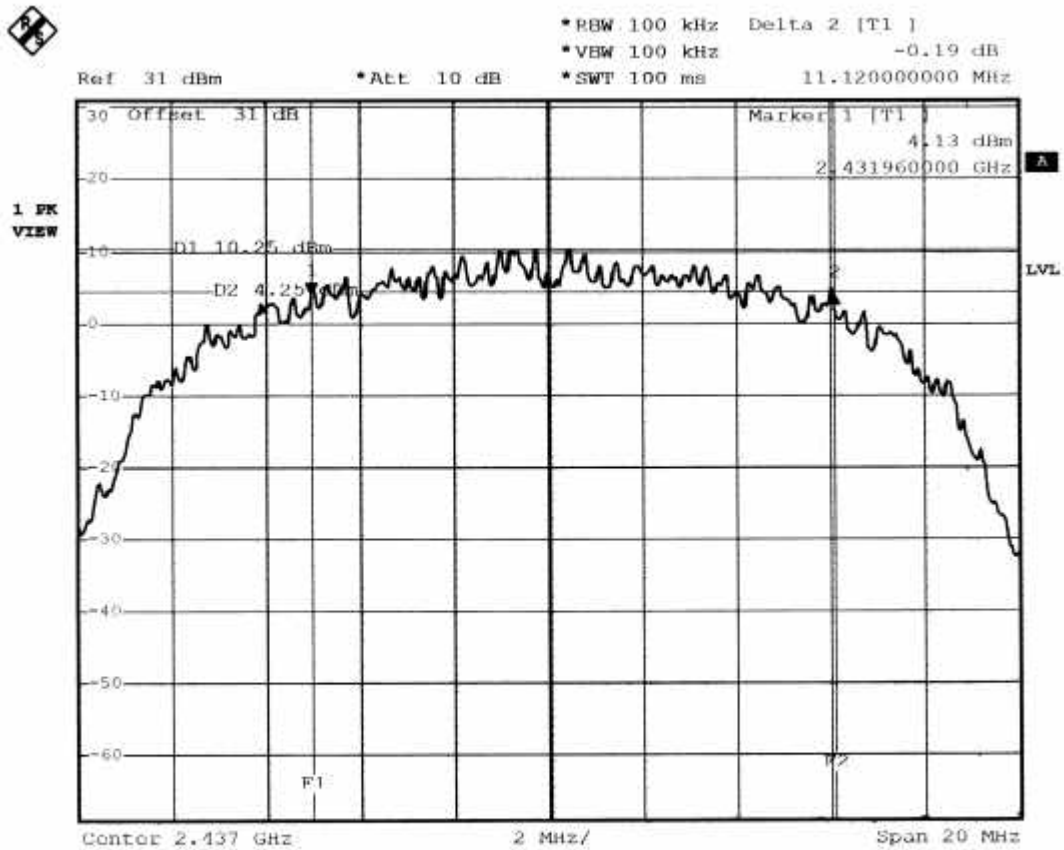

Date: 2.DEC.2002 09:59:45



TEST REPORT

CH11:

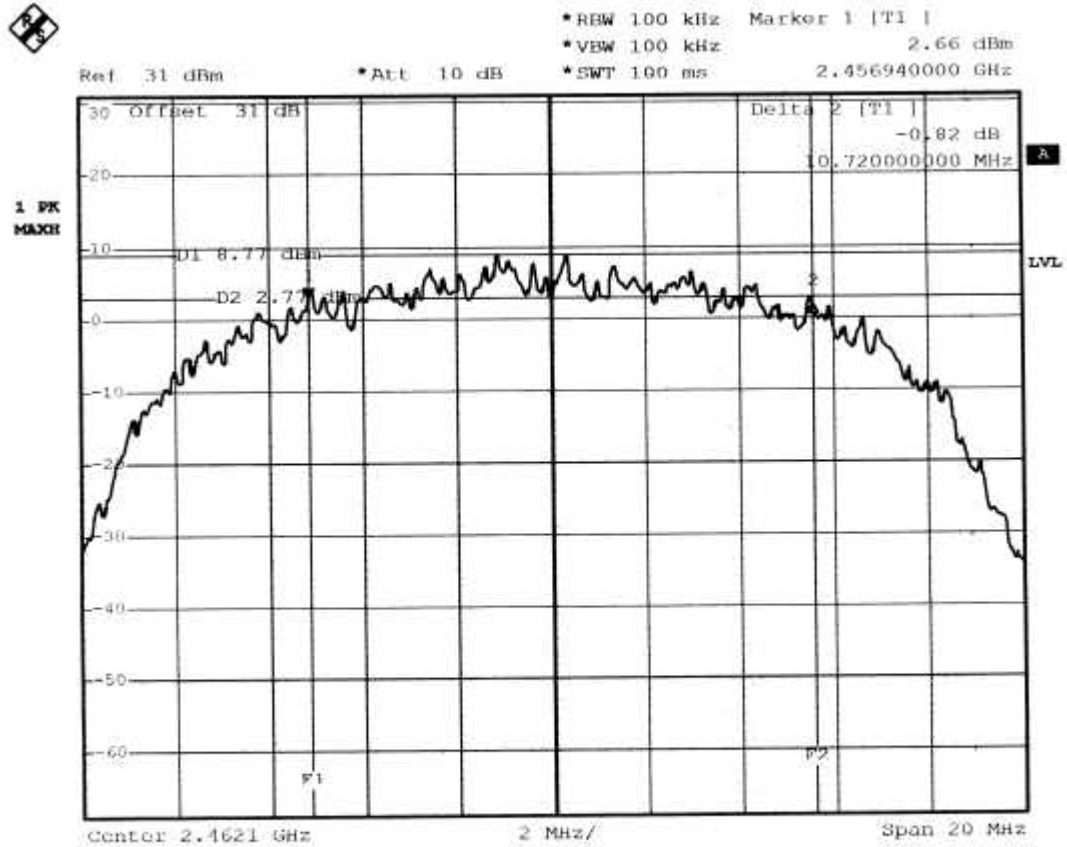

Date: 2.DEC.2002 10:35:03



Spectrum Research & Testing Lab., Inc.
No. 101-10, Ling 8,
Shan-Tong Li, Chung-Li
City, Taoyuan, Taiwan

TEST REPORT

Reference No.:A02120305
Report No.:FCCA02120305
FCC ID: PKW-WSB24-1
Page:24 of 24
Date:Dec.18, 2002

4.4 PEAK POWER TEST

4.4.1 LIMIT

FCC Part15, Subpart C Section 15.247.

FREQUENCY RANGE (MHz)	LIMIT (W)
902-928	1(30dBm)
2400-2483.5	1(30dBm)
5725-5850	1(30dBm)

4.4.2 TEST EQUIPMENT

The following test equipment was used during the test :

EQUIPMENT/ FACILITIES	SPECIFICATIONS	MANUFACTURER	MODEL#/ SERIAL#	DUE DATE OF CAL. & CAL. CENTER
SPECTRUM	9kHz-7GHz	ROHDE & SCHWARZ	FSP7/ 839511/010	MAR. 2003 R & S
POWER METER	N/A	BOONTON	4232A/ 29001	MAY. 2003 ETC
POWER SENSOR	DC-8GHz 50	BOONTON	51011EMC/ 31181	MAY. 2003 ETC

NOTE: The calibration interval of the above test equipment is one year and the calibrations are traceable to NML/ROC and NIST/USA.



4.4.3 TEST SET-UP



The EUT was connected to a spectrum through a 50 Ω RF cable.

4.4.4 TEST PROCEDURE

The EUT was operating in transmitter mode and could be controlled its channel.
Printed out the test result from the spectrum by hard copy function.
Recorded the read value of the power meter.

4.4.5 EUT OPERATING CONDITION

Same as section 4.1.5 of this report.



Spectrum Research & Testing Lab., Inc.
 No. 101-10, Ling 8,
 Shan-Tong Li, Chung-Li
 City, Taoyuan, Taiwan

TEST REPORT

Reference No.:A02120305
 Report No.:FCCA02120305
 FCC ID: PKW-WSB24-1
 Page:26 of 26
 Date:Dec.18, 2002

4.4.6 TEST RESULT

Temperature: 23°C Humidity: 65%RH
 Spectrum Detector: PK Tested by James Lee
 Test Result PASS

CHANNEL NUMBER	CHANNEL FREQUENCY (MHz)	PEAK POWER OUTPUT (dBm)	PEAK POWER LIMIT (dBm)
1	2411.9680	20.5	30
6	2436.7200	20.8	30
11	2462.0864	18.7	30

CH1:

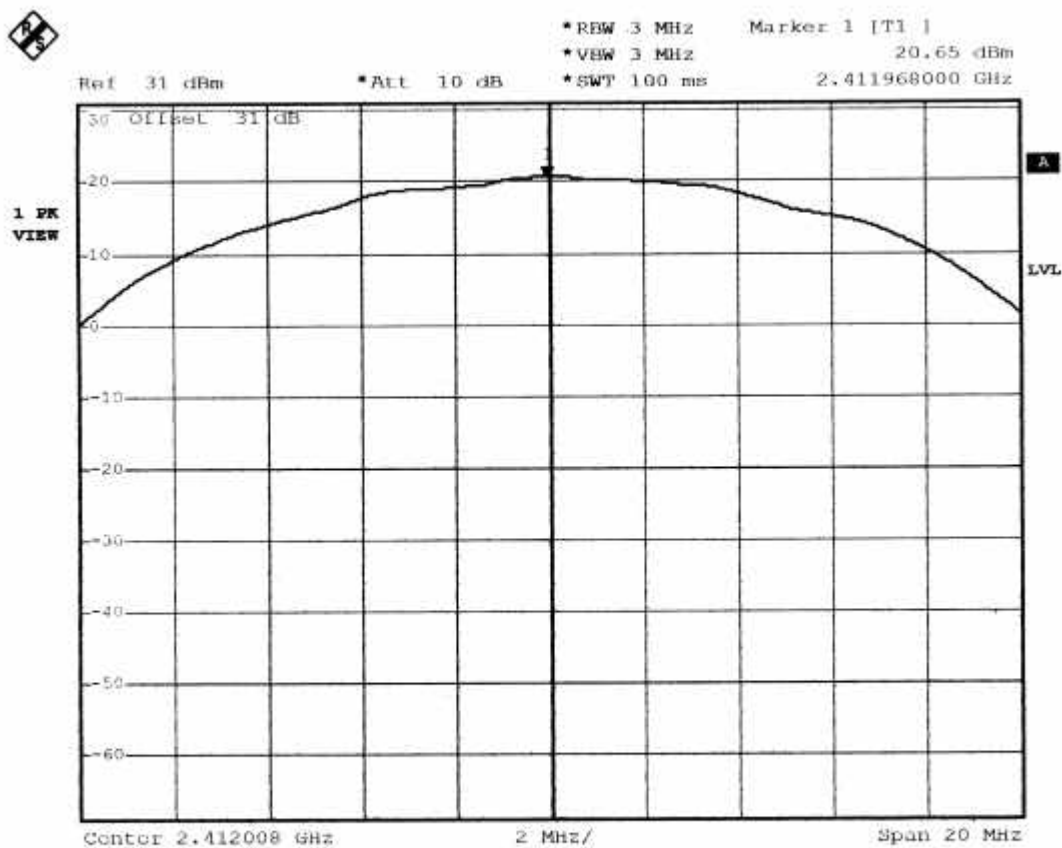

Date: 2.DEC.2002 10:12:01



TEST REPORT

CH6:

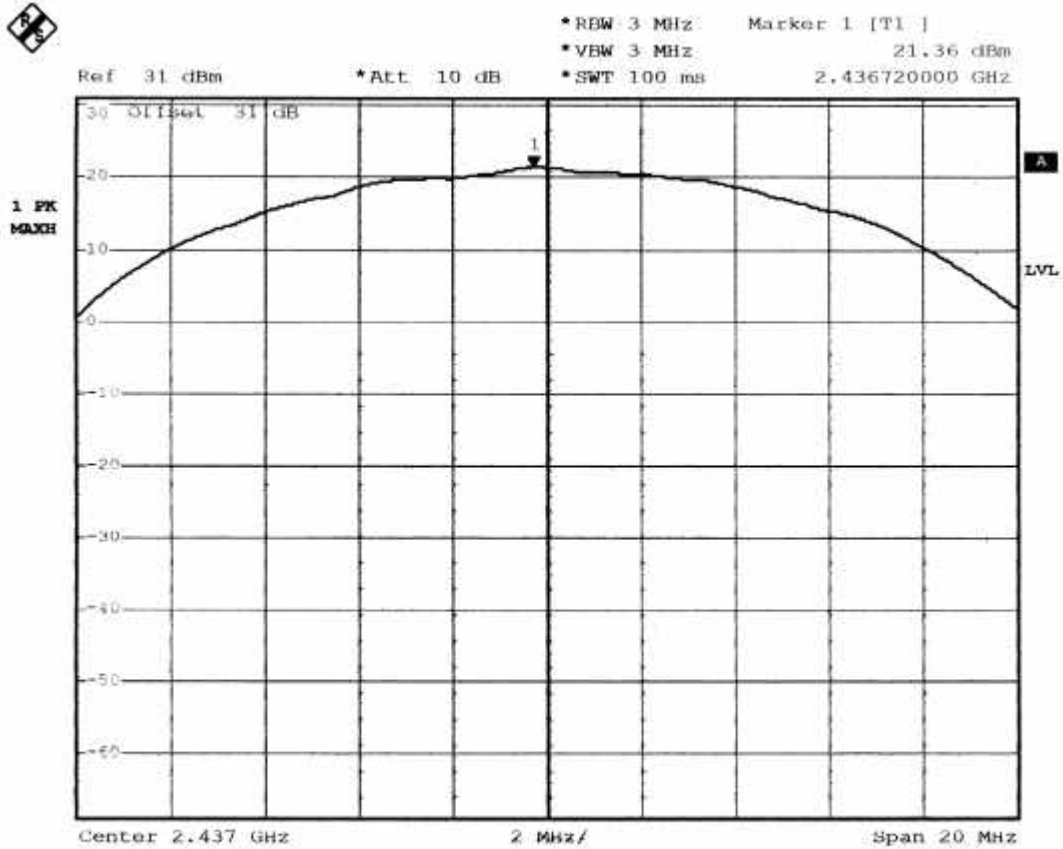

Date: 2.DEC.2002 09:56:35



CH11:

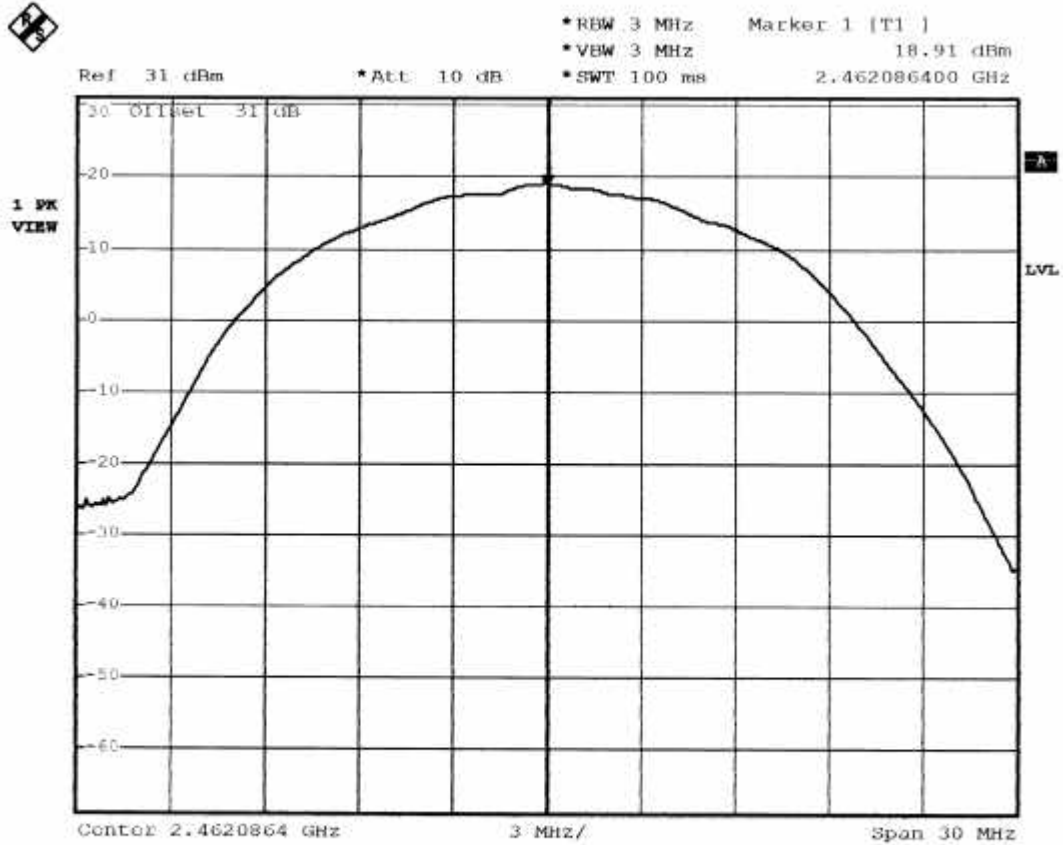

Date: 2.DEC.2002 10:41:43



4.5 BAND EDGE TEST

4.5.1 LIMIT

FCC Part15, Subpart C Section 15.247. In any 100 kHz bandwidth outside the frequency band in which the spread spectrum intentional radiator is operating, the radio frequency power that is produced by the intentional radiator shall be at least 20 dB below that in the 100 kHz bandwidth within the band that contains the highest level of the desired power, based on either an RF conducted or a radiated measurement. Attenuation below the general limits specified in Section 15.209(a) is not required. In addition, radiated emissions which fall in the restricted bands, as defined in Section 15.205(a), must also comply with the radiated emission limits specified in Section 15.209(a) (see Section 15.205(c)).

OPERATING FREQUENCY RANGE (MHz)	SPURIOUS EMISSION FREQUENCY (MHz)	LIMIT	
		Peak power ration to emission(dBc)	Emission level(dBuV/m)
902-928	<902	>20	NA
	>928	>20	NA
	960-1240	NA	54
2400-2483.5	<2400	>20	NA
	>2483.5-2500	NA	54
5725-5850	<5350-5460	NA	54
	<5725	>20	NA
	>5850	>20	NA



Spectrum Research & Testing Lab., Inc.
No. 101-10, Ling 8,
Shan-Tong Li, Chung-Li
City, Taoyuan, Taiwan

TEST REPORT

Reference No.:A02120305
Report No.:FCCA02120305
FCC ID: PKW-WSB24-1
Page:30 of 30
Date:Dec.18, 2002

4.5.2 TEST EQUIPMENT

The following test equipment was used during the test :

EQUIPMENT/ FACILITIES	SPECIFICATIONS	MANUFACTURER	MODEL#/ SERIAL#	DUE DATE OF CAL. & CAL. CENTER
SPECTRUM	9kHz-7GHz	ROHDE & SCHWARZ	FSP7/ 839511/010	MAR.2003 R & S
SPECTRUM	9KHz-26.5GHz	HP	8953E/ 3710A03220	May.2003 ETC
PRE-AMPLIFIER	1GHz-26.5GHz Gain:30dB	HP	8449B/ 3008A01019	NOV.2002 ETC
HORN ANTENNA	1GHz to 18GHz	EMCO	3115/ 9602-4681	Dec.2002 ETC
OATS	3 - 10 M measurement	SRT	SRT-1	MAY 2003

NOTE: The calibration interval of the above test equipment is one year and the calibrations are traceable to NML/ROC and NIST/USA.



4.5.3 TEST SET-UP

FOR RF CONDUCTED TEST (dBc)



The EUT was connected to the spectrum through a 50 Ω RF cable.

FOR RADIATED EMISSION TEST

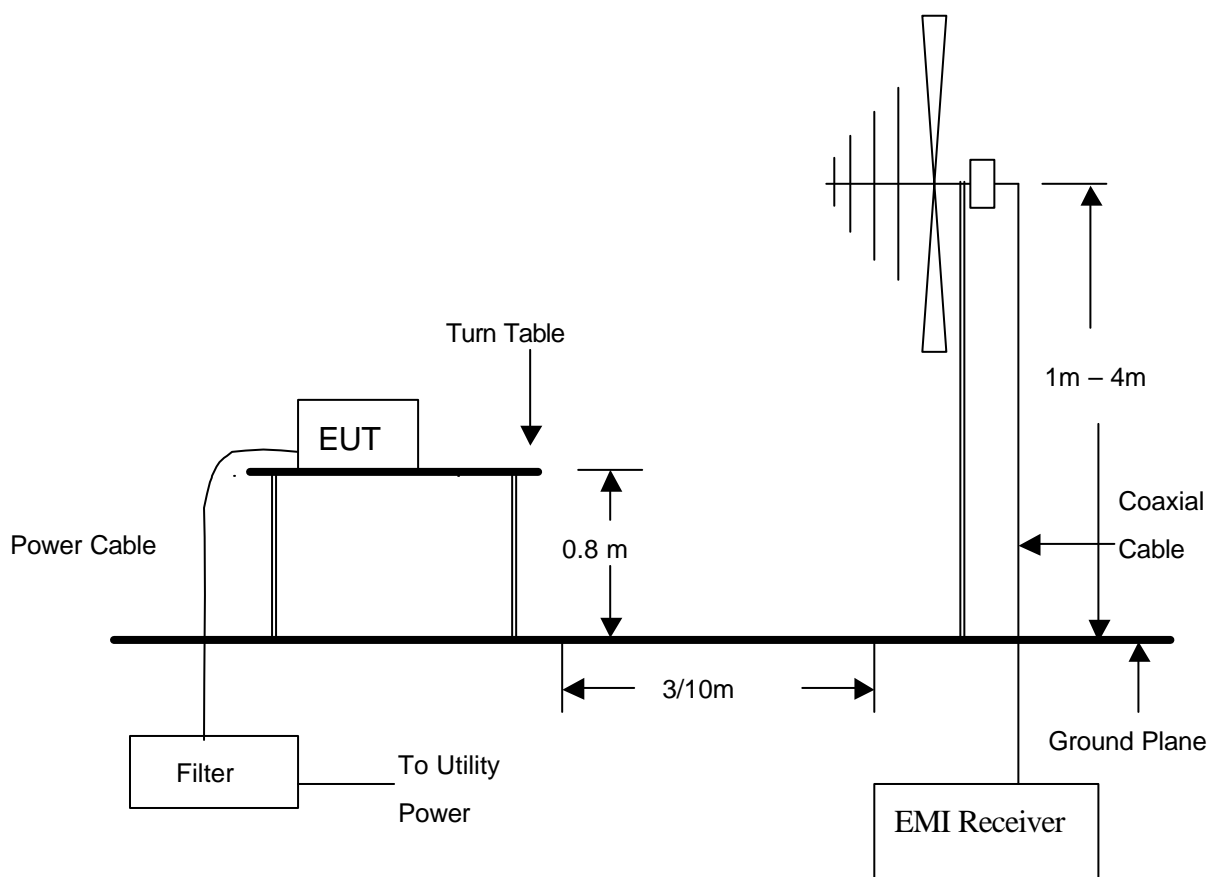

NOTE :

1. The EUT system was put on a wooden table with 0.8m heights above a ground plane.
2. For the actual test configuration, please refer to the photos of testing.



4.5.4 TEST PROCEDURE

1. The EUT was operating in transmitter mode and could be controlled its channel.
Printed out the test result from the spectrum by hard copy function.
2. The EUT was tested according to the requirement of ANSI C63.4 and CISPR 22.
The measurements were made at an open area test site with 10 meter measurement distance under 1 GHz and with 3m distance above 1GHz. The frequency spectrum measured started from 30 MHz. Under 1 GHz. All readings were quasi-peak values with 120 kHz resolution bandwidth of the test receiver. Above 1 GHz, the measurements were made at an open area test site with 3 meter measurement distance and all readings were peak and average values with 1 MHz resolution bandwidth of the test receiver. The EUT system was operated in all typical methods by users. The cables connected to EUT and support units were moved to find the maximum emission levels for each frequency.

4.5.5 EUT OPERATING CONDITION

Same as section 4.1.5 of this report.



4.5.6 TEST RESULT

4.5.6 TEST RESULT

Temperature: 23°C Humidity: 65%RH
 Spectrum Detector: PK & AV Tested by James Lee
 Test Result PASS

1. Conducted test

Frequency (MHz)	PEAK POWER OUTPUT (dBm)	Emission read Value(dBm)	Result of Band edge (dBc)	Band edge LIMIT (dBc)
2399.1551	10.4 (see note 1)	-28.58	38.98	>20dBc
2520.4000	8.9 (see note2)	-36.6	45.5	>20dBc

2. Radiated emission test

Frequency (MHz)	Correct. Factor (dB)	Ant. Fact. (dB)	Antenna polarization (H/V)	PEAK POWER OUTPUT (dBuV/m)	Emission read Value(dBuV/m)	Band edge LIMIT (dBuV/m)
2037.75	-32.98	27.27	H	104.8 (see note3)	41.4 (see note3)	54
2483.67	-32.19	28.74	V	102.1 (see note 3)	50.3 (see note3)	54

NOTE :

- 1.The peak power output power sees the plot <2400MHz of marker 1's level.
- 2.The peak power output power sees the plot >2483.5MHz of marker 1's level.
- 3.The test result was same to the test report 4.2.6.



TEST REPORT

<2400MHz:

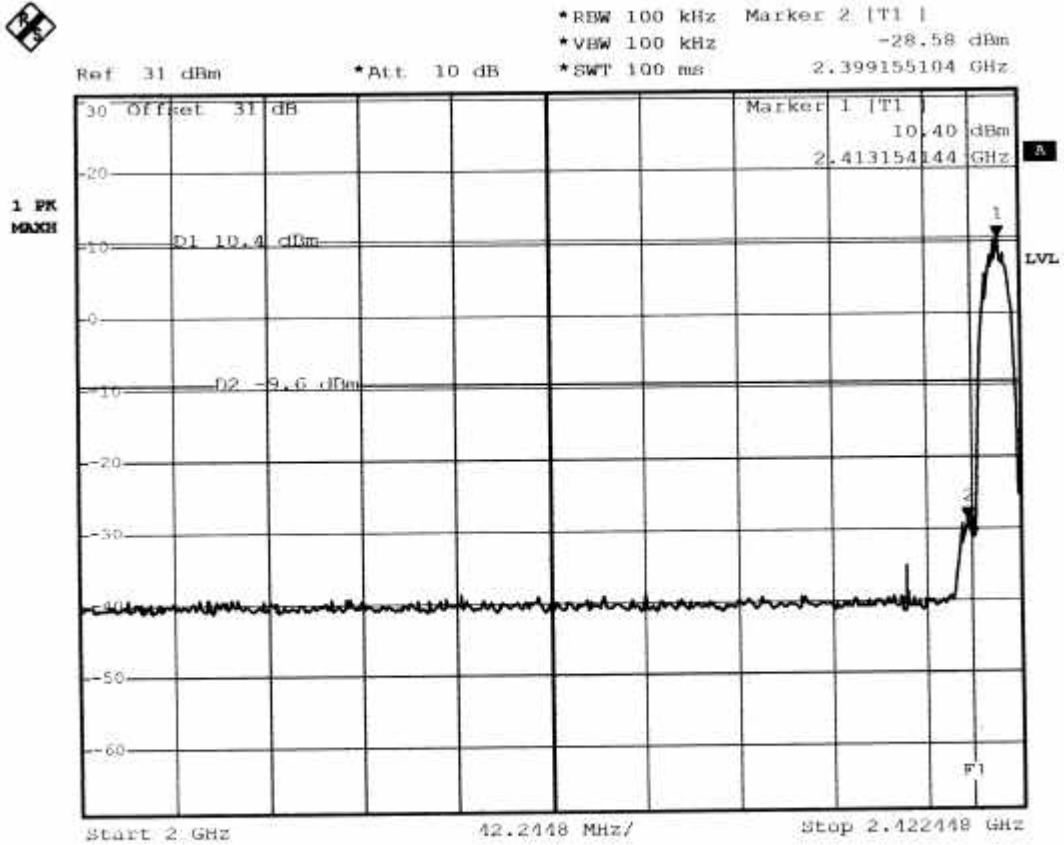

Date: 2.DEC.2002 10:26:53



TEST REPORT

>2483.5MHz

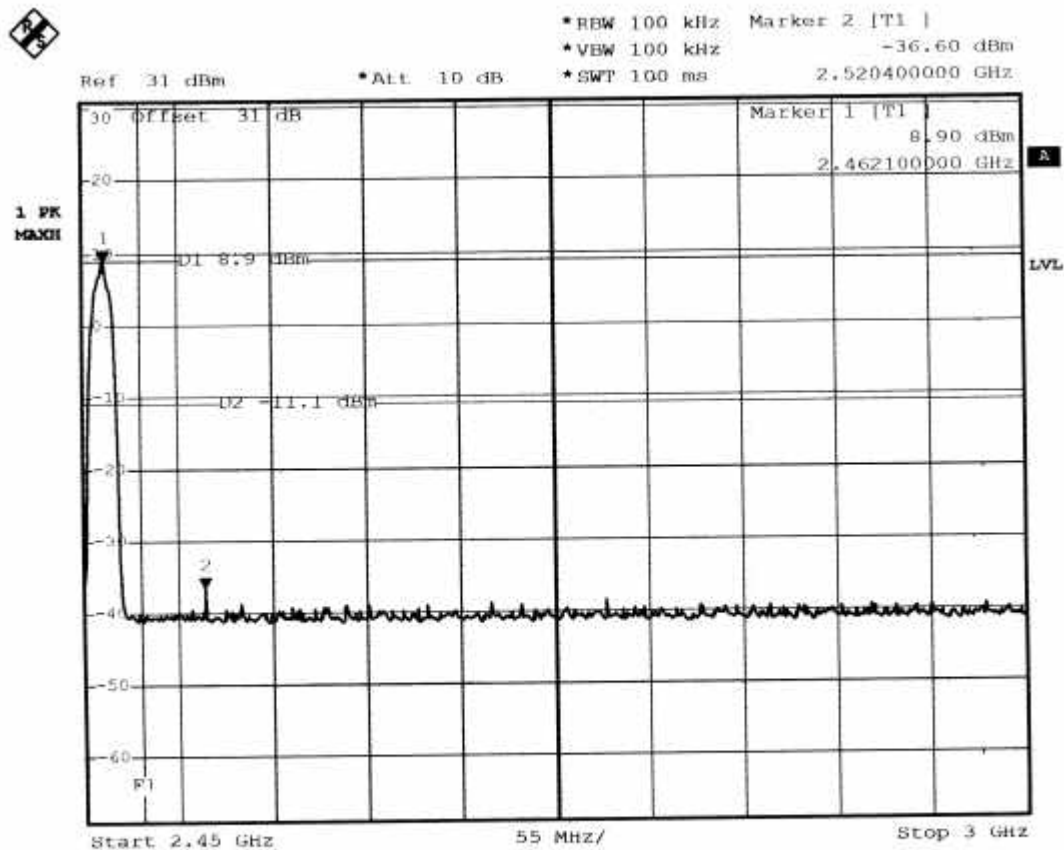

Date: 2,DEC,2002 10:30:42



4.6 POWER DENSITY TEST

4.6.1 LIMIT

FCC Part15, Subpart C Section 15.247.

FREQUENCY RANGE (MHz)	Limit(dBm/kHz)
902-928	8dBm/3kHz
2400-2483.5	
5725-5850	

4.6.2 TEST EQUIPMENT

The following test equipment was used during the radiated emission test :

EQUIPMENT/ FACILITIES	SPECIFICATIONS	MANUFACTURER	MODEL#/ SERIAL#	DUE DATE OF CAL. & CAL. CENTER
SPECTRUM	9kHz-7GHz	ROHDE & SCHWARZ	FSP7/ 839511/010	MAR.2003 R & S

NOTE: The calibration interval of the above test equipment is one year and the calibrations are traceable to NML/ROC and NIST/USA.

4.6.3 TEST SET-UP

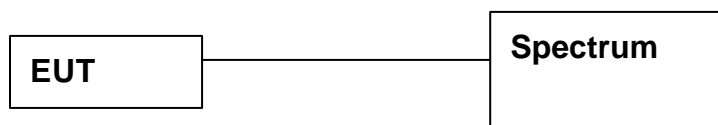

The EUT was connected to a spectrum through a 50 Ohm RF cable.

4.6.4 TEST PROCEDURE

The EUT was operating in transmitter mode and could be controlled its channel. Printed out the test result from the spectrum by hard copy function.

4.6.5 EUT OPERATING CONDITION

Same as section 4.1.5 of this report.



Spectrum Research & Testing Lab., Inc.
No. 101-10, Ling 8,
Shan-Tong Li, Chung-Li
City, Taoyuan, Taiwan

TEST REPORT

Reference No.:A02120305
Report No.:FCCA02120305
FCC ID: PKW-WSB24-1
Page:37 of 37
Date:Dec.18, 2002

4.6.6 TEST RESULT

Temperature: 23°C Humidity: 65%RH
Spectrum Detector: PK Tested by James Lee
Test Result PASS

CHANNEL NUMBER	CHANNEL FREQUENCY (MHz)	RF POWER LEVEL IN 3KHz BW (dBm/3kHz)	MAXIMUM LIMIT (dBm/3kHz)
1	2411.3086	-2.40	8
6	2436.0940	-2.07	8
11	2461.307	-4.82	8



CH1:

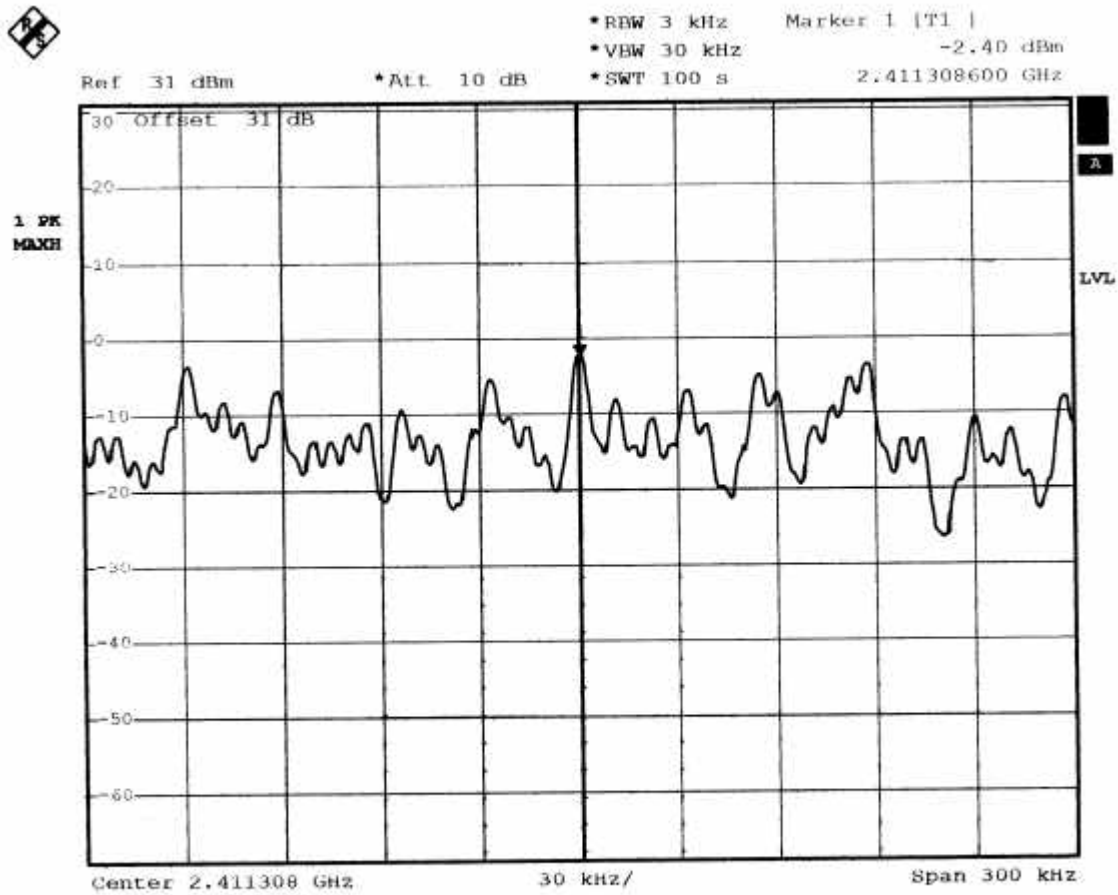

Date: 2.DEC.2002 10:08:32



Spectrum Research & Testing Lab., Inc.
No. 101-10, Ling 8,
Shan-Tong Li, Chung-Li
City, Taoyuan, Taiwan

TEST REPORT

Reference No.:A02120305
Report No.:FCCA02120305
FCC ID: PKW-WSB24-1
Page:39 of 39
Date:Dec.18, 2002

CH6:

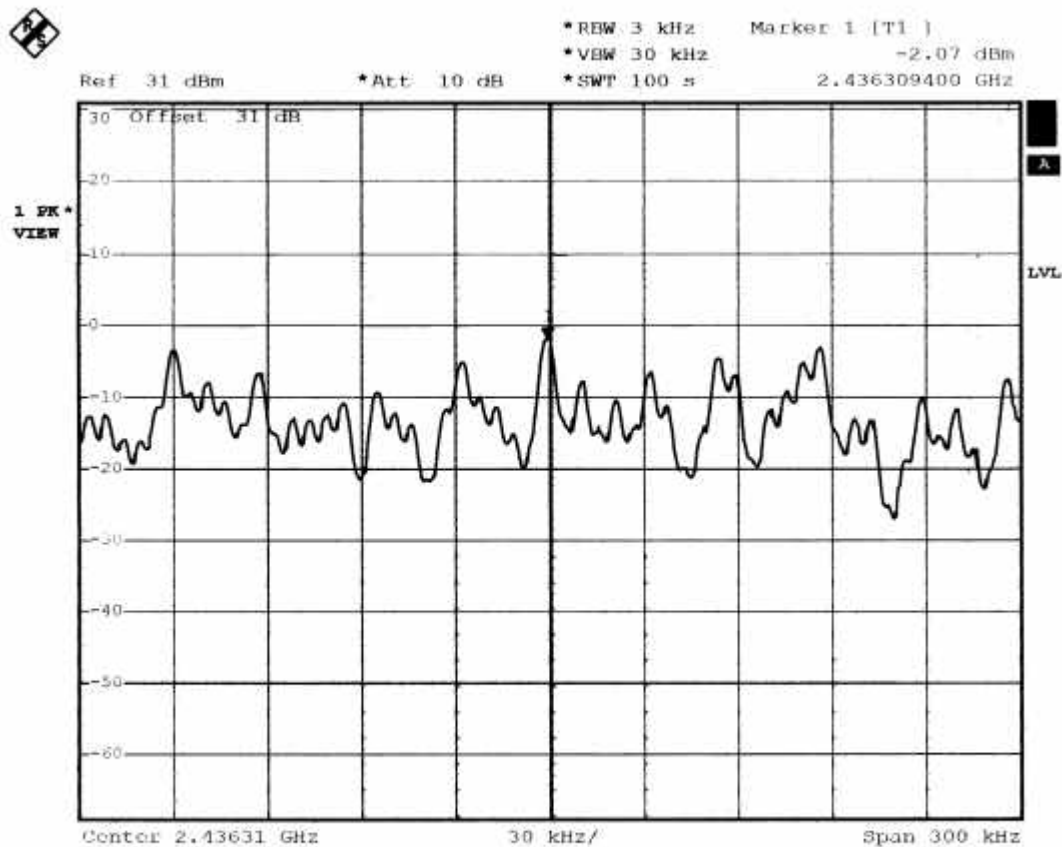

Date: 2.DEC.2002 10:02:19



CH11:

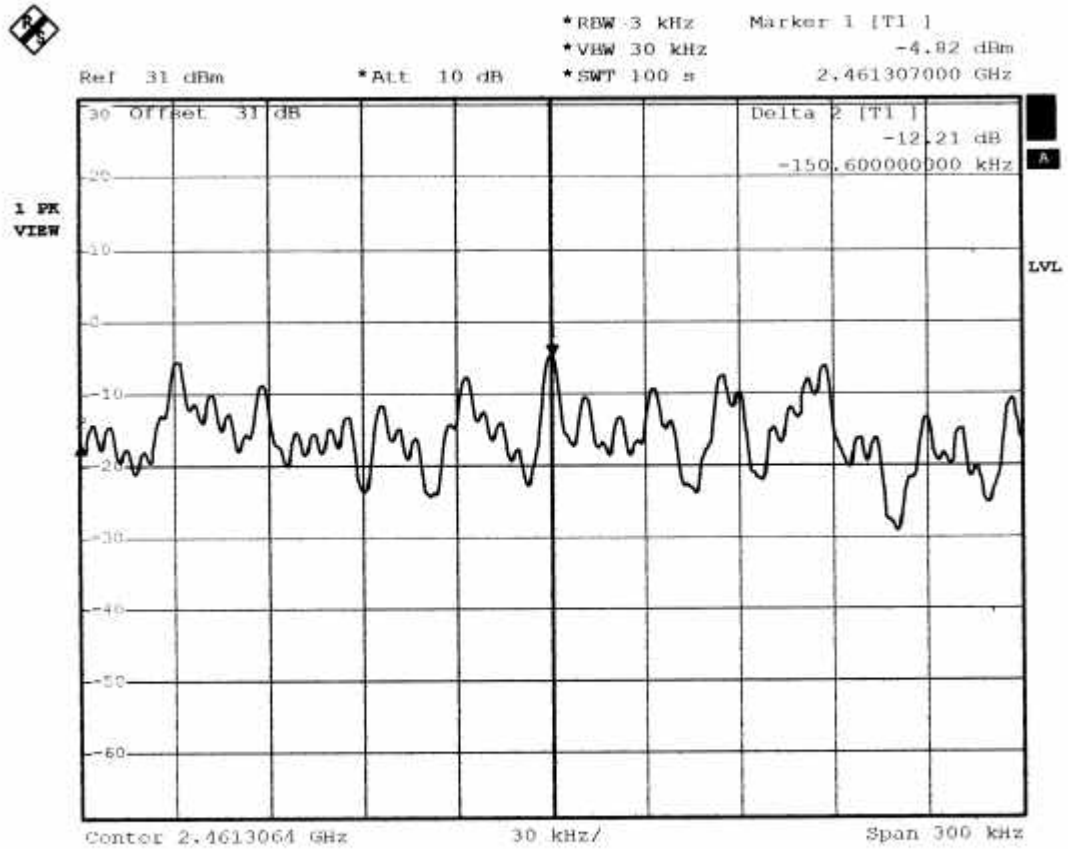

Date: 2.DEC.2002 10:38:59



4.7 RF POWER EXPOSURE EVALUATION TEST

4.7.1 LIMIT

According to the requirement of IEEE C95.1 and FCC OET Bulletin 65.

Limits for Occupational/Controlled Exposure

Frequency Range (MHz)	Electric Field Strength(E) (V/m)	Magnetic Field Strength(H) (A/m)	Power density (S) (mW/cm ²)	Averaging Time E ² , H ² or S (minutes)
0.3-3.0	614	1.63	(100)*	6
3.0-30	1842/f	4.89/f	(900/f ²)*	6
30-300	61.4	0.163	1.0	6
300-1500	--	--	f/300	6
1500-100,000	--	--	5	6

Limits for General Population/Uncontrolled Exposure

Frequency Range (MHz)	Electric Field Strength(E) (V/m)	Magnetic Field Strength(H) (A/m)	Power density (S) (mW/cm ²)	Averaging Time E ² , H ² or S (minutes)
0.3-1.34	614	1.63	(100)*	30
1.34-30	824/f	2.19/f	(180/f ²)*	30
30-300	27.5	0.073	0.2	30
300-1500	--	--	f/1500	30
1500-100,000	--	--	1.0	30

f = frequency in MHz *Plane-wave equivalent power density

NOTE 1: Occupational/controlled limits apply in situations in which persons are exposed as a consequence of their employment provided those persons are fully aware of the potential for exposure and can exercise control over their exposure. Limits for occupational/controlled exposure also apply in situations when an individual is transient through a location where occupational/controlled limits apply provided he or she is made aware of the potential for exposure.

NOTE 2: General population/uncontrolled exposures apply in situations in which the general public may be exposed, or in which persons that are exposed as a consequence of their employment may not be fully aware of the potential for exposure or cannot exercise control over their exposure.



Spectrum Research & Testing Lab., Inc.
 No. 101-10, Ling 8,
 Shan-Tong Li, Chung-Li
 City, Taoyuan, Taiwan

TEST REPORT

Reference No.:A02120305
 Report No.:FCCA02120305
 FCC ID: PKW-WSB24-1
 Page:42 of 42
 Date:Dec.18, 2002

4.7.2 TEST EQUIPMENT

The following test equipment was used during the test :

EQUIPMENT/ FACILITIES	SPECIFICATIONS	MANUFACTURER	MODEL#/ SERIAL#	DUE DATE OF CAL. & CAL. CENTER
POWER METER	N/A	BOONTON	4232A/ 29001	MAY. 2003 ETC
POWER SENSOR	DC-8GHz 50	BOONTON	51011EMC/ 31181	MAY. 2003 ETC

NOTE: The calibration interval of the above test equipment is one year and the calibrations are traceable to NML/ROC and NIST/USA.

4.7.3 TEST SET-UP

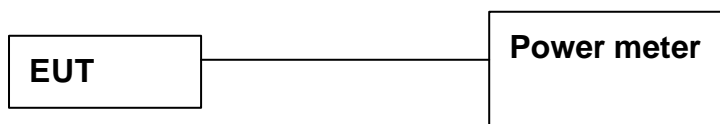

The EUT was connected to the spectrum through a 50 Ω RF cable.



4.7.4 TEST PROCEDURE

1. The EUT was operating in transmitter mode and could be controlled its channel. The power meter read power value.
2. The EUT uses an sleeve dipole antenna and the antenna gain is 2dBi declared by manufacturer.
3. As discussed in OET Bulletin 65, calculations can be made to predict RF field strength and power density levels around typical RF sources. For example, in the case of a non-directional antenna, a prediction for power density in the far-field of the antenna can be made by use of the general Equations (1) or (2) below [for conversion to electric or magnetic field strength see Equation (3) above]. These equations are generally accurate in the far-field of an antenna but will over-predict power density in the near field, where it could be used for making a " worst case" or conservative prediction.

$$S=PG/4 R^2 \quad (\text{Eq.1})$$

$$S=EIRP/4 R^2 \quad (\text{Eq. 2})$$

$$S=E^2/3770=37.7H^2 \quad (\text{Eq. 3})$$

where: S = power density (mW/cm²)

E = electric field strength (V/m)

H = magnetic field strength (A/m)

S = power density (in appropriate units, e.g. mW/cm²)

P = power input to the antenna (in appropriate units, e.g., mW)

G = power gain of the antenna in the direction of interest relative to an isotropic radiator (dBi)

R = distance to the center of radiation of the antenna (appropriate units, e.g., cm)

where: EIRP = equivalent (or effective) isotropically radiated power

4.7.5 EUT OPERATING CONDITION

Same as section 4.1.5 of this report.



Spectrum Research & Testing Lab., Inc.
No. 101-10, Ling 8,
Shan-Tong Li, Chung-Li
City, Taoyuan, Taiwan

TEST REPORT

Reference No.:A02120305
Report No.:FCCA02120305
FCC ID: PKW-WSB24-1
Page:44 of 44
Date:Dec.18, 2002

4.7.6 RESULT

Temperature: 25°C Humidity: 60%RH
Spectrum Detector: PK Tested by James Lee
Result PASS

CHANNEL NUMBER	CHANNEL FREQUENCY (MHz)	RF Output Power (mW)	Result calculated when nearby person (cm)	Limit when nearby person (cm)
1	2412	112.2	3.76	20
6	2437	120.2	3.89	20
11	2462	117.5	3.06	20

NOTE: The EUT uses an sleeve dipole antenna and the antenna gain is 2dBi (1.58 numeric)



5. Antenna application

5.1 Antenna requirement

The EUT' s antenna is met the requirement of FCC part15C section15.203 and 15.204.

FCC part15C section15.247 requirement:

Systems operating in the 2400-2483.5 MHz band that are used exclusively for fixed, point-to-point operations may employ transmitting antennas with directional gain greater than 6 dBi provided the maximum peak output power of the intentional radiator is reduced by 1 dB for every 3 dB that the directional gain of the antenna exceeds 6 dBi.

5.2 Result

The EUT' s antenna used a sleeve dipole antenna. The antenna' s gain is 2dBi and meets the requirement.



Spectrum Research & Testing Lab., Inc.

No. 101-10, Ling 8,
Shan-Tong Li, Chung-Li
City, Taoyuan, Taiwan

TEST REPORT

Reference No.:A02120305
Report No.:FCCA02120305
FCC ID: PKW-WSB24-1
Page:46 of 46
Date:Dec.18, 2002

6. TERMS OF ABRIVATION

AV.	Average detection
AZ(°)	Turn table azimuth
Correct.	Correction
EL(m)	Antenna height (meter)
EUT	Equipment Under Test
Horiz.	Horizontal direction
LISN	Line Impedance Stabilization Network
NSA	Normalized Site Attenuation
Q.P.	Quasi-peak detection
SRT Lab	Spectrum Research & Testing Laboratory, Inc.
Vert.	Vertical direction