



FCC RADIO TEST REPORT

FCC ID : PKRISGM2000B
Equipment : Wireless Hotspot Modem
Brand Name : Inseego
Model Name : M2000B
 : M2000E
Marketing Name : M2000
Applicant : Inseego Corporation
 : 9710 Scranton Road Suite 200, San Diego, CA 92121
Manufacturer : Inseego Corporation
 : 9710 Scranton Road Suite 200, San Diego, CA 92121
Standard : FCC 47 CFR Part 2, 24(E), 27

The product was received on Feb. 02, 2021 and testing was started from Feb. 12, 2021 and completed on Mar. 30, 2021. We, Sporton International Inc. EMC & Wireless Communications Laboratory, would like to declare that the tested sample has been evaluated in accordance with the test procedures given in ANSI / TIA-603-E and has been in compliance with the applicable technical standards.

The test results in this variant report apply exclusively to the tested model / sample. Without written approval of Sporton International Inc. EMC & Wireless Communications Laboratory, the test report shall not be reproduced except in full.

Louis Wu

Approved by: Louis Wu

Sporton International Inc. EMC & Wireless Communications Laboratory

No. 52, Huaya 1st Rd., Guishan Dist., Taoyuan City 333, Taiwan (R.O.C.)



Table of Contents

History of this test report..... 3

Summary of Test Result..... 4

1 General Description 6

 1.1 Product Feature of Equipment Under Test..... 6

 1.2 Modification of EUT 7

 1.3 Testing Location 8

 1.4 Applicable Standards..... 9

2 Test Configuration of Equipment Under Test 10

 2.1 Test Mode..... 10

 2.2 Connection Diagram of Test System..... 12

 2.3 Support Unit used in test configuration and system 12

 2.4 Measurement Results Explanation Example..... 12

 2.5 Frequency List of Low/Middle/High Channels 13

3 Conducted Test Items..... 17

 3.1 Measuring Instruments 17

 3.2 Conducted Output Power and ERP/EIRP 18

 3.3 Peak-to-Average Ratio 19

 3.4 Occupied Bandwidth..... 20

 3.5 Conducted Band Edge 21

 3.6 Conducted Spurious Emission 22

 3.7 Frequency Stability 23

4 Radiated Test Items 24

 4.1 Measuring Instruments 24

 4.2 Radiated Spurious Emission Measurement 26

5 List of Measuring Equipment..... 27

6 Uncertainty of Evaluation..... 29

Appendix A. Test Results of Conducted Test

Appendix B. Test Results of Radiated Test

Appendix C. Test Setup Photographs



History of this test report

Report No.	Version	Description	Issued Date
FG041658-02B	01	Initial issue of report	Apr. 21, 2021



Summary of Test Result

Report Clause	Ref Std. Clause	Test Items	Result (PASS/FAIL)	Remark
3.2	§2.1046	Conducted Output Power	Reporting only	-
	§22.913 (a)(5)	Effective Radiated Power (n5)	Pass	
	§27.50 (c)(10)	Effective Radiated Power (n12) (n71)		
	§24.232 (c) §27.50 (h)(2)	Equivalent Isotropic Radiated Power (n2) (n25) (n7) (n38) (n41)		
	§27.50 (d)(4)	Equivalent Isotropic Radiated Power (n66)		
3.3	§24.232 (d) §27.50 (d)(5)	Peak-to-Average Ratio	Pass	-
3.4	§2.1049	Occupied Bandwidth	Reporting only	-
3.5	§2.1051 §22.917 (a) §24.238 (a) §27.53 (g) §27.53 (h)	Conducted Band Edge Measurement (n2) (n5) (n12) (n25) (n66) (n71)	Pass	-
	§2.1051 §27.53 (m)(4)	Conducted Band Edge Measurement (n7) (n38) (n41)		
3.6	§2.1051 §22.917 (a) §24.238 (a) §27.53 (g) §27.53 (h)	Conducted Spurious Emission (n2) (n5) (n12) (n25) (n66) (n71)	Pass	-
	§2.1051 §27.53 (m)(4)	Conducted Spurious Emission (n7) (n38) (n41)		
3.7	§2.1055 §24.235 §27.54	Frequency Stability Temperature & Voltage	Pass	-
4.2	§2.1053 §22.917 (a) §24.238 (a) §27.53 (g) §27.53 (h)	Radiated Spurious Emission (n2) (n5) (n12) (n25) (n66) (n71)	Pass	Under limit 7.93 dB at 5172.000 MHz
	§2.1051 §27.53 (m)(4)	Radiated Spurious Emission (n7) (n38) (n41)		

Remark: This is a variant report by changing WWAN function by software. All the test cases were performed on original report which can be referred to Sporton Report Number FG041658-03C.



Declaration of Conformity:

The test results with all measurement uncertainty excluded are presented in accordance with the regulation limits or requirements declared by manufacturers.

Comments and Explanations:

The declared of product specification for EUT presented in the report are provided by the manufacturer, and the manufacturer takes all the responsibilities for the accuracy of product specification.

Reviewed by: Wii Chang

Report Producer: Lucy Wu



1 General Description

1.1 Product Feature of Equipment Under Test

Product Specification subjective to this Test Standard	
Tx Frequency	5G NR n2: 1852.5 MHz ~ 1907.5 MHz 5G NR n5: 826.5 MHz ~ 846.5 MHz 5G NR n7: 2502.5 MHz ~ 2567.5 MHz 5G NR n12: 701.5 MHz ~ 713.5 MHz 5G NR n25: 1852.5 MHz ~ 1912.5 MHz 5G NR n38: 2580 MHz ~ 2610 MHz 5G NR n41: 2506.02 MHz ~ 2679.99 MHz 5G NR n66: 1712.5 MHz ~ 1777.5 MHz 5G NR n71: 668.0 MHz ~ 693.0 MHz
Rx Frequency	5G NR n2: 1932.5 MHz ~ 1987.5 MHz 5G NR n5: 871.5 MHz ~ 891.5 MHz 5G NR n7: 2622.5 MHz ~ 2687.5 MHz 5G NR n12: 731.5 MHz ~ 743.5 MHz 5G NR n25: 1932.5 MHz ~ 1992.5 MHz 5G NR n38: 2580 MHz ~ 2610 MHz 5G NR n41: 2506.02 MHz ~ 2679.99 MHz 5G NR n66: 2112.5 MHz ~ 2197.5 MHz 5G NR n71: 668.0 MHz ~ 693.0 MHz
Bandwidth	5G NR n2: 5MHz / 10MHz / 15MHz / 20MHz 5G NR n5: 5MHz / 10MHz / 15MHz / 20MHz 5G NR n7: 5MHz / 10MHz / 15MHz / 20MHz 5G NR n12: 5MHz / 10MHz / 15MHz 5G NR n25: 5MHz / 10MHz / 15MHz / 20MHz 5G NR n38: 20MHz 5G NR n41: 20MHz / 40MHz / 50MHz / 60MHz / 80MHz / 90MHz / 100MHz 5G NR n66: 5MHz / 10MHz / 15MHz / 20MHz 5G NR n71: 5MHz / 10MHz / 15MHz / 20MHz
Antenna Type	Fixed Internal Antenna
Type of Modulation	5G NR: PI/2 BPSK / QPSK / 16QAM / 64QAM / 256QAM



Product Specification subjective to this standard	
Antenna Gain	<p><Ant. 0> 5G NR n2: 3.6 dBi 5G NR n5: 0.2 dBi 5G NR n7: 2.9 dBi 5G NR n12: 0.2 dBi 5G NR n25: 3.6 dBi 5G NR n38: 2.3 dBi 5G NR n41: 2.9 dB 5G NR n66: 3.3 dBi 5G NR n71: 0 dBi</p> <p><Ant. 1> 5G NR n5: -2.1 dBi 5G NR n71: -0.5 dBi</p> <p><Ant. 8> 5G NR n2: 0.8 dBi 5G NR n7: 0.8 dBi 5G NR n25: 0.9 dBi 5G NR n38: 0.6 dBi 5G NR n41: 0.6 dB 5G NR n66: 0.1 dBi</p>

Remark: The above EUT's information was declared by manufacturer. Please refer to Comments and Explanations in report summary.

1.2 Modification of EUT

No modifications are made to the EUT during all test items.



1.3 Testing Location

Test Site	Sporton International Inc. EMC & Wireless Communications Laboratory
Test Site Location	No.52, Huaya 1st Rd., Guishan Dist., Taoyuan City 333, Taiwan (R.O.C.) TEL: +886-3-327-3456 FAX: +886-3-328-4978
Test Site No.	Sporton Site No.
	TH05-HY
Test Engineer	Ivy Yeh
Temperature	22~25°C
Relative Humidity	48~66%

Test Site	Sporton International Inc. Wensan Laboratory
Test Site Location	No.58, Aly. 75, Ln. 564, Wenhua 3rd, Rd., Guishan Dist., Taoyuan City 333010, Taiwan (R.O.C.) TEL: +886-3-327-0868 FAX: +886-3-327-0855
Test Site No.	Sporton Site No.
	03CH12-HY (TAF Code: 3786)
Test Engineer	Jack Cheng, Lance Chiang and Chuan Chu
Temperature	21.3~24.5°C
Relative Humidity	54~65%
Remark	The Radiated Spurious Emission test item subcontracted to Sporton International Inc. Wensan Laboratory

Note: The test site complies with ANSI C63.4 2014 requirement.

FCC Designation No.: TW1190 and TW0007



1.4 Applicable Standards

According to the specifications of the manufacturer, the EUT must comply with the requirements of the following standards:

- ♦ ANSI C63.26-2015
- ♦ ANSI / TIA-603-E
- ♦ FCC 47 CFR Part 2, 24(E), 27
- ♦ FCC KDB 971168 D01 Power Meas. License Digital Systems v03r01
- ♦ FCC KDB 412172 D01 Determining ERP and EIRP v01r01
- ♦ FCC KDB 414788 D01 Radiated Test Site v01r01.

Remark:

1. All test items were verified and recorded according to the standards and without any deviation during the test.
2. The TAF code is not including all the FCC KDB listed without accreditation.



2 Test Configuration of Equipment Under Test

2.1 Test Mode

Antenna port conducted and radiated test items listed below are performed according to KDB 971168 D01 Power Meas. License Digital Systems v03r01 with maximum output power.

For radiated measurement, pre-scanned in three orthogonal panels, X, Y, Z. The worst cases (<Ant. 0>: X Plane for 5G NR n7A; Y Plane for 5G NR n2A, n12A, n38A, n66A; Z Plane for 5G NR n5A; <Ant. 0+8>: Y Plane for EN-DC 5A-n2A, EN-DC 66A-n2A, EN-DC 5A-n7A, EN-DC 12A-n7A, EN-DC 12A-n25A, EN-DC 5A-n38A, EN-DC 12A-n38A, EN-DC 71A-n38A, EN-DC 2A-n41A, EN-DC 4A-n41A, EN-DC 25A-n41A, EN-DC 26A-n41A, EN-DC 5A-n66A, EN-DC 71A-n66A; <Ant. 8+0>: X Plane for EN-DC 2A-n5A, EN-DC 2A-n12A, EN-DC 66A-n12A; Z Plane for EN-DC 7A-n5A, EN-DC 66A-n5A, EN-DC 66A-n7A, EN-DC 7A-n66A, EN-DC 7A-n71A) were recorded in this report.

Test Items	NR Band	Bandwidth (MHz)										Modulation					RB #			Test Channel				
		5	10	15	20	40	50	60	80	90	100	PI/2 BPSK	QPSK	16QAM	64QAM	256QAM	1	Half	Full	L	M	H		
Max. Output Power	n2	v	v	v	v	-	-	-	-	-	-	v	v	v	v	v	v	v	v	v	v	v	v	v
	n5	v	v	v	v	-	-	-	-	-	-	v	v	v	v	v	v	v	v	v	v	v	v	v
	n7	v	v	v	v	-	-	-	-	-	-	v	v	v	v	v	v	v	v	v	v	v	v	v
	n12	v	v	v	-	-	-	-	-	-	-	v	v	v	v	v	v	v	v	v	v	v	v	v
	n25	v	v	v	v	-	-	-	-	-	-	v	v	v	v	v	v	v	v	v	v	v	v	v
	n38	-	-	-	v	-	-	-	-	-	-	v	v	v	v	v	v	v	v	v	v	v	v	v
	n41	-	-	-	v	v	v	v	v	v	v	v	v	v	v	v	v	v	v	v	v	v	v	v
	n66	v	v	v	v	-	-	-	-	-	-	v	v	v	v	v	v	v	v	v	v	v	v	v
n71	v	v	v	v	-	-	-	-	-	-	v	v	v	v	v	v	v	v	v	v	v	v	v	
Peak-to-Average Ratio	n2	-	-	-	v	-	-	-	-	-	-	v	v	v	v	v	-	-	v	-	v	-	-	
	n7	-	-	-	v	-	-	-	-	-	-	v	v	v	v	v	-	-	v	-	v	-	-	
	n38	-	-	-	v	-	-	-	-	-	-	v	v	v	v	v	-	-	v	-	v	-	-	
26dB and 99% Bandwidth	n2	v	v	v	v	-	-	-	-	-	-	v	v	v	v	v	-	-	v	-	v	-	-	
	n7	v	v	v	v	-	-	-	-	-	-	v	v	v	v	v	-	-	v	-	v	-	-	
	n38	-	-	-	v	-	-	-	-	-	-	v	v	v	v	v	-	-	v	-	v	-	-	
Conducted Band Edge	n2	v	v	v	v	-	-	-	-	-	-	v	v	v	v	v	v	-	-	v	-	v	-	
	n7	v	v	v	v	-	-	-	-	-	-	v	v	v	v	v	v	-	-	v	-	v	-	
	n38	-	-	-	v	-	-	-	-	-	-	v	v	v	v	v	v	-	-	v	-	v	-	
Conducted Spurious Emission	n2	v	-	-	-	-	-	-	-	-	-	-	v	-	-	-	-	-	v	-	-	v	-	
	n7	v	-	-	-	-	-	-	-	-	-	-	v	-	-	-	-	-	v	-	-	v	-	
	n38	-	-	-	v	-	-	-	-	-	-	-	v	-	-	-	-	-	v	-	-	v	-	
Frequency Stability	n2	-	-	-	v	-	-	-	-	-	-	v	-	-	-	-	-	-	-	v	-	v	-	
	n7	-	-	-	v	-	-	-	-	-	-	v	-	-	-	-	-	-	-	v	-	v	-	
	n38	-	-	-	v	-	-	-	-	-	-	v	-	-	-	-	-	-	-	v	-	v	-	



Test Items	NR Band	Bandwidth (MHz)										Modulation					RB #			Test Channel			
		5	10	15	20	40	50	60	80	90	100	PI/2 BPSK	QPSK	16QAM	64QAM	256QAM	1	Half	Full	L	M	H	
E.R.P / E.I.R.P	n2	v	v	v	v	-	-	-	-	-	-	v	v	v	v	v	Max Power						
	n5	v	v	v	v	-	-	-	-	-	-	v	v	v	v	v							
	n7	v	v	v	v	-	-	-	-	-	-	v	v	v	v	v							
	n12	v	v	v	-	-	-	-	-	-	-	v	v	v	v	v							
	n25	v	v	v	v	-	-	-	-	-	-	v	v	v	v	v							
	n38	-			v							v	v	v	v	v							
	n41				v	v	v	v	v	v	v	v	v	v	v	v							
	n66	v	v	v	v	-	-	-	-	-	-	v	v	v	v	v							
n71	v	v	v	v	-	-	-	-	-	-	v	v	v	v	v								
Radiated Spurious Emission	n2	Worst Case														v	v	v					
	n5	Worst Case														v	v	v					
	n7	Worst Case														v	v	v					
	n12	Worst Case														v	v	v					
	n25	Worst Case														v	v	v					
	n38	Worst Case														v	v	v					
	n41	Worst Case														v	v	v					
	n66	Worst Case														v	v	v					
n71	Worst Case														v	v	v						
Remark	<ol style="list-style-type: none"> The mark "v" means that this configuration is chosen for testing The mark "-" means that this bandwidth is not supported. The device is investigated from 30MHz to 10 times of fundamental signal for radiated spurious emission test under different RB size/offset and modulations in exploratory test. Subsequently, only the worst case emissions are reported. Test combination is EN-DC 5A-n2A, EN-DC 66A-n2A, EN-DC 2A-n5A, EN-DC 7A-n5A, EN-DC 66A-n5A, EN-DC 5A-n7A, EN-DC 12A-n7A, EN-DC 66A-n7A, EN-DC 2A-n12A, EN-DC 66A-n12A, EN-DC 12A-n25A, EN-DC 5A-n38A, EN-DC 12A-n38A, EN-DC 71A-n38A, EN-DC 2A-n41A, EN-DC 4A-n41A, EN-DC 25A-n41A, EN-DC 26A-n41A, EN-DC 5A-n66A, EN-DC 7A-n66A, EN-DC 71A-n66A, EN-DC 7A-n71A. For radiated measurement, pre-scanned in two modes, DFT-s OFDM and CP OFDM. The worst cases (DFT-s OFDM) were recorded in this report, and the worst modes of FR1 and LTE for simultaneous transmission were verified and compliant. All the radiated test cases were performed with Battery 2. 																						

2.2 Connection Diagram of Test System

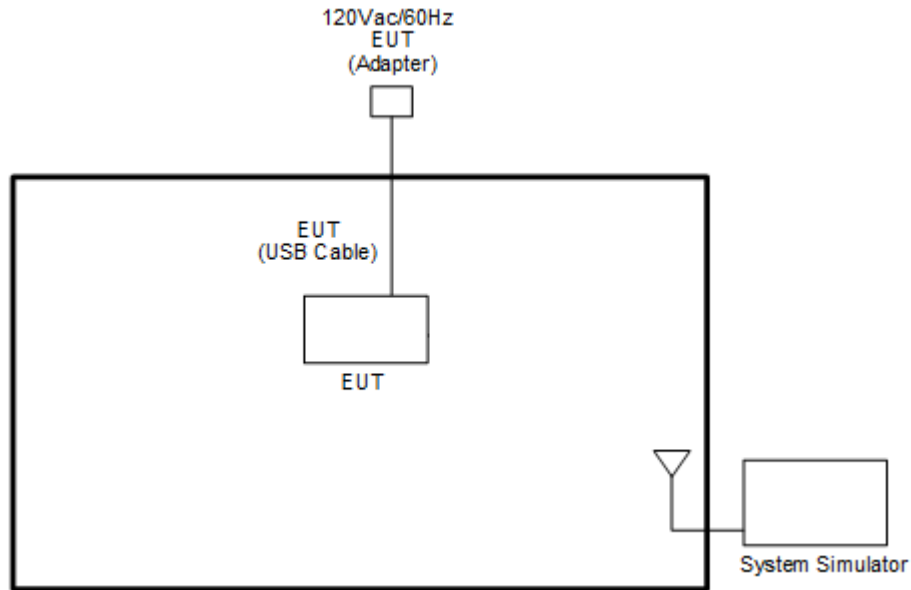

2.3 Support Unit used in test configuration and system

Item	Equipment	Brand Name	Model No.	FCC ID	Data Cable	Power Cord
1.	System Simulator	Anritsu	MT8821C	N/A	N/A	Unshielded, 1.8 m
2.	5G Wireless Test Platform	Anritsu	MT8000A	N/A	N/A	Unshielded, 1.8 m

2.4 Measurement Results Explanation Example

For all conducted test items:

The offset level is set in the spectrum analyzer to compensate the RF cable loss and attenuator factor between EUT conducted output port and spectrum analyzer. With the offset compensation, the spectrum analyzer reading level is exactly the EUT RF output level.

The spectrum analyzer offset is derived from RF cable loss and attenuator factor.

Offset = RF cable loss + attenuator factor.

Following shows an offset computation example with cable loss 4.2 dB and 10dB attenuator.

Example :

$$\begin{aligned} \text{Offset(dB)} &= \text{RF cable loss(dB)} + \text{attenuator factor(dB)}. \\ &= 4.2 + 10 = 14.2 \text{ (dB)} \end{aligned}$$



2.5 Frequency List of Low/Middle/High Channels

5G NR Band n2 Channel and Frequency List				
BW [MHz]	Channel/Frequency(MHz)	Lowest	Middle	Highest
20	Channel	372000	376000	380000
	Frequency	1860	1880	1900
15	Channel	371500	376000	380500
	Frequency	1857.5	1880	1902.5
10	Channel	371000	376000	381000
	Frequency	1855	1880	1905
5	Channel	370500	376000	381500
	Frequency	1852.5	1880	1907.5

5G NR n5 Channel and Frequency List				
BW [MHz]	Channel/Frequency(MHz)	Lowest	Middle	Highest
20	Channel	166800	167300	167800
	Frequency	834	836.5	839
15	Channel	166300	167300	168300
	Frequency	831.5	836.5	841.5
10	Channel	165800	167300	168800
	Frequency	829	836.5	844
5	Channel	165300	167300	169300
	Frequency	826.5	836.5	846.5

5G NR Band n7 Channel and Frequency List				
BW [MHz]	Channel/Frequency(MHz)	Lowest	Middle	Highest
20	Channel	502000	507000	512000
	Frequency	2510	2535	2560
15	Channel	501500	507000	512500
	Frequency	2507.5	2535	2562.5
10	Channel	501000	507000	513000
	Frequency	2505	2535	2565
5	Channel	500500	507000	513500
	Frequency	2502.5	2535	2567.5



5G NR n12 Channel and Frequency List				
BW [MHz]	Channel/Frequency(MHz)	Lowest	Middle	Highest
15	Channel	141300	141500	141700
	Frequency	706.5	707.5	708.5
10	Channel	140800	141500	142200
	Frequency	704	707.5	711
5	Channel	140300	141500	142700
	Frequency	701.5	707.5	713.5

5G NR Band n25 Channel and Frequency List				
BW [MHz]	Channel/Frequency(MHz)	Lowest	Middle	Highest
20	Channel	372000	376500	381000
	Frequency	1860	1882.5	1905
15	Channel	371500	376500	381500
	Frequency	1857.5	1882.5	1907.5
10	Channel	371000	376500	382000
	Frequency	1855	1882.5	1910
5	Channel	370500	376500	382500
	Frequency	1852.5	1882.5	1912.5

5G NR Band n38 Channel and Frequency List				
BW [MHz]	Channel/Frequency(MHz)	Lowest	Middle	Highest
20	Channel	516000	519000	522000
	Frequency	2580	2595	2610



5G NR Band n41 Channel and Frequency List				
BW [MHz]	Channel/Frequency(MHz)	Lowest	Middle	Highest
100	Channel	509202	518598	528000
	Frequency	2546.01	2592.99	2640
90	Channel	508200	518598	528996
	Frequency	2541	2592.99	2644.98
80	Channel	507204	518598	529998
	Frequency	2536.02	2592.99	2649.99
60	Channel	505200	518598	531996
	Frequency	2526	2592.99	2659.98
50	Channel	504204	518598	532998
	Frequency	2521.02	2592.99	2664.99
40	Channel	503202	518598	534000
	Frequency	2516.01	2592.99	2670
20	Channel	501204	518598	535998
	Frequency	2506.02	2592.99	2679.99

5G NR Band n66 Channel and Frequency List				
BW [MHz]	Channel/Frequency(MHz)	Lowest	Middle	Highest
20	Channel	344000	349000	354000
	Frequency	1720	1745	1770
15	Channel	343500	349000	354500
	Frequency	1717.5	1745	1772.5
10	Channel	343000	349000	355000
	Frequency	1715	1745	1775
5	Channel	342500	349000	355500
	Frequency	1712.5	1745	1777.5



5G NR Band n71 Channel and Frequency List				
BW [MHz]	Channel/Frequency(MHz)	Lowest	Middle	Highest
20	Channel	134600	136100	137600
	Frequency	673	680.5	688
15	Channel	134100	136100	138100
	Frequency	670.5	680.5	690.5
10	Channel	133600	136100	138600
	Frequency	668	680.5	693
5	Channel	133100	136100	139100
	Frequency	665.5	680.5	695.5

3 Conducted Test Items

3.1 Measuring Instruments

See list of measuring instruments of this test report.

3.1.1 Test Setup

3.1.2 Conducted Output Power

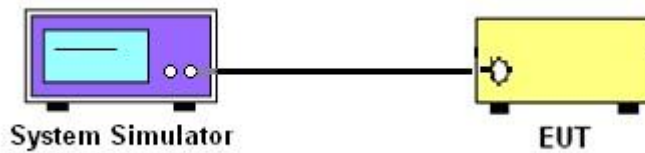

3.1.3 Peak-to-Average Ratio, Occupied Bandwidth ,Conducted Band-Edge and Conducted Spurious Emission

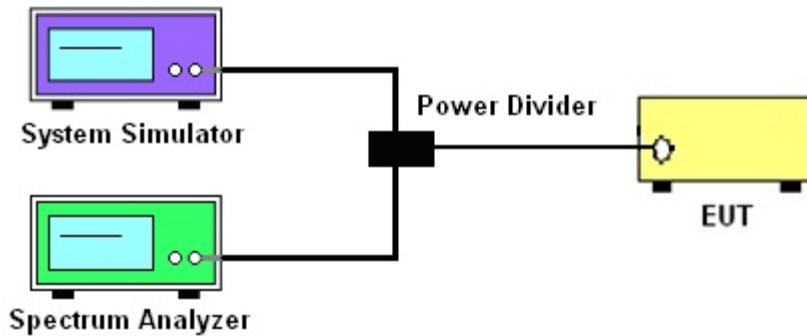

3.1.4 Frequency Stability

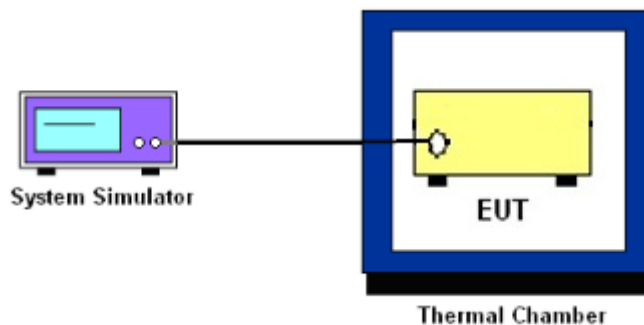

3.1.5 Test Result of Conducted Test

Please refer to Appendix A.



3.2 Conducted Output Power and ERP/EIRP

3.2.1 Description of the Conducted Output Power Measurement and ERP/EIRP Measurement

A system simulator was used to establish communication with the EUT. Its parameters were set to force the EUT transmitting at maximum output power. The measured power in the radio frequency on the transmitter output terminals shall be reported.

The ERP of mobile transmitters must not exceed 7 Watts for 5G NR n5

The ERP of mobile transmitters must not exceed 3 Watts for 5G NR n12 and n71

The EIRP of mobile transmitters must not exceed 2 Watts for 5G NR n2 and n25 and n7 and n38 and n41

The EIRP of mobile transmitters must not exceed 1 Watts for 5G NR n66

According to KDB 412172 D01 Power Approach,

$EIRP = P_T + G_T - L_C$, $ERP = EIRP - 2.15$, where

P_T = transmitter output power in dBm

G_T = gain of the transmitting antenna in dBi

L_C = signal attenuation in the connecting cable between the transmitter and antenna in dB

3.2.2 Test Procedures

1. The transmitter output port was connected to the system simulator.
2. Set EUT at maximum power through the system simulator.
3. Select lowest, middle, and highest channels for each band and different modulation.
4. Measure and record the power level from the system simulator.



3.3 Peak-to-Average Ratio

3.3.1 Description of the PAR Measurement

Power Complementary Cumulative Distribution Function (CCDF) curves provide a means for characterizing the power peaks of a digitally modulated signal on a statistical basis. A CCDF curve depicts the probability of the peak signal amplitude exceeding the average power level. Most contemporary measurement instrumentation include the capability to produce CCDF curves for an input signal provided that the instrument's resolution bandwidth can be set wide enough to accommodate the entire input signal bandwidth. In measuring transmissions in this band using an average power technique, the peak-to-average ratio (PAR) of the transmission may not exceed 13 dB.

3.3.2 Test Procedures

The testing follows ANSI C63.26-2015 Section 5.2.6

1. The EUT was connected to spectrum and system simulator via a power divider.
2. Set the CCDF (Complementary Cumulative Distribution Function) option in spectrum analyzer.
3. The highest RF powers were measured and recorded the maximum PAPR level associated with a probability of 0.1 %.
4. Record the deviation as Peak to Average Ratio.



3.4 Occupied Bandwidth

3.4.1 Description of Occupied Bandwidth Measurement

The occupied bandwidth is the width of a frequency band such that, below the lower and above the upper frequency limits, the mean powers emitted are each equal to a specified percentage 0.5% of the total mean transmitted power.

The 26 dB emission bandwidth is defined as the frequency range between two points, one above and one below the carrier frequency, at which the spectral density of the emission is attenuated 26 dB below the maximum in-band spectral density of the modulated signal. Spectral density (power per unit bandwidth) is to be measured with a detector of resolution bandwidth equal to approximately 1.0% of the emission bandwidth.

3.4.2 Test Procedures

The testing follows ANSI C63.26-2015 Section 5.4.3 (26dB) and Section 5.4.4 (99OB)

1. The EUT was connected to spectrum analyzer and system simulator via a power divider.
2. The spectrum analyzer center frequency is set to the nominal EUT channel center frequency. The span range for the spectrum analyzer shall be between two and five times the anticipated OBW.
3. The nominal resolution bandwidth (RBW) shall be in the range of 1 to 5 % of the anticipated OBW, and the VBW shall be at least 3 times the RBW.
4. Set the detection mode to peak, and the trace mode to max hold.
5. Determine the reference value: Set the EUT to transmit a modulated signal. Allow the trace to stabilize. Set the spectrum analyzer marker to the highest level of the displayed trace.
(this is the reference value)
6. Determine the “-26 dB down amplitude” as equal to (Reference Value – X).
7. Place two markers, one at the lowest and the other at the highest frequency of the envelope of the spectral display such that each marker is at or slightly below the “-X dB down amplitude” determined in step 6. If a marker is below this “-X dB down amplitude” value it shall be placed as close as possible to this value. The OBW is the positive frequency difference between the two markers.
8. Use the 99 % power bandwidth function of the spectrum analyzer and report the measured bandwidth.



3.5 Conducted Band Edge

3.5.1 Description of Conducted Band Edge Measurement

24.238 (a)

For operations in the 1850-1910 and 1930-1990 MHz band, the FCC limit is $43 + 10\log_{10}(P[\text{Watts}])$ dB below the transmitter power $P(\text{Watts})$ in a 1MHz bandwidth. However, in the 1 MHz bands immediately outside and adjacent to the frequency block a resolution bandwidth of at least one percent of the emission bandwidth of the fundamental emission of the transmitter may be employed.

27.53(m)(4)

For mobile digital stations, the attenuation factor shall be not less than $40 + 10 \log (P)$ dB on all frequencies between the channel edge and 5 megahertz from the channel edge, $43 + 10 \log (P)$ dB on all frequencies between 5 megahertz and X megahertz from the channel edge, and $55 + 10 \log (P)$ dB on all frequencies more than X megahertz from the channel edge, where X is the greater of 6 megahertz or the actual emission bandwidth as defined in paragraph (m)(6) of this section. In addition, the attenuation factor shall not be less that $43 + 10 \log (P)$ dB on all frequencies between 2490.5 MHz and 2496 MHz and $55 + 10 \log (P)$ dB at or below 2490.5 MHz. Mobile Satellite Service licensees operating on frequencies below 2495 MHz may also submit a documented interference complaint against BRS licensees operating on channel BRS Channel 1 on the same terms and conditions as adjacent channel BRS or EBS licensees.

3.5.2 Test Procedures

The testing follows FCC KDB 971168 D01 v03r01 Section 6.1.

1. The EUT was connected to spectrum analyzer and system simulator via a power divider.
2. The band edges of low and high channels for the highest RF powers were measured.
3. Set RBW $\geq 1\%$ EBW in the 1MHz band immediately outside and adjacent to the band edge.
4. Beyond the 1 MHz band from the band edge, RBW=1MHz was used.
5. Set spectrum analyzer with RMS detector.
6. The RF fundamental frequency should be excluded against the limit line in the operating frequency band.
7. Checked that all the results comply with the emission limit line.

The limit line is derived from $43 + 10\log(P)$ dB below the transmitter power $P(\text{Watts})$

For 5G NR n7, n38

The other 40 dB, and 55 dB have additionally applied same calculation above.



3.6 Conducted Spurious Emission

3.6.1 Description of Conducted Spurious Emission Measurement

The power of any emission outside of the authorized operating frequency ranges must be lower than the transmitter power (P) by a factor of at least $43 + 10 \log (P)$ dB.

For 5G NR n7, n38

The power of any emission outside of the authorized operating frequency ranges must be lower than the transmitter power (P) by a factor of at least $55 + 10 \log (P)$ dB.

It is measured by means of a calibrated spectrum analyzer and scanned from 30 MHz up to a frequency including its 10th harmonic.

3.6.2 Test Procedures

The testing follows FCC KDB 971168 D01 v03r01 Section 6.1.

1. The EUT was connected to spectrum analyzer and system simulator via a power divider.
2. The RF output of EUT was connected to the spectrum analyzer by RF cable and attenuator.
The path loss was compensated to the results for each measurement.
3. The middle channel for the highest RF power within the transmitting frequency was measured.
4. The conducted spurious emission for the whole frequency range was taken.
5. Make the measurement with the spectrum analyzer's RBW = 1MHz, VBW = 3MHz.
6. Set spectrum analyzer with RMS detector.
7. Taking the record of maximum spurious emission.
8. The RF fundamental frequency should be excluded against the limit line in the operating frequency band.
9. The limit line is derived from $43 + 10\log(P)$ dB below the transmitter power P(Watts)
For 5G NR n7, n38
The limit line is derived from $55 + 10\log(P)$ dB below the transmitter power P(Watts)



3.7 Frequency Stability

3.7.1 Description of Frequency Stability Measurement

24.235 & 27.54

The frequency stability shall be sufficient to ensure that the fundamental emission stays within the authorized frequency block.

3.7.2 Test Procedures for Temperature Variation

The testing follows FCC KDB 971168 D01 v03r01 Section 9.0.

1. The EUT was set up in the thermal chamber and connected with the system simulator.
2. With power OFF, the temperature was decreased to -30°C and the EUT was stabilized before testing. Power was applied and the maximum change in frequency was recorded within one minute.
3. With power OFF, the temperature was raised in 10°C step up to 50°C . The EUT was stabilized at each step for at least half an hour. Power was applied and the maximum frequency change was recorded within one minute.

3.7.3 Test Procedures for Voltage Variation

The testing follows FCC KDB 971168 D01 v03r01 Section 9.0.

1. The EUT was placed in a temperature chamber at $20\pm 5^{\circ}\text{C}$ and connected with the system simulator.
2. The power supply voltage to the EUT was varied from 85% to 115% of the nominal value measured at the input to the EUT.
3. The variation in frequency was measured for the worst case.

4 Radiated Test Items

4.1 Measuring Instruments

See list of measuring instruments of this test report.

4.1.1 Test Setup

For radiated emissions below 30MHz

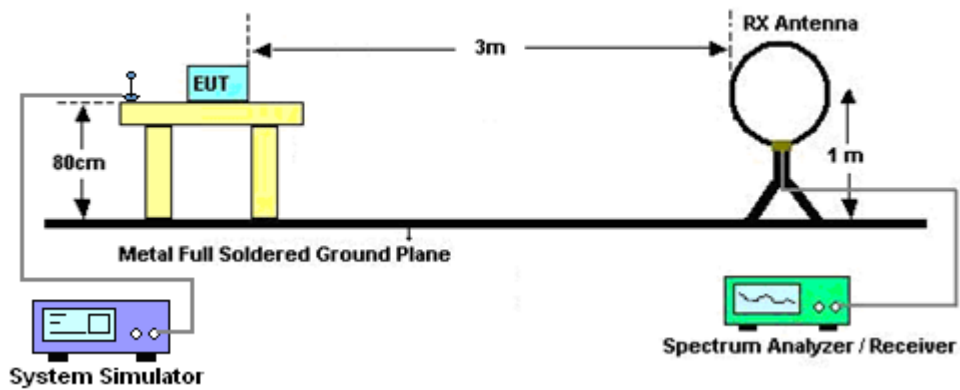

For radiated test from 30MHz to 1GHz

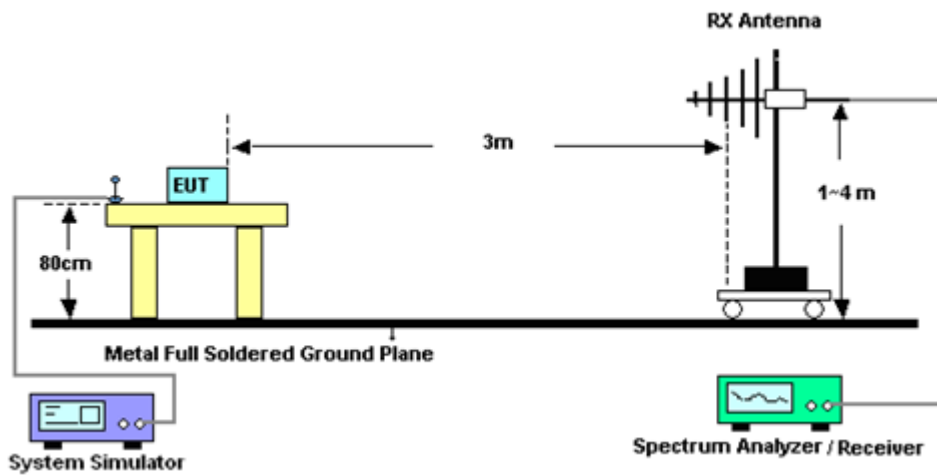

For radiated test from 1GHz to 18GHz

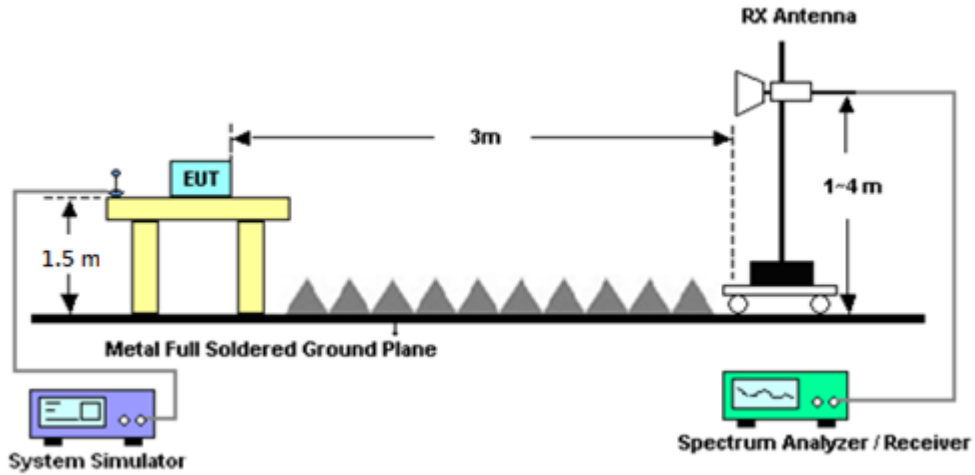

For radiated test above 18GHz

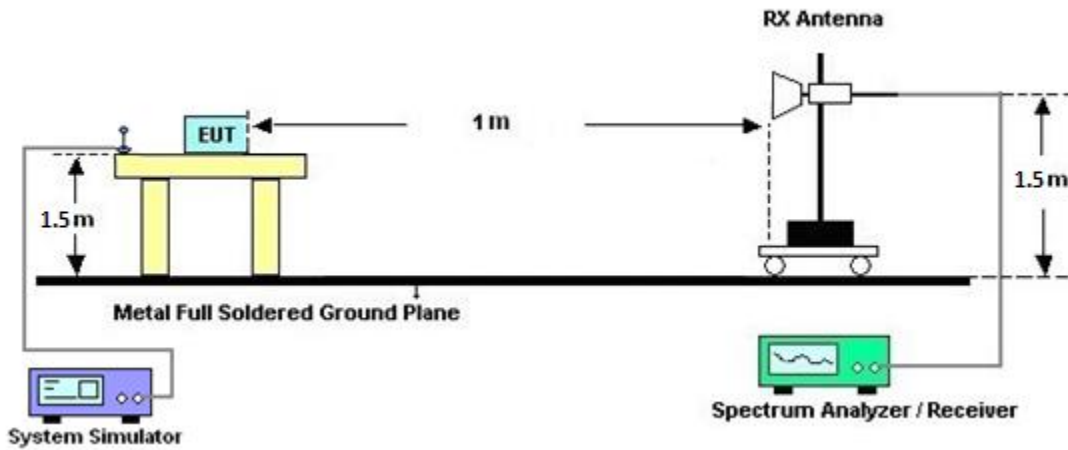

4.1.2 Test Result of Radiated Test

Please refer to Appendix B.

Note:

The low frequency, which started from 9 kHz to 30MHz, was pre-scanned and the result which was 20dB lower than the limit line was not reported.

There is a comparison data of both open-field test site and alternative test site - semi-Anechoic chamber according to 414788 D01 Radiated Test Site v01r01, and the result came out very similar.



4.2 Radiated Spurious Emission Measurement

4.2.1 Description of Radiated Spurious Emission Measurement

The radiated spurious emission was measured by substitution method according to ANSI / TIA-603-E. The power of any emission outside of the authorized operating frequency ranges must be attenuated below the transmitter power (P) by a factor of at least $43 + 10 \log (P)$ dB.

For 5G NR n7, n38, n41

The power of any emission outside of the authorized operating frequency ranges must be attenuated below the transmitter power (P) by a factor of at least $55 + 10 \log (P)$ dB.

The spectrum is scanned from 30 MHz up to a frequency including its 10th harmonic.

4.2.2 Test Procedures

The testing follows FCC KDB 971168 D01 v03r01 Section 7 and ANSI / TIA-603-E Section 2.2.12.

1. The EUT was placed on a turntable with 0.8 meter for frequency below 1GHz and 1.5 meter for frequency above 1GHz respectively above ground.
2. The EUT was set 3 meters from the receiving antenna, which was mounted on the antenna tower.
3. The table was rotated 360 degrees to determine the position of the highest spurious emission.
4. The height of the receiving antenna is varied between one meter and four meters to search the maximum spurious emission for both horizontal and vertical polarizations.
5. Make the measurement with the spectrum analyzer's RBW = 1MHz, VBW = 3MHz, taking the record of maximum spurious emission.
6. A horn antenna was substituted in place of the EUT and was driven by a signal generator.
7. Tune the output power of signal generator to the same emission level with EUT maximum spurious emission.
8. Taking the record of output power at antenna port.
9. Repeat step 7 to step 8 for another polarization.
10. The RF fundamental frequency should be excluded against the limit line in the operating frequency band.

The limit line is derived from $43 + 10\log(P)$ dB below the transmitter power P(Watts)

For 5G NR n7, n38, n41

The limit line is derived from $55 + 10\log(P)$ dB below the transmitter power P(Watts)



5 List of Measuring Equipment

Instrument	Brand Name	Model No.	Serial No.	Characteristics	Calibration Date	Test Date	Due Date	Remark
Loop Antenna	Rohde & Schwarz	HFH2-Z2	100315	9 kHz~30 MHz	Jan. 04, 2021	Feb. 12, 2021~ Mar. 27, 2021	Jan. 03, 2022	Radiation (03CH12-HY)
Bilog Antenna	TESEQ	CBL 6111D & 00800N1D01N -06	40103 & 07	30MHz~1GHz	Apr. 29, 2020	Feb. 12, 2021~ Mar. 27, 2021	Apr. 28, 2021	Radiation (03CH12-HY)
Horn Antenna	SCHWARZBE CK	BBHA 9120 D	9120D-1328	1GHz~18GHz	Nov. 23, 2020	Feb. 12, 2021~ Mar. 27, 2021	Nov. 22, 2021	Radiation (03CH12-HY)
Horn Antenna	SCHWARZBE CK	BBHA 9120 D	9120D-1212	1GHz~18GHz	May 20, 2020	Feb. 12, 2021~ Mar. 27, 2021	May 19, 2021	Radiation (03CH12-HY)
SHF-EHF Horn Antenna	SCHWARZBE CK	BBHA 9170	00993	18GHz~40GHz	Dec. 19, 2020	Feb. 12, 2021~ Mar. 27, 2021	Dec. 18, 2021	Radiation (03CH12-HY)
SHF-EHF Horn Antenna	SCHWARZBE CK	BBHA 9170	BBHA917057 6	18GHz~40GHz	May 22, 2020	Feb. 12, 2021~ Mar. 27, 2021	May 21, 2021	Radiation (03CH12-HY)
Preamplifier	COM-POWER	PA-103	161075	10MHz~1GHz	Mar. 25, 2020	Feb. 12, 2021~ Mar. 23, 2021	Mar. 24, 2021	Radiation (03CH12-HY)
Preamplifier	COM-POWER	PA-103	161075	10MHz~1GHz	Mar. 24, 2021	Mar. 24, 2021~ Mar. 27, 2021	Mar. 23, 2022	Radiation (03CH12-HY)
Preamplifier	Keysight	83017A	MY57280120	1GHz~26.5GHz	Jul. 20, 2020	Feb. 12, 2021~ Mar. 27, 2021	Jul. 19, 2021	Radiation (03CH12-HY)
Preamplifier	E-INSTRUME NT TECH LTD.	ERA-100M-18 G-56-01-A70	EC1900249	1GHz-18GHz	Dec. 05, 2020	Feb. 12, 2021~ Mar. 27, 2021	Dec. 04, 2021	Radiation (03CH12-HY)
Preamplifier	EMEC	EM18G40G	060715	18GHz~40GHz	Dec. 11, 2020	Feb. 12, 2021~ Mar. 27, 2021	Dec. 10, 2021	Radiation (03CH12-HY)
Spectrum Analyzer	Agilent	N9010A	MY53470118	10Hz~44GHz	Jan. 15, 2021	Feb. 12, 2021~ Mar. 27, 2021	Jan. 14, 2022	Radiation (03CH12-HY)
RF Cable	HUBER + SUHNER	SUCOFLEX 104	MY9837/4PE	9kHz~30MHz	Mar. 12, 2020	Feb. 12, 2021~ Mar. 10, 2021	Mar. 11, 2021	Radiation (03CH12-HY)
RF Cable	HUBER + SUHNER	SUCOFLEX 104	MY9837/4PE	9kHz~30MHz	Mar. 11, 2021	Mar. 11, 2021~ Mar. 27, 2021	Mar. 10, 2022	Radiation (03CH12-HY)
RF Cable	HUBER + SUHNER	SUCOFLEX 126E	0058/126E	30MHz~18GHz	Dec. 11, 2020	Feb. 12, 2021~ Mar. 27, 2021	Dec. 10, 2021	Radiation (03CH12-HY)
RF Cable	HUBER + SUHNER	SUCOFLEX 102	505134/2	30MHz~40GHz	Feb. 25, 2020	Feb. 12, 2021~ Feb. 21, 2021	Feb. 24, 2021	Radiation (03CH12-HY)
RF Cable	HUBER + SUHNER	SUCOFLEX 102	505134/2	30MHz~40GHz	Feb. 22, 2021	Feb. 22, 2021~ Mar. 27, 2021	Feb. 21, 2022	Radiation (03CH12-HY)
RF Cable	HUBER + SUHNER	SUCOFLEX 102	800740/2	30MHz~40GHz	Feb. 25, 2020	Feb. 12, 2021~ Feb. 21, 2021	Feb. 24, 2021	Radiation (03CH12-HY)
RF Cable	HUBER + SUHNER	SUCOFLEX 102	800740/2	30MHz~40GHz	Feb. 22, 2021	Feb. 22, 2021~ Mar. 27, 2021	Feb. 21, 2022	Radiation (03CH12-HY)
Antenna Mast	EMEC	AM-BS-4500-B	N/A	1m~4m	N/A	Feb. 12, 2021~ Mar. 27, 2021	N/A	Radiation (03CH12-HY)
Turn Table	EMEC	TT2000	N/A	0~360 Degree	N/A	Feb. 12, 2021~ Mar. 27, 2021	N/A	Radiation (03CH12-HY)
Software	Audix	E3 6.2009-8-24	RK-000989	N/A	N/A	Feb. 12, 2021~ Mar. 27, 2021	N/A	Radiation (03CH12-HY)



Instrument	Brand Name	Model No.	Serial No.	Characteristics	Calibration Date	Test Date	Due Date	Remark
Filter	Wainwright	WLKS1200-12 SS	SN2	1.2GHz Low Pass Filter	Mar. 21, 2020	Feb. 12, 2021~ Mar. 16, 2021	Mar. 20, 2021	Radiation (03CH12-HY)
Filter	Wainwright	WLKS1200-12 SS	SN2	1.2GHz Low Pass Filter	Mar. 17, 2021	Mar. 17, 2021~ Mar. 27, 2021	Mar. 16, 2022	Radiation (03CH12-HY)
Filter	Wainwright	WHKX12-2700 -3000-18000-6 0ST	SN2	3GHz High Pass Filter	Jul. 14, 2020	Feb. 12, 2021~ Mar. 27, 2021	Jul. 13, 2021	Radiation (03CH12-HY)
Filter	Wainwright	WHKX8-5872. 5-6750-18000- 40ST	SN2	6.75GHz High Pass Filter	Mar. 18, 2020	Feb. 12, 2021~ Mar. 16, 2021	Mar. 17, 2021	Radiation (03CH12-HY)
Filter	Wainwright	WHKX8-5872. 5-6750-18000- 40ST	SN2	6.75GHz High Pass Filter	Mar. 17, 2021	Mar. 17, 2021~ Mar. 27, 2021	Mar. 16, 2022	Radiation (03CH12-HY)
Programmable Power Supply	GW Instek	PSS-2005	EL890001	50Hz~60Hz	Oct. 05, 2020	Mar. 03, 2021~ Mar. 30, 2021	Oct. 04, 2021	Conducted (TH05-HY)
Signal Analyzer	Rohde & Schwarz	FSV40	101907	10Hz~40GHz	May 14, 2020	Mar. 03, 2021~ Mar. 30, 2021	May 13, 2021	Conducted (TH05-HY)
Temperature Chamber	ESPEC	SU-241	92003713	-30℃ ~95℃	May 15, 2020	Mar. 03, 2021~ Mar. 30, 2021	May 14, 2021	Conducted (TH05-HY)
Hygrometer	Testo	34893241	608-H1	NA	Mar. 03, 2021	Mar. 03, 2021~ Mar. 30, 2021	Mar. 02, 2022	Conducted (TH05-HY)
Base Station (Measure)	Anritsu	MT8821C	6261849015	LTE	Sep. 18, 2020	Mar. 03, 2021~ Mar. 30, 2021	Sep. 17, 2021	Conducted (TH05-HY)
Base Station (Measure)	Anritsu	MT8000A	6261940327	FR1	Sep. 23, 2020	Mar. 03, 2021~ Mar. 30, 2021	Sep. 22, 2021	Conducted (TH05-HY)



6 Uncertainty of Evaluation

Uncertainty of Radiated Emission Measurement (30 MHz ~ 1000 MHz)

Measuring Uncertainty for a Level of Confidence of 95% ($U = 2Uc(y)$)	3.07
---	------

Uncertainty of Radiated Emission Measurement (1 GHz ~ 18 GHz)

Measuring Uncertainty for a Level of Confidence of 95% ($U = 2Uc(y)$)	3.21
---	------

Uncertainty of Radiated Emission Measurement (18 GHz ~ 40 GHz)

Measuring Uncertainty for a Level of Confidence of 95% ($U = 2Uc(y)$)	3.80
---	------



Appendix A. Test Results of Conducted Test

Conducted Output Power(Average power) and ERP/EIRP

NR n2 Maximum Average Power [dBm] (GT - LC = 3.6 dB)										
BW [MHz]	RB Size	RB Offset	Mod	Lowest	Middle	Highest	EIRP (dBm)	EIRP(W)		
5	1	1	PI/2 BPSK	20.86	20.63	20.61	24.53	0.2838		
5	1	23		20.93	20.71	20.64				
5	12	6		20.89	20.74	20.71				
5	1	0		20.31	20.16	20.10				
5	1	24		20.45	20.17	20.14				
5	25	0		20.40	20.22	20.17				
5	1	1	QPSK	20.84	20.62	20.64			23.75	0.2371
5	1	23		20.89	20.64	20.68				
5	12	6		20.91	20.69	20.63				
5	1	0		19.88	19.65	19.59				
5	1	24		19.85	19.65	19.65				
5	25	0		19.89	19.69	19.63				
5	1	1	16-QAM	20.15	19.54	19.99	23.75	0.2371		
5	1	1	64-QAM	18.03	18.33	17.80				
5	1	1	256-QAM	15.66	15.56	15.56				
Limit	EIRP < 2W			Result			Pass			

NR n2 Maximum Average Power [dBm] (GT - LC = 3.6 dB)										
BW [MHz]	RB Size	RB Offset	Mod	Lowest	Middle	Highest	EIRP (dBm)	EIRP(W)		
10	1	1	PI/2 BPSK	20.88	20.74	20.56	24.55	0.2851		
10	1	50		20.89	20.68	20.69				
10	25	12		20.93	20.67	20.64				
10	1	0		20.41	20.15	20.14				
10	1	51		20.38	20.11	20.17				
10	50	0		20.47	20.24	20.15				
10	1	1	QPSK	20.87	20.71	20.65			23.63	0.2307
10	1	50		20.95	20.72	20.63				
10	25	12		20.94	20.72	20.63				
10	1	0		19.78	19.72	19.63				
10	1	51		19.85	19.68	19.68				
10	50	0		19.94	19.68	19.64				
10	1	1	16-QAM	19.82	20.03	19.66	23.63	0.2307		
10	1	1	64-QAM	18.55	17.84	18.30				
10	1	1	256-QAM	15.87	15.56	15.55				
Limit	EIRP < 2W			Result			Pass			



NR n2 Maximum Average Power [dBm] (GT - LC = 3.6 dB)								
BW [MHz]	RB Size	RB Offset	Mod	Lowest	Middle	Highest	EIRP (dBm)	EIRP(W)
15	1	1	PI/2 BPSK	20.94	20.72	20.65	24.54	0.2844
15	1	77		20.83	20.78	20.76		
15	36	18		20.91	20.72	20.68		
15	1	0		20.44	20.20	20.10		
15	1	78		20.53	20.24	20.11		
15	75	0		20.43	20.23	20.25		
15	1	1	QPSK	20.93	20.72	20.57	24.54	0.2844
15	1	77		20.94	20.91	20.67		
15	36	18		20.93	20.74	20.68		
15	1	0		19.90	19.78	19.59		
15	1	78		20.03	19.77	19.68		
15	75	0		19.98	19.69	19.62		
15	1	1	16-QAM	20.13	19.67	19.95	23.73	0.236
15	1	1	64-QAM	18.03	18.38	17.78		
15	1	1	256-QAM	15.83	15.85	15.77		
Limit	EIRP < 2W			Result			Pass	

NR n2 Maximum Average Power [dBm] (GT - LC = 3.6 dB)								
BW [MHz]	RB Size	RB Offset	Mod	Lowest	Middle	Highest	EIRP (dBm)	EIRP(W)
20	1	1	PI/2 BPSK	20.96	20.83	20.72	24.56	0.2858
20	1	104		20.90	20.79	20.69		
20	50	25		20.94	20.75	20.76		
20	1	0		20.50	20.24	20.19		
20	1	105		20.44	20.21	20.20		
20	100	0		20.44	20.27	20.23		
20	1	1	QPSK	20.93	20.72	20.66	24.56	0.2858
20	1	104		20.94	20.66	20.73		
20	50	25		20.92	20.79	20.68		
20	1	0		19.94	19.74	19.74		
20	1	105		19.96	19.66	19.80		
20	100	0		19.92	19.81	19.77		
20	1	1	16-QAM	19.58	19.66	19.78	23.38	0.2178
20	1	1	64-QAM	18.23	18.46	18.55		
20	1	1	256-QAM	15.81	15.64	15.59		
Limit	EIRP < 2W			Result			Pass	



NR n5 Maximum Average Power [dBm] (GT - LC = 0.2 dB)								
BW [MHz]	RB Size	RB Offset	Mod	Lowest	Middle	Highest	ERP (dBm)	ERP(W)
5	1	1	PI/2 BPSK	23.68	23.41	23.17	21.73	0.1489
5	1	23		23.40	23.20	23.02		
5	12	6		23.58	23.32	23.13		
5	1	0		23.05	22.90	22.62		
5	1	24		22.86	22.68	22.39		
5	25	0		22.97	22.82	22.58		
5	1	1	QPSK	23.64	23.40	23.16		
5	1	23		23.62	23.28	23.14		
5	12	6		23.54	23.28	23.00		
5	1	0		22.48	22.45	22.19		
5	1	24		22.48	22.29	21.90		
5	25	0		22.49	22.31	22.04		
5	1	1	16-QAM	22.56	22.32	22.15	20.61	0.1151
5	1	1	64-QAM	21.24	21.04	20.77		
5	1	1	256-QAM	18.53	18.30	18.16		
Limit	ERP < 7W			Result			Pass	

NR n5 Maximum Average Power [dBm] (GT - LC = 0.2 dB)								
BW [MHz]	RB Size	RB Offset	Mod	Lowest	Middle	Highest	ERP (dBm)	ERP(W)
10	1	1	PI/2 BPSK	23.55	23.52	23.31	21.66	0.1466
10	1	50		23.59	23.38	23.09		
10	25	12		23.61	23.48	23.26		
10	1	0		23.08	23.02	22.75		
10	1	51		23.00	22.75	22.55		
10	50	0		23.08	22.99	22.78		
10	1	1	QPSK	23.54	23.49	23.25		
10	1	50		23.58	23.35	23.07		
10	25	12		23.60	23.46	23.20		
10	1	0		22.39	22.46	22.42		
10	1	51		22.48	22.34	22.06		
10	50	0		22.55	22.43	22.18		
10	1	1	16-QAM	22.56	22.44	22.16	20.61	0.1151
10	1	1	64-QAM	21.16	21.12	20.94		
10	1	1	256-QAM	18.43	18.40	18.28		
Limit	ERP < 7W			Result			Pass	



NR n5 Maximum Average Power [dBm] (GT - LC = 0.2 dB)								
BW [MHz]	RB Size	RB Offset	Mod	Lowest	Middle	Highest	ERP (dBm)	ERP(W)
15	1	1	PI/2 BPSK	23.63	23.66	23.44	21.71	0.1483
15	1	77		23.45	23.37	23.20		
15	36	18		23.55	23.56	23.37		
15	1	0		23.06	23.10	22.88		
15	1	78		22.89	22.85	22.63		
15	75	0		23.02	23.01	22.84		
15	1	1	QPSK	23.61	23.63	23.48		
15	1	77		23.41	23.33	23.29		
15	36	18		23.53	23.55	23.34		
15	1	0		22.69	22.40	22.32		
15	1	78		22.48	22.38	22.14		
15	75	0		22.56	22.54	22.36		
15	1	1	16-QAM	22.54	22.57	22.41	20.62	0.1153
15	1	1	64-QAM	21.21	21.25	21.14		
15	1	1	256-QAM	18.54	18.57	18.44		
Limit	ERP < 7W			Result			Pass	

NR n5 Maximum Average Power [dBm] (GT - LC = 0.2 dB)								
BW [MHz]	RB Size	RB Offset	Mod	Lowest	Middle	Highest	ERP (dBm)	ERP(W)
20	1	1	PI/2 BPSK	23.68	23.67	23.69	21.74	0.1493
20	1	104		23.42	23.34	23.32		
20	50	25		23.59	23.58	23.60		
20	1	0		23.16	23.20	23.17		
20	1	105		22.89	22.88	22.80		
20	100	0		23.05	23.10	23.02		
20	1	1	QPSK	23.64	23.65	23.67		
20	1	104		23.44	23.35	23.43		
20	50	25		23.63	23.60	23.56		
20	1	0		22.77	22.69	22.62		
20	1	105		22.51	22.35	22.44		
20	100	0		22.62	22.64	22.55		
20	1	1	16-QAM	22.62	22.67	22.63	20.72	0.1180
20	1	1	64-QAM	21.30	21.34	21.32		
20	1	1	256-QAM	18.68	18.71	18.60		
Limit	ERP < 7W			Result			Pass	



NR n7 Maximum Average Power [dBm] (GT - LC = 2.9 dB)								
BW [MHz]	RB Size	RB Offset	Mod	Lowest	Middle	Highest	EIRP (dBm)	EIRP(W)
5	1	1	PI/2 BPSK	23.79	23.80	23.74	26.77	0.4753
5	1	23		23.73	23.80	23.76		
5	12	6		23.77	23.80	23.78		
5	1	0		23.23	23.33	23.24		
5	1	24		23.26	23.30	23.24		
5	25	0		23.32	23.36	23.30		
5	1	1	QPSK	23.81	23.85	23.79		
5	1	23		23.77	23.87	23.75		
5	12	6		23.72	23.75	23.76		
5	1	0		22.82	22.81	22.76		
5	1	24		22.76	22.80	22.79		
5	25	0		22.81	22.85	22.83		
5	1	1	16-QAM	22.75	23.21	22.70	26.11	0.4083
5	1	1	64-QAM	21.44	21.01	21.48		
5	1	1	256-QAM	18.90	18.86	18.89		
Limit	EIRP < 2W			Result			Pass	

NR n7 Maximum Average Power [dBm] (GT - LC = 2.9 dB)								
BW [MHz]	RB Size	RB Offset	Mod	Lowest	Middle	Highest	EIRP (dBm)	EIRP(W)
10	1	1	PI/2 BPSK	23.76	23.77	23.77	26.79	0.4775
10	1	50		23.73	23.75	23.74		
10	25	12		23.89	23.79	23.82		
10	1	0		23.26	23.31	23.29		
10	1	51		23.23	23.25	23.27		
10	50	0		23.32	23.40	23.32		
10	1	1	QPSK	23.77	23.85	23.79		
10	1	50		23.71	23.68	23.74		
10	25	12		23.82	23.80	23.83		
10	1	0		22.91	22.84	22.78		
10	1	51		22.81	22.70	22.77		
10	50	0		22.83	22.81	22.81		
10	1	1	16-QAM	22.73	22.84	23.09	25.99	0.3972
10	1	1	64-QAM	21.49	21.51	20.92		
10	1	1	256-QAM	18.92	18.89	18.76		
Limit	EIRP < 2W			Result			Pass	



NR n7 Maximum Average Power [dBm] (GT - LC = 2.9 dB)								
BW [MHz]	RB Size	RB Offset	Mod	Lowest	Middle	Highest	EIRP (dBm)	EIRP(W)
15	1	1	PI/2 BPSK	23.91	23.94	22.70	26.84	0.4831
15	1	77		23.85	23.66	23.72		
15	36	18		23.90	23.93	23.74		
15	1	0		23.35	23.53	23.11		
15	1	78		23.32	23.23	23.19		
15	75	0		23.41	23.44	23.22		
15	1	1	QPSK	23.88	23.93	23.69		
15	1	77		23.87	23.62	23.75		
15	36	18		23.92	23.92	23.73		
15	1	0		22.78	23.07	22.75		
15	1	78		22.86	22.75	22.66		
15	75	0		22.92	22.90	22.74		
15	1	1	16-QAM	22.88	23.06	22.75	25.96	0.3945
15	1	1	64-QAM	21.56	21.65	21.47		
15	1	1	256-QAM	18.87	18.97	18.66		
Limit	EIRP < 2W			Result			Pass	

NR n7 Maximum Average Power [dBm] (GT - LC = 2.9 dB)								
BW [MHz]	RB Size	RB Offset	Mod	Lowest	Middle	Highest	EIRP (dBm)	EIRP(W)
20	1	1	PI/2 BPSK	23.82	23.95	23.75	26.85	0.4842
20	1	104		23.76	23.53	23.71		
20	50	25		23.81	23.93	23.80		
20	1	0		23.25	23.41	23.15		
20	1	105		23.27	23.19	23.23		
20	100	0		23.22	23.39	23.27		
20	1	1	QPSK	23.75	23.93	23.74		
20	1	104		23.74	23.67	23.67		
20	50	25		23.76	23.92	23.78		
20	1	0		22.76	23.08	22.64		
20	1	105		22.94	22.67	22.66		
20	100	0		22.72	22.92	22.78		
20	1	1	16-QAM	22.64	22.75	22.65	25.65	0.3673
20	1	1	64-QAM	21.41	21.46	21.43		
20	1	1	256-QAM	18.62	18.84	18.59		
Limit	EIRP < 2W			Result			Pass	



NR n12 Maximum Average Power [dBm] (GT - LC = 0.2 dB)								
BW [MHz]	RB Size	RB Offset	Mod	Lowest	Middle	Highest	ERP (dBm)	ERP(W)
5	1	1	PI/2 BPSK	22.36	22.35	22.22	20.42	0.1102
5	1	23		22.24	22.34	22.12		
5	12	6		22.26	22.32	22.25		
5	1	0		21.86	21.82	21.76		
5	1	24		21.72	21.76	21.53		
5	25	0		21.83	21.76	21.75		
5	1	1	QPSK	22.37	22.37	22.14	20.42	0.1102
5	1	23		22.27	22.31	22.12		
5	12	6		22.24	22.29	22.17		
5	1	0		21.46	21.31	21.26		
5	1	24		21.31	21.29	21.18		
5	25	0		21.30	21.26	21.23		
5	1	1	16-QAM	21.12	21.18	21.37	19.42	0.0875
5	1	1	64-QAM	19.86	19.95	19.45		
5	1	1	256-QAM	17.40	17.33	17.21		
Limit	ERP < 3W			Result			Pass	

NR n12 Maximum Average Power [dBm] (GT - LC = 0.2 dB)								
BW [MHz]	RB Size	RB Offset	Mod	Lowest	Middle	Highest	ERP (dBm)	ERP(W)
10	1	1	PI/2 BPSK	22.28	22.25	22.21	20.41	0.1099
10	1	50		22.24	22.23	22.12		
10	25	12		22.24	22.36	22.27		
10	1	0		21.81	21.86	21.71		
10	1	51		21.74	21.78	21.66		
10	50	0		21.81	21.93	21.84		
10	1	1	QPSK	22.33	22.27	22.16	20.41	0.1099
10	1	50		22.26	22.26	22.18		
10	25	12		22.23	22.34	22.30		
10	1	0		21.32	21.33	21.24		
10	1	51		21.22	21.30	21.15		
10	50	0		21.28	21.35	21.29		
10	1	1	16-QAM	21.25	21.16	21.55	19.60	0.0912
10	1	1	64-QAM	19.55	19.94	19.31		
10	1	1	256-QAM	17.28	17.34	17.23		
Limit	ERP < 3W			Result			Pass	



NR n12 Maximum Average Power [dBm] (GT - LC = 0.2 dB)								
BW [MHz]	RB Size	RB Offset	Mod	Lowest	Middle	Highest	ERP (dBm)	ERP(W)
15	1	1	PI/2 BPSK	22.38	22.35	22.33	20.43	0.1104
15	1	77		22.33	22.23	22.26		
15	36	18		22.27	22.28	22.30		
15	1	0		21.96	22.00	21.96		
15	1	78		21.78	21.80	21.72		
15	75	0		21.95	21.88	21.89		
15	1	1	QPSK	22.37	22.36	22.34	20.43	0.1104
15	1	77		22.35	22.28	22.30		
15	36	18		22.27	22.30	22.32		
15	1	0		21.54	21.50	21.50		
15	1	78		21.34	21.26	21.32		
15	75	0		21.43	21.42	21.41		
15	1	1	16-QAM	21.53	21.43	21.41	19.58	0.0908
15	1	1	64-QAM	20.26	20.16	20.22		
15	1	1	256-QAM	17.51	17.46	17.43		
Limit	ERP < 3W			Result			Pass	



NR n25 Maximum Average Power [dBm] (GT - LC = 0.9 dB)								
BW [MHz]	RB Size	RB Offset	Mod	Lowest	Middle	Highest	EIRP (dBm)	EIRP(W)
5	1	1	PI/2 BPSK	22.12	21.92	22.12	23.15	0.2065
5	1	23		22.07	22.14	22.11		
5	12	6		22.21	22.02	22.25		
5	1	0		21.67	21.49	21.71		
5	1	24		21.63	21.63	21.65		
5	25	0		21.69	21.62	21.76		
5	1	1	QPSK	22.08	21.81	22.08		
5	1	23		22.02	22.01	22.06		
5	12	6		22.15	22.01	22.15		
5	1	0		21.15	20.96	21.20		
5	1	24		21.13	21.09	21.13		
5	25	0		21.20	21.12	21.25		
5	1	1	16-QAM	21.21	21.04	21.29	22.19	0.1656
5	1	1	64-QAM	19.62	19.37	19.62		
5	1	1	256-QAM	17.30	17.09	17.32		
Limit	EIRP < 2W			Result			Pass	

NR n25 Maximum Average Power [dBm] (GT - LC = 0.9 dB)								
BW [MHz]	RB Size	RB Offset	Mod	Lowest	Middle	Highest	EIRP (dBm)	EIRP(W)
10	1	1	PI/2 BPSK	22.27	21.96	22.14	23.29	0.2133
10	1	50		22.10	22.09	22.11		
10	25	12		22.34	22.04	22.39		
10	1	0		21.87	21.54	21.82		
10	1	51		21.78	21.69	21.78		
10	50	0		21.86	21.61	21.90		
10	1	1	QPSK	22.16	21.83	22.09		
10	1	50		22.06	22.05	22.03		
10	25	12		22.27	21.98	22.27		
10	1	0		21.28	20.93	21.21		
10	1	51		21.19	21.14	21.22		
10	50	0		21.36	21.09	21.31		
10	1	1	16-QAM	21.41	21.04	21.30	22.31	0.1702
10	1	1	64-QAM	19.73	19.38	19.62		
10	1	1	256-QAM	17.42	17.10	17.36		
Limit	EIRP < 2W			Result			Pass	



NR n25 Maximum Average Power [dBm] (GT - LC = 0.9 dB)								
BW [MHz]	RB Size	RB Offset	Mod	Lowest	Middle	Highest	EIRP (dBm)	EIRP(W)
15	1	1	PI/2 BPSK	22.43	22.18	22.49	23.39	0.2183
15	1	77		22.19	22.20	22.33		
15	36	18		22.39	22.18	22.35		
15	1	0		21.97	21.72	22.05		
15	1	78		21.79	21.79	21.85		
15	75	0		21.96	21.76	21.92		
15	1	1	QPSK	22.38	22.09	22.42		
15	1	77		22.16	22.13	22.24		
15	36	18		22.37	22.16	22.32		
15	1	0		21.43	21.17	21.46		
15	1	78		21.21	21.25	21.30		
15	75	0		21.46	21.30	21.49		
15	1	1	16-QAM	21.63	21.34	21.66	22.56	0.1803
15	1	1	64-QAM	19.97	19.59	19.90		
15	1	1	256-QAM	17.61	17.36	17.66		
Limit	EIRP < 2W			Result			Pass	

NR n25 Maximum Average Power [dBm] (GT - LC = 0.9 dB)								
BW [MHz]	RB Size	RB Offset	Mod	Lowest	Middle	Highest	EIRP (dBm)	EIRP(W)
20	1	1	PI/2 BPSK	22.61	22.31	22.52	23.51	0.2244
20	1	104		22.23	22.34	22.31		
20	50	25		22.55	22.37	22.51		
20	1	0		22.22	21.95	22.15		
20	1	105		21.80	21.90	22.01		
20	100	0		22.11	21.95	22.08		
20	1	1	QPSK	22.53	22.24	22.45		
20	1	104		22.17	22.28	22.26		
20	50	25		22.52	22.36	22.49		
20	1	0		21.58	21.36	21.54		
20	1	105		21.20	21.35	21.42		
20	100	0		21.59	21.44	21.61		
20	1	1	16-QAM	21.70	21.51	21.64	22.60	0.1820
20	1	1	64-QAM	20.08	19.72	19.95		
20	1	1	256-QAM	17.71	17.53	17.71		
Limit	EIRP < 2W			Result			Pass	



NR n38 Maximum Average Power [dBm] (GT - LC = 2.3 dB)								
BW [MHz]	RB Size	RB Offset	Mod	Lowest	Middle	Highest	EIRP (dBm)	EIRP(W)
20	1	1	PI/2 BPSK	23.91	23.82	23.83	26.21	0.4178
20	1	49		23.88	23.78	23.76		
20	25	12		23.89	23.81	23.80		
20	1	0		23.47	23.35	23.15		
20	1	50		23.37	23.21	23.09		
20	50	0		23.48	23.32	23.11		
20	1	1	QPSK	23.83	23.75	23.59	26.21	0.4178
20	1	49		23.86	23.46	23.62		
20	25	12		23.81	23.72	23.57		
20	1	0		22.95	22.80	23.80		
20	1	50		22.83	22.53	22.61		
20	50	0		22.95	22.68	22.82		
20	1	1	16-QAM	22.95	22.76	22.82	25.25	0.3350
20	1	1	64-QAM	21.59	21.53	21.06		
20	1	1	256-QAM	19.24	19.15	19.04		
Limit	EIRP < 2W			Result			Pass	



NR n41 Maximum Average Power [dBm] (GT - LC = 0.6 dB)								
BW [MHz]	RB Size	RB Offset	Mod	Lowest	Middle	Highest	EIRP (dBm)	EIRP(W)
20	1	1	PI/2 BPSK	22.49	22.01	20.30	23.24	0.2109
20	1	49		22.64	21.89	21.66		
20	25	12		22.63	22.46	21.24		
20	1	0		22.08	21.37	20.01		
20	1	50		22.35	21.18	21.08		
20	50	0		22.36	21.47	20.02		
20	1	1	QPSK	22.59	22.14	20.26		
20	1	49		22.64	22.62	21.63		
20	25	12		22.57	22.58	21.07		
20	1	0		21.53	22.48	20.31		
20	1	50		21.93	21.89	21.64		
20	50	0		21.84	21.76	20.13		
20	1	1	16-QAM	21.53	21.05	20.01	22.13	0.1633
20	1	1	64-QAM	19.96	20.21	18.51		
20	1	1	256-QAM	17.85	18.85	16.46		
Limit	EIRP < 2W			Result			Pass	

NR n41 Maximum Average Power [dBm] (GT - LC = 0.6 dB)								
BW [MHz]	RB Size	RB Offset	Mod	Lowest	Middle	Highest	EIRP (dBm)	EIRP(W)
40	1	1	PI/2 BPSK	22.57	22.54	21.37	23.31	0.2143
40	1	104		22.66	22.56	21.56		
40	50	25		22.57	22.53	20.04		
40	1	0		22.14	22.65	21.30		
40	1	105		22.59	22.35	20.98		
40	100	0		22.46	22.45	20.55		
40	1	1	QPSK	22.63	22.57	21.35		
40	1	104		22.71	22.66	21.35		
40	50	25		22.61	22.53	20.08		
40	1	0		21.67	22.43	21.27		
40	1	105		22.19	22.03	20.05		
40	100	0		22.01	21.71	20.02		
40	1	1	16-QAM	21.63	21.56	20.52	22.23	0.1671
40	1	1	64-QAM	20.11	20.73	19.92		
40	1	1	256-QAM	18.01	19.17	17.44		
Limit	EIRP < 2W			Result			Pass	



NR n41 Maximum Average Power [dBm] (GT - LC = 0.6 dB)								
BW [MHz]	RB Size	RB Offset	Mod	Lowest	Middle	Highest	EIRP (dBm)	EIRP(W)
50	1	1	PI/2 BPSK	22.45	22.48	22.51	23.32	0.2148
50	1	131		22.72	22.62	22.12		
50	64	32		22.71	22.64	21.09		
50	1	0		22.06	22.09	22.04		
50	1	132		22.31	22.32	21.59		
50	128	0		22.35	22.36	21.18		
50	1	1	QPSK	22.49	21.51	22.46		
50	1	131		22.67	22.65	22.27		
50	64	32		22.65	22.63	21.03		
50	1	0		21.54	21.53	21.63		
50	1	132		21.82	21.84	21.22		
50	128	0		21.79	21.82	20.77		
50	1	1	16-QAM	21.56	21.53	21.55	22.16	0.1644
50	1	1	64-QAM	20.02	20.07	20.23		
50	1	1	256-QAM	17.85	18.74	18.05		
Limit	EIRP < 2W			Result			Pass	

NR n41 Maximum Average Power [dBm] (GT - LC = 0.6 dB)								
BW [MHz]	RB Size	RB Offset	Mod	Lowest	Middle	Highest	EIRP (dBm)	EIRP(W)
60	1	1	PI/2 BPSK	22.46	22.65	22.69	23.34	0.2158
60	1	160		22.64	22.52	22.73		
60	81	40		22.66	22.54	22.74		
60	1	0		21.95	22.57	22.65		
60	1	161		22.08	22.62	22.54		
60	162	0		22.17	22.67	22.64		
60	1	1	QPSK	22.45	22.72	22.55		
60	1	160		22.56	22.54	22.67		
60	81	40		22.64	22.68	22.72		
60	1	0		21.43	22.19	22.10		
60	1	161		21.58	21.68	22.21		
60	162	0		21.69	22.21	22.43		
60	1	1	16-QAM	21.45	22.16	21.83	22.76	0.1888
60	1	1	64-QAM	20.04	20.71	20.60		
60	1	1	256-QAM	17.74	18.59	18.51		
Limit	EIRP < 2W			Result			Pass	



NR n41 Maximum Average Power [dBm] (GT - LC = 0.6 dB)								
BW [MHz]	RB Size	RB Offset	Mod	Lowest	Middle	Highest	EIRP (dBm)	EIRP(W)
80	1	1	PI/2 BPSK	22.01	22.66	22.26	23.29	0.2133
80	1	215		22.33	22.19	22.62		
80	108	54		22.38	22.68	22.00		
80	1	0		21.74	22.38	21.92		
80	1	216		21.88	21.67	22.16		
80	216	0		21.87	22.39	21.76		
80	1	1	QPSK	22.03	22.69	22.30		
80	1	215		22.32	22.13	21.92		
80	108	54		22.38	22.59	22.02		
80	1	0		21.24	21.82	21.40		
80	1	216		21.42	21.16	21.48		
80	216	0		21.34	22.01	21.25		
80	1	1	16-QAM	21.13	21.79	21.47	22.39	0.1734
80	1	1	64-QAM	19.43	20.54	19.84		
80	1	1	256-QAM	17.42	18.24	17.64		
Limit	EIRP < 2W			Result			Pass	

NR n41 Maximum Average Power [dBm] (GT - LC = 0.6 dB)								
BW [MHz]	RB Size	RB Offset	Mod	Lowest	Middle	Highest	EIRP (dBm)	EIRP(W)
90	1	1	PI/2 BPSK	22.07	22.70	22.58	23.30	0.2138
90	1	243		21.80	22.12	22.43		
90	120	60		22.18	22.65	22.11		
90	1	0		21.70	22.43	22.29		
90	1	244		21.35	21.73	21.92		
90	240	0		21.70	22.42	21.84		
90	1	1	QPSK	22.08	22.49	22.65		
90	1	243		21.78	22.16	21.86		
90	120	60		22.19	22.53	22.14		
90	1	0		21.23	21.85	21.90		
90	1	244		20.88	21.34	20.75		
90	240	0		21.23	21.94	21.29		
90	1	1	16-QAM	21.04	21.82	21.80	22.42	0.1746
90	1	1	64-QAM	19.50	20.31	20.19		
90	1	1	256-QAM	17.56	18.15	18.17		
Limit	EIRP < 2W			Result			Pass	



NR n41 Maximum Average Power [dBm] (GT - LC = 0.6 dB)								
BW [MHz]	RB Size	RB Offset	Mod	Lowest	Middle	Highest	EIRP (dBm)	EIRP(W)
100	1	1	PI/2 BPSK	21.89	22.72	22.77	23.37	0.2173
100	1	271		21.48	21.96	21.84		
100	135	67		22.20	22.68	21.94		
100	1	0		21.48	22.12	22.17		
100	1	272		21.09	21.56	21.37		
100	270	0		21.69	22.14	21.84		
100	1	1	QPSK	21.92	22.53	22.75		
100	1	271		21.53	22.00	22.03		
100	135	67		22.13	22.70	21.96		
100	1	0		21.48	21.74	21.94		
100	1	272		21.18	21.05	21.47		
100	270	0		21.68	21.65	21.25		
100	1	1	16-QAM	21.00	21.44	21.85	22.45	0.1758
100	1	1	64-QAM	19.53	20.04	20.27		
100	1	1	256-QAM	17.21	18.05	18.28		
Limit	EIRP < 2W			Result			Pass	



NR n66 Maximum Average Power [dBm] (GT - LC = 3.3 dB)								
BW [MHz]	RB Size	RB Offset	Mod	Lowest	Middle	Highest	EIRP (dBm)	EIRP(W)
5	1	1	PI/2 BPSK	23.37	23.47	23.57	26.91	0.4909
5	1	23		23.33	23.61	23.41		
5	12	6		22.41	23.53	23.52		
5	1	0		22.86	23.03	22.95		
5	1	24		22.80	23.14	22.93		
5	25	0		22.91	23.03	23.00		
5	1	1	QPSK	23.35	23.43	23.56		
5	1	23		23.31	23.56	23.38		
5	12	6		22.36	23.46	23.48		
5	1	0		22.40	22.45	22.53		
5	1	24		22.27	22.57	22.34		
5	25	0		22.37	22.49	22.43		
5	1	1	16-QAM	22.42	22.77	22.53	26.07	0.4046
5	1	1	64-QAM	21.07	21.12	21.23		
5	1	1	256-QAM	18.27	18.52	18.35		
Limit	EIRP < 1W			Result			Pass	

NR n66 Maximum Average Power [dBm] (GT - LC = 3.3 dB)								
BW [MHz]	RB Size	RB Offset	Mod	Lowest	Middle	Highest	EIRP (dBm)	EIRP(W)
10	1	1	PI/2 BPSK	23.60	23.60	23.59	26.95	0.4955
10	1	50		23.51	23.65	23.46		
10	25	12		23.56	23.64	23.57		
10	1	0		23.03	23.05	23.05		
10	1	51		22.87	23.19	22.91		
10	50	0		23.08	23.15	23.08		
10	1	1	QPSK	23.56	23.57	23.58		
10	1	50		23.50	23.62	23.43		
10	25	12		23.52	23.63	23.58		
10	1	0		22.45	22.47	22.58		
10	1	51		22.29	22.58	22.31		
10	50	0		22.49	22.59	22.51		
10	1	1	16-QAM	22.51	22.59	22.56	25.89	0.3882
10	1	1	64-QAM	21.27	21.29	21.21		
10	1	1	256-QAM	18.50	18.54	18.48		
Limit	EIRP < 1W			Result			Pass	



NR n66 Maximum Average Power [dBm] (GT - LC = 3.3 dB)								
BW [MHz]	RB Size	RB Offset	Mod	Lowest	Middle	Highest	EIRP (dBm)	EIRP(W)
15	1	1	PI/2 BPSK	23.67	23.62	23.58	26.97	0.4977
15	1	77		23.56	23.59	23.44		
15	36	18		23.51	23.65	23.46		
15	1	0		23.15	23.06	23.06		
15	1	78		22.95	23.22	22.91		
15	75	0		23.04	23.24	23.02		
15	1	1	QPSK	23.64	23.61	23.56		
15	1	77		23.53	23.56	23.43		
15	36	18		23.50	23.66	23.48		
15	1	0		22.61	22.55	23.58		
15	1	78		22.37	22.67	22.34		
15	75	0		22.58	22.70	22.49		
15	1	1	16-QAM	22.47	22.59	22.58	25.89	0.3882
15	1	1	64-QAM	21.26	21.29	21.25		
15	1	1	256-QAM	18.60	18.54	18.43		
Limit	EIRP < 1W			Result			Pass	

NR n66 Maximum Average Power [dBm] (GT - LC = 3.3 dB)								
BW [MHz]	RB Size	RB Offset	Mod	Lowest	Middle	Highest	EIRP (dBm)	EIRP(W)
20	1	1	PI/2 BPSK	23.69	23.62	23.64	26.99	0.5000
20	1	104		23.51	23.68	23.51		
20	50	25		23.51	23.66	23.61		
20	1	0		23.13	23.19	23.15		
20	1	105		22.98	23.25	22.91		
20	100	0		23.06	23.23	23.08		
20	1	1	QPSK	23.61	23.57	23.63		
20	1	104		23.50	23.66	23.50		
20	50	25		23.50	23.64	23.57		
20	1	0		22.56	22.63	22.65		
20	1	105		22.50	22.85	22.45		
20	100	0		22.51	22.72	22.59		
20	1	1	16-QAM	22.60	22.66	22.65	25.96	0.3945
20	1	1	64-QAM	21.31	21.39	21.38		
20	1	1	256-QAM	18.57	18.53	18.52		
Limit	EIRP < 1W			Result			Pass	



NR n71 Maximum Average Power [dBm] (GT - LC = 0 dB)								
BW [MHz]	RB Size	RB Offset	Mod	Lowest	Middle	Highest	ERP (dBm)	ERP(W)
5	1	1	PI/2 BPSK	23.07	22.52	22.79	20.92	0.1236
5	1	23		22.88	22.44	22.65		
5	12	6		23.06	22.61	22.76		
5	1	0		22.67	22.04	22.38		
5	1	24		22.42	22.00	22.22		
5	25	0		22.67	22.19	22.31		
5	1	1	QPSK	23.03	22.46	22.72		
5	1	23		22.81	22.37	22.55		
5	12	6		23.02	22.57	22.70		
5	1	0		22.11	21.54	21.76		
5	1	24		21.87	21.50	21.67		
5	25	0		22.12	21.65	21.78		
5	1	1	16-QAM	22.34	21.68	21.85	20.19	0.1045
5	1	1	64-QAM	20.59	20.00	20.20		
5	1	1	256-QAM	18.45	17.77	17.98		
Limit	ERP < 3W			Result			Pass	

NR n71 Maximum Average Power [dBm] (GT - LC = 0 dB)								
BW [MHz]	RB Size	RB Offset	Mod	Lowest	Middle	Highest	ERP (dBm)	ERP(W)
10	1	1	PI/2 BPSK	23.08	22.52	22.63	20.93	0.1239
10	1	50		22.65	22.51	22.70		
10	25	12		23.02	22.67	22.78		
10	1	0		22.78	22.15	22.61		
10	1	51		22.31	22.14	22.25		
10	50	0		22.62	22.13	22.31		
10	1	1	QPSK	23.04	22.50	22.62		
10	1	50		22.51	22.46	22.62		
10	25	12		23.01	22.65	22.72		
10	1	0		22.09	21.52	21.66		
10	1	51		21.61	21.58	21.66		
10	50	0		22.04	21.60	21.77		
10	1	1	16-QAM	22.28	21.62	21.72	20.13	0.1030
10	1	1	64-QAM	20.53	19.89	20.03		
10	1	1	256-QAM	18.29	17.64	17.81		
Limit	ERP < 3W			Result			Pass	



NR n71 Maximum Average Power [dBm] (GT - LC = 0 dB)										
BW [MHz]	RB Size	RB Offset	Mod	Lowest	Middle	Highest	ERP (dBm)	ERP(W)		
15	1	1	PI/2 BPSK	23.16	22.70	22.62	21.01	0.1262		
15	1	77		22.61	22.72	22.72				
15	36	18		22.85	22.68	22.68				
15	1	0		22.76	22.25	22.18				
15	1	78		22.18	22.16	22.26				
15	75	0		22.45	22.35	22.25				
15	1	1	QPSK	23.11	22.58	22.56			21.01	0.1262
15	1	77		22.54	22.54	22.71				
15	36	18		22.89	22.67	22.64				
15	1	0		22.11	21.67	21.60				
15	1	78		21.53	21.56	21.66				
15	75	0		21.92	21.78	21.73				
15	1	1	16-QAM	22.38	21.86	21.74	20.23	0.1054		
15	1	1	64-QAM	20.67	20.19	20.05				
15	1	1	256-QAM	18.41	17.86	17.79				
Limit	ERP < 3W			Result			Pass			

NR n71 Maximum Average Power [dBm] (GT - LC = 0 dB)										
BW [MHz]	RB Size	RB Offset	Mod	Lowest	Middle	Highest	ERP (dBm)	ERP(W)		
20	1	1	PI/2 BPSK	23.18	22.82	22.70	21.03	0.1268		
20	1	104		22.57	22.75	22.71				
20	50	25		22.85	22.63	22.67				
20	1	0		22.75	22.44	22.33				
20	1	105		22.16	22.31	22.32				
20	100	0		22.43	22.35	22.25				
20	1	1	QPSK	23.12	22.73	22.64			21.03	0.1268
20	1	104		22.50	22.65	22.64				
20	50	25		22.83	22.72	22.63				
20	1	0		22.16	21.80	21.71				
20	1	105		21.59	21.72	21.73				
20	100	0		21.97	21.84	21.77				
20	1	1	16-QAM	22.32	21.93	21.87	20.17	0.1040		
20	1	1	64-QAM	20.55	20.19	20.14				
20	1	1	256-QAM	18.35	17.96	17.83				
Limit	ERP < 3W			Result			Pass			



FR1 n2

Peak-to-Average Ratio

Mode	FR1 n2 / 20MHz / DFT-S OFDM				
Mod.	PI/2 BPSK	QPSK	16QAM	64QAM	Limit: 13dB
RB Size	Full RB	Full RB	Full RB	Full RB	Result
Middle CH	3.62	4.29	5.48	5.88	PASS
Mode	FR1 n2 / 20MHz / DFT-S OFDM				
Mod.	256QAM				Limit: 13dB
RB Size	Full RB				Result
Middle CH	6.55				PASS



FR1 n2 / 20MHz / DFT-S OFDM / Middle Channel / Full RB

PI/2 BPSK

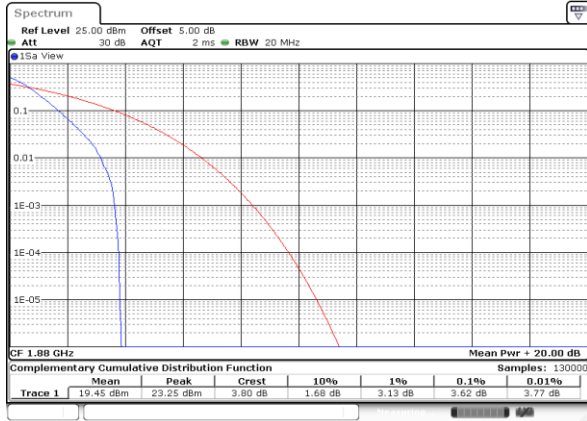

QPSK

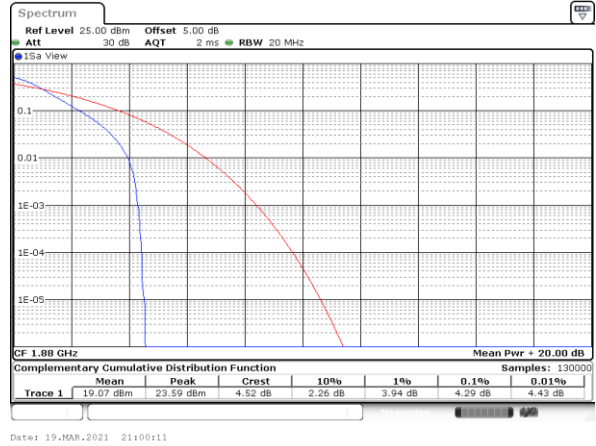

16QAM

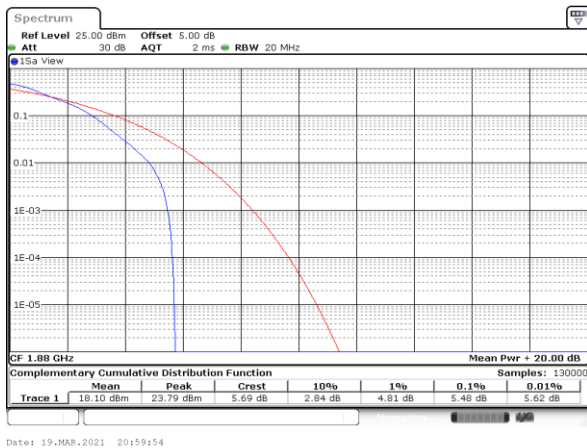

64QAM

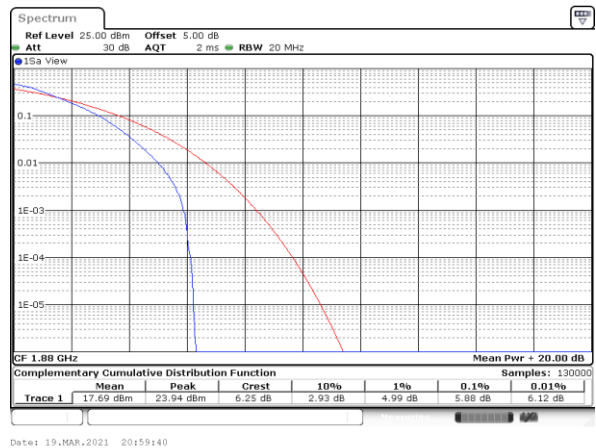

256QAM

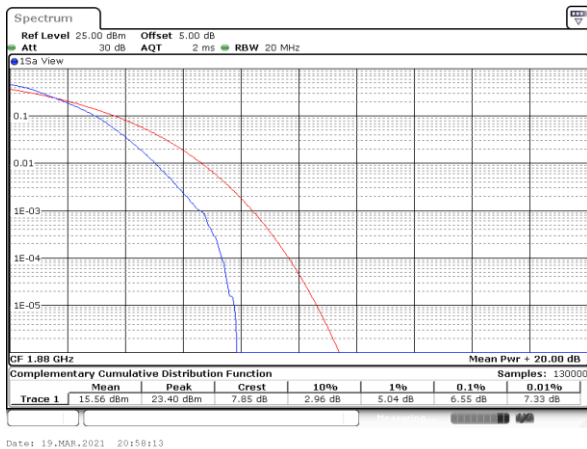



26dB Bandwidth

Mode	FR1 n2 : 26dB BW(MHz) / DFT-S OFDM							
BW	5MHz		10MHz		15MHz		20MHz	
Mod.	PI/2 BPSK		PI/2 BPSK		PI/2 BPSK		PI/2 BPSK	
Middle CH	4.83		9.45		14.30		18.90	

Mode	FR1 n2 : 26dB BW(MHz) / CP OFDM							
BW	5MHz		10MHz		15MHz		20MHz	
Mod.	QPSK	16QAM	QPSK	16QAM	QPSK	16QAM	QPSK	16QAM
Middle CH	4.93	4.97	9.75	9.75	14.93	14.93	19.86	20.02
Mod.	64QAM	256QAM	64QAM	256QAM	64QAM	256QAM	64QAM	256QAM
Middle CH	4.95	4.93	9.75	9.85	14.90	15.11	19.78	19.94



FR1 n2 / 5MHz / DFT-S OFDM / Middle Channel / Full RB

PI/2 BPSK

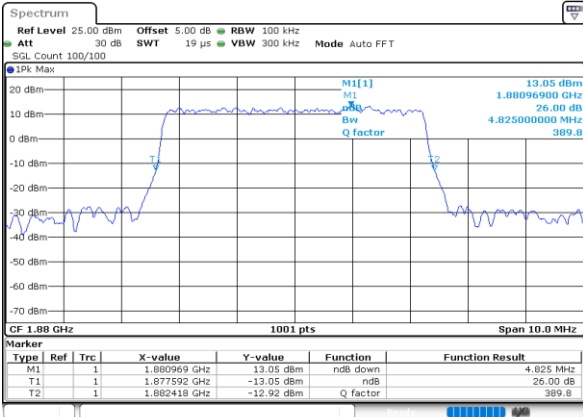

Date: 19_MAR.2021 21:23:28

FR1 n2 / 5MHz / CP OFDM / Middle Channel / Full RB

QPSK

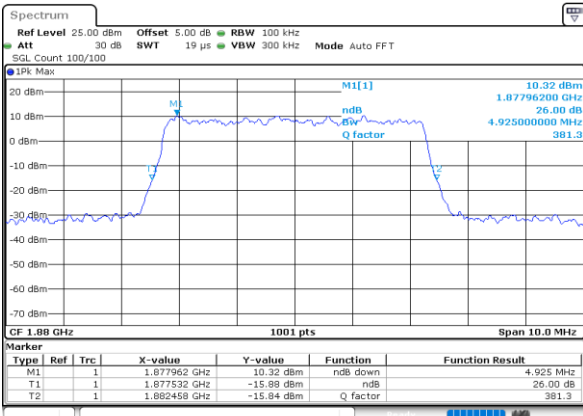

Date: 19_MAR.2021 21:24:38

16QAM

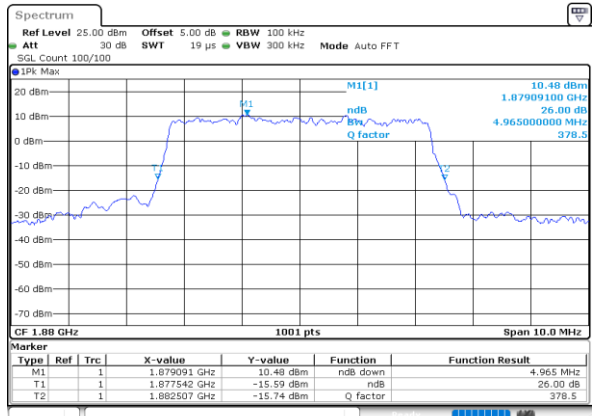

Date: 19_MAR.2021 21:24:58

64QAM

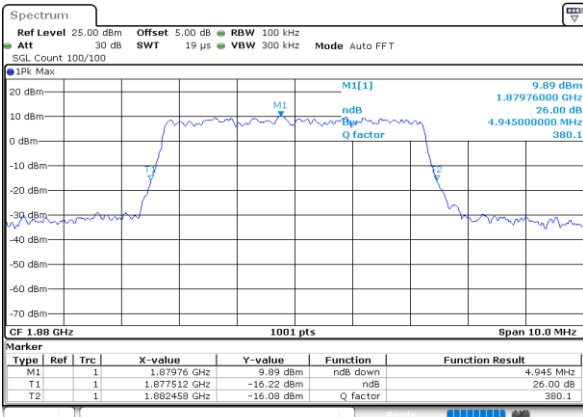

Date: 19_MAR.2021 21:25:56

256QAM

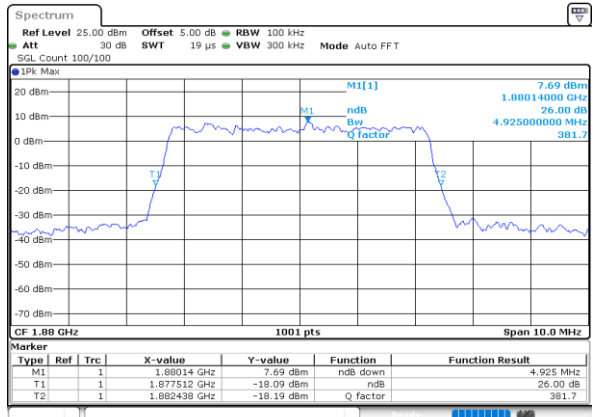

Date: 19_MAR.2021 21:26:14



FR1 n2 / 10MHz / DFT-S OFDM / Middle Channel / Full RB

PI/2 BPSK

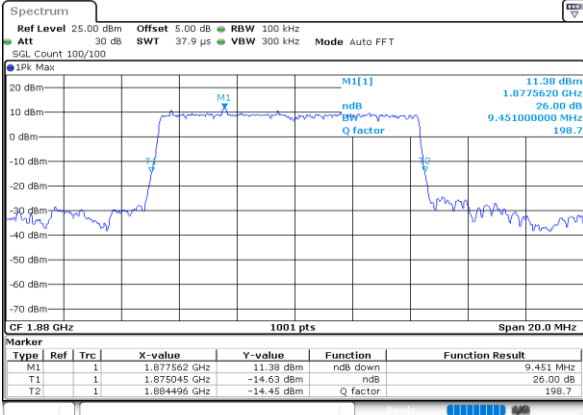

Date: 19.MAR.2021 21:21:55

FR1 n2 / 10MHz / CP OFDM / Middle Channel / Full RB

QPSK

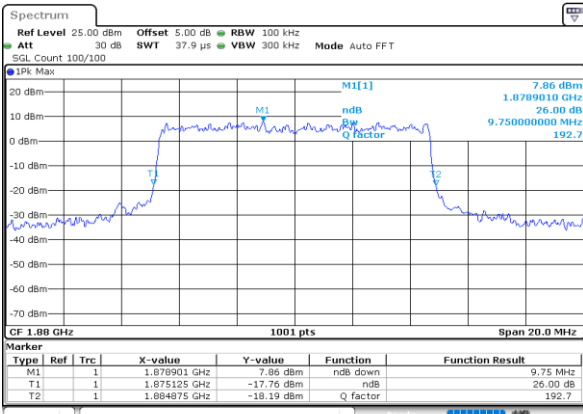

Date: 19.MAR.2021 21:21:28

16QAM

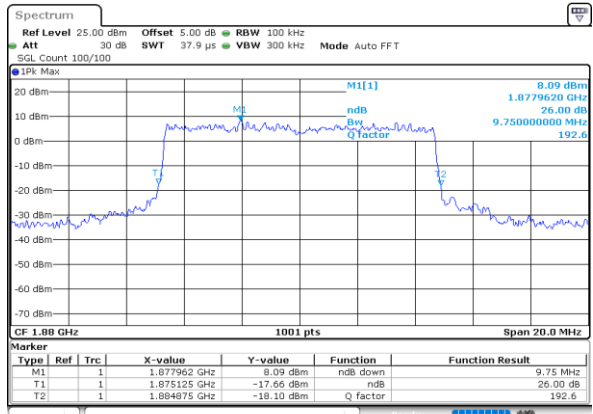

Date: 19.MAR.2021 21:21:07

64QAM

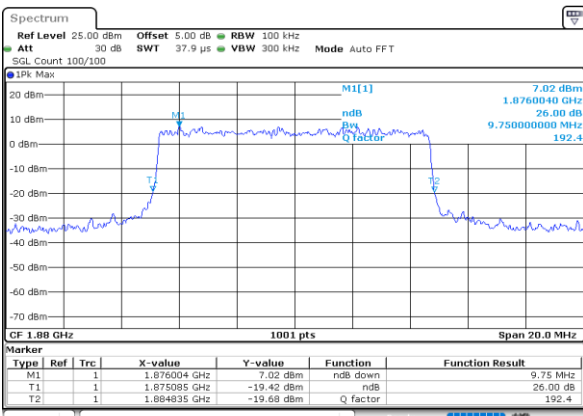

Date: 19.MAR.2021 21:20:47

256QAM

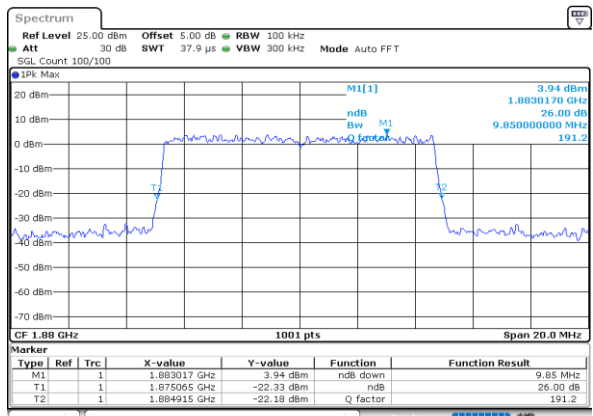

Date: 19.MAR.2021 21:13:36



FR1 n2 / 15MHz / DFT-S OFDM / Middle Channel / Full RB

PI/2 BPSK

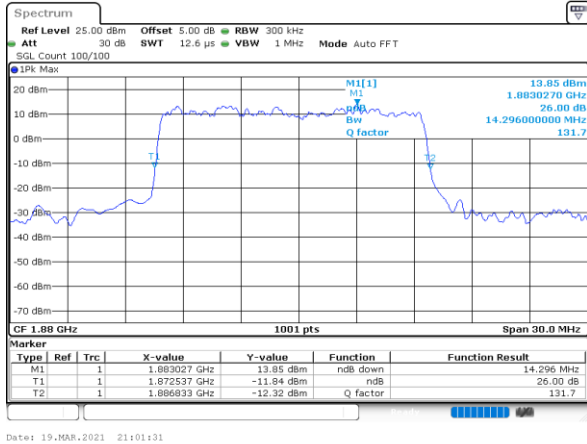

Date: 19_MAR.2021 21:01:01

FR1 n2 / 15MHz / CP OFDM / Middle Channel / Full RB

QPSK

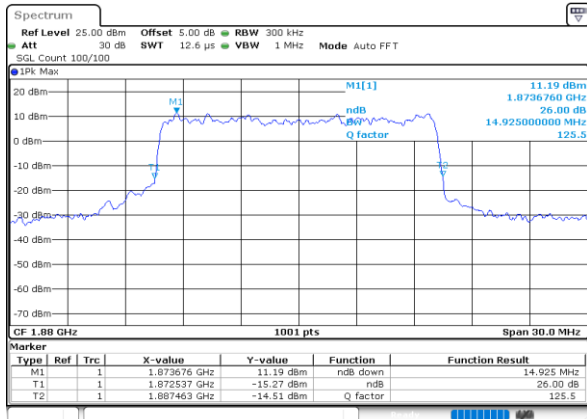

Date: 19_MAR.2021 21:02:17

16QAM

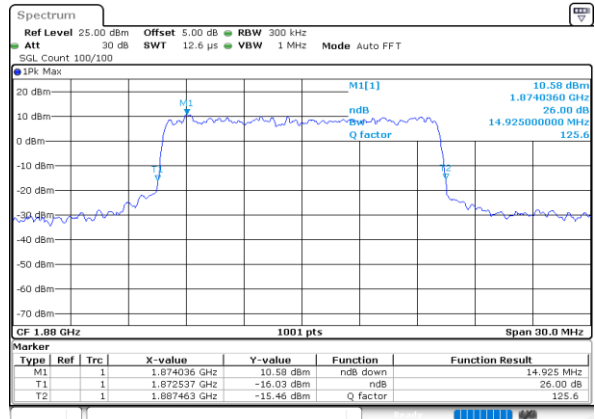

Date: 19_MAR.2021 21:11:01

64QAM

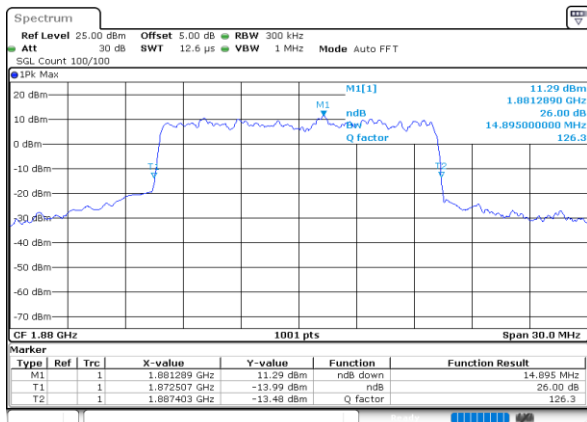

Date: 19_MAR.2021 21:12:01

256QAM

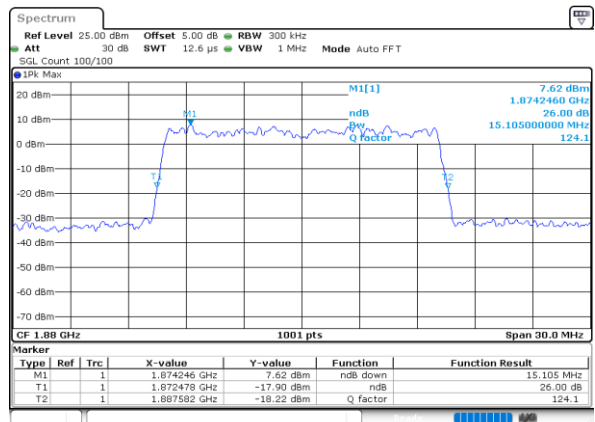

Date: 19_MAR.2021 21:12:55



FR1 n2 / 20MHz / DFT-S OFDM / Middle Channel / Full RB

PI/2 BPSK

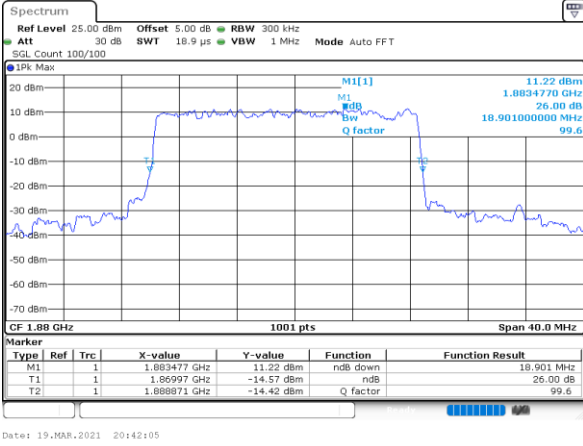

Date: 19_MAR_2021 20:42:05

FR1 n2 / 20MHz / CP OFDM / Middle Channel / Full RB

QPSK

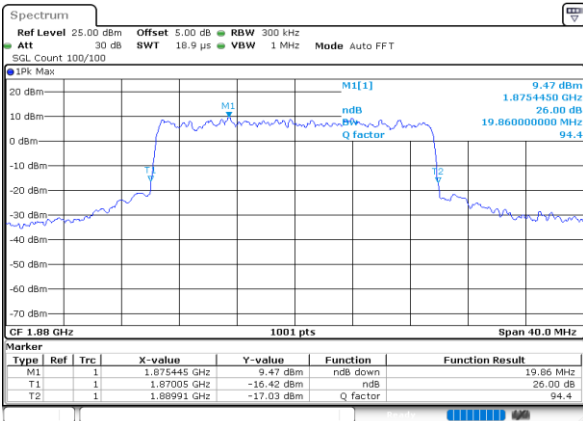

Date: 19_MAR_2021 20:48:20

16QAM

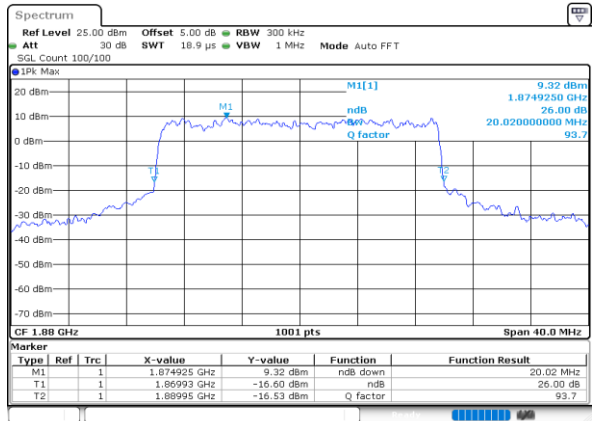

Date: 19_MAR_2021 20:50:12

64QAM

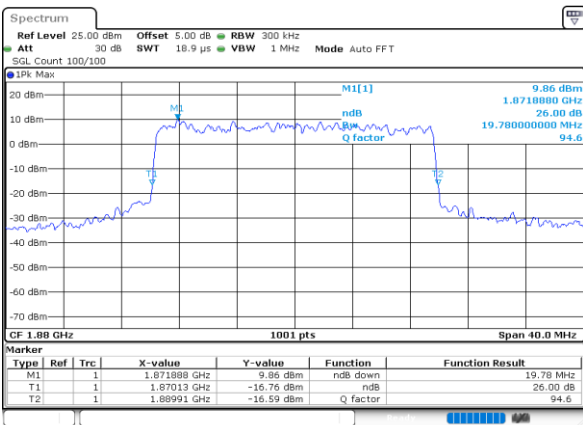

Date: 19_MAR_2021 20:56:18

256QAM

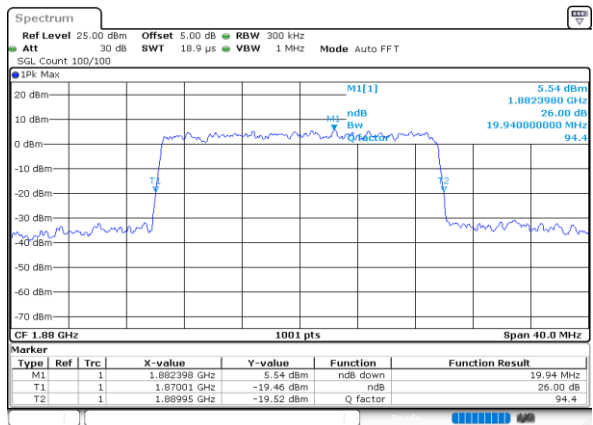

Date: 19_MAR_2021 20:57:10



Occupied Bandwidth

Mode	FR1 n2 : 99%OBW(MHz) / DFT-S OFDM							
BW	5MHz		10MHz		15MHz		20MHz	
Mod.	PI/2 BPSK		PI/2 BPSK		PI/2 BPSK		PI/2 BPSK	
Middle CH	4.47		8.89		13.49		17.98	

Mode	FR1 n2 : 99%OBW (MHz) / CP OFDM							
BW	5MHz		10MHz		15MHz		20MHz	
Mod.	QPSK	16QAM	QPSK	16QAM	QPSK	16QAM	QPSK	16QAM
Middle CH	4.49	4.49	9.27	9.25	14.12	14.12	18.90	18.94
Mod.	64QAM	256QAM	64QAM	256QAM	64QAM	256QAM	64QAM	256QAM
Middle CH	4.49	4.49	9.29	9.25	14.21	14.15	18.94	18.94



FR1 n2 / 5MHz / DFT-S OFDM / Middle Channel / Full RB

PI/2 BPSK

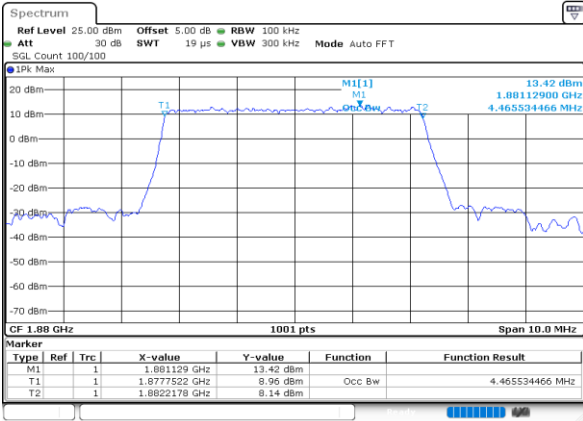

FR1 n2 / 5MHz / CP OFDM / Middle Channel / Full RB

QPSK

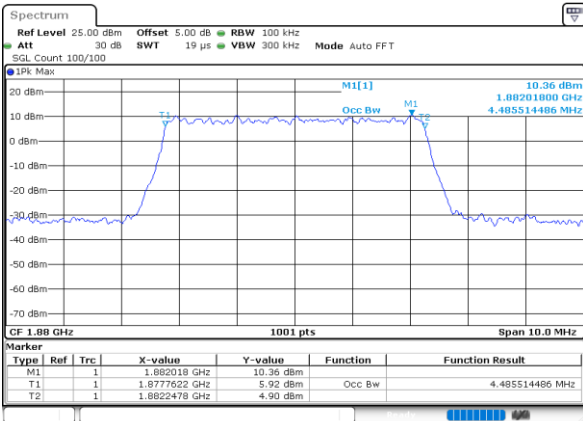

16QAM

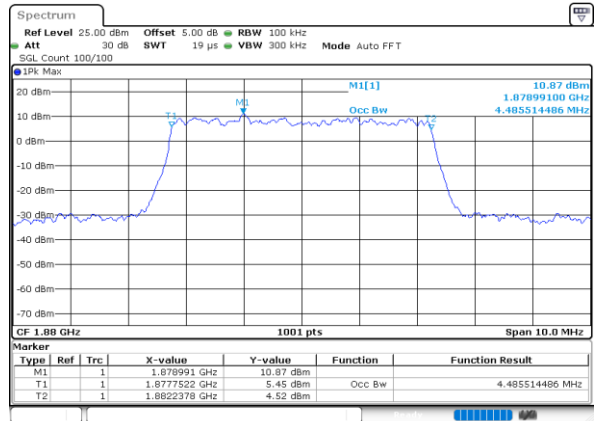

64QAM

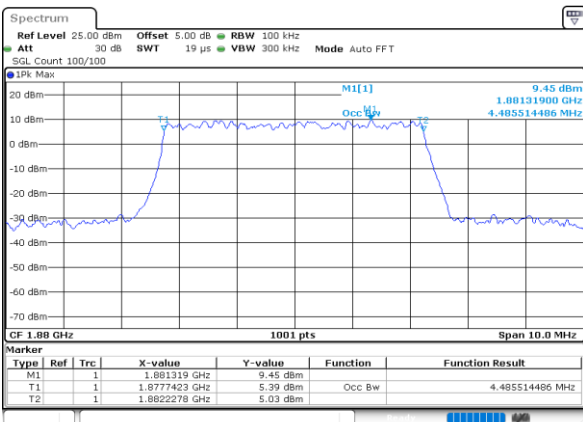

256QAM

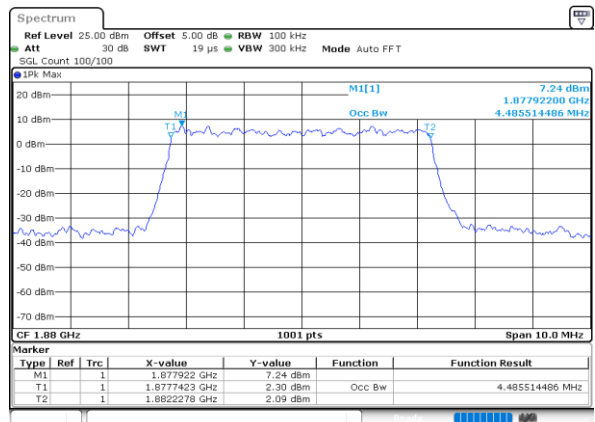



FR1 n2 / 10MHz / DFT-S OFDM / Middle Channel / Full RB

PI/2 BPSK

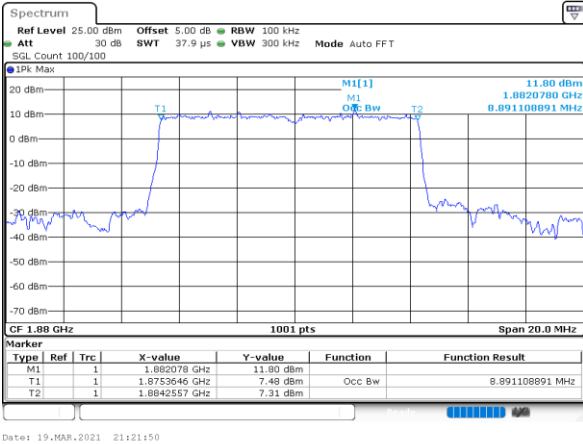

Date: 19.MAR.2021 21:21:50

FR1 n2 / 10MHz / CP OFDM / Middle Channel / Full RB

QPSK

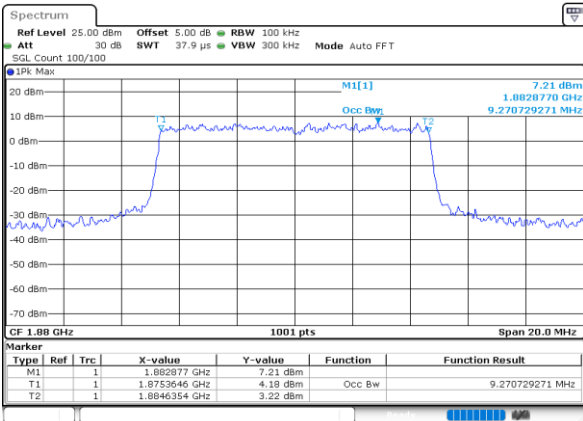

Date: 19.MAR.2021 21:21:21

16QAM

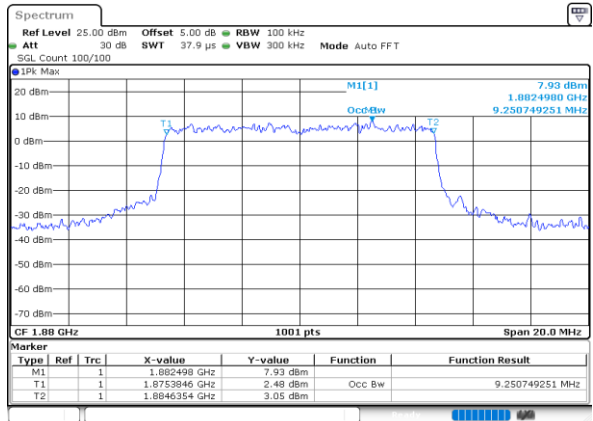

Date: 19.MAR.2021 21:21:00

64QAM

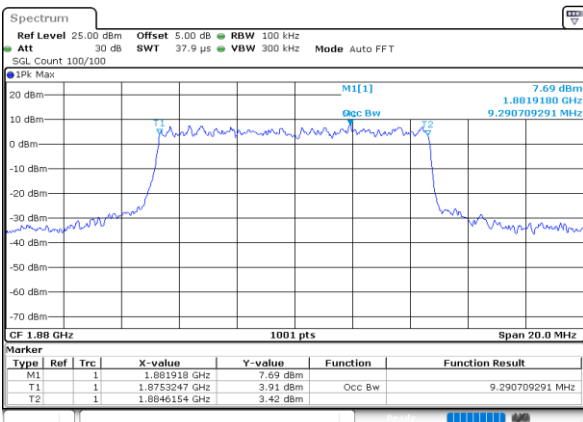

Date: 19.MAR.2021 21:20:40

256QAM

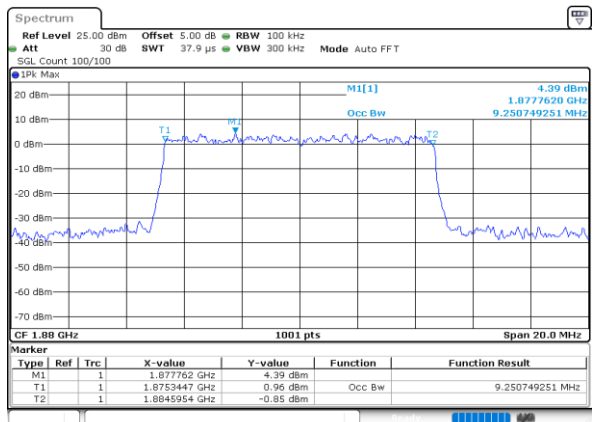

Date: 19.MAR.2021 21:13:30



FR1 n2 / 15MHz / DFT-S OFDM / Middle Channel / Full RB

PI/2 BPSK

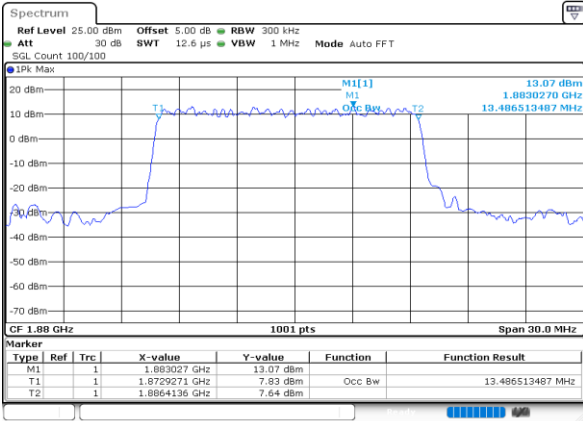

FR1 n2 / 15MHz / CP OFDM / Middle Channel / Full RB

QPSK

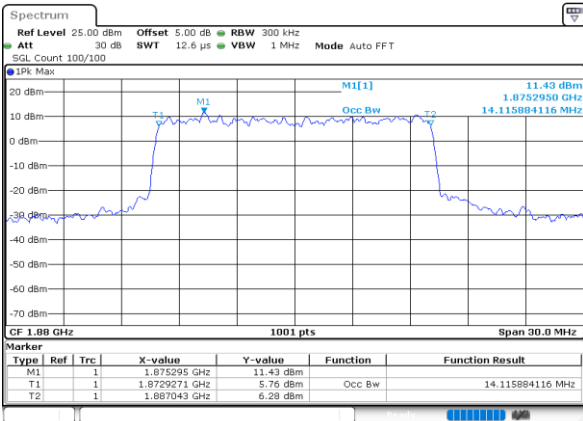

16QAM

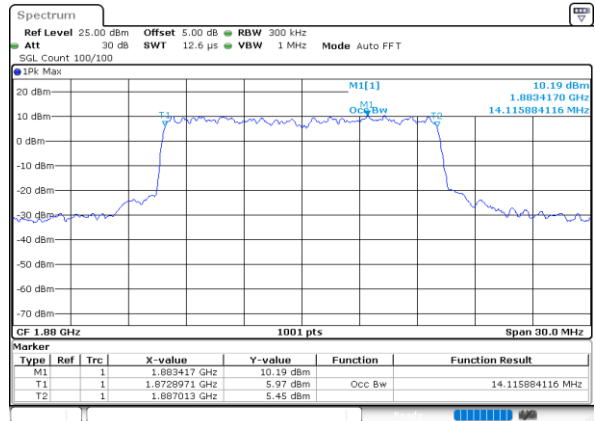

64QAM

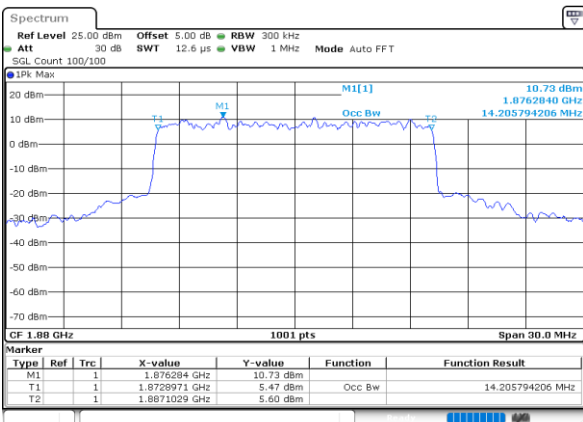

256QAM

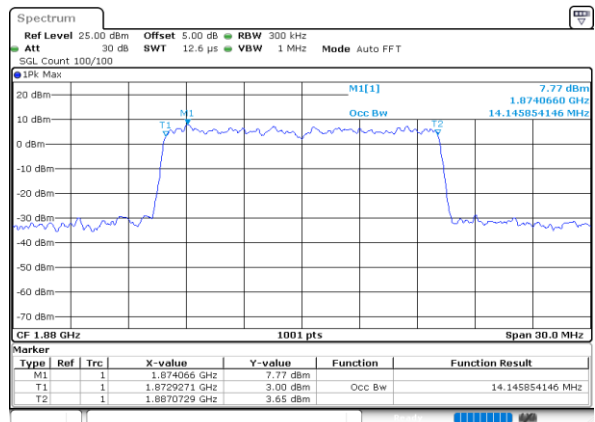



FR1 n2 / 20MHz / DFT-S OFDM / Middle Channel / Full RB

PI/2 BPSK

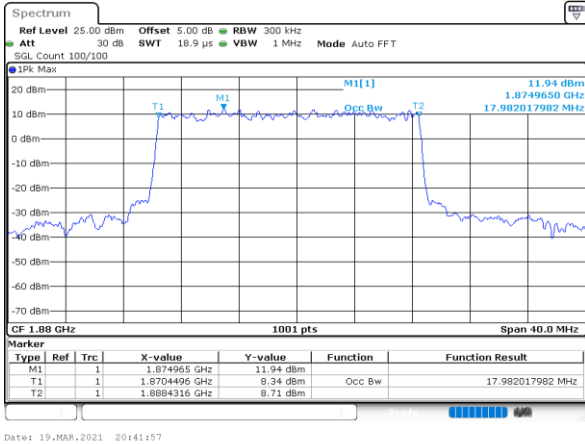

Date: 19.MAR.2021 20:41:57

FR1 n2 / 20MHz / CP OFDM / Middle Channel / Full RB

QPSK

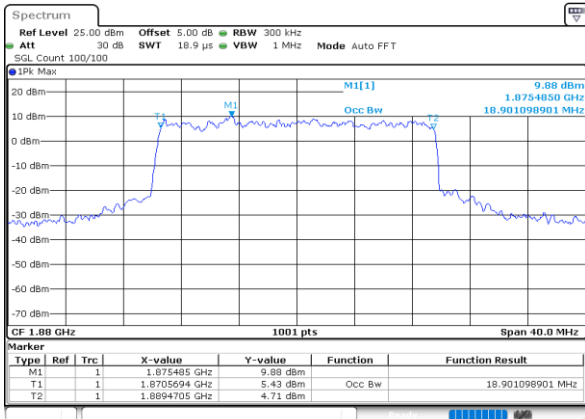

Date: 19.MAR.2021 20:48:01

16QAM

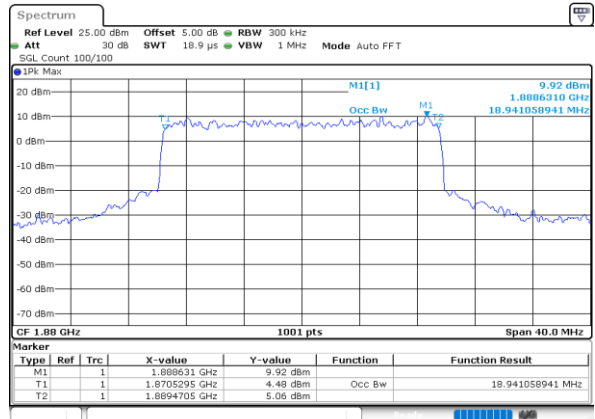

Date: 19.MAR.2021 20:50:06

64QAM

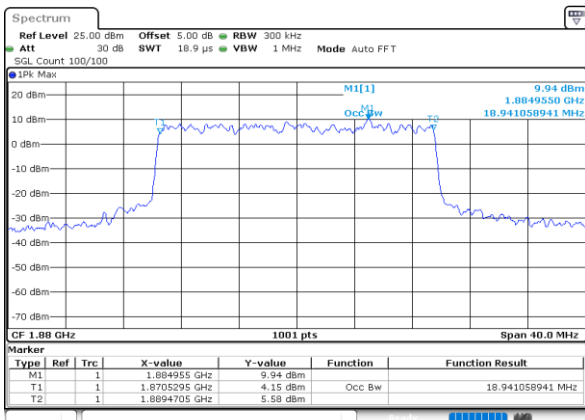

Date: 19.MAR.2021 20:56:10

256QAM

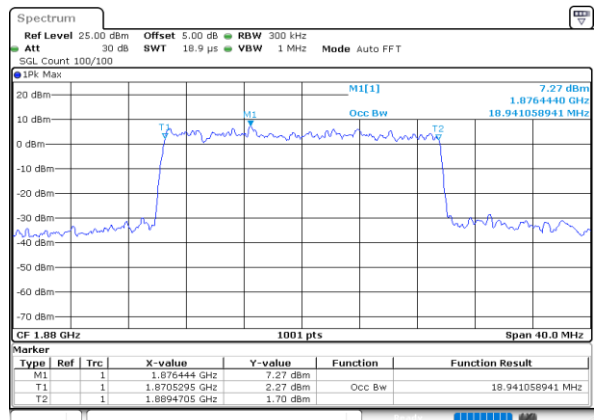

Date: 19.MAR.2021 20:57:00



Conducted Band Edge

FR1 n2 / 5MHz / DFT-S OFDM / PI/2 BPSK

Lowest Band Edge / 1RB0

Highest Band Edge / 1RBmax

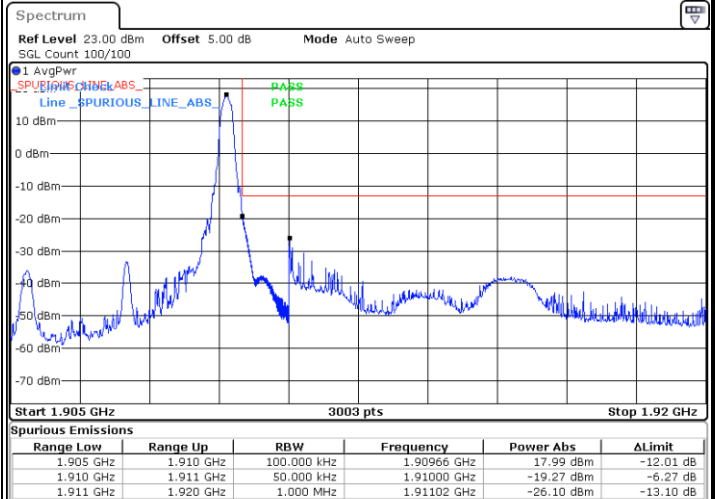
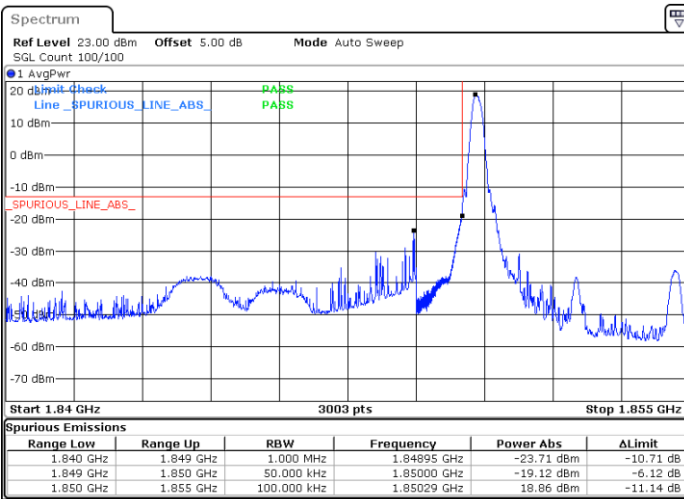

Date: 19.MAR.2021 21:54:11

Date: 19.MAR.2021 21:32:20

Lowest Band Edge / Full RB

Highest Band Edge / Full RB

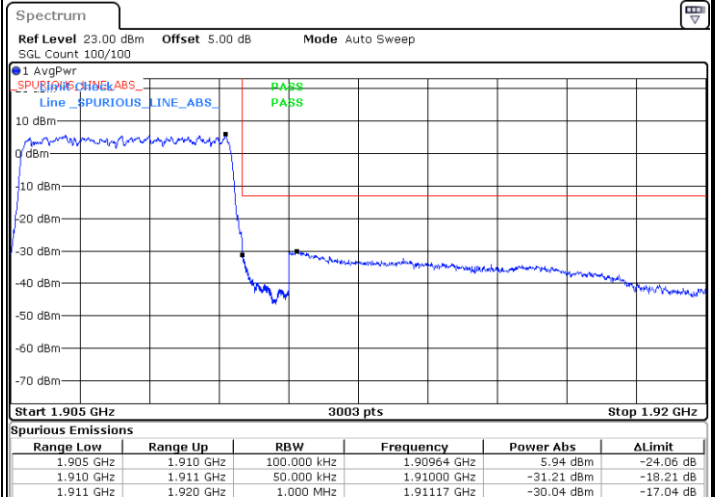
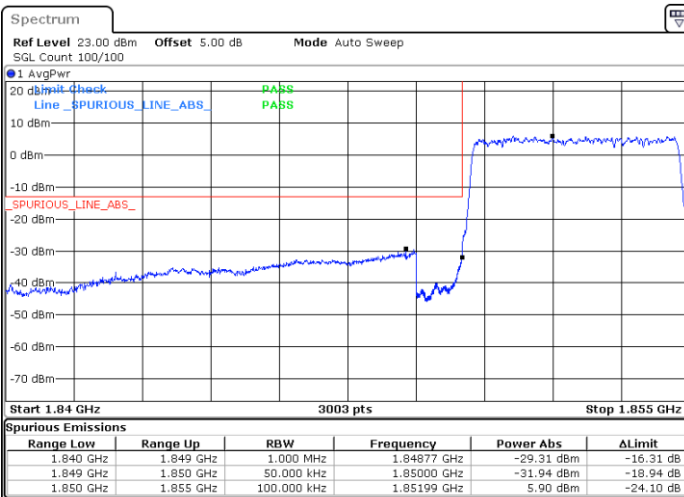

Date: 19.MAR.2021 21:48:26

Date: 19.MAR.2021 21:37:49



FR1 n2 / 5MHz / DFT-S OFDM / QPSK

Lowest Band Edge / 1RB0

Highest Band Edge / 1RBmax

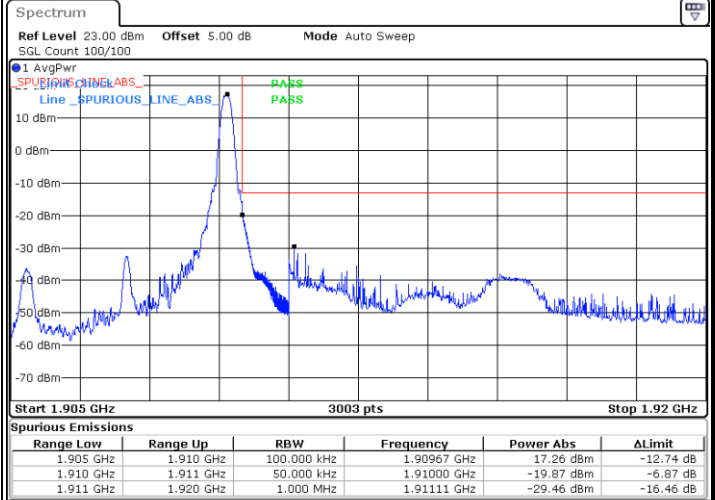
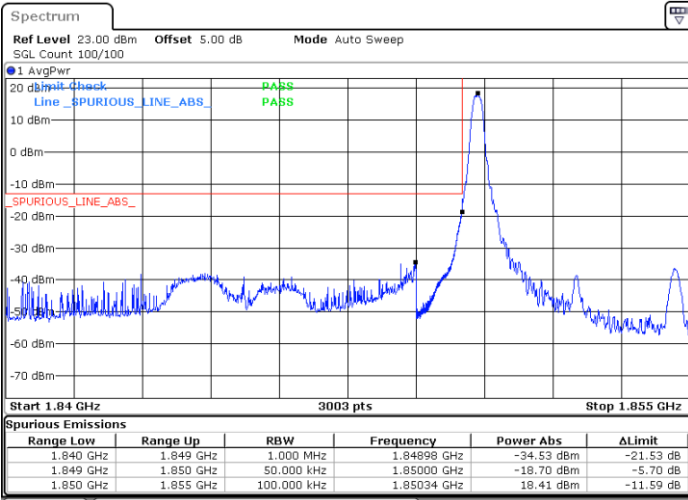

Date: 19.MAR.2021 21:53:37

Date: 19.MAR.2021 21:52:52

Lowest Band Edge / Full RB

Highest Band Edge / Full RB

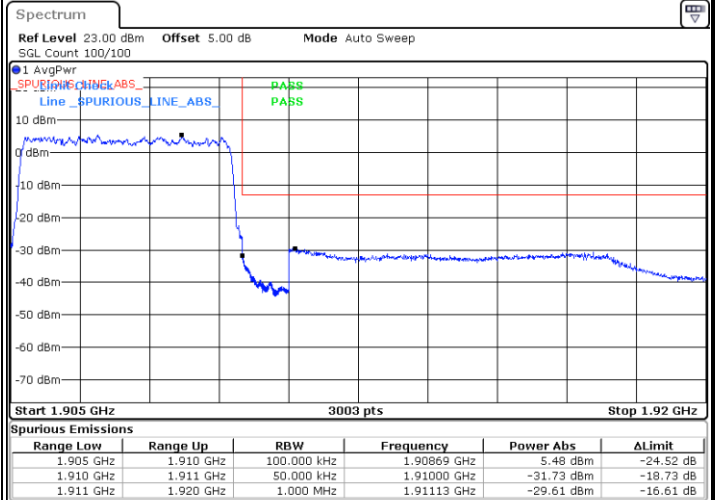
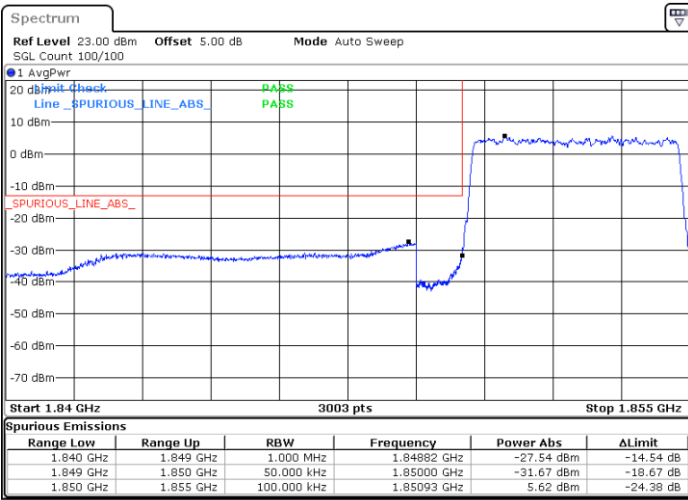

Date: 19.MAR.2021 21:49:28

Date: 19.MAR.2021 21:37:22



FR1 n2 / 5MHz / DFT-S OFDM / 16QAM

Lowest Band Edge / 1RB0

Highest Band Edge / 1RBmax

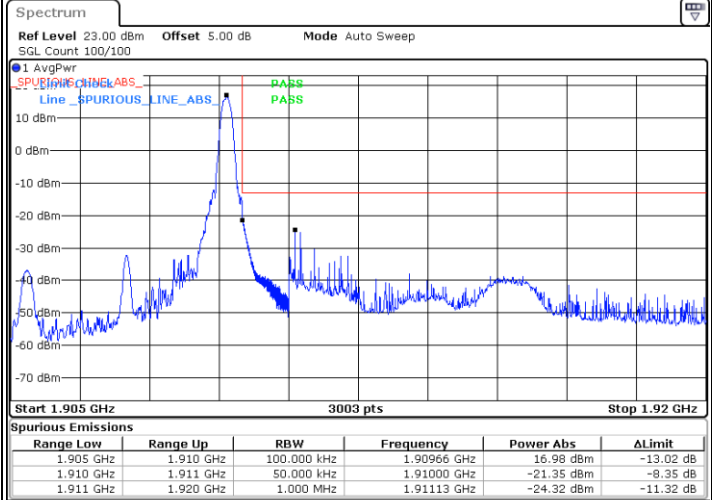
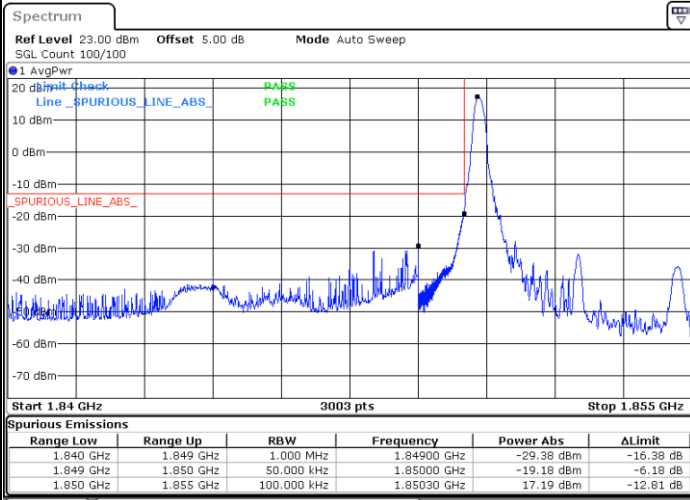

Date: 19.MAR.2021 21:53:05

Date: 19.MAR.2021 21:33:12

Lowest Band Edge / Full RB

Highest Band Edge / Full RB

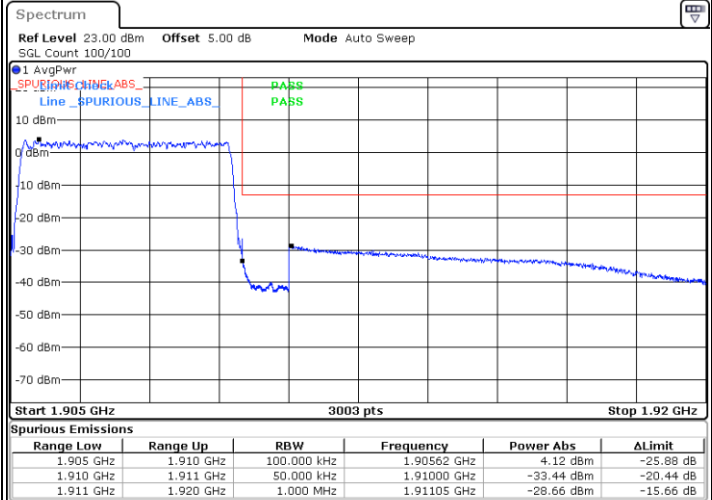
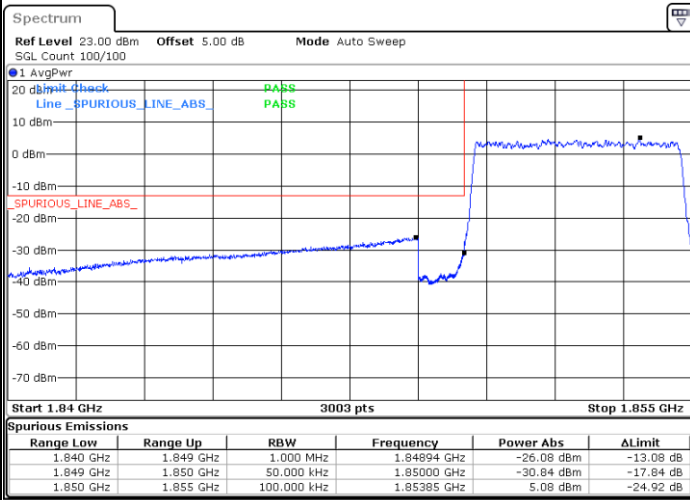

Date: 19.MAR.2021 21:50:08

Date: 19.MAR.2021 21:36:34



FR1 n2 / 5MHz / DFT-S OFDM / 64QAM

Lowest Band Edge / 1RB0

Highest Band Edge / 1RBmax

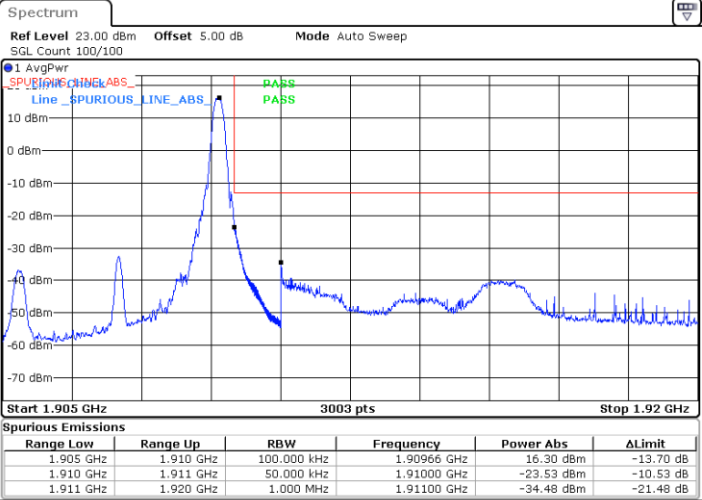
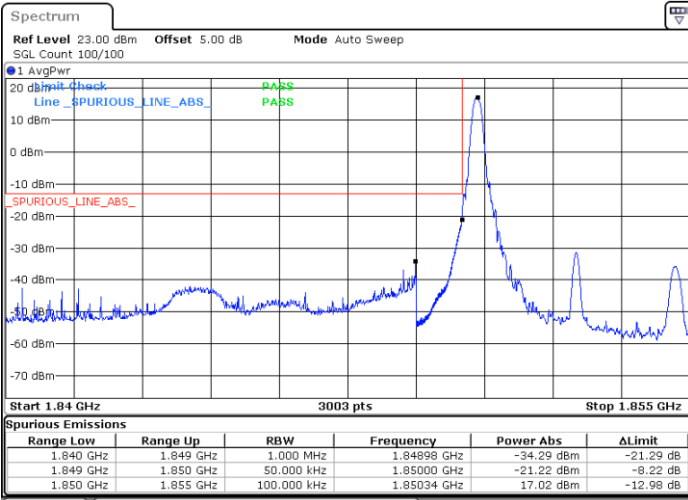

Date: 19.MAR.2021 21:52:30

Date: 19.MAR.2021 21:33:47

Lowest Band Edge / Full RB

Highest Band Edge / Full RB

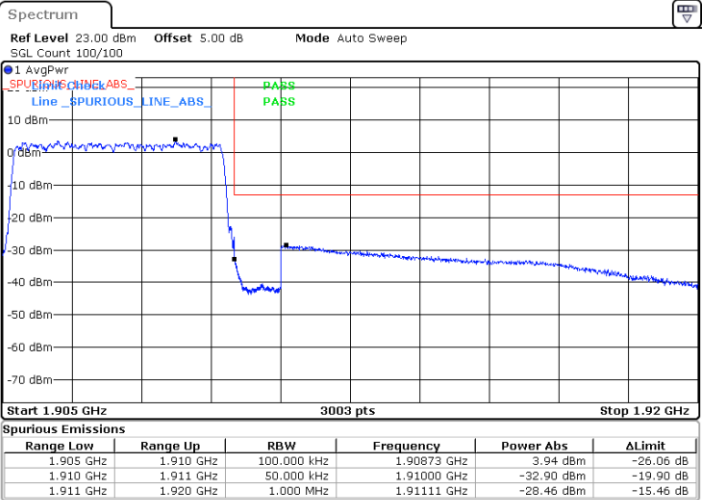
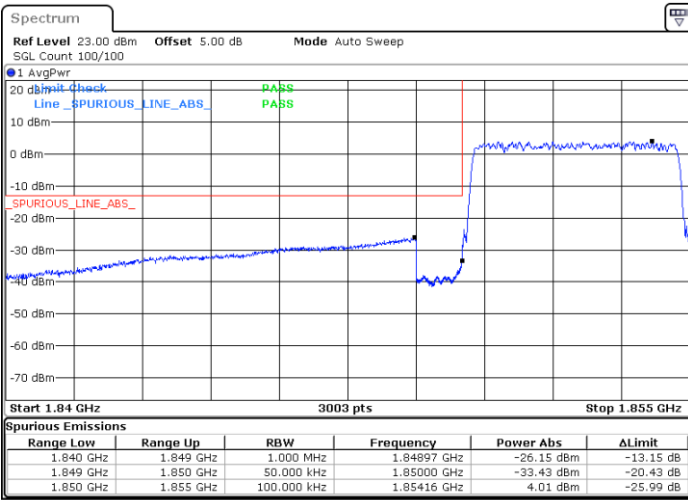

Date: 19.MAR.2021 21:50:43

Date: 19.MAR.2021 21:36:07



FR1 n2 / 5MHz / DFT-S OFDM / 256QAM

Lowest Band Edge / 1RB0

Highest Band Edge / 1RBmax

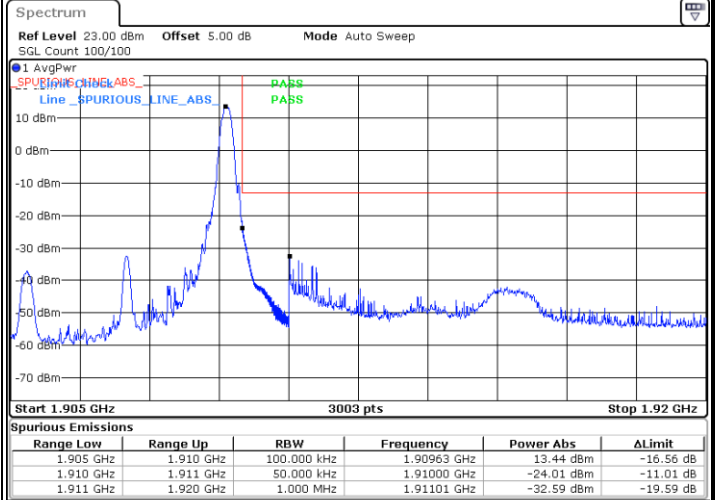
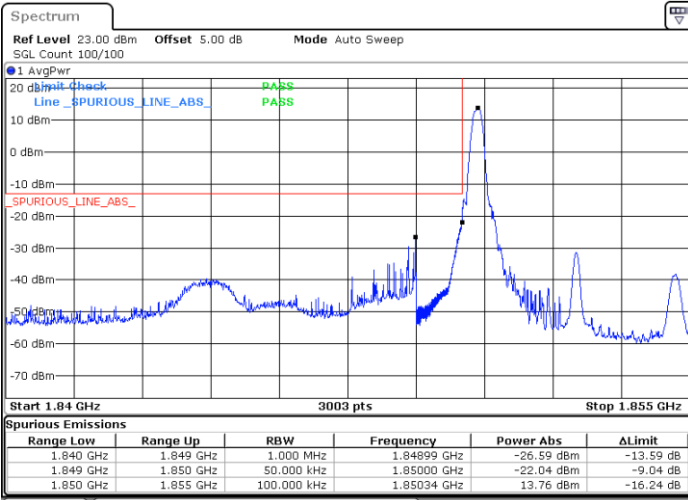

Date: 19.MAR.2021 21:51:50

Date: 19.MAR.2021 21:34:38

Lowest Band Edge / Full RB

Highest Band Edge / Full RB

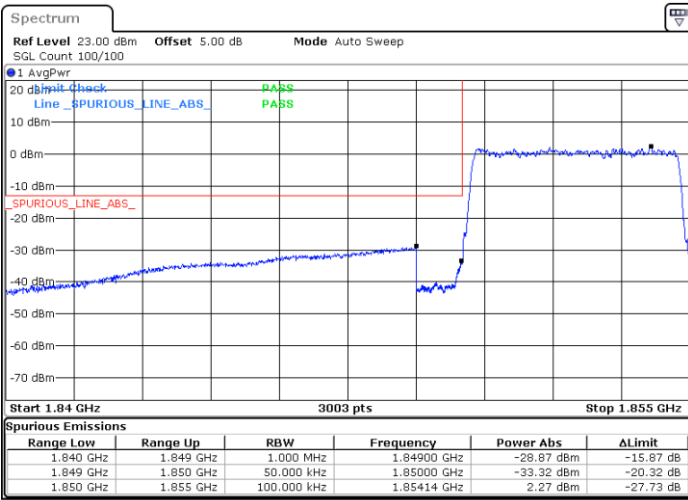

Date: 19.MAR.2021 21:51:18

Date: 19.MAR.2021 21:35:15

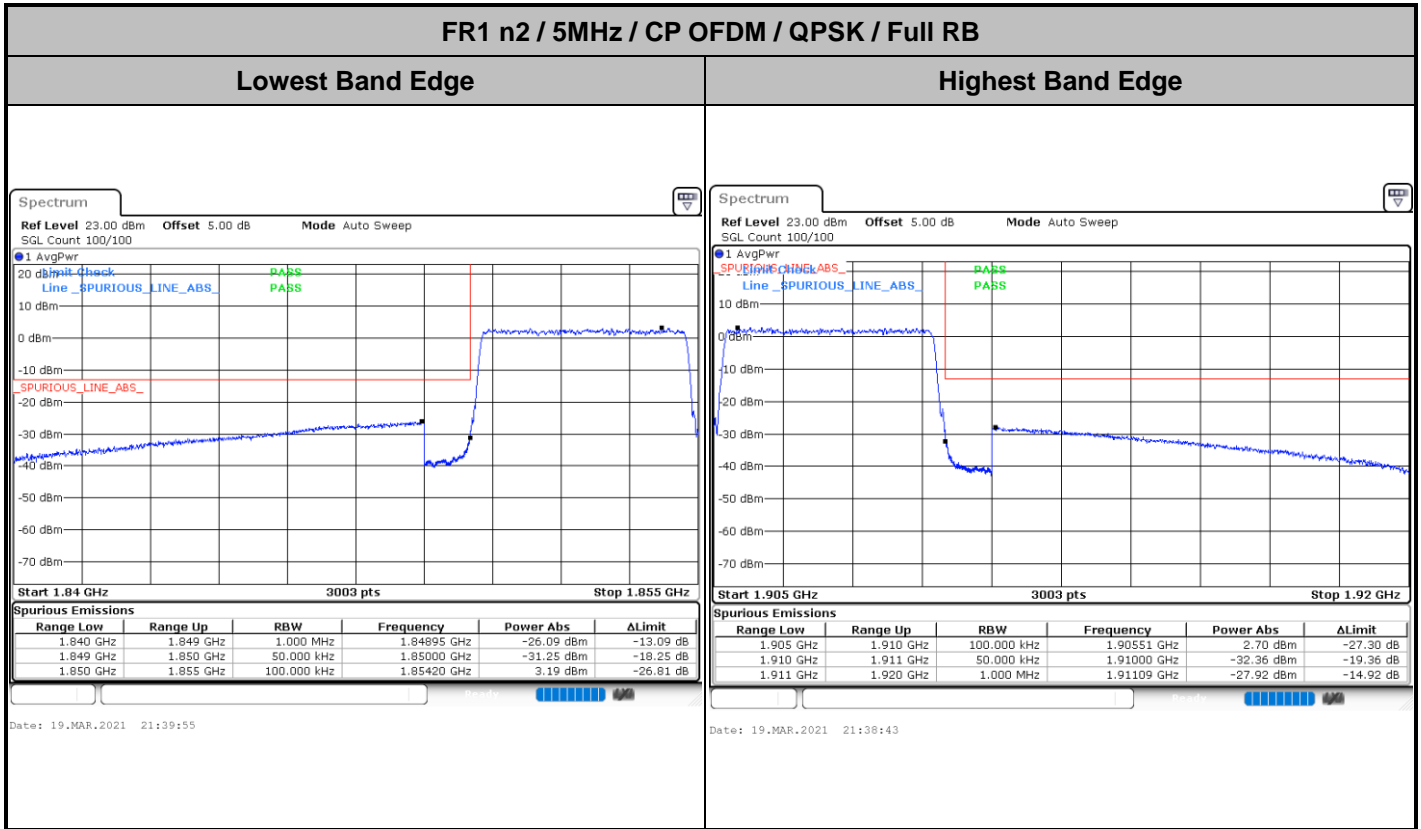



FR1 n2 / 10MHz / DFT-s-OFDM / PI/2 BPSK

Lowest Band Edge / 1RB0

Highest Band Edge / 1RBmax

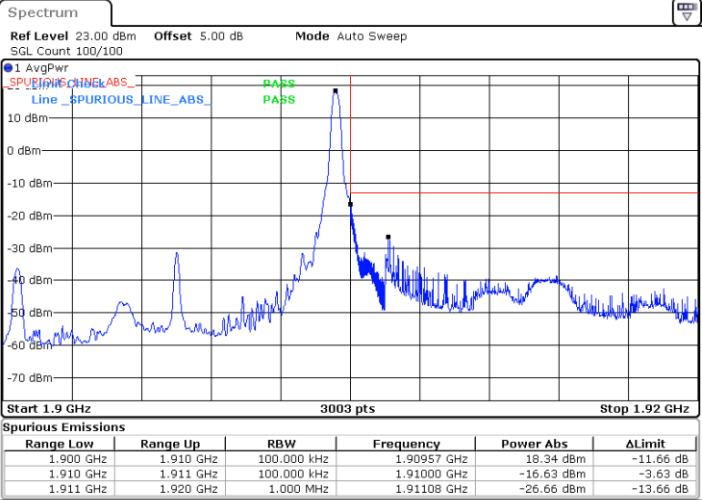
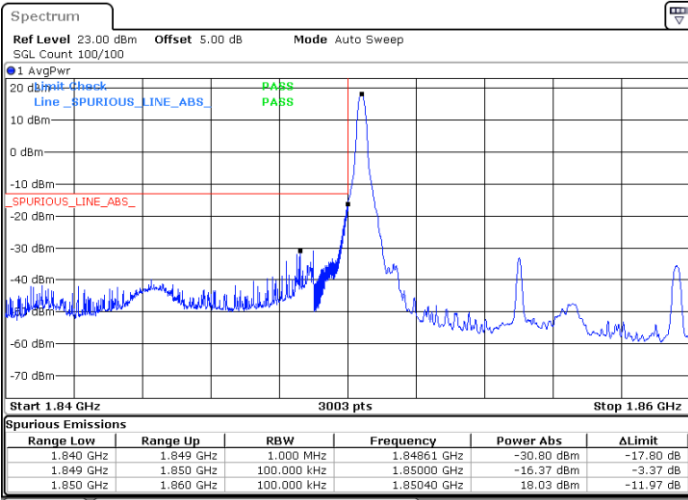

Date: 19.MAR.2021 21:55:23

Date: 19.MAR.2021 22:12:41

Lowest Band Edge / Full RB

Highest Band Edge / Full RB

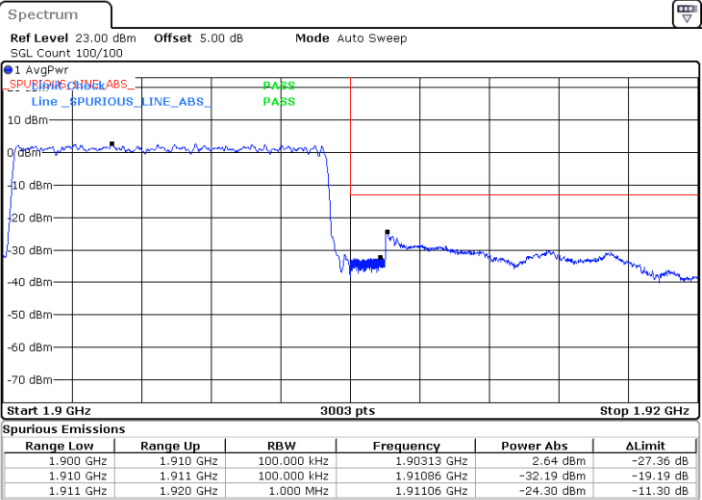
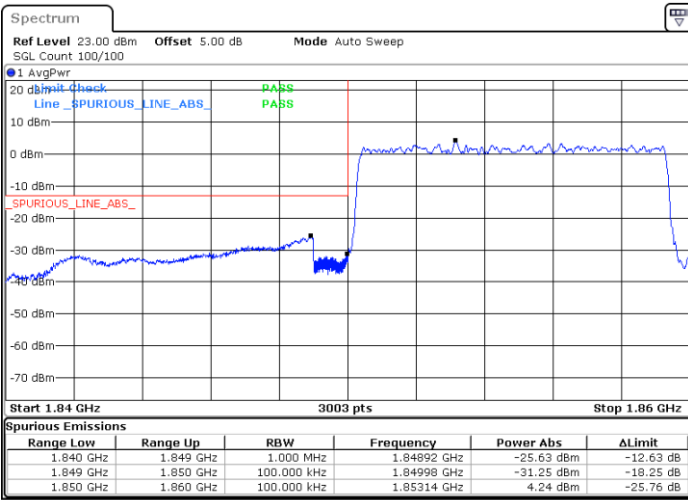

Date: 19.MAR.2021 21:59:24

Date: 19.MAR.2021 22:06:26



FR1 n2 / 10MHz / DFT-s-OFDM / QPSK

Lowest Band Edge / 1RB0

Highest Band Edge / 1RBmax

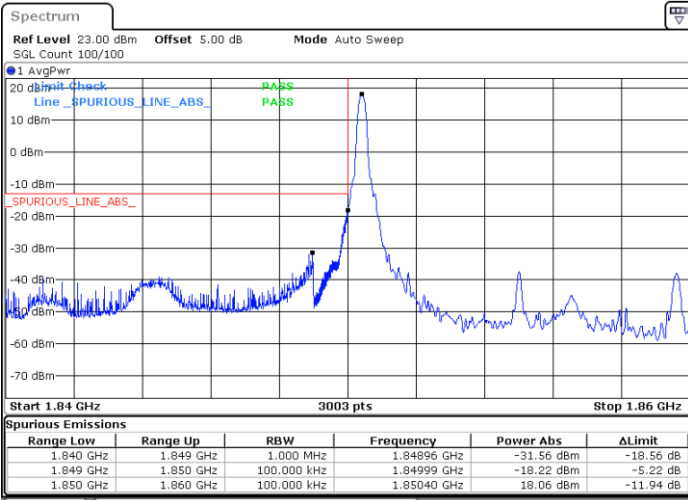

Date: 19.MAR.2021 21:55:56

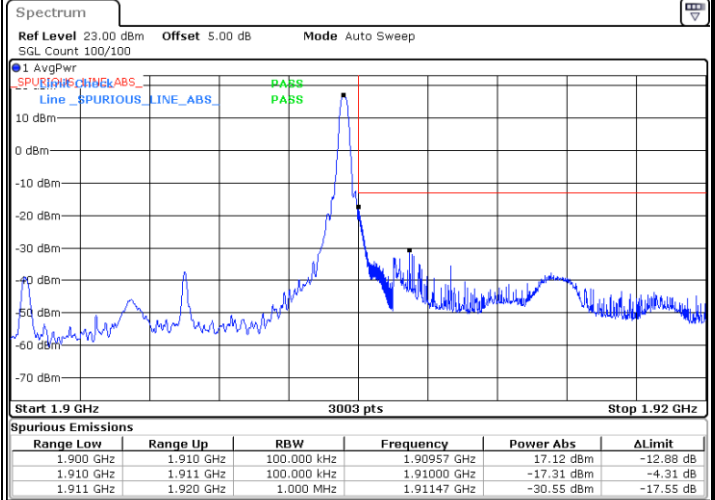

Date: 19.MAR.2021 22:12:03

Lowest Band Edge / Full RB

Highest Band Edge / Full RB

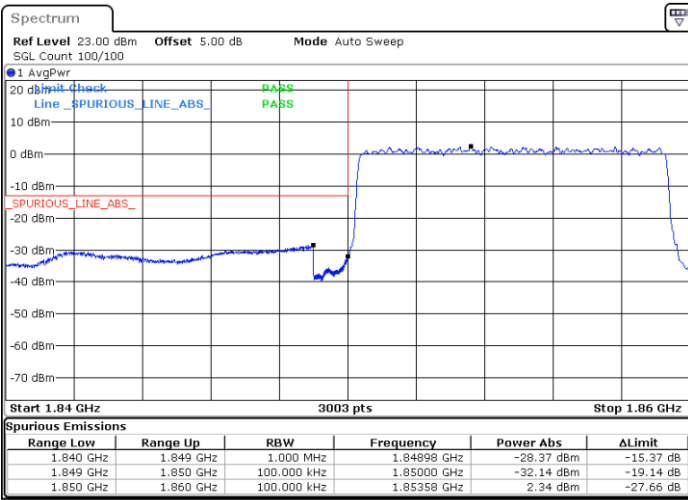

Date: 19.MAR.2021 21:59:12

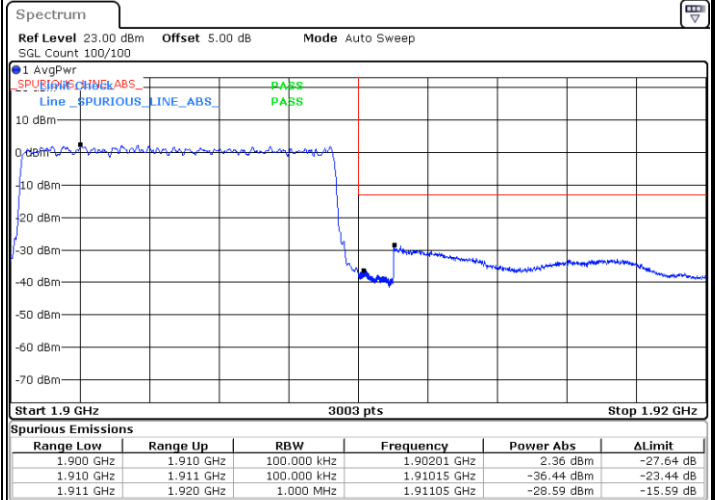

Date: 19.MAR.2021 22:07:03



FR1 n2 / 10MHz / DFT-s-OFDM / 16QAM

Lowest Band Edge / 1RB0

Highest Band Edge / 1RBmax

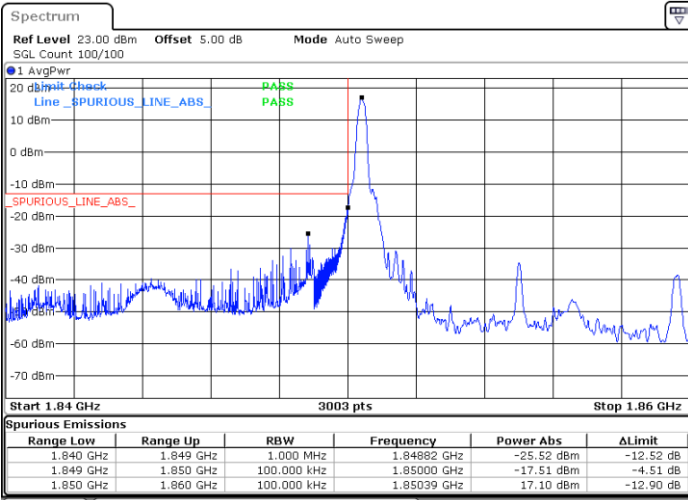

Date: 19.MAR.2021 21:56:17

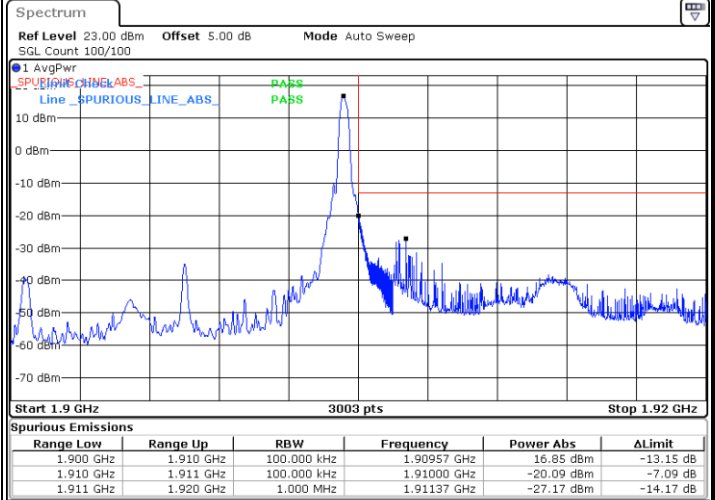

Date: 19.MAR.2021 22:11:37

Lowest Band Edge / Full RB

Highest Band Edge / Full RB

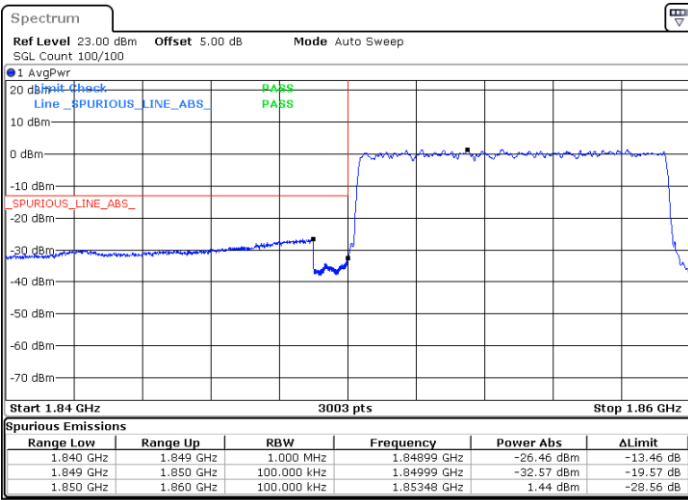

Date: 19.MAR.2021 21:58:43

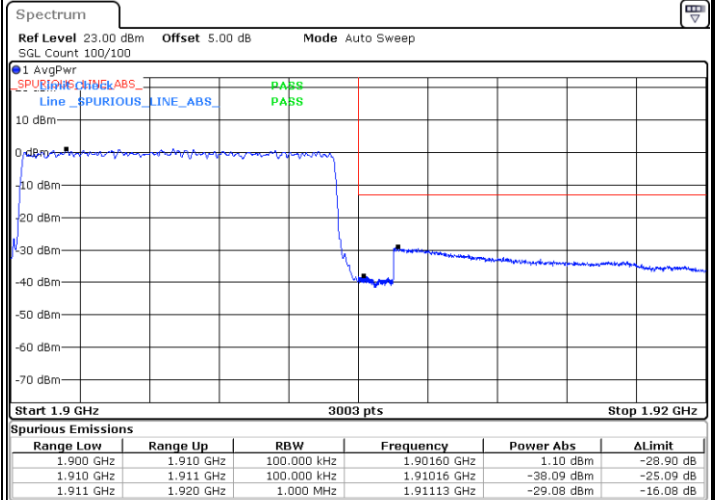

Date: 19.MAR.2021 22:08:10



FR1 n2 / 10MHz / DFT-s-OFDM / 64QAM

Lowest Band Edge / 1RB0

Highest Band Edge / 1RBmax

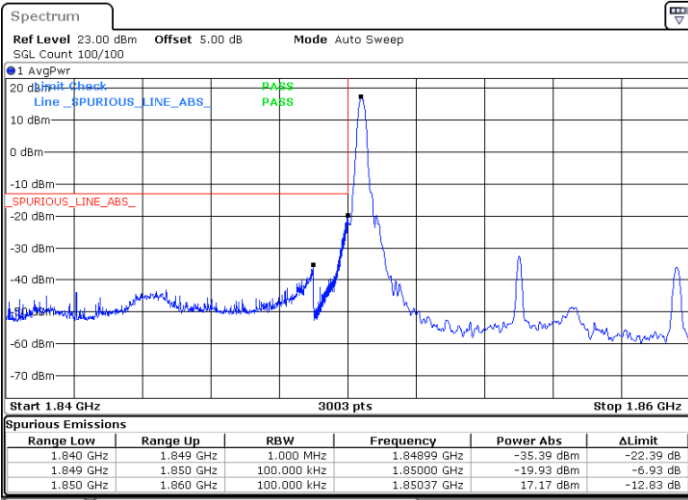

Date: 19.MAR.2021 21:56:39

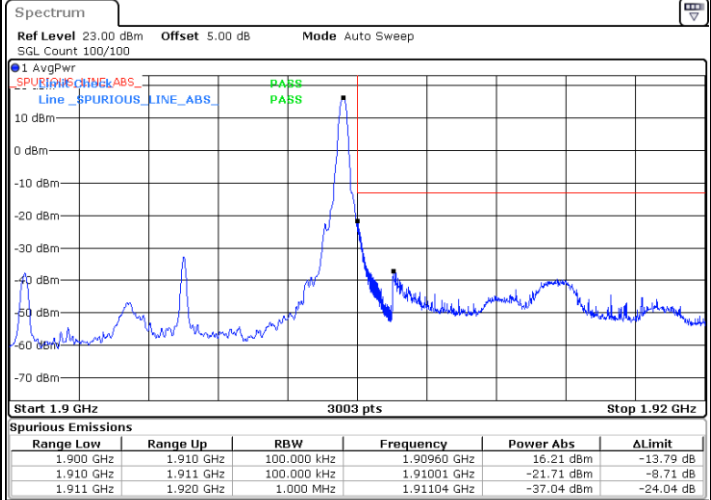

Date: 19.MAR.2021 22:11:15

Lowest Band Edge / Full RB

Highest Band Edge / Full RB

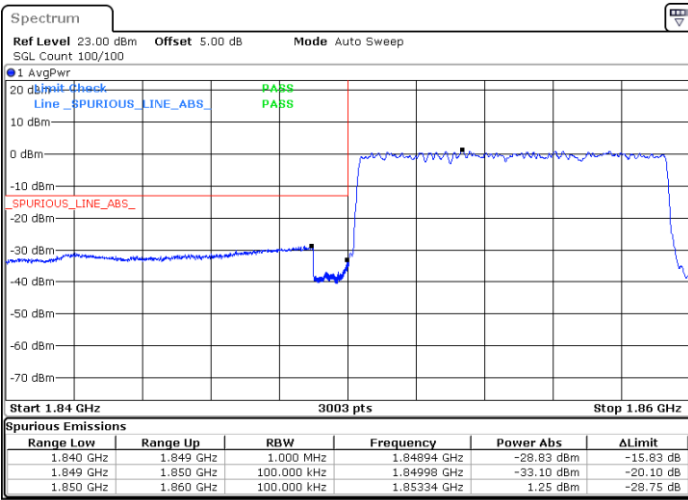

Date: 19.MAR.2021 21:58:21

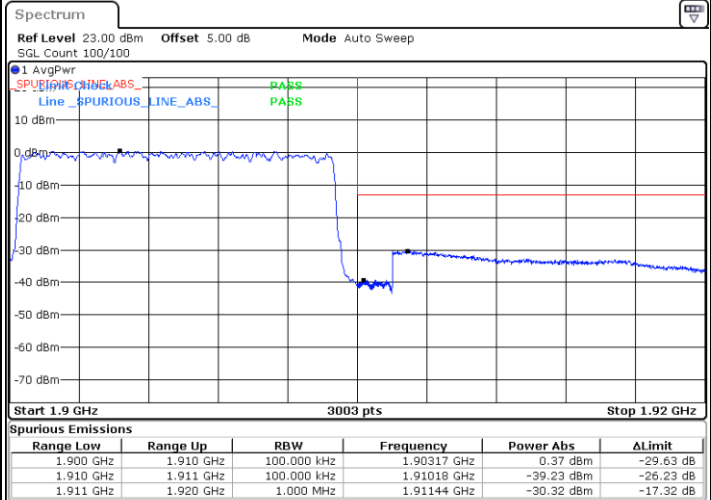

Date: 19.MAR.2021 22:09:16



FR1 n2 / 10MHz / DFT-s-OFDM / 256QAM

Lowest Band Edge / 1RB0

Highest Band Edge / 1RBmax

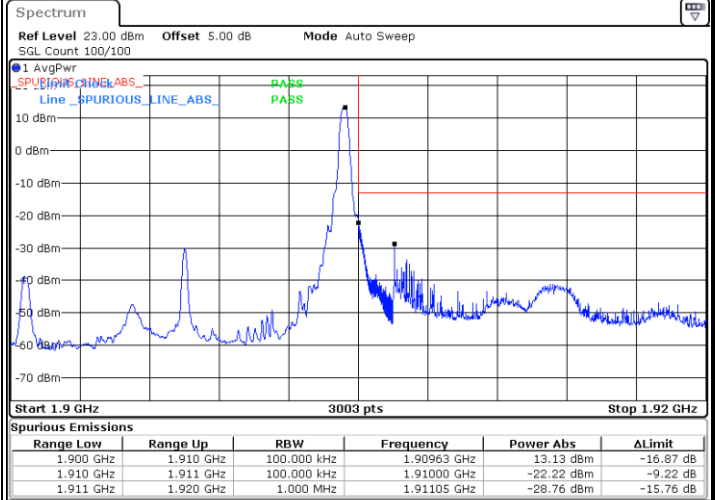
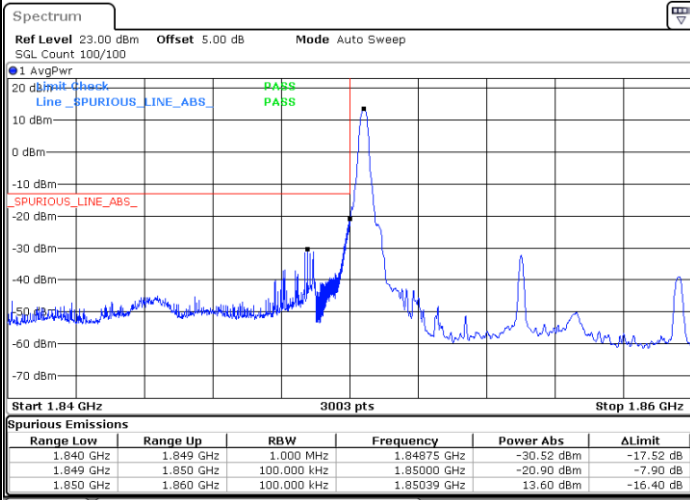

Date: 19.MAR.2021 21:57:05

Date: 19.MAR.2021 22:10:31

Lowest Band Edge / Full RB

Highest Band Edge / Full RB

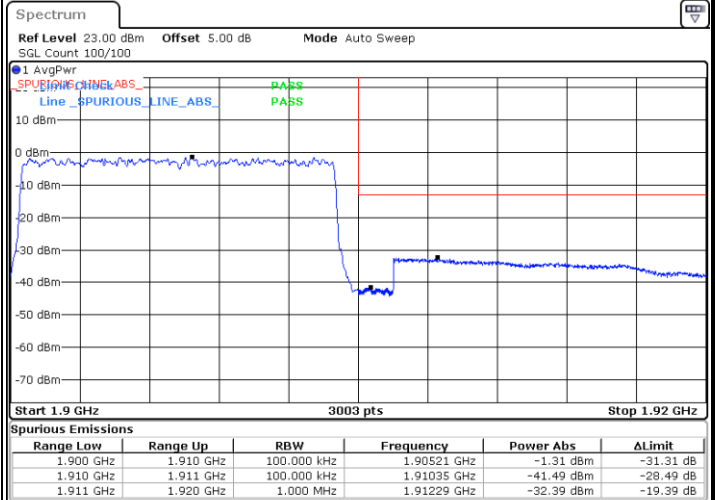
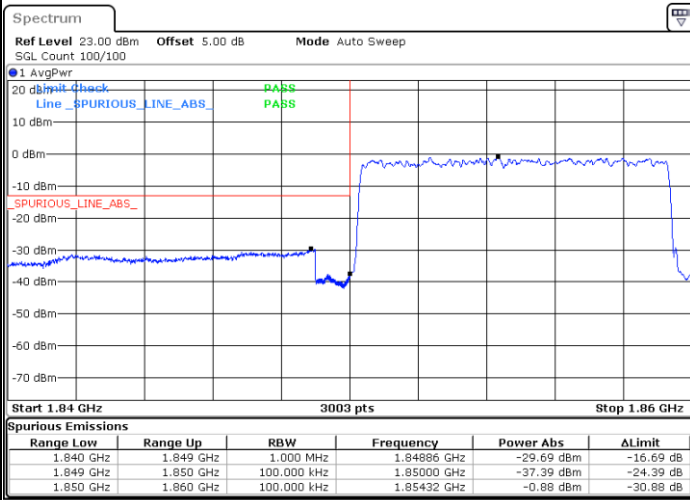

Date: 19.MAR.2021 21:57:34

Date: 19.MAR.2021 22:09:52

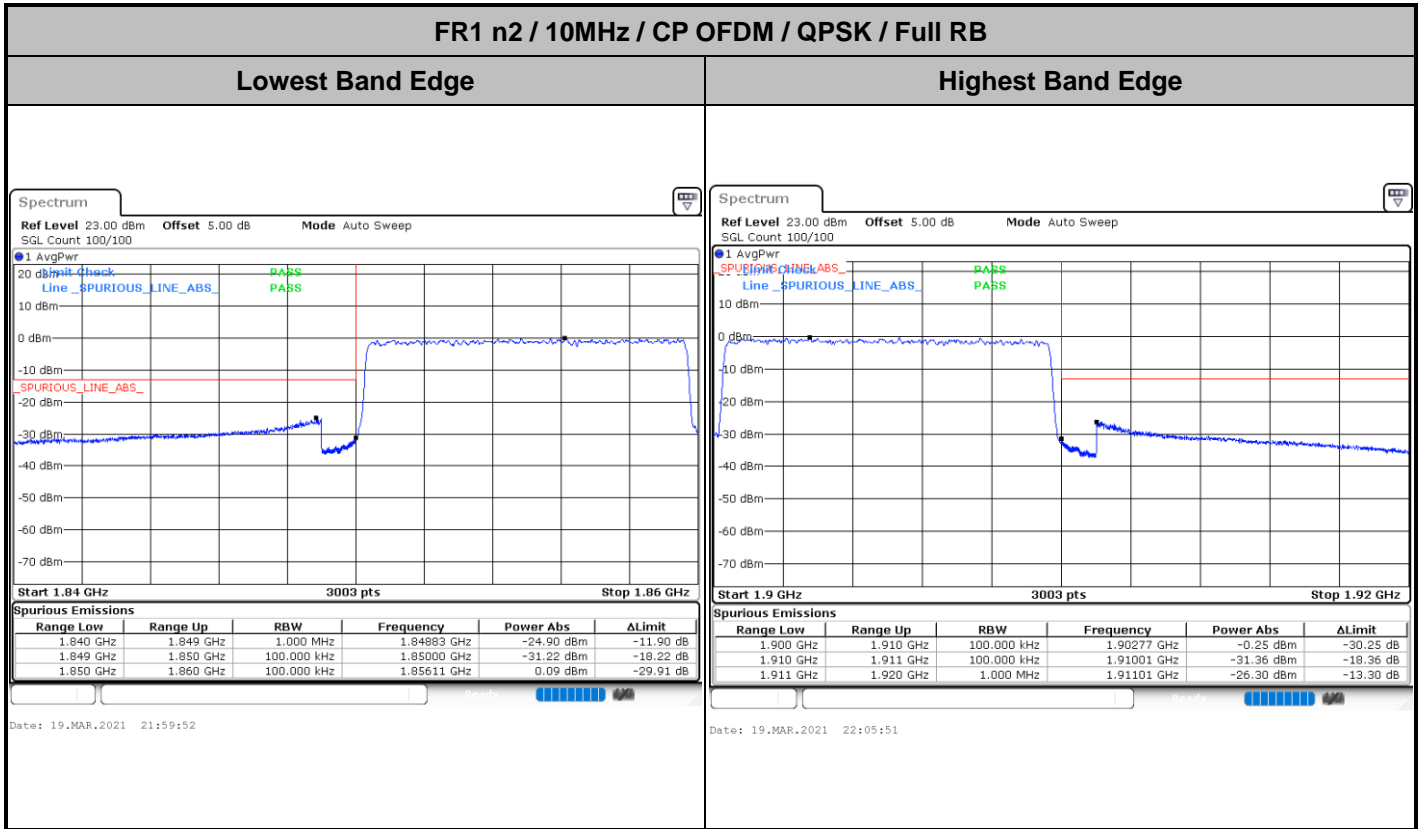



FR1 n2 / 15MHz / DFT-s-OFDM / PI/2 BPSK

Lowest Band Edge / 1RB0

Highest Band Edge / 1RBmax

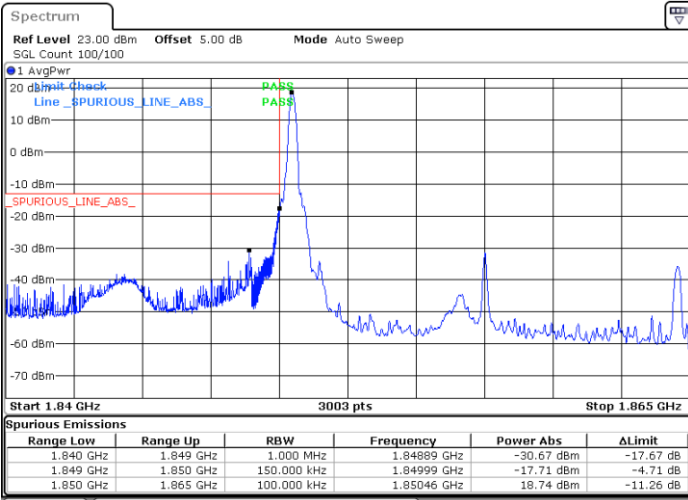

Date: 19.MAR.2021 22:36:28

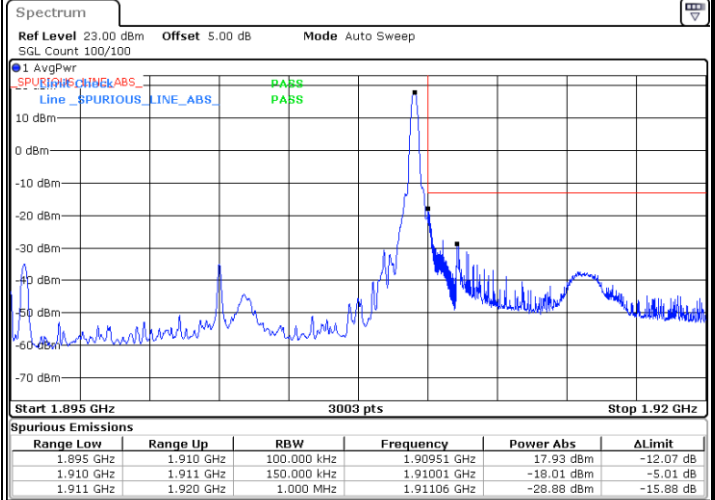

Date: 19.MAR.2021 22:16:53

Lowest Band Edge / Full RB

Highest Band Edge / Full RB

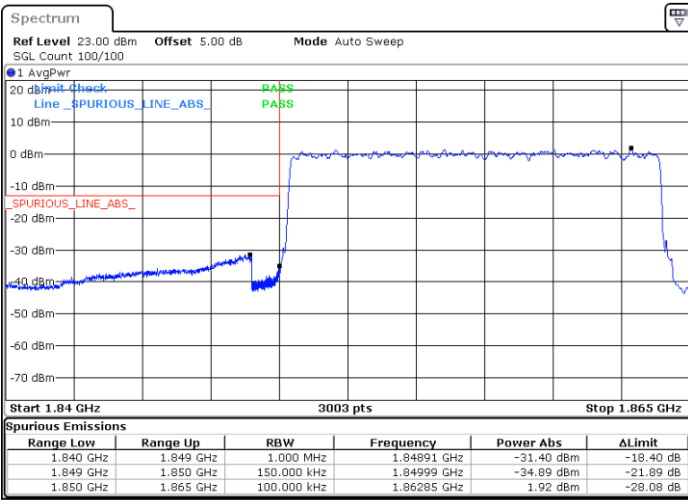

Date: 19.MAR.2021 22:28:20

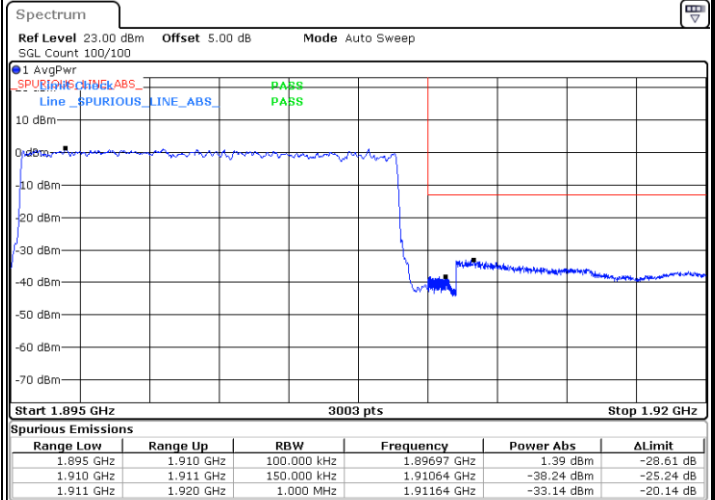

Date: 19.MAR.2021 22:23:28



FR1 n2 / 15MHz / DFT-s-OFDM / QPSK

Lowest Band Edge / 1RB0

Highest Band Edge / 1RBmax

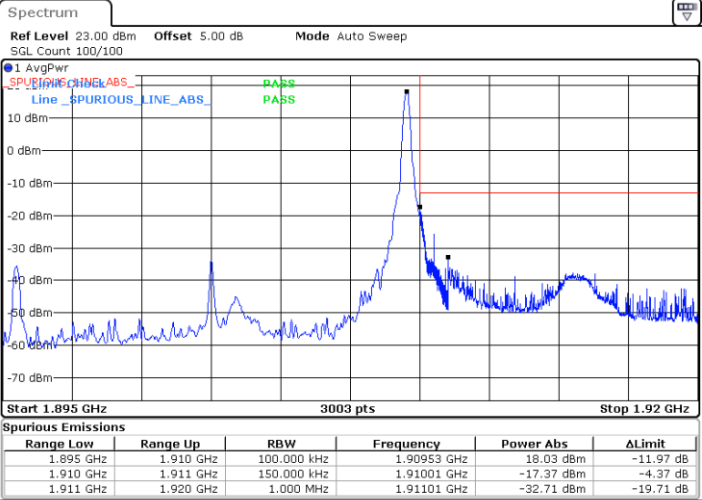
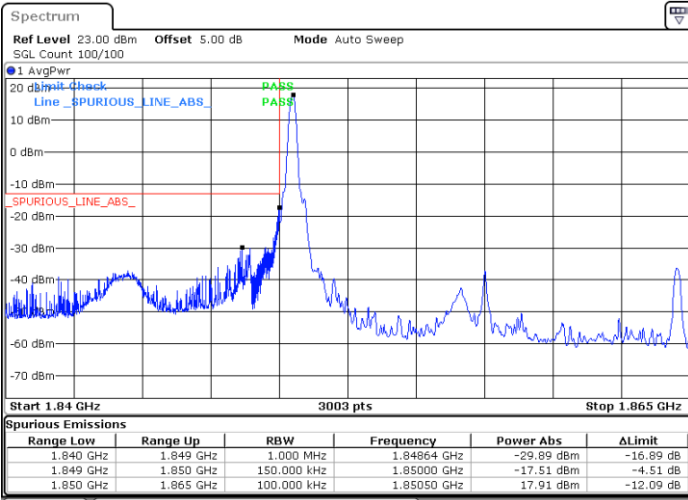

Date: 19.MAR.2021 22:36:09

Date: 19.MAR.2021 22:17:24

Lowest Band Edge / Full RB

Highest Band Edge / Full RB

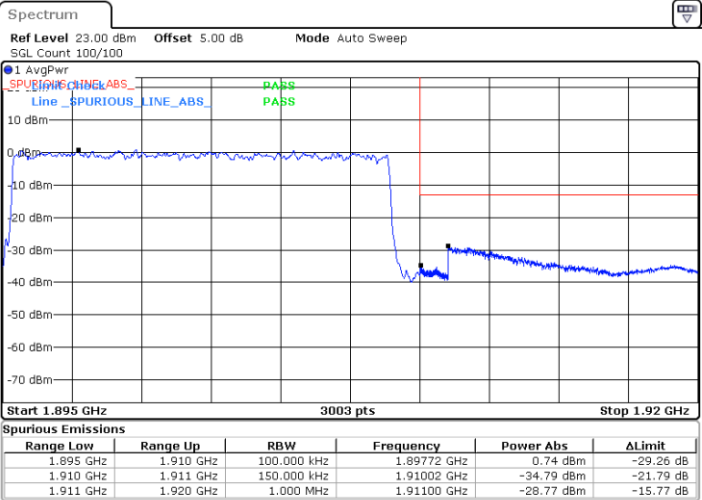
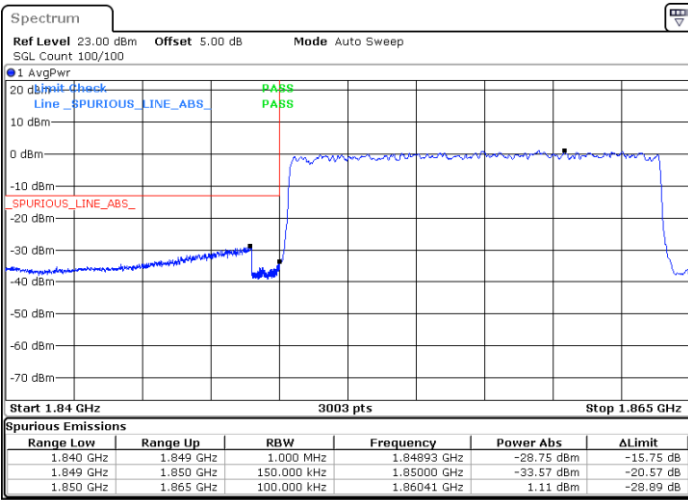

Date: 19.MAR.2021 22:32:55

Date: 19.MAR.2021 22:23:09