

#01_WCDMA II_RMC 12.2Kbps_Back_10mm_Ch9262

Communication System: WCDMA ; Frequency: 1852.4 MHz;Duty Cycle: 1:1

Medium: HSL_1900_200905 Medium parameters used: $f = 1852.4$ MHz; $\sigma = 1.38$ S/m; $\epsilon_r = 39.745$; $\rho = 1000$ kg/m³

Ambient Temperature : 23.5 °C ; Liquid Temperature : 22.5 °C

DASY5 Configuration:

- Probe: ES3DV3 - SN3184; ConvF(5.23, 5.23, 5.23) @ 1852.4 MHz; Calibrated: 2019/9/25
- Sensor-Surface: 3mm (Mechanical Surface Detection)
- Electronics: DAE4 Sn916; Calibrated: 2019/12/17
- Phantom: SAM_Left; Type: QD000P40CD; Serial: TP:1684
- Measurement SW: DASY52, Version 52.10 (4);SEMCAD X Version 14.6.14 (7483)

Area Scan (71x121x1): Interpolated grid: dx=1.500 mm, dy=1.500 mm

Maximum value of SAR (interpolated) = 0.879 W/kg

Zoom Scan (5x5x7)/Cube 0: Measurement grid: dx=8mm, dy=8mm, dz=5mm

Reference Value = 23.72 V/m; Power Drift = -0.13 dB

Peak SAR (extrapolated) = 1.05 W/kg

SAR(1 g) = 0.749 W/kg; SAR(10 g) = 0.494 W/kg

Maximum value of SAR (measured) = 0.861 W/kg

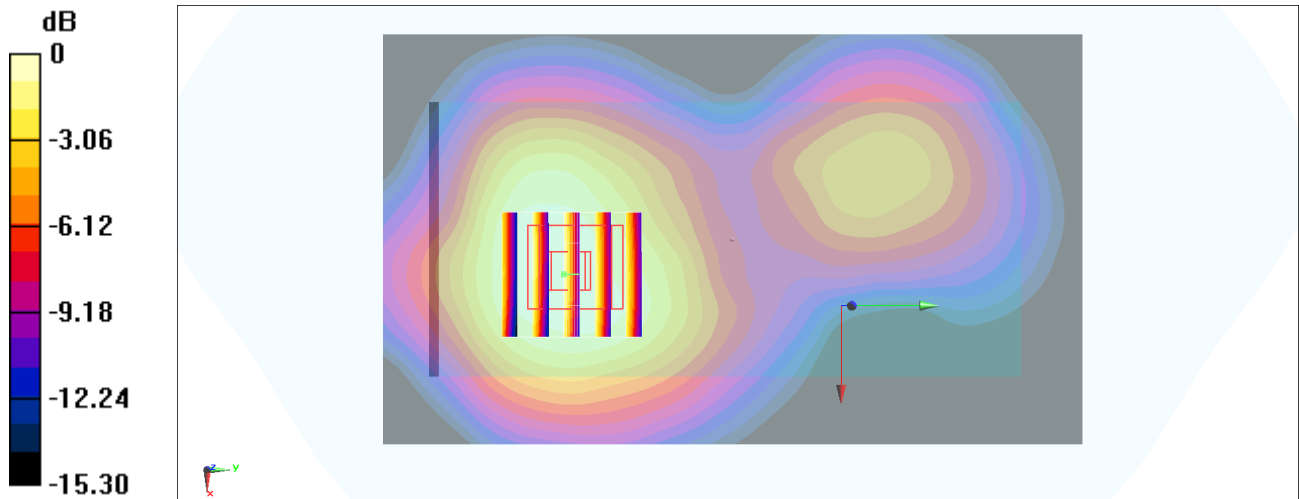

#02_WCDMA IV_RMC 12.2Kbps_Right Side_10mm_Ch1312

Communication System: WCDMA; Frequency: 1712.4 MHz; Duty Cycle: 1:1

Medium: HSL_1750_200904 Medium parameters used: $f = 1712.4$ MHz; $\sigma = 1.345$ S/m; $\epsilon_r = 39.512$; $\rho = 1000$ kg/m³

Ambient Temperature : 23.6 °C ; Liquid Temperature : 22.6 °C

DASY5 Configuration:

- Probe: ES3DV3 - SN3184; ConvF(5.45, 5.45, 5.45) @ 1712.4 MHz; Calibrated: 2019/9/25
- Sensor-Surface: 3mm (Mechanical Surface Detection)
- Electronics: DAE4 Sn916; Calibrated: 2019/12/17
- Phantom: SAM_Left; Type: QD000P40CD; Serial: TP:1684
- Measurement SW: DASY52, Version 52.10 (4); SEMCAD X Version 14.6.14 (7483)

Area Scan (51x71x1): Interpolated grid: dx=1.500 mm, dy=1.500 mm

Maximum value of SAR (interpolated) = 1.28 W/kg

Zoom Scan (5x5x7)/Cube 0: Measurement grid: dx=8mm, dy=8mm, dz=5mm

Reference Value = 17.57 V/m; Power Drift = -0.07 dB

Peak SAR (extrapolated) = 1.35 W/kg

SAR(1 g) = 0.873 W/kg; SAR(10 g) = 0.483 W/kg

Maximum value of SAR (measured) = 1.04 W/kg

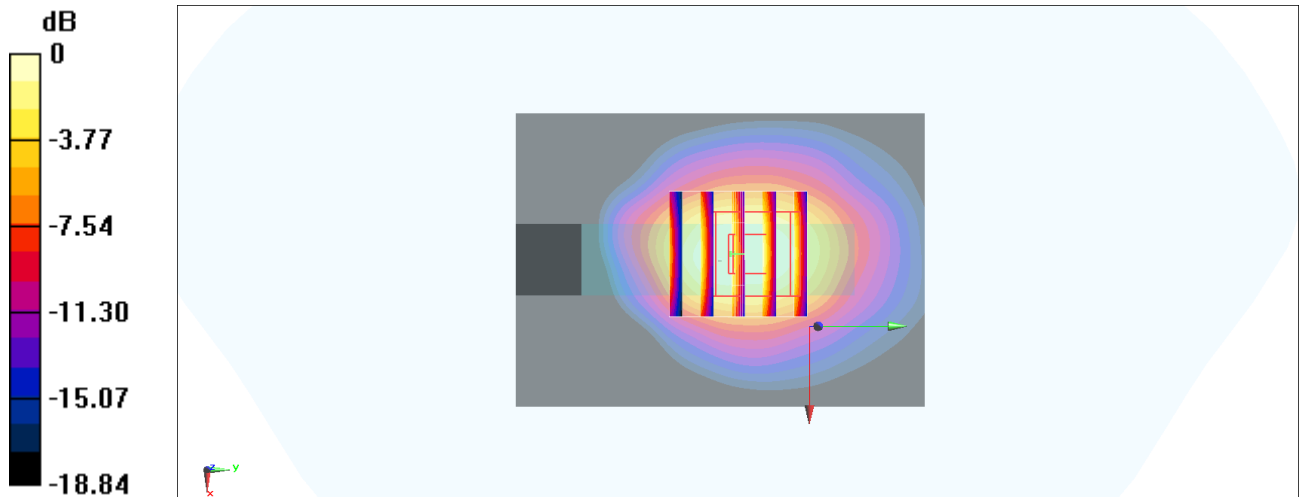

0 dB = 1.04 W/kg = 0.17 dBW/kg

#03_WCDMA V_RMC 12.2Kbps_Back_10mm_Ch4132

Communication System: WCDMA; Frequency: 826.4 MHz; Duty Cycle: 1:1

Medium: HSL_850_200804 Medium parameters used: $f = 826.4$ MHz; $\sigma = 0.875$ S/m; $\epsilon_r = 41.151$; $\rho = 1000$ kg/m³

Ambient Temperature : 23.3 °C ; Liquid Temperature : 22.3 °C

DASY5 Configuration:

- Probe: EX3DV4 - SN3728; ConvF(9.51, 9.51, 9.51) @ 826.4 MHz; Calibrated: 2020/2/4
- Sensor-Surface: 1.4mm (Mechanical Surface Detection)
- Electronics: DAE4 Sn699; Calibrated: 2020/2/26
- Phantom: SAM-Middle; Type: SAM; Serial: TP-1503
- Measurement SW: DASY52, Version 52.10 (4); SEMCAD X Version 14.6.14 (7483)

Area Scan (71x111x1): Interpolated grid: dx=1.500 mm, dy=1.500 mm

Maximum value of SAR (interpolated) = 1.03 W/kg

Zoom Scan (5x5x7)/Cube 0: Measurement grid: dx=8mm, dy=8mm, dz=5mm

Reference Value = 33.66 V/m; Power Drift = -0.13 dB

Peak SAR (extrapolated) = 1.11 W/kg

SAR(1 g) = 0.864 W/kg; SAR(10 g) = 0.578 W/kg

Maximum value of SAR (measured) = 0.989 W/kg

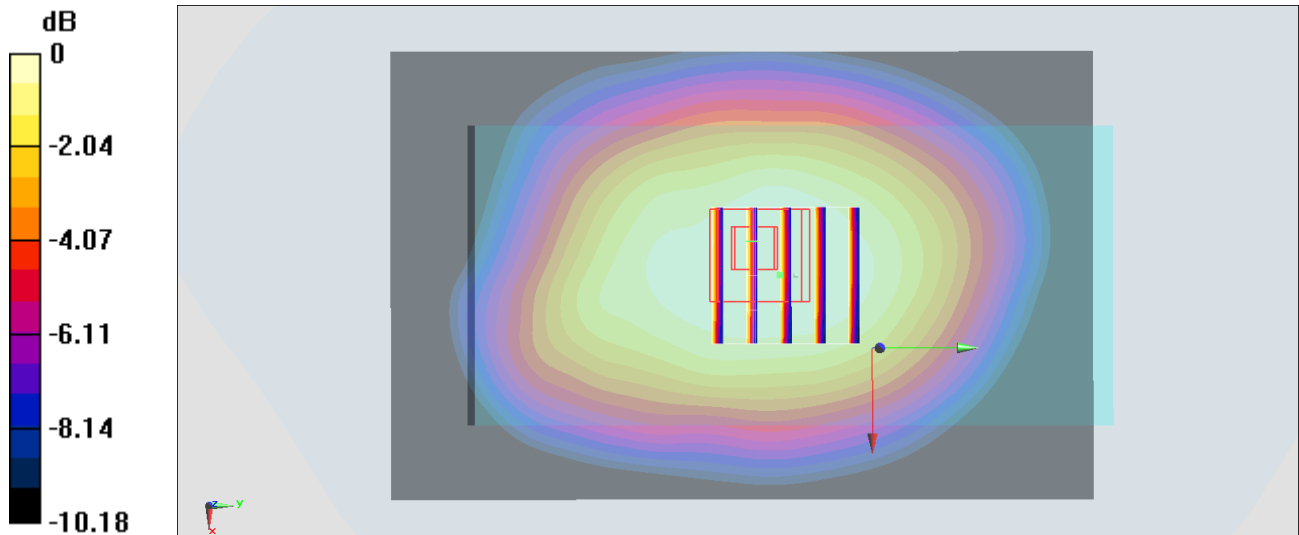

#04_LTE Band 2_20M_QPSK_50_50_Top Side_10mm_Ch18700

Communication System: LTE; Frequency: 1860 MHz; Duty Cycle: 1:1

Medium: HSL_1900_200912 Medium parameters used: $f = 1860$ MHz; $\sigma = 1.376$ S/m; $\epsilon_r = 40.68$; $\rho = 1000$ kg/m³

Ambient Temperature : 23.2 °C; Liquid Temperature : 22.2 °C

DASY5 Configuration:

- Probe: EX3DV4 - SN3642; ConvF(7.75, 7.75, 7.75) @ 1860 MHz; Calibrated: 2020/4/29
- Sensor-Surface: 1.4mm (Mechanical Surface Detection)
- Electronics: DAE4 Sn376; Calibrated: 2019/12/6
- Phantom: SAM_Left; Type: QD000P40CD; Serial: TP:1682
- Measurement SW: DASY52, Version 52.10 (4); SEMCAD X Version 14.6.14 (7483)

Area Scan (61x121x1): Interpolated grid: dx=1.500 mm, dy=1.500 mm

Maximum value of SAR (interpolated) = 1.07 W/kg

Zoom Scan (5x5x7)/Cube 0: Measurement grid: dx=8mm, dy=8mm, dz=5mm

Reference Value = 15.42 V/m; Power Drift = -0.07 dB

Peak SAR (extrapolated) = 1.33 W/kg

SAR(1 g) = 0.743 W/kg; SAR(10 g) = 0.387 W/kg

Maximum value of SAR (measured) = 1.14 W/kg

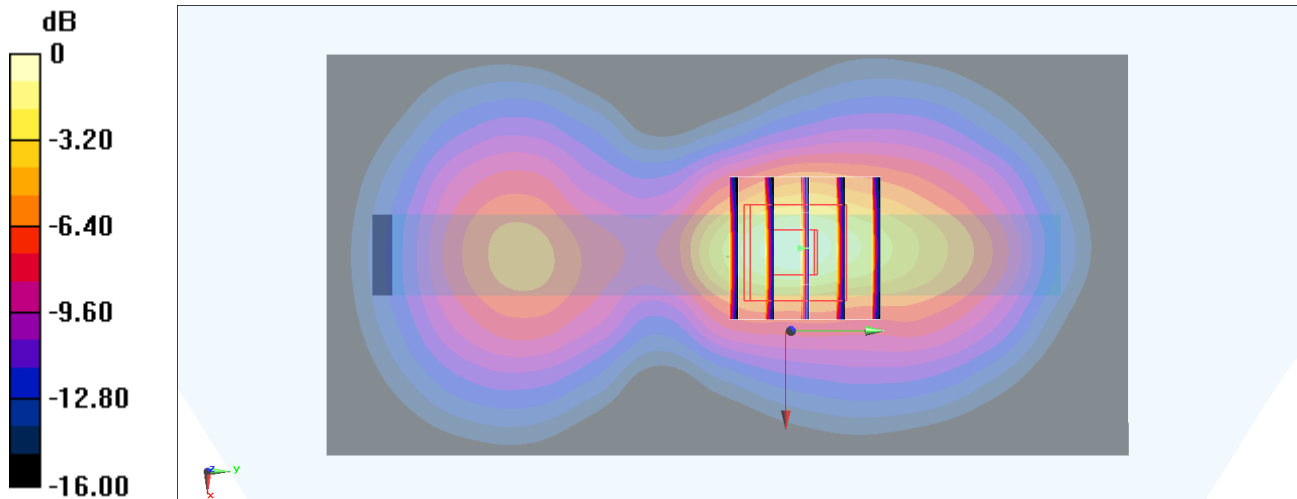

#05_LTE Band 7_20M_QPSK_50_50_Right Side_10mm_Ch20850

Communication System: LTE; Frequency: 2510 MHz; Duty Cycle: 1:1

Medium: HSL_2600_200905 Medium parameters used: $f = 2510$ MHz; $\sigma = 1.944$ S/m; $\epsilon_r = 38.738$; $\rho = 1000$ kg/m³

Ambient Temperature : 23.5 °C ; Liquid Temperature : 22.5 °C

DASY5 Configuration:

- Probe: ES3DV3 - SN3184; ConvF(4.49, 4.49, 4.49) @ 2510 MHz; Calibrated: 2019/9/25
- Sensor-Surface: 3mm (Mechanical Surface Detection)
- Electronics: DAE4 Sn916; Calibrated: 2019/12/17
- Phantom: SAM_Left; Type: QD000P40CD; Serial: TP:1684
- Measurement SW: DASY52, Version 52.10 (4); SEMCAD X Version 14.6.14 (7483)

Area Scan (71x91x1): Interpolated grid: dx=1.200 mm, dy=1.200 mm

Maximum value of SAR (interpolated) = 1.18 W/kg

Zoom Scan (7x7x7)/Cube 0: Measurement grid: dx=5mm, dy=5mm, dz=5mm

Reference Value = 18.33 V/m; Power Drift = -0.05 dB

Peak SAR (extrapolated) = 1.49 W/kg

SAR(1 g) = 0.893 W/kg; SAR(10 g) = 0.443 W/kg

Maximum value of SAR (measured) = 1.11 W/kg

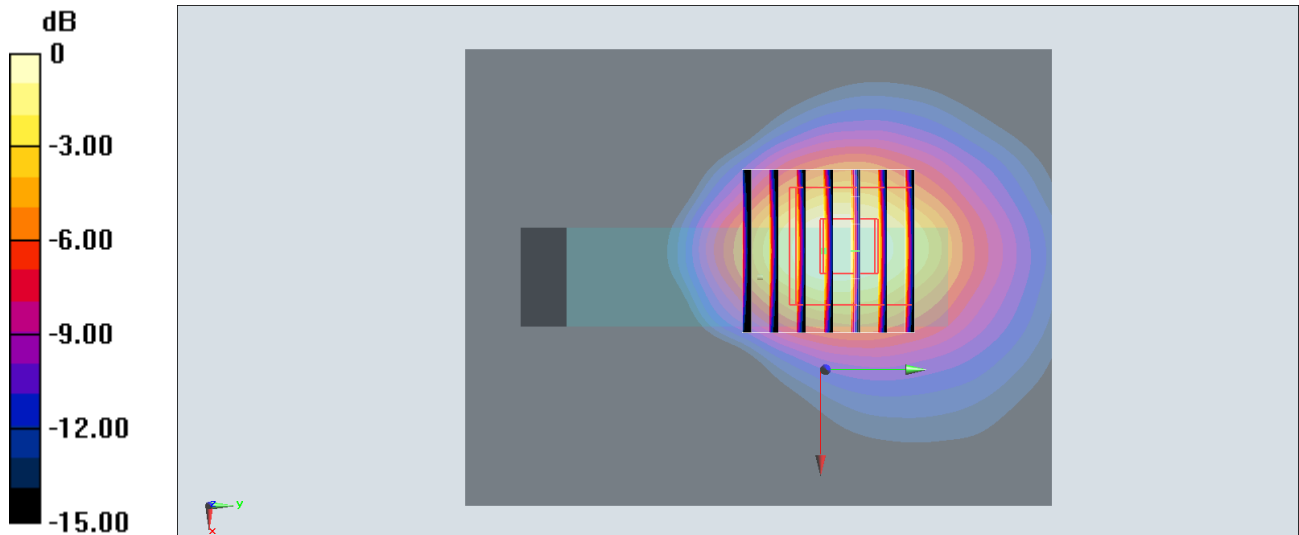

0 dB = 1.11 W/kg = 0.45 dBW/kg

#06_LTE Band 12_10M_QPSK_1_49_Back_10mm_Ch23095

Communication System: LTE; Frequency: 707.5 MHz; Duty Cycle: 1:1

Medium: HSL_750_200805 Medium parameters used : $f = 707.5$ MHz; $\sigma = 0.875$ S/m; $\epsilon_r = 41.483$; $\rho = 1000$ kg/m³

Ambient Temperature : 23.6 °C ; Liquid Temperature : 22.6 °C

DASY5 Configuration:

- Probe: EX3DV4 - SN3728; ConvF(9.67, 9.67, 9.67) @ 707.5 MHz; Calibrated: 2020/2/4
- Sensor-Surface: 1.4mm (Mechanical Surface Detection)
- Electronics: DAE4 Sn699; Calibrated: 2020/2/26
- Phantom: SAM-Middle; Type: SAM; Serial: TP-1503
- Measurement SW: DASY52, Version 52.10 (4); SEMCAD X Version 14.6.14 (7483)

Area Scan (71x71x1): Interpolated grid: dx=1.500 mm, dy=1.500 mm

Maximum value of SAR (interpolated) = 0.980 W/kg

Zoom Scan (5x5x7)/Cube 0: Measurement grid: dx=8mm, dy=8mm, dz=5mm

Reference Value = 34.15 V/m; Power Drift = -0.10 dB

Peak SAR (extrapolated) = 1.07 W/kg

SAR(1 g) = 0.797 W/kg; SAR(10 g) = 0.572 W/kg

Maximum value of SAR (measured) = 0.973 W/kg

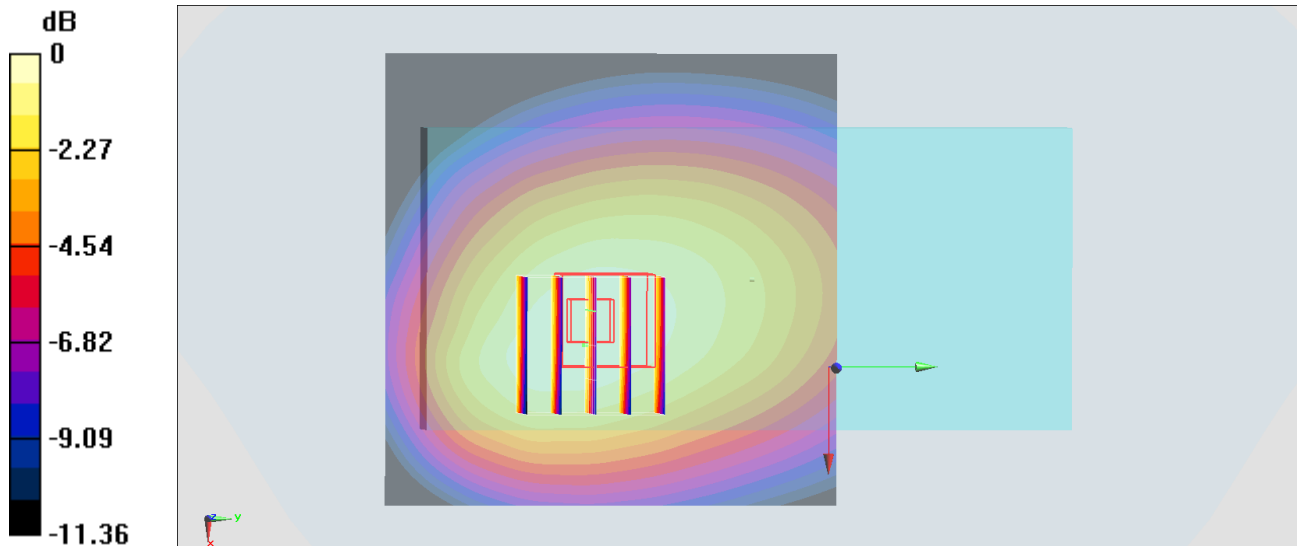

0 dB = 0.973 W/kg = -0.12 dBW/kg

#07_LTE Band 13_10M_QPSK_1_49_Back_10mm_Ch23230

Communication System: LTE; Frequency: 782 MHz; Duty Cycle: 1:1

Medium: HSL_750_200805 Medium parameters used: $f = 782 \text{ MHz}$; $\sigma = 0.898 \text{ S/m}$; $\epsilon_r = 41.219$; $\rho = 1000 \text{ kg/m}^3$

Ambient Temperature : $23.6 \text{ }^\circ\text{C}$; Liquid Temperature : $22.6 \text{ }^\circ\text{C}$

DASY5 Configuration:

- Probe: EX3DV4 - SN3728; ConvF(9.67, 9.67, 9.67) @ 782 MHz; Calibrated: 2020/2/4
- Sensor-Surface: 1.4mm (Mechanical Surface Detection)
- Electronics: DAE4 Sn699; Calibrated: 2020/2/26
- Phantom: SAM-Middle; Type: SAM; Serial: TP-1503
- Measurement SW: DASY52, Version 52.10 (4); SEMCAD X Version 14.6.14 (7483)

Area Scan (71x91x1): Interpolated grid: $dx=1.500 \text{ mm}$, $dy=1.500 \text{ mm}$

Maximum value of SAR (interpolated) = 0.886 W/kg

Zoom Scan (5x5x7)/Cube 0: Measurement grid: $dx=8\text{mm}$, $dy=8\text{mm}$, $dz=5\text{mm}$

Reference Value = 32.08 V/m ; Power Drift = -0.17 dB

Peak SAR (extrapolated) = 0.955 W/kg

SAR(1 g) = 0.744 W/kg ; SAR(10 g) = 0.554 W/kg

Maximum value of SAR (measured) = 0.893 W/kg

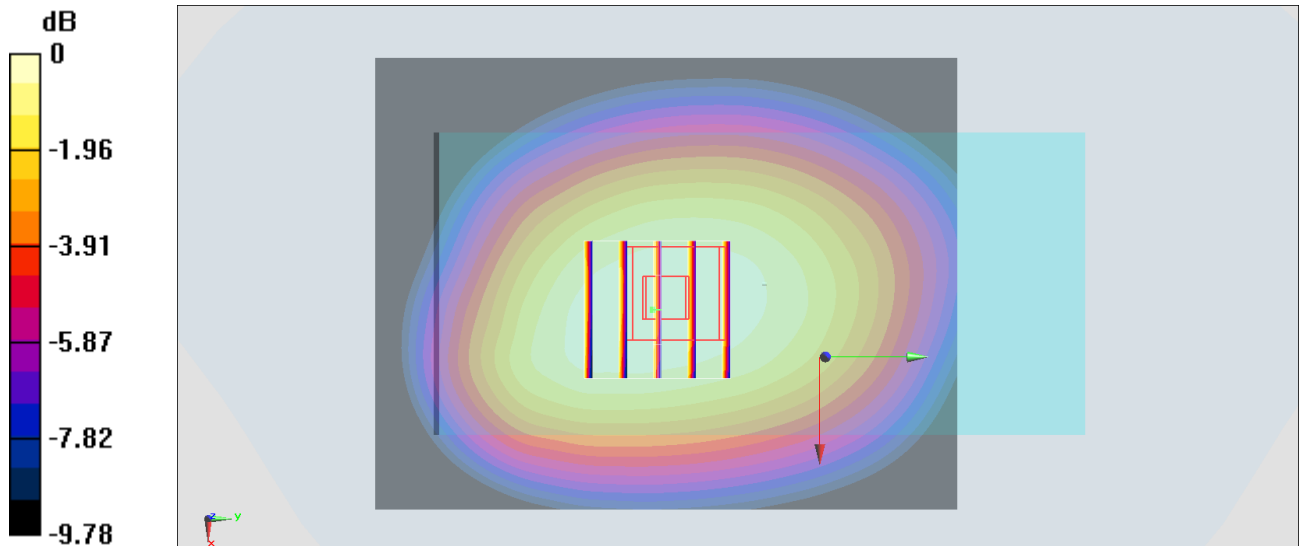

0 dB = $0.893 \text{ W/kg} = -0.49 \text{ dBW/kg}$

#08_LTE Band 14_10M_QPSK_1_0_Back_10mm_Ch23330

Communication System: LTE; Frequency: 793 MHz; Duty Cycle: 1:1

Medium: HSL_750_200805 Medium parameters used: $f = 793$ MHz; $\sigma = 0.902$ S/m; $\epsilon_r = 41.175$; $\rho = 1000$ kg/m³

Ambient Temperature : 23.6 °C ; Liquid Temperature : 22.6 °C

DASY5 Configuration:

- Probe: EX3DV4 - SN3728; ConvF(9.67, 9.67, 9.67) @ 793 MHz; Calibrated: 2020/2/4
- Sensor-Surface: 1.4mm (Mechanical Surface Detection)
- Electronics: DAE4 Sn699; Calibrated: 2020/2/26
- Phantom: SAM-Middle; Type: SAM; Serial: TP-1503
- Measurement SW: DASY52, Version 52.10 (4); SEMCAD X Version 14.6.14 (7483)

Area Scan (71x91x1): Interpolated grid: dx=1.500 mm, dy=1.500 mm

Maximum value of SAR (interpolated) = 0.894 W/kg

Zoom Scan (5x5x7)/Cube 0: Measurement grid: dx=8mm, dy=8mm, dz=5mm

Reference Value = 32.60 V/m; Power Drift = -0.04 dB

Peak SAR (extrapolated) = 0.983 W/kg

SAR(1 g) = 0.760 W/kg; SAR(10 g) = 0.563 W/kg

Maximum value of SAR (measured) = 0.911 W/kg

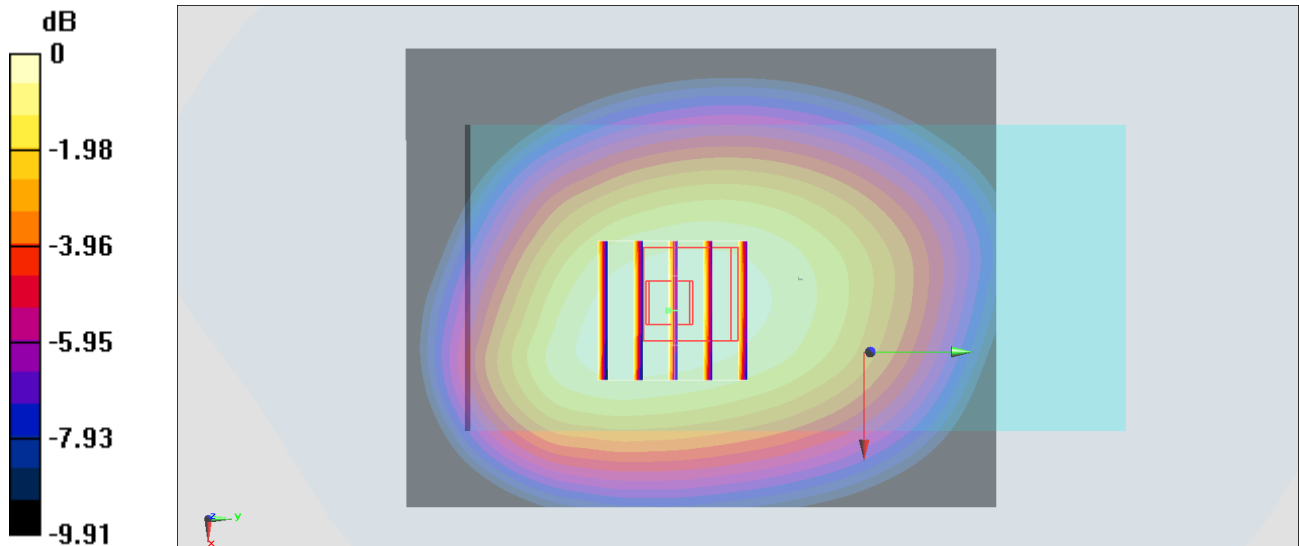

0 dB = 0.911 W/kg = -0.40 dBW/kg

#09_LTE Band 25_20M_QPSK_1_49_Back_10mm_Ch26140

Communication System: LTE; Frequency: 1860 MHz; Duty Cycle: 1:1

Medium: HSL_1900_200904 Medium parameters used: $f = 1860$ MHz; $\sigma = 1.39$ S/m; $\epsilon_r = 39.775$; $\rho = 1000$ kg/m³

Ambient Temperature : 23.6 °C ; Liquid Temperature : 22.6 °C

DASY5 Configuration:

- Probe: ES3DV3 - SN3184; ConvF(5.23, 5.23, 5.23) @ 1860 MHz; Calibrated: 2019/9/25
- Sensor-Surface: 3mm (Mechanical Surface Detection)
- Electronics: DAE4 Sn916; Calibrated: 2019/12/17
- Phantom: SAM_Left; Type: QD000P40CD; Serial: TP:1684
- Measurement SW: DASY52, Version 52.10 (4); SEMCAD X Version 14.6.14 (7483)

Area Scan (71x71x1): Interpolated grid: dx=1.500 mm, dy=1.500 mm

Maximum value of SAR (interpolated) = 0.899 W/kg

Zoom Scan (5x5x7)/Cube 0: Measurement grid: dx=8mm, dy=8mm, dz=5mm

Reference Value = 22.47 V/m; Power Drift = -0.01 dB

Peak SAR (extrapolated) = 1.10 W/kg

SAR(1 g) = 0.770 W/kg; SAR(10 g) = 0.502 W/kg

Maximum value of SAR (measured) = 0.873 W/kg

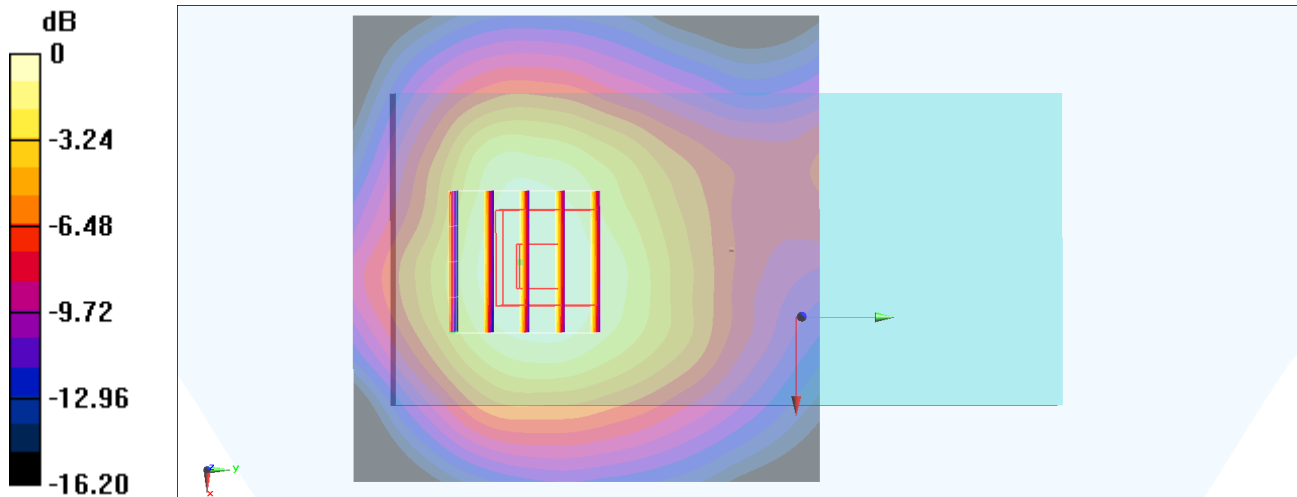

0 dB = 0.873 W/kg = -0.59 dBW/kg

#10_LTE Band 26_15M_QPSK_1_0_Back_10mm_Ch26865

Communication System: LTE; Frequency: 831.5 MHz; Duty Cycle: 1:1

Medium: HSL_850_200806 Medium parameters used : $f = 831.5$ MHz; $\sigma = 0.88$ S/m; $\epsilon_r = 41.106$; $\rho = 1000$ kg/m³

Ambient Temperature : 23.2 °C ; Liquid Temperature : 22.2 °C

DASY5 Configuration:

- Probe: EX3DV4 - SN3728; ConvF(9.51, 9.51, 9.51) @ 831.5 MHz; Calibrated: 2020/2/4
- Sensor-Surface: 1.4mm (Mechanical Surface Detection)
- Electronics: DAE4 Sn699; Calibrated: 2020/2/26
- Phantom: SAM-Middle; Type: SAM; Serial: TP-1503
- Measurement SW: DASY52, Version 52.10 (4); SEMCAD X Version 14.6.14 (7483)

Area Scan (71x91x1): Interpolated grid: dx=1.500 mm, dy=1.500 mm

Maximum value of SAR (interpolated) = 1.03 W/kg

Zoom Scan (5x5x7)/Cube 0: Measurement grid: dx=8mm, dy=8mm, dz=5mm

Reference Value = 33.20 V/m; Power Drift = -0.08 dB

Peak SAR (extrapolated) = 1.09 W/kg

SAR(1 g) = 0.850 W/kg; SAR(10 g) = 0.634 W/kg

Maximum value of SAR (measured) = 1.01 W/kg

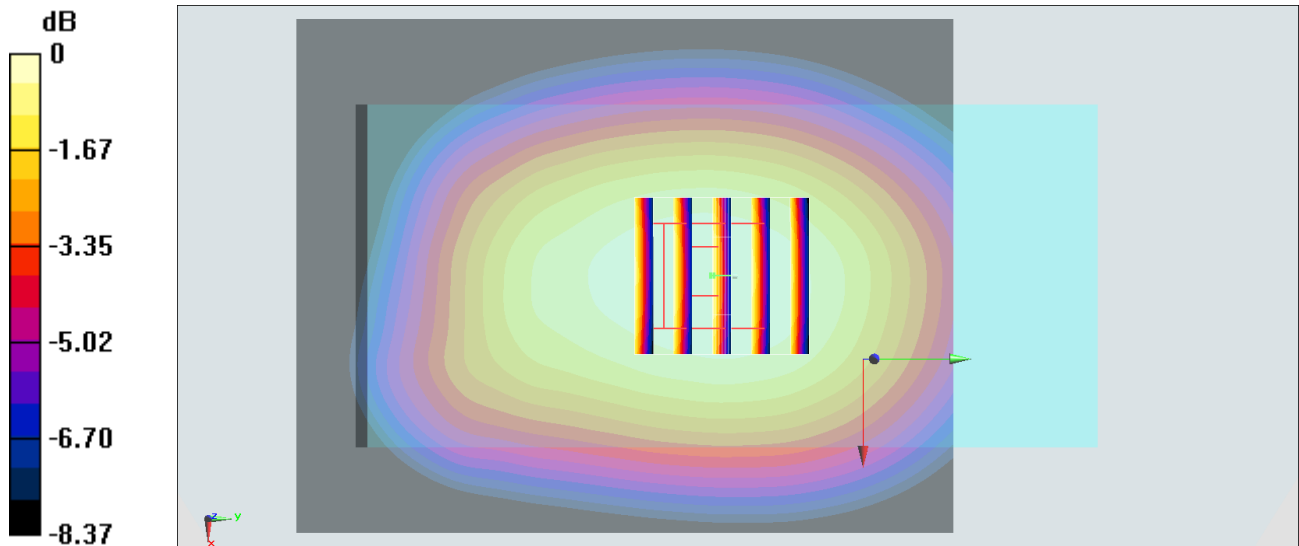

0 dB = 1.01 W/kg = 0.04 dBW/kg

#11_LTE Band 30_10M_QPSK_1_25_Right Side_10mm_Ch27710

Communication System: LTE; Frequency: 2310 MHz; Duty Cycle: 1:1

Medium: HSL_2300_200912 Medium parameters used: $f = 2310$ MHz; $\sigma = 1.668$ S/m; $\epsilon_r = 39.713$; $\rho = 1000$ kg/m³

Ambient Temperature : 23.2 °C; Liquid Temperature : 22.2 °C

DASY5 Configuration:

- Probe: EX3DV4 - SN3642; ConvF(7.38, 7.38, 7.38) @ 2310 MHz; Calibrated: 2020/4/29
- Sensor-Surface: 1.4mm (Mechanical Surface Detection)
- Electronics: DAE4 Sn376; Calibrated: 2019/12/6
- Phantom: SAM_Left; Type: QD000P40CD; Serial: TP:1682
- Measurement SW: DASY52, Version 52.10 (4); SEMCAD X Version 14.6.14 (7483)

Area Scan (61x101x1): Interpolated grid: dx=1.200 mm, dy=1.200 mm

Maximum value of SAR (interpolated) = 1.42 W/kg

Zoom Scan (7x7x7)/Cube 0: Measurement grid: dx=5mm, dy=5mm, dz=5mm

Reference Value = 20.13 V/m; Power Drift = -0.13 dB

Peak SAR (extrapolated) = 1.61 W/kg

SAR(1 g) = 0.874 W/kg; SAR(10 g) = 0.452 W/kg

Maximum value of SAR (measured) = 1.31 W/kg

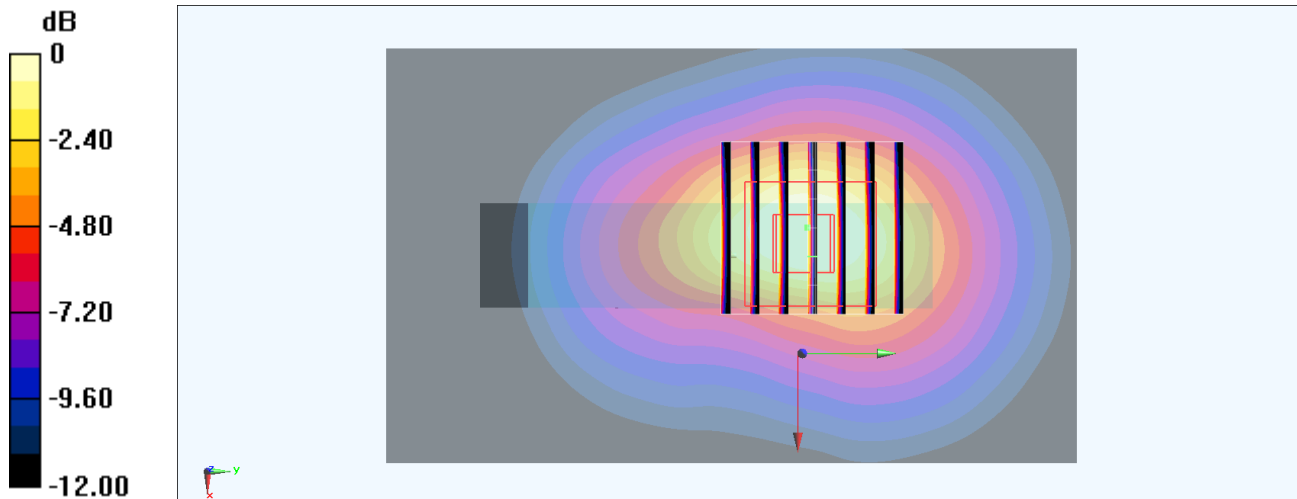

0 dB = 1.31 W/kg = 1.17 dBW/kg

#12_LTE Band 66_20M_QPSK_1_0_Right Side_10mm_Ch132072

Communication System: LTE ; Frequency: 1720 MHz;Duty Cycle: 1:1

Medium: HSL_1750_200914 Medium parameters used: $f = 1720$ MHz; $\sigma = 1.351$ S/m; $\epsilon_r = 41.631$; $\rho = 1000$ kg/m³

Ambient Temperature : 23.3 °C ; Liquid Temperature : 22.3 °C

DASY5 Configuration:

- Probe: ES3DV3 - SN3071; ConvF(4.95, 4.95, 4.95) @ 1720 MHz; Calibrated: 2019/12/18
- Sensor-Surface: 3mm (Mechanical Surface Detection)
- Electronics: DAE4 Sn916; Calibrated: 2019/12/17
- Phantom: SAM_Left; Type: QD000P40CD; Serial: TP:1684
- Measurement SW: DASY52, Version 52.10 (4);SEMCAD X Version 14.6.14 (7483)

Area Scan (51x71x1): Interpolated grid: dx=1.500 mm, dy=1.500 mm

Maximum value of SAR (interpolated) = 1.05 W/kg

Zoom Scan (5x5x7)/Cube 0: Measurement grid: dx=8mm, dy=8mm, dz=5mm

Reference Value = 26.79 V/m; Power Drift = 0.01 dB

Peak SAR (extrapolated) = 1.31 W/kg

SAR(1 g) = 0.784 W/kg; SAR(10 g) = 0.422 W/kg

Maximum value of SAR (measured) = 0.886 W/kg

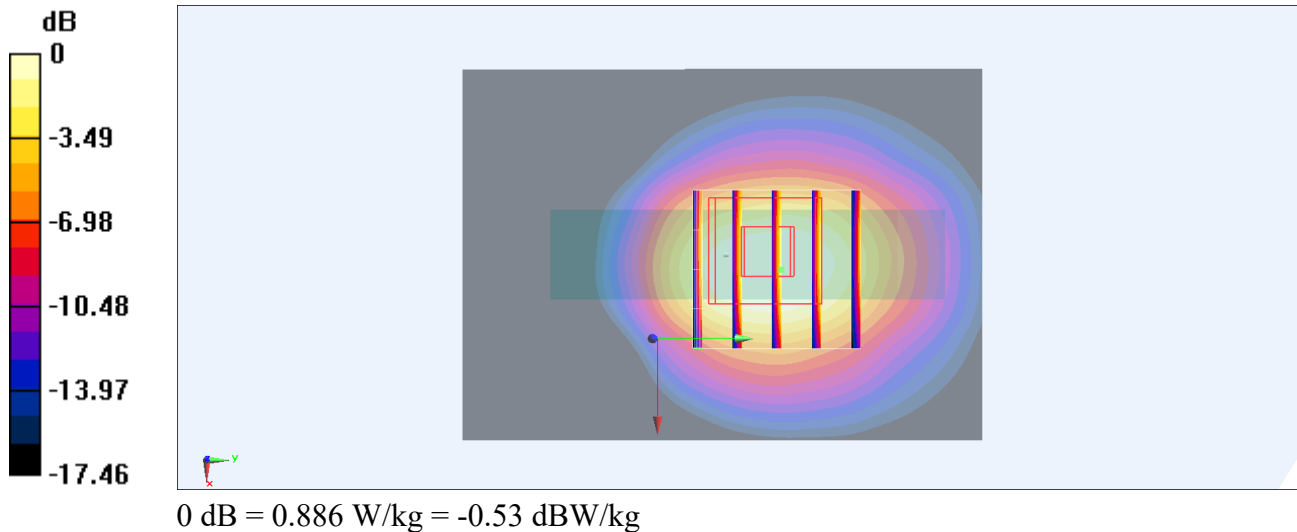

#13_LTE Band 71_20M_QPSK_1_0_Front_10mm_Ch133322

Communication System: LTE; Frequency: 683 MHz; Duty Cycle: 1:1

Medium: HSL_750_200805 Medium parameters used: $f = 683$ MHz; $\sigma = 0.866$ S/m; $\epsilon_r = 41.583$; $\rho = 1000$ kg/m³

Ambient Temperature : 23.6 °C ; Liquid Temperature : 22.6 °C

DASY5 Configuration:

- Probe: EX3DV4 - SN3728; ConvF(9.67, 9.67, 9.67) @ 683 MHz; Calibrated: 2020/2/4
- Sensor-Surface: 1.4mm (Mechanical Surface Detection)
- Electronics: DAE4 Sn699; Calibrated: 2020/2/26
- Phantom: SAM-Middle; Type: SAM; Serial: TP-1503
- Measurement SW: DASY52, Version 52.10 (4); SEMCAD X Version 14.6.14 (7483)

Area Scan (71x91x1): Interpolated grid: dx=1.500 mm, dy=1.500 mm

Maximum value of SAR (interpolated) = 0.874 W/kg

Zoom Scan (5x5x7)/Cube 0: Measurement grid: dx=8mm, dy=8mm, dz=5mm

Reference Value = 30.70 V/m; Power Drift = -0.12 dB

Peak SAR (extrapolated) = 0.925 W/kg

SAR(1 g) = 0.729 W/kg; SAR(10 g) = 0.548 W/kg

Maximum value of SAR (measured) = 0.865 W/kg

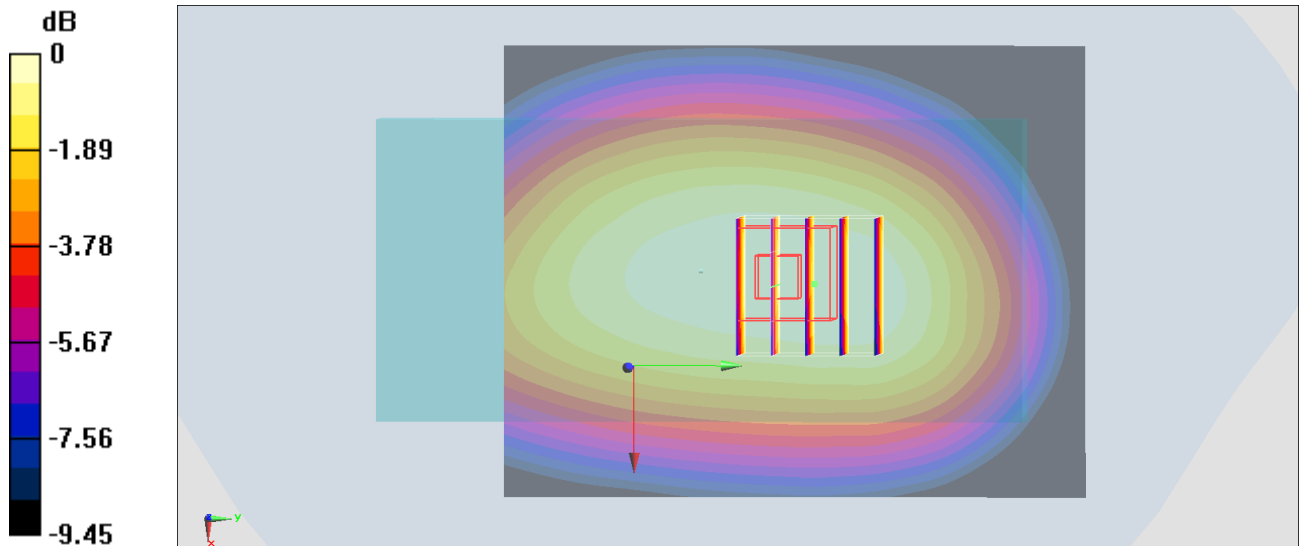

#14_LTE Band 41_20M_QPSK_50_24_Right Side_10mm_Ch39750

Communication System: LTE; Frequency: 2506 MHz; Duty Cycle: 1:1.59

Medium: HSL_2600_200912 Medium parameters used: $f = 2506$ MHz; $\sigma = 1.88$ S/m; $\epsilon_r = 39.027$; $\rho = 1000$ kg/m³

Ambient Temperature : 23.2 °C ; Liquid Temperature : 22.2 °C

DASY5 Configuration:

- Probe: EX3DV4 - SN3642; ConvF(6.95, 6.95, 6.95) @ 2506 MHz; Calibrated: 2020/4/29
- Sensor-Surface: 1.4mm (Mechanical Surface Detection)
- Electronics: DAE4 Sn376; Calibrated: 2019/12/6
- Phantom: SAM_Left; Type: QD000P40CD; Serial: TP:1682
- Measurement SW: DASY52, Version 52.10 (4); SEMCAD X Version 14.6.14 (7483)

Area Scan (61x101x1): Interpolated grid: dx=1.200 mm, dy=1.200 mm

Maximum value of SAR (interpolated) = 1.38 W/kg

Zoom Scan (7x7x7)/Cube 0: Measurement grid: dx=5mm, dy=5mm, dz=5mm

Reference Value = 12.01 V/m; Power Drift = -0.06 dB

Peak SAR (extrapolated) = 1.54 W/kg

SAR(1 g) = 0.815 W/kg; SAR(10 g) = 0.393 W/kg

Maximum value of SAR (measured) = 1.26 W/kg

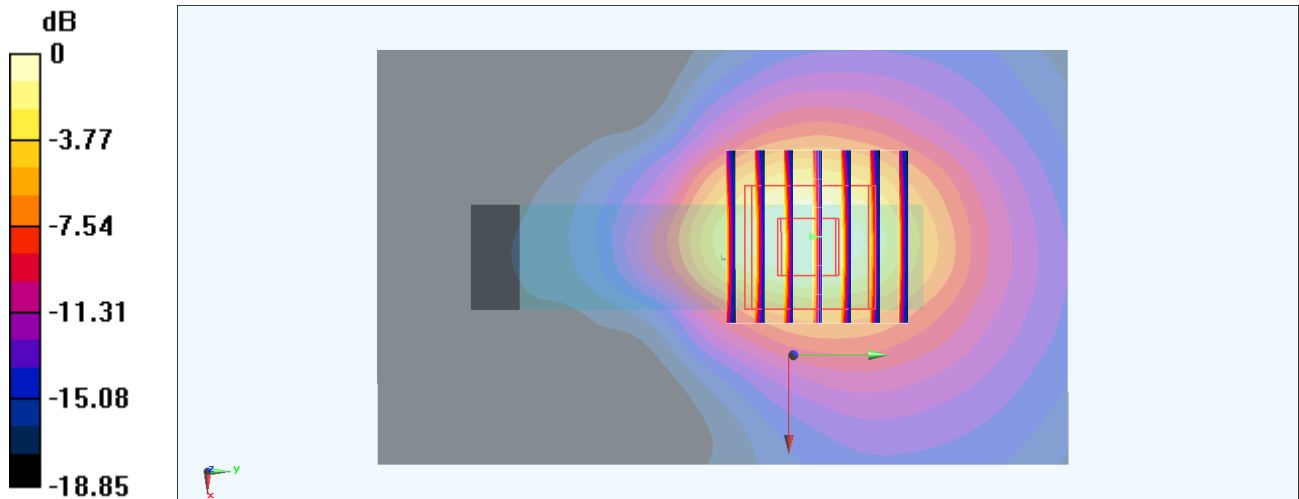

0 dB = 1.26 W/kg = 1.00 dBW/kg

#15_LTE Band 48_20M_QPSK_1_0_Front_10mm_Ch56640

Communication System: LTE; Frequency: 3690 MHz; Duty Cycle: 1:1.59

Medium: HSL_3700_200906 Medium parameters used : $f = 3690$ MHz; $\sigma = 3.158$ S/m; $\epsilon_r = 38.569$; $\rho = 1000$ kg/m³

Ambient Temperature : 23.3 °C ; Liquid Temperature : 22.3 °C

DASY5 Configuration:

- Probe: EX3DV4 - SN3642; ConvF(6.45, 6.45, 6.45) @ 3690 MHz; Calibrated: 2020/4/29
- Sensor-Surface: 1.4mm (Mechanical Surface Detection)
- Electronics: DAE4 Sn376; Calibrated: 2019/12/6
- Phantom: SAM_Right; Type: SAM; Serial: TP:1681
- Measurement SW: DASY52, Version 52.10 (4); SEMCAD X Version 14.6.14 (7483)

Area Scan (91x101x1): Interpolated grid: dx=1.200 mm, dy=1.200 mm

Maximum value of SAR (interpolated) = 0.904 W/kg

Zoom Scan (7x7x8)/Cube 0: Measurement grid: dx=5mm, dy=5mm, dz=1.4mm

Reference Value = 21.44 V/m; Power Drift = -0.06 dB

Peak SAR (extrapolated) = 1.66 W/kg

SAR(1 g) = 0.632 W/kg; SAR(10 g) = 0.280 W/kg

Maximum value of SAR (measured) = 1.18 W/kg

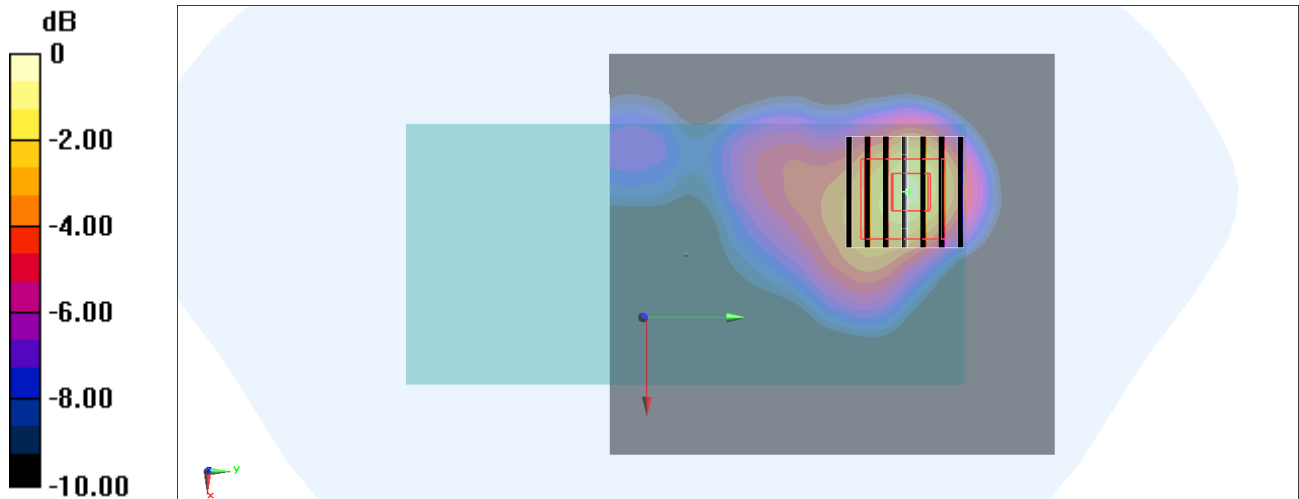

0 dB = 1.18 W/kg = 0.72 dBW/kg

#16_FR1_n25_20M_BPSK_1_53_Top Side_10mm_Ch372000

Communication System: NR; Frequency: 1860 MHz; Duty Cycle: 1:1

Medium: HSL_1900_200905 Medium parameters used: $f = 1860$ MHz; $\sigma = 1.387$ S/m; $\epsilon_r = 39.725$; $\rho = 1000$ kg/m³

Ambient Temperature : 23.5 °C ; Liquid Temperature : 22.5 °C

DASY5 Configuration:

- Probe: ES3DV3 - SN3184; ConvF(5.23, 5.23, 5.23) @ 1860 MHz; Calibrated: 2019/9/25
- Sensor-Surface: 3mm (Mechanical Surface Detection)
- Electronics: DAE4 Sn916; Calibrated: 2019/12/17
- Phantom: SAM_Left; Type: QD000P40CD; Serial: TP:1684
- Measurement SW: DASY52, Version 52.10 (4); SEMCAD X Version 14.6.14 (7483)

Area Scan (51x61x1): Interpolated grid: dx=1.500 mm, dy=1.500 mm

Maximum value of SAR (interpolated) = 0.974 W/kg

Zoom Scan (5x5x7)/Cube 0: Measurement grid: dx=8mm, dy=8mm, dz=5mm

Reference Value = 23.35 V/m; Power Drift = 0.02 dB

Peak SAR (extrapolated) = 1.14 W/kg

SAR(1 g) = 0.732 W/kg; SAR(10 g) = 0.402 W/kg

Maximum value of SAR (measured) = 0.916 W/kg

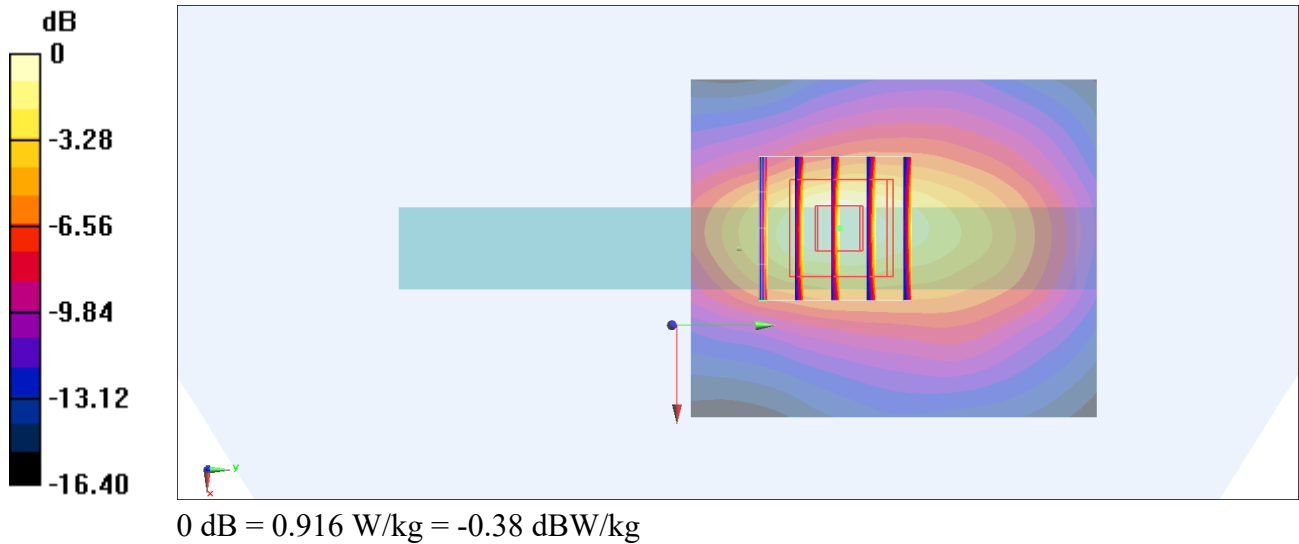

#17_FR1_n41_100M_BPSK_1_1_Top Side_10mm_Ch518598

Communication System: NR; Frequency: 2592.99 MHz; Duty Cycle: 1:1

Medium: HSL_2600_200912 Medium parameters used: $f = 2592.99$ MHz; $\sigma = 1.98$ S/m; $\epsilon_r = 38.761$; $\rho = 1000$ kg/m³

Ambient Temperature : 23.2 °C; Liquid Temperature : 22.2 °C

DASY5 Configuration:

- Probe: EX3DV4 - SN3642; ConvF(6.95, 6.95, 6.95) @ 2592.99 MHz; Calibrated: 2020/4/29
- Sensor-Surface: 1.4mm (Mechanical Surface Detection)
- Electronics: DAE4 Sn376; Calibrated: 2019/12/6
- Phantom: SAM_Left; Type: QD000P40CD; Serial: TP:1682
- Measurement SW: DASY52, Version 52.10 (4); SEMCAD X Version 14.6.14 (7483)

Area Scan (61x151x1): Interpolated grid: dx=1.200 mm, dy=1.200 mm

Maximum value of SAR (interpolated) = 1.15 W/kg

Zoom Scan (7x7x7)/Cube 0: Measurement grid: dx=5mm, dy=5mm, dz=5mm

Reference Value = 13.02 V/m; Power Drift = -0.08 dB

Peak SAR (extrapolated) = 1.45 W/kg

SAR(1 g) = 0.728 W/kg; SAR(10 g) = 0.339 W/kg

Maximum value of SAR (measured) = 1.14 W/kg

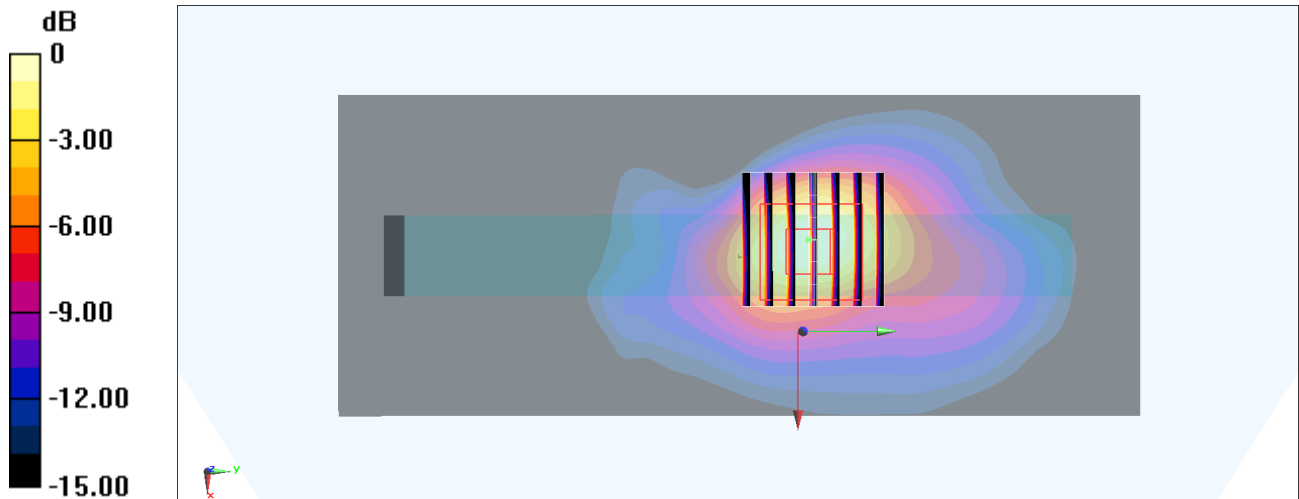

0 dB = 1.14 W/kg = 0.57 dBW/kg

#18_FR1_n66_20M_BPSK_1_53_Back_10mm_Ch354000

Communication System: NR; Frequency: 1770 MHz; Duty Cycle: 1:1

Medium: HSL_1750_200904 Medium parameters used: $f = 1770$ MHz; $\sigma = 1.378$ S/m; $\epsilon_r = 39.337$; $\rho = 1000$ kg/m³

Ambient Temperature : 23.6 °C ; Liquid Temperature : 22.6 °C

DASY5 Configuration:

- Probe: ES3DV3 - SN3270; ConvF(5.41, 5.41, 5.41) @ 1770 MHz; Calibrated: 2019/9/25
- Sensor-Surface: 3mm (Mechanical Surface Detection)
- Electronics: DAE4 Sn1399; Calibrated: 2019/11/14
- Phantom: SAM-Middle; Type: SAM; Serial: TP-1503
- Measurement SW: DASY52, Version 52.10 (4); SEMCAD X Version 14.6.14 (7483)

Area Scan (71x71x1): Interpolated grid: dx=1.500 mm, dy=1.500 mm

Maximum value of SAR (interpolated) = 0.988 W/kg

Zoom Scan (5x5x7)/Cube 0: Measurement grid: dx=8mm, dy=8mm, dz=5mm

Reference Value = 22.24 V/m; Power Drift = 0.01 dB

Peak SAR (extrapolated) = 1.26 W/kg

SAR(1 g) = 0.828 W/kg; SAR(10 g) = 0.518 W/kg

Maximum value of SAR (measured) = 0.970 W/kg

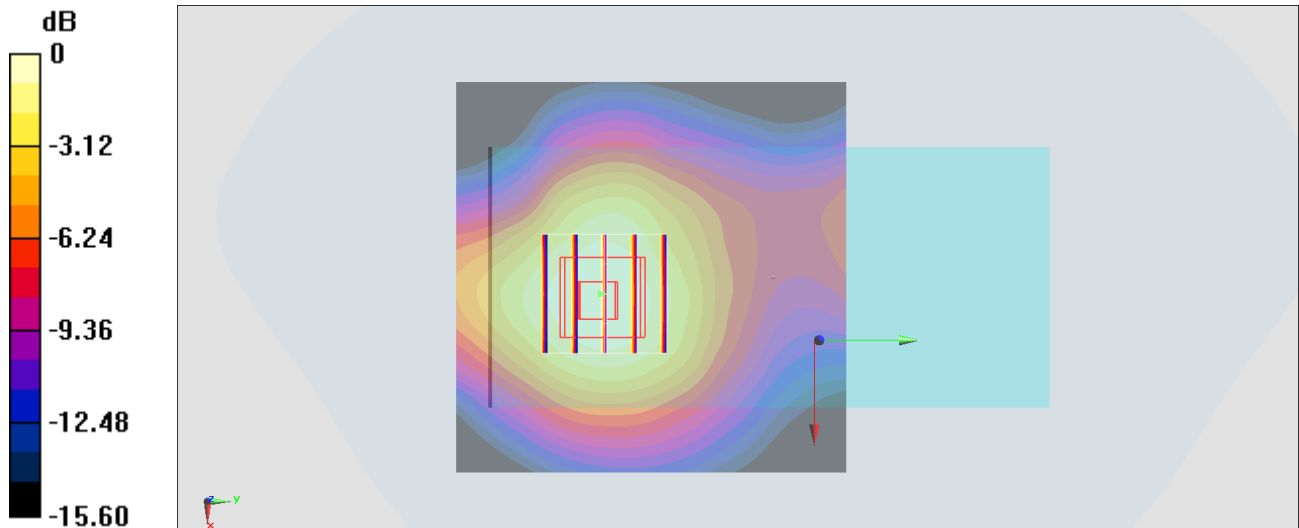

0 dB = 0.970 W/kg = -0.13 dBW/kg

#19_FR1_n71_20M_BPSK_1_1_Front_10mm_Ch136100

Communication System: NR; Frequency: 680.5 MHz; Duty Cycle: 1:1

Medium: HSL_750_200812 Medium parameters used : $f = 680.5$ MHz; $\sigma = 0.882$ S/m; $\epsilon_r = 43.555$; $\rho = 1000$ kg/m³

Ambient Temperature : 23.5 °C ; Liquid Temperature : 22.5 °C

DASY5 Configuration:

- Probe: EX3DV4 - SN3642; ConvF(8.9, 8.9, 8.9) @ 680.5 MHz; Calibrated: 2020/4/29
- Sensor-Surface: 1.4mm (Mechanical Surface Detection)
- Electronics: DAE4 Sn376; Calibrated: 2019/12/6
- Phantom: SAM_Left; Type: QD000P40CD; Serial: TP:1682
- Measurement SW: DASY52, Version 52.10 (4); SEMCAD X Version 14.6.14 (7483)

Area Scan (61x121x1): Interpolated grid: dx=1.500 mm, dy=1.500 mm

Maximum value of SAR (interpolated) = 0.955 W/kg

Zoom Scan (5x5x7)/Cube 0: Measurement grid: dx=8mm, dy=8mm, dz=5mm

Reference Value = 32.27 V/m; Power Drift = -0.12 dB

Peak SAR (extrapolated) = 0.965 W/kg

SAR(1 g) = 0.722 W/kg; SAR(10 g) = 0.539 W/kg

Maximum value of SAR (measured) = 0.881 W/kg

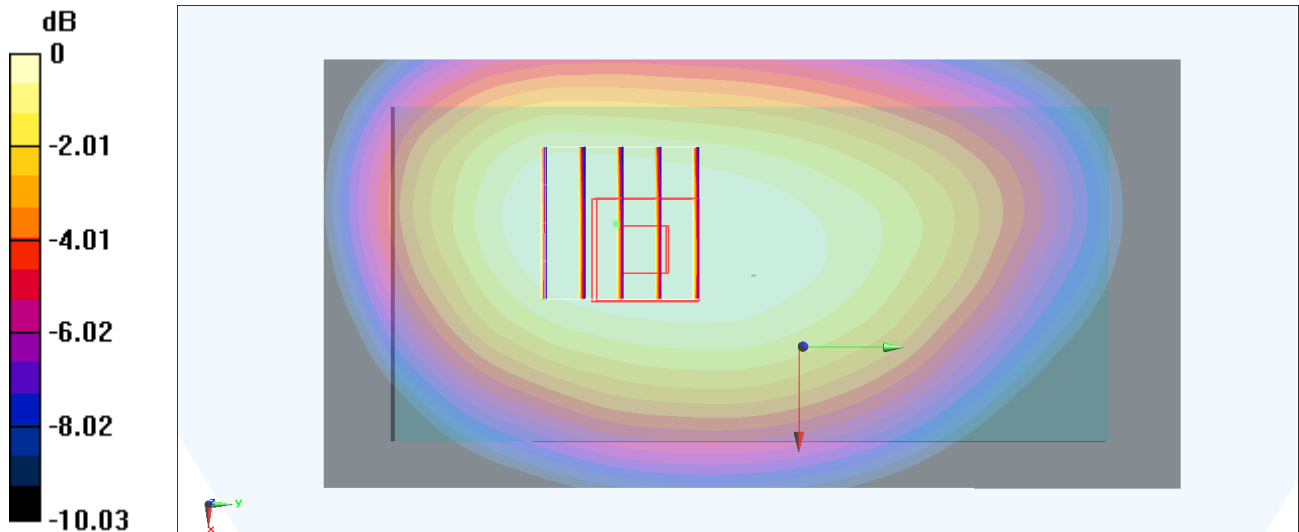

0 dB = 0.881 W/kg = -0.55 dBW/kg