



FCC RADIO TEST REPORT

FCC ID : PKRISGM2000A
Equipment : Wireless Hotspot Modem
Brand Name : Inseego
Model Name : M2000A
Marketing Name : M2000
Applicant : Inseego Corporation
9710 Scranton Road Suite 200, San Diego, CA 92121
Manufacturer : Inseego Corporation
9710 Scranton Road Suite 200, San Diego, CA 92121
Standard : FCC Part 15 Subpart E §15.407

The product was received on Jul. 09, 2020 and testing was started from Jul. 23, 2020 and completed on Sep. 08, 2020. We, SPORTON INTERNATIONAL INC., EMC & Wireless Communications Laboratory, would like to declare that the tested sample has been evaluated in accordance with the test procedures and has been in compliance with the applicable technical standards.

The test results in this report apply exclusively to the tested model / sample. Without written approval of SPORTON INTERNATIONAL INC. EMC & Wireless Communications Laboratory, the test report shall not be reproduced except in full.

Louis Wu

Approved by: Louis Wu

SPORTON INTERNATIONAL INC. EMC & Wireless Communications Laboratory
No. 52, Huaya 1st Rd., Guishan Dist., Taoyuan City, Taiwan (R.O.C.)



Table of Contents

History of this test report..... 3

Summary of Test Result..... 4

1 General Description 5

 1.1 Product Feature of Equipment Under Test..... 5

 1.2 Modification of EUT 5

 1.3 Testing Location 6

 1.4 Applicable Standards..... 6

2 Test Configuration of Equipment Under Test 7

 2.1 Carrier Frequency and Channel 7

 2.2 Test Mode 8

 2.3 Connection Diagram of Test System 9

 2.4 Support Unit used in test configuration and system 10

 2.5 EUT Operation Test Setup 10

 2.6 Measurement Results Explanation Example..... 10

3 Test Result 11

 3.1 6dB and 26dB and 99% Occupied Bandwidth Measurement 11

 3.2 Maximum Conducted Output Power Measurement 15

 3.3 Power Spectral Density Measurement 16

 3.4 Unwanted Emissions Measurement 20

 3.5 AC Conducted Emission Measurement..... 25

 3.6 Automatically Discontinue Transmission 27

 3.7 Antenna Requirements 28

4 List of Measuring Equipment..... 29

5 Uncertainty of Evaluation 31

Appendix A. Conducted Test Results

Appendix B. AC Conducted Emission Test Result

Appendix C. Radiated Spurious Emission

Appendix D. Radiated Spurious Emission Plots

Appendix E. Duty Cycle Plots

Appendix F. Setup Photographs



History of this test report

Report No.	Version	Description	Issued Date
FR041657C	01	Initial issue of report	Sep. 16, 2020



Summary of Test Result

Report Clause	Ref Std. Clause	Test Items	Result (PASS/FAIL)	Remark
3.1	15.403 (i)	6dB & 26dB Bandwidth	Pass	-
3.1	2.1049	99% Occupied Bandwidth	Reporting only	-
3.2	15.407 (a)	Maximum Conducted Output Power	Pass	-
3.3	15.407 (a)	Power Spectral Density	Pass	-
3.4	15.407(b)	Unwanted Emissions	Pass	Under limit 10.05 dB at 889.420 MHz
3.5	15.207	AC Conducted Emission	Pass	Under limit 17.34 dB at 0.150 MHz
3.6	15.407 (c)	Automatically Discontinue Transmission	Pass	-
3.7	15.203 & 15.407 (a)	Antenna Requirement	Pass	-

Declaration of Conformity:

The test results with all measurement uncertainty excluded are presented in accordance with the regulation limits or requirements declared by manufacturers.

Comments and Explanations:

The declared of product specification for EUT presented in the report are provided by the manufacturer, and the manufacturer takes all the responsibilities for the accuracy of product specification.

Reviewed by: Wii Chang

Report Producer: Tina Chuang



1 General Description

1.1 Product Feature of Equipment Under Test

WCDMA/LTE/5G NR, Wi-Fi 2.4GHz 802.11b/g/n/ax, Wi-Fi 5GHz 802.11a/n/ac/ax and GNSS.

Product Specification subjective to this standard	
Antenna Type	WWAN: Fixed Internal Antenna WLAN <Ant. 0>: Fixed Internal Antenna <Ant. 1>: Fixed Internal Antenna GPS: Fixed Internal Antenna

1.2 Modification of EUT

No modifications are made to the EUT during all test items.



1.3 Testing Location

Test Site	SPORTON INTERNATIONAL INC. EMC & Wireless Communications Laboratory	
Test Site Location	No.52, Huaya 1st Rd., Guishan Dist., Taoyuan City, Taiwan (R.O.C.) TEL: +886-3-327-3456 FAX: +886-3-328-4978	
Test Site No.	Sporton Site No.	
	TH05-HY	CO05-HY

Note: The test site complies with ANSI C63.4 2014 requirement.

Test Site	SPORTON INTERNATIONAL INC. EMC & Wireless Communications Laboratory	
Test Site Location	No.58, Aly. 75, Ln. 564, Wenhua 3rd, Rd., Guishan Dist., Taoyuan City, Taiwan (R.O.C.) TEL: +886-3-327-0868 FAX: +886-3-327-0855	
Test Site No.	Sporton Site No.	
	03CH15-HY	

Note: The test site complies with ANSI C63.4 2014 requirement.

FCC designation No.: TW1190 and TW0007

1.4 Applicable Standards

According to the specifications of the manufacturer, the EUT must comply with the requirements of the following standards:

- ♦ FCC Part 15 Subpart E
- ♦ FCC KDB 789033 D02 General UNII Test Procedures New Rules v02r01.
- ♦ FCC KDB 414788 D01 Radiated Test Site v01r01.
- ♦ FCC KDB 662911 D01 Multiple Transmitter Output v02r01.
- ♦ ANSI C63.10-2013

Remark:

1. All test items were verified and recorded according to the standards and without any deviation during the test.
2. The TAF code is not including all the FCC KDB listed without accreditation.
3. This EUT has also been tested and complied with the requirements of FCC Part 15, Subpart B, recorded in a separate test report.



2 Test Configuration of Equipment Under Test

- a. The EUT has been associated with peripherals and configuration operated in a manner tended to maximize its emission characteristics in a typical application. Frequency range investigated: conduction emission (150 kHz to 30 MHz), radiation emission (9 kHz to the 10th harmonic of the highest fundamental frequency or to 40 GHz, whichever is lower). For radiated measurement, pre-scanned in three orthogonal panels, X, Y, Z. The worst cases (X plane) were recorded in this report.
- b. AC power line Conducted Emission was tested under maximum output power.

2.1 Carrier Frequency and Channel

Frequency Band	Channel	Freq. (MHz)	Channel	Freq. (MHz)
5725-5850 MHz Band 4 (U-NII-3)	149	5745	157	5785
	151*	5755	159*	5795
	153	5765	161	5805
	155#	5775	165	5825

Note:

1. The above Frequency and Channel in "*" were 802.11n HT40 and 802.11ac VHT40.
2. The above Frequency and Channel in "#n" were 802.11ac VHT80.



2.2 Test Mode

Final test modes are considering the modulation and worse data rates as below table.

The CDD mode is chosen as worst case configuration for all test cases due to higher power than SISO mode.

The 802.11ax mode is investigated among different tones, full resource units (RU), partial resource units. The partial RU has no higher power and PSD than full RU's, thus the full RU is chosen as main test configuration, and the partial RU is verified the band edge in accordance with the TCB workshop, Oct. 3rd .2018.

Modulation	Data Rate
802.11a	6 Mbps
802.11n HT20 (Covered by HE20)	MCS0
802.11n HT40 (Covered by HE40)	MCS0
802.11ac VHT20 (Covered by HE20)	MCS0
802.11ac VHT40 (Covered by HE40)	MCS0
802.11ac VHT80 (Covered by HE80)	MCS0
802.11ax HE20	MCS0
802.11ax HE40	MCS0
802.11ax HE80	MCS0

Test Cases	
AC Conducted Emission	Mode 1 : WCDMA Band V Idle + WLAN (5GHz) Link + Battery 1 + AC Adapter
Remark: For Radiated Test Cases, the tests were performed with Battery 2.	

Ch. #	Band IV : 5725-5850 MHz			
	802.11a	802.11ax HE20	802.11ax HE40	802.11ax HE80
L Low	149	149	151	-
M Middle	157	157	-	155
H High	165	165	159	-

Remark: For radiation spurious emission, the final modulation and the worst data rate was reference the max RF conducted power, the worst mode of WLAN and LTE for simultaneous transmission were verified and compliant.

2.3 Connection Diagram of Test System

<AC Conducted Emission Mode>

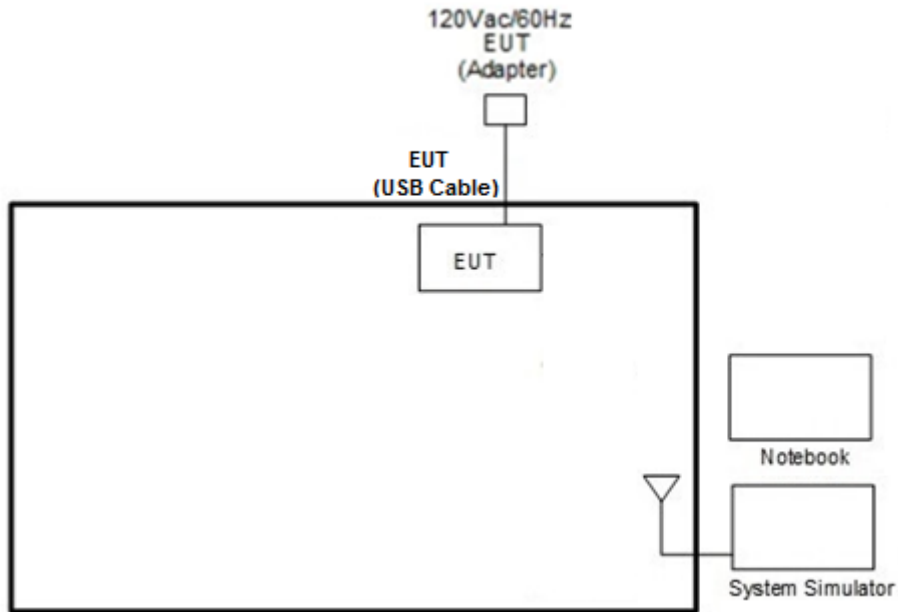

<WLAN Tx Mode>

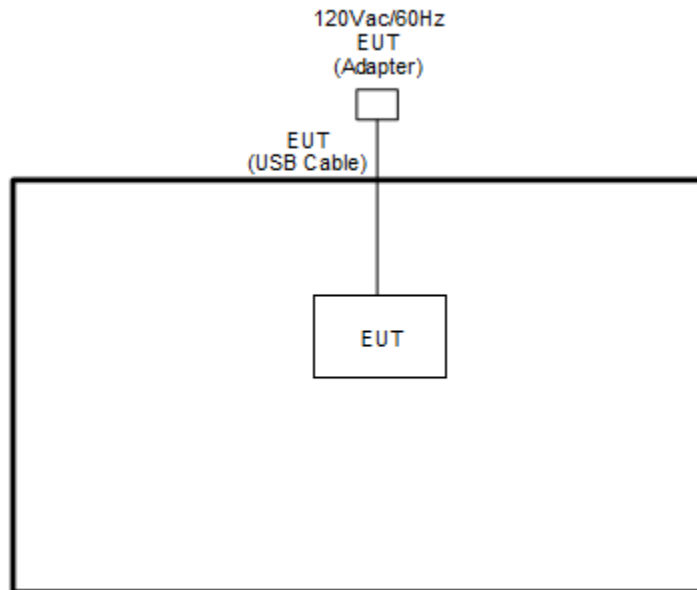



2.4 Support Unit used in test configuration and system

Item	Equipment	Brand Name	Model Name	FCC ID	Data Cable	Power Cord
1.	System Simulator	Anritsu	MT8820C	N/A	N/A	Unshielded, 1.8 m
2.	Notebook	Dell	Latitude 3400	FCC DoC	N/A	AC I/P: Unshielded, 1.2 m DC O/P: Shielded, 1.8 m

2.5 EUT Operation Test Setup

The RF test items, utility “QRCT V4.0.00156.0” was installed in Notebook which was programmed in order to make the EUT get into the engineering modes to provide channel selection, power level, data rate and the application type and for continuous transmitting signals.

2.6 Measurement Results Explanation Example

For all conducted test items:

The offset level is set in the spectrum analyzer to compensate the RF cable loss and attenuator factor between EUT conducted output port and spectrum analyzer. With the offset compensation, the spectrum analyzer reading level is exactly the EUT RF output level.

Example :

The spectrum analyzer offset is derived from RF cable loss and attenuator factor.

Offset = RF cable loss + attenuator factor.

Following shows an offset computation example with cable loss 4.2 dB and 10dB attenuator.

$$\begin{aligned} \text{Offset(dB)} &= \text{RF cable loss(dB)} + \text{attenuator factor(dB)}. \\ &= 4.2 + 10 = 14.2 \text{ (dB)} \end{aligned}$$

3 Test Result

3.1 6dB and 26dB and 99% Occupied Bandwidth Measurement

3.1.1 Description of 6dB and 26dB and 99% Occupied Bandwidth

The minimum 6 dB bandwidth shall be at least 500 kHz.

26dB and 99% Occupied bandwidth are reporting only.

3.1.2 Measuring Instruments

See list of measuring equipment of this test report.

3.1.3 Test Procedures

1. The testing follows FCC KDB 789033 D02 General UNII Test Procedures New Rules v02r01. Section C) Emission bandwidth for the band 5.725-5.85GHz
2. Set RBW = 100kHz.
3. Set the VBW $\geq 3 \times$ RBW.
4. Detector = Peak.
5. Trace mode = max hold
6. Measure the maximum width of the emission that is 6 dB down from the peak of the emission.
7. Measure and record the results in the test report.

3.1.4 Test Setup

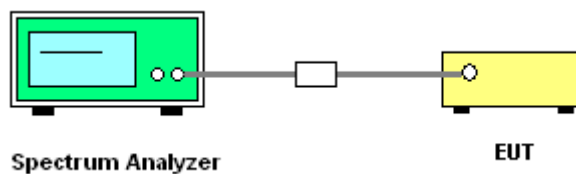

3.1.5 Test Result of 6dB and 26dB and 99% Occupied Bandwidth

Please refer to Appendix A.

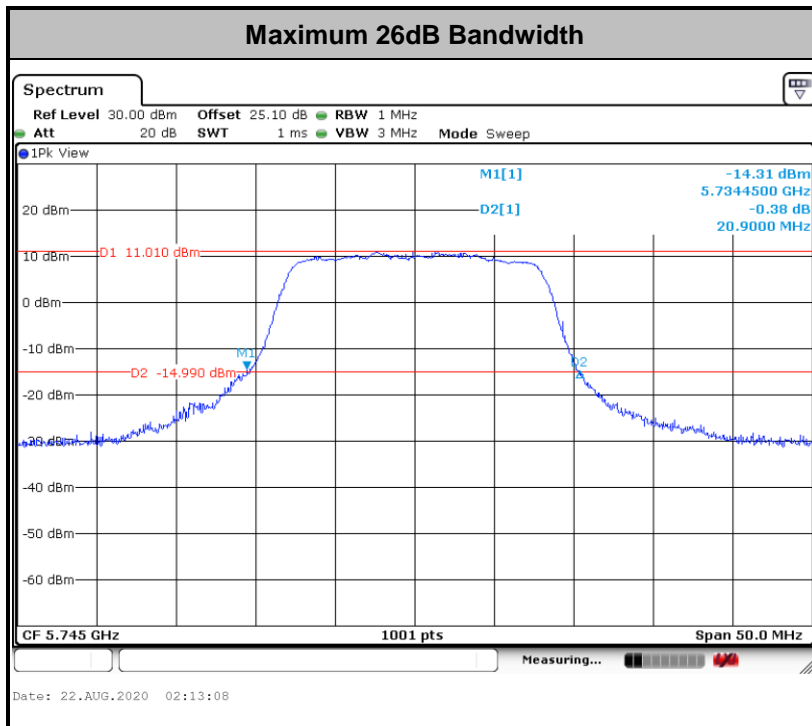
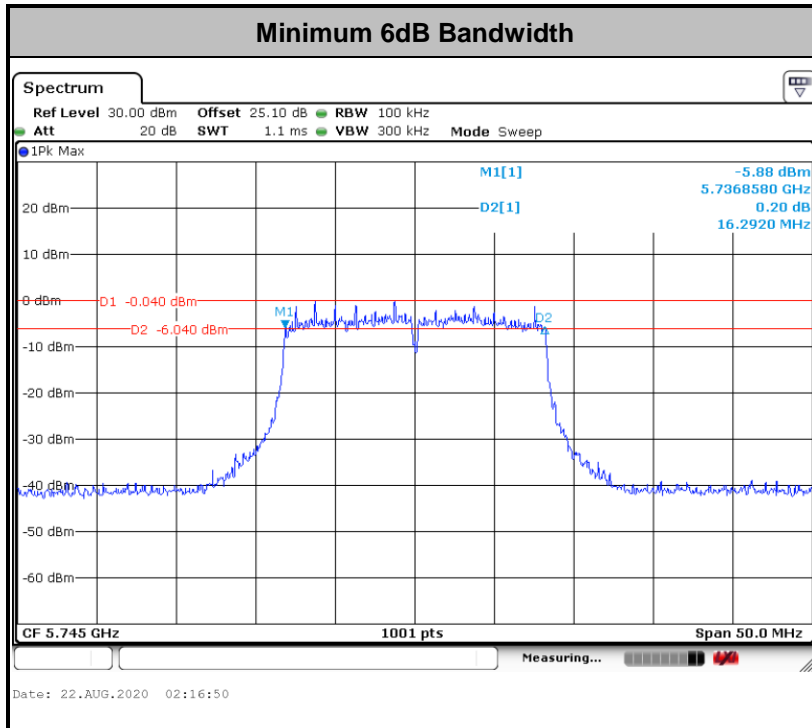

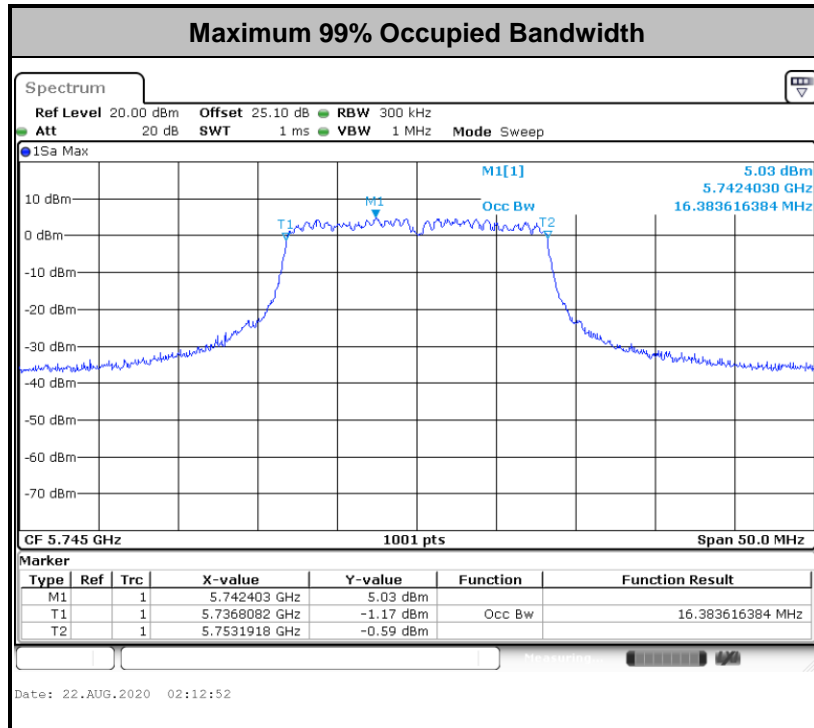

Note: The occupied channel bandwidth is maintained within the band of operation for all of the modulations.

<For 802.11ax Mode>

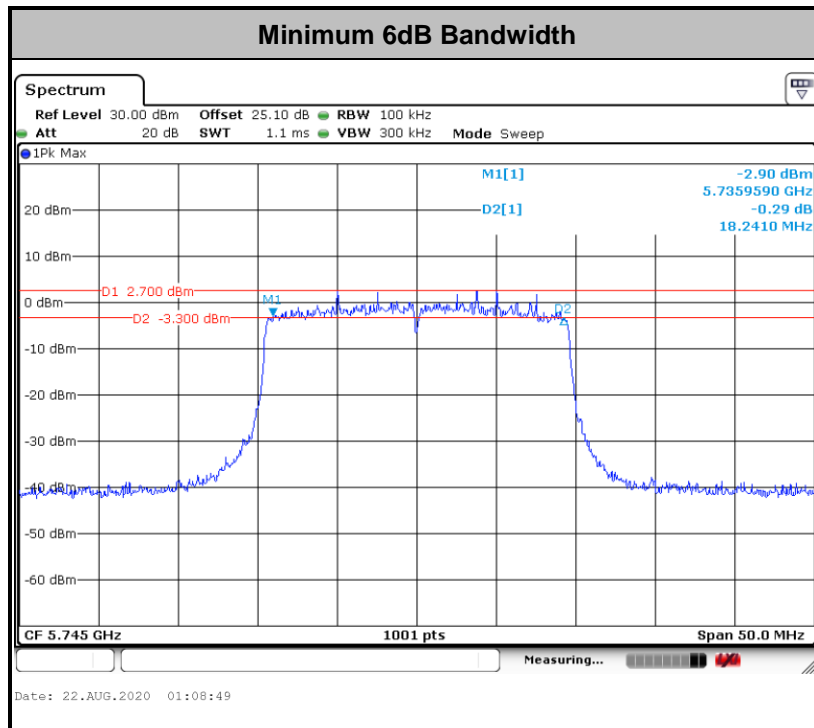

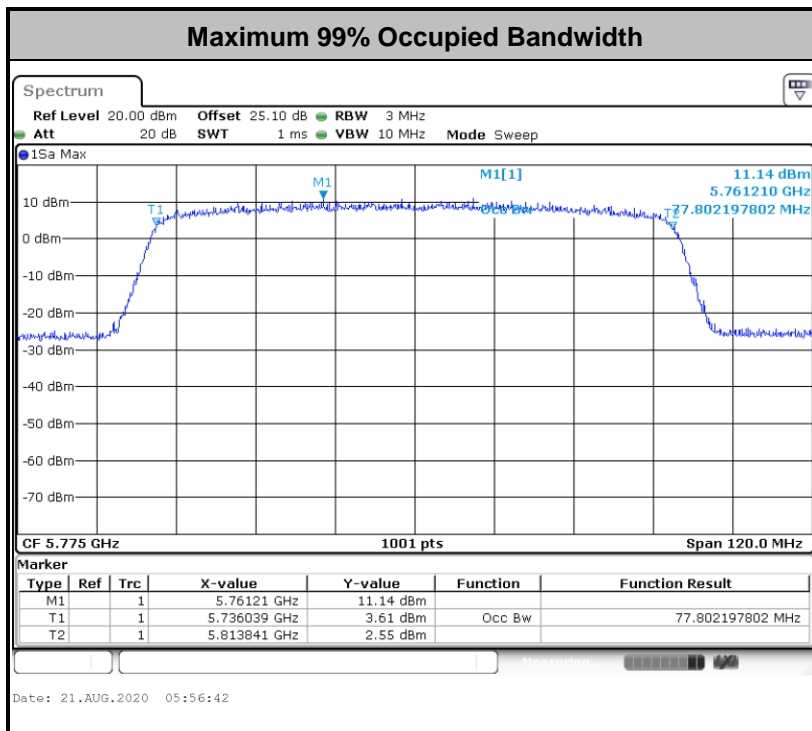
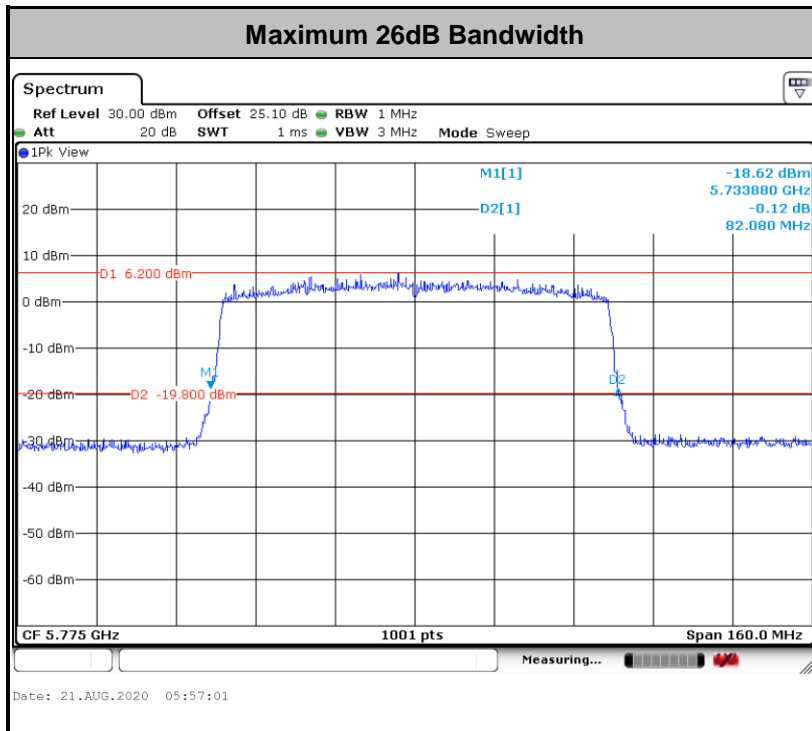

Note: The occupied channel bandwidth is maintained within the band of operation for all of the modulations.

3.2 Maximum Conducted Output Power Measurement

3.2.1 Limit of Maximum Conducted Output Power

For the band 5.725–5.85 GHz, the maximum conducted output power over the frequency band of operation shall not exceed 1 W.

If transmitting antennas of directional gain greater than 6 dBi are used, the peak output power shall be reduced by the amount in dB that the directional gain of the antenna exceeds 6 dBi.

3.2.2 Measuring Instruments

See list of measuring equipment of this test report.

3.2.3 Test Procedures

<CDD Modes>

The testing follows Method PM-G of FCC KDB 789033 D02 General UNII Test Procedures New Rules v02r01 for TXBF modes.

Method PM-G (Measurement using a gated RF average power meter):

1. Measurement is performed using a wideband RF power meter.
2. The EUT is configured to transmit at its maximum power control level.
3. Measure the average power of the transmitter
4. Since the measurement is made only during the ON time of the transmitter, no duty cycle correction factor is required.

3.2.4 Test Setup

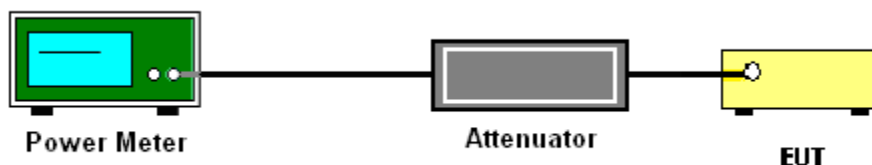

3.2.5 Test Result of Maximum Conducted Output Power

Please refer to Appendix A.



3.3 Power Spectral Density Measurement

3.3.1 Limit of Power Spectral Density

For the band 5.725–5.85 GHz, the maximum power spectral density shall not exceed 30 dBm in any 500-kHz band.

If transmitting antennas of directional gain greater than 6 dBi are used, the peak output power shall be reduced by the amount in dB that the directional gain of the antenna exceeds 6 dBi.

3.3.2 Measuring Instruments

See list of measuring equipment of this test report.

3.3.3 Test Procedures

The testing follows FCC KDB 789033 D02 General UNII Test Procedures New Rules v02r01. Section F) Maximum power spectral density.

Method SA-3

(power averaging (rms) detection with max hold):

- Set span to encompass the entire emission bandwidth (EBW) of the signal.
- Set RBW = 300 kHz.
- Set VBW \geq 1 MHz.
- Number of points in sweep \geq 2 Span / RBW.
- Sweep time \leq (number of points in sweep) \times T, when duty cycle is less than 98 percent where T is the minimum transmission duration over which the transmitter is on and is transmitting at its maximum power control level for the tested mode of operation.
- Detector = power averaging (rms).
- Trace mode = max hold.
- Allow max hold to run for at least 60 seconds, or longer as needed to allow the trace to stabilize.

1. The RF output of EUT was connected to the spectrum analyzer by a low loss cable.
2. Each plot has already offset with cable loss, and attenuator loss. Measure the PPSD and record it.
3. For MIMO mode, calculation method follows FCC KDB 662911 D01 Multiple Transmitter Output v02r01.

Method (c): Measure and add $10 \log(N_{ANT})$ dB.

With this technique, spectrum measurements are performed at each output of the device, but rather than summing the spectra or the spectral peaks across the outputs, the quantity $10 \log(N_{ANT})$ dB is added to each spectrum value before comparing to the emission limit. The addition of $10 \log(N_{ANT})$ dB serves to apportion the emission limit among the N_{ANT} outputs so that each output is permitted to contribute no more than $1/N_{ANT}^{\text{th}}$ of the PSD limit.

3.3.4 Test Setup

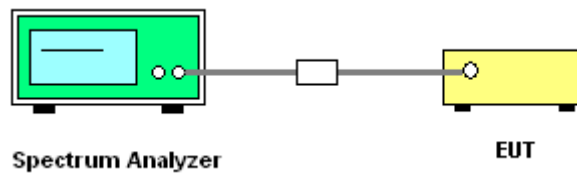



3.3.5 Test Result of Power Spectral Density

Please refer to Appendix A.

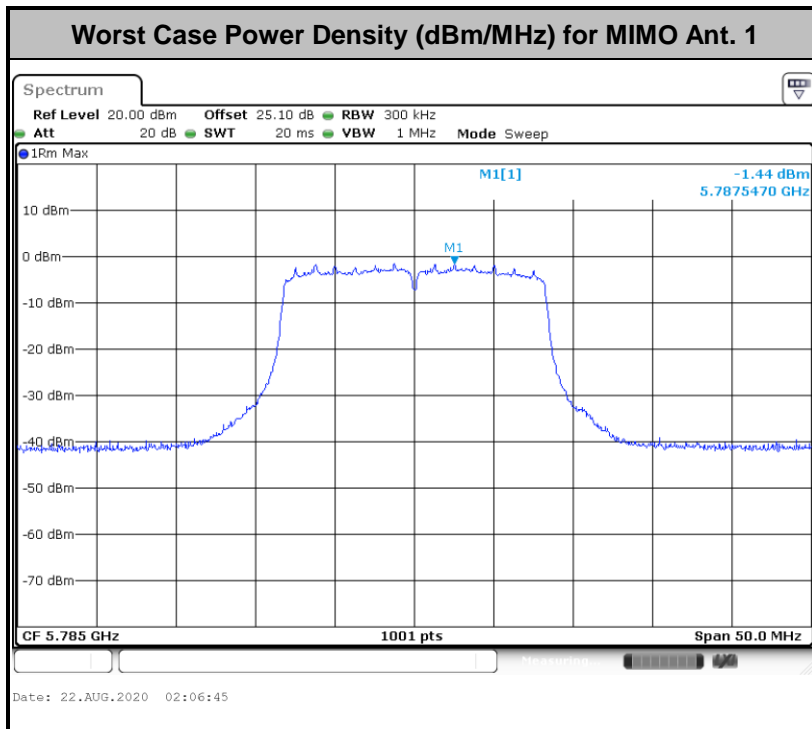
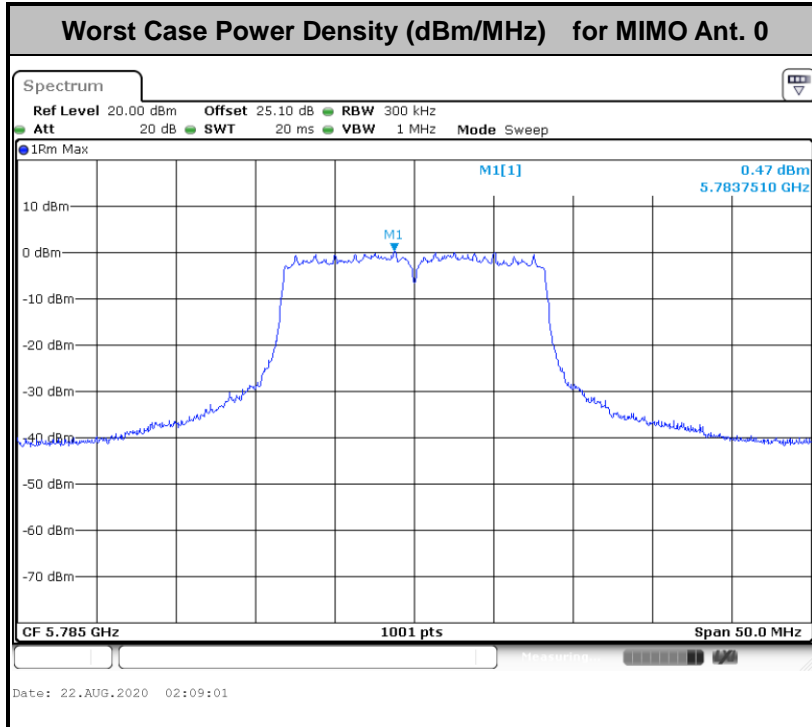



<For 802.11ax Mode>

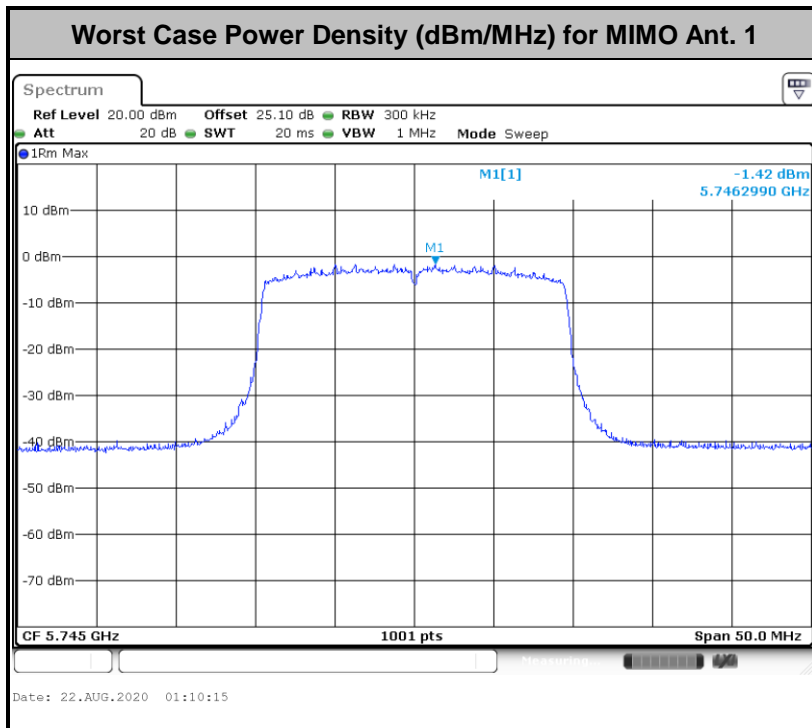
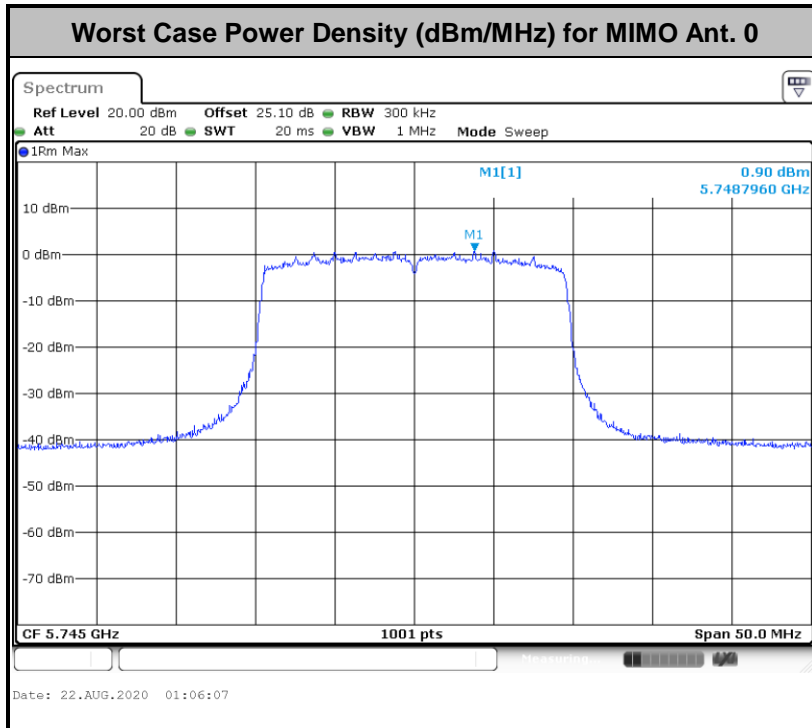



3.4 Unwanted Emissions Measurement

This section is to measure unwanted emissions through radiated measurement for band edge spurious emissions and out of band emissions measurement.

3.4.1 Limit of Unwanted Emissions

(1) For transmitters operating in the 5.725-5.85 GHz band:

15.407(b)(4)(i) All emissions shall be limited to a level of -27 dBm/MHz at 75 MHz or more above or below the band edge increasing linearly to 10 dBm/MHz at 25 MHz above or below the band edge, and from 25 MHz above or below the band edge increasing linearly to a level of 15.6 dBm/MHz at 5 MHz above or below the band edge, and from 5 MHz above or below the band edge increasing linearly to a level of 27 dBm/MHz at the band edge.

(2) Unwanted spurious emissions fallen in restricted bands shall comply with the general field strength limits as below table,

Frequency (MHz)	Field Strength (microvolts/meter)	Measurement Distance (meters)
0.009 – 0.490	2400/F(kHz)	300
0.490 – 1.705	24000/F(kHz)	30
1.705 – 30.0	30	30
30 – 88	100	3
88 – 216	150	3
216 - 960	200	3
Above 960	500	3

Note: The following formula is used to convert the EIRP to field strength.

$$E = \frac{1000000\sqrt{30P}}{3} \text{ } \mu\text{V/m, where P is the eirp (Watts)}$$



EIRP (dBm)	Field Strength at 3m (dBμV/m)
- 27	68.3

(3) KDB789033 D02 v02r01 G)2)c)

- (i) Sections 15.407(b)(1-3) specifies the unwanted emissions limit for the U-NII-1 and U-NII-2 bands. As specified, emissions above 1000 MHz that are outside of the restricted bands are subject to a peak emission limit of -27 dBm/MHz.
- (ii) Section 15.407(b)(4) specifies the unwanted emissions limit for the U-NII-3 band. A band emissions mask is specified in Section 15.407(b)(4)(i). The emission limits are based on the use of a peak detector.

3.4.2 Measuring Instruments

See list of measuring equipment of this test report.

3.4.3 Test Procedures

1. The testing follows FCC KDB 789033 D02 General UNII Test Procedures New Rules v02r01. Section G) Unwanted emissions measurement.

(1) Procedure for Unwanted Emissions Measurements Below 1000MHz

- RBW = 120 kHz
- VBW = 300 kHz
- Detector = Peak
- Trace mode = max hold

(2) Procedure for Peak Unwanted Emissions Measurements Above 1000 MHz

- RBW = 1 MHz
- VBW ≥ 3 MHz
- Detector = Peak
- Sweep time = auto
- Trace mode = max hold

(3) Procedures for Average Unwanted Emissions Measurements Above 1000MHz

- RBW = 1 MHz
- VBW = 10 Hz, when duty cycle is no less than 98 percent.
- VBW ≥ 1/T, when duty cycle is less than 98 percent where T is the minimum transmission duration over which the transmitter is on and is transmitting at its maximum power control level for the tested mode of operation.



2. The EUT was placed on a turntable with 0.8 meter for frequency below 1GHz and 1.5 meter for frequency above 1GHz respectively above ground.
3. The EUT was set 3 meters from the interference receiving antenna which was mounted on the top of a variable height antenna tower.
4. The antenna is a broadband antenna and its height is adjusted between one meter and four meters above ground to find the maximum value of the field strength for both horizontal polarization and vertical polarization of the antenna.
5. For each suspected emission, the EUT was arranged to its worst case and then adjust the antenna tower (from 1 m to 4 m) and turntable (from 0 degree to 360 degrees) to find the maximum reading.
6. For testing below 1GHz, if the emission level of the EUT in peak mode was 3 dB lower than the limit specified, then peak values of EUT will be reported, otherwise, the emissions will be repeated one by one using the CISPR quasi-peak method and reported.
7. For testing above 1GHz, the emission level of the EUT in peak mode was 20dB lower than average limit (that means the emission level in average mode also complies with the limit in average mode), then peak values of EUT will be reported, otherwise, the emissions will be measured in average mode again and reported.

3.4.4 Test Setup

For radiated emissions below 30MHz

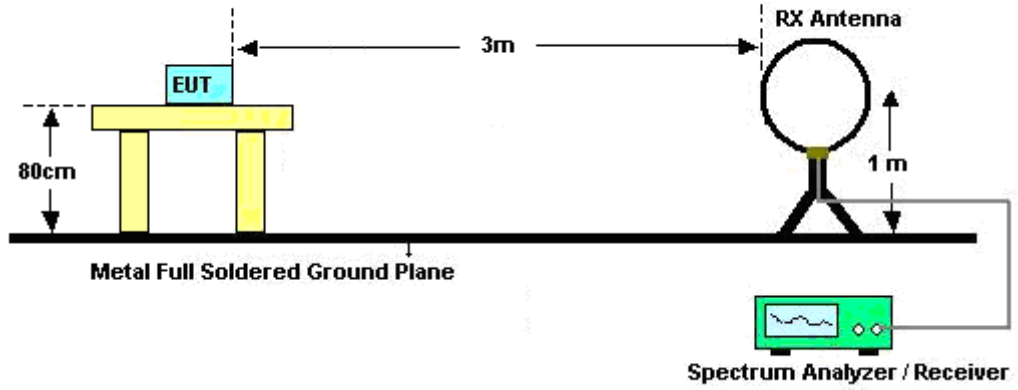

For radiated emissions from 30MHz to 1GHz

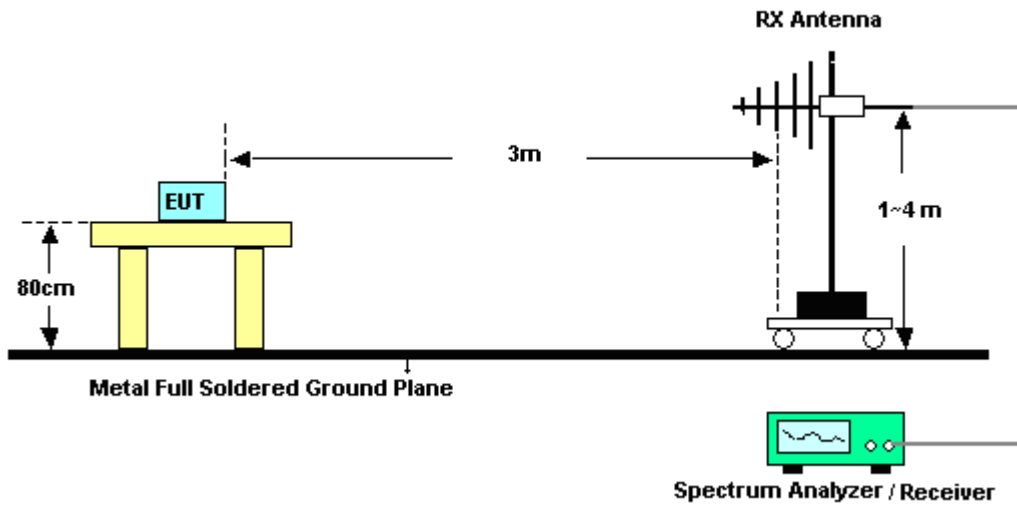

For radiated emissions above 1GHz

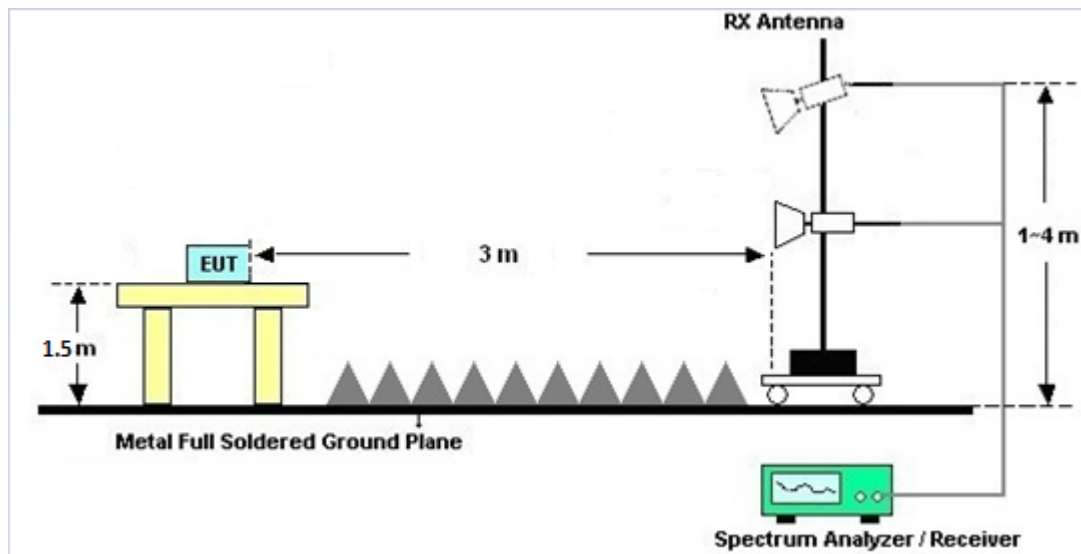

3.4.5 Test Results of Radiated Emissions (9 kHz ~ 30 MHz)

The low frequency, which started from 9 kHz to 30MHz, was pre-scanned and the result which was 20dB lower than the limit line was not reported.

There is a comparison data of both open-field test site and alternative test site - semi-Anechoic chamber according to 414788 D01 Radiated Test Site v01r01, and the result came out very similar.

3.4.6 Test Result of Radiated Band Edges

Please refer to Appendix C and D.

3.4.7 Duty Cycle

Please refer to Appendix E.

3.4.8 Test Result of Unwanted Radiated Emission (30MHz ~ 10th Harmonic)

Please refer to Appendix C and D.



3.5 AC Conducted Emission Measurement

3.5.1 Limit of AC Conducted Emission

For equipment that is designed to be connected to the public utility (AC) power line, the radio frequency voltage that is conducted back onto the AC power line on any frequency or frequencies within the band 150 kHz to 30 MHz shall not exceed the limits in the following table.

Frequency of emission (MHz)	Conducted limit (dB μ V)	
	Quasi-peak	Average
0.15-0.5	66 to 56*	56 to 46*
0.5-5	56	46
5-30	60	50

*Decreases with the logarithm of the frequency.

3.5.2 Measuring Instruments

See list of measuring equipment of this test report.

3.5.3 Test Procedures

1. The EUT was placed 0.4 meter from the conducting wall of the shielding room was kept at least 80 centimeters from any other grounded conducting surface.
2. Connect EUT to the power mains through a line impedance stabilization network (LISN).
3. All the support units are connecting to the other LISN.
4. The LISN provides 50 ohm coupling impedance for the measuring instrument.
5. The FCC states that a 50 ohm, 50 microhenry LISN should be used.
6. Both sides of AC line were checked for maximum conducted interference.
7. The frequency range from 150 kHz to 30 MHz was searched.
8. Set the test-receiver system to Peak Detect Function and specified bandwidth with Maximum Hold Mode.

3.5.4 Test Setup

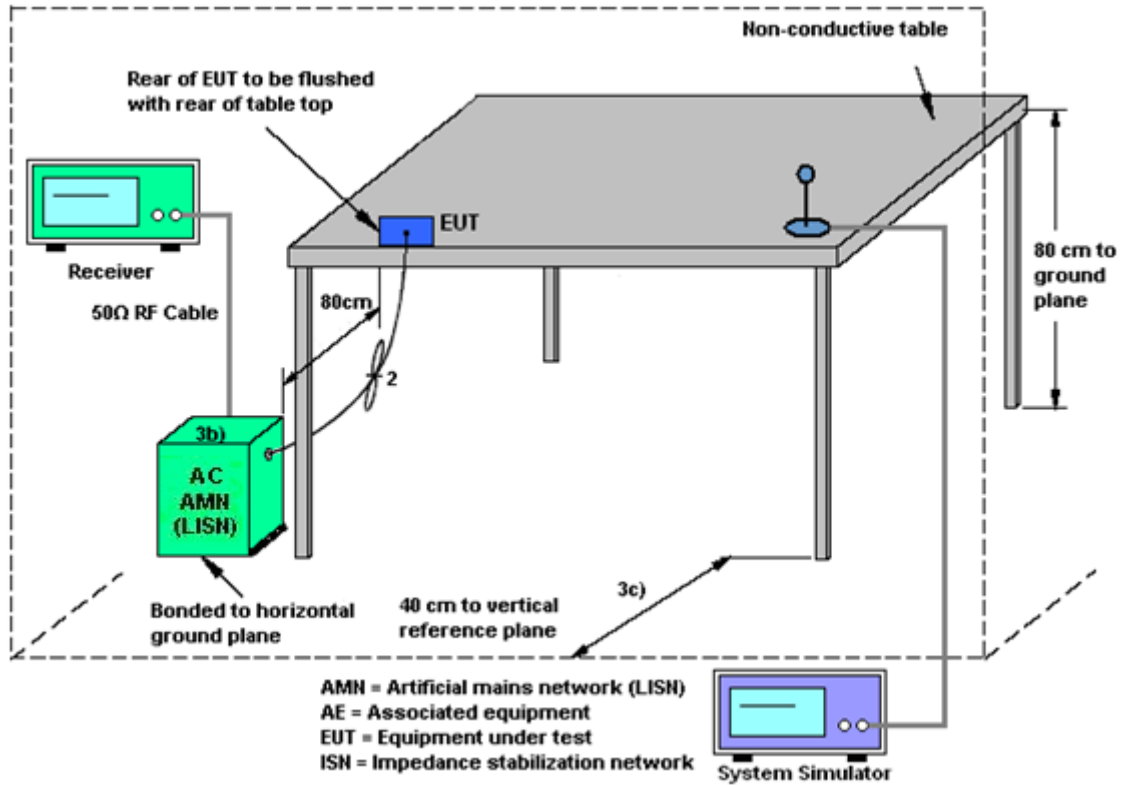

3.5.5 Test Result of AC Conducted Emission

Please refer to Appendix B.



3.6 Automatically Discontinue Transmission

3.6.1 Limit of Automatically Discontinue Transmission

The device shall automatically discontinue transmission in case of either absence of information to transmit or operational failure. These provisions are not intended to preclude the transmission of control or signaling information or the use of repetitive codes used by certain digital technologies to complete frame or burst intervals. Applicants shall include in their application for equipment authorization to describe how this requirement is met.

3.6.2 Measuring Instruments

See list of measuring equipment of this test report.

3.6.3 Test Result of Automatically Discontinue Transmission

While the EUT is not transmitting any information, the EUT can automatically discontinue transmission and become standby mode for power saving. The EUT can detect the controlling signal of ACK message transmitting from remote device and verify whether it shall resend or discontinue transmission.



3.7 Antenna Requirements

3.7.1 Standard Applicable

If transmitting antenna directional gain is greater than 6 dBi, both the peak transmit power and the peak power spectral density shall be reduced by the amount in dB that the directional gain of the antenna exceeds 6 dBi.

3.7.2 Antenna Anti-Replacement Construction

An embedded-in antenna design is used.

3.7.3 Antenna Gain

<CDD Modes >

FCC KDB 662911 D01 Multiple Transmitter Output v02r01

For CDD transmissions, directional gain is calculated as

Directional gain = GANT + Array Gain, where Array Gain is as follows.

For power spectral density (PSD) measurements on all devices,

Array Gain = 10 log(NANT/NSS=1) dB.

For power measurements on IEEE 802.11 devices,

Array Gain = 0 dB (i.e., no array gain) for NANT ≤ 4.

Directional gain may be calculated by using the formulas applicable to equal gain antennas with GANT set equal to the gain of the antenna having the highest gain;

The EUT supports CDD mode.

For power, the directional gain GANT is set equal to the antenna having the highest gain, i.e., F)2)f)i).

For PSD, the directional gain calculation is following F)2)f)ii) of KDB 662911 D01 v02r01.

The power and PSD limit should be modified if the directional gain of EUT is over 6 dBi,

The directional gain "DG" is calculated as following table.

<CDD Modes>						
			DG	DG	Power	PSD
	Ant. 0	Ant. 1	for	for	Limit	Limit
	(dBi)	(dBi)	Power	PSD	Reduction	Reduction
			(dBi)	(dBi)	(dB)	(dB)
Band IV	4.50	2.40	4.50	6.52	0.00	0.52

Power Limit Reduction = DG(Power) – 6dBi, (min = 0)

PSD Limit Reduction = DG(PSD) – 6dBi, (min = 0)



4 List of Measuring Equipment

Instrument	Brand Name	Model No.	Serial No.	Characteristics	Calibration Date	Test Date	Due Date	Remark
Loop Antenna	Rohde & Schwarz	HFH2-Z2	100488	9 kHz~30 MHz	Jan. 09, 2020	Aug. 14, 2020~ Sep. 08, 2020	Jan. 08, 2021	Radiation (03CH15-HY)
Bilog Antenna	TESEQ	CBL6111D&0 0800N1D01N- 06	41912&05	30MHz to 1GHz	Feb. 09, 2020	Aug. 14, 2020~ Sep. 08, 2020	Feb. 08, 2021	Radiation (03CH15-HY)
Amplifier	SONOMA	310N	363440	9kHz~1GHz	Dec. 27, 2019	Aug. 14, 2020~ Sep. 08, 2020	Dec. 26, 2020	Radiation (03CH15-HY)
Horn Antenna	SCHWARZBE CK	BBHA 9120 D	9120D-162 0	1-18GHz	Oct. 28, 2019	Aug. 14, 2020~ Sep. 08, 2020	Oct. 27, 2020	Radiation (03CH15-HY)
SHF-EHF Horn Antenna	SCHWARZBE CK	BBHA 9170	BBHA9170 584	18GHz- 40GHz	Dec. 10, 2019	Aug. 14, 2020~ Sep. 08, 2020	Dec. 09, 2020	Radiation (03CH15-HY)
Preamplifier	Jet-Power	JPA0118-55-3 03	171000180 0055006	1GHz~18GHz	May 07, 2020	Aug. 14, 2020~ Sep. 08, 2020	May 06, 2021	Radiation (03CH15-HY)
Preamplifier	Keysight	83017A	MY532701 95	1GHz~26.5GHz	Aug. 23, 2019	Aug. 14, 2020~ Aug. 21, 2020	Aug. 22, 2020	Radiation (03CH15-HY)
Preamplifier	Keysight	83017A	MY532701 95	1GHz~26.5GHz	Aug. 21, 2020	Aug. 21, 2020~ Sep. 08, 2020	Aug. 20, 2021	Radiation (03CH15-HY)
Preamplifier	EMEC	EM18G40G	060715	18GHz ~ 40GHz	Dec. 13, 2019	Aug. 14, 2020~ Sep. 08, 2020	Dec. 12, 2020	Radiation (03CH15-HY)
EMI Test Receiver	Keysight	N9038A(MXE)	MY541300 85	20MHz~8.4GHz	Nov. 01, 2019	Aug. 14, 2020~ Sep. 08, 2020	Oct. 31, 2020	Radiation (03CH15-HY)
Spectrum Analyzer	Agilent	E4446A	MY501801 36	3Hz~44GHz	May 04, 2020	Aug. 14, 2020~ Sep. 08, 2020	May 03, 2021	Radiation (03CH15-HY)
Antenna Mast	ChainTek	MBS-520-1	N/A	1m~4m	N/A	Aug. 14, 2020~ Sep. 08, 2020	N/A	Radiation (03CH15-HY)
Turn Table	ChainTek	T-200-S-1	N/A	0~360 Degree	N/A	Aug. 14, 2020~ Sep. 08, 2020	N/A	Radiation (03CH15-HY)
Software	Audix	E3 6.2009-8-24(k 5)	RK-00045 1	N/A	N/A	Aug. 14, 2020~ Sep. 08, 2020	N/A	Radiation (03CH15-HY)
RF Cable	HUBER + SUHNER	SUCOFLEX 104	MY9837/4 PE	9kHz~30MHz	Mar. 12, 2020	Aug. 14, 2020~ Sep. 08, 2020	Mar. 11, 2021	Radiation (03CH15-HY)
RF Cable	HUBER + SUHNER	SUCOFLEX 104	MY36980/ 4	30M-18G	Apr. 14, 2020	Aug. 14, 2020~ Sep. 08, 2020	Apr. 13, 2021	Radiation (03CH15-HY)
RF Cable	HUBER + SUHNER	SUCOFLEX 104	MY9838/4 PE	30M-18G	Apr. 14, 2020	Aug. 14, 2020~ Sep. 08, 2020	Apr. 13, 2021	Radiation (03CH15-HY)
RF Cable	HUBER + SUHNER	SUCOFLEX 104	MY37710/ 4	30M-18G	Apr. 17, 2020	Aug. 14, 2020~ Sep. 08, 2020	Apr. 16, 2021	Radiation (03CH15-HY)
RF Cable	HUBER + SUHNER	SUCOFLEX 102	505134/2	30MHz-40GHz	Feb. 25, 2020	Aug. 14, 2020~ Sep. 08, 2020	Feb. 24, 2021	Radiation (03CH15-HY)
RF Cable	HUBER + SUHNER	SUCOFLEX 102	800740/2	30MHz-40GHz	Feb. 25, 2020	Aug. 14, 2020~ Sep. 08, 2020	Feb. 24, 2021	Radiation (03CH15-HY)
Filter	Wainwright	WLK4-1000-1 530-8000-40S S	SN4	1.53G Low Pass	Jul. 03, 2020	Aug. 14, 2020~ Sep. 08, 2020	Jul. 02, 2021	Radiation (03CH15-HY)
Filter	Wainwright	WHKX8-5872. 5-6750-18000 -40ST	SN6	6.75GHz High Pass Filter	Jul. 03, 2020	Aug. 14, 2020~ Sep. 08, 2020	Jul. 02, 2021	Radiation (03CH15-HY)



Instrument	Brand Name	Model No.	Serial No.	Characteristics	Calibration Date	Test Date	Due Date	Remark
Hygrometer	Testo	608-H1	34893241	N/A	Mar. 02, 2020	Jul. 25, 2020~ Aug. 26, 2020	Mar. 01, 2021	Conducted (TH05-HY)
Power Sensor	DARE	RPR3006W	16I00054S NO10	10MHz~6GHz	Dec. 23, 2019	Jul. 25, 2020~ Aug. 26, 2020	Dec. 22, 2020	Conducted (TH05-HY)
Signal Analyzer	Rohde & Schwarz	FSV40	101397	10Hz~40GHz	Nov. 15, 2019	Jul. 25, 2020~ Aug. 26, 2020	Nov. 14, 2020	Conducted (TH05-HY)
Spectrum Analyzer	Rohde & Schwarz	FSP40	100055	9kHz-40GHz	Dec. 30, 2019	Jul. 25, 2020~ Aug. 26, 2020	Dec. 29, 2020	Conducted (TH05-HY)
Programmable Power Supply	GW Instek	GPP-2323	GES90603 7	0V~64V ; 0A~6A	Dec. 13, 2019	Jul. 25, 2020~ Aug. 26, 2020	Dec. 12, 2020	Conducted (TH05-HY)
Switch Control Manframe	EM Electronics	EMSW18SE	SW200302	N/A	Mar. 17, 2020	Jul. 25, 2020~ Aug. 26, 2020	Mar. 16, 2021	Conducted (TH05-HY)
AC Power Source	ChainTek	APC-1000W	N/A	N/A	N/A	Jul. 23, 2020	N/A	Conduction (CO05-HY)
EMI Test Receiver	Rohde & Schwarz	ESR3	102388	9kHz~3.6GHz	Nov. 15, 2019	Jul. 23, 2020	Nov. 14, 2020	Conduction (CO05-HY)
Hygrometer	Testo	608-H1	34913912	N/A	Nov. 07, 2019	Jul. 23, 2020	Nov. 06, 2020	Conduction (CO05-HY)
LISN	Rohde & Schwarz	ENV216	100081	9kHz~30MHz	Nov. 15, 2019	Jul. 23, 2020	Nov. 14, 2020	Conduction (CO05-HY)
Software	Rohde & Schwarz	EMC32 V10.30	N/A	N/A	N/A	Jul. 23, 2020	N/A	Conduction (CO05-HY)
LF Cable	HUBER + SUHNER	RG-214/U	LF01	N/A	Jan. 02, 2020	Jul. 23, 2020	Jan. 01, 2021	Conduction (CO05-HY)
Pulse Limiter	Rohde & Schwarz	ESH3-Z2	100851	N/A	Jan. 02, 2020	Jul. 23, 2020	Jan. 01, 2021	Conduction (CO05-HY)



5 Uncertainty of Evaluation

Uncertainty of Conducted Emission Measurement (150kHz ~ 30MHz)

Measuring Uncertainty for a Level of Confidence of 95% ($U = 2Uc(y)$)	2.3
---	-----

Uncertainty of Radiated Emission Measurement (30 MHz ~ 1000 MHz)

Measuring Uncertainty for a Level of Confidence of 95% ($U = 2Uc(y)$)	5.0
---	-----

Uncertainty of Radiated Emission Measurement (1000 MHz ~ 18000 MHz)

Measuring Uncertainty for a Level of Confidence of 95% ($U = 2Uc(y)$)	5.4
---	-----

Uncertainty of Radiated Emission Measurement (18000 MHz ~ 40000 MHz)

Measuring Uncertainty for a Level of Confidence of 95% ($U = 2Uc(y)$)	5.0
---	-----

Appendix A. Test Result of Conducted Test Items

Test Engineer:	Sylvia Li / Kai Liao	Temperature:	23.1~23.7	°C
Test Date:	2020/07/25~2020/08/26	Relative Humidity:	53.1~53.5	%

TEST RESULTS DATA
6dB and 26dB EBW and 99% OBW

Band IV MIMO												
Mod.	Data Rate	NTX	CH.	Freq. (MHz)	99% Bandwidth (MHz)		26dB Bandwidth (MHz)		6 dB Bandwidth (MHz)		6 dB Bandwidth Min. Limit (MHz)	Pass/Fail
					Ant 0	Ant 1	Ant 0	Ant 1	Ant 0	Ant 1		
11a	6Mbps	2	149	5745	16.38	16.38	20.90	20.55	16.34	16.29	0.5	Pass
11a	6Mbps	2	157	5785	16.38	16.38	20.45	20.80	16.29	16.24	0.5	Pass
11a	6Mbps	2	165	5825	16.38	16.38	20.65	20.70	16.34	15.99	0.5	Pass

TEST RESULTS DATA
Average Power Table

Band IV single antenna												
Mod.	Data Rate	NTX	CH.	Freq. (MHz)	Average Conducted Power (dBm)			FCC Conducted Power Limit (dBm)		DG (dBi)		Pass/Fail
					Ant 0	Ant 1	SUM	Ant 0	Ant 1	Ant 0	Ant 1	
11a	6Mbps	1	149	5745	11.8	12.0		30.00	30.00	4.50	2.40	Pass
11a	6Mbps	1	157	5785	11.7	12.3		30.00	30.00	4.50	2.40	Pass
11a	6Mbps	1	165	5825	11.8	12.4		30.00	30.00	4.50	2.40	Pass
HT20	MCS0	1	149	5745	11.7	12.2		30.00	30.00	4.50	2.40	Pass
HT20	MCS0	1	157	5785	11.6	12.0		30.00	30.00	4.50	2.40	Pass
HT20	MCS0	1	165	5825	11.6	12.2		30.00	30.00	4.50	2.40	Pass
HT40	MCS0	1	151	5755	11.8	12.0		30.00	30.00	4.50	2.40	Pass
HT40	MCS0	1	159	5795	11.6	11.9		30.00	30.00	4.50	2.40	Pass
VHT20	MCS0	1	149	5745	11.7	12.0		30.00	30.00	4.50	2.40	Pass
VHT20	MCS0	1	157	5785	11.5	11.9		30.00	30.00	4.50	2.40	Pass
VHT20	MCS0	1	165	5825	11.6	12.1		30.00	30.00	4.50	2.40	Pass
VHT40	MCS0	1	151	5755	11.7	12.0		30.00	30.00	4.50	2.40	Pass
VHT40	MCS0	1	159	5795	11.5	11.8		30.00	30.00	4.50	2.40	Pass
VHT80	MCS0	1	155	5775	11.8	11.8		30.00	30.00	4.50	2.40	Pass

Band IV MIMO												
Mod.	Data Rate	NTX	CH.	Freq. (MHz)	Average Conducted Power (dBm)			FCC Conducted Power Limit (dBm)		DG (dBi)		Pass/Fail
					Ant 0	Ant 1	SUM	Ant 0	Ant 1	Ant 0	Ant 1	
11a	6Mbps	2	149	5745	13.5	11.5	15.6	30.00		4.50		Pass
11a	6Mbps	2	157	5785	13.2	11.7	15.5	30.00		4.50		Pass
11a	6Mbps	2	165	5825	13.1	12.0	15.6	30.00		4.50		Pass
HT20	MCS0	2	149	5745	13.7	11.7	15.8	30.00		4.50		Pass
HT20	MCS0	2	157	5785	13.2	11.4	15.4	30.00		4.50		Pass
HT20	MCS0	2	165	5825	13.1	11.6	15.4	30.00		4.50		Pass
HT40	MCS0	2	151	5755	13.4	11.6	15.6	30.00		4.50		Pass
HT40	MCS0	2	159	5795	13.2	11.7	15.5	30.00		4.50		Pass
VHT20	MCS0	2	149	5745	13.6	11.6	15.7	30.00		4.50		Pass
VHT20	MCS0	2	157	5785	13.2	11.4	15.4	30.00		4.50		Pass
VHT20	MCS0	2	165	5825	13.1	11.6	15.4	30.00		4.50		Pass
VHT40	MCS0	2	151	5755	13.4	11.6	15.6	30.00		4.50		Pass
VHT40	MCS0	2	159	5795	13.2	11.6	15.5	30.00		4.50		Pass
VHT80	MCS0	2	155	5775	13.3	11.6	15.5	30.00		4.50		Pass

TEST RESULTS DATA
Power Spectral Density

Band IV MIMO														
Mod.	Data Rate	NTX	CH.	Freq. (MHz)	10log (500kHz /RBW) Factor (dB)		Average Power Density (dBm/500kHz)			Average PSD Limit (dBm/500kHz)		DG (dBi)		Pass /Fail
					Ant 0	Ant 1	Ant 0	Ant 1	SUM	Ant 0	Ant 1	Ant 0	Ant 1	
11a	6Mbps	2	149	5745	2.22		1.97	0.47	4.98	29.48		6.52		Pass
11a	6Mbps	2	157	5785	2.22		2.69	0.78	5.70	29.48		6.52		Pass
11a	6Mbps	2	165	5825	2.22		1.70	0.75	4.71	29.48		6.52		Pass

Note: PSD Sum = Max PSD(Ant. 1, Ant. 2) + 10 log (n)

TEST RESULTS DATA
6dB and 26dB EBW and 99% OBW

Band IV MIMO													
Mod.	Data Rate	NTX	CH.	Freq. (MHz)	RU Config	99% Bandwidth (MHz)		26dB Bandwidth (MHz)		6 dB Bandwidth (MHz)		6 dB Bandwidth Min. Limit (MHz)	Pass/Fail
						Ant 0	Ant 1	Ant 0	Ant 1	Ant 0	Ant 1		
HE20	MCS0	2	149	5745	Full	18.88	18.88	22.00	21.95	18.24	18.64	0.5	Pass
HE20	MCS0	2	157	5785	Full	18.88	18.88	22.20	22.05	18.99	18.74	0.5	Pass
HE20	MCS0	2	165	5825	Full	18.88	18.88	22.15	22.25	18.29	18.89	0.5	Pass
HE40	MCS0	2	151	5755	Full	37.76	37.76	41.31	41.13	37.24	37.15	0.5	Pass
HE40	MCS0	2	159	5795	Full	37.96	37.86	41.49	41.13	36.79	37.89	0.5	Pass
HE80	MCS0	2	155	5775	Full	77.80	77.80	81.92	82.08	75.96	77.12	0.5	Pass

TEST RESULTS DATA
Average Power Table

Band IV single antenna													
Mod.	Data Rate	NTX	CH.	Freq. (MHz)	RU Config	Average Conducted Power (dBm)			FCC Conducted Power Limit (dBm)		DG (dBi)		Pass/Fail
						Ant 0	Ant 1	SUM	Ant 0	Ant 1	Ant 0	Ant 1	
HE20	MCS0	1	149	5745	Full	11.8	12.3		30.00	30.00	4.50	2.40	Pass
HE20	MCS0	1	149	5745	26/0	6.0	6.1		30.00	30.00	4.50	2.40	Pass
HE20	MCS0	1	149	5745	52/37	10.8	9.4		30.00	30.00	4.50	2.40	Pass
HE20	MCS0	1	149	5745	106/53	12.4	12.8		30.00	30.00	4.50	2.40	Pass
HE20	MCS0	1	157	5785	Full	11.7	12.1		30.00	30.00	4.50	2.40	Pass
HE20	MCS0	1	157	5785	26/4	5.6	5.6		30.00	30.00	4.50	2.40	Pass
HE20	MCS0	1	165	5825	Full	11.8	12.3		30.00	30.00	4.50	2.40	Pass
HE20	MCS0	1	165	5825	26/8	5.5	5.1		30.00	30.00	4.50	2.40	Pass
HE20	MCS0	1	165	5825	52/40	8.8	8.2		30.00	30.00	4.50	2.40	Pass
HE20	MCS0	1	165	5825	106/54	11.5	11.2		30.00	30.00	4.50	2.40	Pass
HE40	MCS0	1	151	5755	Full	11.9	12.2		30.00	30.00	4.50	2.40	Pass
HE40	MCS0	1	151	5755	242/61	11.8	11.9		30.00	30.00	4.50	2.40	Pass
HE40	MCS0	1	159	5795	Full	11.7	12.2		30.00	30.00	4.50	2.40	Pass
HE40	MCS0	1	159	5795	242/62	11.9	11.8		30.00	30.00	4.50	2.40	Pass
HE80	MCS0	1	155	5775	Full	11.9	12.0		30.00	30.00	4.50	2.40	Pass
HE80	MCS0	1	155	5775	484/65	11.10	10.80		30.00	30.00	4.50	2.40	Pass
HE80	MCS0	1	155	5775	484/66	10.70	10.40		30.00	30.00	4.50	2.40	Pass

Band IV MIMO													
Mod.	Data Rate	NTX	CH.	Freq. (MHz)	RU Config	Average Conducted Power (dBm)			FCC Conducted Power Limit (dBm)		DG (dBi)		Pass/Fail
						Ant 0	Ant 1	SUM	Ant 0	Ant 1	Ant 0	Ant 1	
HE20	MCS0	2	149	5745	Full	13.8	11.8	15.9	30.00		4.50		Pass
HE20	MCS0	2	149	5745	26/0	6.1	6.2	9.2	30.00		4.50		Pass
HE20	MCS0	2	149	5745	52/37	10.9	9.5	13.3	30.00		4.50		Pass
HE20	MCS0	2	149	5745	106/53	12.5	12.9	15.7	30.00		4.50		Pass
HE20	MCS0	2	157	5785	Full	13.3	11.5	15.5	30.00		4.50		Pass
HE20	MCS0	2	157	5785	26/4	5.7	5.7	8.7	30.00		4.50		Pass
HE20	MCS0	2	165	5825	Full	13.2	11.8	15.6	30.00		4.50		Pass
HE20	MCS0	2	165	5825	26/8	5.6	5.2	8.4	30.00		4.50		Pass
HE20	MCS0	2	165	5825	52/40	8.9	8.3	11.6	30.00		4.50		Pass
HE20	MCS0	2	165	5825	106/54	11.6	11.3	14.5	30.00		4.50		Pass
HE40	MCS0	2	151	5755	Full	13.4	11.5	15.6	30.00		4.50		Pass
HE40	MCS0	2	151	5755	242/61	11.9	12.0	15.0	30.00		4.50		Pass
HE40	MCS0	2	159	5795	Full	13.6	12.0	15.9	30.00		4.50		Pass
HE40	MCS0	2	159	5795	242/62	12.0	11.9	15.0	30.00		4.50		Pass
HE80	MCS0	2	155	5775	Full	13.2	11.7	15.5	30.00		4.50		Pass
HE80	MCS0	2	155	5775	484/65	11.20	10.90	14.06	30.00		4.50		Pass
HE80	MCS0	2	155	5775	484/66	10.80	10.50	13.66	30.00		4.50		Pass

TEST RESULTS DATA
Power Spectral Density

Band IV MIMO															
Mod.	Data Rate	NTX	CH.	Freq. (MHz)	RU Config	10log (500kHz /RBW) Factor (dB)		Average Power Density (dBm/500kHz)			Average PSD Limit (dBm/500kHz)		DG (dBi)		Pass /Fail
						Ant 0	Ant 1	Ant 0	Ant 1	SUM	Ant 0	Ant 1	Ant 0	Ant 1	
HE20	MCS0	2	149	5745	Full	2.22	3.12	0.80	6.13	29.48	29.48	6.52	6.52	Pass	
HE20	MCS0	2	149	5745	26/0	2.22	2.02	2.59	5.60	29.48	29.48	6.52	6.52	Pass	
HE20	MCS0	2	149	5745	52/37	2.22	2.40	2.70	5.71	29.48	29.48	6.52	6.52	Pass	
HE20	MCS0	2	149	5745	106/53	2.22	2.60	2.77	5.78	29.48	29.48	6.52	6.52	Pass	
HE20	MCS0	2	157	5785	Full	2.22	2.21	0.43	5.22	29.48	29.48	6.52	6.52	Pass	
HE20	MCS0	2	157	5785	26/4	2.22	2.08	2.13	5.14	29.48	29.48	6.52	6.52	Pass	
HE20	MCS0	2	165	5825	Full	2.22	2.25	0.61	5.26	29.48	29.48	6.52	6.52	Pass	
HE20	MCS0	2	165	5825	26/8	2.22	1.78	1.31	4.79	29.48	29.48	6.52	6.52	Pass	
HE20	MCS0	2	165	5825	52/40	2.22	2.02	1.67	5.03	29.48	29.48	6.52	6.52	Pass	
HE20	MCS0	2	165	5825	106/54	2.22	2.01	1.62	5.02	29.48	29.48	6.52	6.52	Pass	
HE40	MCS0	2	151	5755	Full	2.22	-0.62	-2.11	2.39	29.48	29.48	6.52	6.52	Pass	
HE40	MCS0	2	151	5755	242/61	2.22	-1.14	-1.01	2.00	29.48	29.48	6.52	6.52	Pass	
HE40	MCS0	2	159	5795	Full	2.22	-0.76	-2.16	2.25	29.48	29.48	6.52	6.52	Pass	
HE40	MCS0	2	159	5795	242/62	2.22	-1.10	-1.09	1.92	29.48	29.48	6.52	6.52	Pass	
HE80	MCS0	2	155	5775	Full	2.22	-4.36	-5.21	-1.35	29.48	29.48	6.52	6.52	Pass	
HE80	MCS0	2	155	5775	484/65	2.22	-4.77	-5.05	-1.76	29.48	29.48	6.52	6.52	Pass	
HE80	MCS0	2	155	5775	484/66	2.22	-4.55	-4.99	-1.54	29.48	29.48	6.52	6.52	Pass	

Note: PSD Sum = Max PSD(Ant. 1, Ant. 2) + 10 log (n)



Appendix B. AC Conducted Emission Test Results

Test Engineer :	Howard Huang	Temperature :	23~25°C
		Relative Humidity :	42~50%

EUT Information

Report NO : 041657
 Test Mode : Mode 1
 Test Voltage : 120Vac/60Hz
 Phase : Line

Full Spectrum

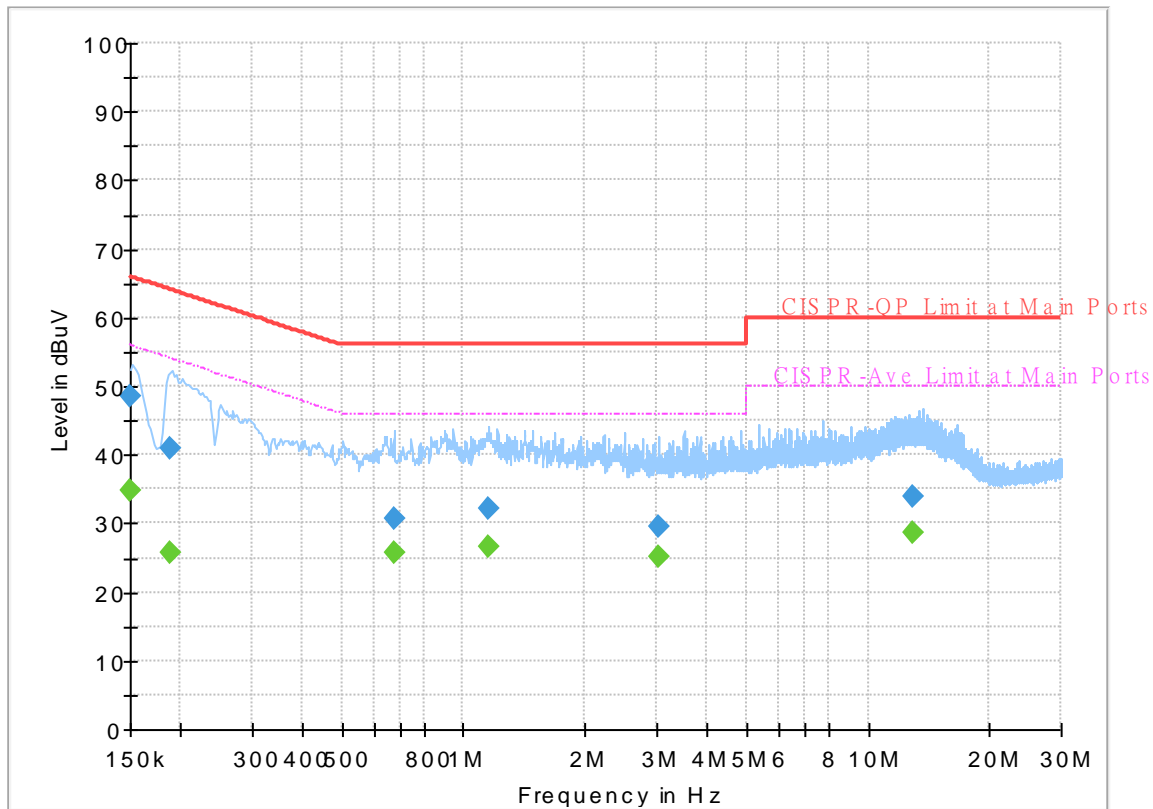

Final Result

Frequency (MHz)	QuasiPeak (dBuV)	CAverage (dBuV)	Limit (dBuV)	Margin (dB)	Line	Filter	Corr. (dB)
0.150000	48.66	---	66.00	17.34	L1	OFF	19.6
0.150000	---	34.94	56.00	21.06	L1	OFF	19.6
0.189420	40.84	---	64.06	23.22	L1	OFF	19.6
0.189420	---	25.59	54.06	28.47	L1	OFF	19.6
0.678750	30.72	---	56.00	25.28	L1	OFF	19.6
0.678750	---	25.60	46.00	20.40	L1	OFF	19.6
1.153950	32.25	---	56.00	23.75	L1	OFF	19.6
1.153950	---	26.74	46.00	19.26	L1	OFF	19.6
3.029190	29.54	---	56.00	26.46	L1	OFF	19.7
3.029190	---	25.29	46.00	20.71	L1	OFF	19.7
12.871500	33.79	---	60.00	26.21	L1	OFF	20.2
12.871500	---	28.51	50.00	21.49	L1	OFF	20.2

EUT Information

Report NO : 041657
 Test Mode : Mode 1
 Test Voltage : 120Vac/60Hz
 Phase : Neutral

Full Spectrum

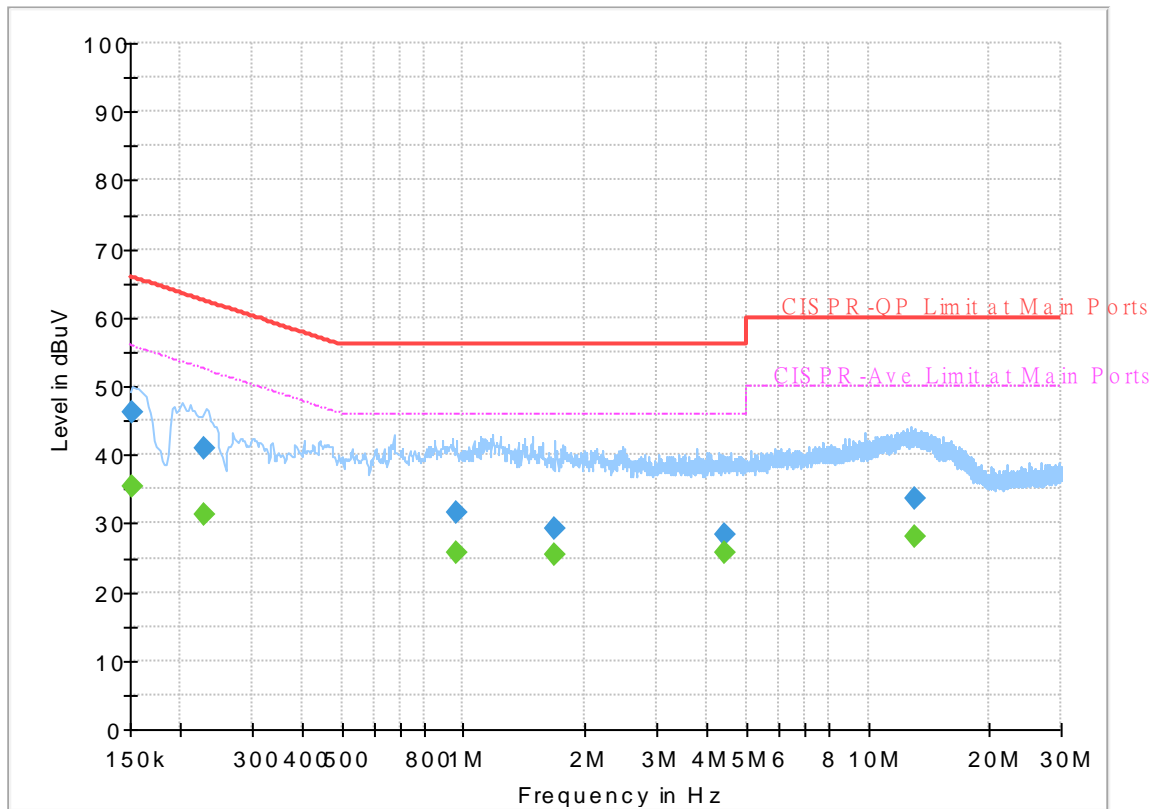

Final_Result

Frequency (MHz)	QuasiPeak (dBuV)	CAverage (dBuV)	Limit (dBuV)	Margin (dB)	Line	Filter	Corr. (dB)
0.151620	---	35.26	55.91	20.65	N	OFF	19.5
0.151620	46.18	---	65.91	19.73	N	OFF	19.5
0.228660	---	31.21	52.50	21.29	N	OFF	19.5
0.228660	40.80	---	62.50	21.70	N	OFF	19.5
0.962700	---	25.86	46.00	20.14	N	OFF	19.6
0.962700	31.67	---	56.00	24.33	N	OFF	19.6
1.675590	---	25.42	46.00	20.58	N	OFF	19.6
1.675590	29.14	---	56.00	26.86	N	OFF	19.6
4.402500	---	25.67	46.00	20.33	N	OFF	19.6
4.402500	28.36	---	56.00	27.64	N	OFF	19.6
13.043130	---	28.14	50.00	21.86	N	OFF	19.9
13.043130	33.63	---	60.00	26.37	N	OFF	19.9



Appendix C. Radiated Spurious Emission

Test Engineer :	Leo Lee, Mancy Chou, and Bigshow Wang	Temperature :	22.1~24.0°C
		Relative Humidity :	45~59%

Band 4 - 5725~5850MHz
WIFI 802.11a (Band Edge @ 3m)

WIFI Ant.	Note	Frequency (MHz)	Level (dBμV/m)	Over Limit (dB)	Limit Line (dBμV/m)	Read Level (dBμV)	Antenna Factor (dB/m)	Path Loss (dB)	Preamp Factor (dB)	Ant Pos (cm)	Table Pos (deg)	Peak Avg. (P/A)	Pol. (H/V)	
802.11a CH 149 5745MHz		5617.6	52.54	-15.66	68.2	39.86	31.86	10.89	30.07	100	30	P	H	
		5694	51.94	-48.84	100.78	39.21	31.98	10.88	30.13	100	30	P	H	
		5718.8	52.9	-57.56	110.46	40.18	32	10.87	30.15	100	30	P	H	
		5722.2	52.65	-63.17	115.82	39.93	32	10.87	30.15	100	30	P	H	
	*	5745	109.26	-	-	96.57	32	10.86	30.17	100	30	P	H	
	*	5745	101.42	-	-	88.73	32	10.86	30.17	100	30	A	H	
														H
														H
			5623.4	52.47	-15.73	68.2	39.81	31.85	10.89	30.08	400	242	P	V
			5683	52.22	-40.44	92.66	39.53	31.93	10.88	30.12	400	242	P	V
			5705	51.62	-54.98	106.6	38.89	32	10.87	30.14	400	242	P	V
			5724.2	52.81	-67.57	120.38	40.09	32	10.87	30.15	400	242	P	V
	*	5745	107.12	-	-	94.43	32	10.86	30.17	400	242	P	V	
	*	5745	98.55	-	-	85.86	32	10.86	30.17	400	242	A	V	
														V
													V	



WIFI Ant. 0+1	Note	Frequency (MHz)	Level (dBμV/m)	Over Limit (dB)	Limit Line (dBμV/m)	Read Level (dBμV)	Antenna Factor (dB/m)	Path Loss (dB)	Preamp Factor (dB)	Ant Pos (cm)	Table Pos (deg)	Peak Avg. (P/A)	Pol. (H/V)
		5601	52.37	-15.83	68.2	39.63	31.9	10.9	30.06	100	34	P	H
		5659.2	52.78	-22.25	75.03	40.16	31.84	10.88	30.1	100	34	P	H
		5707	52.51	-54.65	107.16	39.78	32	10.87	30.14	100	34	P	H
		5722	52.13	-63.23	115.36	39.41	32	10.87	30.15	100	34	P	H
	*	5785	112.46	-	-	99.67	32.14	10.85	30.2	100	34	P	H
	*	5785	104.76	-	-	91.97	32.14	10.85	30.2	100	34	A	H
		5854.8	51.72	-59.54	111.26	38.76	32.22	10.99	30.25	100	34	P	H
		5867.2	53.28	-54.1	107.38	40.24	32.27	11.02	30.25	100	34	P	H
		5914.2	52.76	-23.41	76.17	39.48	32.43	11.14	30.29	100	34	P	H
		5941.4	51.81	-16.39	68.2	38.43	32.48	11.21	30.31	100	34	P	H
													H
													H
802.11a													
CH 157													
5785MHz		5644.6	52.07	-16.13	68.2	39.46	31.81	10.89	30.09	371	244	P	V
		5695.8	51.56	-50.54	102.1	38.84	31.98	10.87	30.13	371	244	P	V
		5717.8	51.12	-59.06	110.18	38.4	32	10.87	30.15	371	244	P	V
		5722	52.23	-63.13	115.36	39.51	32	10.87	30.15	371	244	P	V
	*	5785	109.07	-	-	96.28	32.14	10.85	30.2	371	244	P	V
	*	5785	101.35	-	-	88.56	32.14	10.85	30.2	371	244	A	V
		5854.2	51.18	-61.44	112.62	38.22	32.22	10.99	30.25	371	244	P	V
		5874.8	52.37	-52.89	105.26	39.29	32.3	11.04	30.26	371	244	P	V
		5916.4	53.25	-21.29	74.54	39.97	32.43	11.14	30.29	371	244	P	V
		5935	52.58	-15.62	68.2	39.22	32.47	11.19	30.3	371	244	P	V
													V
													V



WiFi Ant. 0+1	Note	Frequency (MHz)	Level (dBμV/m)	Over Limit (dB)	Limit Line (dBμV/m)	Read Level (dBμV)	Antenna Factor (dB/m)	Path Loss (dB)	Preamp Factor (dB)	Ant Pos (cm)	Table Pos (deg)	Peak Avg. (P/A)	Pol. (H/V)	
802.11a CH 165 5825MHz	*	5825	109.12	-	-	96.23	32.2	10.91	30.22	100	33	P	H	
	*	5825	101.27	-	-	88.38	32.2	10.91	30.22	100	33	A	H	
		5852.8	52.13	-63.69	115.82	39.18	32.21	10.98	30.24	100	33	P	H	
		5870.8	52.26	-54.11	106.37	39.21	32.28	11.03	30.26	100	33	P	H	
		5920	52.43	-19.46	71.89	39.13	32.44	11.15	30.29	100	33	P	H	
		5948.8	52.21	-15.99	68.2	38.8	32.5	11.22	30.31	100	33	P	H	
														H
														H
	*	5825	105.2	-	-	92.31	32.2	10.91	30.22	399	137	P	V	
	*	5825	97.55	-	-	84.66	32.2	10.91	30.22	399	137	A	V	
		5850.2	52.86	-68.88	121.74	39.92	32.2	10.98	30.24	399	137	P	V	
		5872	52.3	-53.74	106.04	39.24	32.29	11.03	30.26	399	137	P	V	
		5915.4	52.6	-22.68	75.28	39.32	32.43	11.14	30.29	399	137	P	V	
		5939.4	52.47	-15.73	68.2	39.1	32.48	11.2	30.31	399	137	P	V	
														V
														V
													V	
Remark	1. No other spurious found. 2. All results are PASS against Peak and Average limit line.													



Band 4 5725~5850MHz
WIFI 802.11a (Harmonic @ 3m)

WIFI Ant. 0+1	Note	Frequency (MHz)	Level (dBµV/m)	Over Limit (dB)	Limit Line (dBµV/m)	Read Level (dBµV)	Antenna Factor (dB/m)	Path Loss (dB)	Preamp Factor (dB)	Ant Pos (cm)	Table Pos (deg)	Peak Avg. (P/A)	Pol. (H/V)	
802.11a CH 149 5745MHz		11490	48.04	-25.96	74	53.57	40.48	14.89	60.9	100	0	P	H	
		17235	50.75	-17.45	68.2	49.66	40.94	18.97	58.82	100	0	P	H	
													H	
													H	
			11490	49.33	-24.67	74	54.86	40.48	14.89	60.9	100	0	P	V
			17235	49.64	-18.56	68.2	48.55	40.94	18.97	58.82	100	0	P	V
														V
802.11a CH 157 5785MHz		11570	48.76	-25.24	74	54.47	40.29	14.98	60.98	100	0	P	H	
		17355	52.24	-15.96	68.2	50.05	41.75	19.11	58.67	100	0	P	H	
													H	
													H	
			11570	49.9	-24.1	74	55.61	40.29	14.98	60.98	100	0	P	V
			17355	52.23	-15.97	68.2	50.04	41.75	19.11	58.67	100	0	P	V
														V
802.11a CH 165 5825MHz		11650	49.06	-24.94	74	55.23	39.85	15.06	61.08	100	0	P	H	
		17475	52.52	-15.68	68.2	49.31	42.5	19.24	58.53	100	0	P	H	
													H	
													H	
			11650	48.92	-25.08	74	55.09	39.85	15.06	61.08	100	0	P	V
			17475	53.4	-14.8	68.2	50.19	42.5	19.24	58.53	100	0	P	V
														V
Remark	1. No other spurious found.													
	2. All results are PASS against Peak and Average limit line.													



Band 4 5725~5850MHz
WIFI 802.11ax HE20_Partial 26 (Band Edge @ 3m)

WIFI Ant. 0+1	Note	Frequency (MHz)	Level (dBμV/m)	Over Limit (dB)	Limit Line (dBμV/m)	Read Level (dBμV)	Antenna Factor (dB/m)	Path Loss (dB)	Preamp Factor (dB)	Ant Pos (cm)	Table Pos (deg)	Peak Avg. (P/A)	Pol. (H/V)	
802.11ax HE20 Partial 26/0 CH 149 5745MHz		5624.6	51.8	-16.4	68.2	39.14	31.85	10.89	30.08	100	6	P	H	
		5660.2	51.28	-24.49	75.77	38.67	31.84	10.88	30.11	100	6	P	H	
		5702.4	52.33	-53.54	105.87	39.6	32	10.87	30.14	100	6	P	H	
		5723.2	51.35	-66.75	118.1	38.63	32	10.87	30.15	100	6	P	H	
	*	5745	113.36	-	-	100.67	32	10.86	30.17	100	6	P	H	
	*	5745	103.98	-	-	91.29	32	10.86	30.17	100	6	A	H	
														H
														H
			5603.6	52.61	-15.59	68.2	39.88	31.89	10.9	30.06	288	143	P	V
			5688.2	53.42	-43.08	96.5	40.72	31.95	10.88	30.13	288	143	P	V
			5702.6	53.43	-52.5	105.93	40.7	32	10.87	30.14	288	143	P	V
			5724.2	56.22	-64.16	120.38	43.5	32	10.87	30.15	288	143	P	V
	*		5745	111.01	-	-	98.32	32	10.86	30.17	288	143	P	V
	*		5745	101.63	-	-	88.94	32	10.86	30.17	288	143	A	V
													V	
													V	



WIFI Ant. 0+1	Note	Frequency (MHz)	Level (dBµV/m)	Over Limit (dB)	Limit Line (dBµV/m)	Read Level (dBµV)	Antenna Factor (dB/m)	Path Loss (dB)	Preamp Factor (dB)	Ant Pos (cm)	Table Pos (deg)	Peak Avg. (P/A)	Pol. (H/V)
		5607.4	52.51	-15.69	68.2	39.79	31.89	10.9	30.07	100	10	P	H
		5659.6	51.93	-23.4	75.33	39.31	31.84	10.88	30.1	100	10	P	H
		5711.4	51.86	-56.53	108.39	39.13	32	10.87	30.14	100	10	P	H
		5722.6	51.02	-65.71	116.73	38.3	32	10.87	30.15	100	10	P	H
	*	5785	111.34	-	-	98.55	32.14	10.85	30.2	100	10	P	H
	*	5785	102.21	-	-	89.42	32.14	10.85	30.2	100	10	A	H
		5850.8	50.61	-69.77	120.38	37.67	32.2	10.98	30.24	100	10	P	H
		5874.8	51.74	-53.52	105.26	38.66	32.3	11.04	30.26	100	10	P	H
		5878.8	51.93	-50.45	102.38	38.82	32.32	11.05	30.26	100	10	P	H
		5949.2	51.72	-16.48	68.2	38.31	32.5	11.22	30.31	100	10	P	H
802.11ax													H
HE20													H
Partial 26/4													
CH 157		5600.4	52.1	-16.1	68.2	39.36	31.9	10.9	30.06	299	147	P	V
5785MHz		5685	51.45	-42.68	94.13	38.75	31.94	10.88	30.12	299	147	P	V
		5712.6	51.35	-57.38	108.73	38.62	32	10.87	30.14	299	147	P	V
		5720.2	51.47	-59.79	111.26	38.75	32	10.87	30.15	299	147	P	V
	*	5785	109.02	-	-	96.23	32.14	10.85	30.2	299	147	P	V
	*	5785	100.08	-	-	87.29	32.14	10.85	30.2	299	147	A	V
		5852	51.03	-66.61	117.64	38.08	32.21	10.98	30.24	299	147	P	V
		5873.2	52.52	-53.18	105.7	39.46	32.29	11.03	30.26	299	147	P	V
		5897.6	51.91	-36.53	88.44	38.7	32.39	11.1	30.28	299	147	P	V
		5943.4	51.92	-16.28	68.2	38.53	32.49	11.21	30.31	299	147	P	V
													V
													V



WiFi Ant. 0+1	Note	Frequency (MHz)	Level (dBμV/m)	Over Limit (dB)	Limit Line (dBμV/m)	Read Level (dBμV)	Antenna Factor (dB/m)	Path Loss (dB)	Preamp Factor (dB)	Ant Pos (cm)	Table Pos (deg)	Peak Avg. (P/A)	Pol. (H/V)	
802.11ax HE20 Partial 26/8 CH 165 5825MHz	*	5825	113.35	-	-	100.46	32.2	10.91	30.22	100	12	P	H	
	*	5825	102.54	-	-	89.65	32.2	10.91	30.22	100	12	A	H	
		5853.2	51.99	-62.91	114.9	39.04	32.21	10.98	30.24	100	12	P	H	
		5868.4	51.85	-55.2	107.05	38.82	32.27	11.02	30.26	100	12	P	H	
		5889.2	52.54	-42.12	94.66	39.38	32.36	11.07	30.27	100	12	P	H	
		5937.4	51.87	-16.33	68.2	38.5	32.47	11.2	30.3	100	12	P	H	
														H
														H
	*	5825	111.09	-	-	98.2	32.2	10.91	30.22	287	201	P	V	
	*	5825	100.15	-	-	87.26	32.2	10.91	30.22	287	201	A	V	
		5851	51.21	-68.71	119.92	38.27	32.2	10.98	30.24	287	201	P	V	
		5872.6	51.86	-54.01	105.87	38.8	32.29	11.03	30.26	287	201	P	V	
		5921	52.68	-18.47	71.15	39.38	32.44	11.15	30.29	287	201	P	V	
		5949.6	52.62	-15.58	68.2	39.2	32.5	11.23	30.31	287	201	P	V	
														V
														V
Remark	1. No other spurious found. 2. All results are PASS against Peak and Average limit line.													



Band 4 5725~5850MHz
WIFI 802.11ax HE20_Partial 52 (Band Edge @ 3m)

WIFI Ant. 0+1	Note	Frequency (MHz)	Level (dBμV/m)	Over Limit (dB)	Limit Line (dBμV/m)	Read Level (dBμV)	Antenna Factor (dB/m)	Path Loss (dB)	Preamp Factor (dB)	Ant Pos (cm)	Table Pos (deg)	Peak Avg. (P/A)	Pol. (H/V)	
802.11ax HE20 Partial 52/37 CH 149 5745MHz		5623.8	51.8	-16.4	68.2	39.14	31.85	10.89	30.08	100	7	P	H	
		5665.4	51.47	-28.16	79.63	38.84	31.86	10.88	30.11	100	7	P	H	
		5715.2	52.66	-56.8	109.46	39.93	32	10.87	30.14	100	7	P	H	
		5724.4	64.25	-56.58	120.83	51.53	32	10.87	30.15	100	7	P	H	
	*	5745	115.14	-	-	102.45	32	10.86	30.17	100	7	P	H	
	*	5745	104.29	-	-	91.6	32	10.86	30.17	100	7	A	H	
														H
														H
			5616.2	51.49	-16.71	68.2	38.8	31.87	10.89	30.07	288	144	P	V
			5696	50.96	-51.29	102.25	38.24	31.98	10.87	30.13	288	144	P	V
			5718.4	52.19	-58.16	110.35	39.47	32	10.87	30.15	288	144	P	V
			5721.4	51.85	-62.14	113.99	39.13	32	10.87	30.15	288	144	P	V
	*		5745	112.37	-	-	99.68	32	10.86	30.17	288	144	P	V
	*		5745	101.89	-	-	89.2	32	10.86	30.17	288	144	A	V
														V
													V	



WIFI Ant. 0+1	Note	Frequency (MHz)	Level (dBμV/m)	Over Limit (dB)	Limit Line (dBμV/m)	Read Level (dBμV)	Antenna Factor (dB/m)	Path Loss (dB)	Preamp Factor (dB)	Ant Pos (cm)	Table Pos (deg)	Peak Avg. (P/A)	Pol. (H/V)	
802.11ax HE20 Partial 52/40 CH 165 5825MHz	*	5825	112.64	-	-	99.75	32.2	10.91	30.22	100	10	P	H	
	*	5825	102.67	-	-	89.78	32.2	10.91	30.22	100	10	A	H	
		5852.6	51.54	-64.73	116.27	38.59	32.21	10.98	30.24	100	10	P	H	
		5860.6	51.61	-57.62	109.23	38.62	32.24	11	30.25	100	10	P	H	
		5879.6	52.06	-49.72	101.78	38.95	32.32	11.05	30.26	100	10	P	H	
		5942.8	51.95	-16.25	68.2	38.56	32.49	11.21	30.31	100	10	P	H	
														H
														H
	*	5825	110.77	-	-	97.88	32.2	10.91	30.22	331	201	P	V	
	*	5825	100.53	-	-	87.64	32.2	10.91	30.22	331	201	A	V	
		5852.6	52.1	-64.17	116.27	39.15	32.21	10.98	30.24	331	201	P	V	
		5860.8	52.32	-56.85	109.17	39.33	32.24	11	30.25	331	201	P	V	
		5904	52.68	-31.02	83.7	39.44	32.41	11.11	30.28	331	201	P	V	
		5937.4	52.45	-15.75	68.2	39.08	32.47	11.2	30.3	331	201	P	V	
														V
													V	
Remark	1. No other spurious found. 2. All results are PASS against Peak and Average limit line.													



Band 4 5725~5850MHz
WIFI 802.11ax HE20_Partial 106 (Band Edge @ 3m)

WIFI Ant. 0+1	Note	Frequency (MHz)	Level (dBμV/m)	Over Limit (dB)	Limit Line (dBμV/m)	Read Level (dBμV)	Antenna Factor (dB/m)	Path Loss (dB)	Preamp Factor (dB)	Ant Pos (cm)	Table Pos (deg)	Peak Avg. (P/A)	Pol. (H/V)	
802.11ax HE20 Partial 106/53 CH 149 5745MHz		5623.4	51.87	-16.33	68.2	39.21	31.85	10.89	30.08	100	12	P	H	
		5694.6	52.38	-48.84	101.22	39.65	31.98	10.88	30.13	100	12	P	H	
		5717.6	51.91	-58.22	110.13	39.19	32	10.87	30.15	100	12	P	H	
		5724	53.53	-66.39	119.92	40.81	32	10.87	30.15	100	12	P	H	
	*	5745	114.12	-	-	101.43	32	10.86	30.17	100	12	P	H	
	*	5745	104.51	-	-	91.82	32	10.86	30.17	100	12	A	H	
														H
														H
			5630	51.71	-16.49	68.2	39.06	31.84	10.89	30.08	288	145	P	V
			5691.8	51.76	-47.39	99.15	39.04	31.97	10.88	30.13	288	145	P	V
			5715	57.41	-51.99	109.4	44.68	32	10.87	30.14	288	145	P	V
			5724.6	56.63	-64.66	121.29	43.91	32	10.87	30.15	288	145	P	V
		*	5745	112.92	-	-	100.23	32	10.86	30.17	288	145	P	V
		*	5745	102.06	-	-	89.37	32	10.86	30.17	288	145	A	V
														V
													V	



WIFI Ant. 0+1	Note	Frequency (MHz)	Level (dBμV/m)	Over Limit (dB)	Limit Line (dBμV/m)	Read Level (dBμV)	Antenna Factor (dB/m)	Path Loss (dB)	Preamp Factor (dB)	Ant Pos (cm)	Table Pos (deg)	Peak Avg. (P/A)	Pol. (H/V)	
802.11ax HE20 Partial 106/54 CH 165 5825MHz	*	5825	113.63	-	-	100.74	32.2	10.91	30.22	100	45	P	H	
	*	5825	102.39	-	-	89.5	32.2	10.91	30.22	100	45	A	H	
		5851.6	50.69	-67.86	118.55	37.74	32.21	10.98	30.24	100	45	P	H	
		5873.2	52.13	-53.57	105.7	39.07	32.29	11.03	30.26	100	45	P	H	
		5878.8	52.82	-49.56	102.38	39.71	32.32	11.05	30.26	100	45	P	H	
		5936.8	52.5	-15.7	68.2	39.14	32.47	11.19	30.3	100	45	P	H	
														H
														H
	*	5825	110.91	-	-	98.02	32.2	10.91	30.22	294	206	P	V	
	*	5825	99.92	-	-	87.03	32.2	10.91	30.22	294	206	A	V	
		5852.6	53.96	-62.31	116.27	41.01	32.21	10.98	30.24	294	206	P	V	
		5857.6	51.72	-58.35	110.07	38.74	32.23	11	30.25	294	206	P	V	
		5896	52.72	-36.9	89.62	39.53	32.38	11.09	30.28	294	206	P	V	
		5930.2	51.87	-16.33	68.2	38.53	32.46	11.18	30.3	294	206	P	V	
														V
													V	
Remark	1. No other spurious found. 2. All results are PASS against Peak and Average limit line.													



Band 4 5725~5850MHz
WIFI 802.11ax HE40_Full (Band Edge @ 3m)

WIFI Ant. 0+1	Note	Frequency (MHz)	Level (dBμV/m)	Over Limit (dB)	Limit Line (dBμV/m)	Read Level (dBμV)	Antenna Factor (dB/m)	Path Loss (dB)	Preamp Factor (dB)	Ant Pos (cm)	Table Pos (deg)	Peak Avg. (P/A)	Pol. (H/V)
		5609.2	52.29	-15.91	68.2	40.02	31.88	10.89	30.5	100	9	P	H
		5669.2	51.71	-30.74	82.45	39.48	31.88	10.88	30.53	100	9	P	H
		5717.6	56.9	-53.23	110.13	44.59	32	10.87	30.56	100	9	P	H
		5723	57.92	-59.72	117.64	45.62	32	10.87	30.57	100	9	P	H
	*	5755	108.43	-	-	96.14	32.02	10.86	30.59	100	9	P	H
	*	5755	98.1	-	-	85.81	32.02	10.86	30.59	100	9	A	H
		5854.8	52.49	-58.77	111.26	39.93	32.22	10.99	30.65	100	9	P	H
		5862.6	52.25	-56.42	108.67	39.64	32.25	11.01	30.65	100	9	P	H
		5904.4	53.05	-30.36	83.41	40.21	32.41	11.11	30.68	100	9	P	H
		5949	52.63	-15.57	68.2	39.62	32.5	11.22	30.71	100	9	P	H
802.11ax													H
HE40 Full													H
CH 151		5602.6	52.42	-15.78	68.2	40.12	31.89	10.9	30.49	390	143	P	V
5755MHz		5692.4	51.49	-48.11	99.6	39.19	31.97	10.88	30.55	390	143	P	V
		5719.6	55.88	-54.81	110.69	43.58	32	10.87	30.57	390	143	P	V
		5721	54.99	-58.09	113.08	42.69	32	10.87	30.57	390	143	P	V
	*	5755	106.19	-	-	93.9	32.02	10.86	30.59	390	143	P	V
	*	5755	95.4	-	-	83.11	32.02	10.86	30.59	390	143	A	V
		5853	50.73	-64.63	115.36	38.19	32.21	10.98	30.65	390	143	P	V
		5864.6	51.15	-56.96	108.11	38.54	32.26	11.01	30.66	390	143	P	V
		5911.2	52.8	-25.58	78.38	39.93	32.42	11.13	30.68	390	143	P	V
		5936.2	52.6	-15.6	68.2	39.64	32.47	11.19	30.7	390	143	P	V
													V
													V



WIFI Ant. 0+1	Note	Frequency (MHz)	Level (dBμV/m)	Over Limit (dB)	Limit Line (dBμV/m)	Read Level (dBμV)	Antenna Factor (dB/m)	Path Loss (dB)	Preamp Factor (dB)	Ant Pos (cm)	Table Pos (deg)	Peak Avg. (P/A)	Pol. (H/V)
		5623.4	52.52	-15.68	68.2	39.86	31.85	10.89	30.08	100	7	P	H
		5683.4	53.34	-39.61	92.95	40.65	31.93	10.88	30.12	100	7	P	H
		5704.8	52.85	-53.7	106.55	40.12	32	10.87	30.14	100	7	P	H
		5720.6	51.77	-60.4	112.17	39.05	32	10.87	30.15	100	7	P	H
	*	5795	110.52	-	-	97.69	32.18	10.85	30.2	100	7	P	H
	*	5795	99.44	-	-	86.61	32.18	10.85	30.2	100	7	A	H
		5850.4	53.4	-67.89	121.29	40.46	32.2	10.98	30.24	100	7	P	H
		5860	53.71	-55.69	109.4	40.72	32.24	11	30.25	100	7	P	H
		5878.6	53.22	-49.31	102.53	40.12	32.31	11.05	30.26	100	7	P	H
		5932.8	52.43	-15.77	68.2	39.08	32.47	11.18	30.3	100	7	P	H
802.11ax													H
HE40 Full													H
CH 159		5608.6	52.31	-15.89	68.2	39.6	31.88	10.9	30.07	345	143	P	V
5795MHz		5655.8	52.72	-19.79	72.51	40.12	31.82	10.88	30.1	345	143	P	V
		5706.8	52.72	-54.39	107.11	39.99	32	10.87	30.14	345	143	P	V
		5724.4	52.5	-68.33	120.83	39.78	32	10.87	30.15	345	143	P	V
	*	5795	96.36	-	-	83.53	32.18	10.85	30.2	345	143	P	V
	*	5795	96.36	-	-	83.53	32.18	10.85	30.2	345	143	A	V
		5853.2	53.22	-61.68	114.9	40.27	32.21	10.98	30.24	345	143	P	V
		5872.2	53.61	-52.37	105.98	40.55	32.29	11.03	30.26	345	143	P	V
		5890.6	53.07	-40.55	93.62	39.9	32.36	11.08	30.27	345	143	P	V
		5940.8	52.56	-15.64	68.2	39.19	32.48	11.2	30.31	345	143	P	V
													V
													V
Remark	<ol style="list-style-type: none"> No other spurious found. All results are PASS against Peak and Average limit line. 												



Band 4 5725~5850MHz
WIFI 802.11ax HE40_Full (Harmonic @ 3m)

WIFI Ant. 0+1	Note	Frequency (MHz)	Level (dBμV/m)	Over Limit (dB)	Limit Line (dBμV/m)	Read Level (dBμV)	Antenna Factor (dB/m)	Path Loss (dB)	Preamp Factor (dB)	Ant Pos (cm)	Table Pos (deg)	Peak Avg. (P/A)	Pol. (H/V)	
802.11ax HE40 Full CH 151 5755MHz		11510	47.8	-26.2	74	53.33	40.47	14.91	60.91	100	0	P	H	
		17265	50.61	-17.59	68.2	49.33	41.06	19	58.78	100	0	P	H	
													H	
													H	
			11510	48.43	-25.57	74	53.96	40.47	14.91	60.91	100	0	P	V
			17265	50.76	-17.44	68.2	49.48	41.06	19	58.78	100	0	P	V
														V
802.11ax HE40 Full CH 159 5795MHz		11590	49.43	-24.57	74	55.21	40.23	15	61.01	100	0	P	H	
		17385	53.01	-15.19	68.2	50.46	42.05	19.14	58.64	100	0	P	H	
													H	
													H	
			11590	48.98	-25.02	74	54.76	40.23	15	61.01	100	0	P	V
			17385	51.74	-16.46	68.2	49.19	42.05	19.14	58.64	100	0	P	V
														V
Remark	1. No other spurious found.													
	2. All results are PASS against Peak and Average limit line.													



Band 4 5725~5850MHz
WIFI 802.11ax HE40_Partial 242 (Band Edge @ 3m)

WIFI Ant. 0+1	Note	Frequency (MHz)	Level (dBμV/m)	Over Limit (dB)	Limit Line (dBμV/m)	Read Level (dBμV)	Antenna Factor (dB/m)	Path Loss (dB)	Preamp Factor (dB)	Ant Pos (cm)	Table Pos (deg)	Peak Avg. (P/A)	Pol. (H/V)
		5608.4	52.37	-15.83	68.2	39.66	31.88	10.9	30.07	100	7	P	H
		5686.4	55.27	-39.9	95.17	42.56	31.95	10.88	30.12	100	7	P	H
		5719.8	77.23	-33.51	110.74	64.51	32	10.87	30.15	100	7	P	H
		5723.6	73.56	-45.45	119.01	60.84	32	10.87	30.15	100	7	P	H
	*	5755	110.36	-	-	97.65	32.02	10.86	30.17	100	7	P	H
	*	5755	99.67	-	-	86.96	32.02	10.86	30.17	100	7	A	H
		5853.4	51.34	-63.11	114.45	38.39	32.21	10.98	30.24	100	7	P	H
		5868.4	52.5	-54.55	107.05	39.47	32.27	11.02	30.26	100	7	P	H
		5915.2	53.03	-22.4	75.43	39.75	32.43	11.14	30.29	100	7	P	H
		5940.6	52.34	-15.86	68.2	38.97	32.48	11.2	30.31	100	7	P	H
802.11ax													H
HE40													H
Partial													H
262/61		5623.4	51.75	-16.45	68.2	39.09	31.85	10.89	30.08	305	144	P	V
CH 151		5694.8	51.92	-49.45	101.37	39.19	31.98	10.88	30.13	305	144	P	V
5755MHz		5709.6	57.23	-50.66	107.89	44.5	32	10.87	30.14	305	144	P	V
		5724.6	59.1	-62.19	121.29	46.38	32	10.87	30.15	305	144	P	V
	*	5755	107.74	-	-	95.03	32.02	10.86	30.17	305	144	P	V
	*	5755	97.23	-	-	84.52	32.02	10.86	30.17	305	144	A	V
		5850.6	51	-69.83	120.83	38.06	32.2	10.98	30.24	305	144	P	V
		5867.8	52.31	-54.9	107.21	39.27	32.27	11.02	30.25	305	144	P	V
		5907.2	53.5	-27.84	81.34	40.25	32.41	11.12	30.28	305	144	P	V
		5929.4	52.21	-15.99	68.2	38.87	32.46	11.18	30.3	305	144	P	V
													V
													V



WiFi Ant. 0+1	Note	Frequency (MHz)	Level (dBµV/m)	Over Limit (dB)	Limit Line (dBµV/m)	Read Level (dBµV)	Antenna Factor (dB/m)	Path Loss (dB)	Preamp Factor (dB)	Ant Pos (cm)	Table Pos (deg)	Peak Avg. (P/A)	Pol. (H/V)	
802.11ax HE40 Partial 262/62 CH 159 5795MHz		5607.4	52.57	-15.63	68.2	39.85	31.89	10.9	30.07	100	8	P	H	
		5690.2	52.78	-45.19	97.97	40.07	31.96	10.88	30.13	100	8	P	H	
		5716.8	52.29	-57.62	109.91	39.57	32	10.87	30.15	100	8	P	H	
		5724	50.72	-69.2	119.92	38	32	10.87	30.15	100	8	P	H	
	*	5795	110.66	-	-	97.83	32.18	10.85	30.2	100	8	P	H	
	*	5795	100.35	-	-	87.52	32.18	10.85	30.2	100	8	A	H	
		5850.2	61.79	-59.95	121.74	48.85	32.2	10.98	30.24	100	8	P	H	
		5870.4	52.34	-54.15	106.49	39.29	32.28	11.03	30.26	100	8	P	H	
		5885.6	58.64	-38.69	97.33	45.5	32.34	11.07	30.27	100	8	P	H	
		5948.6	52.62	-15.58	68.2	39.21	32.5	11.22	30.31	100	8	P	H	
														H
														H
			5604	51.92	-16.28	68.2	39.19	31.89	10.9	30.06	366	147	P	V
			5655.2	51.62	-20.44	72.06	39.02	31.82	10.88	30.1	366	147	P	V
			5719.8	51.72	-59.02	110.74	39	32	10.87	30.15	366	147	P	V
			5723.6	50.83	-68.18	119.01	38.11	32	10.87	30.15	366	147	P	V
	*		5795	109	-	-	96.17	32.18	10.85	30.2	366	147	P	V
	*		5795	98.32	-	-	85.49	32.18	10.85	30.2	366	147	A	V
			5853.6	59.24	-54.75	113.99	46.28	32.21	10.99	30.24	366	147	P	V
			5858.8	52.43	-57.3	109.73	39.44	32.24	11	30.25	366	147	P	V
		5912.4	52.47	-25.02	77.49	39.21	32.42	11.13	30.29	366	147	P	V	
		5946.2	51.83	-16.37	68.2	38.43	32.49	11.22	30.31	366	147	P	V	
													V	
													V	
Remark	<ol style="list-style-type: none"> No other spurious found. All results are PASS against Peak and Average limit line. 													



Band 4 5725~5850MHz
WIFI 802.11ax HE80_Full (Band Edge @ 3m)

WIFI Ant. 0+1	Note	Frequency (MHz)	Level (dBμV/m)	Over Limit (dB)	Limit Line (dBμV/m)	Read Level (dBμV)	Antenna Factor (dB/m)	Path Loss (dB)	Preamp Factor (dB)	Ant Pos (cm)	Table Pos (deg)	Peak Avg. (P/A)	Pol. (H/V)
		5608	52.38	-15.82	68.2	39.67	31.88	10.9	30.07	100	39	P	H
		5699.2	56.57	-48.04	104.61	43.83	32	10.87	30.13	100	39	P	H
		5714.8	60.49	-48.86	109.35	47.76	32	10.87	30.14	100	39	P	H
		5722.2	59.34	-56.48	115.82	46.62	32	10.87	30.15	100	39	P	H
	*	5775	106.54	-	-	93.77	32.1	10.86	30.19	100	39	P	H
	*	5775	96.35	-	-	83.58	32.1	10.86	30.19	100	39	A	H
		5850.8	56.76	-63.62	120.38	43.82	32.2	10.98	30.24	100	39	P	H
		5870.2	57.08	-49.46	106.54	44.03	32.28	11.03	30.26	100	39	P	H
		5897.6	56	-32.44	88.44	42.79	32.39	11.1	30.28	100	39	P	H
		5946.4	52.62	-15.58	68.2	39.22	32.49	11.22	30.31	100	39	P	H
802.11ax													H
HE80 Full													H
CH 155		5634.6	52.62	-15.58	68.2	39.99	31.83	10.89	30.09	352	146	P	V
5775MHz		5699.6	56.52	-48.39	104.91	43.78	32	10.87	30.13	352	146	P	V
		5709.4	58.52	-49.31	107.83	45.79	32	10.87	30.14	352	146	P	V
		5722.6	59.15	-57.58	116.73	46.43	32	10.87	30.15	352	146	P	V
	*	5775	103.86	-	-	91.09	32.1	10.86	30.19	352	146	P	V
	*	5775	93.4	-	-	80.63	32.1	10.86	30.19	352	146	A	V
		5850.2	56.5	-65.24	121.74	43.56	32.2	10.98	30.24	352	146	P	V
		5855.6	55.42	-55.21	110.63	42.46	32.22	10.99	30.25	352	146	P	V
		5888.4	53.4	-41.85	95.25	40.25	32.35	11.07	30.27	352	146	P	V
		5929.8	52.38	-15.82	68.2	39.04	32.46	11.18	30.3	352	146	P	V
													V
													V
Remark	1. No other spurious found. 2. All results are PASS against Peak and Average limit line.												



Band 4 5725~5850MHz

WIFI 802.11ax HE80_Full (Harmonic @ 3m)

WIFI Ant. 0+1	Note	Frequency (MHz)	Level (dBμV/m)	Over Limit (dB)	Limit Line (dBμV/m)	Read Level (dBμV)	Antenna Factor (dB/m)	Path Loss (dB)	Preamp Factor (dB)	Ant Pos (cm)	Table Pos (deg)	Peak Avg. (P/A)	Pol. (H/V)	
802.11ax HE80 Full CH 155 5775MHz		11550	49.67	-24.33	74	55.32	40.35	14.96	60.96	100	0	P	H	
		17325	51.46	-16.74	68.2	49.64	41.45	19.08	58.71	100	0	P	H	
													H	
													H	
			11550	49.71	-24.29	74	55.36	40.35	14.96	60.96	100	0	P	V
			17325	51.35	-16.85	68.2	49.53	41.45	19.08	58.71	100	0	P	V
														V
														V
Remark	1. No other spurious found. 2. All results are PASS against Peak and Average limit line.													



Band 4 5725~5850MHz
WIFI 802.11ax HE80_Partial 242 (Band Edge @ 3m)

WIFI Ant. 0+1	Note	Frequency (MHz)	Level (dBμV/m)	Over Limit (dB)	Limit Line (dBμV/m)	Read Level (dBμV)	Antenna Factor (dB/m)	Path Loss (dB)	Preamp Factor (dB)	Ant Pos (cm)	Table Pos (deg)	Peak Avg. (P/A)	Pol. (H/V)
		5645.8	52.49	-15.71	68.2	39.88	31.81	10.89	30.09	100	19	P	H
		5683.4	71.03	-21.92	92.95	58.34	31.93	10.88	30.12	100	19	P	H
		5719.2	71.54	-39.04	110.58	58.82	32	10.87	30.15	100	19	P	H
		5724.2	72.02	-48.36	120.38	59.3	32	10.87	30.15	100	19	P	H
	*	5775	105.86	-	-	93.09	32.1	10.86	30.19	100	19	P	H
	*	5775	96.14	-	-	83.37	32.1	10.86	30.19	100	19	A	H
		5851	67.18	-52.74	119.92	54.24	32.2	10.98	30.24	100	19	P	H
		5859.4	69.25	-40.32	109.57	56.26	32.24	11	30.25	100	19	P	H
		5877.2	59.96	-43.61	103.57	46.87	32.31	11.04	30.26	100	19	P	H
		5944.6	52.59	-15.61	68.2	39.2	32.49	11.21	30.31	100	19	P	H
802.11ax													H
HE80													H
Partial													H
484/65		5634	52.37	-15.83	68.2	39.74	31.83	10.89	30.09	301	143	P	V
CH 155		5684.8	69.53	-24.46	93.99	56.83	31.94	10.88	30.12	301	143	P	V
5775MHz		5719.2	66.68	-43.9	110.58	53.96	32	10.87	30.15	301	143	P	V
		5724.2	70.83	-49.55	120.38	58.11	32	10.87	30.15	301	143	P	V
	*	5775	104.88	-	-	92.11	32.1	10.86	30.19	301	143	P	V
	*	5775	94.26	-	-	81.49	32.1	10.86	30.19	301	143	A	V
		5854.2	62.05	-50.57	112.62	49.09	32.22	10.99	30.25	301	143	P	V
		5864.6	66.18	-41.93	108.11	53.16	32.26	11.01	30.25	301	143	P	V
		5875	58.77	-46.43	105.2	45.69	32.3	11.04	30.26	301	143	P	V
		5934.8	52.6	-15.6	68.2	39.24	32.47	11.19	30.3	301	143	P	V
													V
													V
Remark	1. No other spurious found. 2. All results are PASS against Peak and Average limit line.												



WiFi Ant. 0+1	Note	Frequency (MHz)	Level (dBμV/m)	Over Limit (dB)	Limit Line (dBμV/m)	Read Level (dBμV)	Antenna Factor (dB/m)	Path Loss (dB)	Preamp Factor (dB)	Ant Pos (cm)	Table Pos (deg)	Peak Avg. (P/A)	Pol. (H/V)	
802.11ax HE80 Partial 484/66 CH 155 5775MHz		5603.4	52.06	-16.14	68.2	39.33	31.89	10.9	30.06	100	35	P	H	
		5681.6	69.65	-21.97	91.62	56.96	31.93	10.88	30.12	100	35	P	H	
		5718.4	71.53	-38.82	110.35	58.81	32	10.87	30.15	100	35	P	H	
		5721.6	71.73	-42.72	114.45	59.01	32	10.87	30.15	100	35	P	H	
	*	5775	104.96	-	-	92.19	32.1	10.86	30.19	100	35	P	H	
	*	5775	94.76	-	-	81.99	32.1	10.86	30.19	100	35	A	H	
		5854.8	68.91	-42.35	111.26	55.95	32.22	10.99	30.25	100	35	P	H	
		5859.6	69.89	-39.62	109.51	56.9	32.24	11	30.25	100	35	P	H	
		5877.2	60.01	-43.56	103.57	46.92	32.31	11.04	30.26	100	35	P	H	
		5942.4	52.49	-15.71	68.2	39.11	32.48	11.21	30.31	100	35	P	H	
														H
														H
			5630	52.26	-15.94	68.2	39.61	31.84	10.89	30.08	298	144	P	V
			5685.2	69.68	-24.6	94.28	56.98	31.94	10.88	30.12	298	144	P	V
			5719.8	66.93	-43.81	110.74	54.21	32	10.87	30.15	298	144	P	V
			5723	69.52	-48.12	117.64	56.8	32	10.87	30.15	298	144	P	V
	*		5775	104.1	-	-	91.33	32.1	10.86	30.19	298	144	P	V
	*		5775	93.96	-	-	81.19	32.1	10.86	30.19	298	144	A	V
			5851.4	62.99	-56.02	119.01	50.04	32.21	10.98	30.24	298	144	P	V
			5864.8	65.47	-42.58	108.05	52.45	32.26	11.01	30.25	298	144	P	V
		5876.2	57.53	-46.78	104.31	44.45	32.3	11.04	30.26	298	144	P	V	
		5940.8	52.25	-15.95	68.2	38.88	32.48	11.2	30.31	298	144	P	V	
													V	
													V	
Remark	1. No other spurious found. 2. All results are PASS against Peak and Average limit line.													



Emission below 1GHz
WIFI 802.11ax HE40 Full (LF @ 3m)

WIFI	Note	Frequency	Level	Over	Limit	Read	Antenna	Path	Preamp	Ant	Table	Peak	Pol.	
Ant.				Limit	Line	Level	Factor	Loss	Factor	Pos	Pos	Avg.		
0+1		(MHz)	(dBμV/m)	(dB)	(dBμV/m)	(dBμV)	(dB/m)	(dB)	(dB)	(cm)	(deg)	(P/A)	(H/V)	
802.11ax HE40 Full LF		79.47	24.27	-15.73	40	42.02	13.57	1.2	32.52	-	-	P	H	
		110.51	24.11	-19.39	43.5	37.96	17.06	1.44	32.35	-	-	P	H	
		157.07	22.99	-20.51	43.5	36.81	16.88	1.73	32.43	-	-	P	H	
		206.54	33.1	-10.4	43.5	48.54	14.89	2.05	32.38	-	-	P	H	
		305.48	25.21	-20.79	46	36.18	19.14	2.4	32.51	-	-	P	H	
		889.42	35.95	-10.05	46	35.12	28.49	4.26	31.92	100	0	P	H	
														H
														H
														H
														H
														H
														H
			38.73	24.04	-15.96	40	35.58	20	0.8	32.34	-	-	P	V
			79.47	22.34	-17.66	40	40.09	13.57	1.2	32.52	-	-	P	V
			107.6	22.88	-20.62	43.5	36.96	16.84	1.41	32.33	-	-	P	V
			207.51	27.94	-15.56	43.5	43.39	14.88	2.05	32.38	-	-	P	V
			568.35	27.33	-18.67	46	30.62	25.83	3.3	32.42	-	-	P	V
			889.42	35.17	-10.83	46	34.34	28.49	4.26	31.92	100	0	P	V
														V
														V
													V	
													V	
													V	
													V	
Remark	1. No other spurious found. 2. All results are PASS against limit line.													



Note symbol

*	Fundamental Frequency which can be ignored. However, the level of any unwanted emissions shall not exceed the level of the fundamental frequency.
!	Test result is over limit line.
P/A	Peak or Average
H/V	Horizontal or Vertical



A calculation example for radiated spurious emission is shown as below:

WIFI	Note	Frequency	Level	Over	Limit	Read	Antenna	Path	Preamp	Ant	Table	Peak	Pol.
Ant.				Limit	Line	Level	Factor	Loss	Factor	Pos	Pos	Avg.	
0+1		(MHz)	(dBμV/m)	(dB)	(dBμV/m)	(dBμV)	(dB/m)	(dB)	(dB)	(cm)	(deg)	(P/A)	(H/V)
802.11b		2390	55.45	-18.55	74	54.51	32.22	4.58	35.86	103	308	P	H
CH 01													
2412MHz		2390	43.54	-10.46	54	42.6	32.22	4.58	35.86	103	308	A	H

1. Path Loss(dB) = Cable loss(dB) + Filter loss(dB) + Attenuator loss(dB)
2. Level(dBμV/m) = Antenna Factor(dB/m) + Path Loss(dB) + Read Level(dBμV) - Preamp Factor(dB)
3. Over Limit(dB) = Level(dBμV/m) – Limit Line(dBμV/m)

For Peak Limit @ 2390MHz:

1. Level(dBμV/m)
= Antenna Factor(dB/m) + Path Loss(dB) + Read Level(dBμV) - Preamp Factor(dB)
= 32.22(dB/m) + 4.58(dB) + 54.51(dBμV) – 35.86 (dB)
= 55.45 (dBμV/m)
2. Over Limit(dB)
= Level(dBμV/m) – Limit Line(dBμV/m)
= 55.45(dBμV/m) – 74(dBμV/m)
= -18.55(dB)

For Average Limit @ 2390MHz:

1. Level(dBμV/m)
= Antenna Factor(dB/m) + Path Loss(dB) + Read Level(dBμV) - Preamp Factor(dB)
= 32.22(dB/m) + 4.58(dB) + 42.6(dBμV) – 35.86 (dB)
= 43.54 (dBμV/m)
2. Over Limit(dB) = Level(dBμV/m) – Limit Line(dBμV/m)
= 43.54(dBμV/m) – 54(dBμV/m)
= -10.46(dB)

Both peak and average measured complies with the limit line, so test result is “PASS”.



Appendix D. Radiated Spurious Emission Plots

Test Engineer :	Leo Lee, Mancy Chou, and Bigshow Wang	Temperature :	22.1~24.0°C
		Relative Humidity :	45~59%

Note symbol

-L	Low channel location
-R	High channel location



Band 4 - 5725~5850MHz
WIFI 802.11a (Band Edge @ 3m)

WIFI	Band 4 5725~5850MHz Band Edge @ 3m	
ANT	802.11a CH149 5745MHz	
0+1	Horizontal	Fundamental
Peak	<p> Site : 03CH15-1FY Condition : PEAK_BE(84)_16-24 3m 91200_15_1620 HORIZONTAL Detector : RBW:1000.000KHz VBW:3000.000KHz SWT:Auto Project : Peak : 041657 </p>	<p> Site : 03CH15-1FY Condition : PEAK(LINII) 3m 91200_15_1620 HORIZONTAL Detector : RBW:1000.000KHz VBW:3000.000KHz SWT:Auto Project : Peak : 041657 </p>

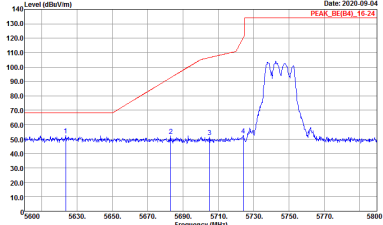
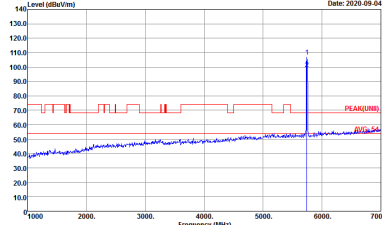

WIFI	Band 4 5725~5850MHz Band Edge @ 3m	
ANT	802.11a CH149 5745MHz	
0+1	Vertical	Fundamental
Peak	 <p>Date: 2020-09-04 PEAK: 8E(84)_16-24</p> <p>Site : 03CH15-HY Condition : PEAK_8E(84)_16-24 3m 91200_15_1620 VERTICAL RBW:1000.000KHz VBW:3000.000KHz SWT:Auto Detector : Peak Project : 041657</p>	 <p>Date: 2020-09-04 PEAK: UN(II)</p> <p>Site : 03CH15-HY Condition : PEAK(UNII) 3m 91200_15_1620 VERTICAL RBW:1000.000KHz VBW:3000.000KHz SWT:Auto Detector : Peak Project : 041657</p>



WIFI	Band 4 5725~5850MHz Band Edge @ 3m	
ANT	802.11a CH157 5785MHz	
0+1	Horizontal	Fundamental
<p>Peak</p>	<p>Date: 2020-09-04 PEAK_BE(84)_16-24</p> <p>Site : 03CH15-HY Condition : PEAK_BE(84)_16-24 3m 91200_15_1620 HORIZONTAL RBW:1000.000KHz VBW:3000.000KHz SWT:Auto Detector : Peak Project : 041657</p>	<p>Date: 2020-09-04 PEAK_UN(84)_16-24</p> <p>Site : 03CH15-HY Condition : PEAK_UN(84)_16-24 3m 91200_15_1620 HORIZONTAL RBW:1000.000KHz VBW:3000.000KHz SWT:Auto Detector : Peak Project : 041657</p>
<p>Peak</p>	<p>Date: 2020-09-04 PEAK_BE(84)_16-24</p> <p>Site : 03CH15-HY Condition : PEAK_BE(84)_16-24 3m 91200_15_1620 HORIZONTAL RBW:1000.000KHz VBW:3000.000KHz SWT:Auto Detector : Peak Project : 041657</p>	<p>Left blank</p>



WIFI	Band 4 5725~5850MHz Band Edge @ 3m	
ANT	802.11a CH157 5785MHz	
0+1	Vertical	Fundamental
Peak	<p>Site : 03CH15-HY Condition : PEAK_BE(B4)_16-24 3m 91200_15_1620 VERTICAL Detector : Peak Project : 041657</p>	<p>Site : 03CH15-HY Condition : PEAK(UNII) 3m 91200_15_1620 VERTICAL Detector : Peak Project : 041657</p>
Peak	<p>Site : 03CH15-HY Condition : PEAK_BE(B4)_16-24 3m 91200_15_1620 VERTICAL Detector : Peak Project : 041657</p>	Left blank

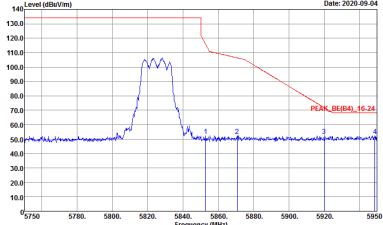
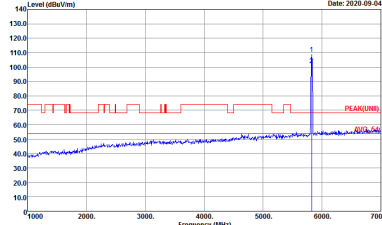

WIFI	Band 4 5725~5850MHz Band Edge @ 3m	
ANT	802.11a CH165 5825MHz	
0+1	Horizontal	Fundamental
Peak	 <p>Site : 03CH15-HY Condition : PEAK_BE(B4)_16-24 3m 91200_15_1620 HORIZONTAL RBW:1000.000KHz VBW:3000.000KHz SWT:Auto Detector : Peak Project : 041657</p>	 <p>Site : 03CH15-HY Condition : PEAK(UNII) 3m 91200_15_1620 HORIZONTAL RBW:1000.000KHz VBW:3000.000KHz SWT:Auto Detector : Peak Project : 041657</p>



WIFI	Band 4 5725~5850MHz Band Edge @ 3m	
ANT	802.11a CH165 5825MHz	
0+1	Vertical	Fundamental
Peak	<p>Site : 03CH15-HY Condition : PEAK_BE(B4)_16-24 3m 91200_15_1620 VERTICAL RBW:1000.000KHz VBW:3000.000KHz SWT:Auto Detector : Peak Project : 041657</p>	<p>Site : 03CH15-HY Condition : PEAK(UNII) 3m 91200_15_1620 VERTICAL RBW:1000.000KHz VBW:3000.000KHz SWT:Auto Detector : Peak Project : 041657</p>



Band 4 5725~5850MHz
WIFI 802.11ax HE20 Full (Band Edge @ 3m)

WIFI	Band 4 5725~5850MHz Band Edge @ 3m	
ANT	802.11ax HE20 Full CH149 5745MHz	
0+1	Horizontal	Fundamental
Peak	<p>Site : 03CH15-HY Condition : PEAK_8E(B4)_16-24 3m 91200_15_1620 HORIZONTAL Detector : RBW:1000.000KHz VBW:3000.000KHz SWT:Auto Project : 041657</p>	<p>Site : 03CH15-HY Condition : PEAK(UNIT) 3m 91200_15_1620 HORIZONTAL Detector : RBW:1000.000KHz VBW:3000.000KHz SWT:Auto Project : 041657</p>

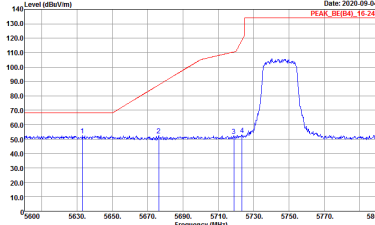
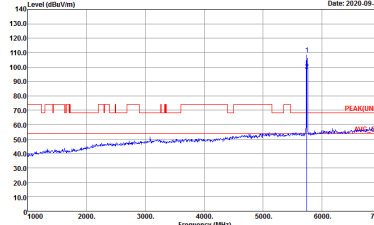

WIFI	Band 4 5725~5850MHz Band Edge @ 3m	
ANT	802.11ax HE20 Full CH149 5745MHz	
0+1	Vertical	Fundamental
Peak	 <p>Date: 2020-09-04 PEAK_BE(84)_16-24</p> <p>Site : 03CH15-HY Condition : PEAK_BE(84)_16-24 3m 91200_15_1620 VERTICAL RBW:1000.000KHz VBW:3000.000KHz SWT:Auto Detector : Peak Project : 041657</p>	 <p>Date: 2020-09-04 PEAK(UNII)_3m 91200_15_1620 VERTICAL</p> <p>Site : 03CH15-HY Condition : PEAK(UNII)_3m 91200_15_1620 VERTICAL RBW:1000.000KHz VBW:3000.000KHz SWT:Auto Detector : Peak Project : 041657</p>



WIFI	Band 4 5725~5850MHz Band Edge @ 3m	
ANT	802.11ax HE20 Full CH157 5785MHz	
0+1	Horizontal	Fundamental
Peak	<p>Site : 03CH15-HY Condition : PEAK_BE(84)_16-24 3m 91200_15_1620 HORIZONTAL Detector : Peak Project : 041657</p>	<p>Site : 03CH15-HY Condition : PEAK(UNII) 3m 91200_15_1620 HORIZONTAL Detector : Peak Project : 041657</p>
Peak	<p>Site : 03CH15-HY Condition : PEAK_BE(84)_16-24 3m 91200_15_1620 HORIZONTAL Detector : Peak Project : 041657</p>	Left blank



WIFI	Band 4 5725~5850MHz Band Edge @ 3m	
ANT	802.11ax HE20 Full CH157 5785MHz	
0+1	Vertical	Fundamental
Peak	<p>Site : 03CH15-HY Condition : PEAK_BE(84)_16-24 3m 91200_15_1620 VERTICAL RBW:1000.000KHz VBW:3000.000KHz SWT:Auto Detector : Peak Project : 041657</p>	<p>Site : 03CH15-HY Condition : PEAK(UNII) 3m 91200_15_1620 VERTICAL RBW:1000.000KHz VBW:3000.000KHz SWT:Auto Detector : Peak Project : 041657</p>
Peak	<p>Site : 03CH15-HY Condition : PEAK_BE(84)_16-24 3m 91200_15_1620 VERTICAL RBW:1000.000KHz VBW:3000.000KHz SWT:Auto Detector : Peak Project : 041657</p>	Left blank

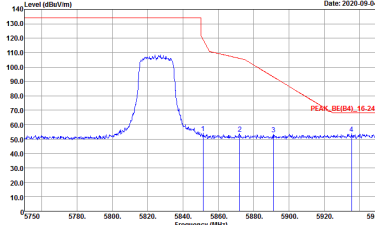
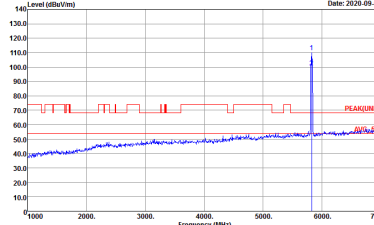

WIFI	Band 4 5725~5850MHz Band Edge @ 3m	
ANT	802.11ax HE20 Full CH165 5825MHz	
0+1	Horizontal	Fundamental
Peak	 <p>Site : 03CH15-HY Condition : PEAK_BE(B4)_16-24 3m 91200_15_1620 HORIZONTAL RBW:1000.000KHz VBW:3000.000KHz SWT:Auto Detector : Peak Project : 041657</p>	 <p>Site : 03CH15-HY Condition : PEAK(UWB) 3m 91200_15_1620 HORIZONTAL RBW:1000.000KHz VBW:3000.000KHz SWT:Auto Detector : Peak Project : 041657</p>

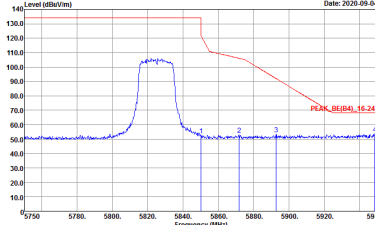
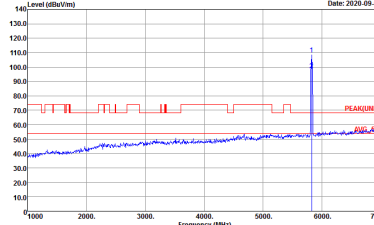

WIFI	Band 4 5725~5850MHz Band Edge @ 3m	
ANT	802.11ax HE20 Full CH165 5825MHz	
0+1	Vertical	Fundamental
Peak	 <p>Site : 03CH15-HY Condition : PEAK_BE(84)_16-24 3m 91200_15_1620 VERTICAL RBW:1000.000KHz VBW:3000.000KHz SWT:Auto Detector : Peak Project : 041657</p>	 <p>Site : 03CH15-HY Condition : PEAK(UNII) 3m 91200_15_1620 VERTICAL RBW:1000.000KHz VBW:3000.000KHz SWT:Auto Detector : Peak Project : 041657</p>



Band 4 5725~5850MHz
WIFI 802.11ax HE20 Partial 26 (Band Edge @ 3m)

WIFI	Band 4 5725~5850MHz Band Edge @ 3m	
ANT	802.11ax HE20 Partial 26/0 CH149 5745MHz	
0+1	Horizontal	Fundamental
Peak	<p>Site : 03CH15-HY Condition : PEAK_BE(84)_16-24 3m 91200_15_1620 HORIZONTAL Detector : RBW:1000.000KHz VBW:3000.000KHz SWT:Auto Project : 041657</p>	<p>Site : 03CH15-HY Condition : PEAK(UNIT) 3m 91200_15_1620 HORIZONTAL Detector : RBW:1000.000KHz VBW:3000.000KHz SWT:Auto Project : 041657</p>

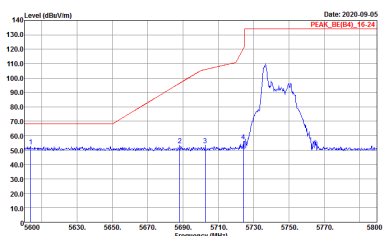
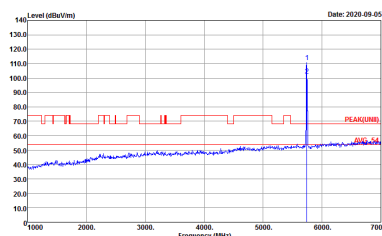

WIFI	Band 4 5725~5850MHz Band Edge @ 3m	
ANT	802.11ax HE20 Partial 26/0 CH149 5745MHz	
0+1	Vertical	Fundamental
Peak	 <p>Date: 2020-09-05 PEAK: 8E(84)_16-24</p> <p>Site : 03CH15-HY Condition : PEAK_8E(84)_16-24 3m 91200_15_1620 VERTICAL RBW:1000.000KHz VBW:3000.000KHz SWT:Auto Detector : Peak Project : 041657</p>	 <p>Date: 2020-09-05 PEAK: UN(8)</p> <p>Site : 03CH15-HY Condition : PEAK(UNII) 3m 91200_15_1620 VERTICAL RBW:1000.000KHz VBW:3000.000KHz SWT:Auto Detector : Peak Project : 041657</p>

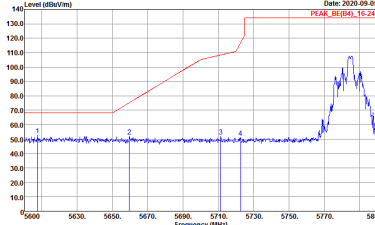
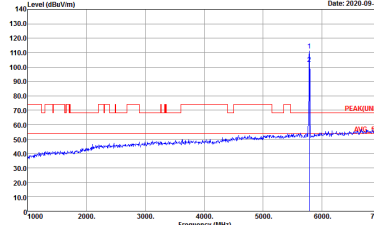
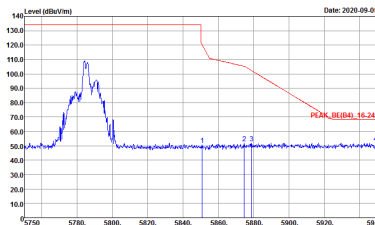

WIFI	Band 4 5725~5850MHz Band Edge @ 3m	
ANT	802.11ax HE20 Partial 26/4 CH157 5785MHz	
0+1	Horizontal	Fundamental
<p>Peak</p>	 <p>Date: 2020-09-05 PEAK_BE(84)_16-24</p> <p>Site : 03CH15-HY Condition : PEAK_BE(84)_16-24 3m 91200_15_1620 HORIZONTAL RBW:1000.000KHz VBW:3000.000KHz SWT:Auto Detector : Peak Project : 041657</p>	 <p>Date: 2020-09-05 PEAK(URB)</p> <p>Site : 03CH15-HY Condition : PEAK(UNII) 3m 91200_15_1620 HORIZONTAL RBW:1000.000KHz VBW:3000.000KHz SWT:Auto Detector : Peak Project : 041657</p>
<p>Peak</p>	 <p>Date: 2020-09-05 PEAK_BE(84)_16-24</p> <p>Site : 03CH15-HY Condition : PEAK_BE(84)_16-24 3m 91200_15_1620 HORIZONTAL RBW:1000.000KHz VBW:3000.000KHz SWT:Auto Detector : Peak Project : 041657</p>	<p>Left blank</p>



WIFI	Band 4 5725~5850MHz Band Edge @ 3m	
ANT	802.11ax HE20 Partial 26/4 CH157 5785MHz	
0+1	Vertical	Fundamental
Peak	<p>Site : 03CH15-HY Condition : PEAK_BE(B4)_16-24 3m 91200_15_1620 VERTICAL : RBW:1000.000KHz VBW:3000.000KHz SWT:Auto Detector : Peak Project : 041657</p>	<p>Site : 03CH15-HY Condition : PEAK(UNII) 3m 91200_15_1620 VERTICAL : RBW:1000.000KHz VBW:3000.000KHz SWT:Auto Detector : Peak Project : 041657</p>
Peak	<p>Site : 03CH15-HY Condition : PEAK_BE(B4)_16-24 3m 91200_15_1620 VERTICAL : RBW:1000.000KHz VBW:3000.000KHz SWT:Auto Detector : Peak Project : 041657</p>	Left blank

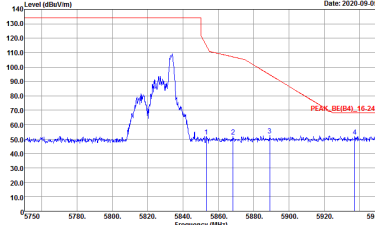
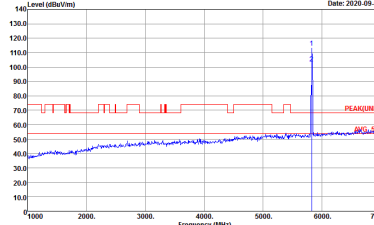

WIFI	Band 4 5725~5850MHz Band Edge @ 3m	
ANT	802.11ax HE20 Partial 26/8 CH165 5825MHz	
0+1	Horizontal	Fundamental
Peak	 <p>Site : 03CH15-HY Condition : PEAK_BE(B4)_16-24 3m 91200_15_1620 HORIZONTAL RBW:1000.000KHz VBW:3000.000KHz SWT:Auto Detector : Peak Project : 041657</p>	 <p>Site : 03CH15-HY Condition : PEAK(FB) 3m 91200_15_1620 HORIZONTAL RBW:1000.000KHz VBW:3000.000KHz SWT:Auto Detector : Peak Project : 041657</p>

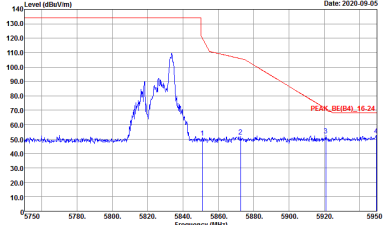
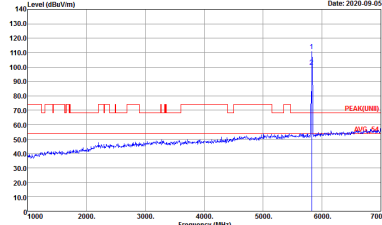

WIFI	Band 4 5725~5850MHz Band Edge @ 3m	
ANT	802.11ax HE20 Partial 26/8 CH165 5825MHz	
0+1	Vertical	Fundamental
Peak	 <p>Site : 03CH15-HY Condition : PEAK_BE(B4)_16-24 3m 91200_15_1620 VERTICAL RBW:1000.000KHz VBW:3000.000KHz SWT:Auto Detector : Peak Project : 041657</p>	 <p>Site : 03CH15-HY Condition : PEAK(UNII) 3m 91200_15_1620 VERTICAL RBW:1000.000KHz VBW:3000.000KHz SWT:Auto Detector : Peak Project : 041657</p>



Band 4 5725~5850MHz
WIFI 802.11ax HE20 Partial 52 (Band Edge @ 3m)

WIFI	Band 4 5725~5850MHz Band Edge @ 3m	
ANT	802.11ax HE20 Partial 52/37 CH149 5745MHz	
0+1	Horizontal	Fundamental
Peak	<p>Date: 2020-09-05 PEAK_BE(B4)_16-24</p> <p>Site : 03CH15-HY Condition : PEAK_BE(B4)_16-24 3m 91200_15_1620 HORIZONTAL RBW:1000.000KHz VBW:3000.000KHz SWT:Auto Detector : Peak Project : 041657</p>	<p>Date: 2020-09-05 PEAK(UNIT)_005_54</p> <p>Site : 03CH15-HY Condition : PEAK(UNIT) 3m 91200_15_1620 HORIZONTAL RBW:1000.000KHz VBW:3000.000KHz SWT:Auto Detector : Peak Project : 041657</p>

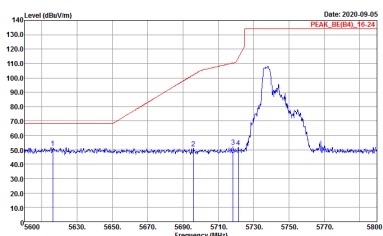
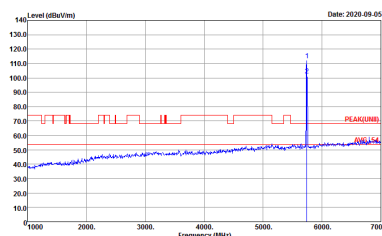

WIFI	Band 4 5725~5850MHz Band Edge @ 3m	
ANT	802.11ax HE20 Partial 52/37 CH149 5745MHz	
0+1	Vertical	Fundamental
Peak	 <p>Date: 2020-09-05 PEAK_BE(4)_16-24</p> <p>Site : 03CH15-HY Condition : PEAK_BE(4)_16-24 3m 91200_15_1620 VERTICAL RBW:1000.000KHz VBW:3000.000KHz SWT:Auto Detector : Peak Project : 041657</p>	 <p>Date: 2020-09-05 PEAK_UNI(1)</p> <p>Site : 03CH15-HY Condition : PEAK_UNI(1) 3m 91200_15_1620 VERTICAL RBW:1000.000KHz VBW:3000.000KHz SWT:Auto Detector : Peak Project : 041657</p>

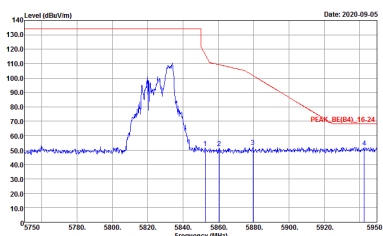
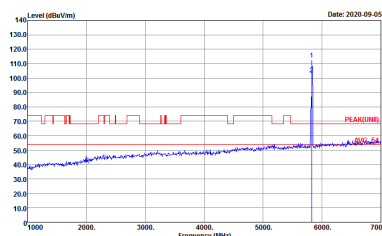

WIFI	Band 4 5725~5850MHz Band Edge @ 3m	
ANT	802.11ax HE20 Partial 52/40 CH165 5825MHz	
0+1	Horizontal	Fundamental
Peak	 <p>Site : 03CH15-HY Condition : PEAK_BE(B4)_16-24 3m 91200_15_1620 HORIZONTAL RBW:1000.000KHz VBW:3000.000KHz SWT:Auto Detector : Peak Project : 041657</p>	 <p>Site : 03CH15-HY Condition : PEAK(FB) 3m 91200_15_1620 HORIZONTAL RBW:1000.000KHz VBW:3000.000KHz SWT:Auto Detector : Peak Project : 041657</p>



WIFI	Band 4 5725~5850MHz Band Edge @ 3m	
ANT	802.11ax HE20 Partial 52/40 CH165 5825MHz	
0+1	Vertical	Fundamental
Peak	<p>Site : 03CH15-HY Condition : PEAK_BE(B4)_16-24 3m 91200_15_1620 VERTICAL RBW:1000.000KHz VBW:3000.000KHz SWT:Auto Detector : Peak Project : 041657</p>	<p>Site : 03CH15-HY Condition : PEAK(UWB) 3m 91200_15_1620 VERTICAL RBW:1000.000KHz VBW:3000.000KHz SWT:Auto Detector : Peak Project : 041657</p>



Band 4 5725~5850MHz
WIFI 802.11ax HE20 Partial 106 (Band Edge @ 3m)

Table with 2 columns: Horizontal and Fundamental. It contains two spectral plots showing Level (dBu/m) vs Frequency (MHz) with associated site and condition metadata.

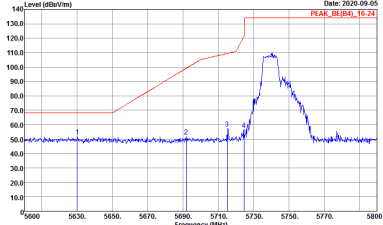
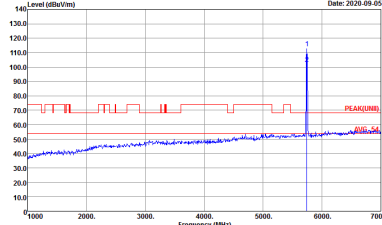

WIFI	Band 4 5725~5850MHz Band Edge @ 3m	
ANT	802.11ax HE20 Partial 106/53 CH149 5745MHz	
0+1	Vertical	Fundamental
Peak	 <p>Date: 2020-09-05 PEAK: 8E(84)_16-24</p> <p>Site : 03CH15-HY Condition : PEAK_8E(84)_16-24 3m 91200_15_1620 VERTICAL RBW:1000.000KHz VBW:3000.000KHz SWT:Auto Detector : Peak Project : 041657</p>	 <p>Date: 2020-09-05 PEAK: UN(II)</p> <p>Site : 03CH15-HY Condition : PEAK(UNII) 3m 91200_15_1620 VERTICAL RBW:1000.000KHz VBW:3000.000KHz SWT:Auto Detector : Peak Project : 041657</p>

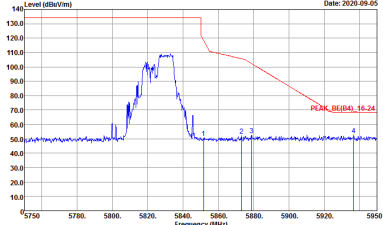
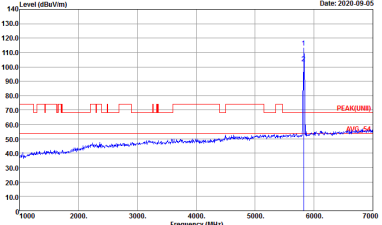

WIFI	Band 4 5725~5850MHz Band Edge @ 3m	
ANT	802.11ax HE20 Partial 106/54 CH165 5825MHz	
0+1	Horizontal	Fundamental
Peak	 <p>Date: 2020-09-05</p> <p>PEAK_BE(B4)_16-24</p> <p>Site : 03CH15-HY Condition : PEAK_BE(B4)_16-24 3m 91200_15_1620 HORIZONTAL RBW:1000.000KHz VBW:3000.000KHz SWT:Auto Detector : Peak Project : 041657</p>	 <p>Date: 2020-09-05</p> <p>PEAK(FUN)</p> <p>Site : 03CH15-HY Condition : PEAK(FUN) 3m 91200_15_1620 HORIZONTAL RBW:1000.000KHz VBW:3000.000KHz SWT:Auto Detector : Peak Project : 041657</p>

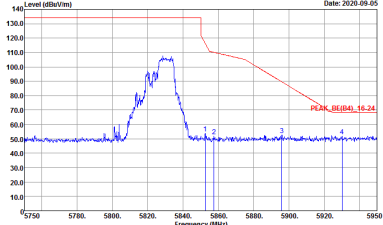
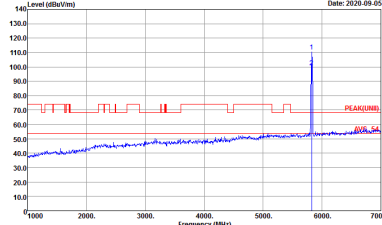

WIFI	Band 4 5725~5850MHz Band Edge @ 3m	
ANT	802.11ax HE20 Partial 106/54 CH165 5825MHz	
0+1	Vertical	Fundamental
Peak	 <p>Date: 2020-09-05</p> <p>Site : 03CH15-HY Condition : PEAK_BE(84)_16-24 3m 91200_15_1620 VERTICAL RBW:1000.000KHz VBW:3000.000KHz SWT:Auto Detector : Peak Project : 041657</p>	 <p>Date: 2020-09-05</p> <p>Site : 03CH15-HY Condition : PEAK(UNII) 3m 91200_15_1620 VERTICAL RBW:1000.000KHz VBW:3000.000KHz SWT:Auto Detector : Peak Project : 041657</p>



Band 4 5725~5850MHz
WIFI 802.11ax HE40 Full (Band Edge @ 3m)

WIFI	Band 4 5725~5850MHz Band Edge @ 3m	
ANT	802.11ax HE40 Full CH151 5755MHz	
0+1	Horizontal	Fundamental
Peak	<p>Site : 03CH15-HY Condition : PEAK_BE(B4)_16-24 3m 91200_15_1620 HORIZONTAL RBW:1000.000KHz VBW:3000.000KHz SWT:Auto Detector : Peak Project : 041657</p>	<p>Site : 03CH15-HY Condition : PEAK(UNIT) 3m 91200_15_1620 HORIZONTAL RBW:1000.000KHz VBW:3000.000KHz SWT:Auto Detector : Peak Project : 041657</p>
Peak	<p>Site : 03CH15-HY Condition : PEAK_BE(B4)_16-24 3m 91200_15_1620 HORIZONTAL RBW:1000.000KHz VBW:3000.000KHz SWT:Auto Detector : Peak Project : 041657</p>	Left blank



WIFI	Band 4 5725~5850MHz Band Edge @ 3m	
ANT	802.11ax HE40 Full CH151 5755MHz	
0+1	Vertical	Fundamental
Peak	<p>Site : 03CH15-HY Condition : PEAK_BE(84)_16-24 3m 91200_15_1620 VERTICAL Detector : Peak Project : 041657</p>	<p>Site : 03CH15-HY Condition : PEAK(UNII) 3m 91200_15_1620 VERTICAL Detector : Peak Project : 041657</p>
Peak	<p>Site : 03CH15-HY Condition : PEAK_BE(84)_16-24 3m 91200_15_1620 VERTICAL Detector : Peak Project : 041657</p>	Left blank

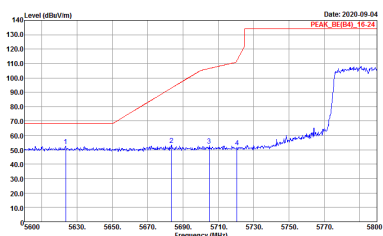
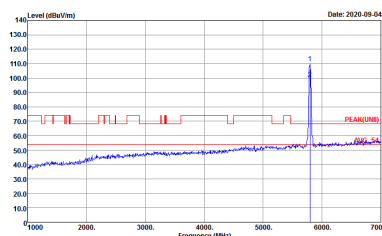
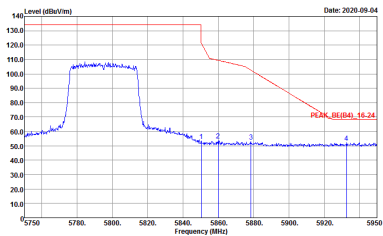

WIFI	Band 4 5725~5850MHz Band Edge @ 3m	
ANT	802.11ax HE40 Full HT40 CH159 5795MHz	
0+1	Horizontal	Fundamental
<p>Peak</p>	 <p>Site : 03CH15-HY Condition : PEAK_BE(84)_16-24 3m 91200_15_1620 HORIZONTAL Detector : Peak Project : 041657</p>	 <p>Site : 03CH15-HY Condition : PEAK(UNII) 3m 91200_15_1620 HORIZONTAL Detector : Peak Project : 041657</p>
<p>Peak</p>	 <p>Site : 03CH15-HY Condition : PEAK_BE(84)_16-24 3m 91200_15_1620 HORIZONTAL Detector : Peak Project : 041657</p>	<p>Left blank</p>



WIFI	Band 4 5725~5850MHz Band Edge @ 3m	
ANT	802.11ax HE40 Full CH159 5795MHz	
0+1	Vertical	Fundamental
Peak	<p>Site : 03CH15-HY Condition : PEAK_BE(B4)_16-24 3m 91200_15_1620 VERTICAL Detector : Peak Project : 041657</p>	<p>Site : 03CH15-HY Condition : PEAK(UNII) 3m 91200_15_1620 VERTICAL Detector : Peak Project : 041657</p>
Peak	<p>Site : 03CH15-HY Condition : PEAK_BE(B4)_16-24 3m 91200_15_1620 VERTICAL Detector : Peak Project : 041657</p>	Left blank



Band 4 5725~5850MHz
WIFI 802.11ax HE40 Partial 242 (Band Edge @ 3m)

WIFI	Band 4 5725~5850MHz Band Edge @ 3m	
ANT	802.11ax HE40 Partial 242/61 CH151 5755MHz	
0+1	Horizontal	Fundamental
Peak	<p>Site : 03CH15-HY Condition : PEAK_BE(B4)_16-24 3m 91200_15_1620 HORIZONTAL RBW:1000.000KHz VBW:3000.000KHz SWT:Auto Detector : Peak Project : 041657</p>	<p>Site : 03CH15-HY Condition : PEAK(UNIT) 3m 91200_15_1620 HORIZONTAL RBW:1000.000KHz VBW:3000.000KHz SWT:Auto Detector : Peak Project : 041657</p>
Peak	<p>Site : 03CH15-HY Condition : PEAK_BE(B4)_16-24 3m 91200_15_1620 HORIZONTAL RBW:1000.000KHz VBW:3000.000KHz SWT:Auto Detector : Peak Project : 041657</p>	Left blank



WIFI	Band 4 5725~5850MHz Band Edge @ 3m	
ANT	802.11ax HE40 Partial 242/61 CH151 5755MHz	
0+1	Vertical	Fundamental
Peak	<p>Date: 2020-09-05 PEAK_BE(84)_16-24</p> <p>Site : 03CH15-HY Condition : PEAK_BE(84)_16-24 3m 91200_15_1620 VERTICAL RBW:1000.000KHz VBW:3000.000KHz SWT:Auto Detector : Peak Project : 041657</p>	<p>Date: 2020-09-05 PEAK_UNI(84)_16-24</p> <p>Site : 03CH15-HY Condition : PEAK_UNI(84)_16-24 3m 91200_15_1620 VERTICAL RBW:1000.000KHz VBW:3000.000KHz SWT:Auto Detector : Peak Project : 041657</p>
Peak	<p>Date: 2020-09-05 PEAK_BE(84)_16-24</p> <p>Site : 03CH15-HY Condition : PEAK_BE(84)_16-24 3m 91200_15_1620 VERTICAL RBW:1000.000KHz VBW:3000.000KHz SWT:Auto Detector : Peak Project : 041657</p>	Left blank

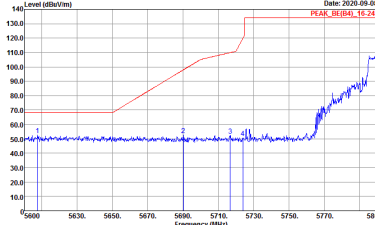
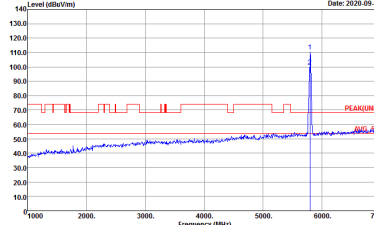
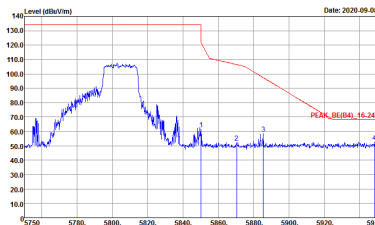

WIFI	Band 4 5725~5850MHz Band Edge @ 3m	
ANT	802.11ax HE40 Partial 242/62 CH159 5795MHz	
0+1	Horizontal	Fundamental
<p>Peak</p>	 <p>Site : 03CH15-HY Condition : PEAK_BE(B4)_16-24 3m 91200_15_1620 HORIZONTAL Detector : Peak Project : 041657</p>	 <p>Site : 03CH15-HY Condition : PEAK(UNII) 3m 91200_15_1620 HORIZONTAL Detector : Peak Project : 041657</p>
<p>Peak</p>	 <p>Site : 03CH15-HY Condition : PEAK_BE(B4)_16-24 3m 91200_15_1620 HORIZONTAL Detector : Peak Project : 041657</p>	<p>Left blank</p>

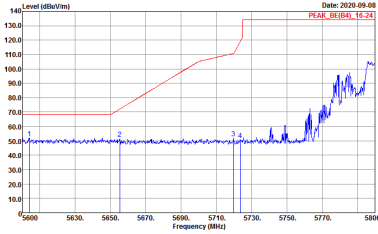
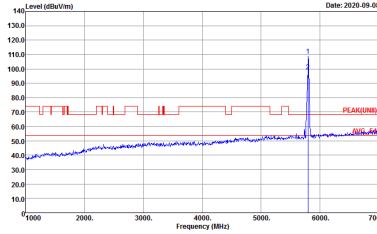
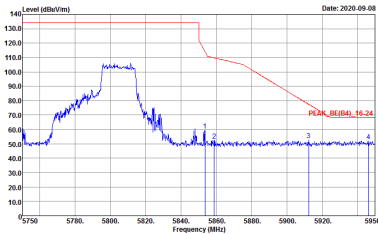

WIFI	Band 4 5725~5850MHz Band Edge @ 3m	
ANT	802.11ax HE40 Partial 242/62 CH159 5795MHz	
0+1	Vertical	Fundamental
Peak	 <p>Date: 2020-09-08 PEAK_BE(84)_16-24</p> <p>Site : 03CH15-HY Condition : PEAK_BE(84)_16-24 3m 91200_15_1620 VERTICAL Detector : Peak Project : 041657</p>	 <p>Date: 2020-09-08 PEAK(UNII)</p> <p>Site : 03CH15-HY Condition : PEAK(UNII) 3m 91200_15_1620 VERTICAL Detector : Peak Project : 041657</p>
Peak	 <p>Date: 2020-09-08 PEAK_BE(84)_16-24</p> <p>Site : 03CH15-HY Condition : PEAK_BE(84)_16-24 3m 91200_15_1620 VERTICAL Detector : Peak Project : 041657</p>	Left blank



Band 4 5725~5850MHz
WIFI 802.11ax HE80 Full (Band Edge @ 3m)

WIFI	Band 4 5725~5850MHz Band Edge @ 3m	
ANT	802.11ax HE80 Full CH155 5775MHz	
0+1	Horizontal	Fundamental
Peak	<p>Site : 03CH15-HY Condition : PEAK_BE(B4)_16-24 3m 91200_15_1620 HORIZONTAL RBW:1000.000kHz VBW:3000.000kHz SWT:Auto Detector : Peak Project : 041657</p>	<p>Site : 03CH15-HY Condition : PEAK(UNIT) 3m 91200_15_1620 HORIZONTAL RBW:1000.000kHz VBW:3000.000kHz SWT:Auto Detector : Peak Project : 041657</p>
Peak	<p>Site : 03CH15-HY Condition : PEAK_BE(B4)_16-24 3m 91200_15_1620 HORIZONTAL RBW:1000.000kHz VBW:3000.000kHz SWT:Auto Detector : Peak Project : 041657</p>	Left blank



WIFI	Band 4 5725~5850MHz Band Edge @ 3m	
ANT	802.11ax HE80 Full CH155 5775MHz	
0+1	Vertical	Fundamental
Peak	<p>Site : 03CH15-HY Condition : PEAK_BE(84)_16-24 3m 91200_15_1620 VERTICAL Detector : Peak Project : 041657</p>	<p>Site : 03CH15-HY Condition : PEAK(UNII) 3m 91200_15_1620 VERTICAL Detector : Peak Project : 041657</p>
Peak	<p>Site : 03CH15-HY Condition : PEAK_BE(84)_16-24 3m 91200_15_1620 VERTICAL Detector : Peak Project : 041657</p>	Left blank

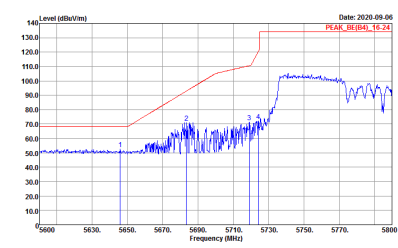
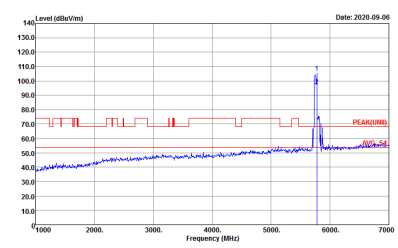
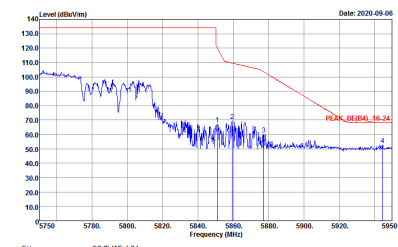

Band 4 5725~5850MHz
WIFI 802.11ax HE80 Partial 484 (Band Edge @ 3m)

WIFI	Band 4 5725~5850MHz Band Edge @ 3m	
ANT	802.11ax HE80 Partial 484/65 CH155 5775MHz	
0+1	Horizontal	Fundamental
Peak	 <p>Date: 2020-09-06 PEAK_BE(B4)_16-24</p> <p>Site : 03CH15-HY Condition : PEAK_BE(B4)_16-24 3m 91200_15_1620 HORIZONTAL RBW:1000.000kHz VBW:3000.000kHz SWT:Auto Detector : Peak Project : 041657</p>	 <p>Date: 2020-09-06 PEAK(UMB)</p> <p>Site : 03CH15-HY Condition : PEAK(UNIT) 3m 91200_15_1620 HORIZONTAL RBW:1000.000kHz VBW:3000.000kHz SWT:Auto Detector : Peak Project : 041657</p>
Peak	 <p>Date: 2020-09-06 PEAK_BE(B4)_16-24</p> <p>Site : 03CH15-HY Condition : PEAK_BE(B4)_16-24 3m 91200_15_1620 HORIZONTAL RBW:1000.000kHz VBW:3000.000kHz SWT:Auto Detector : Peak Project : 041657</p>	Left blank



WIFI	Band 4 5725~5850MHz Band Edge @ 3m	
ANT	802.11ax HE80 Partial 484/65 CH155 5775MHz	
0+1	Vertical	Fundamental
Peak	<p>Site : 03CH15-HY Condition : PEAK_BE(B4)_16-24 3m 91200_15_1620 VERTICAL Detector : Peak Project : 041657</p>	<p>Site : 03CH15-HY Condition : PEAK(UNII) 3m 91200_15_1620 VERTICAL Detector : Peak Project : 041657</p>
Peak	<p>Site : 03CH15-HY Condition : PEAK_BE(B4)_16-24 3m 91200_15_1620 VERTICAL Detector : Peak Project : 041657</p>	Left blank

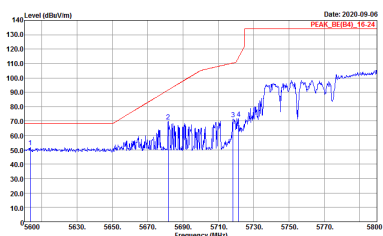
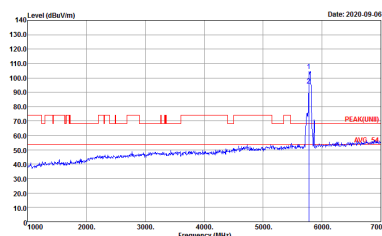
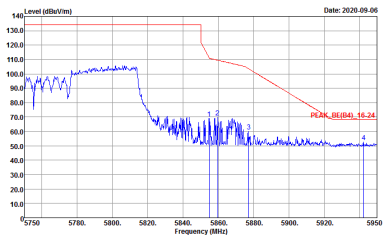

WIFI	Band 4 5725~5850MHz Band Edge @ 3m	
ANT	802.11ax HE80 Partial 484/66 CH155 5775MHz	
0+1	Horizontal	Fundamental
Peak	 <p>Date: 2020-09-06 PEAK_BE(84)_16-24</p> <p>Site : 03CH15-HY Condition : PEAK_BE(84)_16-24 3m 91200_15_1620 HORIZONTAL Detector : Peak Project : 041657</p>	 <p>Date: 2020-09-06 PEAK(UNII)_3m 91200_15_1620 HORIZONTAL</p> <p>Site : 03CH15-HY Condition : PEAK(UNII)_3m 91200_15_1620 HORIZONTAL Detector : Peak Project : 041657</p>
Peak	 <p>Date: 2020-09-06 PEAK_BE(84)_16-24</p> <p>Site : 03CH15-HY Condition : PEAK_BE(84)_16-24 3m 91200_15_1620 HORIZONTAL Detector : Peak Project : 041657</p>	Left blank

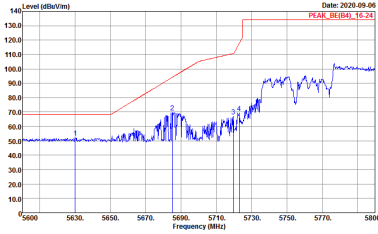
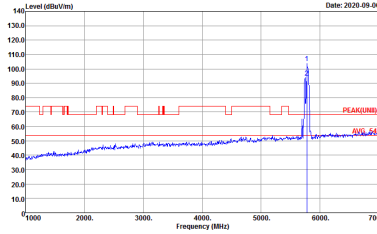
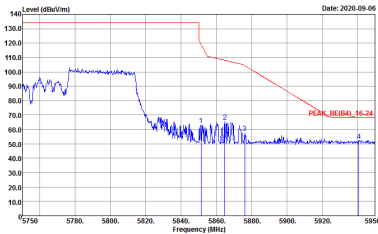

WIFI	Band 4 5725~5850MHz Band Edge @ 3m	
ANT	802.11ax HE80 Partial 484/66 CH155 5775MHz	
0+1	Vertical	Fundamental
Peak	 <p>Date: 2020-09-06 PEAK_BE(84)_16-24</p> <p>Site : 03CH15-HY Condition : PEAK_BE(84)_16-24 3m 91200_15_1620 VERTICAL Detector : Peak Project : 041657</p>	 <p>Date: 2020-09-06 PEAK(84)_16-24</p> <p>Site : 03CH15-HY Condition : PEAK(UNII) 3m 91200_15_1620 VERTICAL Detector : Peak Project : 041657</p>
Peak	 <p>Date: 2020-09-06 PEAK_BE(84)_16-24</p> <p>Site : 03CH15-HY Condition : PEAK_BE(84)_16-24 3m 91200_15_1620 VERTICAL Detector : Peak Project : 041657</p>	Left blank



Band 4 - 5725~5850MHz
WIFI 802.11a (Harmonic @ 3m)

WIFI	Band 4 5725~5850MHz Harmonic @ 3m	
ANT	802.11a CH149 5745MHz	
0+1	Horizontal	Vertical
Peak Avg.	<p>Site : 03CH15-1FY Condition : PEAK(LINEI) 3m 9120D_15_1620 HORIZONTAL Detector : Peak Project : 041657</p>	<p>Site : 03CH15-1FY Condition : PEAK(LINEI) 3m 9120D_15_1620 VERTICAL Detector : Peak Project : 041657</p>



WIFI	Band 4 5725~5850MHz Harmonic @ 3m	
ANT	802.11a CH157 5785MHz	
0+1	Horizontal	Vertical
Peak Avg.	<p>Site : 03CH15-HY Condition : PEAK(UNII) 3m 91200_15_1620 HORIZONTAL Detector : Peak Project : 041657</p>	<p>Site : 03CH15-HY Condition : PEAK(UNII) 3m 91200_15_1620 VERTICAL Detector : Peak Project : 041657</p>



WIFI	Band 4 5725~5850MHz Harmonic @ 3m	
ANT	802.11a CH165 5825MHz	
0+1	Horizontal	Vertical
Peak Avg.	<p>Site : 03CH15-HY Condition : PEAK(UNID) 3m 91200_15_1620 HORIZONTAL Detector : Peak Project : 041657</p>	<p>Site : 03CH15-HY Condition : PEAK(UNID) 3m 91200_15_1620 VERTICAL Detector : Peak Project : 041657</p>



Band 4 5725~5850MHz
WIFI 802.11ax HE20 Full (Harmonic @ 3m)

WIFI	Band 4 5725~5850MHz Harmonic @ 3m	
ANT	802.11ax HE20 Full CH149 5745MHz	
0+1	Horizontal	Vertical
Peak Avg.	<p>Site : 03CH15-HY Condition : PEAK(UNII) 3m 9120D_15_1620 HORIZONTAL Detector : Peak Project : 041657</p>	<p>Site : 03CH15-HY Condition : PEAK(UNII) 3m 9120D_15_1620 VERTICAL Detector : Peak Project : 041657</p>

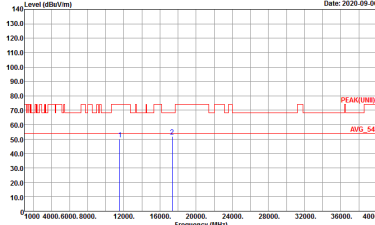
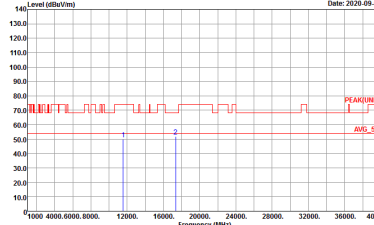

WIFI	Band 4 5725~5850MHz Harmonic @ 3m	
ANT	802.11ax HE20 Full CH157 5785MHz	
0+1	Horizontal	Vertical
<p>Peak</p> <p>Avg.</p>	 <p>Date: 2020-09-06</p> <p>Site : 03CH15-HY Condition : PEAK(UNII) 3m 91200_15_1620 HORIZONTAL Detector : Peak Project : 041657</p>	 <p>Date: 2020-09-06</p> <p>Site : 03CH15-HY Condition : PEAK(UNII) 3m 91200_15_1620 VERTICAL Detector : Peak Project : 041657</p>

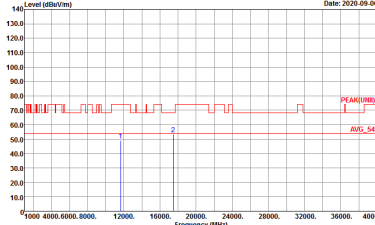
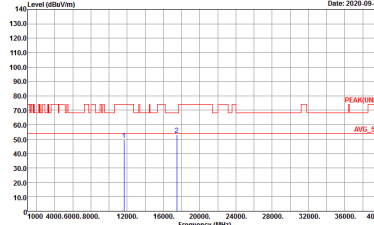

WIFI	Band 4 5725~5850MHz Harmonic @ 3m	
ANT	802.11ax HE20 Full CH165 5825MHz	
0+1	Horizontal	Vertical
<p>Peak</p> <p>Avg.</p>	 <p>Site : 03CH15-HY Condition : PEAK(UNII) 3m 91200_15_1620 HORIZONTAL Detector : Peak Project : 041657</p>	 <p>Site : 03CH15-HY Condition : PEAK(UNII) 3m 91200_15_1620 VERTICAL Detector : Peak Project : 041657</p>



**Band 4 5725~5850MHz
WIFI 802.11ax HE40 Full (Harmonic @ 3m)**

WIFI	Band 4 5725~5850MHz Harmonic @ 3m	
ANT	802.11ax HE40 Full CH151 5755MHz	
0+1	Horizontal	Vertical
Peak Avg.	<p>Site : 03CH15-HY Condition : PEAK(UNIT) 3m 91200_15_1620 HORIZONTAL Detector : Peak Project : 041657</p>	<p>Site : 03CH15-HY Condition : PEAK(UNIT) 3m 91200_15_1620 VERTICAL Detector : Peak Project : 041657</p>



WIFI	Band 4 5725~5850MHz Harmonic @ 3m	
ANT	802.11ax HE40 Full CH159 5795MHz	
0+1	Horizontal	Vertical
Peak Avg.	<p>Site : 03CH15-HY Condition : PEAK(UNII) 3m 9120D_15_1620 HORIZONTAL Detector : Peak Project : 041657</p>	<p>Site : 03CH15-HY Condition : PEAK(UNII) 3m 9120D_15_1620 VERTICAL Detector : Peak Project : 041657</p>



**Band 4 5725~5850MHz
WIFI 802.11ax HE80 Full (Harmonic @ 3m)**

WIFI	Band 4 5725~5850MHz Harmonic @ 3m	
ANT	802.11ax HE80 Full CH155 5775MHz	
0+1	Horizontal	Vertical
Peak Avg.	<p>Site : 03CH15-HY Condition : PEAK(UNIT) 3m 91200_15_1620 HORIZONTAL Detector : Peak Project : 041657</p>	<p>Site : 03CH15-HY Condition : PEAK(UNIT) 3m 91200_15_1620 VERTICAL Detector : Peak Project : 041657</p>



Emission below 1GHz
5GHz WIFI 802.11ax HE40 Full (LF)

WIFI	5GHz WIFI	
ANT	802.11ax HE40 Full LF	
0+1	Horizontal	Vertical
QP / Peak	<p>Site : 03CH15-HY Condition : QP 3m BTL0G_15_41912 HORIZONTAL Detector : Peak Project : 041657</p>	<p>Site : 03CH15-HY Condition : QP 3m BTL0G_15_41912 VERTICAL Detector : Peak Project : 041657</p>



Appendix E. Duty Cycle Plots

Antenna	Band	Duty Cycle(%)	T(us)	1/T(kHz)	VBW Setting	Duty Factor(dB)
0+1	802.11a for Ant 0	98.51	-	-	10Hz	0.07
0+1	802.11a for Ant 1	98.50	-	-	10Hz	0.07
0+1	5GHz 802.11ax HE20 Full RU for Ant 0	100.00	-	-	10Hz	0.00
0+1	5GHz 802.11ax HE20 Full RU for Ant 1	100.00	-	-	10Hz	0.00
0+1	5GHz 802.11ax HE40 Full RU for Ant 0	100.00	-	-	10Hz	0.00
0+1	5GHz 802.11ax HE40 Full RU for Ant 1	100.00	-	-	10Hz	0.00
0+1	5GHz 802.11ax HE80 Full RU for Ant 0	100.00	-	-	10Hz	0.00
0+1	5GHz 802.11ax HE80 Full RU for Ant 1	100.00	-	-	10Hz	0.00



MIMO <Ant. 0>

802.11a

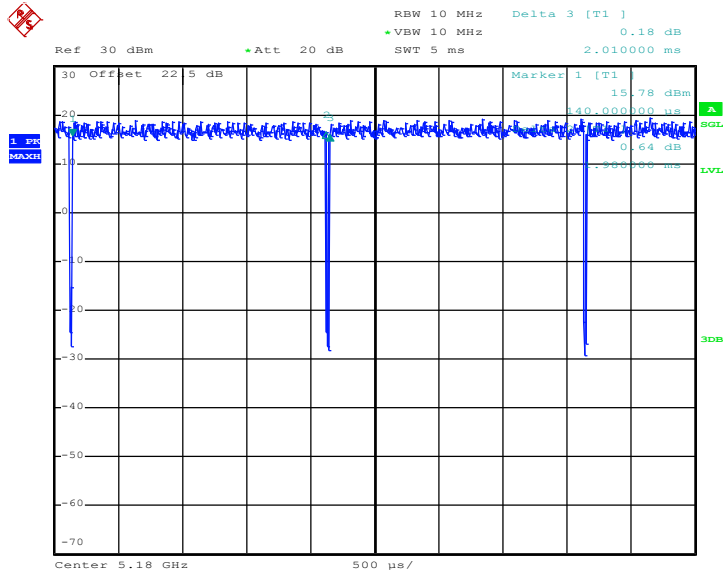

Date: 27.JUL.2020 13:48:35

802.11ax HE20 Full RU

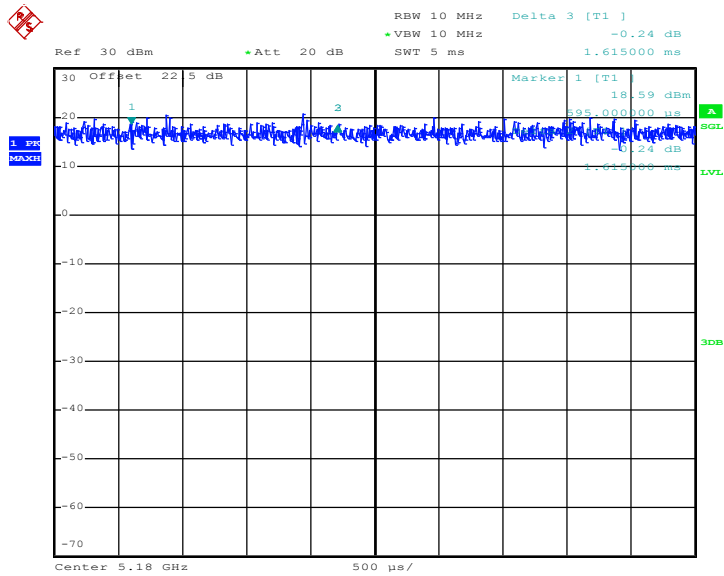

Date: 27.JUL.2020 11:04:06



802.11ax HE40 Full RU

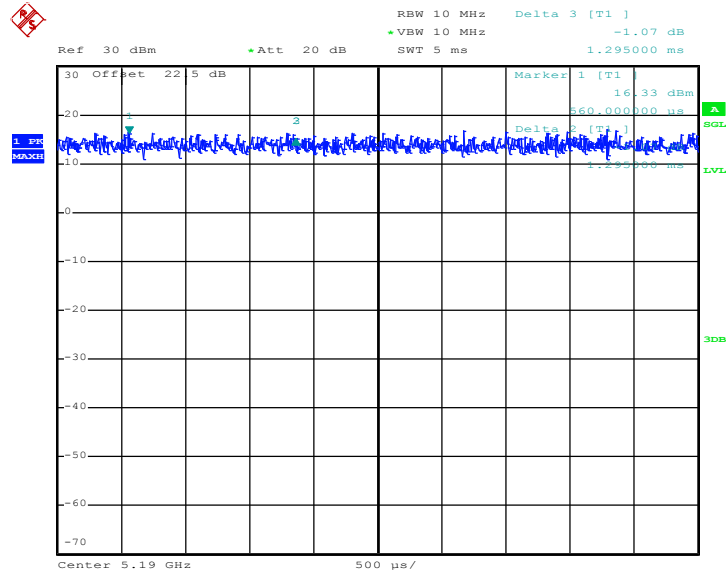

Date: 27.JUL.2020 11:18:51

802.11ax HE80 Full RU

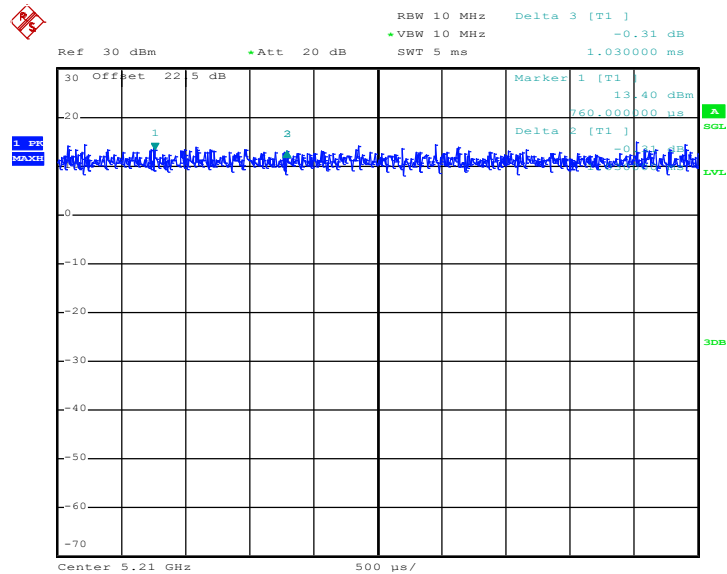

Date: 27.JUL.2020 11:27:37



MIMO <Ant. 1>

802.11a

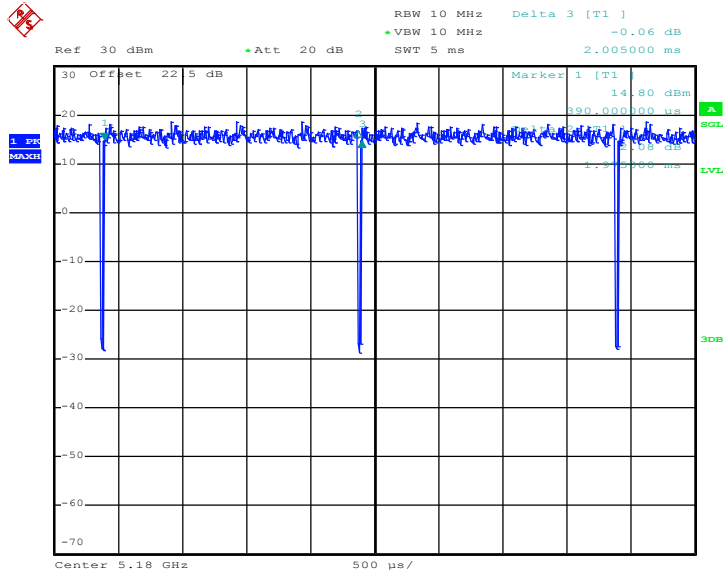

Date: 27.JUL.2020 13:47:07

802.11ax HE20 Full RU

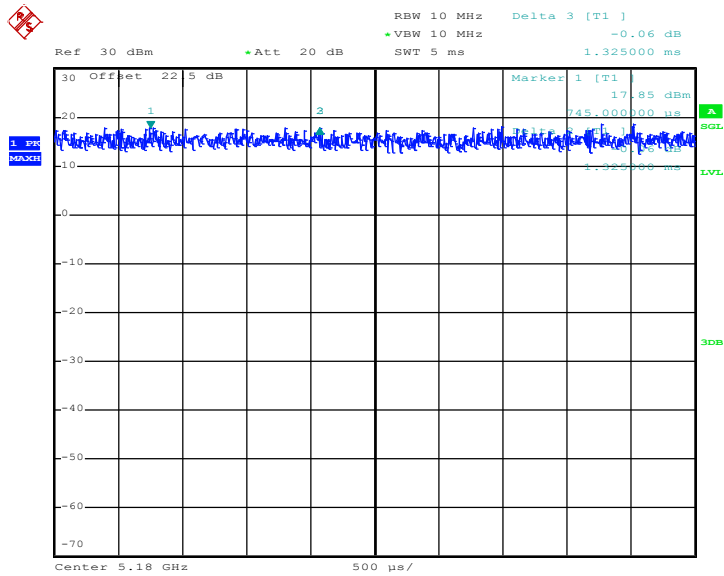

Date: 27.JUL.2020 11:05:38



802.11ax HE40 Full RU

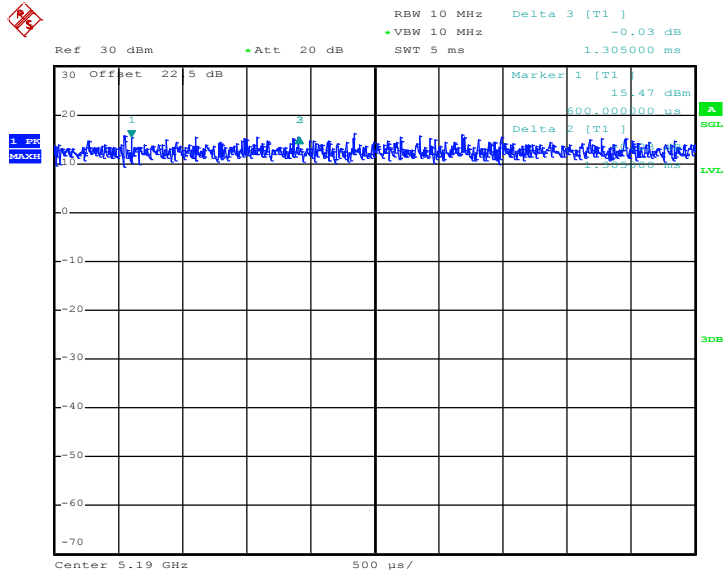

Date: 27.JUL.2020 11:17:58

802.11ax HE80 Full RU

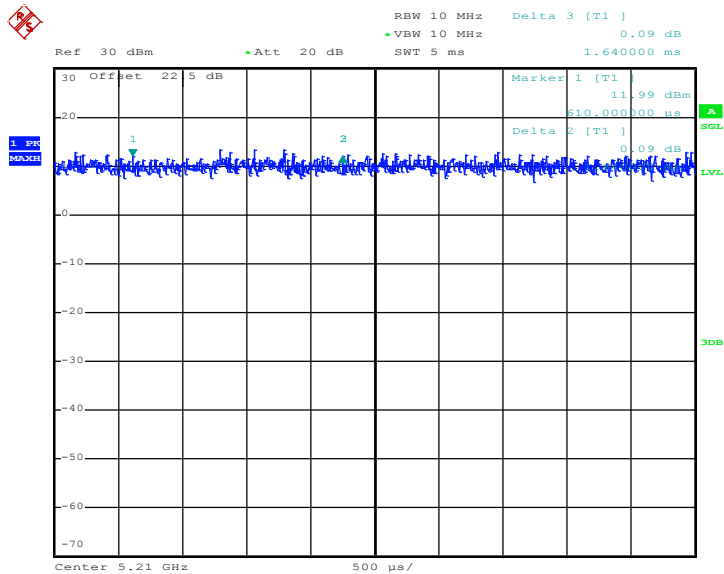

Date: 27.JUL.2020 11:29:20