



FCC RADIO TEST REPORT

FCC ID : PKRISGM2000A
Equipment : Wireless Hotspot Modem
Brand Name : Inseego
Model Name : M2000A
Marketing Name : M2000
Applicant : Inseego Corporation
9710 Scranton Road Suite 200, San Diego, CA 92121
Manufacturer : Inseego Corporation
9710 Scranton Road Suite 200, San Diego, CA 92121
Standard : FCC Part 15 Subpart E §15.407

The product was received on Jul. 09, 2020 and testing was started from Jul. 23, 2020 and completed on Sep. 08, 2020. We, SPORTON INTERNATIONAL INC., EMC & Wireless Communications Laboratory, would like to declare that the tested sample has been evaluated in accordance with the test procedures and has been in compliance with the applicable technical standards.

The test results in this report apply exclusively to the tested model / sample. Without written approval of SPORTON INTERNATIONAL INC. EMC & Wireless Communications Laboratory, the test report shall not be reproduced except in full.

Louis Wu

Approved by: Louis Wu

SPORTON INTERNATIONAL INC. EMC & Wireless Communications Laboratory
No. 52, Huaya 1st Rd., Guishan Dist., Taoyuan City, Taiwan (R.O.C.)



Table of Contents

History of this test report.....	3
Summary of Test Result.....	4
1 General Description	5
1.1 Product Feature of Equipment Under Test.....	5
1.2 Modification of EUT	5
1.3 Testing Location	6
1.4 Applicable Standards.....	6
2 Test Configuration of Equipment Under Test	7
2.1 Carrier Frequency and Channel	7
2.2 Test Mode.....	8
2.3 Connection Diagram of Test System.....	8
2.4 Support Unit used in test configuration and system	10
2.5 EUT Operation Test Setup	10
2.6 Measurement Results Explanation Example.....	10
3 Test Result	11
3.1 26dB & 99% Occupied Bandwidth Measurement	11
3.2 Maximum Conducted Output Power Measurement	14
3.3 Power Spectral Density Measurement	15
3.4 Unwanted Emissions Measurement.....	18
3.5 AC Conducted Emission Measurement.....	23
3.6 Automatically Discontinue Transmission	25
3.7 Antenna Requirements.....	26
4 List of Measuring Equipment.....	27
5 Uncertainty of Evaluation	29
Appendix A. Conducted Test Results	
Appendix B. AC Conducted Emission Test Result	
Appendix C. Radiated Spurious Emission	
Appendix D. Radiated Spurious Emission Plots	
Appendix E. Duty Cycle Plots	
Appendix F. Setup Photographs	



History of this test report

Report No.	Version	Description	Issued Date
FR041657B	01	Initial issue of report	Sep. 16, 2020



Summary of Test Result

Report Clause	Ref Std. Clause	Test Items	Result (PASS/FAIL)	Remark
3.1	15.403(i)	26dB Bandwidth	Pass	-
3.1	2.1049	99% Occupied Bandwidth	Reporting only	-
3.2	15.407(a)	Maximum Conducted Output Power	Pass	-
3.3	15.407(a)	Power Spectral Density	Pass	-
3.4	15.407(b)	Unwanted Emissions	Pass	Under limit 5.08 dB at 5149.500 MHz
3.5	15.207	AC Conducted Emission	Pass	Under limit 17.34 dB at 0.150 MHz
3.6	15.407(c)	Automatically Discontinue Transmission	Pass	-
3.7	15.203 15.407(a)	Antenna Requirement	Pass	-

Declaration of Conformity:

The test results with all measurement uncertainty excluded are presented in accordance with the regulation limits or requirements declared by manufacturers.

Comments and Explanations:

The declared of product specification for EUT presented in the report are provided by the manufacturer, and the manufacturer takes all the responsibilities for the accuracy of product specification.

Reviewed by: Wii Chang**Report Producer: Celery Wei**



1 General Description

1.1 Product Feature of Equipment Under Test

WCDMA/LTE/5G NR, Wi-Fi 2.4GHz 802.11b/g/n/ax, Wi-Fi 5GHz 802.11a/n/ac/ax and GNSS.

Product Specification subjective to this standard	
Antenna Type	WWAN: Fixed Internal Antenna WLAN: <Ant. 0>: Fixed Internal Antenna <Ant. 1>: Fixed Internal Antenna GPS: Fixed Internal Antenna

1.2 Modification of EUT

No modifications are made to the EUT during all test items.



1.3 Testing Location

Test Site	SPORTON INTERNATIONAL INC. EMC & Wireless Communications Laboratory	
Test Site Location	No.52, Huaya 1st Rd., Guishan Dist., Taoyuan City, Taiwan (R.O.C.) TEL: +886-3-327-3456 FAX: +886-3-328-4978	
Test Site No.	Sporton Site No.	
	TH05-HY	CO05-HY

Note: The test site complies with ANSI C63.4 2014 requirement.

Test Site	SPORTON INTERNATIONAL INC. EMC & Wireless Communications Laboratory	
Test Site Location	No.58, Aly. 75, Ln. 564, Wenhua 3rd, Rd., Guishan Dist., Taoyuan City, Taiwan (R.O.C.) TEL: +886-3-327-0868 FAX: +886-3-327-0855	
Test Site No.	Sporton Site No.	
	03CH15-HY	

Note: The test site complies with ANSI C63.4 2014 requirement.

FCC designation No.: TW1190 and TW0007

1.4 Applicable Standards

According to the specifications of the manufacturer, the EUT must comply with the requirements of the following standards:

- ♦ FCC Part 15 Subpart E
- ♦ FCC KDB 789033 D02 General UNII Test Procedures New Rules v02r01.
- ♦ FCC KDB 414788 D01 Radiated Test Site v01r01.
- ♦ FCC KDB 662911 D01 Multiple Transmitter Output v02r01.
- ♦ ANSI C63.10-2013

Remark:

1. All test items were verified and recorded according to the standards and without any deviation during the test.
2. The TAF code is not including all the FCC KDB listed without accreditation.
3. This EUT has also been tested and complied with the requirements of FCC Part 15, Subpart B, recorded in a separate test report.



2 Test Configuration of Equipment Under Test

- a. The EUT has been associated with peripherals and configuration operated in a manner tended to maximize its emission characteristics in a typical application. Frequency range investigated: conduction emission (150 kHz to 30 MHz), radiation emission (9 kHz to the 10th harmonic of the highest fundamental frequency or to 40 GHz, whichever is lower). For radiated measurement, pre-scanned in three orthogonal panels, X, Y, Z. The worst cases (X plane) were recorded in this report.

- b. AC power line Conducted Emission was tested under maximum output power.

2.1 Carrier Frequency and Channel

Frequency Band	Channel	Freq. (MHz)	Channel	Freq. (MHz)
5150-5250 MHz Band 1 (U-NII-1)	36	5180	44	5220
	38*	5190	46*	5230
	40	5200	48	5240
	42#	5210		

Note:

- 1. The above Frequency and Channel in "*" were 802.11n HT40, 802.11ac VHT40 and 802.11ax HE40.
- 2. The above Frequency and Channel in "#" were 802.11ac VHT80 and 802.11ax HE80.



2.2 Test Mode

Final test modes are considering the modulation and worse data rates as below table.

The CDD mode is chosen as worst case configuration for all test cases due to higher power than SISO mode.

The 802.11ax mode is investigated among different tones, full resource units (RU), partial resource units. The partial RU has no higher power and PSD than full RU's, thus the full RU is chosen as main test configuration, and the partial RU is verified the band edge in accordance with the TCB workshop, Oct. 3rd .2018.

Modulation	Data Rate
802.11a	6 Mbps
802.11n HT20 (Covered by HE20)	MCS0
802.11n HT40 (Covered by HE40)	MCS0
802.11ac VHT20 (Covered by HE20)	MCS0
802.11ac VHT40 (Covered by HE40)	MCS0
802.11ac VHT80 (Covered by HE80)	MCS0
802.11ax HE20	MCS0
802.11ax HE40	MCS0
802.11ax HE80	MCS0

Test Cases	
AC Conducted Emission	Mode 1 : WCDMA 850 Idle + WLAN (5GHz) Link + Battery 1 + Adapter
Remark: For Radiated Test Cases, the tests were performed with Battery 2.	

Ch. #		Band I : 5150-5250 MHz			
		802.11a	802.11ax HE20	802.11ax HE40	802.11ax HE80
L	Low	36	36	38	-
M	Middle	44	44	-	42
H	High	48	48	46	-

Remark: For radiation spurious emission, the final modulation and the worst data rate was reference the max RF conducted power, the worst mode of WLAN and LTE for simultaneous transmission were verified and compliant.

2.3 Connection Diagram of Test System

<AC Conducted Emission Mode>

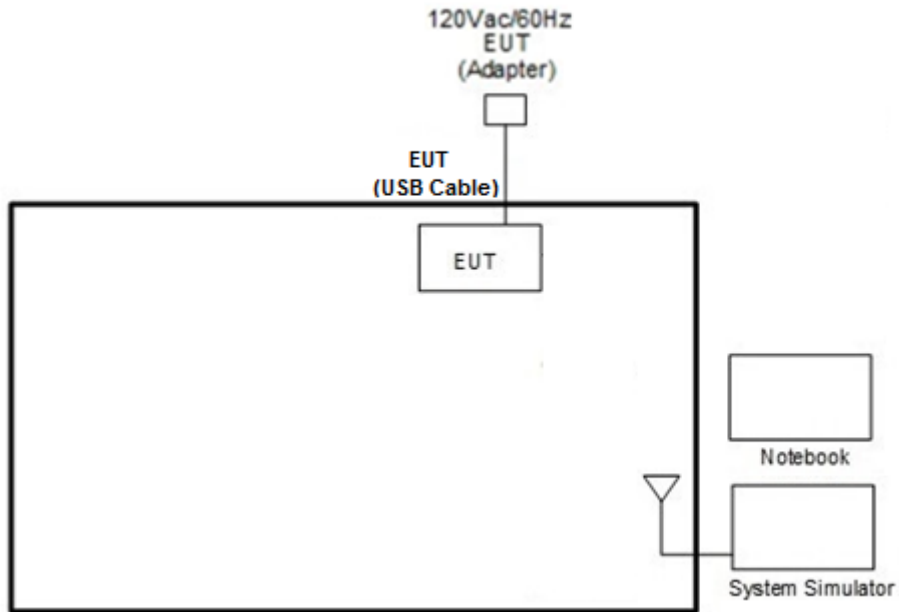

<WLAN Tx Mode>

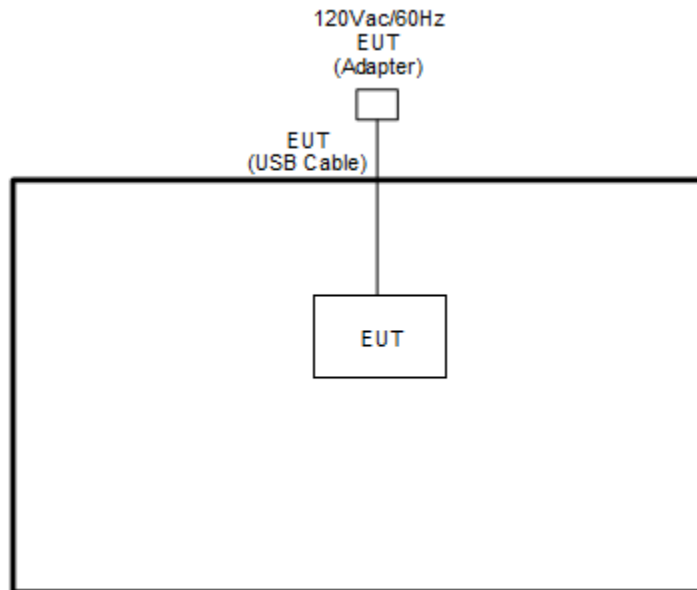



2.4 Support Unit used in test configuration and system

Item	Equipment	Brand Name	Model Name	FCC ID	Data Cable	Power Cord
1.	System Simulator	Anritsu	MT8820C	N/A	N/A	Unshielded, 1.8 m
2.	Notebook	Dell	Latitude 3400	FCC DoC	N/A	AC I/P: Unshielded, 1.2 m DC O/P: Shielded, 1.8 m

2.5 EUT Operation Test Setup

The RF test items, utility “QRCT V4.0.00156.0” was installed in Notebook which was programmed in order to make the EUT get into the engineering modes to provide channel selection, power level, data rate and the application type and for continuous transmitting signals.

2.6 Measurement Results Explanation Example

For all conducted test items:

The offset level is set in the spectrum analyzer to compensate the RF cable loss and attenuator factor between EUT conducted output port and spectrum analyzer. With the offset compensation, the spectrum analyzer reading level is exactly the EUT RF output level.

Example :

The spectrum analyzer offset is derived from RF cable loss and attenuator factor.

Offset = RF cable loss + attenuator factor.

Following shows an offset computation example with cable loss 4.2 dB and 10dB attenuator.

$$\begin{aligned}
 \text{Offset(dB)} &= \text{RF cable loss(dB)} + \text{attenuator factor(dB)}. \\
 &= 4.2 + 10 = 14.2 \text{ (dB)}
 \end{aligned}$$

3 Test Result

3.1 26dB & 99% Occupied Bandwidth Measurement

3.1.1 Description of 26dB & 99% Occupied Bandwidth

This section is for reporting purpose only.

There is no restriction limits for bandwidth.

3.1.2 Measuring Instruments

See list of measuring equipment of this test report.

3.1.3 Test Procedures

1. The testing follows FCC KDB 789033 D02 General UNII Test Procedures New Rules v02r01. Section C) Emission bandwidth
2. Set RBW = approximately 1% of the emission bandwidth.
3. Set the VBW > RBW.
4. Detector = Peak.
5. Trace mode = max hold
6. Measure the maximum width of the emission that is 26 dB down from the peak of the emission. Compare this with the RBW setting of the analyzer. Readjust RBW and repeat measurement as needed until the RBW/EBW ratio is approximately 1%.
7. For 99% Bandwidth Measurement, the spectrum analyzer's resolution bandwidth (RBW) is set 1-5% of the emission bandwidth and set the Video bandwidth (VBW) $\geq 3 * RBW$.
8. Measure and record the results in the test report.

3.1.4 Test Setup

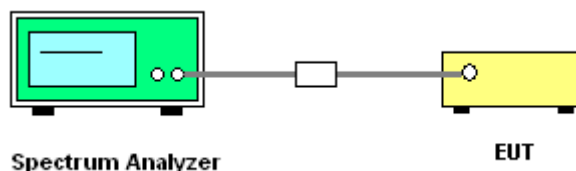

3.1.5 Test Result of 26dB & 99% Occupied Bandwidth

Please refer to Appendix A.

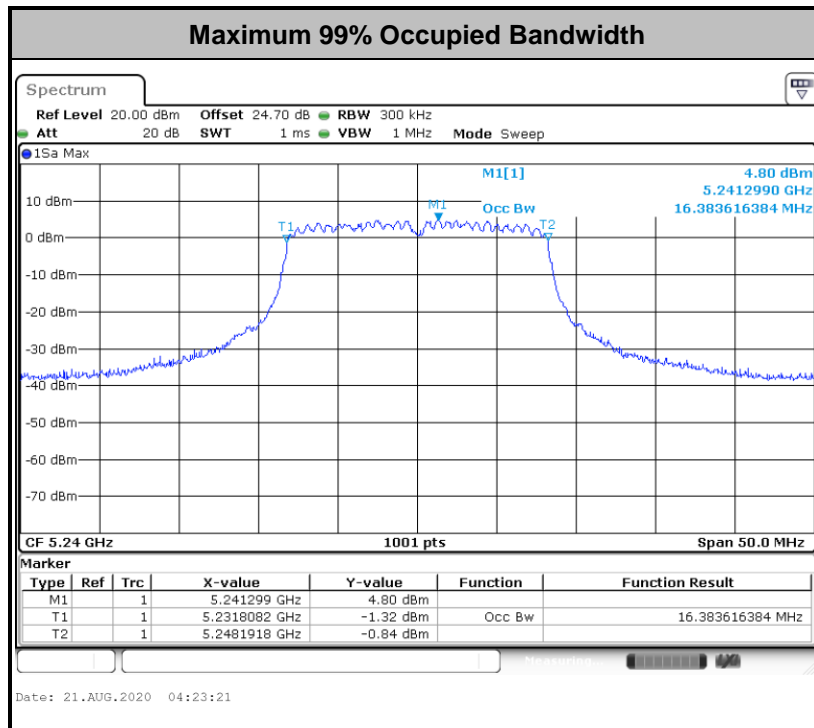
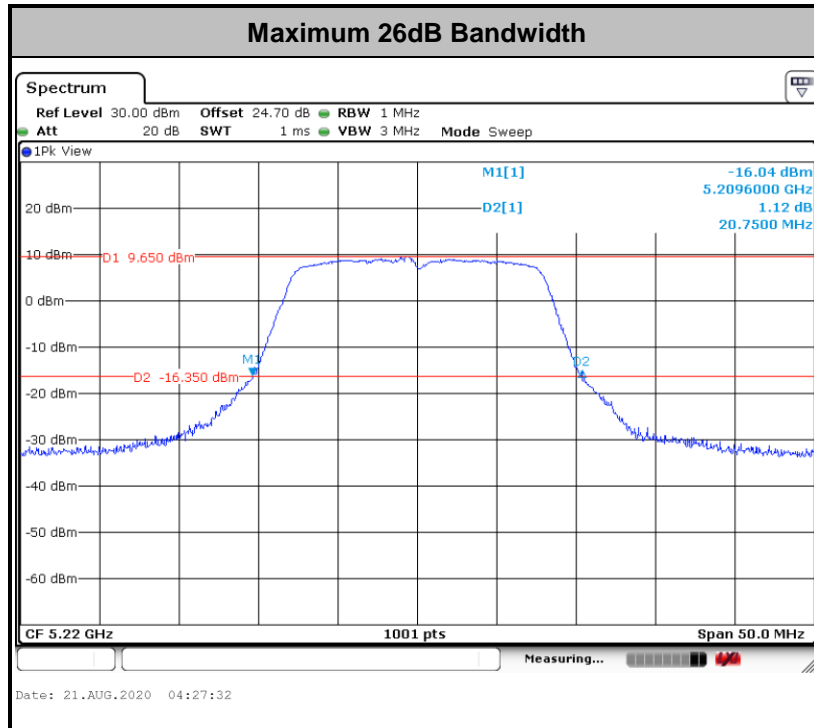

Note: The occupied channel bandwidth is maintained within the band of operation for all of the modulations.



<For 802.11ax Mode>

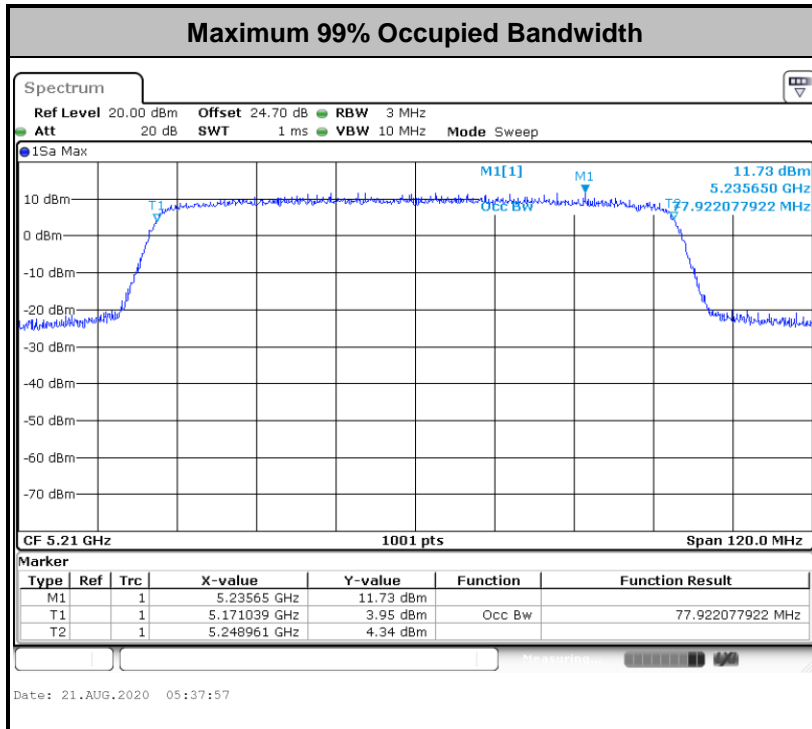
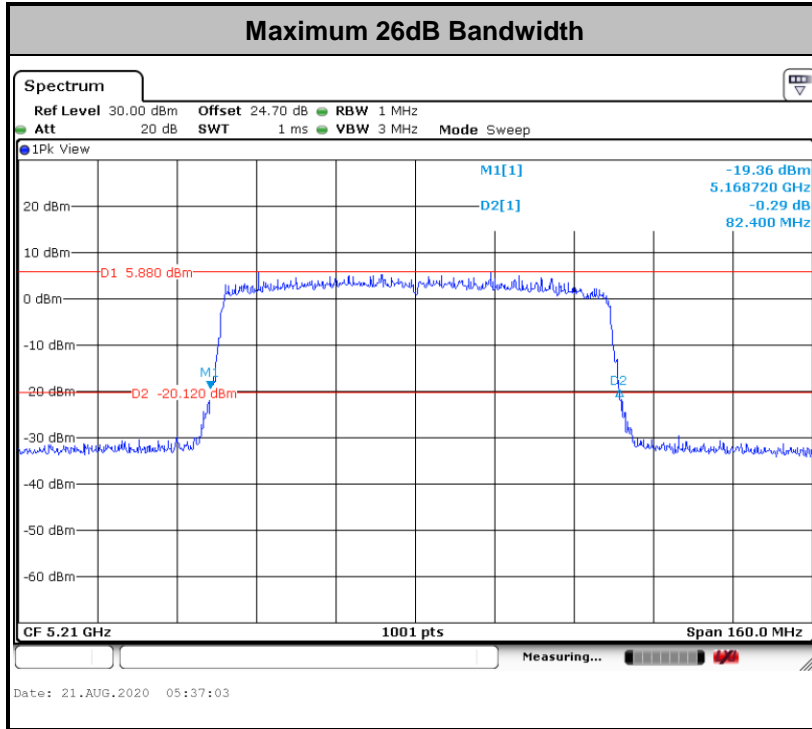

Note: The occupied channel bandwidth is maintained within the band of operation for all of the modulations.

3.2 Maximum Conducted Output Power Measurement

3.2.1 Limit of Maximum Conducted Output Power

<FCC 14-30 CFR 15.407>

For the 5.15–5.25 GHz bands:

- For mobile and portable client devices in the 5.15–5.25 GHz band, the maximum conducted output power over the frequency band of operation shall not exceed 250 mW. For an indoor access point operating in the band 5.15-5.25 GHz, the maximum conducted output power over the frequency band of operation shall not exceed 1 W.

If transmitting antennas of directional gain greater than 6 dBi are used, the peak output power shall be reduced by the amount in dB that the directional gain of the antenna exceeds 6 dBi.

Note that U-NII-2 band, devices with a maximum e.i.r.p. greater than 500 mW shall implement TPC in order to have the capability to operate at least 6 dB below the maximum permitted e.i.r.p. of 1 W.

3.2.2 Measuring Instruments

See list of measuring equipment of this test report.

3.2.3 Test Procedures

The testing follows Method PM-G of FCC KDB 789033 D02 General UNII Test Procedures New Rules v02r01.

Method PM-G (Measurement using an RF average power meter):

1. Measurement is performed using a wideband RF power meter.
2. The EUT is configured to transmit at its maximum power control level.
3. Measure the average power of the transmitter
4. Since the measurement is made only during the ON time of the transmitter, no duty cycle correction factor is required.

3.2.4 Test Setup

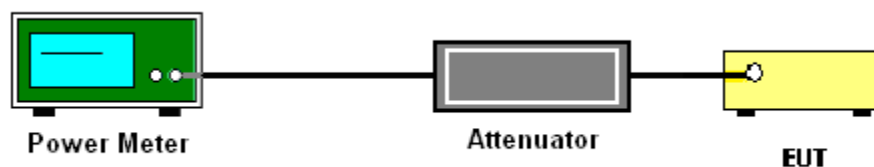

3.2.5 Test Result of Maximum Conducted Output Power

Please refer to Appendix A.



3.3 Power Spectral Density Measurement

3.3.1 Limit of Power Spectral Density

<FCC 14-30 CFR 15.407>

For the 5.15–5.25 GHz bands:

For mobile and portable client devices in the 5.15–5.25 GHz band, the maximum power spectral density shall not exceed 11 dBm in any 1.0 MHz band. For an indoor access point operating in the band 5.15-5.25 GHz, the maximum power spectral density shall not exceed 17 dBm in any 1.0 MHz band.

If transmitting antennas of directional gain greater than 6 dBi are used, the peak output power shall be reduced by the amount in dB that the directional gain of the antenna exceeds 6 dBi.

3.3.2 Measuring Instruments

See list of measuring equipment of this test report.

3.3.3 Test Procedures

The testing follows FCC KDB 789033 D02 General UNII Test Procedures New Rules v02r01. Section F) Maximum power spectral density.

Method SA-3

(power averaging (rms) detection with max hold):

- Set span to encompass the entire emission bandwidth (EBW) of the signal.
- Set RBW = 1 MHz.
- Set VBW \geq 3 MHz
- Number of points in sweep \geq 2 Span / RBW.
- Sweep time \leq (number of points in sweep) \times T, when duty cycle is less than 98 percent where T is the minimum transmission duration over which the transmitter is on and is transmitting at its maximum power control level for the tested mode of operation.
- Detector = power averaging (rms).
- Trace mode = max hold.
- Allow max hold to run for at least 60 seconds, or longer as needed to allow the trace to stabilize.

1. The RF output of EUT was connected to the spectrum analyzer by a low loss cable.
2. Each plot has already offset with cable loss, and attenuator loss. Measure the PPSD and record it.
3. For MIMO mode, calculation method follows FCC KDB 662911 D01 Multiple Transmitter Output v02r01.

Method (a): Measure and sum the spectra across the outputs.

The total final Power Spectral Density is from a device with 2 transmitter outputs. The spectrum measurements of the individual outputs are all performed with the same span and number of points; the spectrum value in the first spectral bin of output 1 is summed with that in the first spectral bin of output 2 to obtain the value for the first frequency bin of the summed spectrum.

3.3.4 Test Setup

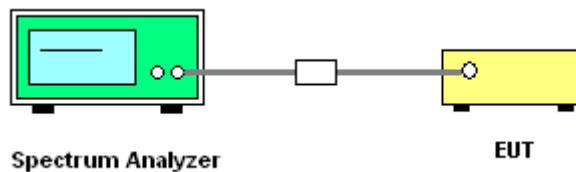

3.3.5 Test Result of Power Spectral Density

Please refer to Appendix A.

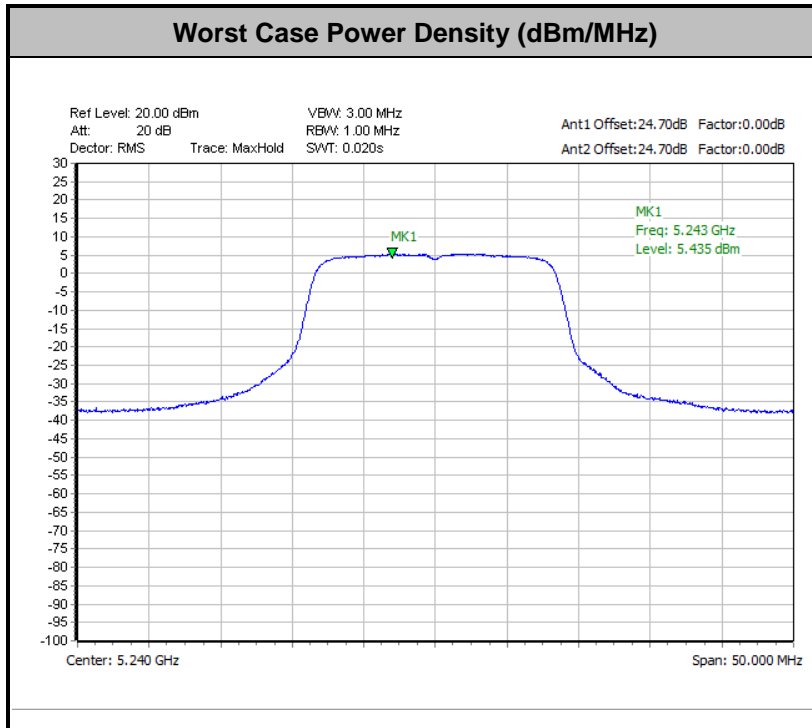

Note: Average Power Density (dB) = Measured value+ Duty Factor

<For 802.11ax Mode>

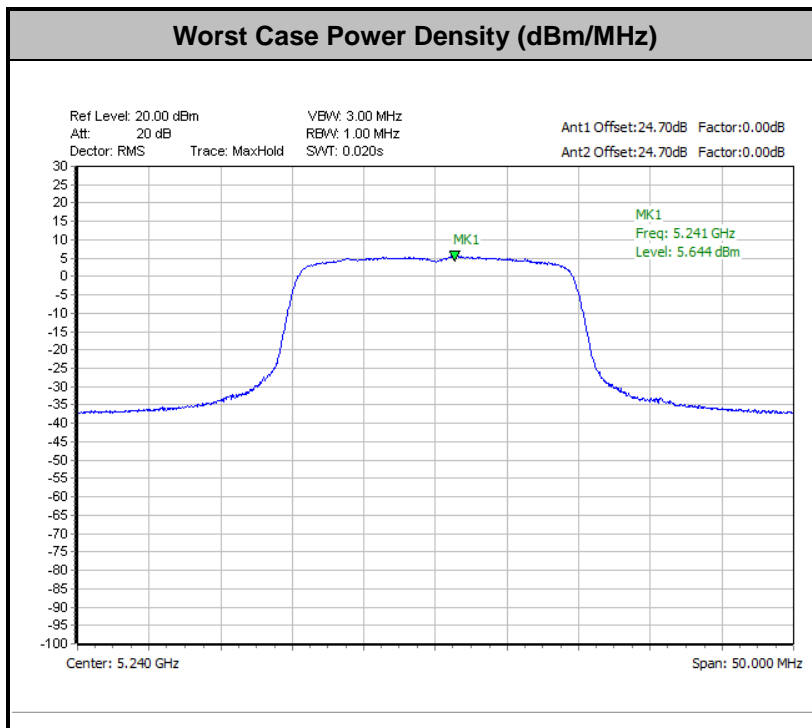

Note: Average Power Density (dB) = Measured value+ Duty Factor



3.4 Unwanted Emissions Measurement

This section is to measure unwanted emissions through radiated measurement for band edge spurious emissions and out of band emissions measurement.

3.4.1 Limit of Unwanted Emissions

- (1) For transmitters operating in the 5150-5250 MHz band: all emissions outside of the 5150-5350 MHz band shall not exceed an EIRP of -27dBm/MHz.
- (2) Unwanted spurious emissions fallen in restricted bands shall comply with the general field strength limits as below table:

Frequency (MHz)	Field Strength (microvolts/meter)	Measurement Distance (meters)
0.009 – 0.490	2400/F(kHz)	300
0.490 – 1.705	24000/F(kHz)	30
1.705 – 30.0	30	30
30 – 88	100	3
88 – 216	150	3
216 - 960	200	3
Above 960	500	3

Note: The following formula is used to convert the EIRP to field strength.

$$E = \frac{1000000\sqrt{30P}}{3} \mu V/m, \text{ where } P \text{ is the eirp (Watts)}$$

EIRP (dBm)	Field Strength at 3m (dBμV/m)
- 27	68.3

- (3) KDB789033 D02 v02r01 G)2)c)
 - (i) Sections 15.407(b)(1-3) specifies the unwanted emissions limit for the U-NII-1 and U-NII-2 bands. As specified, emissions above 1000 MHz that are outside of the restricted bands are subject to a peak emission limit of -27 dBm/MHz.
 - (ii) Section 15.407(b)(4) specifies the unwanted emissions limit for the U-NII-3 band. A band emissions mask is specified in Section 15.407(b)(4)(i). The emission limits are based on the use of a peak detector.

3.4.2 Measuring Instruments

See list of measuring equipment of this test report.



3.4.3 Test Procedures

1. The testing follows FCC KDB 789033 D02 General UNII Test Procedures New Rules v02r01. Section G) Unwanted emissions measurement.

(1) Procedure for Unwanted Emissions Measurements Below 1000MHz

- RBW = 120 kHz
- VBW = 300 kHz
- Detector = Peak
- Trace mode = max hold

(2) Procedure for Peak Unwanted Emissions Measurements Above 1000 MHz

- RBW = 1 MHz
- VBW \geq 3 MHz
- Detector = Peak
- Sweep time = auto
- Trace mode = max hold

(3) Procedures for Average Unwanted Emissions Measurements Above 1000MHz

- RBW = 1 MHz
- VBW = 10 Hz, when duty cycle is no less than 98 percent.
- VBW \geq 1/T, when duty cycle is less than 98 percent where T is the minimum transmission duration over which the transmitter is on and is transmitting at its maximum power control level for the tested mode of operation.



2. The EUT was placed on a turntable with 0.8 meter for frequency below 1GHz and 1.5 meter for frequency above 1GHz respectively above ground.
3. The EUT was set 3 meters from the interference receiving antenna which was mounted on the top of a variable height antenna tower.
4. The antenna is a broadband antenna and its height is adjusted between one meter and four meters above ground to find the maximum value of the field strength for both horizontal polarization and vertical polarization of the antenna.
5. For each suspected emission, the EUT was arranged to its worst case and then adjust the antenna tower (from 1 m to 4 m) and turntable (from 0 degree to 360 degrees) to find the maximum reading.
6. For testing below 1GHz, if the emission level of the EUT in peak mode was 3 dB lower than the limit specified, then peak values of EUT will be reported, otherwise, the emissions will be repeated one by one using the CISPR quasi-peak method and reported.
7. For testing above 1GHz, the emission level of the EUT in peak mode was 20dB lower than average limit (that means the emission level in average mode also complies with the limit in average mode), then peak values of EUT will be reported, otherwise, the emissions will be measured in average mode again and reported.

3.4.4 Test Setup

For radiated emissions below 30MHz

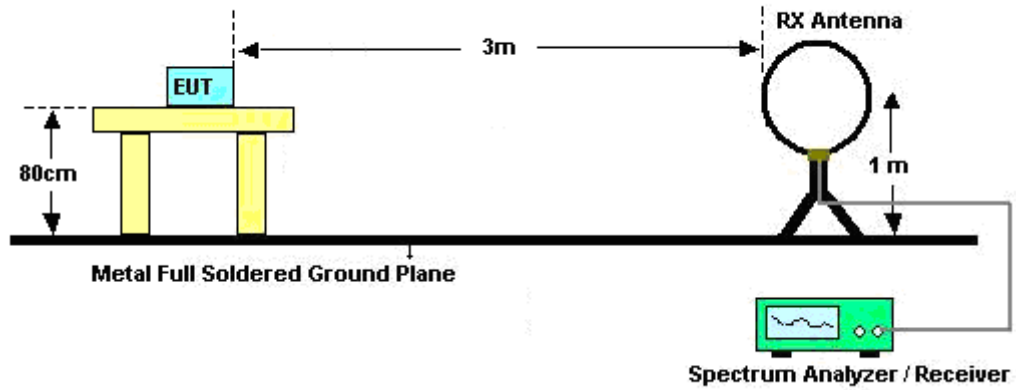

For radiated emissions from 30MHz to 1GHz

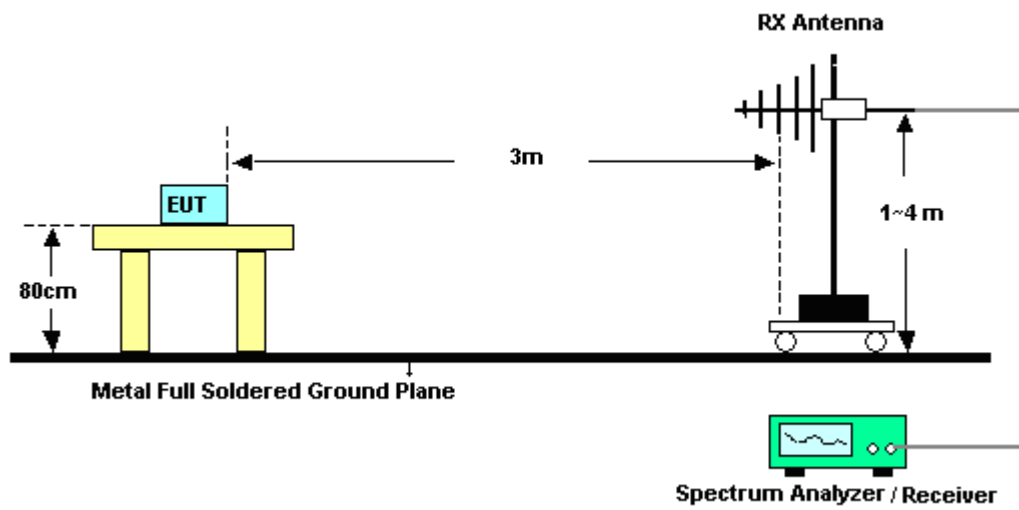

For radiated emissions above 1GHz

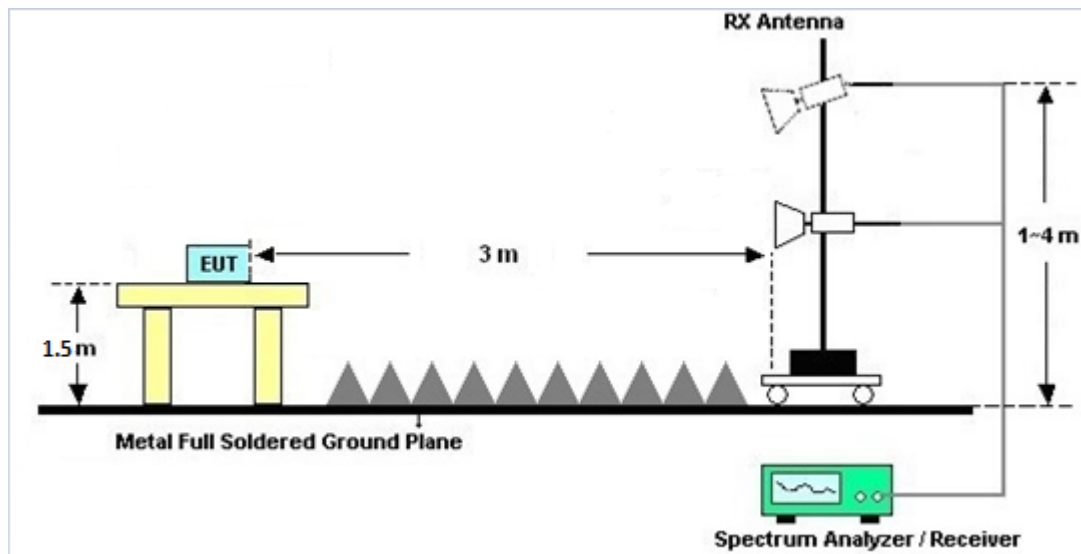

3.4.5 Test Results of Radiated Spurious Emissions (9 kHz ~ 30 MHz)

The low frequency, which started from 9 kHz to 30MHz, was pre-scanned and the result which was 20dB lower than the limit line was not reported.

There is a comparison data of both open-field test site and alternative test site - semi-Anechoic chamber according to 414788 D01 Radiated Test Site v01r01, and the result came out very similar.

3.4.6 Test Result of Radiated Spurious at Band Edges

Please refer to Appendix C and D.

3.4.7 Duty Cycle

Please refer to Appendix E.

3.4.8 Test Result of Radiated Spurious Emissions (30MHz ~ 10th Harmonic)

Please refer to Appendix C and D.



3.5 AC Conducted Emission Measurement

3.5.1 Limit of AC Conducted Emission

For equipment that is designed to be connected to the public utility (AC) power line, the radio frequency voltage that is conducted back onto the AC power line on any frequency or frequencies within the band 150 kHz to 30 MHz shall not exceed the limits in the following table.

Frequency of emission (MHz)	Conducted limit (dB μ V)	
	Quasi-peak	Average
0.15-0.5	66 to 56*	56 to 46*
0.5-5	56	46
5-30	60	50

*Decreases with the logarithm of the frequency.

3.5.2 Measuring Instruments

See list of measuring equipment of this test report.

3.5.3 Test Procedures

1. The EUT was placed 0.4 meter from the conducting wall of the shielding room was kept at least 80 centimeters from any other grounded conducting surface.
2. Connect EUT to the power mains through a line impedance stabilization network (LISN).
3. All the support units are connecting to the other LISN.
4. The LISN provides 50 ohm coupling impedance for the measuring instrument.
5. The FCC states that a 50 ohm, 50 microhenry LISN should be used.
6. Both sides of AC line were checked for maximum conducted interference.
7. The frequency range from 150 kHz to 30 MHz was searched.
8. Set the test-receiver system to Peak Detect Function and specified bandwidth with Maximum Hold Mode.

3.5.4 Test Setup

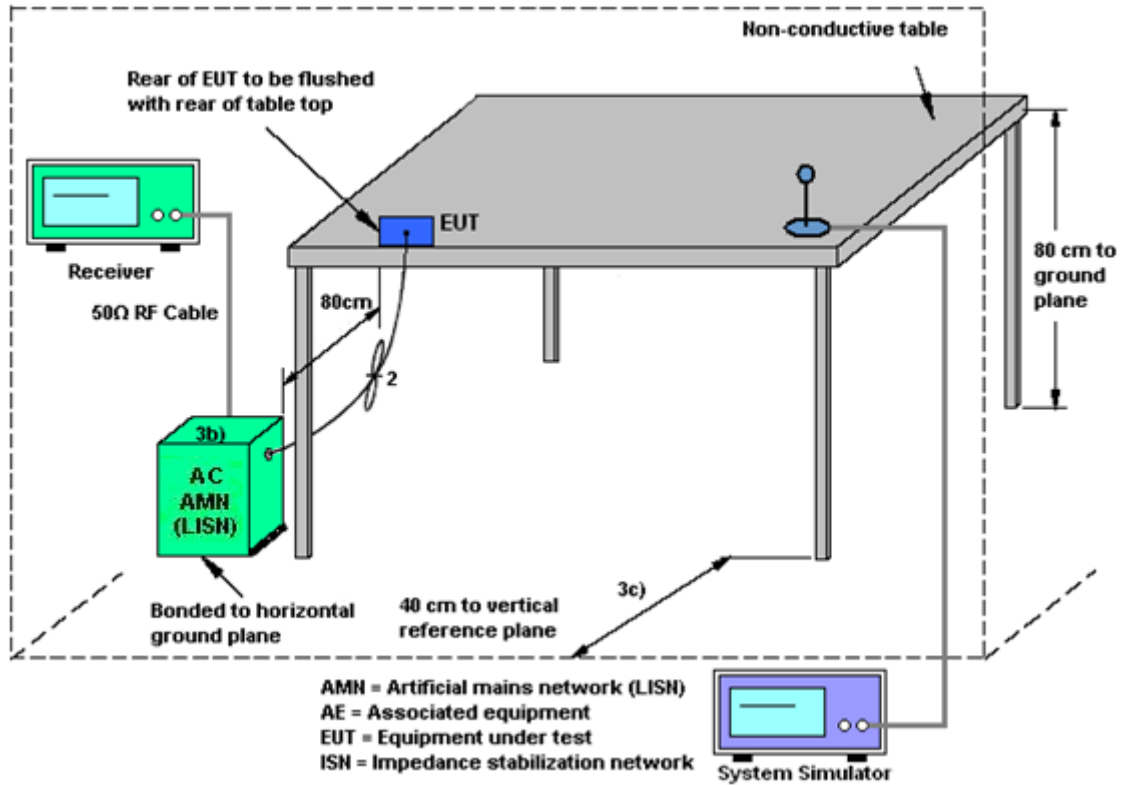

3.5.5 Test Result of AC Conducted Emission

Please refer to Appendix B.



3.6 Automatically Discontinue Transmission

3.6.1 Limit of Automatically Discontinue Transmission

The device shall automatically discontinue transmission in case of either absence of information to transmit or operational failure. These provisions are not intended to preclude the transmission of control or signaling information or the use of repetitive codes used by certain digital technologies to complete frame or burst intervals. Applicants shall include in their application for equipment authorization to describe how this requirement is met.

3.6.2 Measuring Instruments

See list of measuring equipment of this test report.

3.6.3 Test Result of Automatically Discontinue Transmission

While the EUT is not transmitting any information, the EUT can automatically discontinue transmission and become standby mode for power saving. The EUT can detect the controlling signal of ACK message transmitting from remote device and verify whether it shall resend or discontinue transmission.



3.7 Antenna Requirements

3.7.1 Standard Applicable

If transmitting antenna directional gain is greater than 6 dBi, both the peak transmit power and the peak power spectral density shall be reduced by the amount in dB that the directional gain of the antenna exceeds 6 dBi.

3.7.2 Antenna Anti-Replacement Construction

An embedded-in antenna design is used.

3.7.3 Antenna Gain

<CDD Modes >

FCC KDB 662911 D01 Multiple Transmitter Output v02r01

For CDD transmissions, directional gain is calculated as

Directional gain = GANT + Array Gain, where Array Gain is as follows.

For power spectral density (PSD) measurements on all devices,

Array Gain = 10 log(NANT/NSS=1) dB.

For power measurements on IEEE 802.11 devices,

Array Gain = 0 dB (i.e., no array gain) for NANT ≤ 4.

Directional gain may be calculated by using the formulas applicable to equal gain antennas with GANT set equal to the gain of the antenna having the highest gain;

The EUT supports CDD mode.

For power, the directional gain GANT is set equal to the antenna having the highest gain, i.e., F)2)f)i).

For PSD, the directional gain calculation is following F)2)f)ii) of KDB 662911 D01 v02r01.

The power and PSD limit should be modified if the directional gain of EUT is over 6 dBi,

The directional gain "DG" is calculated as following table.

<CDD Modes>						
			DG	DG	Power	PSD
			for	for	Limit	Limit
	Ant. 0	Ant. 1	Power	PSD	Reduction	Reduction
	(dBi)	(dBi)	(dBi)	(dBi)	(dB)	(dB)
Band I	2.60	3.00	3.00	5.81	0.00	0.00

Power limit reduction = Composite gain – 6dBi, (min = 0)

PSD limit reduction = Composite gain + PSD Array gain – 6dBi, (min = 0)



4 List of Measuring Equipment

Instrument	Brand Name	Model No.	Serial No.	Characteristics	Calibration Date	Test Date	Due Date	Remark
Loop Antenna	Rohde & Schwarz	HFH2-Z2	100488	9 kHz~30 MHz	Jan. 09, 2020	Aug. 14, 2020~ Sep. 08, 2020	Jan. 08, 2021	Radiation (03CH15-HY)
Bilog Antenna	TESEQ	CBL6111D&0 0800N1D01N- 06	41912&05	30MHz to 1GHz	Feb. 09, 2020	Aug. 14, 2020~ Sep. 08, 2020	Feb. 08, 2021	Radiation (03CH15-HY)
Amplifier	SONOMA	310N	363440	9kHz~1GHz	Dec. 27, 2019	Aug. 14, 2020~ Sep. 08, 2020	Dec. 26, 2020	Radiation (03CH15-HY)
Horn Antenna	SCHWARZBE CK	BBHA 9120 D	9120D-162 0	1-18GHz	Oct. 28, 2019	Aug. 14, 2020~ Sep. 08, 2020	Oct. 27, 2020	Radiation (03CH15-HY)
SHF-EHF Horn Antenna	SCHWARZBE CK	BBHA 9170	BBHA9170 584	18GHz- 40GHz	Dec. 10, 2019	Aug. 14, 2020~ Sep. 08, 2020	Dec. 09, 2020	Radiation (03CH15-HY)
Preamplifier	Jet-Power	JPA0118-55-3 03	171000180 0055006	1GHz~18GHz	May 07, 2020	Aug. 14, 2020~ Sep. 08, 2020	May 06, 2021	Radiation (03CH15-HY)
Preamplifier	Keysight	83017A	MY532701 95	1GHz~26.5GHz	Aug. 23, 2019	Aug. 14, 2020~ Aug. 21, 2020	Aug. 22, 2020	Radiation (03CH15-HY)
Preamplifier	Keysight	83017A	MY532701 95	1GHz~26.5GHz	Aug. 21, 2020	Aug. 21, 2020~ Sep. 08, 2020	Aug. 20, 2021	Radiation (03CH15-HY)
Preamplifier	EMEC	EM18G40G	060715	18GHz ~ 40GHz	Dec. 13, 2019	Aug. 14, 2020~ Sep. 08, 2020	Dec. 12, 2020	Radiation (03CH15-HY)
EMI Test Receiver	Keysight	N9038A(MXE)	MY541300 85	20MHz~8.4GHz	Nov. 01, 2019	Aug. 14, 2020~ Sep. 08, 2020	Oct. 31, 2020	Radiation (03CH15-HY)
Spectrum Analyzer	Agilent	E4446A	MY501801 36	3Hz~44GHz	May 04, 2020	Aug. 14, 2020~ Sep. 08, 2020	May 03, 2021	Radiation (03CH15-HY)
Antenna Mast	ChainTek	MBS-520-1	N/A	1m~4m	N/A	Aug. 14, 2020~ Sep. 08, 2020	N/A	Radiation (03CH15-HY)
Turn Table	ChainTek	T-200-S-1	N/A	0~360 Degree	N/A	Aug. 14, 2020~ Sep. 08, 2020	N/A	Radiation (03CH15-HY)
Software	Audix	E3 6.2009-8-24(k 5)	RK-00045 1	N/A	N/A	Aug. 14, 2020~ Sep. 08, 2020	N/A	Radiation (03CH15-HY)
RF Cable	HUBER + SUHNER	SUCOFLEX 104	MY9837/4 PE	9kHz~30MHz	Mar. 12, 2020	Aug. 14, 2020~ Sep. 08, 2020	Mar. 11, 2021	Radiation (03CH15-HY)
RF Cable	HUBER + SUHNER	SUCOFLEX 104	MY36980/ 4	30M-18G	Apr. 14, 2020	Aug. 14, 2020~ Sep. 08, 2020	Apr. 13, 2021	Radiation (03CH15-HY)
RF Cable	HUBER + SUHNER	SUCOFLEX 104	MY9838/4 PE	30M-18G	Apr. 14, 2020	Aug. 14, 2020~ Sep. 08, 2020	Apr. 13, 2021	Radiation (03CH15-HY)
RF Cable	HUBER + SUHNER	SUCOFLEX 104	MY37710/ 4	30M-18G	Apr. 17, 2020	Aug. 14, 2020~ Sep. 08, 2020	Apr. 16, 2021	Radiation (03CH15-HY)
RF Cable	HUBER + SUHNER	SUCOFLEX 102	505134/2	30MHz-40GHz	Feb. 25, 2020	Aug. 14, 2020~ Sep. 08, 2020	Feb. 24, 2021	Radiation (03CH15-HY)
RF Cable	HUBER + SUHNER	SUCOFLEX 102	800740/2	30MHz-40GHz	Feb. 25, 2020	Aug. 14, 2020~ Sep. 08, 2020	Feb. 24, 2021	Radiation (03CH15-HY)
Filter	Wainwright	WLK4-1000-1 530-8000-40S S	SN4	1.53G Low Pass	Jul. 03, 2020	Aug. 14, 2020~ Sep. 08, 2020	Jul. 02, 2021	Radiation (03CH15-HY)
Filter	Wainwright	WHKX8-5872. 5-6750-18000 -40ST	SN6	6.75GHz High Pass Filter	Jul. 03, 2020	Aug. 14, 2020~ Sep. 08, 2020	Jul. 02, 2021	Radiation (03CH15-HY)



Instrument	Brand Name	Model No.	Serial No.	Characteristics	Calibration Date	Test Date	Due Date	Remark
Hygrometer	Testo	608-H1	34893241	N/A	Mar. 02, 2020	Jul. 25, 2020~ Aug. 26, 2020	Mar. 01, 2021	Conducted (TH05-HY)
Power Sensor	DARE	RPR3006W	16I00054S NO10	10MHz~6GHz	Dec. 23, 2019	Jul. 25, 2020~ Aug. 26, 2020	Dec. 22, 2020	Conducted (TH05-HY)
Signal Analyzer	Rohde & Schwarz	FSV40	101397	10Hz~40GHz	Nov. 15, 2019	Jul. 25, 2020~ Aug. 26, 2020	Nov. 14, 2020	Conducted (TH05-HY)
Spectrum Analyzer	Rohde & Schwarz	FSP40	100055	9kHz-40GHz	Dec. 30, 2019	Jul. 25, 2020~ Aug. 26, 2020	Dec. 29, 2020	Conducted (TH05-HY)
Programmable Power Supply	GW Instek	GPP-2323	GES90603 7	0V~64V ; 0A~6A	Dec. 13, 2019	Jul. 25, 2020~ Aug. 26, 2020	Dec. 12, 2020	Conducted (TH05-HY)
Switch Control Manframe	EM Electronics	EMSW18SE	SW200302	N/A	Mar. 17, 2020	Jul. 25, 2020~ Aug. 26, 2020	Mar. 16, 2021	Conducted (TH05-HY)
AC Power Source	ChainTek	APC-1000W	N/A	N/A	N/A	Jul. 23, 2020	N/A	Conduction (CO05-HY)
EMI Test Receiver	Rohde & Schwarz	ESR3	102388	9kHz~3.6GHz	Nov. 15, 2019	Jul. 23, 2020	Nov. 14, 2020	Conduction (CO05-HY)
Hygrometer	Testo	608-H1	34913912	N/A	Nov. 07, 2019	Jul. 23, 2020	Nov. 06, 2020	Conduction (CO05-HY)
LISN	Rohde & Schwarz	ENV216	100081	9kHz~30MHz	Nov. 15, 2019	Jul. 23, 2020	Nov. 14, 2020	Conduction (CO05-HY)
Software	Rohde & Schwarz	EMC32 V10.30	N/A	N/A	N/A	Jul. 23, 2020	N/A	Conduction (CO05-HY)
LF Cable	HUBER + SUHNER	RG-214/U	LF01	N/A	Jan. 02, 2020	Jul. 23, 2020	Jan. 01, 2021	Conduction (CO05-HY)
Pulse Limiter	Rohde & Schwarz	ESH3-Z2	100851	N/A	Jan. 02, 2020	Jul. 23, 2020	Jan. 01, 2021	Conduction (CO05-HY)



5 Uncertainty of Evaluation

Uncertainty of Conducted Emission Measurement (150kHz ~ 30MHz)

Measuring Uncertainty for a Level of Confidence of 95% ($U = 2Uc(y)$)	2.3
---	-----

Uncertainty of Radiated Emission Measurement (30 MHz ~ 1000 MHz)

Measuring Uncertainty for a Level of Confidence of 95% ($U = 2Uc(y)$)	5.0
---	-----

Uncertainty of Radiated Emission Measurement (1000 MHz ~ 18000 MHz)

Measuring Uncertainty for a Level of Confidence of 95% ($U = 2Uc(y)$)	5.4
---	-----

Uncertainty of Radiated Emission Measurement (18000 MHz ~ 40000 MHz)

Measuring Uncertainty for a Level of Confidence of 95% ($U = 2Uc(y)$)	5.0
---	-----

Appendix A. Test Result of Conducted Test Items

Test Engineer:	Sylvia Li / Kai Liao	Temperature:	23.5 ~ 24.3	°C
Test Date:	2020/07/25~2020/08/26	Relative Humidity:	49 ~ 55	%

TEST RESULTS DATA
26dB and 99% OBW

Band I MIMO													
Mod.	Data Rate	NTX	CH.	Freq. (MHz)	99% Bandwidth (MHz)		26 dB Bandwidth (MHz)		IC 99% Bandwidth Power Limit (dBm)		IC 99% Bandwidth EIRP Limit (dBm)		Note
					Ant 0	Ant 1	Ant 0	Ant 1	Ant 0	Ant 1	Ant 0	Ant 1	
11a	6Mbps	2	36	5180	16.38	16.38	20.20	20.70	-	-	22.14	22.14	
11a	6Mbps	2	44	5220	16.38	16.38	20.65	20.75	-	-	22.14	22.14	
11a	6Mbps	2	48	5240	16.38	16.38	20.60	20.69	-	-	22.14	22.14	

TEST RESULTS DATA
Average Power Table

FCC Band I single antenna													
Mod.	Data Rate	NTX	CH.	Freq. (MHz)	Average Conducted Power (dBm)			FCC Conducted Power Limit (dBm)		DG (dBi)			Pass/Fail
					Ant 0	Ant 1	SUM	Ant 0	Ant 1	Ant 0	Ant 1		
11a	6Mbps	1	36	5180	11.9	12.6		24.00	24.00	2.60	3.00		Pass
11a	6Mbps	1	44	5220	11.8	12.3		24.00	24.00	2.60	3.00		Pass
11a	6Mbps	1	48	5240	11.8	12.5		24.00	24.00	2.60	3.00		Pass
HT20	MCS0	1	36	5180	11.6	12.4		24.00	24.00	2.60	3.00		Pass
HT20	MCS0	1	44	5220	11.6	12.1		24.00	24.00	2.60	3.00		Pass
HT20	MCS0	1	48	5240	11.7	12.3		24.00	24.00	2.60	3.00		Pass
HT40	MCS0	1	38	5190	11.6	12.2		24.00	24.00	2.60	3.00		Pass
HT40	MCS0	1	46	5230	11.6	12.1		24.00	24.00	2.60	3.00		Pass
VHT20	MCS0	1	36	5180	11.5	12.3		24.00	24.00	2.60	3.00		Pass
VHT20	MCS0	1	44	5220	11.5	12.0		24.00	24.00	2.60	3.00		Pass
VHT20	MCS0	1	48	5240	11.6	12.2		24.00	24.00	2.60	3.00		Pass
VHT40	MCS0	1	38	5190	11.6	12.1		24.00	24.00	2.60	3.00		Pass
VHT40	MCS0	1	46	5230	11.6	11.9		24.00	24.00	2.60	3.00		Pass
VHT80	MCS0	1	42	5210	11.6	12.2		24.00	24.00	2.60	3.00		Pass

FCC Band I MIMO													
Mod.	Data Rate	NTX	CH.	Freq. (MHz)	Average Conducted Power (dBm)			FCC Conducted Power Limit (dBm)		DG (dBi)			Pass/Fail
					Ant 0	Ant 1	SUM	Ant 0	Ant 1	Ant 0	Ant 1		
11a	6Mbps	2	36	5180	13.2	12.1	15.7	24.00		3.00			Pass
11a	6Mbps	2	44	5220	13.0	11.9	15.5	24.00		3.00			Pass
11a	6Mbps	2	48	5240	13.3	12.3	15.8	24.00		3.00			Pass
HT20	MCS0	2	36	5180	13.4	12.0	15.8	24.00		3.00			Pass
HT20	MCS0	2	44	5220	13.2	11.9	15.6	24.00		3.00			Pass
HT20	MCS0	2	48	5240	13.2	11.9	15.6	24.00		3.00			Pass
HT40	MCS0	2	38	5190	13.3	12.1	15.8	24.00		3.00			Pass
HT40	MCS0	2	46	5230	13.1	11.7	15.5	24.00		3.00			Pass
VHT20	MCS0	2	36	5180	13.4	11.9	15.7	24.00		3.00			Pass
VHT20	MCS0	2	44	5220	13.1	11.8	15.5	24.00		3.00			Pass
VHT20	MCS0	2	48	5240	13.1	11.9	15.6	24.00		3.00			Pass
VHT40	MCS0	2	38	5190	13.1	11.9	15.6	24.00		3.00			Pass
VHT40	MCS0	2	46	5230	13.1	11.8	15.5	24.00		3.00			Pass
VHT80	MCS0	2	42	5210	12.9	11.8	15.4	24.00		3.00			Pass

TEST RESULTS DATA
Power Spectral Density

FCC Band I MIMO												
Mod.	Data Rate	NTX	CH.	Freq. (MHz)	Average Power Density (dBm/MHz)			Average PSD Limit (dBm/MHz)		DG (dBi)		Pass /Fail
					Ant 0	Ant 1	SUM	Ant 0	Ant 1	Ant 0	Ant 1	
11a	6Mbps	2	36	5180			5.37	11.00	5.81		Pass	
11a	6Mbps	2	44	5220			5.15	11.00	5.81		Pass	
11a	6Mbps	2	48	5240			5.44	11.00	5.81		Pass	

TEST RESULTS DATA
26dB and 99% OBW

Band I MIMO														
Mod.	Data Rate	N _{TX}	CH.	Freq. (MHz)	RU Config	99% Bandwidth (MHz)		26 dB Bandwidth (MHz)		IC 99% Bandwidth Power Limit (dBm)		IC 99% Bandwidth EIRP Limit (dBm)		Note
						Ant 0	Ant 1	Ant 0	Ant 1	Ant 0	Ant 1	Ant 0	Ant 1	
HE20	MCS0	2	36	5180	Full	18.88	18.88	22.05	22.10	-	-	22.76	22.76	
HE20	MCS0	2	44	5220	Full	18.88	18.88	22.35	22.00	-	-	22.76	22.76	
HE20	MCS0	2	48	5240	Full	18.88	18.88	22.05	21.90	-	-	22.76	22.76	
HE40	MCS0	2	38	5190	Full	37.86	37.86	41.58	41.31	-	-	23.01	23.01	
HE40	MCS0	2	46	5230	Full	37.86	37.76	41.31	41.22	-	-	23.01	23.01	
HE80	MCS0	2	42	5210	Full	77.92	77.92	82.08	82.40	-	-	23.01	23.01	

TEST RESULTS DATA
Average Power Table

FCC Band I single antenna													
Mod.	Data Rate	NTX	CH.	Freq. (MHz)	RU Config	Average Conducted Power (dBm)			FCC Conducted Power Limit (dBm)		DG (dBi)		Pass/Fail
						Ant 0	Ant 1	SUM	Ant 0	Ant 1	Ant 0	Ant 1	
HE20	MCS0	1	36	5180	Full	11.8	12.5		24.00	24.00	2.60	3.00	Pass
HE20	MCS0	1	36	5180	26/0	3.7	4.1		24.00	24.00	2.60	3.00	Pass
HE20	MCS0	1	36	5180	52/37	6.8	6.3		24.00	24.00	2.60	3.00	Pass
HE20	MCS0	1	36	5180	106/53	10.4	9.5		24.00	24.00	2.60	3.00	Pass
HE20	MCS0	1	44	5220	Full	11.7	12.2		24.00	24.00	2.60	3.00	Pass
HE20	MCS0	1	44	5220	26/4	4.6	4.0		24.00	24.00	2.60	3.00	Pass
HE20	MCS0	1	48	5240	Full	11.8	12.4		24.00	24.00	2.60	3.00	Pass
HE20	MCS0	1	48	5240	26/8	4.0	3.3		24.00	24.00	2.60	3.00	Pass
HE20	MCS0	1	48	5240	52/40	7.2	6.4		24.00	24.00	2.60	3.00	Pass
HE20	MCS0	1	48	5240	106/54	10.0	9.3		24.00	24.00	2.60	3.00	Pass
HE40	MCS0	1	38	5190	Full	11.8	12.5		24.00	24.00	2.60	3.00	Pass
HE40	MCS0	1	38	5190	242/61	10.6	10.1		24.00	24.00	2.60	3.00	Pass
HE40	MCS0	1	46	5230	Full	11.6	12.3		24.00	24.00	2.60	3.00	Pass
HE40	MCS0	1	46	5230	242/62	10.7	10.1		24.00	24.00	2.60	3.00	Pass
HE80	MCS0	1	42	5210	Full	11.6	12.6		24.00	24.00	2.60	3.00	Pass
HE80	MCS0	1	42	5210	484/65	10.50	9.90		24.00	24.00	2.60	3.00	Pass
HE80	MCS0	1	42	5210	484/66	10.30	9.30		24.00	24.00	2.60	3.00	Pass

FCC Band I MIMO													
Mod.	Data Rate	NTX	CH.	Freq. (MHz)	RU Config	Average Conducted Power (dBm)			FCC Conducted Power Limit (dBm)		DG (dBi)		Pass/Fail
						Ant 0	Ant 1	SUM	Ant 0	Ant 1	Ant 0	Ant 1	
HE20	MCS0	2	36	5180	Full	13.4	12.2	15.9	24.00	24.00	3.00	3.00	Pass
HE20	MCS0	2	36	5180	26/0	3.8	4.2	7.0	24.00	24.00	3.00	3.00	Pass
HE20	MCS0	2	36	5180	52/37	6.9	6.4	9.7	24.00	24.00	3.00	3.00	Pass
HE20	MCS0	2	36	5180	106/53	10.5	9.6	13.1	24.00	24.00	3.00	3.00	Pass
HE20	MCS0	2	44	5220	Full	13.3	12.0	15.7	24.00	24.00	3.00	3.00	Pass
HE20	MCS0	2	44	5220	26/4	4.7	4.1	7.4	24.00	24.00	3.00	3.00	Pass
HE20	MCS0	2	48	5240	Full	13.4	12.1	15.8	24.00	24.00	3.00	3.00	Pass
HE20	MCS0	2	48	5240	26/8	4.1	3.4	6.8	24.00	24.00	3.00	3.00	Pass
HE20	MCS0	2	48	5240	52/40	7.3	6.5	9.9	24.00	24.00	3.00	3.00	Pass
HE20	MCS0	2	48	5240	106/54	10.1	9.4	12.8	24.00	24.00	3.00	3.00	Pass
HE40	MCS0	2	38	5190	Full	13.5	12.3	16.0	24.00	24.00	3.00	3.00	Pass
HE40	MCS0	2	38	5190	242/61	10.7	10.2	13.5	24.00	24.00	3.00	3.00	Pass
HE40	MCS0	2	46	5230	Full	13.5	12.1	15.9	24.00	24.00	3.00	3.00	Pass
HE40	MCS0	2	46	5230	242/62	10.8	10.1	13.5	24.00	24.00	3.00	3.00	Pass
HE80	MCS0	2	42	5210	Full	13.4	12.2	15.9	24.00	24.00	3.00	3.00	Pass
HE80	MCS0	2	42	5210	484/65	10.60	10.00	13.32	24.00	24.00	3.00	3.00	Pass
HE80	MCS0	2	42	5210	484/66	10.40	9.40	12.94	24.00	24.00	3.00	3.00	Pass

TEST RESULTS DATA
Power Spectral Density

FCC Band I MIMO													
Mod.	Data Rate	NTX	CH.	Freq. (MHz)	RU Config	Average Power Density (dBm/MHz)			Average PSD Limit (dBm/MHz)		DG (dBi)		Pass /Fail
						Ant 0	Ant 1	SUM	Ant 0	Ant 1	Ant 0	Ant 1	
HE20	MCS0	2	36	5180	Full			5.39	11.00	5.81		Pass	
HE20	MCS0	2	36	5180	26/0			5.04	11.00	5.81		Pass	
HE20	MCS0	2	36	5180	52/37			4.88	11.00	5.81		Pass	
HE20	MCS0	2	36	5180	106/53			5.11	11.00	5.81		Pass	
HE20	MCS0	2	44	5220	Full			5.17	11.00	5.81		Pass	
HE20	MCS0	2	44	5220	26/4			4.50	11.00	5.81		Pass	
HE20	MCS0	2	48	5240	Full			5.64	11.00	5.81		Pass	
HE20	MCS0	2	48	5240	26/8			4.86	11.00	5.81		Pass	
HE20	MCS0	2	48	5240	52/40			5.03	11.00	5.81		Pass	
HE20	MCS0	2	48	5240	106/54			4.96	11.00	5.81		Pass	
HE40	MCS0	2	38	5190	Full			2.45	11.00	5.81		Pass	
HE40	MCS0	2	38	5190	242/61			1.93	11.00	5.81		Pass	
HE40	MCS0	2	46	5230	Full			2.33	11.00	5.81		Pass	
HE40	MCS0	2	46	5230	242/62			2.11	11.00	5.81		Pass	
HE80	MCS0	2	42	5210	Full			-0.74	11.00	5.81		Pass	
HE80	MCS0	2	42	5210	484/65			-0.99	11.00	5.81		Pass	
HE80	MCS0	2	42	5210	484/66			-1.24	11.00	5.81		Pass	



Appendix B. AC Conducted Emission Test Results

Test Engineer :	Howard Huang	Temperature :	23~25°C
		Relative Humidity :	42~50%

EUT Information

Report NO : 041657
 Test Mode : Mode 1
 Test Voltage : 120Vac/60Hz
 Phase : Line

Full Spectrum

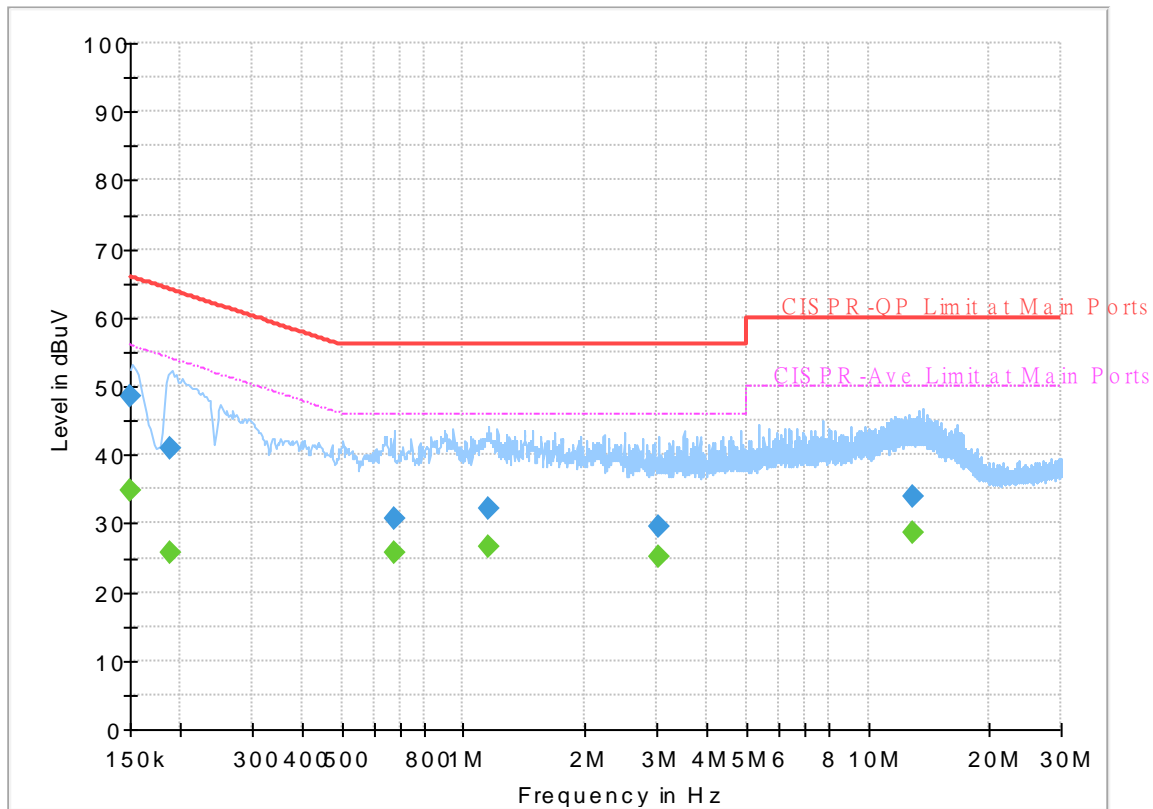

Final Result

Frequency (MHz)	QuasiPeak (dBuV)	CAverage (dBuV)	Limit (dBuV)	Margin (dB)	Line	Filter	Corr. (dB)
0.150000	48.66	---	66.00	17.34	L1	OFF	19.6
0.150000	---	34.94	56.00	21.06	L1	OFF	19.6
0.189420	40.84	---	64.06	23.22	L1	OFF	19.6
0.189420	---	25.59	54.06	28.47	L1	OFF	19.6
0.678750	30.72	---	56.00	25.28	L1	OFF	19.6
0.678750	---	25.60	46.00	20.40	L1	OFF	19.6
1.153950	32.25	---	56.00	23.75	L1	OFF	19.6
1.153950	---	26.74	46.00	19.26	L1	OFF	19.6
3.029190	29.54	---	56.00	26.46	L1	OFF	19.7
3.029190	---	25.29	46.00	20.71	L1	OFF	19.7
12.871500	33.79	---	60.00	26.21	L1	OFF	20.2
12.871500	---	28.51	50.00	21.49	L1	OFF	20.2

EUT Information

Report NO : 041657
 Test Mode : Mode 1
 Test Voltage : 120Vac/60Hz
 Phase : Neutral

Full Spectrum

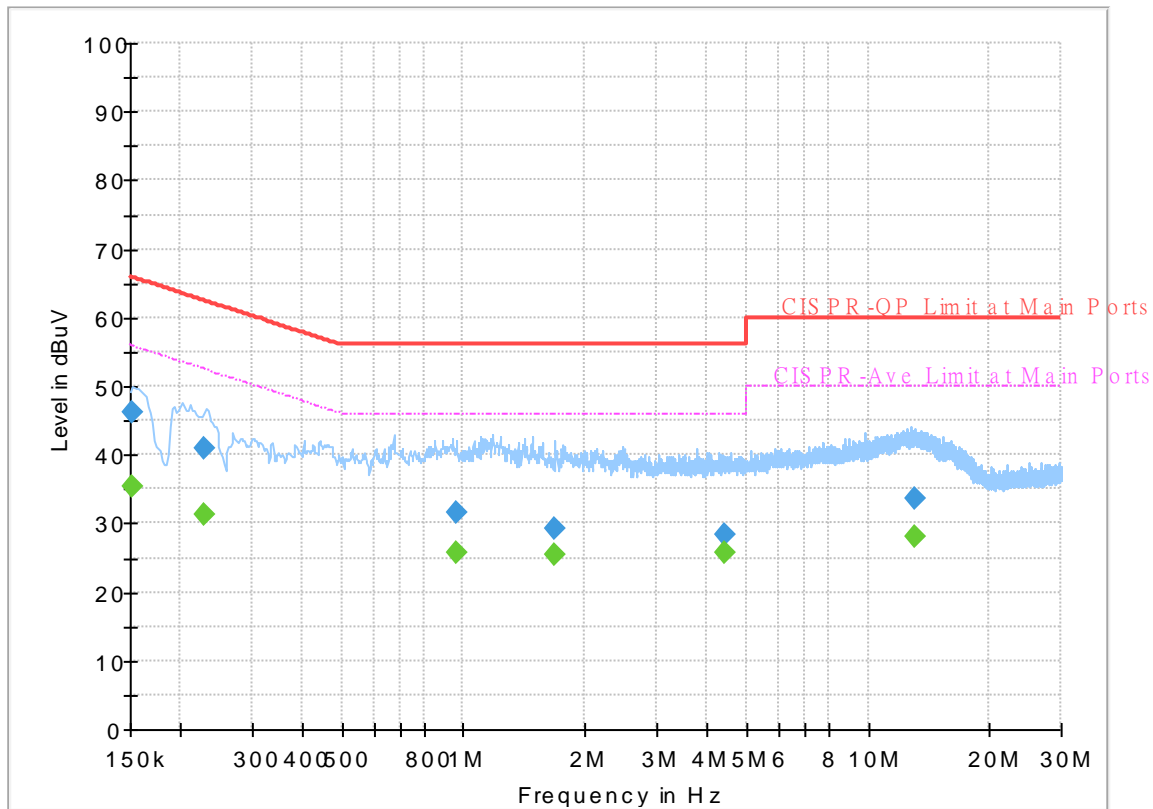

Final_Result

Frequency (MHz)	QuasiPeak (dBuV)	CAverage (dBuV)	Limit (dBuV)	Margin (dB)	Line	Filter	Corr. (dB)
0.151620	---	35.26	55.91	20.65	N	OFF	19.5
0.151620	46.18	---	65.91	19.73	N	OFF	19.5
0.228660	---	31.21	52.50	21.29	N	OFF	19.5
0.228660	40.80	---	62.50	21.70	N	OFF	19.5
0.962700	---	25.86	46.00	20.14	N	OFF	19.6
0.962700	31.67	---	56.00	24.33	N	OFF	19.6
1.675590	---	25.42	46.00	20.58	N	OFF	19.6
1.675590	29.14	---	56.00	26.86	N	OFF	19.6
4.402500	---	25.67	46.00	20.33	N	OFF	19.6
4.402500	28.36	---	56.00	27.64	N	OFF	19.6
13.043130	---	28.14	50.00	21.86	N	OFF	19.9
13.043130	33.63	---	60.00	26.37	N	OFF	19.9



Appendix C. Radiated Spurious Emission

Test Engineer :	Leo Lee, Mancy Chou and Bigshow Wang	Temperature :	22.1~24°C
		Relative Humidity :	45~59%

Band 1 - 5150~5250MHz
WIFI 802.11a (Band Edge @ 3m)

WIFI	Note	Frequency	Level	Over	Limit	Read	Antenna	Path	Preamp	Ant	Table	Peak	Pol.	
Ant.				Limit	Line	Level	Factor	Loss	Factor	Pos	Pos	Avg.		
0+1		(MHz)	(dBµV/m)	(dB)	(dBµV/m)	(dBµV)	(dB/m)	(dB)	(dB)	(cm)	(deg)	(P/A)	(H/V)	
802.11a CH 36 5180MHz		5126.88	52.39	-21.61	74	39.89	32.05	10.46	30.01	100	297	P	H	
		5150	42.33	-11.67	54	29.75	32.1	10.49	30.01	100	297	A	H	
	*	5180	108.27	-	-	95.82	31.92	10.54	30.01	100	297	P	H	
	*	5180	100.41	-	-	87.96	31.92	10.54	30.01	100	297	A	H	
													H	
														H
			5148.2	52.62	-21.38	74	40.04	32.1	10.49	30.01	371	298	P	V
			5149.24	42.05	-11.95	54	29.47	32.1	10.49	30.01	371	298	A	V
	*		5180	106.73	-	-	94.28	31.92	10.54	30.01	371	298	P	V
	*		5180	99.24	-	-	86.79	31.92	10.54	30.01	371	298	A	V
														V
														V
802.11a CH 44 5220MHz		5140.92	52.23	-21.77	74	39.68	32.08	10.48	30.01	100	297	P	H	
		5091.78	42.12	-11.88	54	29.74	31.98	10.41	30.01	100	297	A	H	
	*	5220	107.11	-	-	94.86	31.68	10.58	30.01	100	297	P	H	
	*	5220	99.31	-	-	87.06	31.68	10.58	30.01	100	297	A	H	
			5371.52	52.04	-21.96	74	39.86	31.53	10.65	30	100	297	P	H
			5405.68	41.96	-12.04	54	29.59	31.7	10.67	30	100	297	A	H
			5054.86	51.88	-22.12	74	39.64	31.91	10.35	30.02	345	294	P	V
			5100.88	41.86	-12.14	54	29.45	32	10.42	30.01	345	294	A	V
	*		5220	106.23	-	-	93.98	31.68	10.58	30.01	345	294	P	V
	*		5220	98.66	-	-	86.41	31.68	10.58	30.01	345	294	A	V
			5440.12	51.84	-22.16	74	39.42	31.7	10.71	29.99	345	294	P	V
			5416.6	41.76	-12.24	54	29.38	31.7	10.68	30	345	294	A	V



802.11a CH 48 5240MHz		5122.72	53.35	-20.65	74	40.86	32.05	10.45	30.01	100	296	P	H
		5091.78	42.93	-11.07	54	30.55	31.98	10.41	30.01	100	296	A	H
	*	5240	111.06	-	-	98.92	31.56	10.59	30.01	100	296	P	H
	*	5240	103.26	-	-	91.12	31.56	10.59	30.01	100	296	A	H
		5390.84	52.4	-21.6	74	40.09	31.65	10.66	30	100	296	P	H
		5399.52	42.37	-11.63	54	30.01	31.7	10.66	30	100	296	A	H
		5138.32	52.26	-21.74	74	39.71	32.08	10.48	30.01	340	295	P	V
		5105.04	42.27	-11.73	54	29.84	32.01	10.43	30.01	340	295	A	V
	*	5240	110.34	-	-	98.2	31.56	10.59	30.01	340	295	P	V
	*	5240	102.59	-	-	90.45	31.56	10.59	30.01	340	295	A	V
		5432	52.42	-21.58	74	40.01	31.7	10.7	29.99	340	295	P	V
		5403.72	42.03	-11.97	54	29.66	31.7	10.67	30	340	295	A	V
Remark	1. No other spurious found. 2. All results are PASS against Peak and Average limit line.												



**Band 1 5150~5250MHz
WIFI 802.11a (Harmonic @ 3m)**

WIFI Ant. 0+1	Note	Frequency (MHz)	Level (dBµV/m)	Over Limit (dB)	Limit Line (dBµV/m)	Read Level (dBµV)	Antenna Factor (dB/m)	Path Loss (dB)	Preamp Factor (dB)	Ant Pos (cm)	Table Pos (deg)	Peak Avg. (P/A)	Pol. (H/V)
802.11a CH 36 5180MHz		10360	49.03	-19.17	68.2	55.62	39.9	14.41	60.9	100	0	P	H
		15540	47.27	-26.73	74	54.7	38	17.28	62.71	100	0	P	H
													H
													H
		10360	48.57	-19.63	68.2	55.16	39.9	14.41	60.9	100	0	P	V
		15540	46.92	-27.08	74	54.35	38	17.28	62.71	100	0	P	V
													V
													V
802.11a CH 44 5220MHz		10440	48.25	-19.95	68.2	54.76	40.1	14.41	61.02	100	0	P	H
		15660	46.73	-27.27	74	53.94	37.58	17.34	62.13	100	0	P	H
													H
													H
		10440	48.1	-20.1	68.2	54.61	40.1	14.41	61.02	100	0	P	V
		15660	46.43	-27.57	74	53.64	37.58	17.34	62.13	100	0	P	V
													V
													V
802.11a CH 48 5240MHz		10480	47.37	-20.83	68.2	53.93	40.1	14.41	61.07	100	0	P	H
		15720	45.94	-28.06	74	52.95	37.46	17.37	61.84	100	0	P	H
													H
													H
		10480	48.56	-19.64	68.2	55.12	40.1	14.41	61.07	100	0	P	V
		15720	46.15	-27.85	74	53.16	37.46	17.37	61.84	100	0	P	V
													V
													V
Remark	1. No other spurious found. 2. All results are PASS against Peak and Average limit line.												



Band 1 5150~5250MHz
WIFI 802.11ax HE20 Full (Band Edge @ 3m)

WIFI Ant. 0+1	Note	Frequency (MHz)	Level (dBμV/m)	Over Limit (dB)	Limit Line (dBμV/m)	Read Level (dBμV)	Antenna Factor (dB/m)	Path Loss (dB)	Preamp Factor (dB)	Ant Pos (cm)	Table Pos (deg)	Peak Avg. (P/A)	Pol. (H/V)	
802.11ax HE20 Full CH 36 5180MHz		5143	51.95	-22.05	74	39.39	32.09	10.48	30.01	100	298	P	H	
		5150	42.81	-11.19	54	30.23	32.1	10.49	30.01	100	298	A	H	
	*	5180	110.98	-	-	98.53	31.92	10.54	30.01	100	298	P	H	
	*	5180	100.55	-	-	88.1	31.92	10.54	30.01	100	298	A	H	
													H	
														H
			5067.86	52.53	-21.47	74	40.24	31.94	10.37	30.02	347	136	P	V
			5150	42.2	-11.8	54	29.62	32.1	10.49	30.01	347	136	A	V
		*	5180	109.83	-	-	97.38	31.92	10.54	30.01	347	136	P	V
		*	5180	99.13	-	-	86.68	31.92	10.54	30.01	347	136	A	V
													V	
													V	
802.11ax HE20 Full CH 44 5220MHz		5002.08	52.39	-21.61	74	40.42	31.71	10.28	30.02	100	312	P	H	
		5099.84	42.04	-11.96	54	29.63	32	10.42	30.01	100	312	A	H	
		* 5220	110.4	-	-	98.15	31.68	10.58	30.01	100	312	P	H	
		* 5220	99.57	-	-	87.32	31.68	10.58	30.01	100	312	A	H	
			5406.8	51.67	-22.33	74	39.3	31.7	10.67	30	100	312	P	H
			5404	41.87	-12.13	54	29.5	31.7	10.67	30	100	312	A	H
			5057.46	52.36	-21.64	74	40.11	31.91	10.36	30.02	346	131	P	V
			5106.6	41.99	-12.01	54	29.56	32.01	10.43	30.01	346	131	A	V
		*	5220	109.51	-	-	97.26	31.68	10.58	30.01	346	131	P	V
		*	5220	98.62	-	-	86.37	31.68	10.58	30.01	346	131	A	V
		5411.56	52.74	-21.26	74	40.37	31.7	10.67	30	346	131	P	V	
		5417.44	41.83	-12.17	54	29.44	31.7	10.68	29.99	346	131	A	V	



802.11ax HE20 Full CH 48 5240MHz		5080.34	53.46	-20.54	74	41.13	31.96	10.39	30.02	100	294	P	H
		5094.12	42.95	-11.05	54	30.56	31.99	10.41	30.01	100	294	A	H
	*	5240	113.65	-	-	101.51	31.56	10.59	30.01	100	294	P	H
	*	5240	102.56	-	-	90.42	31.56	10.59	30.01	100	294	A	H
		5382.44	52.12	-21.88	74	39.88	31.59	10.65	30	100	294	P	H
		5402.6	42.32	-11.68	54	29.96	31.7	10.66	30	100	294	A	H
		5106.86	52.83	-21.17	74	40.4	32.01	10.43	30.01	345	134	P	V
		5092.82	42.21	-11.79	54	29.82	31.99	10.41	30.01	345	134	A	V
	*	5240	112.49	-	-	100.35	31.56	10.59	30.01	345	134	P	V
	*	5240	101.85	-	-	89.71	31.56	10.59	30.01	345	134	A	V
		5366.48	51.24	-22.76	74	39.09	31.5	10.65	30	345	134	P	V
		5400.92	41.89	-12.11	54	29.53	31.7	10.66	30	345	134	A	V
Remark	1. No other spurious found. 2. All results are PASS against Peak and Average limit line.												



Band 1 5150~5250MHz

WIFI 802.11ax HE20 Full (Harmonic @ 3m)

WIFI Ant. 0+1	Note	Frequency (MHz)	Level (dBμV/m)	Over Limit (dB)	Limit Line (dBμV/m)	Read Level (dBμV)	Antenna Factor (dB/m)	Path Loss (dB)	Preamp Factor (dB)	Ant Pos (cm)	Table Pos (deg)	Peak Avg. (P/A)	Pol. (H/V)
802.11ax HE20 Full CH 36 5180MHz		10360	47.75	-20.45	68.2	54.34	39.9	14.41	60.9	100	0	P	H
		15540	47.36	-26.64	74	54.79	38	17.28	62.71	100	0	P	H
													H
													H
		10360	47.8	-20.4	68.2	54.39	39.9	14.41	60.9	100	0	P	V
		15540	46.76	-27.24	74	54.19	38	17.28	62.71	100	0	P	V
													V
802.11ax HE20 Full CH 44 5220MHz		10440	48.05	-20.15	68.2	54.56	40.1	14.41	61.02	100	0	P	H
		15660	46.52	-27.48	74	53.73	37.58	17.34	62.13	100	0	P	H
													H
													H
		10440	47.92	-20.28	68.2	54.43	40.1	14.41	61.02	100	0	P	V
		15660	46.43	-27.57	74	53.64	37.58	17.34	62.13	100	0	P	V
													V
802.11ax HE20 Full CH 48 5240MHz		10480	47.62	-20.58	68.2	54.18	40.1	14.41	61.07	100	0	P	H
		15720	45.2	-28.8	74	52.21	37.46	17.37	61.84	100	0	P	H
													H
													H
		10480	47.91	-20.29	68.2	54.47	40.1	14.41	61.07	100	0	P	V
		15720	46.18	-27.82	74	53.19	37.46	17.37	61.84	100	0	P	V
													V
Remark	1. No other spurious found.												
	2. All results are PASS against Peak and Average limit line.												



Band 1 5150~5250MHz
WIFI 802.11ax HE20 Partial 26 (Band Edge @ 3m)

WIFI Ant. 0+1	Note	Frequency (MHz)	Level (dBμV/m)	Over Limit (dB)	Limit Line (dBμV/m)	Read Level (dBμV)	Antenna Factor (dB/m)	Path Loss (dB)	Preamp Factor (dB)	Ant Pos (cm)	Table Pos (deg)	Peak Avg. (P/A)	Pol. (H/V)	
802.11ax HE20 Partial 26/0 CH 36 5180MHz		5047.58	52.97	-21.03	74	40.76	31.89	10.34	30.02	100	311	P	H	
		5123.76	41.97	-12.03	54	29.47	32.05	10.46	30.01	100	311	A	H	
	*	5180	111.04	-	-	98.59	31.92	10.54	30.01	100	311	P	H	
	*	5180	101.38	-	-	88.93	31.92	10.54	30.01	100	311	A	H	
													H	
													H	
			5103.22	53.21	-20.79	74	40.78	32.01	10.43	30.01	107	250	P	V
			5124.28	41.92	-12.08	54	29.42	32.05	10.46	30.01	107	250	A	V
	*		5180	109.78	-	-	97.33	31.92	10.54	30.01	107	250	P	V
	*		5180	100.07	-	-	87.62	31.92	10.54	30.01	107	250	A	V
														V
														V
	802.11ax HE20 Partial 26/4 CH 44 5220MHz		5054.86	52.98	-21.02	74	40.74	31.91	10.35	30.02	100	311	P	H
			5099.58	41.93	-12.07	54	29.52	32	10.42	30.01	100	311	A	H
*		5220	112.05	-	-	99.8	31.68	10.58	30.01	100	311	P	H	
*		5220	101.1	-	-	88.85	31.68	10.58	30.01	100	311	A	H	
			5365.92	53.08	-20.92	74	40.93	31.5	10.65	30	100	311	P	H
			5423.6	41.8	-12.2	54	29.4	31.7	10.69	29.99	100	311	A	H
			5107.38	52.78	-21.22	74	40.35	32.01	10.43	30.01	100	250	P	V
			5107.38	41.88	-12.12	54	29.45	32.01	10.43	30.01	100	250	A	V
*			5220	110.01	-	-	97.76	31.68	10.58	30.01	100	250	P	V
*			5220	100.46	-	-	88.21	31.68	10.58	30.01	100	250	A	V
			5398.68	52.3	-21.7	74	39.95	31.69	10.66	30	100	250	P	V
			5459.16	41.75	-12.25	54	29.26	31.75	10.73	29.99	100	250	A	V



WiFi Ant. 0+1	Note	Frequency (MHz)	Level (dBμV/m)	Over Limit (dB)	Limit Line (dBμV/m)	Read Level (dBμV)	Antenna Factor (dB/m)	Path Loss (dB)	Preamp Factor (dB)	Ant Pos (cm)	Table Pos (deg)	Peak Avg. (P/A)	Pol. (H/V)
802.11ax HE20 Partial 26/8 CH 48 5240MHz		5101.14	52.74	-21.26	74	40.33	32	10.42	30.01	100	312	P	H
		5098.54	41.92	-12.08	54	29.51	32	10.42	30.01	100	312	A	H
	*	5240	112.72	-	-	100.58	31.56	10.59	30.01	100	312	P	H
	*	5240	101.99	-	-	89.85	31.56	10.59	30.01	100	312	A	H
		5400.64	52.56	-21.44	74	40.2	31.7	10.66	30	100	312	P	H
		5416.88	41.78	-12.22	54	29.39	31.7	10.68	29.99	100	312	A	H
		5108.16	52.88	-21.12	74	40.44	32.02	10.43	30.01	108	250	P	V
		5107.38	41.91	-12.09	54	29.48	32.01	10.43	30.01	108	250	A	V
	*	5240	111.1	-	-	98.96	31.56	10.59	30.01	108	250	P	V
	*	5240	100.43	-	-	88.29	31.56	10.59	30.01	108	250	A	V
		5410.44	52.77	-21.23	74	40.4	31.7	10.67	30	108	250	P	V
		5458.88	41.76	-12.24	54	29.27	31.75	10.73	29.99	108	250	A	V
Remark	<ol style="list-style-type: none"> No other spurious found. All results are PASS against Peak and Average limit line. 												



Band 1 5150~5250MHz
WIFI 802.11ax HE20 Partial 52 (Band Edge @ 3m)

WIFI Ant. 0+1	Note	Frequency (MHz)	Level (dBμV/m)	Over Limit (dB)	Limit Line (dBμV/m)	Read Level (dBμV)	Antenna Factor (dB/m)	Path Loss (dB)	Preamp Factor (dB)	Ant Pos (cm)	Table Pos (deg)	Peak Avg. (P/A)	Pol. (H/V)	
802.11ax HE20 Partial 52/37 CH 36 5180MHz		5128.96	52.73	-21.27	74	40.22	32.06	10.46	30.01	100	309	P	H	
		5125.06	42.12	-11.88	54	29.62	32.05	10.46	30.01	100	309	A	H	
	*	5180	112.29	-	-	99.84	31.92	10.54	30.01	100	309	P	H	
	*	5180	101.66	-	-	89.21	31.92	10.54	30.01	100	309	A	H	
													H	
														H
			5128.96	53.55	-20.45	74	41.04	32.06	10.46	30.01	100	250	P	V
			5125.32	42	-12	54	29.5	32.05	10.46	30.01	100	250	A	V
	*		5180	111.09	-	-	98.64	31.92	10.54	30.01	100	250	P	V
	*		5180	100.5	-	-	88.05	31.92	10.54	30.01	100	250	A	V
														V
														V
802.11ax HE20 Partial 52/40 CH 48 5240MHz		5100.36	52.88	-21.12	74	40.47	32	10.42	30.01	100	312	P	H	
		5101.4	42.03	-11.97	54	29.62	32	10.42	30.01	100	312	A	H	
	*	5240	112.14	-	-	100	31.56	10.59	30.01	100	312	P	H	
	*	5240	102.14	-	-	90	31.56	10.59	30.01	100	312	A	H	
			5421.08	52.54	-21.46	74	40.14	31.7	10.69	29.99	100	312	P	H
			5422.76	41.86	-12.14	54	29.46	31.7	10.69	29.99	100	312	A	H
			5140.4	53.67	-20.33	74	41.12	32.08	10.48	30.01	106	250	P	V
			5106.08	41.95	-12.05	54	29.52	32.01	10.43	30.01	106	250	A	V
	*		5240	110.9	-	-	98.76	31.56	10.59	30.01	106	250	P	V
	*		5240	100.77	-	-	88.63	31.56	10.59	30.01	106	250	A	V
			5438.44	52.19	-21.81	74	39.77	31.7	10.71	29.99	106	250	P	V
			5425.28	41.79	-12.21	54	29.39	31.7	10.69	29.99	106	250	A	V
Remark	1. No other spurious found. 2. All results are PASS against Peak and Average limit line.													



Band 1 5150~5250MHz
WIFI 802.11ax HE20 Partial 106 (Band Edge @ 3m)

WIFI Ant. 0+1	Note	Frequency (MHz)	Level (dBμV/m)	Over Limit (dB)	Limit Line (dBμV/m)	Read Level (dBμV)	Antenna Factor (dB/m)	Path Loss (dB)	Preamp Factor (dB)	Ant Pos (cm)	Table Pos (deg)	Peak Avg. (P/A)	Pol. (H/V)	
802.11ax HE20 Partial 106/53 CH 36 5180MHz		5042.38	53.13	-20.87	74	40.94	31.87	10.34	30.02	100	308	P	H	
		5124.54	42.11	-11.89	54	29.61	32.05	10.46	30.01	100	308	A	H	
	*	5180	112.98	-	-	100.53	31.92	10.54	30.01	100	308	P	H	
	*	5180	101.71	-	-	89.26	31.92	10.54	30.01	100	308	A	H	
													H	
														H
			5147.94	53.39	-20.61	74	40.81	32.1	10.49	30.01	100	249	P	V
			5125.32	42.02	-11.98	54	29.52	32.05	10.46	30.01	100	249	A	V
	*		5180	111.73	-	-	99.28	31.92	10.54	30.01	100	249	P	V
	*		5180	100.93	-	-	88.48	31.92	10.54	30.01	100	249	A	V
													V	
													V	
802.11ax HE20 Partial 106/54 CH 48 5240MHz		5094.38	52.73	-21.27	74	40.34	31.99	10.41	30.01	104	309	P	H	
		5102.18	41.85	-12.15	54	29.44	32	10.42	30.01	104	309	A	H	
	*	5240	111.4	-	-	99.26	31.56	10.59	30.01	104	309	P	H	
	*	5240	100.93	-	-	88.79	31.56	10.59	30.01	104	309	A	H	
			5431.72	51.12	-22.88	74	38.71	31.7	10.7	29.99	104	309	P	H
			5427.52	41.57	-12.43	54	29.17	31.7	10.69	29.99	104	309	A	H
			5050.44	52.21	-21.79	74	39.98	31.9	10.35	30.02	111	248	P	V
			5104	41.76	-12.24	54	29.33	32.01	10.43	30.01	111	248	A	V
	*		5240	110.6	-	-	98.46	31.56	10.59	30.01	111	248	P	V
	*		5240	99.59	-	-	87.45	31.56	10.59	30.01	111	248	A	V
		5413.8	51.78	-22.22	74	39.4	31.7	10.68	30	111	248	P	V	
		5460	41.41	-12.59	54	28.91	31.76	10.73	29.99	111	248	A	V	
Remark	1. No other spurious found. 2. All results are PASS against Peak and Average limit line.													



Band 1 5150~5250MHz
WIFI 802.11ax HE40 Full (Band Edge @ 3m)

WIFI Ant. 0+1	Note	Frequency (MHz)	Level (dBμV/m)	Over Limit (dB)	Limit Line (dBμV/m)	Read Level (dBμV)	Antenna Factor (dB/m)	Path Loss (dB)	Preamp Factor (dB)	Ant Pos (cm)	Table Pos (deg)	Peak Avg. (P/A)	Pol. (H/V)
802.11ax HE40 Full CH 38 5190MHz		5140.14	55.99	-18.01	74	43.44	32.08	10.48	30.01	100	298	P	H
		5149.5	47.4	-6.6	54	34.82	32.1	10.49	30.01	100	298	A	H
	*	5190	107.85	-	-	95.45	31.86	10.55	30.01	100	298	P	H
	*	5190	96.82	-	-	84.42	31.86	10.55	30.01	100	298	A	H
		5428.08	51.99	-22.01	74	39.59	31.7	10.69	29.99	100	298	P	H
		5399.24	41.88	-12.12	54	29.52	31.7	10.66	30	100	298	A	H
		5146.9	55.04	-18.96	74	42.47	32.09	10.49	30.01	363	136	P	V
		5150	46.23	-7.77	54	33.65	32.1	10.49	30.01	363	136	A	V
	*	5190	106.68	-	-	94.28	31.86	10.55	30.01	363	136	P	V
	*	5190	95.5	-	-	83.1	31.86	10.55	30.01	363	136	A	V
		5368.44	52.34	-21.66	74	40.18	31.51	10.65	30	363	136	P	V
		5458.6	41.78	-12.22	54	29.29	31.75	10.73	29.99	363	136	A	V
	802.11ax HE40 Full CH 46 5230MHz		5077.22	52.09	-21.91	74	39.77	31.95	10.39	30.02	110	312	P
		5104.78	42.16	-11.84	54	29.73	32.01	10.43	30.01	110	312	A	H
*		5230	109.4	-	-	97.21	31.62	10.58	30.01	110	312	P	H
*		5230	98.58	-	-	86.39	31.62	10.58	30.01	110	312	A	H
		5397.84	52.28	-21.72	74	39.93	31.69	10.66	30	110	312	P	H
		5406.8	41.9	-12.1	54	29.53	31.7	10.67	30	110	312	A	H
		5135.72	52.49	-21.51	74	39.96	32.07	10.47	30.01	346	132	P	V
		5097.24	41.95	-12.05	54	29.55	31.99	10.42	30.01	346	132	A	V
*		5230	108.56	-	-	96.37	31.62	10.58	30.01	346	132	P	V
*		5230	97.63	-	-	85.44	31.62	10.58	30.01	346	132	A	V
	5434.8	51.36	-22.64	74	38.95	31.7	10.7	29.99	346	132	P	V	
	5398.96	41.78	-12.22	54	29.43	31.69	10.66	30	346	132	A	V	
Remark	1. No other spurious found. 2. All results are PASS against Peak and Average limit line.												



Band 1 5150~5250MHz

WIFI 802.11ax HE40 Full (Harmonic @ 3m)

WIFI Ant. 0+1	Note	Frequency (MHz)	Level (dBμV/m)	Over Limit (dB)	Limit Line (dBμV/m)	Read Level (dBμV)	Antenna Factor (dB/m)	Path Loss (dB)	Preamp Factor (dB)	Ant Pos (cm)	Table Pos (deg)	Peak Avg. (P/A)	Pol. (H/V)	
802.11ax HE40 Full CH 38 5190MHz		10380	47.92	-20.28	68.2	54.44	40	14.41	60.93	100	0	P	H	
		15570	46.53	-27.47	74	53.95	37.85	17.29	62.56	100	0	P	H	
													H	
													H	
			10380	47.61	-20.59	68.2	54.13	40	14.41	60.93	100	0	P	V
			15570	47.12	-26.88	74	54.54	37.85	17.29	62.56	100	0	P	V
														V
802.11ax HE40 Full CH 46 5230MHz		10460	47.55	-20.65	68.2	54.08	40.1	14.41	61.04	100	0	P	H	
		15690	46.72	-27.28	74	53.84	37.52	17.35	61.99	100	0	P	H	
													H	
													H	
			10460	47.15	-21.05	68.2	53.68	40.1	14.41	61.04	100	0	P	V
			15690	46.24	-27.76	74	53.36	37.52	17.35	61.99	100	0	P	V
														V
Remark	1. No other spurious found.													
	2. All results are PASS against Peak and Average limit line.													



Band 1 5150~5250MHz
WIFI 802.11ax HE40 Partial 242 (Band Edge @ 3m)

WIFI Ant. 0+1	Note	Frequency (MHz)	Level (dBμV/m)	Over Limit (dB)	Limit Line (dBμV/m)	Read Level (dBμV)	Antenna Factor (dB/m)	Path Loss (dB)	Preamp Factor (dB)	Ant Pos (cm)	Table Pos (deg)	Peak Avg. (P/A)	Pol. (H/V)
802.11ax HE40 Partial 242/61 CH 38 5190MHz		5150	68.56	-5.44	74	55.98	32.1	10.49	30.01	100	310	P	H
		5150	47.8	-6.2	54	35.22	32.1	10.49	30.01	100	310	A	H
	*	5190	108.75	-	-	96.35	31.86	10.55	30.01	100	310	P	H
	*	5190	98.01	-	-	85.61	31.86	10.55	30.01	100	310	A	H
		5429.48	52.24	-21.76	74	39.83	31.7	10.7	29.99	100	310	P	H
		5459.72	41.5	-12.5	54	29	31.76	10.73	29.99	100	310	A	H
		5150	67.96	-6.04	74	55.38	32.1	10.49	30.01	100	250	P	V
		5150	47.66	-6.34	54	35.08	32.1	10.49	30.01	100	250	A	V
	*	5190	108.24	-	-	95.84	31.86	10.55	30.01	100	250	P	V
	*	5190	97.01	-	-	84.61	31.86	10.55	30.01	100	250	A	V
		5456.36	51.66	-22.34	74	39.18	31.74	10.73	29.99	100	250	P	V
		5458.6	41.39	-12.61	54	28.9	31.75	10.73	29.99	100	250	A	V
802.11ax HE40 Partial 242/62 CH 46 5230MHz		5138.32	53.74	-20.26	74	41.19	32.08	10.48	30.01	100	308	P	H
		5101.92	41.86	-12.14	54	29.45	32	10.42	30.01	100	308	A	H
	*	5230	108.44	-	-	96.25	31.62	10.58	30.01	100	308	P	H
	*	5230	97.72	-	-	85.53	31.62	10.58	30.01	100	308	A	H
		5390.28	53	-21	74	40.7	31.64	10.66	30	100	308	P	H
		5414.64	41.55	-12.45	54	29.17	31.7	10.68	30	100	308	A	H
		5111.54	52.81	-21.19	74	40.36	32.02	10.44	30.01	100	249	P	V
		5100.62	41.76	-12.24	54	29.35	32	10.42	30.01	100	249	A	V
	*	5230	106.98	-	-	94.79	31.62	10.58	30.01	100	249	P	V
	*	5230	96.72	-	-	84.53	31.62	10.58	30.01	100	249	A	V
	5386.36	52.57	-21.43	74	40.3	31.62	10.65	30	100	249	P	V	
	5458.88	41.42	-12.58	54	28.93	31.75	10.73	29.99	100	249	A	V	
Remark	1. No other spurious found. 2. All results are PASS against Peak and Average limit line.												



Band 1 5150~5250MHz
WIFI 802.11ax HE80 Full (Band Edge @ 3m)

WIFI Ant. 0+1	Note	Frequency (MHz)	Level (dBμV/m)	Over Limit (dB)	Limit Line (dBμV/m)	Read Level (dBμV)	Antenna Factor (dB/m)	Path Loss (dB)	Preamp Factor (dB)	Ant Pos (cm)	Table Pos (deg)	Peak Avg. (P/A)	Pol. (H/V)
802.11ax HE80 Full CH 42 5210MHz		5148.98	62.83	-11.17	74	50.67	32.1	10.49	30.43	100	303	P	H
		5149.5	48.92	-5.08	54	36.76	32.1	10.49	30.43	100	303	A	H
	*	5210	105.07	-	-	93.19	31.74	10.57	30.43	100	303	P	H
	*	5210	94.26	-	-	82.38	31.74	10.57	30.43	100	303	A	H
		5432.84	52.6	-21.4	74	40.63	31.7	10.7	30.43	100	303	P	H
		5411	41.43	-12.57	54	29.49	31.7	10.67	30.43	100	303	A	H
		5148.72	56.61	-17.39	74	44.45	32.1	10.49	30.43	301	136	P	V
		5147.94	46.29	-7.71	54	34.13	32.1	10.49	30.43	301	136	A	V
	*	5210	102.68	-	-	90.8	31.74	10.57	30.43	301	136	P	V
	*	5210	92.44	-	-	80.56	31.74	10.57	30.43	301	136	A	V
		5386.92	52.36	-21.64	74	40.52	31.62	10.65	30.43	301	136	P	V
		5424.44	41.25	-12.75	54	29.29	31.7	10.69	30.43	301	136	A	V
Remark	1. No other spurious found. 2. All results are PASS against Peak and Average limit line.												



Band 1 5150~5250MHz

WIFI 802.11ax HE80 Full (Harmonic @ 3m)

WIFI Ant. 0+1	Note	Frequency (MHz)	Level (dBμV/m)	Over Limit (dB)	Limit Line (dBμV/m)	Read Level (dBμV)	Antenna Factor (dB/m)	Path Loss (dB)	Preamp Factor (dB)	Ant Pos (cm)	Table Pos (deg)	Peak Avg. (P/A)	Pol. (H/V)
802.11ax HE80 Full		10420	47.32	-20.88	68.2	53.8	40.1	14.41	60.99	100	0	P	H
		15630	46.24	-27.76	74	53.56	37.64	17.32	62.28	100	0	P	H
													H
													H
CH 42 5210MHz		10420	47.11	-21.09	68.2	53.59	40.1	14.41	60.99	100	0	P	V
		15630	45.83	-28.17	74	53.15	37.64	17.32	62.28	100	0	P	V
													V
													V
Remark	1. No other spurious found. 2. All results are PASS against Peak and Average limit line.												



Band 1 5150~5250MHz
WIFI 802.11ax HE80 Partial 242 (Band Edge @ 3m)

WIFI Ant. 0+1	Note	Frequency (MHz)	Level (dBμV/m)	Over Limit (dB)	Limit Line (dBμV/m)	Read Level (dBμV)	Antenna Factor (dB/m)	Path Loss (dB)	Preamp Factor (dB)	Ant Pos (cm)	Table Pos (deg)	Peak Avg. (P/A)	Pol. (H/V)
802.11ax HE80 Partial 484/65 CH 42 5210MHz		5119.08	68.18	-5.82	74	55.7	32.04	10.45	30.01	100	308	P	H
		5119.34	45.55	-8.45	54	33.07	32.04	10.45	30.01	100	308	A	H
	*	5210	105.03	-	-	92.73	31.74	10.57	30.01	100	308	P	H
	*	5210	94.42	-	-	82.12	31.74	10.57	30.01	100	308	A	H
		5404.28	52.32	-21.68	74	39.95	31.7	10.67	30	100	308	P	H
		5425.84	41.5	-12.5	54	29.1	31.7	10.69	29.99	100	308	A	H
		5121.16	67.69	-6.31	74	55.21	32.04	10.45	30.01	100	251	P	V
		5121.42	45.37	-8.63	54	32.89	32.04	10.45	30.01	100	251	A	V
	*	5210	104.57	-	-	92.27	31.74	10.57	30.01	100	251	P	V
	*	5210	93.4	-	-	81.1	31.74	10.57	30.01	100	251	A	V
		5358.64	50.94	-23.06	74	38.85	31.45	10.64	30	100	251	P	V
		5459.16	41.43	-12.57	54	28.94	31.75	10.73	29.99	100	251	A	V
802.11ax HE80 Partial 484/66 CH 42 5210MHz		5119.6	67.96	-6.04	74	55.48	32.04	10.45	30.01	100	300	P	H
		5150	45.65	-8.35	54	33.07	32.1	10.49	30.01	100	300	A	H
	*	5210	104.6	-	-	92.3	31.74	10.57	30.01	100	300	P	H
	*	5210	94.18	-	-	81.88	31.74	10.57	30.01	100	300	A	H
		5427.24	52.76	-21.24	74	40.36	31.7	10.69	29.99	100	300	P	H
		5425.84	41.51	-12.49	54	29.11	31.7	10.69	29.99	100	300	A	H
		5120.12	67.2	-6.8	74	54.72	32.04	10.45	30.01	100	250	P	V
		5150	45.5	-8.5	54	32.92	32.1	10.49	30.01	100	250	A	V
	*	5210	103.92	-	-	91.62	31.74	10.57	30.01	100	250	P	V
	*	5210	93.61	-	-	81.31	31.74	10.57	30.01	100	250	A	V
		5417.16	52.21	-21.79	74	39.82	31.7	10.68	29.99	100	250	P	V
		5423.88	41.4	-12.6	54	29	31.7	10.69	29.99	100	250	A	V
Remark	1. No other spurious found. 2. All results are PASS against Peak and Average limit line.												



Emission below 1GHz
WIFI 802.11ax HE80 Full (LF @ 3m)

WIFI Ant. 0+1	Note	Frequency (MHz)	Level (dBμV/m)	Over Limit (dB)	Limit Line (dBμV/m)	Read Level (dBμV)	Antenna Factor (dB/m)	Path Loss (dB)	Preamp Factor (dB)	Ant Pos (cm)	Table Pos (deg)	Peak Avg. (P/A)	Pol. (H/V)
		79.47	25.9	-14.1	40	43.65	13.57	1.2	32.52	-	-	P	H
		122.15	24.39	-19.11	43.5	37.63	17.68	1.52	32.44	-	-	P	H
		210.42	33	-10.5	43.5	48.45	14.88	2.06	32.39	-	-	P	H
		340.4	25.74	-20.26	46	35.71	19.98	2.51	32.46	-	-	P	H
		824.43	32.9	-13.1	46	32.91	27.83	4.05	31.89	-	-	P	H
		891.36	36	-10	46	35.15	28.51	4.27	31.93	100	0	P	H
													H
													H
													H
													H
													H
													H
802.11ax HE80 Full LF		38.73	25.07	-14.93	40	36.61	20	0.8	32.34	-	-	P	V
		106.63	24.13	-19.37	43.5	38.28	16.77	1.4	32.32	-	-	P	V
		207.51	28.72	-14.78	43.5	44.17	14.88	2.05	32.38	-	-	P	V
		722.58	33.02	-12.98	46	34.74	26.97	3.74	32.43	-	-	P	V
		824.43	36.43	-9.57	46	36.44	27.83	4.05	31.89	100	0	P	V
		889.42	36.06	-9.94	46	35.23	28.49	4.26	31.92	-	-	P	V
													V
													V
													V
													V
													V
													V
													V
Remark	1. No other spurious found. 2. All results are PASS against limit line.												



Note symbol

*	Fundamental Frequency which can be ignored. However, the level of any unwanted emissions shall not exceed the level of the fundamental frequency.
!	Test result is over limit line.
P/A	Peak or Average
H/V	Horizontal or Vertical



A calculation example for radiated spurious emission is shown as below:

WIFI	Note	Frequency	Level	Over	Limit	Read	Antenna	Path	Preamp	Ant	Table	Peak	Pol.
Ant.				Limit	Line	Level	Factor	Loss	Factor	Pos	Pos	Avg.	
0+1		(MHz)	(dBμV/m)	(dB)	(dBμV/m)	(dBμV)	(dB/m)	(dB)	(dB)	(cm)	(deg)	(P/A)	(H/V)
802.11b		2390	55.45	-18.55	74	54.51	32.22	4.58	35.86	103	308	P	H
CH 01													
2412MHz		2390	43.54	-10.46	54	42.6	32.22	4.58	35.86	103	308	A	H

1. Path Loss(dB) = Cable loss(dB) + Filter loss(dB) + Attenuator loss(dB)
2. Level(dBμV/m) = Antenna Factor(dB/m) + Path Loss(dB) + Read Level(dBμV) - Preamp Factor(dB)
3. Over Limit(dB) = Level(dBμV/m) – Limit Line(dBμV/m)

For Peak Limit @ 2390MHz:

1. Level(dBμV/m)
= Antenna Factor(dB/m) + Path Loss(dB) + Read Level(dBμV) - Preamp Factor(dB)
= 32.22(dB/m) + 4.58(dB) + 54.51(dBμV) – 35.86 (dB)
= 55.45 (dBμV/m)
2. Over Limit(dB)
= Level(dBμV/m) – Limit Line(dBμV/m)
= 55.45(dBμV/m) – 74(dBμV/m)
= -18.55(dB)

For Average Limit @ 2390MHz:

1. Level(dBμV/m)
= Antenna Factor(dB/m) + Path Loss(dB) + Read Level(dBμV) - Preamp Factor(dB)
= 32.22(dB/m) + 4.58(dB) + 42.6(dBμV) – 35.86 (dB)
= 43.54 (dBμV/m)
2. Over Limit(dB) = Level(dBμV/m) – Limit Line(dBμV/m)
= 43.54(dBμV/m) – 54(dBμV/m)
= -10.46(dB)

Both peak and average measured complies with the limit line, so test result is “PASS”.



Appendix D. Radiated Spurious Emission

Test Engineer :	Leo Lee, Mancy Chou and Bigshow Wang	Temperature :	22.1~24°C
		Relative Humidity :	45~59%

Note symbol

-L	Low channel location
-R	High channel location



Band 1 - 5150~5250MHz
WIFI 802.11a (Band Edge @ 3m)

WIFI	Band 1 5150~5250MHz Band Edge @ 3m	
ANT	802.11a CH36 5180MHz	
0+1	Horizontal	Fundamental
Peak	<p>Site : 03CH15-HY Condition : PEAK_BE_74 3m 91200_15_1620 HORIZONTAL Detector : Peak Project : 041657</p>	<p>Site : 03CH15-HY Condition : PEAK(LINE) 3m 91200_15_1620 HORIZONTAL Detector : Peak Project : 041657</p>
Avg.	<p>Site : 03CH15-HY Condition : AV6_BE_54 3m 91200_15_1620 HORIZONTAL Detector : Peak Project : 041657</p>	Left blank

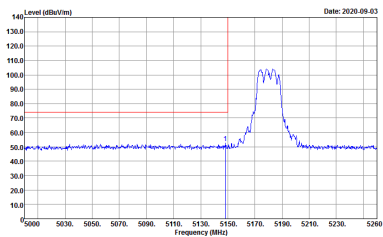
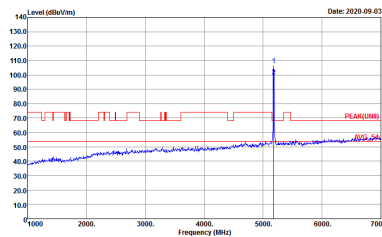
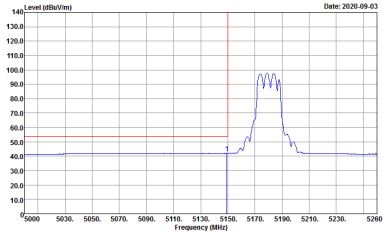

WIFI	Band 1 5150~5250MHz Band Edge @ 3m	
ANT	802.11a CH36 5180MHz	
0+1	Vertical	Fundamental
<p>Peak</p>	 <p>Site : 03CH15-HY Condition : PEAK_BE_74 3m 91200_15_1620 VERTICAL Detector : Peak Project : 041657</p>	 <p>Site : 03CH15-HY Condition : PEAK(LINII) 3m 91200_15_1620 VERTICAL Detector : Peak Project : 041657</p>
<p>Avg.</p>	 <p>Site : 03CH15-HY Condition : AVG_BE_54 3m 91200_15_1620 VERTICAL Detector : Peak Project : 041657</p>	<p>Left blank</p>

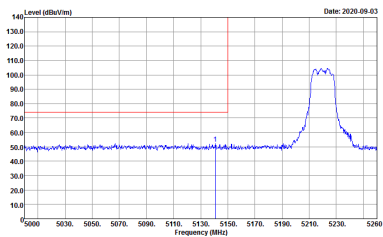
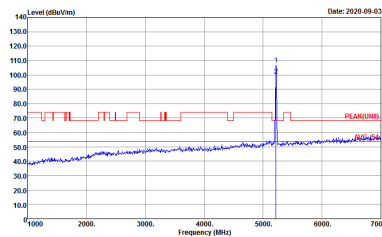
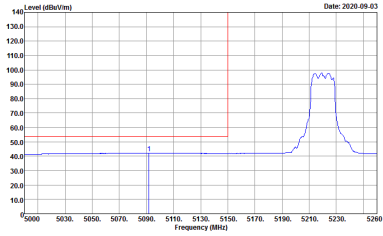

WIFI	Band 1 5150~5250MHz Band Edge @ 3m	
ANT	802.11a CH44 5220MHz - L	
0+1	Horizontal	Fundamental
<p>Peak</p>	 <p>Date: 2020-09-03</p> <p>Site : 03CH15-HY Condition : PEAK_BE_74 3m 91200_15_1620 HORIZONTAL RBW:1000.000KHz VBW:3000.000KHz SWT:Auto Detector : Peak Project : -041657</p>	 <p>Date: 2020-09-03</p> <p>Site : 03CH15-HY Condition : PEAKUNII 3m 91200_15_1620 HORIZONTAL RBW:1000.000KHz VBW:3000.000KHz SWT:Auto Detector : Peak Project : -041657</p>
<p>Avg.</p>	 <p>Date: 2020-09-03</p> <p>Site : 03CH15-HY Condition : AVG_BE_54 3m 91200_15_1620 HORIZONTAL RBW:1000.000KHz VBW:3000.000KHz SWT:Auto Detector : Peak Project : -041657</p>	<p>Left blank</p>

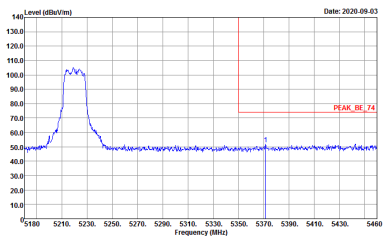
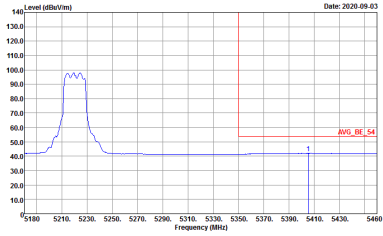

WIFI	Band 1 5150~5250MHz Band Edge @ 3m	
ANT	802.11a CH44 5220MHz - R	
0+1	Horizontal	Fundamental
<p>Peak</p>	 <p>Site : 03CH15-HY Condition : PEAK_BE_74 3m 91200_15_1620 HORIZONTAL Detector : Peak Project : 041657</p>	<p>Left blank</p>
<p>Avg.</p>	 <p>Site : 03CH15-HY Condition : AVG_BE_54 3m 91200_15_1620 HORIZONTAL Detector : Peak Project : 041657</p>	<p>Left blank</p>

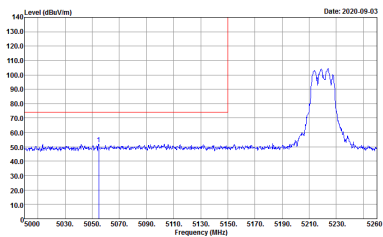
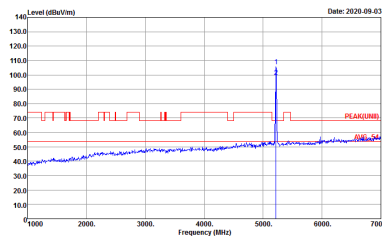
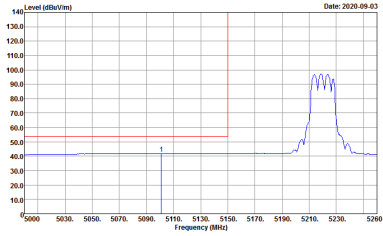

WIFI	Band 1 5150~5250MHz Band Edge @ 3m	
ANT	802.11a CH44 5220MHz - L	
0+1	Vertical	Fundamental
<p>Peak</p>	 <p>Site : 03CH15-HY Condition : PEAK_BE_74 3m 91200_15_1620 VERTICAL Detector : Peak Project : 041657</p>	 <p>Site : 03CH15-HY Condition : PEAK(LINII) 3m 91200_15_1620 VERTICAL Detector : Peak Project : 041657</p>
<p>Avg.</p>	 <p>Site : 03CH15-HY Condition : AVG_BE_54 3m 91200_15_1620 VERTICAL Detector : Peak Project : 041657</p>	<p>Left blank</p>



WIFI	Band 1 5150~5250MHz Band Edge @ 3m	
ANT	802.11a CH44 5220MHz - R	
0+1	Vertical	Fundamental
Peak	<p>Site : 03CH15-HY Condition : PEAK_BE_74 3m 91200_15_1620 VERTICAL Detector : Peak Project : 041657</p>	Left blank
Avg.	<p>Site : 03CH15-HY Condition : AVG_BE_54 3m 91200_15_1620 VERTICAL Detector : Peak Project : 041657</p>	Left blank



WIFI	Band 1 5150~5250MHz Band Edge @ 3m	
ANT	802.11a CH48 5240MHz - L	
0+1	Horizontal	Fundamental
<p>Peak</p>	<p>Date: 2020-09-03</p> <p>Site : 03CH15-HY Condition : PEAK_BE_74 3m 91200_15_1620 HORIZONTAL RBW:1000.000kHz VBW:3000.000kHz SWT:Auto Detector : Peak Project : -041657</p>	<p>Date: 2020-09-03</p> <p>Site : 03CH15-HY Condition : PEAKUNII 3m 91200_15_1620 HORIZONTAL RBW:1000.000kHz VBW:3000.000kHz SWT:Auto Detector : Peak Project : -041657</p>
<p>Avg.</p>	<p>Date: 2020-09-03</p> <p>Site : 03CH15-HY Condition : AVG_BE_54 3m 91200_15_1620 HORIZONTAL RBW:1000.000kHz VBW:0.010kHz SWT:Auto Detector : Peak Project : -041657</p>	<p>Left blank</p>

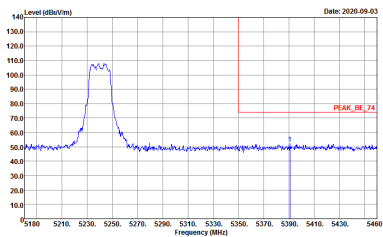
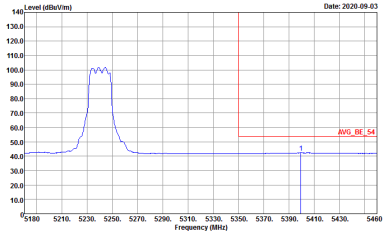

WIFI	Band 1 5150~5250MHz Band Edge @ 3m	
ANT	802.11a CH48 5240MHz - R	
0+1	Horizontal	Fundamental
<p>Peak</p>	 <p>Site : 03CH15-HY Condition : PEAK_BE_74 3m 91200_15_1620 HORIZONTAL Detector : Peak Project : 041657</p>	<p>Left blank</p>
<p>Avg.</p>	 <p>Site : 03CH15-HY Condition : AVG_BE_54 3m 91200_15_1620 HORIZONTAL Detector : Peak Project : 041657</p>	<p>Left blank</p>



WIFI	Band 1 5150~5250MHz Band Edge @ 3m	
ANT	802.11a CH48 5240MHz - L	
0+1	Vertical	Fundamental
Peak	<p>Date: 2020-09-03</p> <p>Site : 03CH15-HY Condition : PEAK_BE_74 3m 91200_15_1620 VERTICAL Detector : Peak Project : 041657</p>	<p>Date: 2020-09-03</p> <p>Site : 03CH15-HY Condition : PEAK(UNII) 3m 91200_15_1620 VERTICAL Detector : Peak Project : 041657</p>
Avg.	<p>Date: 2020-09-03</p> <p>Site : 03CH15-HY Condition : AVG_BE_54 3m 91200_15_1620 VERTICAL Detector : Peak Project : 041657</p>	Left blank

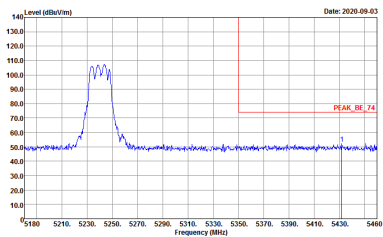
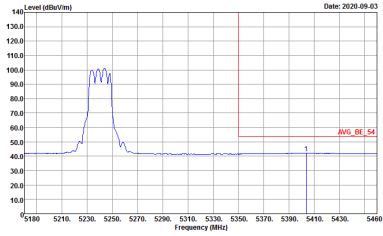

WIFI	Band 1 5150~5250MHz Band Edge @ 3m	
ANT	802.11a CH48 5240MHz - R	
0+1	Vertical	Fundamental
<p>Peak</p>	 <p>Site : 03CH15-HY Condition : PEAK_BE_74 3m 91200_15_1620 VERTICAL Detector : Peak Project : 041657</p>	<p>Left blank</p>
<p>Avg.</p>	 <p>Site : 03CH15-HY Condition : AVG_BE_54 3m 91200_15_1620 VERTICAL Detector : Peak Project : 041657</p>	<p>Left blank</p>

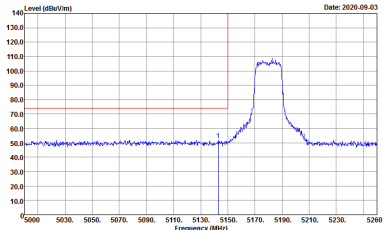
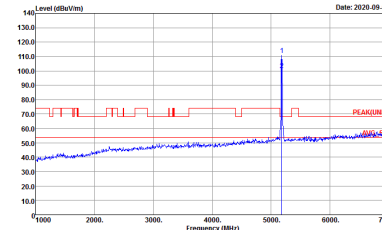
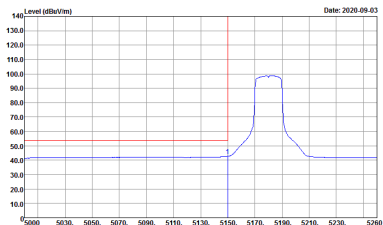

Band 1 5150~5250MHz
WIFI 802.11ax HE20 Full (Band Edge @ 3m)

WIFI	Band 1 5150~5250MHz Band Edge @ 3m	
ANT	802.11ax HE20 Full CH36 5180MHz	
0+1	Horizontal	Fundamental
Peak	 <p>Site : 03CH15-HY Condition : PEAK_BE_74 3m 91200_15_1620 HORIZONTAL RBW:1000.000KHz VBW:3000.000KHz SWT:Auto Detector : Peak Project : 041657</p>	 <p>Site : 03CH15-HY Condition : PEAK(UNIT) 3m 91200_15_1620 HORIZONTAL RBW:1000.000KHz VBW:3000.000KHz SWT:Auto Detector : Peak Project : 041657</p>
Avg.	 <p>Site : 03CH15-HY Condition : AVG_BE_54 3m 91200_15_1620 HORIZONTAL RBW:1000.000KHz VBW:0.010KHz SWT:Auto Detector : Peak Project : 041657</p>	Left blank



WIFI	Band 1 5150~5250MHz Band Edge @ 3m	
ANT	802.11ax HE20 Full CH36 5180MHz	
0+1	Vertical	Fundamental
Peak	<p>Site : 03CH15-HY Condition : PEAK_BE_74 3m 91200_15_1620 VERTICAL Detector : Peak Project : 041657</p>	<p>Site : 03CH15-HY Condition : PEAK(UNII) 3m 91200_15_1620 VERTICAL Detector : Peak Project : 041657</p>
Avg.	<p>Site : 03CH15-HY Condition : AVG_BE_54 3m 91200_15_1620 VERTICAL Detector : Peak Project : 041657</p>	Left blank



WIFI	Band 1 5150~5250MHz Band Edge @ 3m	
ANT	802.11ax HE20 Full CH44 5220MHz - L	
0+1	Horizontal	Fundamental
<p>Peak</p>	<p>Date: 2020-09-03</p> <p>Site : 03CH15-HY Condition : PEAK_BE_74 3m 91200_15_1620 HORIZONTAL : RBW:1000.000KHz VBW:3000.000KHz SWT:Auto Detector : Peak Project : 041657</p>	<p>Date: 2020-09-03</p> <p>Site : 03CH15-HY Condition : PEAK(LINII) 3m 91200_15_1620 HORIZONTAL : RBW:1000.000KHz VBW:3000.000KHz SWT:Auto Detector : Peak Project : 041657</p>
<p>Avg.</p>	<p>Date: 2020-09-03</p> <p>Site : 03CH15-HY Condition : AVG_BE_54 3m 91200_15_1620 HORIZONTAL : RBW:1000.000KHz VBW:3000.000KHz SWT:Auto Detector : Peak Project : 041657</p>	<p>Left blank</p>

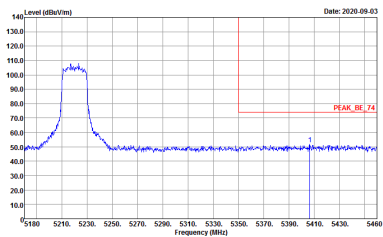
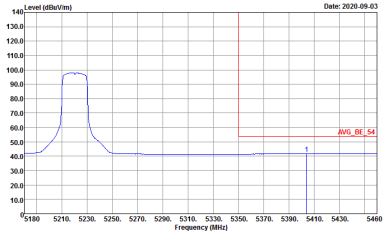

WIFI	Band 1 5150~5250MHz Band Edge @ 3m	
ANT	802.11ax HE20 Full CH44 5220MHz - R	
0+1	Horizontal	Fundamental
Peak	 <p>Site : 03CH15-HY Condition : PEAK_BE_74 3m 9120D_15_1620 HORIZONTAL Detector : Peak Project : 041657</p>	Left blank
Avg.	 <p>Site : 03CH15-HY Condition : AVG_BE_54 3m 9120D_15_1620 HORIZONTAL Detector : Peak Project : 041657</p>	Left blank

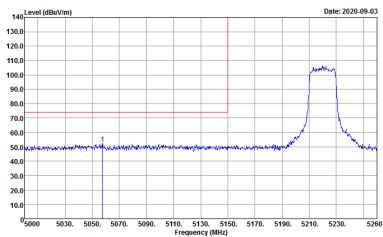
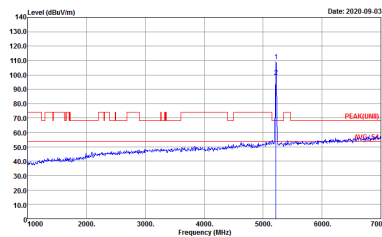
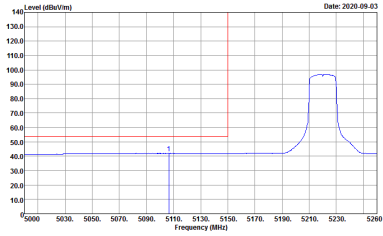

WIFI	Band 1 5150~5250MHz Band Edge @ 3m	
ANT	802.11ax HE20 Full CH44 5220MHz - L	
0+1	Vertical	Fundamental
<p>Peak</p>	 <p>Site : 03CH15-HY Condition : PEAK_BE_74 3m 91200_15_1620 VERTICAL Detector : Peak Project : 041657</p>	 <p>Site : 03CH15-HY Condition : PEAK(LINII) 3m 91200_15_1620 VERTICAL Detector : Peak Project : 041657</p>
<p>Avg.</p>	 <p>Site : 03CH15-HY Condition : AVG_BE_54 3m 91200_15_1620 VERTICAL Detector : Peak Project : 041657</p>	<p>Left blank</p>

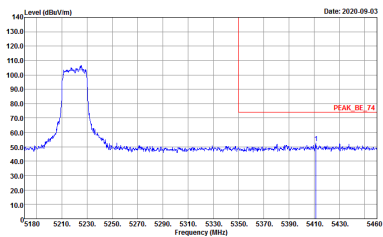
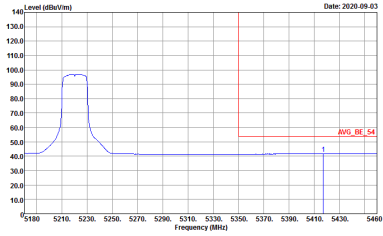

WIFI	Band 1 5150~5250MHz Band Edge @ 3m	
ANT	802.11ax HE20 Full CH44 5220MHz - R	
0+1	Vertical	Fundamental
<p>Peak</p>	 <p>Site : 03CH15-HY Condition : PEAK_BE_74 3m 9120D_15_1620 VERTICAL Detector : Peak Project : 041657</p>	<p>Left blank</p>
<p>Avg.</p>	 <p>Site : 03CH15-HY Condition : AVG_BE_54 3m 9120D_15_1620 VERTICAL Detector : Peak Project : 041657</p>	<p>Left blank</p>

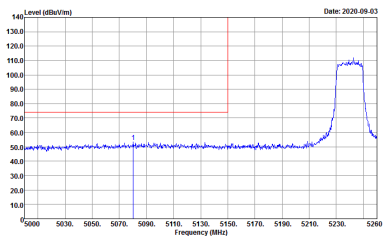
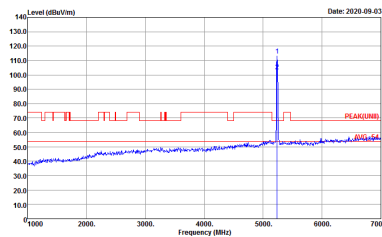
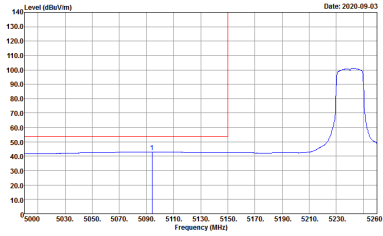

WIFI	Band 1 5150~5250MHz Band Edge @ 3m	
ANT	802.11ax HE20 Full CH48 5240MHz - L	
0+1	Horizontal	Fundamental
Peak	 <p>Site : 03CH15-HY Condition : PEAK_BE_74 3m 91200_15_1620 HORIZONTAL Detector : Peak Project : 041657</p>	 <p>Site : 03CH15-HY Condition : PEAKUNII 3m 91200_15_1620 HORIZONTAL Detector : Peak Project : 041657</p>
Avg.	 <p>Site : 03CH15-HY Condition : AVG_BE_54 3m 91200_15_1620 HORIZONTAL Detector : Peak Project : 041657</p>	Left blank

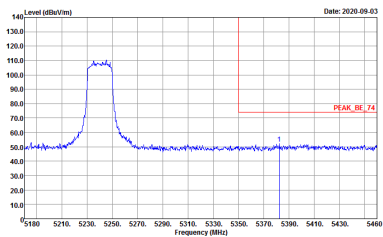
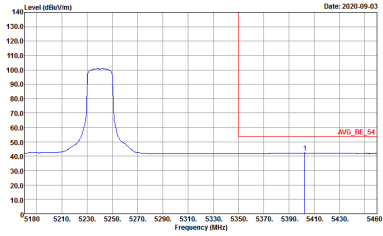

WIFI	Band 1 5150~5250MHz Band Edge @ 3m	
ANT	802.11ax HE20 Full CH48 5240MHz - R	
0+1	Horizontal	Fundamental
<p>Peak</p>	 <p>Site : 03CH15-HY Condition : PEAK_BE_74 3m 91200_15_1620 HORIZONTAL Detector : Peak Project : 041657</p>	<p>Left blank</p>
<p>Avg.</p>	 <p>Site : 03CH15-HY Condition : AVG_BE_54 3m 91200_15_1620 HORIZONTAL Detector : Peak Project : 041657</p>	<p>Left blank</p>

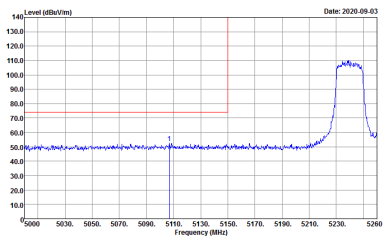
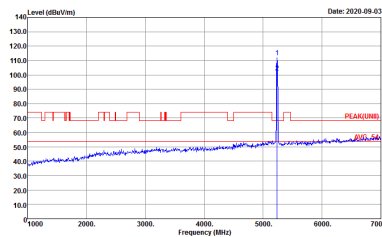
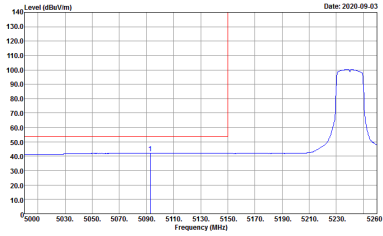

WIFI	Band 1 5150~5250MHz Band Edge @ 3m	
ANT	802.11ax HE20 Full CH48 5240MHz - L	
0+1	Vertical	Fundamental
Peak	 <p>Site : 03CH15-HY Condition : PEAK_BE_74 3m 91200_15_1620 VERTICAL Detector : Peak Project : 041657</p>	 <p>Site : 03CH15-HY Condition : PEAK(LINII) 3m 91200_15_1620 VERTICAL Detector : Peak Project : 041657</p>
Avg.	 <p>Site : 03CH15-HY Condition : AVG_BE_54 3m 91200_15_1620 VERTICAL Detector : Peak Project : 041657</p>	Left blank

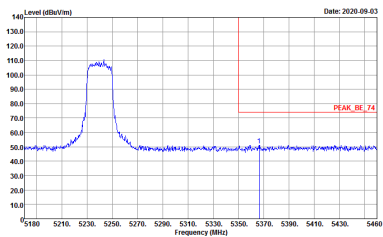
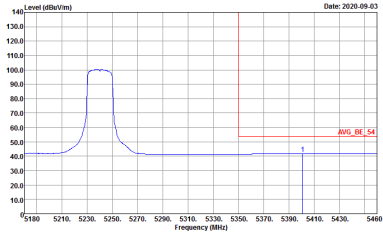

WIFI	Band 1 5150~5250MHz Band Edge @ 3m	
ANT	802.11ax HE20 Full CH48 5240MHz - R	
0+1	Vertical	Fundamental
<p>Peak</p>	 <p>Site : 03CH15-HY Condition : PEAK_BE_74 3m 91200_15_1620 VERTICAL RBW:1000.000KHz VBW:3000.000KHz SWT:Auto Detector : Peak Project : 041657</p>	<p>Left blank</p>
<p>Avg.</p>	 <p>Site : 03CH15-HY Condition : AVG_BE_54 3m 91200_15_1620 VERTICAL RBW:1000.000KHz VBW:3000.000KHz SWT:Auto Detector : Peak Project : 041657</p>	<p>Left blank</p>



Band 1 5150~5250MHz
WIFI 802.11ax HE20 Partial 26 (Band Edge @ 3m)

WIFI	Band 1 5150~5250MHz Band Edge @ 3m	
ANT	802.11ax HE20 Partial 26/0 CH36 5180MHz	
0+1	Horizontal	Fundamental
<p>Peak</p>	<p>Site : 03CH15-HY Condition : PEAK_BE_74 3m 91200_15_1620 HORIZONTAL RBW:1000.000KHz VBW:3000.000KHz SWT:Auto Detector : Peak Project : 041657</p>	<p>Site : 03CH15-HY Condition : PEAK(UNIT) 3m 91200_15_1620 HORIZONTAL RBW:1000.000KHz VBW:3000.000KHz SWT:Auto Detector : Peak Project : 041657</p>
<p>Avg.</p>	<p>Site : 03CH15-HY Condition : AVG_BE_54 3m 91200_15_1620 HORIZONTAL RBW:1000.000KHz VBW:0.010KHz SWT:Auto Detector : Peak Project : 041657</p>	<p align="center">Left blank</p>

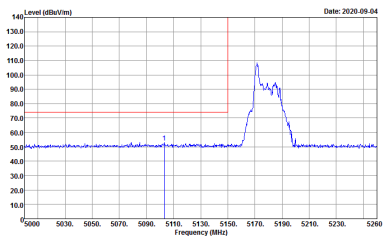
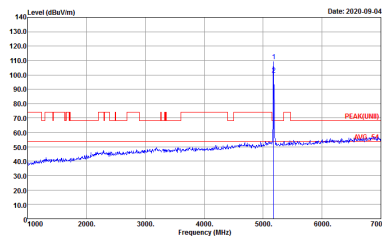
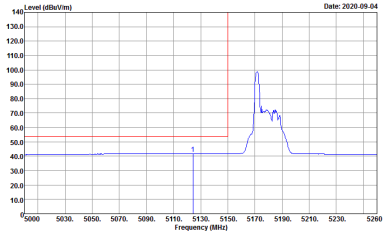

WIFI	Band 1 5150~5250MHz Band Edge @ 3m	
ANT	802.11ax HE20 Partial 26/0 CH36 5180MHz	
0+1	Vertical	Fundamental
Peak	 <p>Date: 2020-09-04</p> <p>Site : 03CH15-HY Condition : PEAK_BE_74 3m 9120D_15_1620 VERTICAL : RBW:1000.000KHz VBW:3000.000KHz SWT:Auto Detector : Peak Project : -041657</p>	 <p>Date: 2020-09-04</p> <p>Site : 03CH15-HY Condition : PEAK(UNII) 3m 9120D_15_1620 VERTICAL : RBW:1000.000KHz VBW:3000.000KHz SWT:Auto Detector : Peak Project : -041657</p>
Avg.	 <p>Date: 2020-09-04</p> <p>Site : 03CH15-HY Condition : AVG_BE_54 3m 9120D_15_1620 VERTICAL : RBW:1000.000KHz VBW:3000.000KHz SWT:Auto Detector : Peak Project : -041657</p>	Left blank

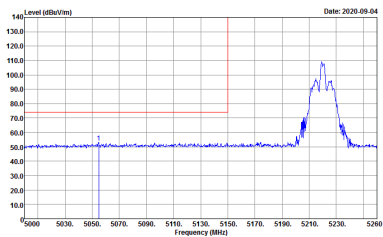
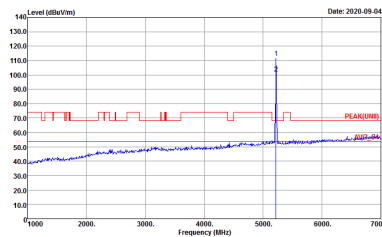
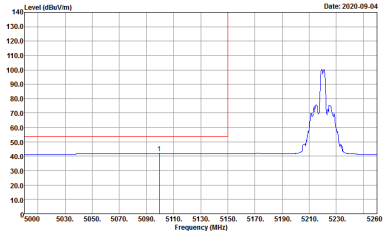

WIFI	Band 1 5150~5250MHz Band Edge @ 3m	
ANT	802.11ax HE20 Partial 26/4 CH44 5220MHz - L	
0+1	Horizontal	Fundamental
<p>Peak</p>	 <p>Date: 2020-09-04</p> <p>Site : 03CH15-HY Condition : PEAK_BE_74 3m 91200_15_1620 HORIZONTAL : RBW:1000.000KHz VBW:3000.000KHz SWT:Auto Detector : Peak Project : 041657</p>	 <p>Date: 2020-09-04</p> <p>Site : 03CH15-HY Condition : PEAKUNII 3m 91200_15_1620 HORIZONTAL : RBW:1000.000KHz VBW:3000.000KHz SWT:Auto Detector : Peak Project : 041657</p>
<p>Avg.</p>	 <p>Date: 2020-09-04</p> <p>Site : 03CH15-HY Condition : AVG_BE_54 3m 91200_15_1620 HORIZONTAL : RBW:1000.000KHz VBW:3000.000KHz SWT:Auto Detector : Peak Project : 041657</p>	<p>Left blank</p>

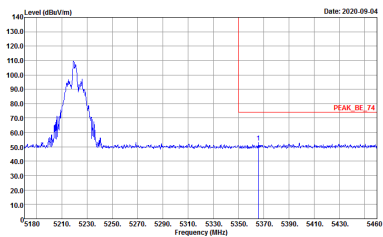
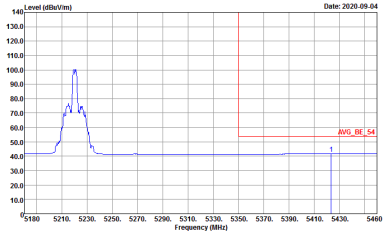

WIFI	Band 1 5150~5250MHz Band Edge @ 3m	
ANT	802.11ax HE20 Partial 26/4 CH44 5220MHz - R	
0+1	Horizontal	Fundamental
<p>Peak</p>	 <p>Site : 03CH15-HY Condition : PEAK_BE_74 3m 9120D_15_1620 HORIZONTAL Detector : Peak Project : 041657</p>	<p>Left blank</p>
<p>Avg.</p>	 <p>Site : 03CH15-HY Condition : AVG_BE_54 3m 9120D_15_1620 HORIZONTAL Detector : Peak Project : 041657</p>	<p>Left blank</p>

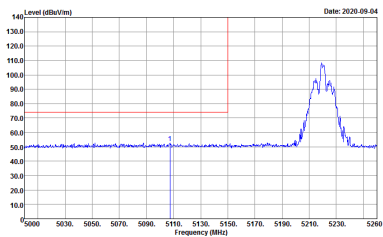
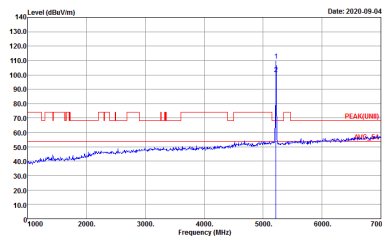
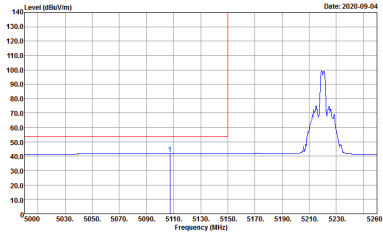

WIFI	Band 1 5150~5250MHz Band Edge @ 3m	
ANT	802.11ax HE20 Partial 26/4 CH44 5220MHz - L	
0+1	Vertical	Fundamental
<p>Peak</p>	 <p>Site : 03CH15-HY Condition : PEAK_BE_74 3m 91200_15_1620 VERTICAL Detector : Peak Project : 041657</p>	 <p>Site : 03CH15-HY Condition : PEAK(UNII) 3m 91200_15_1620 VERTICAL Detector : Peak Project : 041657</p>
<p>Avg.</p>	 <p>Site : 03CH15-HY Condition : AVG_BE_54 3m 91200_15_1620 VERTICAL Detector : Peak Project : 041657</p>	<p>Left blank</p>

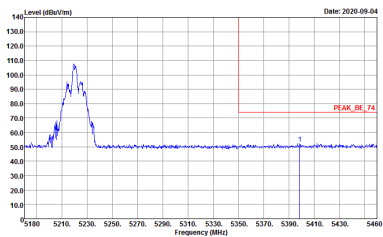
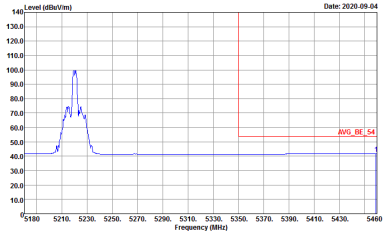

WIFI	Band 1 5150~5250MHz Band Edge @ 3m	
ANT	802.11ax HE20 Partial 26/4 CH44 5220MHz - R	
0+1	Vertical	Fundamental
<p>Peak</p>	 <p>Site : 03CH15-HY Condition : PEAK_BE_74 3m 91200_15_1620 VERTICAL Detector : Peak Project : 041657</p>	<p>Left blank</p>
<p>Avg.</p>	 <p>Site : 03CH15-HY Condition : AVG_BE_54 3m 91200_15_1620 VERTICAL Detector : Peak Project : 041657</p>	<p>Left blank</p>

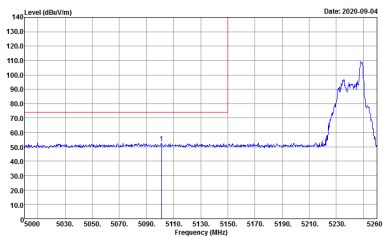
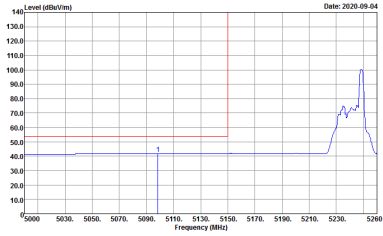

WIFI	Band 1 5150~5250MHz Band Edge @ 3m	
ANT	802.11ax HE20 Partial 26/8 CH48 5240MHz - L	
0+1	Horizontal	Fundamental
<p>Peak</p>	 <p>Date: 2020-09-04</p> <p>Site : 03CH15-HY Condition : PEAK_BE_74 3m 91200_15_1620 HORIZONTAL RBW:1000.000KHz VBW:3000.000KHz SWT:Auto Detector : Peak Project : -041657</p>	 <p>Date: 2020-09-04</p> <p>Site : 03CH15-HY Condition : PEAKUNII 3m 91200_15_1620 HORIZONTAL RBW:1000.000KHz VBW:3000.000KHz SWT:Auto Detector : Peak Project : -041657</p>
<p>Avg.</p>	 <p>Date: 2020-09-04</p> <p>Site : 03CH15-HY Condition : AVG_BE_54 3m 91200_15_1620 HORIZONTAL RBW:1000.000KHz VBW:3000.000KHz SWT:Auto Detector : Peak Project : -041657</p>	<p>Left blank</p>

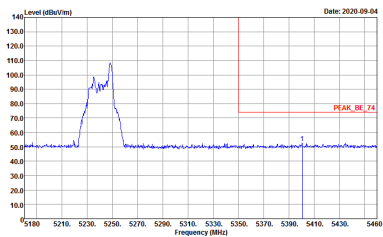
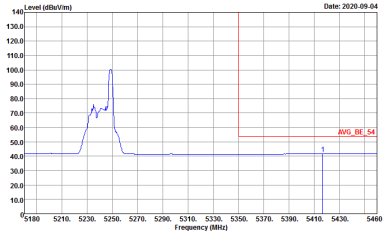

WIFI	Band 1 5150~5250MHz Band Edge @ 3m	
ANT	802.11ax HE20 Partial 26/8 CH48 5240MHz - R	
0+1	Horizontal	Fundamental
<p>Peak</p>	 <p>Site : 03CH15-HY Condition : PEAK_BE_74 3m 91200_15_1620 HORIZONTAL Detector : Peak Project : 041657</p>	<p>Left blank</p>
<p>Avg.</p>	 <p>Site : 03CH15-HY Condition : AVG_BE_54 3m 91200_15_1620 HORIZONTAL Detector : Peak Project : 041657</p>	<p>Left blank</p>

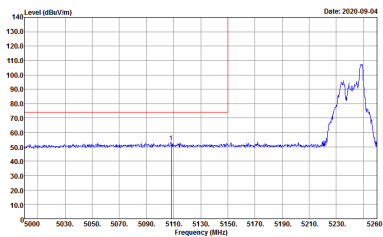
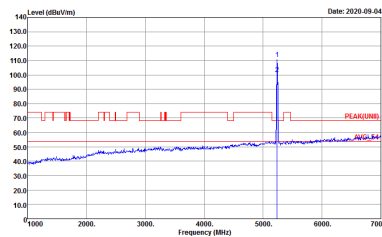
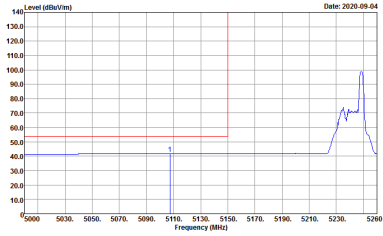

WIFI	Band 1 5150~5250MHz Band Edge @ 3m	
ANT	802.11ax HE20 Partial 26/8 CH48 5240MHz - L	
0+1	Vertical	Fundamental
Peak	 <p>Date: 2020-09-04</p> <p>Site : 03CH15-HY Condition : PEAK_BE_74 3m 91200_15_1620 VERTICAL RBW:1000.000KHz VBW:3000.000KHz SWT:Auto Detector : Peak Project : 041657</p>	 <p>Date: 2020-09-04</p> <p>Site : 03CH15-HY Condition : PEAK(UNII) 3m 91200_15_1620 VERTICAL RBW:1000.000KHz VBW:3000.000KHz SWT:Auto Detector : Peak Project : 041657</p>
Avg.	 <p>Date: 2020-09-04</p> <p>Site : 03CH15-HY Condition : AVG_BE_54 3m 91200_15_1620 VERTICAL RBW:1000.000KHz VBW:3000.000KHz SWT:Auto Detector : Peak Project : 041657</p>	Left blank

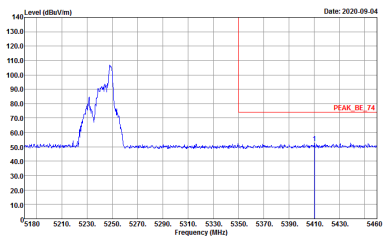
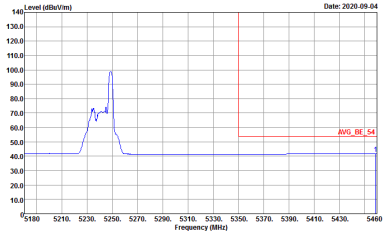

WIFI	Band 1 5150~5250MHz Band Edge @ 3m	
ANT	802.11ax HE20 Partial 26/8 CH48 5240MHz - R	
0+1	Vertical	Fundamental
<p>Peak</p>	 <p>Site : 03CH15-HY Condition : PEAK_BE_74 3m 9120D_15_1620 VERTICAL Detector : Peak Project : 041657</p>	<p>Left blank</p>
<p>Avg.</p>	 <p>Site : 03CH15-HY Condition : AVG_BE_54 3m 9120D_15_1620 VERTICAL Detector : Peak Project : 041657</p>	<p>Left blank</p>

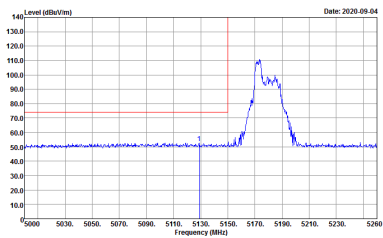
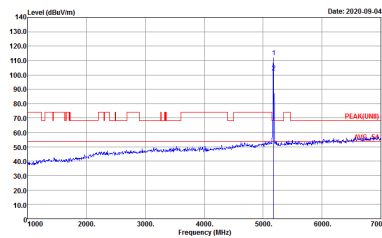
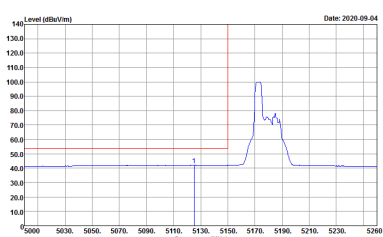

Band 1 5150~5250MHz
WIFI 802.11ax HE20 Partial 52 (Band Edge @ 3m)

WIFI	Band 1 5150~5250MHz Band Edge @ 3m	
ANT	802.11ax HE20 Partial 52/37 CH36 5180MHz	
0+1	Horizontal	Fundamental
Peak	 <p>Site : 03CH15-HY Condition : PEAK_BE_74 3m 91200_15_1620 HORIZONTAL RBW:1000.000KHz VBW:3000.000KHz SWT:Auto Detector : Peak Project : 041657</p>	 <p>Site : 03CH15-HY Condition : PEAK(UNIT) 3m 91200_15_1620 HORIZONTAL RBW:1000.000KHz VBW:3000.000KHz SWT:Auto Detector : Peak Project : 041657</p>
Avg.	 <p>Site : 03CH15-HY Condition : AVG_BE_54 3m 91200_15_1620 HORIZONTAL RBW:1000.000KHz VBW:0.010KHz SWT:Auto Detector : Peak Project : 041657</p>	Left blank

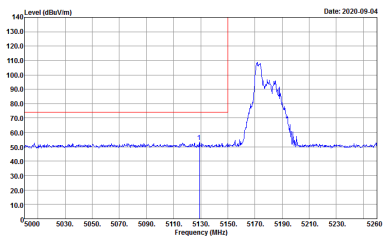
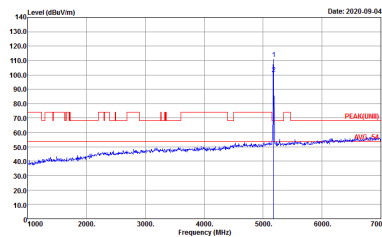
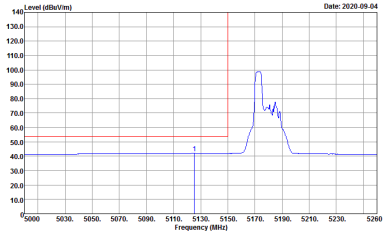

WIFI	Band 1 5150~5250MHz Band Edge @ 3m	
ANT	802.11ax HE20 Partial 52/37 CH36 5180MHz	
0+1	Vertical	Fundamental
<p>Peak</p>	 <p>Date: 2020-09-04</p> <p>Site : 03CH15-HY Condition : PEAK_BE_74 3m 91200_15_1620 VERTICAL : RBW:1000.000KHz VBW:3000.000KHz SWT:Auto Detector : Peak Project : -041657</p>	 <p>Date: 2020-09-04</p> <p>Site : 03CH15-HY Condition : PEAK(UNII) 3m 91200_15_1620 VERTICAL : RBW:1000.000KHz VBW:3000.000KHz SWT:Auto Detector : Peak Project : -041657</p>
<p>Avg.</p>	 <p>Date: 2020-09-04</p> <p>Site : 03CH15-HY Condition : AVG_BE_54 3m 91200_15_1620 VERTICAL : RBW:1000.000KHz VBW:3000.000KHz SWT:Auto Detector : Peak Project : -041657</p>	<p>Left blank</p>

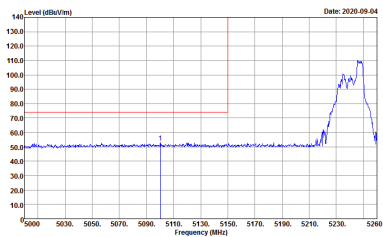
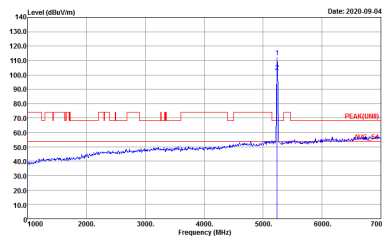
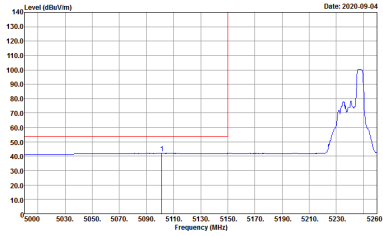

WIFI	Band 1 5150~5250MHz Band Edge @ 3m	
ANT	802.11ax HE20 Partial 52/40 CH48 5240MHz - L	
0+1	Horizontal	Fundamental
<p>Peak</p>	 <p>Site : 03CH15-HY Condition : PEAK_BE_74 3m 91200_15_1620 HORIZONTAL Detector : Peak Project : 041657</p>	 <p>Site : 03CH15-HY Condition : PEAKUNII 3m 91200_15_1620 HORIZONTAL Detector : Peak Project : 041657</p>
<p>Avg.</p>	 <p>Site : 03CH15-HY Condition : AVG_BE_54 3m 91200_15_1620 HORIZONTAL Detector : Peak Project : 041657</p>	<p>Left blank</p>

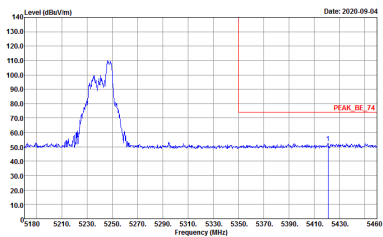
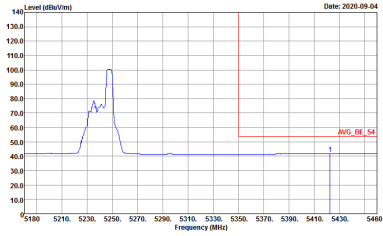

WIFI	Band 1 5150~5250MHz Band Edge @ 3m	
ANT	802.11ax HE20 Partial 52/40 CH48 5240MHz - R	
0+1	Horizontal	Fundamental
<p>Peak</p>	 <p>Site : 03CH15-HY Condition : PEAK_BE_74 3m 91200_15_1620 HORIZONTAL RBW:1000.000KHz VBW:3000.000KHz SWT:Auto Detector : Peak Project : 041657</p>	<p>Left blank</p>
<p>Avg.</p>	 <p>Site : 03CH15-HY Condition : AVG_BE_54 3m 91200_15_1620 HORIZONTAL RBW:1000.000KHz VBW:3000.000KHz SWT:Auto Detector : Peak Project : 041657</p>	<p>Left blank</p>

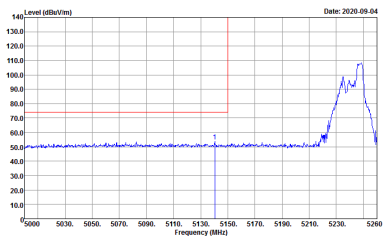
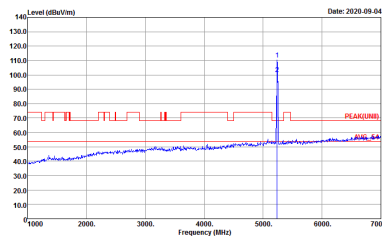
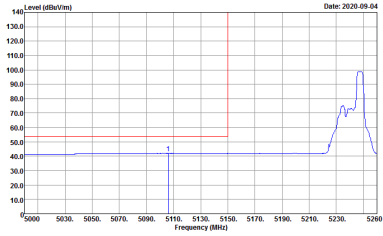

WIFI	Band 1 5150~5250MHz Band Edge @ 3m	
ANT	802.11ax HE20 Partial 52/40 CH48 5240MHz - L	
0+1	Vertical	Fundamental
<p>Peak</p>	 <p>Date: 2020-09-04</p> <p>Site : 03CH15-HY Condition : PEAK_BE_74 3m 91200_15_1620 VERTICAL RBW:1000.000KHz VBW:3000.000KHz SWT:Auto Detector : Peak Project : -041657</p>	 <p>Date: 2020-09-04</p> <p>Site : 03CH15-HY Condition : PEAK(LINII) 3m 91200_15_1620 VERTICAL RBW:1000.000KHz VBW:3000.000KHz SWT:Auto Detector : Peak Project : -041657</p>
<p>Avg.</p>	 <p>Date: 2020-09-04</p> <p>Site : 03CH15-HY Condition : AVG_BE_54 3m 91200_15_1620 VERTICAL RBW:1000.000KHz VBW:3000.000KHz SWT:Auto Detector : Peak Project : -041657</p>	<p>Left blank</p>

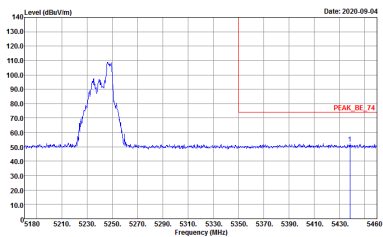
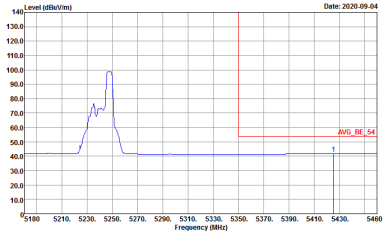

WIFI	Band 1 5150~5250MHz Band Edge @ 3m	
ANT	802.11ax HE20 Partial 52/40 CH48 5240MHz - R	
0+1	Vertical	Fundamental
<p>Peak</p>	 <p>Site : 03CH15-HY Condition : PEAK_BE_74 3m 9120D_15_1620 VERTICAL Detector : Peak Project : 041657</p>	<p>Left blank</p>
<p>Avg.</p>	 <p>Site : 03CH15-HY Condition : AVG_BE_54 3m 9120D_15_1620 VERTICAL Detector : Peak Project : 041657</p>	<p>Left blank</p>



Band 1 5150~5250MHz
WIFI 802.11ax HE20 Partial 106 (Band Edge @ 3m)

WIFI	Band 1 5150~5250MHz Band Edge @ 3m	
ANT	802.11ax HE20 Partial 106/53 CH36 5180MHz	
0+1	Horizontal	Fundamental
Peak	<p>Site : 03CH15-HY Condition : PEAK_BE_74 3m 91200_15_1620 HORIZONTAL RBW:1000.000KHz VBW:3000.000KHz SWT:Auto Detector : Peak Project : 041657</p>	<p>Site : 03CH15-HY Condition : PEAK(UNIT) 3m 91200_15_1620 HORIZONTAL RBW:1000.000KHz VBW:3000.000KHz SWT:Auto Detector : Peak Project : 041657</p>
Avg.	<p>Site : 03CH15-HY Condition : AVG_BE_54 3m 91200_15_1620 HORIZONTAL RBW:1000.000KHz VBW:0.010KHz SWT:Auto Detector : Peak Project : 041657</p>	Left blank

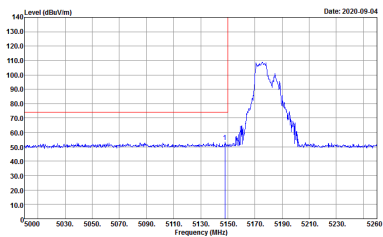
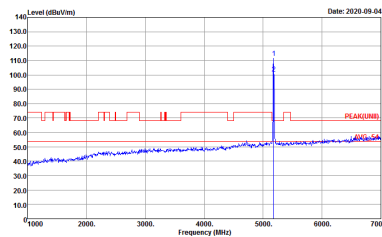
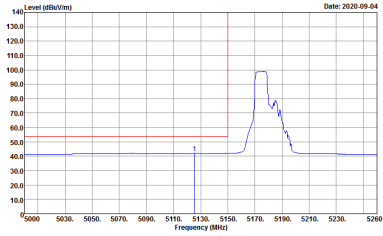

WIFI	Band 1 5150~5250MHz Band Edge @ 3m	
ANT	802.11ax HE20 Partial 106/53 CH36 5180MHz	
0+1	Vertical	Fundamental
<p>Peak</p>	 <p>Site : 03CH15-HY Condition : PEAK_BE_74 3m 91200_15_1620 VERTICAL Detector : Peak Project : 041657</p>	 <p>Site : 03CH15-HY Condition : PEAK(LINII) 3m 91200_15_1620 VERTICAL Detector : Peak Project : 041657</p>
<p>Avg.</p>	 <p>Site : 03CH15-HY Condition : AVG_BE_54 3m 91200_15_1620 VERTICAL Detector : Peak Project : 041657</p>	<p>Left blank</p>

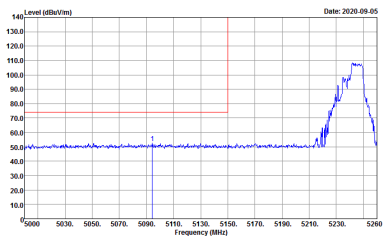
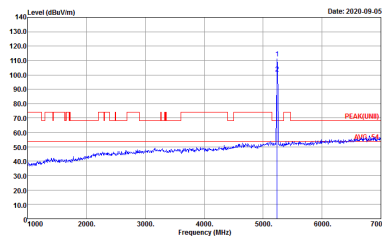
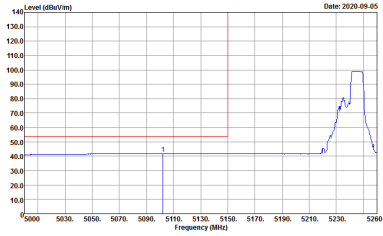

WIFI	Band 1 5150~5250MHz Band Edge @ 3m	
ANT	802.11ax HE20 Partial 106/54 CH48 5240MHz - L	
0+1	Horizontal	Fundamental
<p>Peak</p>	 <p>Date: 2020-09-05</p> <p>Site : 03CH15-HY Condition : PEAK_BE_74 3m 91200_15_1620 HORIZONTAL RBW:1000.000KHz VBW:3000.000KHz SWT:Auto Detector : Peak Project : 041657</p>	 <p>Date: 2020-09-05</p> <p>Site : 03CH15-HY Condition : PEAKUNII 3m 91200_15_1620 HORIZONTAL RBW:1000.000KHz VBW:3000.000KHz SWT:Auto Detector : Peak Project : 041657</p>
<p>Avg.</p>	 <p>Date: 2020-09-05</p> <p>Site : 03CH15-HY Condition : AVG_BE_54 3m 91200_15_1620 HORIZONTAL RBW:1000.000KHz VBW:3000.000KHz SWT:Auto Detector : Peak Project : 041657</p>	<p>Left blank</p>

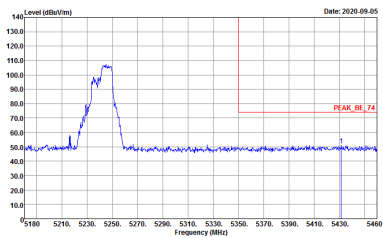
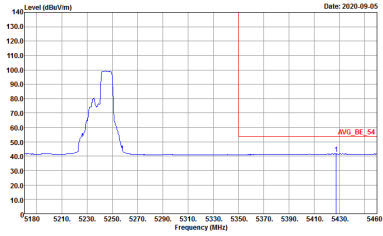

WIFI	Band 1 5150~5250MHz Band Edge @ 3m	
ANT	802.11ax HE20 Partial 106/54 CH48 5240MHz - R	
0+1	Horizontal	Fundamental
<p>Peak</p>	 <p>Site : 03CH15-HY Condition : PEAK_BE_74 3m 91200_15_1620 HORIZONTAL Detector : Peak Project : 041657</p>	<p>Left blank</p>
<p>Avg.</p>	 <p>Site : 03CH15-HY Condition : AVG_BE_54 3m 91200_15_1620 HORIZONTAL Detector : Peak Project : 041657</p>	<p>Left blank</p>

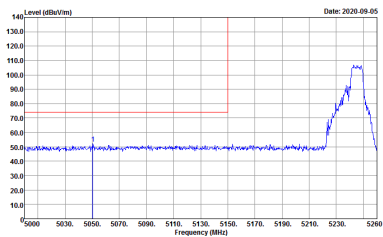
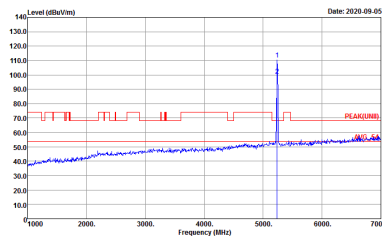
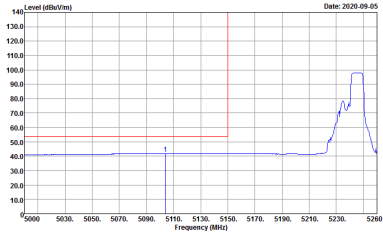

WIFI	Band 1 5150~5250MHz Band Edge @ 3m	
ANT	802.11ax HE20 Partial 106/54 CH48 5240MHz - L	
0+1	Vertical	Fundamental
Peak	 <p>Date: 2020-09-05</p> <p>Site : 03CH15-HY Condition : PEAK_BE_74 3m 91200_15_1620 VERTICAL Detector : Peak Project : 041657</p>	 <p>Date: 2020-09-05</p> <p>Site : 03CH15-HY Condition : PEAK(UNII) 3m 91200_15_1620 VERTICAL Detector : Peak Project : 041657</p>
Avg.	 <p>Date: 2020-09-05</p> <p>Site : 03CH15-HY Condition : AVG_BE_54 3m 91200_15_1620 VERTICAL Detector : Peak Project : 041657</p>	Left blank

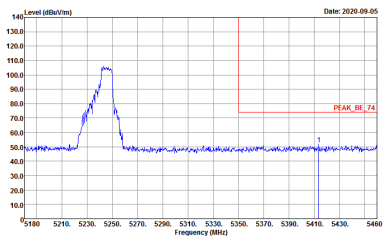
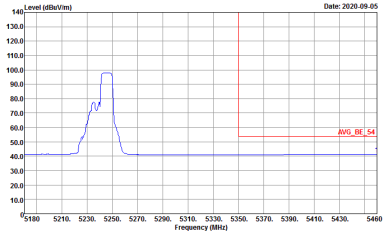

WIFI	Band 1 5150~5250MHz Band Edge @ 3m	
ANT	802.11ax HE20 Partial 106/54 CH48 5240MHz - R	
0+1	Vertical	Fundamental
<p>Peak</p>	 <p>Site : 03CH15-HY Condition : PEAK_BE_74 3m 9120D_15_1620 VERTICAL Detector : Peak Project : 041657</p>	<p>Left blank</p>
<p>Avg.</p>	 <p>Site : 03CH15-HY Condition : AVG_BE_54 3m 9120D_15_1620 VERTICAL Detector : Peak Project : 041657</p>	<p>Left blank</p>

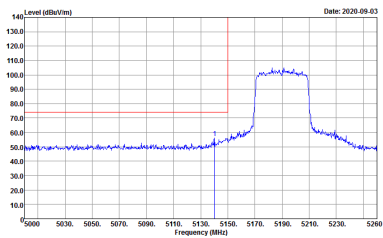
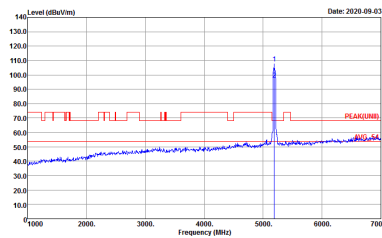
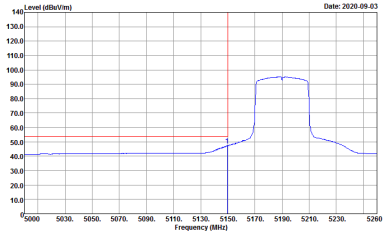

Band 1 5150~5250MHz
WIFI 802.11ax HE40 Full (Band Edge @ 3m)

WIFI	Band 1 5150~5250MHz Band Edge @ 3m	
ANT	802.11ax HE40 Full CH38 5190MHz - L	
0+1	Horizontal	Fundamental
Peak	 <p>Site : 03CH15-HY Condition : PEAK_BE_74 3m 91200_15_1620 HORIZONTAL RBW:1000.000KHz VBW:3000.000KHz SWT:Auto Detector : Peak Project : 041657</p>	 <p>Site : 03CH15-HY Condition : PEAK(UNIT) 3m 91200_15_1620 HORIZONTAL RBW:1000.000KHz VBW:3000.000KHz SWT:Auto Detector : Peak Project : 041657</p>
Avg.	 <p>Site : 03CH15-HY Condition : AVG_BE_54 3m 91200_15_1620 HORIZONTAL RBW:1000.000KHz VBW:0.010KHz SWT:Auto Detector : Peak Project : 041657</p>	Left blank



WIFI	Band 1 5150~5250MHz Band Edge @ 3m	
ANT	802.11ax HE40 Full CH38 5190MHz - R	
0+1	Horizontal	Fundamental
Peak	<p>Site : 03CH15-HY Condition : PEAK_BE_74 3m 9120D_15_1620 HORIZONTAL Detector : Peak Project : 041657</p>	Left blank
Avg.	<p>Site : 03CH15-HY Condition : AVG_BE_54 3m 9120D_15_1620 HORIZONTAL Detector : Peak Project : 041657</p>	Left blank

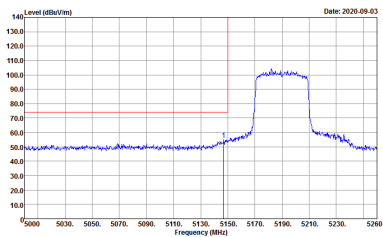
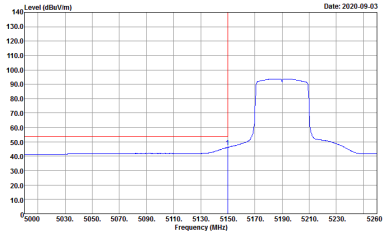

WIFI	Band 1 5150~5250MHz Band Edge @ 3m	
ANT	802.11ax HE40 Full CH38 5190MHz - L	
0+1	Vertical	Fundamental
<p>Peak</p>	 <p>Site : 03CH15-HY Condition : PEAK_BE_74 3m 91200_15_1620 VERTICAL Detector : Peak Project : 041657</p>	 <p>Site : 03CH15-HY Condition : PEAK(LINII) 3m 91200_15_1620 VERTICAL Detector : Peak Project : 041657</p>
<p>Avg.</p>	 <p>Site : 03CH15-HY Condition : AVG_BE_54 3m 91200_15_1620 VERTICAL Detector : Peak Project : 041657</p>	<p>Left blank</p>

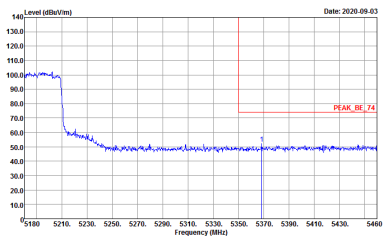
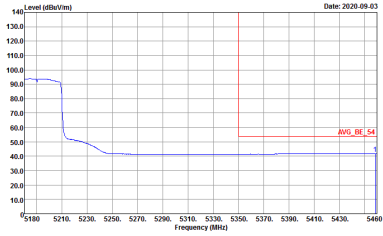

WIFI	Band 1 5150~5250MHz Band Edge @ 3m	
ANT	802.11ax HE40 Full CH38 5190MHz - R	
0+1	Vertical	Fundamental
<p>Peak</p>	 <p>Site : 03CH15-HY Condition : PEAK_BE_74 3m 9120D_15_1620 VERTICAL Detector : Peak Project : 041657</p>	<p>Left blank</p>
<p>Avg.</p>	 <p>Site : 03CH15-HY Condition : AVG_BE_54 3m 9120D_15_1620 VERTICAL Detector : Peak Project : 041657</p>	<p>Left blank</p>

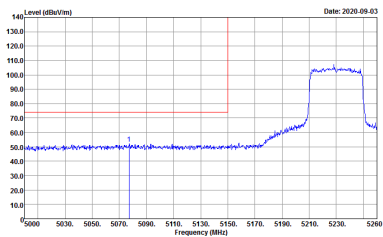
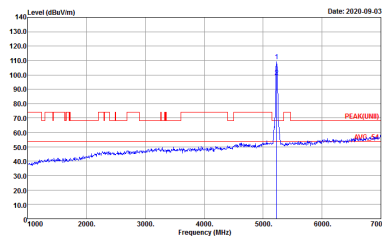
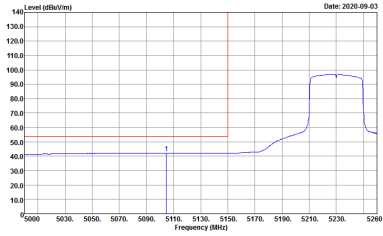

WIFI	Band 1 5150~5250MHz Band Edge @ 3m	
ANT	802.11ax HE40 Full CH46 5230MHz - L	
0+1	Horizontal	Fundamental
Peak	 <p>Date: 2020-09-03</p> <p>Site : 03CH15-HY Condition : PEAK_BE_74 3m 91200_15_1620 HORIZONTAL RBW:1000.000KHz VBW:3000.000KHz SWT:Auto Detector : Peak Project : 041657</p>	 <p>Date: 2020-09-03</p> <p>Site : 03CH15-HY Condition : PEAKUNII 3m 91200_15_1620 HORIZONTAL RBW:1000.000KHz VBW:3000.000KHz SWT:Auto Detector : Peak Project : 041657</p>
Avg.	 <p>Date: 2020-09-03</p> <p>Site : 03CH15-HY Condition : AVG_BE_54 3m 91200_15_1620 HORIZONTAL RBW:1000.000KHz VBW:3000.000KHz SWT:Auto Detector : Peak Project : 041657</p>	Left blank

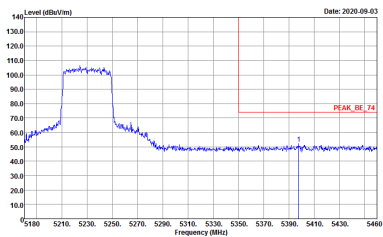
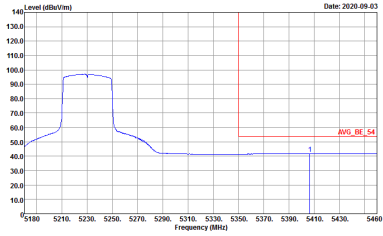

WIFI	Band 1 5150~5250MHz Band Edge @ 3m	
ANT	802.11ax HE40 Full CH46 5230MHz - R	
0+1	Horizontal	Fundamental
Peak	 <p>Site : 03CH15-HY Condition : PEAK_BE_74 3m 9120D_15_1620 HORIZONTAL Detector : Peak Project : 041657</p>	Left blank
Avg.	 <p>Site : 03CH15-HY Condition : AVG_BE_54 3m 9120D_15_1620 HORIZONTAL Detector : Peak Project : 041657</p>	Left blank

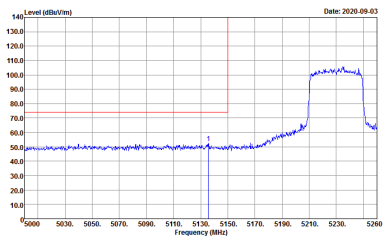
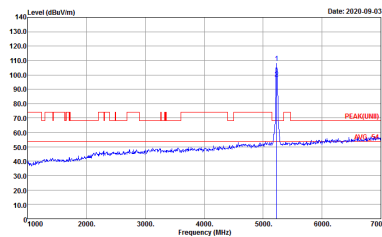
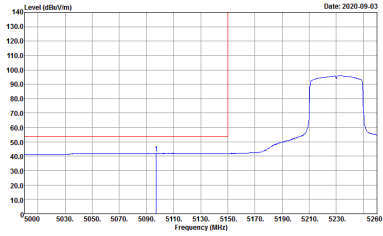

WIFI	Band 1 5150~5250MHz Band Edge @ 3m	
ANT	802.11ax HE40 Full CH46 5230MHz - L	
0+1	Vertical	Fundamental
Peak	 <p>Site : 03CH15-HY Condition : PEAK_BE_74 3m 91200_15_1620 VERTICAL Detector : Peak Project : 041657</p>	 <p>Site : 03CH15-HY Condition : PEAK(LINII) 3m 91200_15_1620 VERTICAL Detector : Peak Project : 041657</p>
Avg.	 <p>Site : 03CH15-HY Condition : AVG_BE_54 3m 91200_15_1620 VERTICAL Detector : Peak Project : 041657</p>	Left blank



WIFI	Band 1 5150~5250MHz Band Edge @ 3m	
ANT	802.11ax HE40 Full CH46 5230MHz - R	
0+1	Vertical	Fundamental
Peak	<p>Site : 03CH15-HY Condition : PEAK_BE_74 3m 9120D_15_1620 VERTICAL Detector : Peak Project : 041657</p>	Left blank
Avg.	<p>Site : 03CH15-HY Condition : AVG_BE_54 3m 9120D_15_1620 VERTICAL Detector : Peak Project : 041657</p>	Left blank

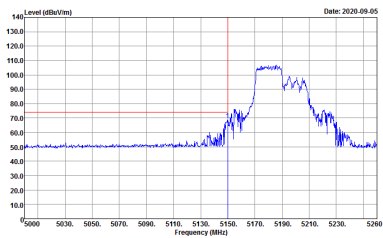
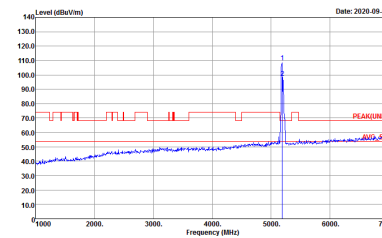
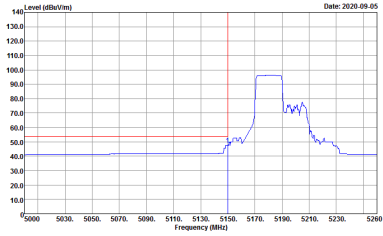

Band 1 5150~5250MHz
WIFI 802.11ax HE40 Partial 242 (Band Edge @ 3m)

WIFI	Band 1 5150~5250MHz Band Edge @ 3m	
ANT	802.11ax HE40 Partial 242/61 CH38 5190MHz - L	
0+1	Horizontal	Fundamental
Peak	 <p>Site : 03CH15-HY Condition : PEAK_BE_74 3m 91200_15_1620 HORIZONTAL RBW:1000.000KHz VBW:3000.000KHz SWT:Auto Detector : Peak Project : 041657</p>	 <p>Site : 03CH15-HY Condition : PEAK(UNIT) 3m 91200_15_1620 HORIZONTAL RBW:1000.000KHz VBW:3000.000KHz SWT:Auto Detector : Peak Project : 041657</p>
Avg.	 <p>Site : 03CH15-HY Condition : AVG_BE_54 3m 91200_15_1620 HORIZONTAL RBW:1000.000KHz VBW:0.010KHz SWT:Auto Detector : Peak Project : 041657</p>	Left blank

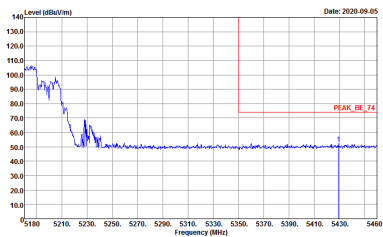
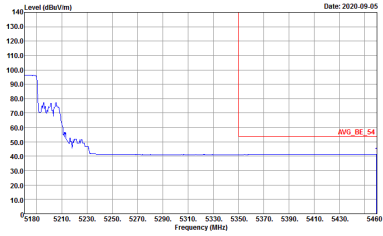

WIFI	Band 1 5150~5250MHz Band Edge @ 3m	
ANT	802.11ax HE40 Partial 242/61 CH38 5190MHz - R	
0+1	Horizontal	Fundamental
<p>Peak</p>	 <p>Site : 03CH15-HY Condition : PEAK_BE_74 3m 91200_15_1620 HORIZONTAL Detector : Peak Project : 041657</p>	<p>Left blank</p>
<p>Avg.</p>	 <p>Site : 03CH15-HY Condition : AVG_BE_54 3m 91200_15_1620 HORIZONTAL Detector : Peak Project : 041657</p>	<p>Left blank</p>

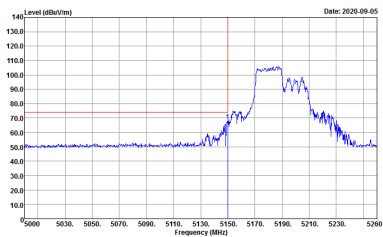
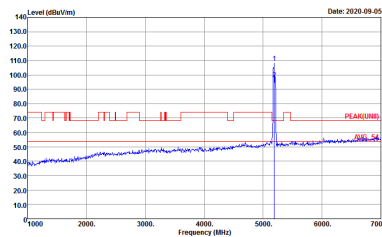
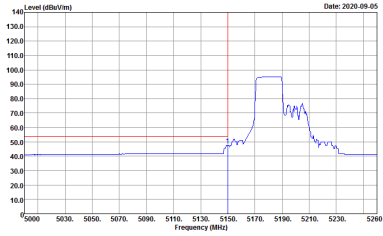

WIFI	Band 1 5150~5250MHz Band Edge @ 3m	
ANT	802.11ax HE40 Partial 242/61 CH38 5190MHz - L	
0+1	Vertical	Fundamental
<p>Peak</p>	 <p>Date: 2020-09-05</p> <p>Site : 03CH15-HY Condition : PEAK_BE_74 3m 91200_15_1620 VERTICAL RBW:1000.000kHz VBW:3000.000kHz SWT:Auto Detector : Peak Project : 041657</p>	 <p>Date: 2020-09-05</p> <p>Site : 03CH15-HY Condition : PEAK(LINII) 3m 91200_15_1620 VERTICAL RBW:1000.000kHz VBW:3000.000kHz SWT:Auto Detector : Peak Project : 041657</p>
<p>Avg.</p>	 <p>Date: 2020-09-05</p> <p>Site : 03CH15-HY Condition : AVG_BE_54 3m 91200_15_1620 VERTICAL RBW:1000.000kHz VBW:3000.000kHz SWT:Auto Detector : Peak Project : 041657</p>	<p>Left blank</p>



WIFI	Band 1 5150~5250MHz Band Edge @ 3m	
ANT	802.11ax HE40 Partial 242/61 CH38 5190MHz - R	
0+1	Vertical	Fundamental
Peak	<p>Site : 03CH15-HY Condition : PEAK_BE_74 3m 9120D_15_1620 VERTICAL Detector : Peak Project : 041657</p>	Left blank
Avg.	<p>Site : 03CH15-HY Condition : AVG_BE_54 3m 9120D_15_1620 VERTICAL Detector : Peak Project : 041657</p>	Left blank

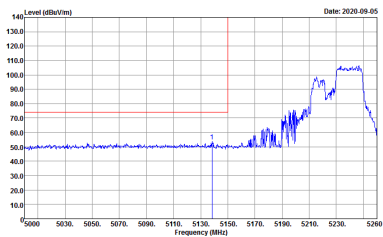
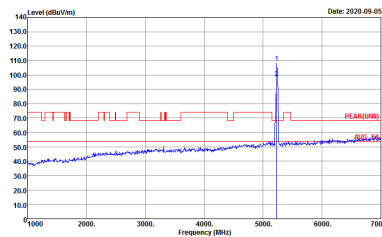
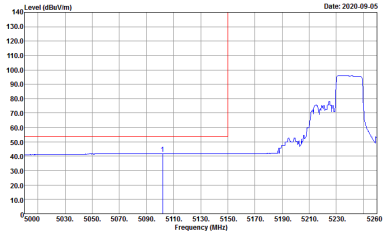

WIFI	Band 1 5150~5250MHz Band Edge @ 3m	
ANT	802.11ax HE40 Partial 242/62 CH46 5230MHz - L	
0+1	Horizontal	Fundamental
<p>Peak</p>	 <p>Date: 2020-09-05</p> <p>Site : 03CH15-HY Condition : PEAK_BE_74 3m 91200_15_1620 HORIZONTAL RBW:1000.000KHz VBW:3000.000KHz SWT:Auto Detector : Peak Project : 041657</p>	 <p>Date: 2020-09-05</p> <p>Site : 03CH15-HY Condition : PEAK(UNII) 3m 91200_15_1620 HORIZONTAL RBW:1000.000KHz VBW:3000.000KHz SWT:Auto Detector : Peak Project : 041657</p>
<p>Avg.</p>	 <p>Date: 2020-09-05</p> <p>Site : 03CH15-HY Condition : AVG_BE_54 3m 91200_15_1620 HORIZONTAL RBW:1000.000KHz VBW:3000.000KHz SWT:Auto Detector : Peak Project : 041657</p>	<p>Left blank</p>

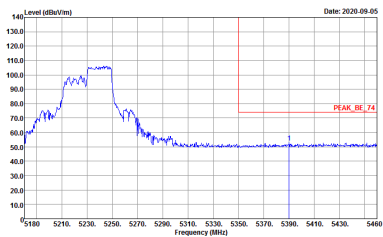
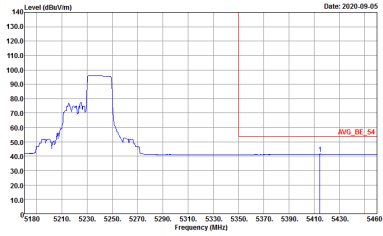

WIFI	Band 1 5150~5250MHz Band Edge @ 3m	
ANT	802.11ax HE40 Partial 242/62 CH46 5230MHz - R	
0+1	Horizontal	Fundamental
<p>Peak</p>	 <p>Site : 03CH15-HY Condition : PEAK_BE_74 3m 91200_15_1620 HORIZONTAL Detector : Peak Project : 041657</p>	<p>Left blank</p>
<p>Avg.</p>	 <p>Site : 03CH15-HY Condition : AVG_BE_54 3m 91200_15_1620 HORIZONTAL Detector : Peak Project : 041657</p>	<p>Left blank</p>

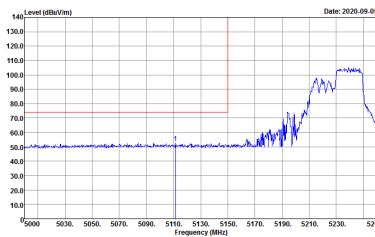
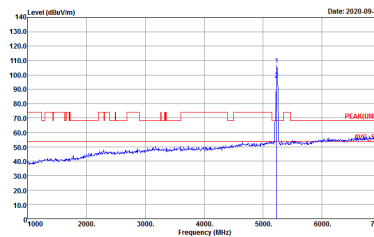
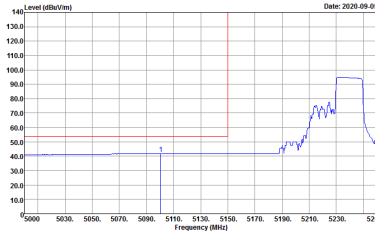

WIFI	Band 1 5150~5250MHz Band Edge @ 3m	
ANT	802.11ax HE40 Partial 242/62 CH46 5230MHz - L	
0+1	Vertical	Fundamental
Peak	 <p>Date: 2020-09-05</p> <p>Site : 03CH15-HY Condition : PEAK_BE_74 3m 91200_15_1620 VERTICAL : RBW:1000.000KHz VBW:3000.000KHz SWT:Auto Detector : Peak Project : 041657</p>	 <p>Date: 2020-09-05</p> <p>Site : 03CH15-HY Condition : PEAK(UNII) 3m 91200_15_1620 VERTICAL : RBW:1000.000KHz VBW:3000.000KHz SWT:Auto Detector : Peak Project : 041657</p>
Avg.	 <p>Date: 2020-09-05</p> <p>Site : 03CH15-HY Condition : AVG_BE_54 3m 91200_15_1620 VERTICAL : RBW:1000.000KHz VBW:3000.000KHz SWT:Auto Detector : Peak Project : 041657</p>	Left blank

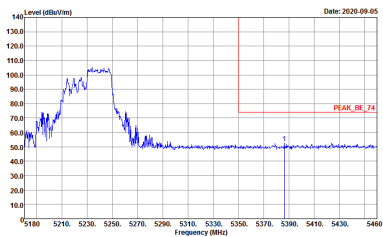
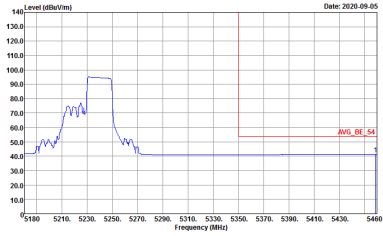

WIFI	Band 1 5150~5250MHz Band Edge @ 3m	
ANT	802.11ax HE40 Partial 242/62 CH46 5230MHz - R	
0+1	Vertical	Fundamental
<p>Peak</p>	 <p>Site : 03CH15-HY Condition : PEAK_BE_74 3m 9120D_15_1620 VERTICAL Detector : Peak Project : 041657</p>	<p>Left blank</p>
<p>Avg.</p>	 <p>Site : 03CH15-HY Condition : AVG_BE_54 3m 9120D_15_1620 VERTICAL Detector : Peak Project : 041657</p>	<p>Left blank</p>

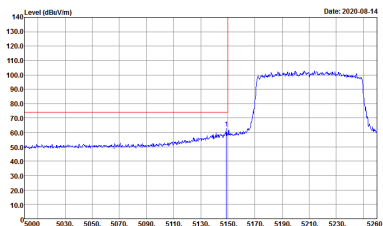
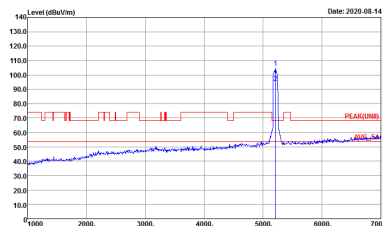
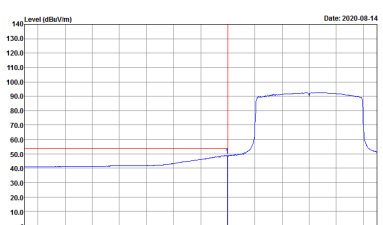

Band 1 5150~5250MHz
WIFI 802.11ax HE80 Full (Band Edge @ 3m)

WIFI	Band 1 5150~5250MHz Band Edge @ 3m	
ANT	802.11ax HE80 Full CH42 5210MHz - L	
0+1	Horizontal	Fundamental
Peak	 <p>Site : 03CH15-HY Condition : PEAK_BE_74 3m 91200_15_1620 HORIZONTAL RBW:1000.000KHz VBW:3000.000KHz SWT:Auto Detector : Peak Project : 041657</p>	 <p>Site : 03CH15-HY Condition : PEAK(UNIT) 3m 91200_15_1620 HORIZONTAL RBW:1000.000KHz VBW:3000.000KHz SWT:Auto Detector : Peak Project : 041657</p>
Avg.	 <p>Site : 03CH15-HY Condition : AVG_BE_54 3m 91200_15_1620 HORIZONTAL RBW:1000.000KHz VBW:0.010KHz SWT:Auto Detector : Peak Project : 041657</p>	Left blank



WIFI	Band 1 5150~5250MHz Band Edge @ 3m	
ANT	802.11ax HE80 Full CH42 5210MHz - R	
0+1	Horizontal	Fundamental
Peak	<p>Site : 03CH15-HY Condition : PEAK_BE_74 3m 91200_15_1620 HORIZONTAL Detector : Peak Project : 041657</p>	Left blank
Avg.	<p>Site : 03CH15-HY Condition : AVG_BE_54 3m 91200_15_1620 HORIZONTAL Detector : Peak Project : 041657</p>	Left blank

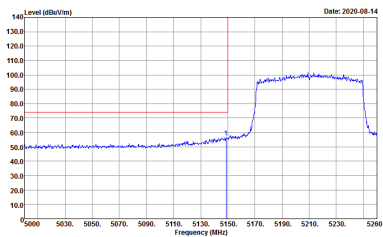
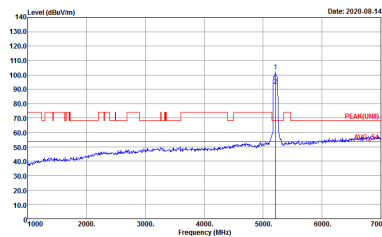
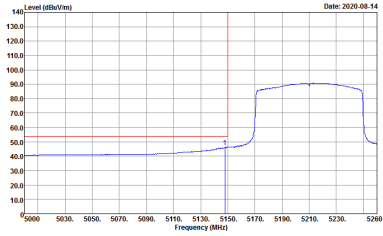

WIFI	Band 1 5150~5250MHz Band Edge @ 3m	
ANT	802.11ax HE80 Full CH42 5210MHz - L	
0+1	Vertical	Fundamental
Peak	 <p>Date: 2020-08-14</p> <p>Site : 03CH15-HY Condition : PEAK_BE_74 3m 91200_15_1620 VERTICAL RBW:1000.000KHz VBW:3000.000KHz SWT:Auto Detector : Peak Project : 041657</p>	 <p>Date: 2020-08-14</p> <p>Site : 03CH15-HY Condition : PEAK(LINII) 3m 91200_15_1620 VERTICAL RBW:1000.000KHz VBW:3000.000KHz SWT:Auto Detector : Peak Project : 041657</p>
Avg.	 <p>Date: 2020-08-14</p> <p>Site : 03CH15-HY Condition : AVG_BE_54 3m 91200_15_1620 VERTICAL RBW:1000.000KHz VBW:3000.000KHz SWT:Auto Detector : Peak Project : 041657</p>	Left blank

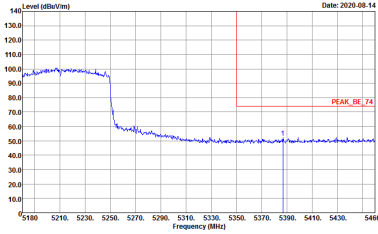
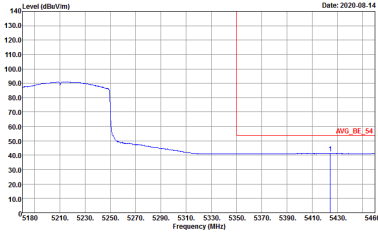

WIFI	Band 1 5150~5250MHz Band Edge @ 3m	
ANT	802.11ax HE80 Full CH42 5210MHz - R	
0+1	Vertical	Fundamental
Peak	 <p>Site : 03CH15+HY Condition : PEAK_BE_74 3m 91200_15_1620 VERTICAL : RBW:1000.000KHz VBW:3000.000KHz SWT:Auto Detector : Peak Project : 041657</p>	Left blank
Avg.	 <p>Site : 03CH15+HY Condition : AVG_BE_54 3m 91200_15_1620 VERTICAL : RBW:1000.000KHz VBW:0.010KHz SWT:Auto Detector : Peak Project : 041657</p>	Left blank

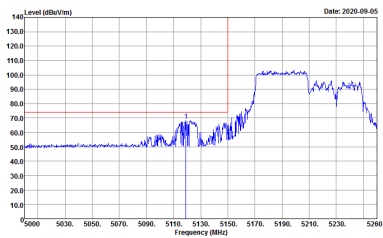
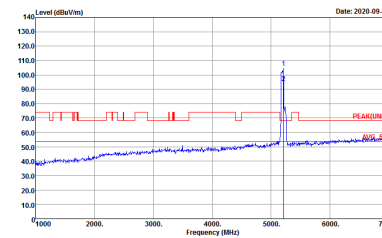
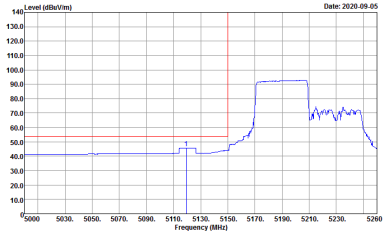

Band 1 5150~5250MHz
WIFI 802.11ax HE80 Partial 242 (Band Edge @ 3m)

WIFI	Band 1 5150~5250MHz Band Edge @ 3m	
ANT	802.11ax HE80 Partial 484/65 CH42 5210MHz - L	
0+1	Horizontal	Fundamental
Peak	 <p>Site : 03CH15-HY Condition : PEAK_BE_74 3m 91200_15_1620 HORIZONTAL : RBW:1000.000KHz VBW:3000.000KHz SWT:Auto Detector : Peak Project : 041657</p>	 <p>Site : 03CH15-HY Condition : PEAK(UNIT) 3m 91200_15_1620 HORIZONTAL : RBW:1000.000KHz VBW:3000.000KHz SWT:Auto Detector : Peak Project : 041657</p>
Avg.	 <p>Site : 03CH15-HY Condition : AVG_BE_54 3m 91200_15_1620 HORIZONTAL : RBW:1000.000KHz VBW:0.010KHz SWT:Auto Detector : Peak Project : 041657</p>	Left blank

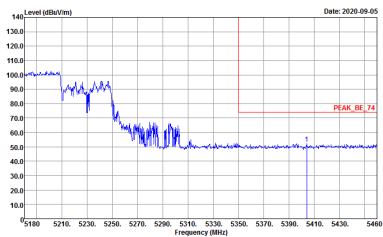
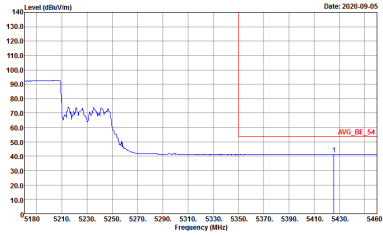

WIFI	Band 1 5150~5250MHz Band Edge @ 3m	
ANT	802.11ax HE80 Partial 484/65CH42 5210MHz - R	
0+1	Horizontal	Fundamental
<p>Peak</p>	 <p>Site : 03CH15-HY Condition : PEAK_BE_74 3m 91200_15_1620 HORIZONTAL Detector : Peak Project : 041657</p>	<p>Left blank</p>
<p>Avg.</p>	 <p>Site : 03CH15-HY Condition : AVG_BE_54 3m 91200_15_1620 HORIZONTAL Detector : Peak Project : 041657</p>	<p>Left blank</p>

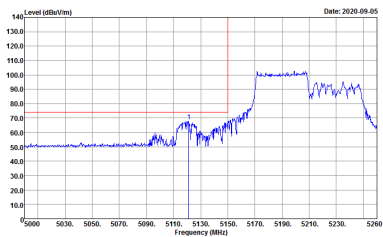
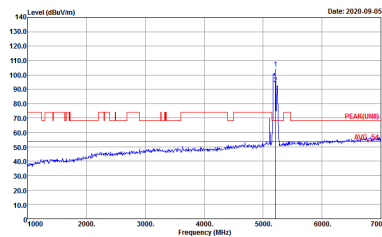
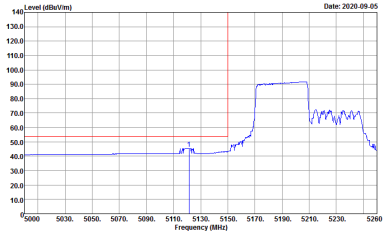

WIFI	Band 1 5150~5250MHz Band Edge @ 3m	
ANT	802.11ax HE80 Partial 484/65 CH42 5210MHz - L	
0+1	Vertical	Fundamental
<p>Peak</p>	 <p>Date: 2020-09-05</p> <p>Site : 03CH15-HY Condition : PEAK_BE_74 3m 91200_15_1620 VERTICAL : RBW:1000.000KHz VBW:3000.000KHz SWT:Auto Detector : Peak Project : -041657</p>	 <p>Date: 2020-09-05</p> <p>Site : 03CH15-HY Condition : PEAK(UNII) 3m 91200_15_1620 VERTICAL : RBW:1000.000KHz VBW:3000.000KHz SWT:Auto Detector : Peak Project : -041657</p>
<p>Avg.</p>	 <p>Date: 2020-09-05</p> <p>Site : 03CH15-HY Condition : AVG_BE_54 3m 91200_15_1620 VERTICAL : RBW:1000.000KHz VBW:3000.000KHz SWT:Auto Detector : Peak Project : -041657</p>	<p>Left blank</p>

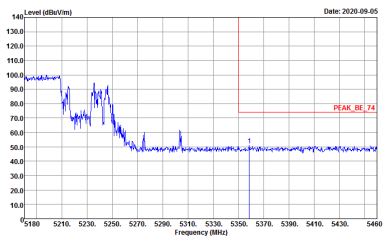
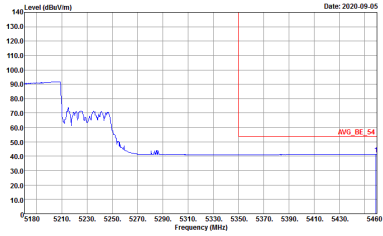

WIFI	Band 1 5150~5250MHz Band Edge @ 3m	
ANT	802.11ax HE80 Partial 484/65 CH42 5210MHz - R	
0+1	Vertical	Fundamental
<p>Peak</p>	 <p>Site : 03CH15-HY Condition : PEAK_BE_74 3m 9120D_15_1620 VERTICAL Detector : Peak Project : 041657</p>	<p>Left blank</p>
<p>Avg.</p>	 <p>Site : 03CH15-HY Condition : AVG_BE_54 3m 9120D_15_1620 VERTICAL Detector : Peak Project : 041657</p>	<p>Left blank</p>



WIFI	Band 1 5150~5250MHz Band Edge @ 3m	
ANT	802.11ax HE80 Partial 484/66 CH42 5210MHz - L	
0+1	Horizontal	Fundamental
<p>Peak</p>	<p>Site : 03CH15-HY Condition : PEAK_BE_74 3m 91200_15_1620 HORIZONTAL Detector : Peak Project : 041657</p>	<p>Site : 03CH15-HY Condition : PEAK(UNII) 3m 91200_15_1620 HORIZONTAL Detector : Peak Project : 041657</p>
<p>Avg.</p>	<p>Site : 03CH15-HY Condition : AVG_BE_54 3m 91200_15_1620 HORIZONTAL Detector : Peak Project : 041657</p>	<p>Left blank</p>

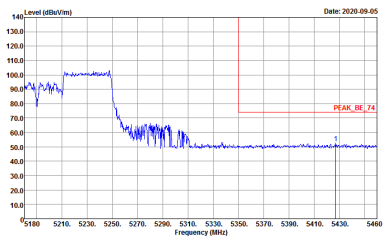
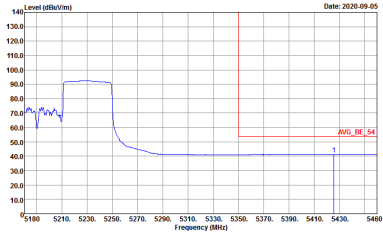

WIFI	Band 1 5150~5250MHz Band Edge @ 3m	
ANT	802.11ax HE80 Partial 484/66 CH42 5210MHz - R	
0+1	Horizontal	Fundamental
Peak	 <p>Site : 03CH15-HY Condition : PEAK_BE_74 3m 91200_15_1620 HORIZONTAL Detector : Peak Project : 041657</p>	Left blank
Avg.	 <p>Site : 03CH15-HY Condition : AVG_BE_54 3m 91200_15_1620 HORIZONTAL Detector : Peak Project : 041657</p>	Left blank

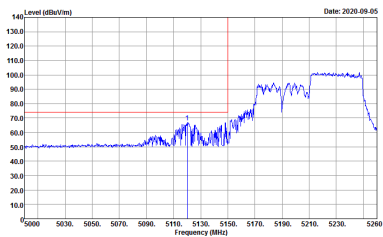
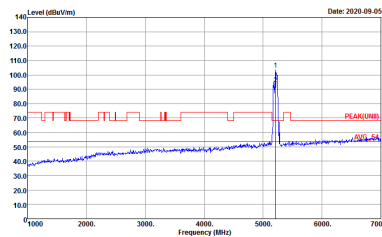
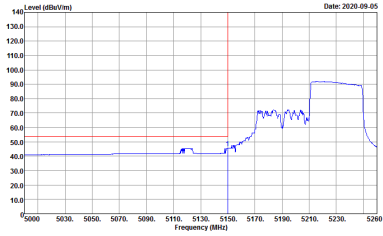

WIFI	Band 1 5150~5250MHz Band Edge @ 3m	
ANT	802.11ax HE80 Partial 484/66 CH42 5210MHz - L	
0+1	Vertical	Fundamental
<p>Peak</p>	 <p>Date: 2020-09-05</p> <p>Site : 03CH15-HY Condition : PEAK_BE_74 3m 91200_15_1620 VERTICAL RBW:1000.000KHz VBW:3000.000KHz SWT:Auto Detector : Peak Project : -041657</p>	 <p>Date: 2020-09-05</p> <p>Site : 03CH15-HY Condition : PEAK(LINII) 3m 91200_15_1620 VERTICAL RBW:1000.000KHz VBW:3000.000KHz SWT:Auto Detector : Peak Project : -041657</p>
<p>Avg.</p>	 <p>Date: 2020-09-05</p> <p>Site : 03CH15-HY Condition : AVG_BE_54 3m 91200_15_1620 VERTICAL RBW:1000.000KHz VBW:3000.000KHz SWT:Auto Detector : Peak Project : -041657</p>	<p>Left blank</p>

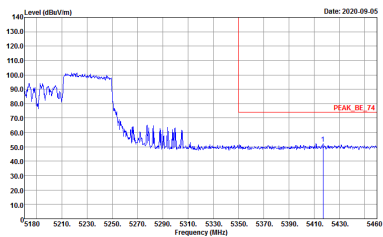
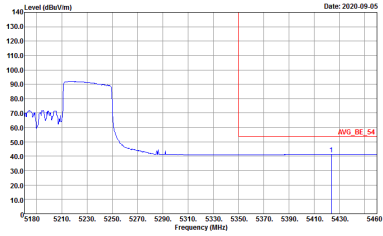

WIFI	Band 1 5150~5250MHz Band Edge @ 3m	
ANT	802.11ax HE80 Partial 484/66 CH42 5210MHz - R	
0+1	Vertical	Fundamental
<p>Peak</p>	 <p>Site : 03CH15-HY Condition : PEAK_BE_74 3m 9120D_15_1620 VERTICAL Detector : Peak Project : 041657</p>	<p>Left blank</p>
<p>Avg.</p>	 <p>Site : 03CH15-HY Condition : AVG_BE_54 3m 9120D_15_1620 VERTICAL Detector : Peak Project : 041657</p>	<p>Left blank</p>



Band 1 - 5150~5250MHz

WIFI 802.11a (Harmonic @ 3m)

WIFI	Band 1 5150~5250MHz Harmonic @ 3m	
ANT	802.11a CH36 5180MHz	
0+1	Horizontal	Vertical
Peak Avg.	<p>Site : 03CH15-HY Condition : PEAR(LINE1) 3m 91200_15_1620 HORIZONTAL Detector : Peak Project : 041657</p>	<p>Site : 03CH15-HY Condition : PEAR(LINE1) 3m 91200_15_1620 VERTICAL Detector : Peak Project : 041657</p>



WIFI	Band 1 5150~5250MHz Harmonic @ 3m	
ANT	802.11a CH44 5220MHz	
0+1	Horizontal	Vertical
Peak Avg.	<p>Site : 03CH15-11Y Condition : PEAK(LINE1) 3m 9120D_15_1620 HORIZONTAL Detector : Peak Project : 041657</p>	<p>Site : 03CH15-11Y Condition : PEAK(LINE1) 3m 9120D_15_1620 VERTICAL Detector : Peak Project : 041657</p>



WIFI	Band 1 5150~5250MHz Harmonic @ 3m	
ANT	802.11a CH48 5240MHz	
0+1	Horizontal	Vertical
Peak Avg.	<p>Site : 03CH15-11Y Condition : PEAK(LINE1) 3m 9120D_15_1620 HORIZONTAL Detector : Peak Project : 041657</p>	<p>Site : 03CH15-11Y Condition : PEAK(LINE1) 3m 9120D_15_1620 VERTICAL Detector : Peak Project : 041657</p>



**Band 1 5150~5250MHz
WIFI 802.11ax HE20 Full (Harmonic @ 3m)**

WIFI	Band 1 5150~5250MHz Harmonic @ 3m	
ANT	802.11ax HE20 Full CH36 5180MHz	
0+1	Horizontal	Vertical
Peak Avg.	<p>Site : 03CH15-HY Condition : PEAK(LIMIT) 3m 91200_15_1620 HORIZONTAL Detector : Peak Project : 041657</p>	<p>Site : 03CH15-HY Condition : PEAK(LIMIT) 3m 91200_15_1620 VERTICAL Detector : Peak Project : 041657</p>



WIFI	Band 1 5150~5250MHz Harmonic @ 3m	
ANT	802.11ax HE20 Full CH44 5220MHz	
0+1	Horizontal	Vertical
Peak Avg.	<p>Site : 03CH15-11Y Condition : PEAK(LINE1) 3m 9120D_15_1620 HORIZONTAL Detector : Peak Project : 041657</p>	<p>Site : 03CH15-11Y Condition : PEAK(LINE1) 3m 9120D_15_1620 VERTICAL Detector : Peak Project : 041657</p>

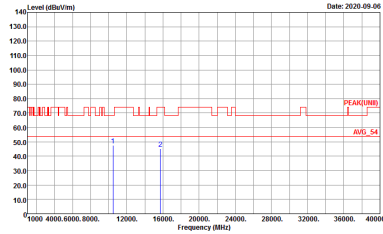
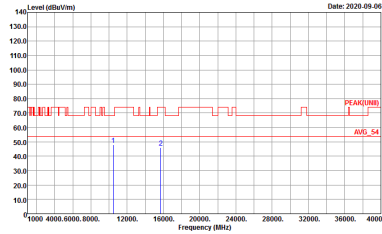

WIFI	Band 1 5150~5250MHz Harmonic @ 3m	
ANT	802.11ax HE20 Full CH48 5240MHz	
0+1	Horizontal	Vertical
<p>Peak</p> <p>Avg.</p>	 <p>Site : 03CH15-11Y Condition : PEAK(LINE1) 3m 91200_15_1620 HORIZONTAL Detector : Peak Project : 041657</p>	 <p>Site : 03CH15-11Y Condition : PEAK(LINE1) 3m 91200_15_1620 VERTICAL Detector : Peak Project : 041657</p>



Band 1 5150~5250MHz
WIFI 802.11ax HE40 Full (Harmonic @ 3m)

Table with 2 columns: Horizontal and Vertical. Each column contains a spectral plot showing Level (dBm/100MHz) vs Frequency (MHz) with peak and average markers. Includes metadata like Site, Condition, Detector, and Project.



WIFI	Band 1 5150~5250MHz Harmonic @ 3m	
ANT	802.11ax HE40 Full CH46 5230MHz	
0+1	Horizontal	Vertical
Peak Avg.	<p>Site : 03CH15-11Y Condition : PEAK(LINE1) 3m 9120D_15_1620 VERTICAL Detector : Peak Project : 041657</p>	<p>Site : 03CH15-11Y Condition : PEAK(LINE1) 3m 9120D_15_1620 VERTICAL Detector : Peak Project : 041657</p>



Band 1 5150~5250MHz
WIFI 802.11ax HE80 Full (Harmonic @ 3m)

Table with 2 columns: Horizontal and Vertical. Each column contains a spectral plot of Level (dBm/100MHz) vs Frequency (MHz) and associated test parameters like Site, Condition, Detector, and Project.



Emission below 1GHz
5GHz WIFI 802.11ax HE80 Full (LF)

WIFI	5GHz WIFI	
ANT	802.11ax HE80 Full LF	
0+1	Horizontal	Vertical
QP / Peak	<p>Site : 03CH15-11Y Condition : QP 3m B1LOG_15_41912 HORIZONTAL Detector : Peak Project : 041657</p>	<p>Site : 03CH15-11Y Condition : QP 3m B1LOG_15_41912 VERTICAL Detector : Peak Project : 041657</p>



Appendix E. Duty Cycle Plots

Antenna	Band	Duty Cycle(%)	T(us)	1/T(kHz)	VBW Setting	Duty Factor(dB)
0+1	802.11a for Ant 0	98.51	-	-	10Hz	0.07
0+1	802.11a for Ant 1	98.50	-	-	10Hz	0.07
0+1	5GHz 802.11ax HE20 Full RU for Ant 0	100.00	-	-	10Hz	0.00
0+1	5GHz 802.11ax HE20 Full RU for Ant 1	100.00	-	-	10Hz	0.00
0+1	5GHz 802.11ax HE40 Full RU for Ant 0	100.00	-	-	10Hz	0.00
0+1	5GHz 802.11ax HE40 Full RU for Ant 1	100.00	-	-	10Hz	0.00
0+1	5GHz 802.11ax HE80 Full RU for Ant 0	100.00	-	-	10Hz	0.00
0+1	5GHz 802.11ax HE80 Full RU for Ant 1	100.00	-	-	10Hz	0.00



MIMO<Ant. 0>

802.11a

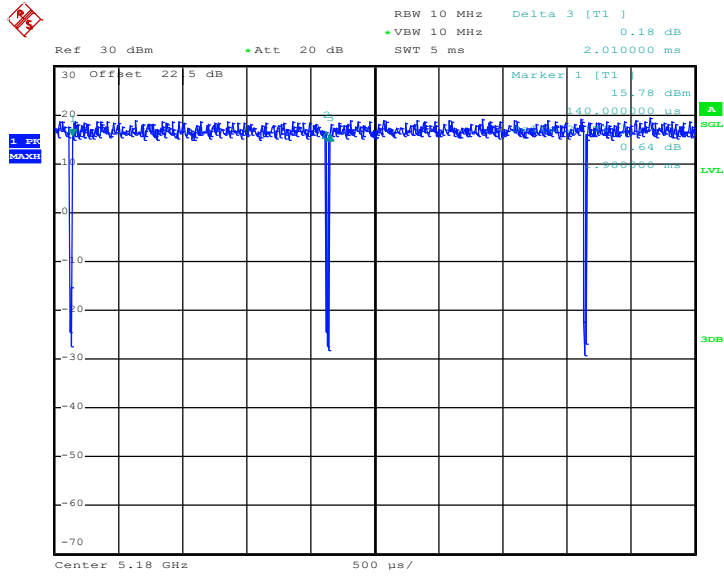

Date: 27.JUL.2020 13:48:35

802.11ax HE20 Full RU

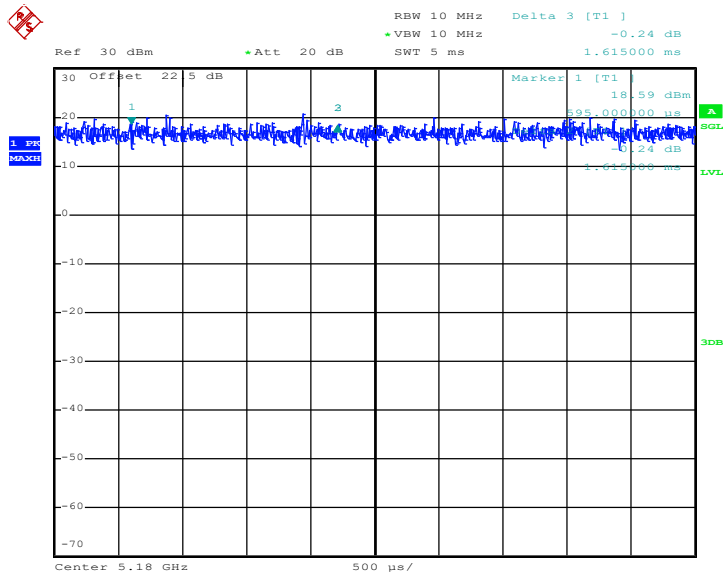

Date: 27.JUL.2020 11:04:06



802.11ax HE40 Full RU

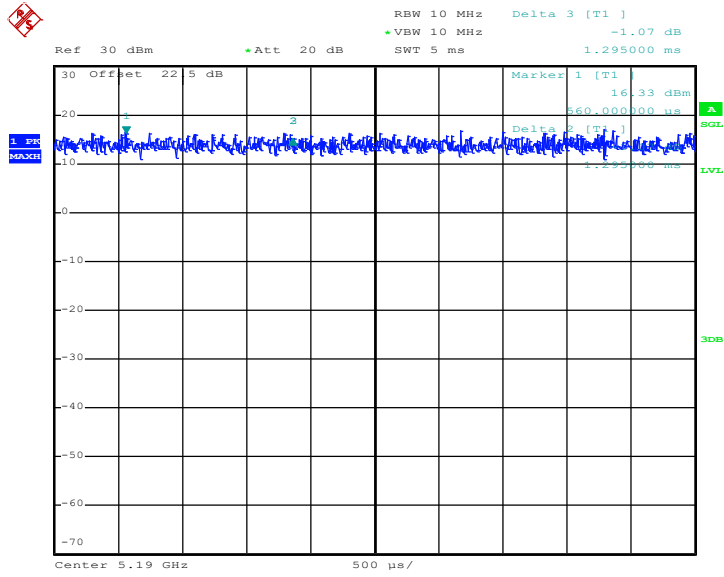

Date: 27.JUL.2020 11:18:51

802.11ax HE80 Full RU

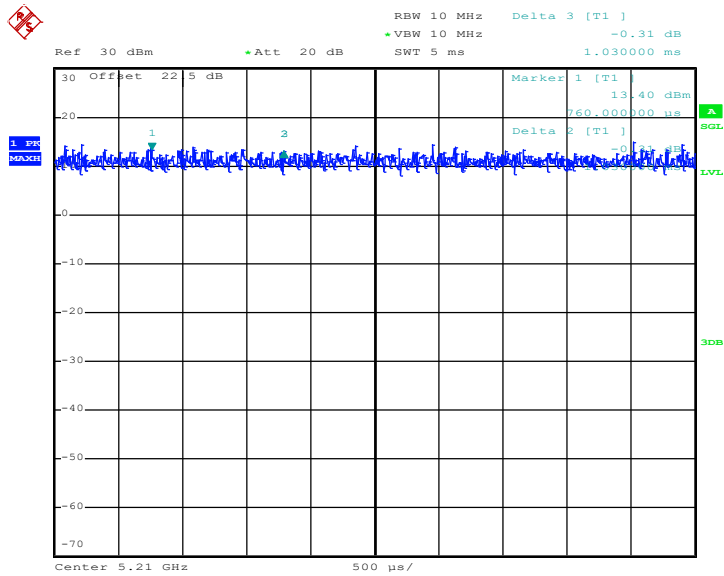

Date: 27.JUL.2020 11:27:37



MIMO<Ant. 1>

802.11a

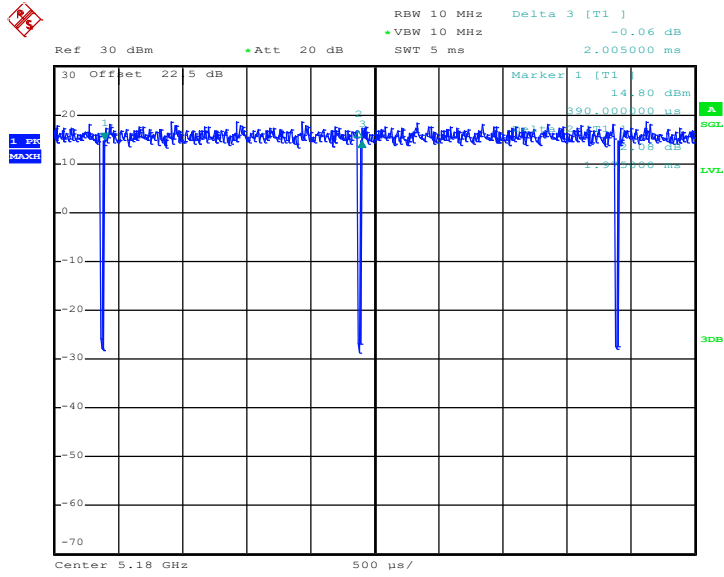

Date: 27.JUL.2020 13:47:07

802.11ax HE20 Full RU

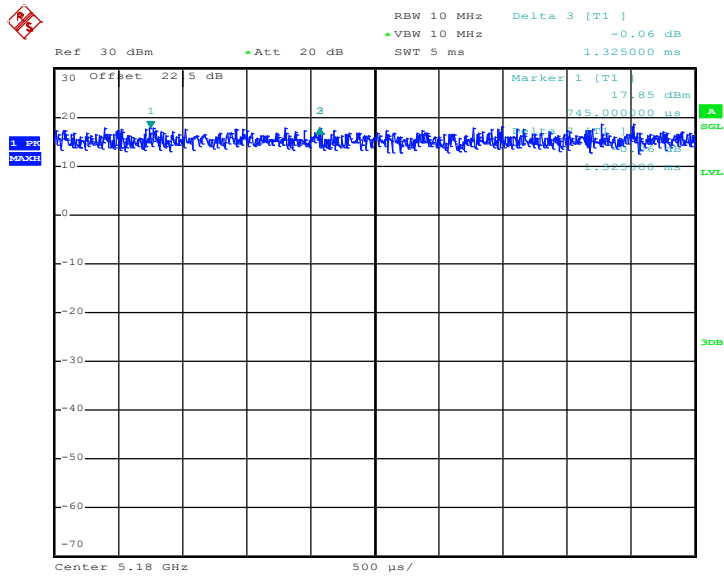

Date: 27.JUL.2020 11:05:38



802.11ax HE40 Full RU

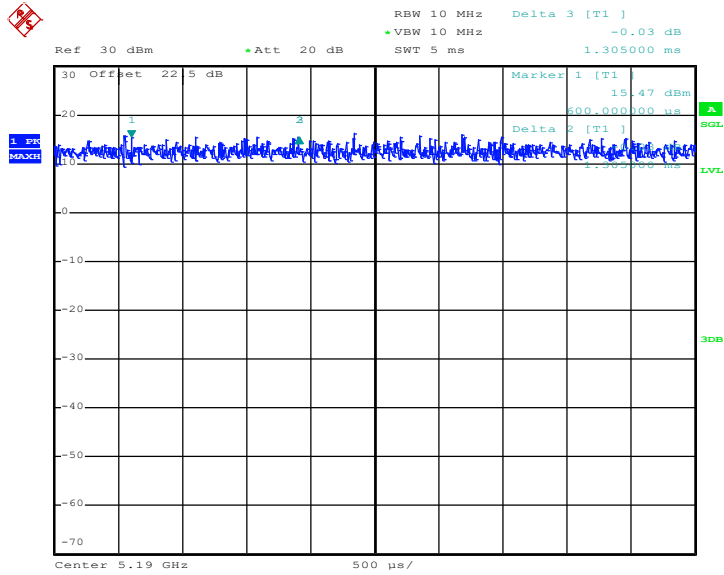

Date: 27.JUL.2020 11:17:58

802.11ax HE80 Full RU

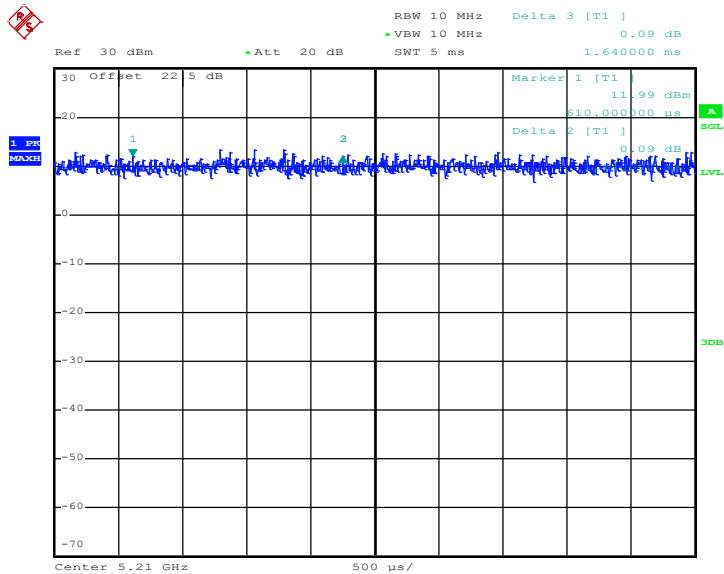

Date: 27.JUL.2020 11:29:20