

RF Exposure Lab

802 N. Twin Oaks Valley Road, Suite 105 • San Marcos, CA 92069 • U.S.A.

TEL (760) 471-2100 • FAX (760) 471-2121

<http://www.rfexposurelab.com>

CERTIFICATE OF COMPLIANCE SAR EVALUATION

Inseego
9645 Scranton Road, Suite 205
San Diego, CA 92121

Dates of Test: February 11-April 9, May 7, 2019
Test Report Number: SAR.20190423
Revision E

FCC ID:	PKRISGM1000
IC Certificate:	3229A-M1000
Model(s):	M1000
Test Sample:	Engineering Unit Same as Production
FID Number:	FF161218B00028, FF161218B00059, FF130219B00637
Equipment Type:	Wireless Hotspot Modem
Classification:	Portable Transmitter Next to Body
TX Frequency Range:	777 – 787 MHz, 824 – 848 MHz; 1710 – 1780 MHz; 1850 – 1910 MHz, 3550 – 3700 MHz, 2412 – 2462 MHz, 5150 – 5250 MHz, 5745 – 5825 MHz
Frequency Tolerance:	± 2.5 ppm
Maximum RF Output:	750 MHz (LTE) – 24.0 dBm, 850 MHz (WCDMA) – 24.0 dBm, 850 MHz (LTE) – 24.0 dBm, 1750 MHz (WCDMA) – 24.0 dBm, 1750 MHz (LTE) – 23.0 dBm, 1900 MHz (WCDMA) – 24.0 dBm, 1900 MHz (LTE) – 22.5 dBm, 3600 MHz (LTE) – 24.0 dBm, 2450 MHz (b) – 14.0 dBm, 2450 MHz(g/n) – 14.0 dBm, 5100 MHz (an/ac) – 14.0 dBm, 5800 MHz (an/ac) – 14.0 dBm Conducted
Signal Modulation:	WCDMA, QPSK, 16QAM, DSSS, OFDM
Antenna Type:	WWAN – Novatel Wireless, P/N 12023244 (Ant0), P/N 12023245 (Ant1), P/N 12023246 (Ant2) P/N 12023247 (Ant3), P/N 12023248 (Ant4), P/N 12023249 (Ant5), P/N Itched on PCB (Ant6), P/N 12023250 (Ant7), P/N 12023251 (WLAN0), P/N 12023252 (WLAN1), P/N 31325791 (mmW)
Application Type:	Certification
FCC Rule Parts:	Part 2, 15C, 15E, 22, 24, 27
KDB Test Methodology:	KDB 447498 D01 v06, KDB 248227 v02r02, KDB 941225 D01 v03r01, D02 v02r01, D05 v02r01 & D06 v01
Industry Canada:	RSS-102 Issue 5, Safety Code 6
Max. Stand Alone SAR Value:	1.18 W/kg Reported
Max. Simultaneous SAR Value:	91.1% Ratio of Limit for SAR and Power Density
Separation Distance:	10 mm

This wireless mobile and/or portable device has been shown to be compliant for localized specific absorption rate (SAR) for uncontrolled environment/general exposure limits specified in ANSI/IEEE Std. C95.1-1992 and had been tested in accordance with the measurement procedures specified in IEEE 1528-2013 and IEC 62209-2:2010 (See test report).

I attest to the accuracy of the data. All measurements were performed by myself or were made under my supervision and are correct to the best of my knowledge and belief. I assume full responsibility for the completeness of these measurements and vouch for the qualifications of all persons taking them.

RF Exposure Lab, LLC certifies that no party to this application is subject to a denial of Federal benefits that includes FCC benefits pursuant to Section 5301 of the Anti-Drug Abuse Act of 1988, 21 U.S.C. 853(a).



Jay M. Moulton
Vice President



Testing Cert. # 2387.01

© 2019 RF Exposure Lab, LLC

This report shall not be reproduced except in full without the written approval of RF Exposure Lab, LLC.

Table of Contents

1.	Introduction.....	3
	SAR Definition [5].....	5
2.	SAR Measurement Setup.....	6
	Robotic System.....	6
	System Hardware.....	6
	System Electronics.....	7
	Probe Measurement System.....	7
3.	Probe and Dipole Calibration.....	14
4.	Phantom & Simulating Tissue Specifications.....	15
	Head & Body Simulating Mixture Characterization.....	15
5.	ANSI/IEEE C95.1 – 1992 RF Exposure Limits [2].....	16
	Uncontrolled Environment.....	16
	Controlled Environment.....	16
6.	Measurement Uncertainty.....	17
7.	System Validation.....	18
	Tissue Verification.....	18
	Test System Verification.....	19
8.	LTE Document Checklist.....	20
9.	SAR Test Data Summary.....	25
	Procedures Used To Establish Test Signal.....	25
	Device Test Condition.....	25
10.	FCC 3G Measurement Procedures.....	27
	10.1 Procedures Used to Establish RF Signal for SAR.....	27
	10.2 SAR Measurement Conditions for WCDMA/HSDPA/HSUPA.....	27
	10.5 SAR Measurement Conditions for LTE Bands.....	48
	SAR Data Summary – 750 MHz Body – LTE Band 13.....	82
	SAR Data Summary – 835 MHz Body - WCDMA.....	83
	SAR Data Summary – 835 MHz Body – LTE Band 5.....	84
	SAR Data Summary – 1750 MHz Body - WCDMA.....	85
	SAR Data Summary – 1750 MHz Body – LTE Band 66.....	86
	SAR Data Summary – 1900 MHz Body - WCDMA.....	87
	SAR Data Summary – 1900 MHz Body – LTE Band 2.....	88
	SAR Data Summary – 3600 MHz Body – LTE Band 48.....	89
	SAR Data Summary – 2450 MHz Body 802.11b.....	90
	SAR Data Summary – 5200 MHz Body 802.11a.....	91
	SAR Data Summary – 5800 MHz Body 802.11a.....	92
	SAR Data Summary – Simultaneous Transmit (Worst Case) Ant 0 – WiFi.....	93
	SAR Data Summary – Simultaneous Transmit (Worst Case) Ant 4 – WiFi.....	93
	Carrier Aggregation Evaluation.....	94
	Table 1 – Carrier Aggregation Downlink Combinations.....	95
	Table 2 – SAR Data Summary – Body – LTE Bands 2, 4, 5, 13, 48, 66 Stand Alone SAR with Maximum TX Power Set to CA Power Level.....	96
	Table 3 – SAR Data Summary –Uplink CA Inter-Band (Per Fall 2018 TCB Workshop Notes).....	96
	Table 4 – SAR Data Summary –Uplink CA Intra-Band.....	97
	SAR Data Summary – Simultaneous Transmit 4G/WiFi/5G.....	98
11.	Test Equipment List.....	99
12.	Conclusion.....	100
13.	References.....	101
	Appendix A – System Validation Plots and Data.....	102
	Appendix B – SAR Test Data Plots.....	147
	Appendix C – SAR Test Setup Photos.....	160
	Appendix D – Probe Calibration Data Sheets.....	168
	Appendix E – Dipole Calibration Data Sheets.....	190
	Appendix F – Phantom Calibration Data Sheets.....	260
	Appendix G – Validation Summary.....	262
	Appendix H – Carrier Aggregation & MIMO Downlink Conducted Powers.....	263

1. Introduction

This measurement report shows compliance of the Novatel Wireless Model M1000 FCC ID: PKRISGM1000 with FCC Part 2, 1093, ET Docket 93-62 Rules for mobile and portable devices and IC Certificate: 3229A-M1000 with RSS102 Issue 5 & Safety Code 6. The FCC has adopted the guidelines for evaluating the environmental effects of radio frequency radiation in ET Docket 93-62 on August 6, 1996 to protect the public and workers from the potential hazards of RF emissions due to FCC regulated portable devices. [1], [6]

The test results recorded herein are based on a single type test of Novatel Wireless Model M1000 and therefore apply only to the tested sample.

The test procedures, as described in ANSI C95.1 – 1999 Standard for Safety Levels with Respect to Human Exposure to Radio Frequency Electromagnetic Fields, 3 kHz to 300 GHz [2], ANSI C95.3 – 2002 Recommended Practice for the Measurement of Potentially Hazardous Electromagnetic Fields [3], IEEE Std.1528 – 2013 Recommended Practice [4], and Industry Canada Safety Code 6 Limits of Human Exposure to Radiofrequency Electromagnetic Fields in the Frequency Range from 3kHz to 300 GHz were employed.

The following table indicates all the wireless technologies operating in the M1000 wireless modem. The table also shows the tolerance for the power level for each mode.

Band	Technology	Class	3GPP Nominal Power dBm	Calibrated Nominal Power dBm	Tolerance dBm	Lower Tolerance dBm	Upper Tolerance dBm
Band 2 – 1900 MHz	LTE	3	23.0	22.0	+0.5/-1.7	20.3	22.5
Band 4 – 1750 MHz	LTE	3	23.0	22.0	+1.0/-1.7	20.3	23.0
Band 5 – 835 MHz	LTE	3	23.0	23.0	+1.0/-1.7	21.3	24.0
Band 13 – 750 MHz	LTE	3	23.0	23.0	+1.0/-1.7	21.3	24.0
Band 66 – 1750 MHz	LTE	3	23.0	22.0	+1.0/-1.7	20.3	23.0
Band 48 – 3600 MHz	LTE-TDD	3	23.0	23.0	+1.0/-1.7	21.3	24.0
Band 2 – 1900 MHz	WCDMA/HSPA	3	23.0	23.0	+1.0/-2.0	21.0	24.0
Band 4 – 1750 MHz	WCDMA/HSPA	3	23.0	23.0	+1.0/-2.0	21.0	24.0
Band 5 – 850 MHz	WCDMA/HSPA	3	23.0	23.0	+1.0/-2.0	21.0	24.0
WLAN – 2.4 GHz	802.11b	N/A	N/A	12.0	±2.0	10.0	14.0
WLAN – 2.4 GHz	802.11g/n	N/A	N/A	12.0	±2.0	10.0	14.0
WLAN – 5.2 GHz	802.11an/ac	N/A	N/A	12.0	±2.0	10.0	14.0
WLAN – 5.8 GHz	802.11an/ac	N/A	N/A	12.0	±2.0	10.0	14.0
5G – mmW	LTE-TDD	3	N/A	N/A	N/A	N/A	14.0

Band UL 2CA Combination	Technology	Paired Spectrum	Class	3GPP Nominal	INSG Nominal	Tolerances	INSG Lower	INSG Upper
2A-5A	LTE	FDD	3	20	20	+1.0/-1.7	18.3	21
2A-13A	LTE	FDD	3	20	20	+1.0/-1.7	18.3	21
4A-5A	LTE	FDD	3	20	20	+1.0/-1.7	18.3	21
4A-13A	LTE	FDD	3	20	20	+1.0/-1.7	18.3	21
5B	LTE	FDD	3	20	20	+1.0/-1.7	18.3	21
66B	LTE	FDD	3	20	20	+1.0/-1.7	18.3	21
66C	LTE	FDD	3	20	20	+1.0/-1.7	18.3	21
5A-66A	LTE	FDD	3	20	20	+1.0/-1.7	18.3	21
13A-66A	LTE	FDD	3	20	20	+1.0/-1.7	18.3	21
2A-48A	LTE	FDD-TDD	3	20	20	+1.0/-1.7	18.3	21
48A-66A	LTE	TDD-FDD	3	20	20	+1.0/-1.7	18.3	21
48C	LTE	TDD	3	20	20	+1.0/-1.7	18.3	21

SAR Definition [5]

Specific Absorption Rate is defined as the time derivative (rate) of the incremental energy (dW) absorbed by (dissipated in) an incremental mass (dm) contained in a volume element (dV) of a given density (ρ).

$$SAR = \frac{d}{dt} \left(\frac{dW}{dm} \right) = \frac{d}{dt} \left(\frac{dW}{\rho dV} \right)$$

SAR is expressed in units of watts per kilogram (W/kg). SAR can be related to the electric field at a point by

$$SAR = \frac{\sigma |E|^2}{\rho}$$

where:

σ = conductivity of the tissue (S/m)

ρ = mass density of the tissue (kg/m³)

E = rms electric field strength (V/m)

2. SAR Measurement Setup

Robotic System

These measurements are performed using the DASY52 automated dosimetric assessment system. The DASY52 is made by Schmid & Partner Engineering AG (SPEAG) in Zurich, Switzerland and consists of high precision robotics system (Staubli), robot controller, Intel Core2 computer, near-field probe, probe alignment sensor, and the generic twin phantom containing the brain equivalent material. The robot is a six-axis industrial robot performing precise movements to position the probe to the location (points) of maximum electromagnetic field (EMF) (see Fig. 2.1).

System Hardware

A cell controller system contains the power supply, robot controller teach pendant (Joystick), and a remote control used to drive the robot motors. The PC consists of the HP Intel Core2 computer with Windows XP system and SAR Measurement Software DASY52, A/D interface card, monitor, mouse, and keyboard. The Staubli Robot is connected to the cell controller to allow software manipulation of the robot. A data acquisition electronic (DAE) circuit that performs the signal amplification, signal multiplexing, AD-conversion, offset measurements, mechanical surface detection, collision detection, etc. is connected to the Electro-optical coupler (EOC). The EOC performs the conversion from the optical into digital electric signal of the DAE and transfers data to the PC plug-in card.

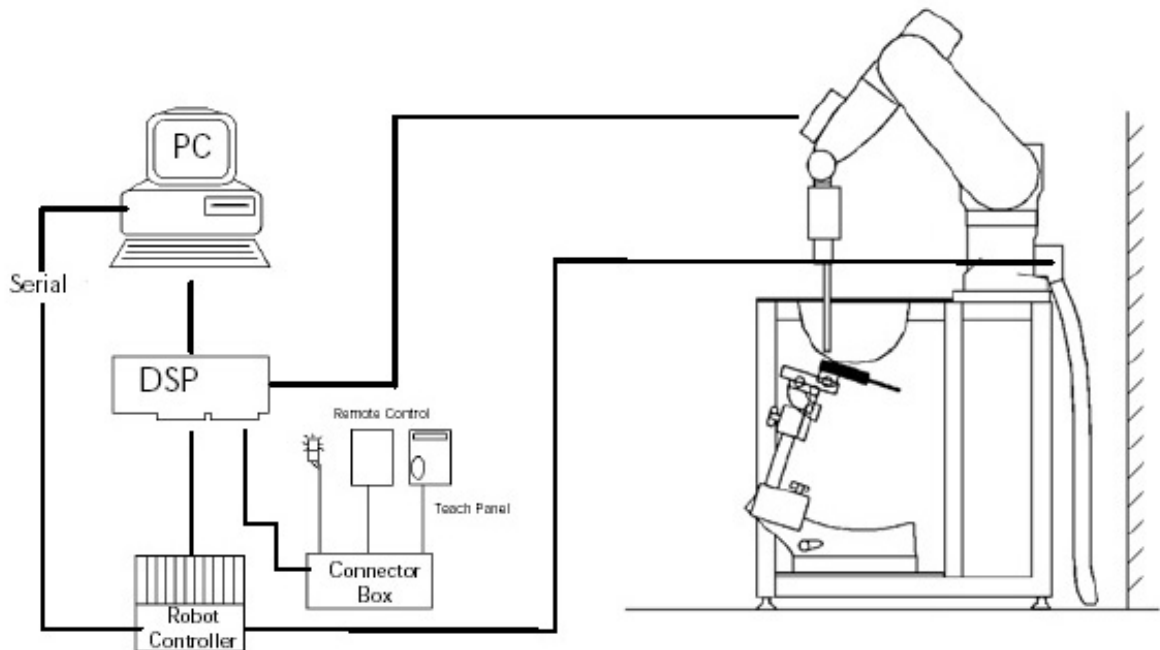

Figure 2.1 SAR Measurement System Setup

System Electronics

The DAE4 consists of a highly sensitive electrometer-grade preamplifier with auto-zeroing, a channel and gain-switching multiplexer, a fast 16 bit AD-converter and a command decoder and control logic unit. Transmission to the PC-card is accomplished through an optical downlink for data and status information and an optical uplink for commands and clock lines. The mechanical probe mounting device includes two different sensor systems for frontal and sidewise probe contacts. They are also used for mechanical surface detection and probe collision detection. The robot uses its own controller with a built in VME-bus computer. The system is described in detail in.

Probe Measurement System

The SAR measurements were conducted with the dosimetric probe EX3DV4, designed in the classical triangular configuration (see Fig. 2.2) and optimized for dosimetric evaluation. The probe is constructed using the thick film technique; with printed resistive lines on ceramic substrates. The probe is equipped with an optical multi fiber line ending at the front of the probe tip. (see Fig. 2.3) It is connected to the EOC box on the robot arm and provides an automatic detection of the phantom surface. Half of the fibers are connected to a pulsed infrared transmitter, the other half to a synchronized receiver. As the probe approaches the surface, the reflection from the surface produces a coupling from the transmitting to the receiving fibers. This reflection increases first during the approach, reaches maximum and then decreases. If the probe is flatly touching the surface, the coupling is zero. The distance of the coupling maximum to the surface is independent of the surface reflectivity and largely independent of the surface to probe angle. The DASY52 software reads the reflection during a software approach and looks for the maximum using a 2nd order fitting. The approach is stopped at reaching the maximum.



DAE System

Probe Specifications

Calibration: In air from 10 MHz to 6.0 GHz
In brain and muscle simulating tissue at Frequencies of 450 MHz, 835 MHz, 1750 MHz, 1900 MHz, 2450 MHz, 2600 MHz, 3500 MHz, 5200 MHz, 5300 MHz, 5600 MHz, 5800 MHz

Frequency: 10 MHz to 6 GHz

Linearity: ±0.2dB (30 MHz to 6 GHz)

Dynamic: 10 mW/kg to 100 W/kg

Range: Linearity: ±0.2dB

Dimensions: Overall length: 330 mm

Tip length: 20 mm

Body diameter: 12 mm

Tip diameter: 2.5 mm

Distance from probe tip to sensor center: 1 mm

Application: SAR Dosimetry Testing
Compliance tests of wireless device

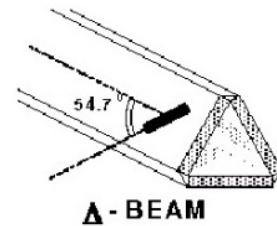

Figure 2.2 Triangular Probe Configurations



Figure 2.3 Probe Thick-Film Technique

Probe Calibration Process

Dosimetric Assessment Procedure

Each probe is calibrated according to a dosimetric assessment procedure described in with accuracy better than +/- 10%. The spherical isotropy was evaluated with the procedure described in and found to be better than +/-0.25dB. The sensitivity parameters (Norm X, Norm Y, Norm Z), the diode compression parameter (DCP) and the conversion factor (Conv F) of the probe is tested.

Free Space Assessment

The free space E-field from amplified probe outputs is determined in a test chamber. This is performed in a TEM cell for frequencies below 1 GHz, and in a waveguide above 1GHz for free space. For the free space calibration, the probe is placed in the volumetric center of the cavity at the proper orientation with the field. The probe is then rotated 360 degrees until the three channels show the maximum reading. The power density readings equates to 1 mW/cm².

Temperature Assessment *

E-field temperature correlation calibration is performed in a flat phantom filled with the appropriate simulated brain tissue. The measured free space E-field in the medium, correlates to temperature rise in a dielectric medium. For temperature correlation calibration a RF transparent thermistor based temperature probe is used in conjunction with the E-field probe

$$SAR = C \frac{\Delta T}{\Delta t}$$

$$SAR = \frac{|E|^2 \cdot \sigma}{\rho}$$

where:

where:

Δt = exposure time (30 seconds),

σ = simulated tissue conductivity,

C = heat capacity of tissue (brain or muscle),

ρ = Tissue density (1.25 g/cm³ for brain tissue)

ΔT = temperature increase due to RF exposure.

SAR is proportional to $\Delta T / \Delta t$, the initial rate of tissue heating, before thermal diffusion takes place.

Now it's possible to quantify the electric field in the simulated tissue by equating the thermally derived SAR to the E- field;

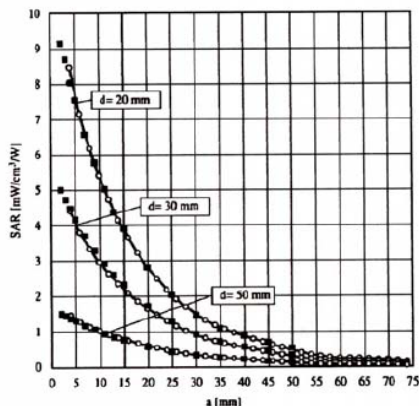

Figure 2.4 E-Field and Temperature Measurements at 900MHz

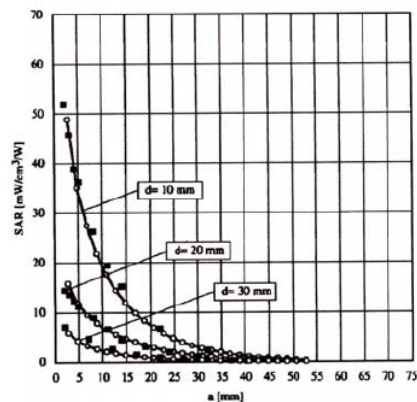

Figure 2.5 E-Field and Temperature Measurements at 1800MHz

Data Extrapolation

The DASY52 software automatically executes the following procedures to calculate the field units from the microvolt readings at the probe connector. The first step of the evaluation is a linearization of the filtered input signal to account for the compression characteristics of the detector diode. The compensation depends on the input signal, the diode type and the DC-transmission factor from the diode to the evaluation electronics. If the exciting field is pulsed, the crest factor of the signal must be known to correctly compensate for peak power. The formula for each channel can be given like below;

$$V_i = U_i + U_i^2 \cdot \frac{cf}{dcp_i}$$

with V_i = compensated signal of channel i (i=x,y,z)
 U_i = input signal of channel i (i=x,y,z)
 cf = crest factor of exciting field (DASY parameter)
 dcp_i = diode compression point (DASY parameter)

From the compensated input signals the primary field data for each channel can be evaluated:

E-field probes:

$$E_i = \sqrt{\frac{V_i}{Norm_i \cdot ConvF}}$$

with V_i = compensated signal of channel i (i = x,y,z)
 $Norm_i$ = sensor sensitivity of channel i (i = x,y,z)
 $\mu V/(V/m)^2$ for E-field probes
 $ConvF$ = sensitivity of enhancement in solution
 E_i = electric field strength of channel i in V/m

The RSS value of the field components gives the total field strength (Hermetian magnitude):

$$E_{tot} = \sqrt{E_x^2 + E_y^2 + E_z^2}$$

The primary field data are used to calculate the derived field units.

$$SAR = E_{tot}^2 \cdot \frac{\sigma}{\rho \cdot 1000}$$

with SAR = local specific absorption rate in W/g
 E_{tot} = total field strength in V/m
 σ = conductivity in [mho/m] or [Siemens/m]
 ρ = equivalent tissue density in g/cm^3

The power flow density is calculated assuming the excitation field to be a free space field.

$$P_{free} = \frac{E_{tot}^2}{3770}$$

with P_{pwe} = equivalent power density of a plane wave in W/cm^2
 E_{tot} = total electric field strength in V/m

Scanning procedure

- The DASY installation includes predefined files with recommended procedures for measurements and system check. They are read-only document files and destined as fully defined but unmeasured masks. All test positions (head or body-worn) are tested with the same configuration of test steps differing only in the grid definition for the different test positions.
- The „reference“ and „drift“ measurements are located at the beginning and end of the batch process. They measure the field drift at one single point in the liquid over the complete procedure. The indicated drift is mainly the variation of the DUT’s output power and should vary max. +/- 5 %.
- The highest integrated SAR value is the main concern in compliance test applications. These values can mostly be found at the inner surface of the phantom and cannot be measured directly due to the sensor offset in the probe. To extrapolate the surface values, the measurement distances to the surface must be known accurately. A distance error of 0.5mm could produce SAR errors of 6% at 1800 MHz. Using predefined locations for measurements is not accurate enough. Any shift of the phantom (e.g., slight deformations after filling it with liquid) would produce high uncertainties. For an automatic and accurate detection of the phantom surface, the DASY5 system uses the mechanical surface detection. The detection is always at touch, but the probe will move backward from the surface the indicated distance before starting the measurement.
- The „area scan“ measures the SAR above the DUT or verification dipole on a parallel plane to the surface. It is used to locate the approximate location of the peak SAR with 2D spline interpolation. The robot performs a stepped movement along one grid axis while the local electrical field strength is measured by the probe. The probe is touching the surface of the SAM during acquisition of measurement values. The scan uses different grid spacings for different frequency measurements. Standard grid spacing for head measurements in frequency ranges \leq 2GHz is 15 mm in x - and y-dimension. For higher frequencies a finer resolution is needed, thus for the grid spacing is reduced according the following table:

Area scan grid spacing for different frequency ranges	
Frequency range	Grid spacing
\leq 2 GHz	\leq 15 mm
2 – 4 GHz	\leq 12 mm
4 – 6 GHz	\leq 10 mm

Grid spacing and orientation have no influence on the SAR result. For special applications where the standard scan method does not find the peak SAR within the grid, e.g. mobile phones with flip cover, the grid can be adapted in orientation. Results of this coarse scan are shown in annex B.

- A „zoom scan“ measures the field in a volume around the 2D peak SAR value acquired in the previous „coarse“ scan. It uses a fine meshed grid where the robot moves the probe in steps along all the 3 axis (x,y and z-axis) starting at the bottom of the Phantom. The grid spacing for the cube measurement is varied according to the measured frequency range, the dimensions are given in the following table:

Zoom scan grid spacing and volume for different frequency ranges			
Frequency range	Grid spacing for x, y axis	Grid spacing for z axis	Minimum zoom scan volume
\leq 2 GHz	\leq 8 mm	\leq 5 mm	\geq 30 mm
2 – 3 GHz	\leq 5 mm	\leq 5 mm	\geq 28 mm
3 – 4 GHz	\leq 5 mm	\leq 4 mm	\geq 28 mm
4 – 5 GHz	\leq 4 mm	\leq 3 mm	\geq 25 mm
5 – 6 GHz	\leq 4 mm	\leq 2 mm	\geq 22 mm

DASY is also able to perform repeated zoom scans if more than 1 peak is found during area scan. In this document, the evaluated peak 1g and 10g averaged SAR values are shown in the 2D-graphics in annex B. Test

results relevant for the specified standard (see section 3) are shown in table form in section 7.

Spatial Peak SAR Evaluation

The spatial peak SAR - value for 1 and 10 g is evaluated after the Cube measurements have been done. The basis of the evaluation are the SAR values measured at the points of the fine cube grid consisting of all points in the three directions x, y and z. The algorithm that finds the maximal averaged volume is separated into three different stages.

- The data between the dipole center of the probe and the surface of the phantom are extrapolated. This data cannot be measured since the center of the dipole is 1 to 2.7 mm away from the tip of the probe and the distance between the surface and the lowest measuring point is about 1 mm (see probe calibration sheet). The extrapolated data from a cube measurement can be visualized by selecting 'Graph Evaluated'.
- The maximum interpolated value is searched with a straight-forward algorithm. Around this maximum the SAR - values averaged over the spatial volumes (1g or 10 g) are computed using the 3d-spline interpolation algorithm. If the volume cannot be evaluated (i.e., if a part of the grid was cut off by the boundary of the measurement area) the evaluation will be started on the corners of the bottom plane of the cube.
- All neighbouring volumes are evaluated until no neighbouring volume with a higher average value is found.

Extrapolation

The extrapolation is based on a least square algorithm [W. Gander, Computermathematik, p.168-180]. Through the points in the first 3 cm along the z-axis, polynomials of order four are calculated. These polynomials are then used to evaluate the points between the surface and the probe tip. The points, calculated from the surface, have a distance of 1 mm from each other.

Interpolation

The interpolation of the points is done with a 3d-Spline. The 3d-Spline is composed of three one-dimensional splines with the "Not a knot"-condition [W. Gander, Computermathematik, p.141-150] (x, y and z -direction) [Numerical Recipes in C, Second Edition, p.123ff].

Volume Averaging

At First the size of the cube is calculated. Then the volume is integrated with the trapezoidal algorithm. 8000 points (20x20x20) are interpolated to calculate the average.

Advanced Extrapolation

DASY uses the advanced extrapolation option which is able to compensate boundary effects on E-field probes.

SAM PHANTOM

The SAM Twin Phantom V4.0 is constructed of a fiberglass shell integrated in a wooden table. The shape of the shell is based on data from an anatomical study designed to determine the maximum exposure in at least 90% of all users. It enables the dosimetric evaluation of left and right hand phone usage as well as body mounted usage at the flat phantom region. A cover prevents the evaporation of the liquid. Reference markings on the Phantom allow the complete setup of all predefined phantom positions and measurement grids by manually teaching three points in the robot. (see Fig. 2.6)

Phantom Specification

Phantom: SAM Twin Phantom (V4.0)
Shell Material: Vivac Composite
Thickness: 2.0 ± 0.2 mm



Figure 2.6 SAM Twin Phantom

Device Holder for Transmitters

In combination with the SAM Twin Phantom V4.0 the Mounting Device (see Fig. 2.7), enables the rotation of the mounted transmitter in spherical coordinates whereby the rotation point is the ear opening. The devices can be easily, accurately, and repeatedly be positioned according to the FCC, CENELEC, IEC and IEEE specifications. The device holder can be locked at different phantom locations (left head, right head, flat phantom).



Figure 2.7 Mounting Device

Note: A simulating human hand is not used due to the complex anatomical and geometrical structure of the hand that may produce infinite number of configurations. To produce the worst-case condition (the hand absorbs antenna output power), the hand is omitted during the tests.

3. Probe and Dipole Calibration

See Appendix D and E.

4. Phantom & Simulating Tissue Specifications

Head & Body Simulating Mixture Characterization

The head and body mixtures consist of the material based on the table listed below. The mixture is calibrated to obtain proper dielectric constant (permittivity) and conductivity of the desired tissue. Body tissue parameters that have not been specified in IEEE1528 – 2013 are derived from the issue dielectric parameters computed from the 4-Cole-Cole equations.

Table 4.1 Typical Composition of Ingredients for Tissue

Ingredients		Simulating Tissue					
		750 MHz Body	835 MHz Body	1900 MHz Body	2450 MHz Body	1750 MHz Body	3-5 GHz Body
Mixing Percentage							
Water			52.50	69.91	73.20		
Sugar		Proprietary Purchased From Speag	45.00	0.00	0.00	Proprietary Purchased From Speag	Proprietary Purchased From Speag
Salt			1.40	0.13	0.10		
HEC			1.00	0.00	0.00		
Bactericide			0.10	0.00	0.00		
DGBE			0.00	29.96	26.70		
Dielectric Constant	Target	55.50	55.20	53.30	52.70	53.4	Various
Conductivity (S/m)	Target	0.96	0.97	1.52	1.95	1.49	Various

5. ANSI/IEEE C95.1 – 1992 RF Exposure Limits [2]

Uncontrolled Environment

Uncontrolled Environments are defined as locations where there is the exposure of individuals who have no knowledge or control of their exposure. The general population/uncontrolled exposure limits are applicable to situations in which the general public may be exposed or in which persons who are exposed as a consequence of their employment may not be made fully aware of the potential for exposure or cannot exercise control over their exposure. Members of the general public would come under this category when exposure is not employment-related; for example, in the case of a wireless transmitter that exposes persons in its vicinity.

Controlled Environment

Controlled Environments are defined as locations where there is exposure that may be incurred by persons who are aware of the potential for exposure, (i.e. as a result of employment or occupation). In general, occupational/controlled exposure limits are applicable to situations in which persons are exposed as a consequence of their employment, who have been made fully aware of the potential for exposure and can exercise control over their exposure. This exposure category is also applicable when the exposure is of a transient nature due to incidental passage through a location where the exposure levels may be higher than the general population/uncontrolled limits, but the exposed person is fully aware of the potential for exposure and can exercise control over his or her exposure by leaving the area or by some other appropriate means.

Table 5.1 Human Exposure Limits

	UNCONTROLLED ENVIRONMENT General Population (W/kg) or (mW/g)	CONTROLLED ENVIROMENT Professional Population (W/kg) or (mW/g)
SPATIAL PEAK SAR ¹ Head	1.60	8.00
SPATIAL AVERAGE SAR ² Whole Body	0.08	0.40
SPATIAL PEAK SAR ³ Hands, Feet, Ankles, Wrists	4.00	20.00

¹ The Spatial Peak value of the SAR averaged over any 1 gram of tissue (defined as a tissue volume in the shape of a cube) and over the appropriate averaging time.

² The Spatial Average value of the SAR averaged over the whole body.

³ The Spatial Peak value of the SAR averaged over any 10 grams of tissue (defined as a tissue volume in the shape of a cube) and over the appropriate averaging time.

6. Measurement Uncertainty

Measurement uncertainty table is not required per KDB 865664 D01 v01r04 section 2.8.2 page 12. SAR measurement uncertainty analysis is required in the SAR report only when the highest measured SAR in a frequency band is ≥ 1.5 W/kg for 1-g SAR. The equivalent ratio (1.5/1.6) should be applied to extremity and occupational exposure conditions. The highest reported value is less than 1.5 W/kg. Therefore, the measurement uncertainty table is not required.

7. System Validation

Tissue Verification

Table 7.1 Measured Tissue Parameters

		750 MHz Body		835 MHz Body		835 MHz Body	
Date(s)		Feb. 19, 2019		Feb. 18, 2019		Mar. 5, 2019	
Liquid Temperature (°C)	20.0	Target	Measured	Target	Measured	Target	Measured
Dielectric Constant: ϵ		55.53	54.43	55.20	54.57	55.20	54.37
Conductivity: σ		0.96	1.02	0.97	0.99	0.97	0.98
		1750 MHz Body		1750 MHz Body		1900 MHz Body	
Date(s)		Feb. 21, 2019		Mar. 6, 2019		Feb. 11, 2019	
Liquid Temperature (°C)	20.0	Target	Measured	Target	Measured	Target	Measured
Dielectric Constant: ϵ		53.43	52.66	53.43	52.68	53.30	52.97
Conductivity: σ		1.49	1.54	1.49	1.56	1.52	1.58
		1900 MHz Body		3500 MHz Body		3700 MHz Body	
Date(s)		Mar. 4, 2019		Mar. 9, 2019		Mar. 13, 2019	
Liquid Temperature (°C)	20.0	Target	Measured	Target	Measured	Target	Measured
Dielectric Constant: ϵ		53.30	53.17	51.32	51.11	51.05	50.86
Conductivity: σ		1.52	1.54	3.32	3.34	3.55	3.54
		2450 MHz Body		5250 MHz Body		5750 MHz Body	
Date(s)		Mar. 13, 2019		Mar. 11, 2019		Mar. 11, 2019	
Liquid Temperature (°C)	20.0	Target	Measured	Target	Measured	Target	Measured
Dielectric Constant: ϵ		52.70	52.58	49.01	48.88	48.20	48.14
Conductivity: σ		1.95	2.00	5.30	5.40	6.00	5.99
		750 MHz Body		835 MHz Body		1750 MHz Body	
Date(s)		May 7, 2019		May 7, 2019		May 7, 2019	
Liquid Temperature (°C)	20.0	Target	Measured	Target	Measured	Target	Measured
Dielectric Constant: ϵ		55.53	55.57	55.20	55.91	53.43	53.32
Conductivity: σ		0.96	0.99	0.97	0.99	1.49	1.52
		1900 MHz Body		3500 MHz Body		3700 MHz Body	
Date(s)		May 7, 2019		May 7, 2019		May 7, 2019	
Liquid Temperature (°C)	20.0	Target	Measured	Target	Measured	Target	Measured
Dielectric Constant: ϵ		53.30	52.07	51.32	50.93	51.05	50.68
Conductivity: σ		1.52	1.47	3.32	3.33	3.55	3.53

See Appendix A for data printout.

Test System Verification

Prior to assessment, the system is verified to the $\pm 10\%$ of the specifications at the test frequency by using the system kit. Power is normalized to 1 watt. (Graphic Plots Attached)

Table 7.2 System Dipole Validation Target & Measured

	Test Frequency	Targeted SAR _{1g} (W/kg)	Measure SAR _{1g} (W/kg)	Tissue Used for Verification	Deviation (%)	Plot Number
19-Feb-2019	750 MHz	8.55	8.61	Body	+ 0.70	1
18-Feb-2019	835 MHz	9.57	9.61	Body	+ 0.42	2
05-Mar-2019	835 MHz	9.57	9.63	Body	+ 0.63	3
21-Feb-2019	1750 MHz	36.50	36.90	Body	+ 1.10	4
06-Mar-2019	1750 MHz	36.50	36.50	Body	+ 0.00	5
11-Feb-2019	1900 MHz	39.90	40.10	Body	+ 0.50	6
04-Mar-2019	1900 MHz	39.90	40.20	Body	+ 0.75	7
09-Mar-2019	3500 MHz	65.10	65.50	Body	+ 0.61	8
09-Mar-2019	3700 MHz	65.50	65.90	Body	+ 0.61	9
13-Mar-2019	2450 MHz	51.00	51.20	Body	+ 0.39	10
11-Mar-2019	5200 MHz	76.80	76.30	Body	- 0.65	11
11-Mar-2019	5800 MHz	76.20	75.90	Body	- 0.39	12
07-May-2019	750 MHz	8.55	8.65	Body	+ 1.17	13
07-May-2019	835 MHz	9.57	9.53	Body	- 0.42	14
07-May-2019	1750 MHz	36.50	36.80	Body	+ 0.82	15
07-May-2019	1900 MHz	39.90	39.80	Body	- 0.25	16
07-May-2019	3500 MHz	65.10	65.70	Body	+ 0.92	17
07-May-2019	3700 MHz	65.50	66.20	Body	+ 1.07	18

See Appendix A for data plots.

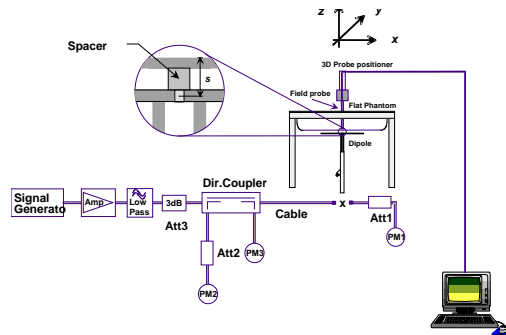

Figure 7.1 Dipole Validation Test Setup

8. LTE Document Checklist

- 1) Identify the operating frequency range of each LTE transmission band used by the device

LTE Operating Band	Uplink (transmit)	Downlink (Receive)	Duplex mode (FDD/TDD)
	Low - high	Low - high	
2	1850-1910	1930-1990	FDD
4	1710-1755	2110-2155	FDD
5	824-849	869-894	FDD
13	777-787	746-756	FDD
48	3550-3700	3550-3700	TDD
66	1710-1780	2110-2200	FDD

- 2) Identify the channel bandwidths used in each frequency band; 1.4, 3, 5, 10, 15, 20 MHz etc

LTE Band Class	Bandwidth (MHz)	Frequency or Freq. Band (MHz)
2	1.4, 3, 5, 10, 15, 20	1850-1910 MHz
4	1.4, 3, 5, 10, 15, 20	1710-1755 MHz
5	1.4, 3, 5, 10	824-849 MHz
13	5, 10	777-787 MHz
48	5, 10, 15, 20	3550-3700 MHz
66	1.4, 3, 5, 10, 15, 20	1710-1780 MHz

- 3) Identify the high, middle and low (H, M, L) channel numbers and frequencies in each LTE frequency band

LTE Band Class	Bandwidth (MHz)	Frequency (MHz)/Channel #					
		Low		Mid		High	
2	1.4	1850.7	18607	1880.0	18900	1909.3	19193
2	3	1851.5	18615	1880.0	18900	1908.5	19185
2	5	1852.5	18625	1880.0	18900	1907.5	19175
2	10	1855.0	18650	1880.0	18900	1905.0	19150
2	15	1857.5	18675	1880.0	18900	1902.5	19125
2	20	1860.0	18700	1880.0	18900	1900.0	19100
4	1.4	1710.7	19957	1732.5	20175	1754.3	20393
4	3	1711.5	19965	1732.5	20175	1753.5	20385
4	5	1712.5	19975	1732.5	20175	1752.5	20375
4	10	1715.0	20000	1732.5	20175	1750.0	20350
4	15	1717.5	20025	1732.5	20175	1747.5	20325
4	20	1720.0	20050	1732.5	20175	1745.0	20300
5	1.4	824.7	20407	836.5	20525	848.3	20643
5	3	825.5	20415	836.5	20525	847.5	20635
5	5	826.5	20425	836.5	20525	846.5	20625
5	10	829.0	20450	836.5	20525	844.0	20600
13	5	779.5	23205	782.0	23230	784.5	23225
13	10	-----	-----	782.0	23230	-----	-----
48	5	3552.5	55265	3526.0	55990	3697.5	56715
48	10	3555.0	55290	3526.0	55990	3695.0	56690
48	15	3557.5	55315	3526.0	55990	3692.5	56665
48	20	3560.0	55340	3526.0	55990	3690.0	56640
66	5	1712.5	131997	1755.0	132422	1777.4	132646
66	10	1716.1	132033	1755.0	132422	1774.9	132621
66	15	1717.5	132047	1755.0	132422	1772.4	132596
66	20	1720.0	132072	1755.0	132422	1769.9	132571

- 4) Specify the UE category and uplink modulations used:
- UE Category: 3
 - Uplink modulations: QPSK and 16QAM

- 5) Include descriptions of the LTE transmitter and antenna implementation; and also identify whether it is a standalone transmitter operating independently of other wireless transmitters in the device or sharing hardware components and/or antenna(s) with other transmitters etc

The device has 14 antennas:

- #0 WWAN Antenna (Transmit and Receive) Antenna (B2, B4, B5, B13, B66)
- #1 WWAN Antenna (Receive Only)
- #2 WWAN Antenna (Receive Only)
- #3 WWAN Antenna (Receive Only)
- #4 WWAN Antenna (B48 Only)
- #5 WWAN Antenna (Receive Only)
- #6 WWAN Antenna (Not Used)
- #7 WWAN Antenna (Not Used)
- #8 WLAN0 Antenna (Transmit and Receive)
- #9 WLAN1 Antenna (Transmit and Receive)
- #10 5G Antenna 0
- #11 5G Antenna 1
- #12 5G Antenna 2
- #13 5G Antenna 3

Transmission relationship

- All transmission (TX) is limited to the mmW, WWAN and WLAN antennas only
- The device is unable to transmit WCDMA/HSPA and LTE simultaneously.
- Rx is simultaneous
- Simultaneous Tx with the WWAN and WLAN is active.

- 6) Identify the LTE voice/data requirements in each operating mode and exposure condition with respect to head and body test configurations, antenna locations, handset flip-cover or slide positions, antenna diversity conditions etc

The device is a data only hotspot device. Data mode was tested in each operating mode and exposure condition in the body configuration. See test setup photos to see all configurations tested.

- 7) Identify if Maximum Power Reduction (MPR) is optional or mandatory, i.e. built-in by design:
- a) Only mandatory MPR may be considered during SAR testing, when the maximum output power is permanently limited by the MPR implemented within the UE; and only for the applicable RB (resource block) configurations specified in LTE standards

MPR is mandatory, built-in by design on all production units. It was enabled during testing.

Modulation	Channel Bandwidth/transmission Bandwidth Configuration (RB)						MPR (dB)
	1.4 MHz	3.0 MHz	5 MHz	10 MHz	15 MHz	20 MHz	
QPSK	> 5	> 4	> 8	> 12	> 16	> 18	≤ 1
16QAM	≤ 5	≤ 4	≤ 8	≤ 12	≤ 16	≤ 18	≤ 1
16QAM	> 5	> 4	> 8	> 12	> 16	> 18	≤ 2

- b) A-MPR (additional MPR) must be disabled
- c) A-MPR was disabled during testing.

- 8) Include the maximum average conducted output power measured on the required test channels for each channel bandwidth and UL modulation used in each frequency band:

The maximum average conducted output power measured for the testing is listed on pages 48-64 of this report. The below table shows the factory set point with the allowable tolerance.

Band	Technology	Class	3GPP Nominal Power dBm	Calibrated Nominal Power dBm	Tolerance dBm	Lower Tolerance dBm	Upper Tolerance dBm
Band 2 – 1900 MHz	LTE	3	23.0	22.0	+0.5/-1.7	20.3	22.5
Band 4 – 1750 MHz	LTE	3	23.0	22.0	+1.0/-1.7	20.3	23.0
Band 5 – 835 MHz	LTE	3	23.0	23.0	+1.0/-1.7	21.3	24.0
Band 13 – 750 MHz	LTE	3	23.0	23.0	+1.0/-1.7	21.3	24.0
Band 66 – 1750 MHz	LTE	3	23.0	22.0	+1.0/-1.7	20.3	23.0
Band 48 – 3600 MHz	LTE-TDD	3	23.0	23.0	+1.0/-1.7	21.3	24.0

- 9) Identify all other U.S. wireless operating modes (3G, Wi-Fi, WiMax, Bluetooth etc), device/exposure configurations (head and body, antenna and handset flip-cover or slide positions, antenna diversity conditions etc.) and frequency bands used for these modes

Other wireless modes:

Band	Technology	Class	3GPP Nominal Power dBm	Calibrated Nominal Power dBm	Tolerance dBm	Lower Tolerance dBm	Upper Tolerance dBm
Band 2 – 1900 MHz	WCDMA/HSPA	3	23.0	23.0	+1.0/-2.0	21.0	24.0
Band 4 – 1750 MHz	WCDMA/HSPA	3	23.0	23.0	+1.0/-2.0	21.0	24.0
Band 5 – 850 MHz	WCDMA/HSPA	3	23.0	23.0	+1.0/-2.0	21.0	24.0
WLAN – 2.4 GHz	802.11b	N/A	N/A	12.0	±2.0	10.0	14.0
WLAN – 2.4 GHz	802.11g/n	N/A	N/A	12.0	±2.0	10.0	14.0
WLAN – 5.2 GHz	802.11an/ac	N/A	N/A	12.0	±2.0	10.0	14.0
WLAN – 5.8 GHz	802.11an/ac	N/A	N/A	12.0	±2.0	10.0	14.0

- 10) Include the maximum average conducted output power measured for the other wireless modes and frequency bands.

The maximum average conducted output power measured for the testing is listed on pages 27-39 of this report. The table in item 9 shows the factory set point with the allowable tolerance.

- 11) Identify the simultaneous transmission conditions for the voice and data configurations supported by all wireless modes, device configurations and frequency bands, for the head and body exposure conditions and device operating configurations (handset flip or cover positions, antenna diversity conditions etc.)

The device is unable to transmit WCDMA and LTE simultaneously.

The device is able to transmit WWAN and WLAN simultaneously.

TX Modes	WCDMA	LTE	802.11 b/g/n
1	ON	OFF	ON
2	OFF	ON	ON

- 12) When power reduction is applied to certain wireless modes to satisfy SAR compliance for simultaneous transmission conditions, other equipment certification or operating requirements, include the maximum average conducted output power measured in each power reduction mode applicable to the simultaneous voice/data transmission configurations for such wireless configurations and frequency bands; and also include details of the power reduction implementation and measurement setup

Power reduction is not required to satisfy SAR compliance.

- 13) Include descriptions of the test equipment, test software, built-in test firmware etc. required to support testing the device when power reduction is applied to one or more transmitters/antennas for simultaneous voice/data transmission

Power reduction is not required to satisfy SAR compliance.

- 14) When appropriate, include a SAR test plan proposal with respect to the above

Power reduction is not required to satisfy SAR compliance.

- 15) If applicable, include preliminary SAR test data and/or supporting information in laboratory testing inquiries to address specific issues and concerns or for requesting further test reduction considerations appropriate for the device; for example, simultaneous transmission configurations.

Not applicable.

9. SAR Test Data Summary

See Measurement Result Data Pages

See Appendix B for SAR Test Data Plots.
See Appendix C for SAR Test Setup Photos.

Procedures Used To Establish Test Signal

The device was either placed into simulated transmit mode using the manufacturer's test codes or the actual transmission is activated through a base station simulator or similar equipment. See data pages for actual procedure used in measurement.

Device Test Condition

In order to verify that the device was tested at full power, conducted output power measurements were performed before and after each SAR measurement to confirm the output power unless otherwise noted. If a conducted power deviation of more than 5% occurred, the test was repeated. The power drift of each test is measured at the start of the test and again at the end of the test. The drift percentage is calculated by the formula $((\text{end}/\text{start})-1)*100$ and rounded to three decimal places. The drift percentage is calculated into the resultant SAR value on the data sheet for each test.

The testing was conducted on all edges closest to each antenna. Side A, Side B, Side C, Side D and Side E testing was conducted for the WWAN antenna for WCDMA and LTE Bands B2, B4, B5, B13, B14, and B66. The Side F was not tested for WCDMA and these LTE bands as the antenna was more than 2.5 cm from this side. Side A, Side C, Side D and Side E testing was conducted for the WWAN antenna for LTE Band B48. Side B and Side F were not tested as the WWAN antenna for B48 was more than 2.5 cm from these sides. The Side A, Side C, and Side F was tested for both WLAN antennas. Side B was tested for WLAN Tx0 antenna and Side D was tested for WLAN Tx1 antenna. Side D and Side E were not tested for Tx0 as the antenna was more than 2.5 cm from these sides. Side B and Side E were not tested for Tx1 as the antenna was more than 2.5 cm from these sides. All further test reductions are shown on page 46 for WCDMA bands, page 40-45 for WLAN and pages 65-80 for LTE bands. All testing was conducted per KDB 941225 D06. See the photo in Appendix C for a pictorial of the setups, labeling of the sides tested and antenna locations.

The WCDMA testing was conducted using 12.2 kbps RMC configured in Test Loop Mode 1. The HSPA testing was conducted with HS-DPCCH, E-DPCCH and E-DPDCH all enabled and a 12.2 kbps RMC. FRC was configured according to HS-DPCCH Sub-Test 1 using H-set 1 and QPSK.

Figure 10.1
SAR Location Diagram of Modem Testing

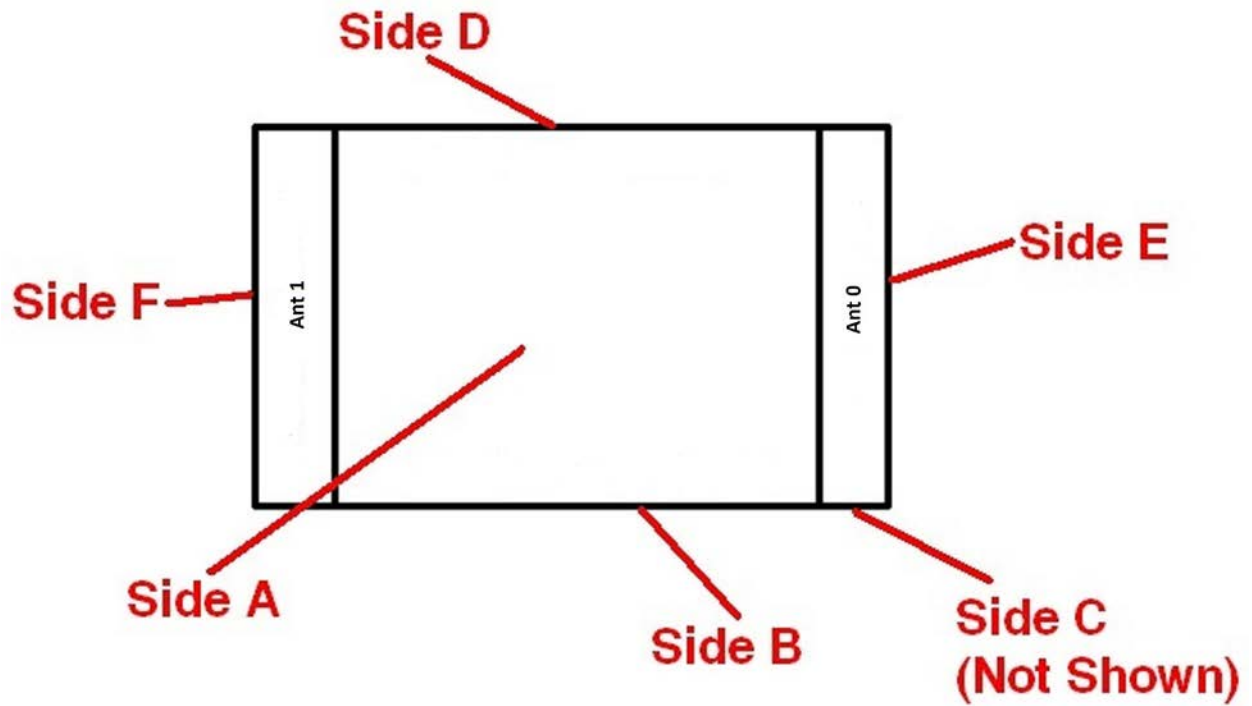

10. FCC 3G Measurement Procedures

Power measurements were performed using a base station simulator under average power.

10.1 Procedures Used to Establish RF Signal for SAR

The device was placed into a simulated call using a base station simulator in a screen room. Such test signals offer a consistent means for testing SAR and recommended for evaluating SAR. The SAR measurement software calculates a reference point at the start and end of the test to check for power drifts. If conducted power deviations of more than 5% occurred, the tests were repeated.

10.2 SAR Measurement Conditions for WCDMA/HSDPA/HSUPA

Configure the call box 8960 to support all WCDMA tests in respect to the 3GPP 34.121 (listed in Table below). Measure the power at Ch4132, 4182 and 4233 for US cell; Ch9262, 9400 and 9538 for US PCS band.

For Rel99

- Set a Test Mode 1 loop back with a 12.2kbps Reference Measurement Channel (RMC).
- Set and send continuously Up power control commands to the device
- Measure the power at the device antenna connector using the power meter with average detector.

For HSDPA Rel 6

- Establish a Test Mode 1 look back with both 1 12.2kbps RMC channel and a H-Set1 Fixed Reference Channel (FRC). With the 8960 this is accomplished by setting the signal Channel Coding to "Fixed Reference Channel" and configuring for HSET-1 QKSP.
- Set beta values and HSDPA settings for HSDPA Subtest1 according to Table below.
- Send continuously Up power control commands to the device
- Measure the power at the device antenna connector using the power meter with modulated average detector.
- Repeat the measurement for the HSDPA Subtest2, 3 and 4 as given in Table below.

For HSUPA Rel 6

- Use UL RMC 12.2kbps and FRC H-Set1 QPSK, Test Mode 1 loop back. With the 8960 this is accomplished by setting the signal Channel Coding to "E-DCH Test Channel" and configuring the equipment category to Cat5_10ms.
- Set the Absolute Grant for HSUPA Subtest1 according to Table below.
- Set the device power to be at least 5dB lower than the Maximum output power
- Send power control bits to give one TPC_cmd = +1 command to the device. If device doesn't send any E-DPCH data with decreased E-TFCl within 500ms, then repeat this process until the decreased E-TFCl is reported.
- Confirm that the E-TFCl transmitted by the device is equal to the target E-TFCl in Table below. If the E-TFCl transmitted by the device is not equal to the target E-TFCl, then send power control bits to give one TPC_cmd = -1 command to the UE. If UE sends any E-DPCH data with decreased E-TFCl within 500 ms, send new power control bits to give one TPC_cmd = -1 command to the UE. Then confirm that the E-TFCl transmitted by the UE is equal to the target E-TFCl in Table below.
- Measure the power using the power meter with modulated average detector.
- Repeat the measurement for the HSUPA Subtest2, 3, 4 and 5 as given in Table below.

3GPP Release Version	Mode	Cellular Band [dBm]			Sub-Test (See Table Below)	MPR
		4132	4183	4233		
99	WCDMA	23.70	24.00	23.70	-	-
6	HSDPA	23.36	23.07	23.09	1	0
6		23.32	23.09	23.05	2	0
6		22.99	22.92	22.89	3	0.5
6		22.94	22.99	22.90	4	0.5
6	HSUPA	23.40	23.10	23.13	1	0
6		21.45	21.49	21.46	2	2
6		22.47	22.48	22.49	3	1
6		21.46	21.41	21.44	4	2
6		23.32	23.04	23.07	5	0

PP Release Version	Mode	AWS Band [dBm]			Sub-Test (See Table Below)	MPR
		1312	1413	1513		
99	WCDMA	23.83	23.91	23.97	-	-
6	HSDPA	23.79	23.82	23.76	1	0
6		23.81	23.75	23.79	2	0
6		23.36	23.34	23.36	3	0.5
6		23.41	23.31	23.39	4	0.5
6	HSUPA	23.84	23.82	23.75	1	0
6		21.97	22.01	21.89	2	2
6		22.94	23.05	22.94	3	1
6		21.99	21.95	22.03	4	2
6		23.82	23.80	23.71	5	0

3GPP Release Version	Mode	PCS Band [dBm]			Sub-Test (See Table Below)	MPR
		9262	9400	9538		
99	WCDMA	23.60	23.70	23.40	-	-
6	HSDPA	23.02	23.00	23.31	1	0
6		23.01	22.99	23.28	2	0
6		22.56	22.52	22.66	3	0.5
6		22.41	22.31	22.52	4	0.5
6	HSUPA	23.00	22.98	23.21	1	0
6		21.07	21.01	21.12	2	2
6		22.06	22.05	22.23	3	1
6		20.99	20.95	22.03	4	2
6		22.89	22.91	23.05	5	0

Sub-Test Setup for Release 6 HSDPA

Sub-Test	β_c	β_d	B_c/β_d	β_{hs}
1	2/15	15/15	2/15	4/15
2	12/15	15/15	15/15	24/15
3	15/15	8/15	15/8	30/15
4	15/15	4/15	15/4	30/15

$\Delta_{ack}, \Delta_{nack}$ and $\Delta_{cqi} = 8$

Sub-Test Setup for Release 6 HSUPA

Sub-Test	β_c	β_d	B_c/β_d	β_{hs}	B_{ec}	B_{ed}	MPR	AG Index	E-TFCI
1	11/15	15/15	11/15	22/15	209/225	1039/225	0.0	20	75
2	6/15	15/15	6/15	12/15	12/15	94/75	2.0	12	67
3	15/15	9/15	15/9	30/15	30/15	47/15	1.0	15	92
4	2/15	15/15	2/15	4/15	2/15	56/15	2.0	17	71
5	15/15	15/15	15/15	30/15	24/15	134/15	0.0	21	81

$\Delta_{ack}, \Delta_{nack}$ and $\Delta_{cqi} = 8$

Band	Mode	Bandwidth (MHz)	Channel	Frequency (MHz)	Data Rate	Antenna	Avg Power (dBm)	Tune-up Pwr (dBm)				
2450 MHz	802.11b	20	1	2412	1 Mbps	Tx0	13.6	14.00				
			6	2437			13.4	14.00				
			11	2462			13.5	14.00				
			1	2412		Tx1	13.5	14.00				
			6	2437			13.3	14.00				
			11	2462			13.6	14.00				
			1	2412	2 Mbps	Tx0	13.6	14.00				
			6	2437			13.4	14.00				
			11	2462			13.6	14.00				
			1	2412		Tx1	13.7	14.00				
			6	2437			13.5	14.00				
			11	2462			13.6	14.00				
			1	2412	5.5 Mbps	Tx0	13.5	14.00				
			6	2437			13.2	14.00				
			11	2462			13.5	14.00				
			1	2412		Tx1	13.4	14.00				
			6	2437			13.1	14.00				
			11	2462			13.4	14.00				
			1	2412	11 Mbps	Tx0	13.6	14.00				
			6	2437			13.5	14.00				
			11	2462			13.6	14.00				
			1	2412		Tx1	13.8	14.00				
			6	2437			13.6	14.00				
			11	2462			13.7	14.00				
			802.11g	6 Mbps	20	1	2412	Tx0	13.7	14.00		
						6	2437		13.1	14.00		
						11	2462	Tx1	13.7	14.00		
						1	2412		13.7	14.00		
						6	2437	Tx0	13.2	14.00		
						11	2462		13.8	14.00		
	1	2412				Tx1	13.8	14.00				
	6	2437					13.1	14.00				
	11	2462				Tx0	13.7	14.00				
	1	2412					13.8	14.00				
	6	2437				Tx1	13.2	14.00				
	11	2462					13.8	14.00				
	9 Mbps	20				20	1	2412	Tx0	13.8	14.00	
							6	2437		13.2	14.00	
				11	2462		Tx1	13.8	14.00			
				1	2412			13.8	14.00			
				6	2437		Tx0	13.1	14.00			
				11	2462			13.7	14.00			
				1	2412		Tx1	13.7	14.00			
				6	2437			13.2	14.00			
				11	2462		Tx0	13.7	14.00			
				1	2412			13.2	14.00			
				6	2437		Tx1	13.7	14.00			
				11	2462			13.1	14.00			
				12 Mbps	20		20	1	2412	Tx0	13.7	14.00
								6	2437		13.2	14.00
	11	2462				Tx1		13.7	14.00			
	1	2412						13.1	14.00			
	6	2437				Tx0		13.6	14.00			
	11	2462						13.9	14.00			
	1	2412				Tx1		13.5	14.00			
	6	2437						13.9	14.00			
	11	2462				Tx0		13.8	14.00			
	1	2412						13.8	14.00			
	6	2437				Tx1		13.4	14.00			
	11	2462						13.7	14.00			
	18 Mbps	20				20		1	2412	Tx0	13.9	14.00
								6	2437		13.5	14.00
				11	2462		Tx1	13.9	14.00			
				1	2412			13.8	14.00			
				6	2437		Tx0	13.4	14.00			
				11	2462			13.7	14.00			
				1	2412		Tx1	13.7	14.00			
				6	2437			13.4	14.00			
				11	2462		Tx0	13.7	14.00			
				1	2412			13.9	14.00			
				6	2437		Tx1	13.5	14.00			
				11	2462			13.9	14.00			
				24 Mbps	20		20	1	2412	Tx0	13.9	14.00
								6	2437		13.5	14.00
	11	2462				Tx1		13.9	14.00			
	1	2412						13.8	14.00			
	6	2437				Tx0		13.6	14.00			
	11	2462						13.8	14.00			
	1	2412				Tx1		13.8	14.00			
	6	2437						13.6	14.00			
	11	2462				Tx0		13.8	14.00			
	1	2412						13.1	14.00			
	6	2437				Tx1		13.7	14.00			
	11	2462						13.5	14.00			
	36 Mbps	20				20		1	2412	Tx0	13.2	14.00
								6	2437		13.5	14.00
				11	2462		Tx1	13.2	14.00			
				1	2412			13.6	14.00			
				6	2437		Tx0	13.6	14.00			
				11	2462			13.4	14.00			
				1	2412		Tx1	13.7	14.00			
				6	2437			13.5	14.00			
				11	2462		Tx0	13.7	14.00			
				1	2412			13.6	14.00			
			6	2437	Tx1		13.5	14.00				
			11	2462			13.6	14.00				
			48 Mbps	20	20		1	2412	Tx0	13.8	14.00	
							6	2437		13.7	14.00	
	11	2462				Tx1	13.6	14.00				
	1	2412					13.8	14.00				
6	2437	Tx0				13.7	14.00					
11	2462					13.6	14.00					
1	2412	Tx1				13.8	14.00					
6	2437					13.7	14.00					
11	2462	Tx0				13.7	14.00					
1	2412					13.6	14.00					
6	2437	Tx1				13.7	14.00					
11	2462					13.5	14.00					
54 Mbps	20	20				1	2412	Tx0	13.7	14.00		
						6	2437		13.6	14.00		
			11	2462	Tx1	13.7	14.00					
			1	2412		13.7	14.00					
			6	2437	Tx0	13.5	14.00					
			11	2462		13.6	14.00					
			1	2412	Tx1	13.7	14.00					
			6	2437		13.5	14.00					
			11	2462	Tx0	13.6	14.00					
			1	2412		13.7	14.00					
			6	2437	Tx1	13.5	14.00					
			11	2462		13.6	14.00					

Band	Mode	Bandwidth (MHz)	Channel	Frequency (MHz)	Data Rate	Antenna	Avg Power (dBm)	Tune-up Pwr (dBm)		
2450 MHz	802.11n	20	1	2412	7.2 Mbps	Tx0	13.7	14.00		
			6	2437			13.5	14.00		
			11	2462			13.8	14.00		
			1	2412		Tx1	13.7	14.00		
			6	2437			13.6	14.00		
			11	2462			13.9	14.00		
			1	2412	14.4 Mbps	Tx0	13.7	14.00		
			6	2437			13.4	14.00		
			11	2462			13.6	14.00		
			1	2412		Tx1	13.6	14.00		
			6	2437			13.4	14.00		
			11	2462			13.4	14.00		
			1	2412	21.7 Mbps	Tx0	13.9	14.00		
			6	2437			13.5	14.00		
			11	2462			13.7	14.00		
			1	2412		Tx1	13.7	14.00		
			6	2437			13.3	14.00		
			11	2462			13.5	14.00		
			1	2412	28.9 Mbps	Tx0	13.7	14.00		
			6	2437			13.7	14.00		
			11	2462			13.9	14.00		
			1	2412		Tx1	13.7	14.00		
			6	2437			13.6	14.00		
			11	2462			13.8	14.00		
			1	2412	43.3 Mbps	Tx0	13.8	14.00		
			6	2437			13.4	14.00		
			11	2462			13.7	14.00		
			1	2412		Tx1	13.8	14.00		
			6	2437			13.4	14.00		
			11	2462			13.6	14.00		
			1	2412	57.8 Mbps	Tx0	13.8	14.00		
			6	2437			13.5	14.00		
			11	2462			13.7	14.00		
			1	2412		Tx1	13.8	14.00		
			6	2437			13.6	14.00		
			11	2462			13.7	14.00		
			1	2412	65.0 Mbps	Tx0	14.0	14.00		
			6	2437			13.8	14.00		
			11	2462			13.9	14.00		
			1	2412		Tx1	13.8	14.00		
			6	2437			13.7	14.00		
			11	2462			13.8	14.00		
			1	2412	72.2 Mbps	Tx0	13.5	14.00		
			6	2437			13.3	14.00		
			11	2462			13.6	14.00		
			1	2412		Tx1	13.7	14.00		
			6	2437			13.5	14.00		
			11	2462			13.8	14.00		
5.15-5.25 GHz	802.11a	20	36	5180	6 Mbps	Tx0	13.8	14.00		
			40	5200			13.7	14.00		
			44	5220			13.7	14.00		
			48	5240			13.5	14.00		
			36	5180			Tx1	13.7	14.00	
			40	5200				13.7	14.00	
			44	5220		13.6		14.00		
			48	5240		13.5		14.00		
			36	5180		9 Mbps		Tx0	13.5	14.00
			40	5200					13.6	14.00
			44	5220			13.6		14.00	
			48	5240			Tx1	13.6	14.00	
			36	5180	13.4			14.00		
			40	5200	13.5			14.00		
			44	5220	12 Mbps	Tx0	13.5	14.00		
			48	5240			13.4	14.00		
			36	5180			13.5	14.00		
			40	5200		Tx1	13.6	14.00		
			44	5220			13.5	14.00		
			48	5240			13.6	14.00		

Band	Mode	Bandwidth (MHz)	Channel	Frequency (MHz)	Data Rate	Antenna	Avg Power (dBm)	Tune-up Pwr (dBm)	
5.15-5.25 GHz	802.11a	20	36	5180	18 Mbps	Tx0	13.8	14.00	
			40	5200			13.8	14.00	
			44	5220			13.8	14.00	
			48	5240		13.7	14.00		
			36	5180		Tx1	13.8	14.00	
			40	5200			13.8	14.00	
			44	5220	13.7		14.00		
			48	5240	13.7	14.00			
			36	5180	24 Mbps	Tx0	13.8	14.00	
			40	5200			13.8	14.00	
			44	5220			13.8	14.00	
			48	5240		13.8	14.00		
			36	5180		Tx1	13.7	14.00	
			40	5200			13.7	14.00	
			44	5220	13.8		14.00		
			48	5240	13.7	14.00			
			36	5180	36 Mbps	Tx0	13.9	14.00	
			40	5200			13.8	14.00	
			44	5220			13.5	14.00	
			48	5240		13.9	14.00		
			36	5180		Tx1	13.6	14.00	
			40	5200			13.8	14.00	
			44	5220	13.8		14.00		
			48	5240	13.5	14.00			
	36	5180	48 Mbps	Tx0	13.6	14.00			
	40	5200			13.9	14.00			
	44	5220			13.5	14.00			
	48	5240		13.8	14.00				
	36	5180		Tx1	13.5	14.00			
	40	5200			13.7	14.00			
	44	5220	13.5		14.00				
	48	5240	13.6	14.00					
	36	5180	54 Mbps	Tx0	13.7	14.00			
	40	5200			13.6	14.00			
	44	5220			13.6	14.00			
	48	5240		13.8	14.00				
	36	5180		Tx1	13.7	14.00			
	40	5200			13.9	14.00			
	44	5220	13.4		14.00				
	48	5240	13.7	14.00					
	802.11n	20	7.2 Mbps	Tx0	36	5180	13.5	14.00	
					40	5200	13.5	14.00	
					44	5220	13.5	14.00	
				48	5240	13.7	14.00		
				36	5180	Tx1	13.6	14.00	
				40	5200		13.5	14.00	
				44	5220		13.5	14.00	
				48	5240	13.7	14.00		
				36	5180	14.4 Mbps	Tx0	13.5	14.00
				40	5200			13.6	14.00
				44	5220			13.5	14.00
				48	5240		13.5	14.00	
36			5180	Tx1	13.5		14.00		
40			5200		13.5		14.00		
44			5220		13.6	14.00			
48			5240	13.6	14.00				
36			5180	21.7 Mbps	Tx0	13.8	14.00		
40			5200			13.7	14.00		
44			5220			13.8	14.00		
48			5240		13.7	14.00			
36			5180		Tx1	13.6	14.00		
40			5200			13.5	14.00		
44			5220	13.7		14.00			
48			5240	13.6	14.00				
36			5180	28.9 Mbps	Tx0	13.8	14.00		
40			5200			13.7	14.00		
44			5220			13.6	14.00		
48			5240		13.9	14.00			
36	5180	Tx1	13.8		14.00				
40	5200		13.9		14.00				
44	5220		13.7	14.00					
48	5240	13.7	14.00						

Band	Mode	Bandwidth (MHz)	Channel	Frequency (MHz)	Data Rate	Antenna	Avg Power (dBm)	Tune-up Pwr (dBm)	
5.15-5.25 GHz	802.11n	20	36	5180	43.3 Mbps	Tx0	13.5	14.00	
			40	5200			13.7	14.00	
			44	5220			13.9	14.00	
			48	5240		Tx1	13.5	14.00	
			36	5180			13.8	14.00	
			40	5200			13.7	14.00	
			44	5220	13.6	14.00			
			48	5240	13.6	14.00			
			36	5180	57.8 Mbps	Tx0	13.3	14.00	
			40	5200			13.5	14.00	
			44	5220			13.7	14.00	
			48	5240		Tx1	13.8	14.00	
			36	5180			13.2	14.00	
			40	5200			13.6	14.00	
			44	5220	13.7	14.00			
			48	5240	13.5	14.00			
			36	5180	65.0 Mbps	Tx0	13.9	14.00	
			40	5200			13.8	14.00	
			44	5220			13.8	14.00	
			48	5240		Tx1	13.7	14.00	
			36	5180			13.7	14.00	
			40	5200			13.5	14.00	
			44	5220	13.6	14.00			
			48	5240	13.6	14.00			
	36	5180	72.2 Mbps	Tx0	13.9	14.00			
	40	5200			13.9	14.00			
	44	5220			13.7	14.00			
	48	5240		Tx1	13.9	14.00			
	36	5180			13.7	14.00			
	40	5200			13.6	14.00			
	44	5220	13.6	14.00					
	48	5240	13.9	14.00					
	802.11n	40	15 Mbps	Tx0	38	5190	13.8	14.00	
					46	5230	13.8	14.00	
					38	5190	Tx1	13.8	14.00
				46	5230	13.7		14.00	
				38	5190	13.6		14.00	
				46	5230	30 Mbps	Tx0	13.7	14.00
			38	5190	Tx1			13.7	14.00
			46	5230				13.8	14.00
			38	5190			Tx0	13.7	14.00
			46	5230	13.8			14.00	
			38	5190	Tx1			13.7	14.00
			46	5230		13.8	14.00		
			38	5190		45 Mbps	Tx0	13.7	14.00
			46	5230	13.8			14.00	
			38	5190	Tx1			13.7	14.00
			46	5230			13.9	14.00	
			38	5190			60 Mbps	Tx0	13.8
			46	5230	14.0				14.00
			38	5190	Tx1	13.8			14.00
			46	5230		13.7		14.00	
38			5190	90 Mbps		Tx0		13.7	14.00
46			5230		13.5			14.00	
38			5190		Tx1		13.8	14.00	
46			5230			13.8	14.00		
38			5190			120 Mbps	Tx0	14.0	14.00
46			5230		13.8			14.00	
38			5190	Tx1	13.8			14.00	
46			5230		13.8		14.00		
38			5190		135 Mbps		Tx0	13.8	14.00
46			5230	13.7				14.00	
38			5190	Tx1		13.9		14.00	
46			5230			13.7	14.00		
38			5190			150 Mbps	Tx0	13.7	14.00
46			5230	13.8				14.00	
38			5190	Tx1	14.0			14.00	
46			5230		13.6		14.00		
36	5180	7.2 Mbps	Tx0		13.5		14.00		
40	5200			13.6	14.00				
44	5220			13.7	14.00				
48	5240			13.6	14.00				
36	5180		Tx1	13.7	14.00				
40	5200			13.7	14.00				
44	5220			13.7	14.00				
48	5240			13.7	14.00				

Band	Mode	Bandwidth (MHz)	Channel	Frequency (MHz)	Data Rate	Antenna	Avg Power (dBm)	Tune-up Pwr (dBm)
5.15-5.25 GHz	802.11ac	20	36	5180	14.4 Mbps	Tx0	13.7	14.00
			40	5200			13.7	14.00
			44	5220			13.7	14.00
			48	5240			13.7	14.00
			36	5180			13.7	14.00
			40	5200		Tx1	13.8	14.00
			44	5220			13.6	14.00
			48	5240			13.7	14.00
			36	5180			13.7	14.00
			40	5200			13.9	14.00
			44	5220	21.7 Mbps	Tx0	13.8	14.00
			48	5240			13.8	14.00
			36	5180			13.9	14.00
			40	5200			13.9	14.00
			44	5220			13.9	14.00
			48	5240		14.0	14.00	
			36	5180		Tx1	13.9	14.00
			40	5200			13.9	14.00
			44	5220			13.9	14.00
			48	5240			14.0	14.00
			36	5180	13.9		14.00	
			40	5200	28.9 Mbps	Tx0	13.9	14.00
			44	5220			13.9	14.00
			48	5240			13.9	14.00
			36	5180			13.7	14.00
			40	5200			13.7	14.00
			44	5220		Tx1	13.8	14.00
			48	5240			13.8	14.00
			36	5180			13.7	14.00
			40	5200			13.7	14.00
			44	5220			13.8	14.00
			48	5240	43.3 Mbps	Tx0	13.9	14.00
			36	5180			13.7	14.00
			40	5200			13.8	14.00
			44	5220			13.7	14.00
			48	5240			13.7	14.00
			36	5180		Tx1	13.9	14.00
			40	5200			13.8	14.00
			44	5220			13.5	14.00
			48	5240			13.7	14.00
			36	5180			13.6	14.00
			40	5200	57.8 Mbps	Tx0	13.7	14.00
			44	5220			13.8	14.00
			48	5240			13.5	14.00
			36	5180			13.6	14.00
			40	5200			13.7	14.00
			44	5220		Tx1	13.8	14.00
			48	5240			13.8	14.00
			36	5180			13.8	14.00
			40	5200			13.7	14.00
			44	5220			13.8	14.00
			48	5240	65.0 Mbps	Tx0	13.8	14.00
			36	5180			13.9	14.00
			40	5200			13.8	14.00
			44	5220			13.8	14.00
			48	5240			13.8	14.00
			36	5180		Tx1	13.7	14.00
			40	5200			13.7	14.00
			44	5220			13.8	14.00
			48	5240			13.8	14.00
			36	5180			13.8	14.00
			40	5200	72.2 Mbps	Tx0	13.8	14.00
			44	5220			13.8	14.00
			48	5240			13.8	14.00
			36	5180			13.7	14.00
			40	5200			13.8	14.00
			44	5220		Tx1	13.8	14.00
			48	5240			13.8	14.00
			36	5180			13.7	14.00
			40	5200			13.8	14.00
	44	5220	13.8	14.00				
	48	5240	86.7 Mbps	Tx0	13.8	14.00		
	36	5180			13.7	14.00		
	40	5200			13.7	14.00		
	44	5220			13.7	14.00		
	48	5240			13.8	14.00		
	36	5180		Tx1	13.7	14.00		
	40	5200			13.6	14.00		
	44	5220			13.6	14.00		
	48	5240			13.8	14.00		
	36	5180			13.8	14.00		
	40	5200	15 Mbps	Tx0	13.7	14.00		
	46	5230			13.8	14.00		
	38	5190			Tx1	13.8	14.00	
	46	5230				13.8	14.00	
	38	5190				30 Mbps	13.8	14.00
	46	5230		13.9			14.00	
	38	5190		13.8			14.00	
	46	5230		Tx1	13.8		14.00	
	38	5190			13.8		14.00	
	46	5230			13.9	14.00		
	38	5190	45 Mbps		13.8	14.00		
	46	5230			13.8	14.00		
	38	5190		Tx0	13.8	14.00		
	46	5230			13.8	14.00		
	40	5200	Tx1	13.9	14.00			
	46	5230		13.9	14.00			

Band	Mode	Bandwidth (MHz)	Channel	Frequency (MHz)	Data Rate	Antenna	Avg Power (dBm)	Tune-up Pwr (dBm)	
5.15-5.25 GHz	802.11ac	40	38	5190	60 Mbps	Tx0	13.7	14.00	
			46	5230			13.8	14.00	
			38	5190		Tx1	13.9	14.00	
			46	5230			13.7	14.00	
			38	5190	90 Mbps	Tx0	13.7	14.00	
			46	5230			13.8	14.00	
			38	5190		Tx1	13.8	14.00	
			46	5230			13.8	14.00	
			38	5190	120 Mbps	Tx0	13.9	14.00	
			46	5230			13.9	14.00	
			38	5190		Tx1	13.8	14.00	
			46	5230			13.8	14.00	
			38	5190	135 Mbps	Tx0	13.9	14.00	
			46	5230			13.9	14.00	
			38	5190		Tx1	13.8	14.00	
			46	5230			13.7	14.00	
			38	5190	150 Mbps	Tx0	13.8	14.00	
			46	5230			13.9	14.00	
			38	5190		Tx1	13.9	14.00	
			46	5230			13.7	14.00	
	38	5190	180 Mbps	Tx0	13.8	14.00			
	46	5230			13.8	14.00			
	38	5190		Tx1	13.9	14.00			
	46	5230			13.9	14.00			
	38	5190	200 Mbps	Tx0	14.0	14.00			
	46	5230			14.0	14.00			
	38	5190		Tx1	13.8	14.00			
	46	5230			13.8	14.00			
	802.11ac	80	80	42	5210	32.5 Mbps	Tx0	13.9	14.00
				42	5210			Tx1	13.9
				42	5210	65.0 Mbps	Tx0	13.8	14.00
				42	5210			Tx1	14.0
				42	5210	97.5 Mbps	Tx0	13.8	14.00
				42	5210			Tx1	13.9
				42	5210	130.0 Mbps	Tx0	13.8	14.00
				42	5210			Tx1	13.7
				42	5210	195.0 Mbps	Tx0	13.7	14.00
				42	5210			Tx1	13.7
				42	5210	260.0 Mbps	Tx0	13.9	14.00
				42	5210			Tx1	13.9
42				5210	292.5 Mbps	Tx0	13.9	14.00	
42				5210			Tx1	13.7	14.00
42				5210	325.0 Mbps	Tx0	13.7	14.00	
42				5210			Tx1	13.7	14.00
42				5210	390.0 Mbps	Tx0	13.9	14.00	
42				5210			Tx1	14.0	14.00
42				5210	433.3 Mbps	Tx0	13.8	14.00	
42				5210			Tx1	13.9	14.00
5800 MHz	802.11a	20	149	5745	6 Mbps	Tx0	13.9	14.00	
			153	5765			13.9	14.00	
			157	5785			13.9	14.00	
			161	5805			13.7	14.00	
			165	5825			13.6	14.00	
			149	5745		Tx1	13.7	14.00	
			153	5765			13.7	14.00	
			157	5785			13.7	14.00	
			161	5805			13.8	14.00	
			165	5825			13.9	14.00	
			149	5745	9 Mbps	Tx0	13.8	14.00	
			153	5765			13.7	14.00	
			157	5785			13.9	14.00	
			161	5805			13.9	14.00	
			165	5825			13.7	14.00	
			149	5745		Tx1	13.7	14.00	
			153	5765			13.7	14.00	
			157	5785			13.8	14.00	
			161	5805			13.6	14.00	
			165	5825			13.6	14.00	

Band	Mode	Bandwidth (MHz)	Channel	Frequency (MHz)	Data Rate	Antenna	Avg Power (dBm)	Tune-up Pwr (dBm)	
5800 MHz	801.11a	20	149	5745	12 Mbps	Tx0	13.8	14.00	
			153	5765			13.7	14.00	
			157	5785			13.7	14.00	
			161	5805			13.8	14.00	
			165	5825			13.7	14.00	
			149	5745			Tx1	13.8	14.00
			153	5765		13.9		14.00	
			157	5785		13.7		14.00	
			161	5805		13.8		14.00	
			165	5825		13.8		14.00	
			149	5745		18 Mbps		13.6	14.00
			153	5765			Tx0	13.8	14.00
			157	5785	13.8			14.00	
			161	5805	13.8			14.00	
			165	5825	13.7			14.00	
			149	5745	Tx1			13.8	14.00
			153	5765				13.7	14.00
			157	5785			13.6	14.00	
			161	5805			13.8	14.00	
			165	5825			13.8	14.00	
			149	5745			24 Mbps	13.9	14.00
			153	5765	Tx0			13.7	14.00
			157	5785		13.8		14.00	
			161	5805		13.9		14.00	
			165	5825		13.7		14.00	
			149	5745		Tx1		13.8	14.00
			153	5765				13.8	14.00
			157	5785	13.9			14.00	
			161	5805	13.7			14.00	
			165	5825	13.6			14.00	
			149	5745	36 Mbps			13.7	14.00
			153	5765		Tx0		13.8	14.00
			157	5785			13.7	14.00	
			161	5805			13.8	14.00	
			165	5825			13.8	14.00	
			149	5745			Tx1	13.8	14.00
			153	5765				13.9	14.00
			157	5785		13.8		14.00	
			161	5805		13.8		14.00	
			165	5825		13.7		14.00	
			149	5745		48 Mbps		13.7	14.00
			153	5765			Tx0	13.6	14.00
			157	5785	13.8			14.00	
			161	5805	13.9			14.00	
			165	5825	13.8			14.00	
			149	5745	Tx1			13.7	14.00
			153	5765				13.7	14.00
			157	5785			13.7	14.00	
	161	5805	13.8	14.00					
	165	5825	13.8	14.00					
	149	5745	54 Mbps	13.7			14.00		
	153	5765		Tx0	13.8		14.00		
	157	5785			13.7	14.00			
	161	5805			13.7	14.00			
	165	5825			13.7	14.00			
	149	5745			Tx1	13.7	14.00		
	153	5765				13.8	14.00		
	157	5785		13.8		14.00			
	161	5805		13.8		14.00			
	165	5825		13.6		14.00			
149	5745	7.2 Mbps		13.9		14.00			
153	5765			Tx0	13.8	14.00			
157	5785		13.9		14.00				
161	5805		13.8		14.00				
165	5825		13.7		14.00				
149	5745		Tx1		13.8	14.00			
153	5765				13.7	14.00			
157	5785			13.8	14.00				
161	5805			13.8	14.00				
165	5825			13.8	14.00				
149	5745				13.8	14.00			

13.9

Band	Mode	Bandwidth (MHz)	Channel	Frequency (MHz)	Data Rate	Antenna	Avg Power (dBm)	Tune-up Pwr (dBm)
5800 MHz	802.11n	20	149	5745	14.4 Mbps	Tx0	13.7	14.00
			153	5765			13.9	14.00
			157	5785			13.8	14.00
			161	5805			13.9	14.00
			165	5825			13.7	14.00
			149	5745		Tx1	13.6	14.00
			153	5765			13.6	14.00
			157	5785			13.8	14.00
			161	5805			13.7	14.00
			165	5825			13.8	14.00
			149	5745	21.7 Mbps	Tx0	13.9	14.00
			153	5765			13.7	14.00
			157	5785			13.7	14.00
			161	5805			13.7	14.00
			165	5825			13.7	14.00
			149	5745		Tx1	13.8	14.00
			153	5765			13.8	14.00
			157	5785			13.6	14.00
			161	5805			13.8	14.00
			165	5825			13.6	14.00
			149	5745	28.9 Mbps	Tx0	13.8	14.00
			153	5765			13.6	14.00
			157	5785			13.8	14.00
			161	5805			13.8	14.00
			165	5825			13.9	14.00
			149	5745		Tx1	13.9	14.00
			153	5765			13.7	14.00
			157	5785			13.8	14.00
			161	5805			13.6	14.00
			165	5825			13.6	14.00
			149	5745	43.3 Mbps	Tx0	13.7	14.00
			153	5765			13.8	14.00
			157	5785			13.7	14.00
			161	5805			13.9	14.00
			165	5825			13.6	14.00
			149	5745		Tx1	13.7	14.00
			153	5765			13.8	14.00
			157	5785			13.7	14.00
			161	5805			13.8	14.00
			165	5825			13.8	14.00
			149	5745	57.8 Mbps	Tx0	13.9	14.00
			153	5765			13.8	14.00
			157	5785			13.9	14.00
			161	5805			13.6	14.00
			165	5825			13.7	14.00
			149	5745		Tx1	13.8	14.00
			153	5765			13.7	14.00
			157	5785			13.8	14.00
161	5805	13.7	14.00					
165	5825	13.6	14.00					
149	5745	65.0 Mbps	Tx0	13.7	14.00			
153	5765			13.8	14.00			
157	5785			13.7	14.00			
161	5805			13.7	14.00			
165	5825			13.7	14.00			
149	5745		Tx1	13.7	14.00			
153	5765			13.6	14.00			
157	5785			13.9	14.00			
161	5805			13.7	14.00			
165	5825			13.7	14.00			
149	5745	72.2 Mbps	Tx0	13.9	14.00			
153	5765			13.9	14.00			
157	5785			13.7	14.00			
161	5805			13.7	14.00			
165	5825			13.8	14.00			
149	5745		Tx1	13.9	14.00			
153	5765			13.6	14.00			
157	5785			13.8	14.00			
161	5805			13.6	14.00			
165	5825			13.7	14.00			

13.7

Band	Mode	Bandwidth (MHz)	Channel	Frequency (MHz)	Data Rate	Antenna	Avg Power (dBm)	Tune-up Pwr (dBm)
5800 MHz	802.11n	40	151	5755	15 Mbps	Tx0	13.8	14.00
			159	5795			13.9	14.00
			151	5755		Tx1	13.9	14.00
			159	5795			13.7	14.00
			151	5755	30 Mbps	Tx0	13.7	14.00
			159	5795			13.7	14.00
			151	5755		Tx1	13.8	14.00
			159	5795			13.9	14.00
			151	5755	45 Mbps	Tx0	13.9	14.00
			159	5795			13.8	14.00
			151	5755		Tx1	13.7	14.00
			159	5795			13.7	14.00
			151	5755	60 Mbps	Tx0	13.6	14.00
			159	5795			13.7	14.00
			151	5755		Tx1	13.9	14.00
			159	5795			13.8	14.00
			151	5755	90 Mbps	Tx0	13.8	14.00
			159	5795			13.7	14.00
			151	5755		Tx1	13.9	14.00
			159	5795			13.9	14.00
			151	5755	120 Mbps	Tx0	13.8	14.00
			159	5795			13.6	14.00
			151	5755		Tx1	13.8	14.00
			159	5795			13.8	14.00
			151	5755	135 Mbps	Tx0	13.8	14.00
			159	5795			13.7	14.00
			151	5755		Tx1	13.8	14.00
			159	5795			13.7	14.00
			151	5755	150 Mbps	Tx0	13.7	14.00
			159	5795			13.8	14.00
			151	5755		Tx1	13.9	14.00
			159	5795			13.7	14.00
			149	5745	7.2 Mbps	Tx0	13.9	14.00
			153	5765			13.7	14.00
			157	5785			13.8	14.00
			161	5805			13.9	14.00
	165	5825	Tx1	13.9		14.00		
	149	5745		13.8		14.00		
	153	5765		13.6		14.00		
	157	5785		13.7		14.00		
	161	5805	Tx0	13.6		14.00		
	165	5825		13.7		14.00		
	149	5745		13.7		14.00		
	153	5765		13.8		14.00		
	157	5785	Tx1	13.9	14.00			
	161	5805		13.7	14.00			
	165	5825		13.9	14.00			
	149	5745		13.7	14.00			
153	5765	14.4 Mbps	Tx0	13.7	14.00			
157	5785			13.8	14.00			
161	5805			13.7	14.00			
165	5825			13.9	14.00			
149	5745		Tx1	13.7	14.00			
153	5765			13.8	14.00			
157	5785			13.8	14.00			
161	5805			13.6	14.00			
165	5825		Tx0	13.7	14.00			
149	5745			13.7	14.00			
153	5765			13.6	14.00			
157	5785			13.7	14.00			
161	5805	Tx1	13.9	14.00				
165	5825		13.8	14.00				
149	5745		13.7	14.00				
153	5765		13.8	14.00				
157	5785	21.7 Mbps	Tx0	13.7	14.00			
161	5805			13.8	14.00			
165	5825			13.7	14.00			
149	5745			13.8	14.00			
153	5765		Tx1	13.7	14.00			
157	5785			13.8	14.00			
161	5805			13.7	14.00			
165	5825			13.8	14.00			

Band	Mode	Bandwidth (MHz)	Channel	Frequency (MHz)	Data Rate	Antenna	Avg Power (dBm)	Tune-up Pwr (dBm)
5800 MHz	802.11ac	20	149	5745	28.9 Mbps	Tx0	13.8	14.00
			153	5765			13.9	14.00
			157	5785			13.8	14.00
			161	5805			13.8	14.00
			165	5825			13.6	14.00
			149	5745			13.7	14.00
			153	5765		Tx1	13.7	14.00
			157	5785			13.7	14.00
			161	5805			13.8	14.00
			165	5825			13.8	14.00
			149	5745			13.8	14.00
			153	5765			13.7	14.00
			157	5785	43.3 Mbps	13.7	14.00	
			161	5805		13.8	14.00	
			165	5825		13.8	14.00	
			149	5745		13.9	14.00	
			153	5765		Tx1	13.7	14.00
			157	5785			13.7	14.00
			161	5805			13.7	14.00
			165	5825			13.8	14.00
			149	5745			13.8	14.00
			153	5765			13.7	14.00
			157	5785		57.8 Mbps	13.8	14.00
			161	5805			13.8	14.00
			165	5825	13.6		14.00	
			149	5745	13.7		14.00	
			153	5765	Tx1		13.8	14.00
			157	5785			13.6	14.00
			161	5805			13.9	14.00
			165	5825			13.9	14.00
			149	5745			13.7	14.00
			153	5765			13.8	14.00
			157	5785	65.0 Mbps		13.9	14.00
			161	5805			13.6	14.00
			165	5825		13.9	14.00	
			149	5745		13.8	14.00	
			153	5765		Tx1	13.8	14.00
			157	5785			13.9	14.00
			161	5805			13.9	14.00
			165	5825			13.8	14.00
			149	5745			13.8	14.00
			153	5765			13.7	14.00
			157	5785		72.2 Mbps	13.6	14.00
			161	5805			13.8	14.00
			165	5825	13.7		14.00	
			149	5745	13.8		14.00	
			153	5765	Tx1		13.9	14.00
			157	5785			13.7	14.00
	161	5805	13.8	14.00				
	165	5825	13.7	14.00				
	149	5745	13.8	14.00				
	153	5765	13.9	14.00				
	157	5785	86.7 Mbps	13.6	14.00			
	161	5805		13.8	14.00			
	165	5825		13.7	14.00			
	149	5745		13.9	14.00			
	153	5765		Tx1	13.6	14.00		
	157	5785			13.9	14.00		
	161	5805			13.7	14.00		
	165	5825			13.6	14.00		
149	5745	13.7			14.00			
153	5765	13.8			14.00			
157	5785	15 Mbps		13.7	14.00			
161	5805			13.8	14.00			
165	5825		13.6	14.00				
149	5745		13.8	14.00				
153	5765		30 Mbps	13.7	14.00			
157	5785			13.6	14.00			
161	5805	13.6		14.00				
165	5825	13.9		14.00				
149	5745	13.9		14.00				
153	5765	13.9		14.00				

Band	Mode	Bandwidth (MHz)	Channel	Frequency (MHz)	Data Rate	Antenna	Avg Power (dBm)	Tune-up Pwr (dBm)	
5800 MHz	802.11ac	40	151	5755	45 Mbps	Tx0	13.7	14.00	
			159	5795		Tx0	13.8	14.00	
			151	5755		Tx1	13.7	14.00	
			159	5795		Tx1	13.6	14.00	
			151	5755	60 Mbps	Tx0	13.7	14.00	
			159	5795		Tx0	13.8	14.00	
			151	5755		Tx1	13.8	14.00	
			159	5795		Tx1	13.8	14.00	
			151	5755	90 Mbps	Tx0	13.8	14.00	
			159	5795		Tx0	13.6	14.00	
			151	5755		Tx1	13.8	14.00	
			159	5795		Tx1	13.8	14.00	
			151	5755	120 Mbps	Tx0	13.8	14.00	
			159	5795		Tx0	13.8	14.00	
			151	5755		Tx1	13.6	14.00	
			159	5795		Tx1	13.9	14.00	
			151	5755	135 Mbps	Tx0	13.9	14.00	
			159	5795		Tx0	13.8	14.00	
			151	5755		Tx1	13.6	14.00	
			159	5795		Tx1	13.8	14.00	
			151	5755	150 Mbps	Tx0	13.8	14.00	
			159	5795		Tx0	13.7	14.00	
			151	5755		Tx1	13.8	14.00	
			159	5795		Tx1	13.8	14.00	
	151	5755	180 Mbps	Tx0	13.9	14.00			
	159	5795		Tx0	13.9	14.00			
	151	5755		Tx1	13.7	14.00			
	159	5795		Tx1	13.7	14.00			
	151	5755	200 Mbps	Tx0	13.8	14.00			
	159	5795		Tx0	13.9	14.00			
	151	5755		Tx1	13.7	14.00			
	159	5795		Tx1	13.8	14.00			
	802.11ac	80	80	155	5775	32.5 Mbps	Tx0	13.9	14.00
							Tx1	13.8	14.00
				155	5775	65.0 Mbps	Tx0	13.7	14.00
							Tx1	13.8	14.00
				155	5775	97.5 Mbps	Tx0	13.6	14.00
							Tx1	13.8	14.00
				155	5775	130.0 Mbps	Tx0	13.9	14.00
							Tx1	13.8	14.00
				155	5775	195.0 Mbps	Tx0	13.9	14.00
							Tx1	13.6	14.00
				155	5775	260.0 Mbps	Tx0	13.7	14.00
							Tx1	13.8	14.00
				155	5775	292.5 Mbps	Tx0	13.8	14.00
							Tx1	13.8	14.00
	155	5775	325.0 Mbps	Tx0	13.9	14.00			
				Tx1	13.8	14.00			
155	5775	390.0 Mbps	Tx0	13.8	14.00				
			Tx1	13.6	14.00				
155	5775	433.3 Mbps	Tx0	13.9	14.00				
			Tx1	13.8	14.00				

Figure 10.1 Test Reduction Table – WiFi 2.4 GHz Chain 0

Mode	Side	Required Channel	Tested/Reduced
802.11b	Side A	1 – 2412 MHz	Reduced ¹
		6 – 2437 MHz	Tested
		11 – 2462 MHz	Reduced ¹
	Side B	1 – 2412 MHz	Reduced ¹
		6 – 2437 MHz	Tested
		11 – 2462 MHz	Reduced ¹
	Side C	1 – 2412 MHz	Reduced ¹
		6 – 2437 MHz	Tested
		11 – 2462 MHz	Reduced ¹
	Side D	1 – 2412 MHz	Reduced ³
		6 – 2437 MHz	Reduced ³
		11 – 2462 MHz	Reduced ³
	Side E	1 – 2412 MHz	Reduced ³
		6 – 2437 MHz	Reduced ³
		11 – 2462 MHz	Reduced ³
	Side F	1 – 2412 MHz	Reduced ¹
		6 – 2437 MHz	Tested
		11 – 2462 MHz	Reduced ¹
802.11g	Side A	1 – 2412 MHz	Reduced ²
		6 – 2437 MHz	Reduced ²
		11 – 2462 MHz	Reduced ²
	Side B	1 – 2412 MHz	Reduced ²
		6 – 2437 MHz	Reduced ²
		11 – 2462 MHz	Reduced ²
	Side C	1 – 2412 MHz	Reduced ²
		6 – 2437 MHz	Reduced ²
		11 – 2462 MHz	Reduced ²
	Side D	1 – 2412 MHz	Reduced ²
		6 – 2437 MHz	Reduced ²
		11 – 2462 MHz	Reduced ²
	Side E	1 – 2412 MHz	Reduced ²
		6 – 2437 MHz	Reduced ²
		11 – 2462 MHz	Reduced ²
	Side F	1 – 2412 MHz	Reduced ²
		6 – 2437 MHz	Reduced ²
		11 – 2462 MHz	Reduced ²
802.11n	Side A	1 – 2412 MHz	Reduced ²
		6 – 2437 MHz	Reduced ²
		11 – 2462 MHz	Reduced ²
	Side B	1 – 2412 MHz	Reduced ²
		6 – 2437 MHz	Reduced ²
		11 – 2462 MHz	Reduced ²
	Side C	1 – 2412 MHz	Reduced ²
		6 – 2437 MHz	Reduced ²
		11 – 2462 MHz	Reduced ²
	Side D	1 – 2412 MHz	Reduced ²
		6 – 2437 MHz	Reduced ²
		11 – 2462 MHz	Reduced ²
	Side E	1 – 2412 MHz	Reduced ²
		6 – 2437 MHz	Reduced ²
		11 – 2462 MHz	Reduced ²
	Side F	1 – 2412 MHz	Reduced ²
		6 – 2437 MHz	Reduced ²
		11 – 2462 MHz	Reduced ²

Reduced¹ – When the reported SAR is ≤ 0.4 W/kg, SAR is not required for the remaining test configuration per KDB 248227 D01 v02r02 section 5.1.1 1) page 9.

Reduced² – When the highest reported SAR for DSSS is adjusted by the ratio of OFDM to DSSS specified maximum output power and the adjusted SAR is ≤ 1.2 W/kg, SAR is not required per KDB 248227 D01 v02r02 section 5.2.2 2) page 10.

Reduced³ – When the antenna is more than 25 mm from a side, the test can be reduced per KDB447498 D01 v06 section 4.3.1 1) page 11. See below for calculations.

Maximum power: 25.1 mW
 Closest Distance to Side D: 57 mm
 Closest Distance to Side E: 49 mm

The closest distance is from Side E. Therefore, if Side E is excluded then Side D would also be excluded.

$[(25.1 \text{ mW}) / (49 \text{ mm})]^2 \cdot 2.462 = 0.80$ which is equal to or less than 3.0.

Figure 10.2 Test Reduction Table – WiFi 2.4 GHz Chain 1

Mode	Side	Required Channel	Tested/Reduced
802.11b	Side A	1 – 2412 MHz	Reduced ¹
		6 – 2437 MHz	Tested
		11 – 2462 MHz	Reduced ¹
	Side B	1 – 2412 MHz	Reduced ³
		6 – 2437 MHz	Reduced ³
		11 – 2462 MHz	Reduced ³
	Side C	1 – 2412 MHz	Reduced ¹
		6 – 2437 MHz	Tested
		11 – 2462 MHz	Reduced ¹
	Side D	1 – 2412 MHz	Reduced ¹
		6 – 2437 MHz	Tested
		11 – 2462 MHz	Reduced ¹
	Side E	1 – 2412 MHz	Reduced ³
		6 – 2437 MHz	Reduced ³
		11 – 2462 MHz	Reduced ³
	Side F	1 – 2412 MHz	Reduced ¹
		6 – 2437 MHz	Tested
		11 – 2462 MHz	Reduced ¹
802.11g	Side A	1 – 2412 MHz	Reduced ²
		6 – 2437 MHz	Reduced ²
		11 – 2462 MHz	Reduced ²
	Side B	1 – 2412 MHz	Reduced ²
		6 – 2437 MHz	Reduced ²
		11 – 2462 MHz	Reduced ²
	Side C	1 – 2412 MHz	Reduced ²
		6 – 2437 MHz	Reduced ²
		11 – 2462 MHz	Reduced ²
	Side D	1 – 2412 MHz	Reduced ²
		6 – 2437 MHz	Reduced ²
		11 – 2462 MHz	Reduced ²
	Side E	1 – 2412 MHz	Reduced ²
		6 – 2437 MHz	Reduced ²
		11 – 2462 MHz	Reduced ²
	Side F	1 – 2412 MHz	Reduced ²
		6 – 2437 MHz	Reduced ²
		11 – 2462 MHz	Reduced ²
802.11n	Side A	1 – 2412 MHz	Reduced ²
		6 – 2437 MHz	Reduced ²
		11 – 2462 MHz	Reduced ²
	Side B	1 – 2412 MHz	Reduced ²
		6 – 2437 MHz	Reduced ²
		11 – 2462 MHz	Reduced ²
	Side C	1 – 2412 MHz	Reduced ²
		6 – 2437 MHz	Reduced ²
		11 – 2462 MHz	Reduced ²
	Side D	1 – 2412 MHz	Reduced ²
		6 – 2437 MHz	Reduced ²
		11 – 2462 MHz	Reduced ²
	Side E	1 – 2412 MHz	Reduced ²
		6 – 2437 MHz	Reduced ²
		11 – 2462 MHz	Reduced ²
	Side F	1 – 2412 MHz	Reduced ²
		6 – 2437 MHz	Reduced ²
		11 – 2462 MHz	Reduced ²

Reduced¹ – When the reported SAR is ≤ 0.4 W/kg, SAR is not required for the remaining test configuration per KDB 248227 D01 v02r02 section 5.1.1 1) page 9.

Reduced² – When the highest reported SAR for DSSS is adjusted by the ratio of OFDM to DSSS specified maximum output power and the adjusted SAR is ≤ 1.2 W/kg, SAR is not required per KDB 248227 D01 v02r02 section 5.2.2 2) page 10.

Reduced³ – When the antenna is more than 25 mm from a side, the test can be reduced per KDB447498 D01 v06 section 4.3.1 1) page 11. See below for calculations.

Maximum power: 25.1 mW
 Closest Distance to Side B: 57 mm
 Closest Distance to Side E: 49 mm

The closest distance is from Side E. Therefore, if Side E is excluded then Side B would also be excluded.

$[(25.1 \text{ mW}) / (49 \text{ mm})]^2 \cdot 2.462 = 0.80$ which is equal to or less than 3.0.

Figure 10.3 Test Reduction Table – WiFi 5.1 GHz Chain 0

Mode	Side	Required Channel	Tested/Reduced
802.11a 5150 MHz	Side A	36 – 5180 MHz	Reduced ¹
		40 – 5200 MHz	Reduced ¹
		44 – 5220 MHz	Tested
		48 – 5240 MHz	Reduced ¹
	Side B	36 – 5180 MHz	Reduced ¹
		40 – 5200 MHz	Reduced ¹
		44 – 5220 MHz	Tested
		48 – 5240 MHz	Reduced ¹
	Side C	36 – 5180 MHz	Reduced ¹
		40 – 5200 MHz	Reduced ¹
		44 – 5220 MHz	Tested
		48 – 5240 MHz	Reduced ¹
	Side D	36 – 5180 MHz	Reduced ²
		40 – 5200 MHz	Reduced ²
		44 – 5220 MHz	Reduced ²
		48 – 5240 MHz	Reduced ²
	Side E	36 – 5180 MHz	Reduced ²
		40 – 5200 MHz	Reduced ²
		44 – 5220 MHz	Reduced ²
		48 – 5240 MHz	Reduced ²
	Side F	36 – 5180 MHz	Reduced ¹
		40 – 5200 MHz	Reduced ¹
		44 – 5220 MHz	Tested
		48 – 5240 MHz	Reduced ¹
802.11n 5150 MHz	Side A	36 – 5180 MHz	Reduced ¹
		40 – 5200 MHz	Reduced ¹
		44 – 5220 MHz	Reduced ¹
		48 – 5240 MHz	Reduced ¹
	Side B	36 – 5180 MHz	Reduced ¹
		40 – 5200 MHz	Reduced ¹
		44 – 5220 MHz	Reduced ¹
		48 – 5240 MHz	Reduced ¹
	Side C	36 – 5180 MHz	Reduced ¹
		40 – 5200 MHz	Reduced ¹
		44 – 5220 MHz	Reduced ¹
		48 – 5240 MHz	Reduced ¹
	Side D	36 – 5180 MHz	Reduced ²
		40 – 5200 MHz	Reduced ²
		44 – 5220 MHz	Reduced ²
		48 – 5240 MHz	Reduced ²
	Side E	36 – 5180 MHz	Reduced ²
		40 – 5200 MHz	Reduced ²
		44 – 5220 MHz	Reduced ²
		48 – 5240 MHz	Reduced ²
	Side F	36 – 5180 MHz	Reduced ¹
		40 – 5200 MHz	Reduced ¹
		44 – 5220 MHz	Reduced ¹
		48 – 5240 MHz	Reduced ¹

Reduced¹ – When the reported SAR is ≤ 0.4 W/kg, SAR is not required for the remaining test configuration per KDB 248227 D01 v02r02 section 5.1.1 1) page 9.

Reduced² – When the antenna is more than 25 mm from a side, the test can be reduced per KDB447498 D01 v06 section 4.3.1 1) page 11. See below for calculations.

Reduced³ – When the reported SAR is >0.4 W/kg, test the next highest configuration until the SAR value is ≤ 0.8 W/kg per KDB 248227 D01 v02r02 section 5.1.1 2) page 9.

Maximum power: 25.1 mW
 Closest Distance to Side D: 57 mm
 Closest Distance to Side E: 49 mm

The closest distance is from Side E. Therefore, if Side E is excluded then Side D would also be excluded.

$$[(25.1 \text{ mW}) / (49 \text{ mm})]^2 / 5.24 = 1.17 \text{ which is equal to or less than } 3.0.$$

Figure 10.4 Test Reduction Table – WiFi 5.1 GHz Chain 1

Mode	Side	Required Channel	Tested/Reduced
802.11a 5150 MHz	Side A	36 – 5180 MHz	Reduced ¹
		40 – 5200 MHz	Reduced ¹
		44 – 5220 MHz	Tested
		48 – 5240 MHz	Reduced ¹
	Side B	36 – 5180 MHz	Reduced ²
		40 – 5200 MHz	Reduced ²
		44 – 5220 MHz	Reduced ²
		48 – 5240 MHz	Reduced ²
	Side C	36 – 5180 MHz	Reduced ¹
		40 – 5200 MHz	Reduced ¹
		44 – 5220 MHz	Tested
		48 – 5240 MHz	Reduced ¹
	Side D	36 – 5180 MHz	Reduced ¹
		40 – 5200 MHz	Reduced ¹
		44 – 5220 MHz	Tested
		48 – 5240 MHz	Reduced ¹
	Side E	36 – 5180 MHz	Reduced ²
		40 – 5200 MHz	Reduced ²
		44 – 5220 MHz	Reduced ²
		48 – 5240 MHz	Reduced ²
	Side F	36 – 5180 MHz	Reduced ¹
		40 – 5200 MHz	Reduced ¹
		44 – 5220 MHz	Tested
		48 – 5240 MHz	Reduced ¹
802.11n 5150 MHz	Side A	36 – 5180 MHz	Reduced ¹
		40 – 5200 MHz	Reduced ¹
		44 – 5220 MHz	Reduced ¹
		48 – 5240 MHz	Reduced ¹
	Side B	36 – 5180 MHz	Reduced ²
		40 – 5200 MHz	Reduced ²
		44 – 5220 MHz	Reduced ²
		48 – 5240 MHz	Reduced ²
	Side C	36 – 5180 MHz	Reduced ¹
		40 – 5200 MHz	Reduced ¹
		44 – 5220 MHz	Reduced ¹
		48 – 5240 MHz	Reduced ¹
	Side D	36 – 5180 MHz	Reduced ¹
		40 – 5200 MHz	Reduced ¹
		44 – 5220 MHz	Reduced ¹
		48 – 5240 MHz	Reduced ¹
	Side E	36 – 5180 MHz	Reduced ²
		40 – 5200 MHz	Reduced ²
		44 – 5220 MHz	Reduced ²
		48 – 5240 MHz	Reduced ²
	Side F	36 – 5180 MHz	Reduced ¹
		40 – 5200 MHz	Reduced ¹
		44 – 5220 MHz	Reduced ¹
		48 – 5240 MHz	Reduced ¹

Reduced¹ – When the reported SAR is ≤ 0.4 W/kg, SAR is not required for the remaining test configuration per KDB 248227 D01 v02r02 section 5.1.1 1) page 9.

Reduced² – When the antenna is more than 25 mm from a side, the test can be reduced per KDB447498 D01 v06 section 4.3.1 1) page 11. See below for calculations.

Maximum power: 25.1 mW

Closest Distance to Side D: 57 mm

Closest Distance to Side E: 49 mm

The closest distance is from Side E. Therefore, if Side E is excluded then Side D would also be excluded.

$[(25.1 \text{ mW}) / (49 \text{ mm})]^2 / 5.24 = 1.17$ which is equal to or less than 3.0.

Figure 10.5 Test Reduction Table – WiFi 5.8 GHz Chain 0

Mode	Side	Required Channel	Tested/Reduced
802.11a 5800 MHz	Side A	149 – 5745 MHz	Reduced ¹
		157 – 5785 MHz	Tested
		165 – 5825 MHz	Reduced ¹
	Side B	149 – 5745 MHz	Reduced ¹
		157 – 5785 MHz	Tested
		165 – 5825 MHz	Reduced ¹
	Side C	149 – 5745 MHz	Reduced ¹
		157 – 5785 MHz	Tested
		165 – 5825 MHz	Reduced ¹
	Side D	149 – 5745 MHz	Reduced ²
		157 – 5785 MHz	Reduced ²
		165 – 5825 MHz	Reduced ²
	Side E	149 – 5745 MHz	Reduced ²
		157 – 5785 MHz	Reduced ²
		165 – 5825 MHz	Reduced ²
	Side F	149 – 5745 MHz	Reduced ¹
		157 – 5785 MHz	Tested
		165 – 5825 MHz	Reduced ¹
802.11n 5800 MHz	Side A	149 – 5745 MHz	Reduced ¹
		157 – 5785 MHz	Reduced ¹
		165 – 5825 MHz	Reduced ¹
	Side B	149 – 5745 MHz	Reduced ¹
		157 – 5785 MHz	Reduced ¹
		165 – 5825 MHz	Reduced ¹
	Side C	149 – 5745 MHz	Reduced ¹
		157 – 5785 MHz	Reduced ¹
		165 – 5825 MHz	Reduced ¹
	Side D	149 – 5745 MHz	Reduced ²
		157 – 5785 MHz	Reduced ²
		165 – 5825 MHz	Reduced ²
	Side E	149 – 5745 MHz	Reduced ²
		157 – 5785 MHz	Reduced ²
		165 – 5825 MHz	Reduced ²
	Side F	149 – 5745 MHz	Reduced ¹
		157 – 5785 MHz	Reduced ¹
		165 – 5825 MHz	Reduced ¹

Reduced¹ – When the reported SAR is ≤ 0.4 W/kg, SAR is not required for the remaining test configuration per KDB 248227 D01 v02r02 section 5.1.1 1) page 9.

Reduced² – When the antenna is more than 25 mm from a side, the test can be reduced per KDB447498 D01 v06 section 4.3.1 1) page 11. See below for calculations.

Reduced³ – When the reported SAR is >0.8 W/kg, test the next highest configuration until the SAR value is ≤ 1.2 W/kg per KDB 248227 D01 v02r02 section 5.1.1 3) page 9.

Reduced⁴ – When the reported SAR is >0.4 W/kg, test the next highest configuration until the SAR value is ≤ 0.8 W/kg per KDB 248227 D01 v02r02 section 5.1.1 2) page 9.

Maximum power: 25.1 mW
 Closest Distance to Side D: 57 mm
 Closest Distance to Side E: 49 mm

The closest distance is from Side E. Therefore, if Side E is excluded then Side D would also be excluded.

$[(25.1 \text{ mW}) / (49 \text{ mm})]^2 \cdot 5.825 = 1.23$ which is equal to or less than 3.0.

Figure 10.6 Test Reduction Table – WiFi 5.8 GHz Chain 1

Mode	Side	Required Channel	Tested/Reduced
802.11a 5800 MHz	Side A	149 – 5745 MHz	Reduced ¹
		157 – 5785 MHz	Tested
		165 – 5825 MHz	Reduced ¹
	Side B	149 – 5745 MHz	Reduced ²
		157 – 5785 MHz	Reduced ²
		165 – 5825 MHz	Reduced ²
	Side C	149 – 5745 MHz	Reduced ¹
		157 – 5785 MHz	Tested
		165 – 5825 MHz	Reduced ¹
	Side D	149 – 5745 MHz	Reduced ¹
		157 – 5785 MHz	Tested
		165 – 5825 MHz	Reduced ¹
	Side E	149 – 5745 MHz	Reduced ²
		157 – 5785 MHz	Reduced ²
		165 – 5825 MHz	Reduced ²
	Side F	149 – 5745 MHz	Reduced ¹
		157 – 5785 MHz	Tested
		165 – 5825 MHz	Reduced ¹
802.11n 5800 MHz	Side A	149 – 5745 MHz	Reduced ¹
		157 – 5785 MHz	Reduced ¹
		165 – 5825 MHz	Reduced ¹
	Side B	149 – 5745 MHz	Reduced ²
		157 – 5785 MHz	Reduced ²
		165 – 5825 MHz	Reduced ²
	Side C	149 – 5745 MHz	Reduced ¹
		157 – 5785 MHz	Reduced ¹
		165 – 5825 MHz	Reduced ¹
	Side D	149 – 5745 MHz	Reduced ¹
		157 – 5785 MHz	Reduced ¹
		165 – 5825 MHz	Reduced ¹
	Side E	149 – 5745 MHz	Reduced ²
		157 – 5785 MHz	Reduced ²
		165 – 5825 MHz	Reduced ²
	Side F	149 – 5745 MHz	Reduced ¹
		157 – 5785 MHz	Reduced ¹
		165 – 5825 MHz	Reduced ¹

Reduced¹ – When the reported SAR is ≤ 0.4 W/kg, SAR is not required for the remaining test configuration per KDB 248227 D01 v02r02 section 5.1.1 1) page 9.

Reduced² – When the antenna is more than 25 mm from a side, the test can be reduced per KDB447498 D01 v06 section 4.3.1 1) page 11. See below for calculations.

Reduced³ – When the reported SAR is >0.8 W/kg, test the next highest configuration until the SAR value is ≤ 1.2 W/kg per KDB 248227 D01 v02r02 section 5.1.1 3) page 9.

Reduced⁴ – When the reported SAR is >0.4 W/kg, test the next highest configuration until the SAR value is ≤ 0.8 W/kg per KDB 248227 D01 v02r02 section 5.1.1 2) page 9.

Maximum power: 25.1 mW

Closest Distance to Side D: 57 mm

Closest Distance to Side E: 49 mm

The closest distance is from Side E. Therefore, if Side E is excluded then Side D would also be excluded.

$[(25.1 \text{ mW}) / (49 \text{ mm})]^2 \cdot 5.825 = 1.23$ which is equal to or less than 3.0.

Figure 10.7 Test Reduction Table – 3G 850 MHz

Band/ Frequency (MHz)	Technology	Side	Required Channel	Tested/ Reduced
Band 5 824-849 MHz	WCDMA	Side A	4132	Tested
			4183	Tested
			4233	Tested
		Side B	4132	Reduced ¹
			4183	Tested
			4233	Reduced ¹
		Side C	4132	Reduced ¹
			4183	Tested
			4233	Reduced ¹
		Side D	4132	Reduced ¹
			4183	Tested
			4233	Reduced ¹
		Side E	4132	Reduced ¹
			4183	Tested
			4233	Reduced ¹
		Side F	4132	Reduced ²
			4183	Reduced ²
			4233	Reduced ²
Band 4 1710-1755 MHz	WCDMA	Side A	1312	Tested
			1413	Tested
			1513	Tested
		Side B	1312	Reduced ¹
			1413	Tested
			1513	Reduced ¹
		Side C	1312	Reduced ¹
			1413	Tested
			1513	Reduced ¹
		Side D	1312	Reduced ¹
			1413	Tested
			1513	Reduced ¹
		Side E	1312	Reduced ¹
			1413	Tested
			1513	Reduced ¹
		Side F	1312	Reduced ²
			1413	Reduced ²
			1513	Reduced ²
Band 2 1850-1910 MHz	WCDMA	Side A	9262	Tested
			9400	Tested
			9538	Tested
		Side B	9262	Reduced ¹
			9400	Tested
			9538	Reduced ¹
		Side C	9262	Reduced ¹
			9400	Tested
			9538	Reduced ¹
		Side D	9262	Reduced ¹
			9400	Tested
			9538	Reduced ¹
		Side E	9262	Reduced ¹
			9400	Tested
			9538	Reduced ¹
		Side F	9262	Reduced ²
			9400	Reduced ²
			9538	Reduced ²

Reduced¹ – When the mid channel is 3 dB below the limit, the remaining channels are not required per KDB 447498 D01 v06 section 4.3.3 page 14.

Reduced² – When the antenna is more than 25 mm from a side, the test can be reduced per KDB447498 D01 v06 section 4.3.1 1) page 11. See below for calculations.

Maximum power: 251.2 mW
Closest Distance to Side F: 97 mm

$$\left[\frac{3.0}{\sqrt{0.849}}\right] * 50 \text{ mm} + [97 - 50 \text{ mm}] * 10 = 632 \text{ mW}$$
 which is greater than 251.2 mW

$$\left[\frac{3.0}{\sqrt{1.755}}\right] * 50 \text{ mm} + [97 - 50 \text{ mm}] * 10 = 583 \text{ mW}$$
 which is greater than 251.2 mW

$$\left[\frac{3.0}{\sqrt{1.91}}\right] * 50 \text{ mm} + [97 - 50 \text{ mm}] * 10 = 578 \text{ mW}$$
 which is greater than 251.2 mW

10.5 SAR Measurement Conditions for LTE Bands

10.5.1 LTE Functionality

The follow table identifies all the channel bandwidths in each frequency band supported by this device.

LTE Band Class	Bandwidth (MHz)	Frequency or Freq. Band (MHz)
2	1.4, 3, 5, 10, 15, 20	1850-1910 MHz
4	1.4, 3, 5, 10, 15, 20	1710-1755 MHz
5	1.4, 3, 5, 10	824-849 MHz
13	5, 10	777-787 MHz
48	5, 10, 15, 20	3550-3700 MHz
66	1.4, 3, 5, 10, 15, 20	1710-1780 MHz

10.5.2 Test Conditions

All SAR measurements for LTE were performed using the Anritsu MT8820C. A closed loop power control setting allowed the UE to transmit at the maximum output power during the SAR measurements. The Figure 11.1 table indicates all the test reduction utilized for this report.

MPR was enabled for this device. A-MPR was disabled for all SAR test measurements.

Table 10.5.1 LTE Power Measurements

Band	Bandwidth	RB	Offset	Channel	Freq.	Max Tune Up	QPSK	16QAM			
Band 13 Ant 0	5	1	0	23205	779.5	MIN = 21.3 dBm NOM = 23.0 dBm MAX = 24.0 dBm	23.26	22.71			
				23230	782		23.28	22.90			
				23255	784.5		23.73	22.88			
		1	12	23205	779.5		23.11	22.47			
				23230	782		23.83	23.03			
				23255	784.5		23.91	23.30			
		1	24	23205	779.5		23.82	23.44			
				23230	782		23.95	23.35			
				23255	784.5		23.95	23.46			
		12	0	23205	779.5		22.09	21.33			
				23230	782		22.88	21.88			
				23255	784.5		22.89	21.95			
			12	6	23205		779.5	22.35	21.41		
					23230		782	23.04	22.06		
					23255		784.5	23.08	21.98		
		12	13	23205	779.5		22.95	21.94			
				23230	782		22.98	21.97			
				23255	784.5		23.08	21.98			
		25	0	23205	779.5		22.63	21.64			
				23230	782		22.92	21.92			
				23255	784.5		22.99	21.87			
		10	10	1	0		23230	782	MIN = 21.3 dBm NOM = 23.0 dBm MAX = 24.0 dBm	23.15	22.34
				1	25		23230	782		23.98	23.02
				1	49		23230	782		23.88	22.90
	25			0	23230	782	22.79	21.74			
	25			13	23230	782	22.94	21.85			
	25			25	23230	782	22.83	21.76			
	50			0	23230	782	22.88	21.68			
	UL MCS Index	MCS Index 6 => QPSK, TBS 6					MIN =>	22.09	21.33		
		MCS Index 11 => 16QAM, TBS 10					MAX =>	23.98	23.46		

Band	Bandwidth	RB	Offset	Channel	Freq.	Max Tune Up	QPSK	16QAM
Band 5 Ant 0	1.4	1	0	20407	824.7	MIN = 21.3 dBm NOM = 23.0 dBm MAX = 24.0 dBm	23.69	22.33
				20525	836.5		23.90	23.13
				20643	848.3		23.29	21.97
		1	3	20407	824.7		23.69	22.52
				20525	836.5		24.00	23.26
				20643	848.3		22.90	21.32
		1	5	20407	824.7		23.53	22.22
				20525	836.5		23.99	23.14
				20643	848.3		22.34	21.38
		3	0	20407	824.7		23.78	22.50
				20525	836.5		23.98	22.94
				20643	848.3		23.25	21.78
		3	1	20407	824.7		23.78	22.54
				20525	836.5		24.00	23.09
				20643	848.3		23.13	21.63
		3	3	20407	824.7		23.64	22.34
				20525	836.5		24.00	23.12
				20643	848.3		22.55	21.36
	6	0	20407	824.7	22.82	21.57		
			20525	836.5	23.09	22.09		
			20643	848.3	22.08	21.64		
	3	1	0	20415	825.5	MIN = 21.3 dBm NOM = 23.0 dBm MAX = 24.0 dBm	23.75	22.66
				20525	836.5		23.93	22.87
				20635	847.5		23.81	22.35
		1	7	20415	825.5		23.71	22.42
				20525	836.5		24.00	23.06
				20635	847.5		23.66	22.24
		1	14	20415	825.5		23.65	22.32
				20525	836.5		24.00	22.61
				20635	847.5		22.40	21.38
8		0	20415	825.5	22.91		21.63	
			20525	836.5	23.12		22.18	
			20635	847.5	22.89		21.44	
8	3	20415	825.5	22.85	21.64			
		20525	836.5	23.13	22.30			
		20635	847.5	22.78	21.38			

Band	Bandwidth	RB	Offset	Channel	Freq.	Max Tune Up	QPSK	16QAM		
Band 5 Ant 0	3	8	7	20415	825.5	MIN = 21.3 dBm NOM = 23.0 dBm MAX = 24.0 dBm	22.78	21.59		
				20525	836.5		23.21	22.27		
				20635	847.5		22.26	21.91		
		15	0	20415	825.5		22.84	21.62		
				20525	836.5		23.13	22.17		
				20635	847.5		22.55	21.33		
	5	1	0	20425	826.5	MIN = 21.3 dBm NOM = 23.0 dBm MAX = 24.0 dBm	23.79	22.81		
				20525	836.5		23.79	22.88		
				20625	846.5		23.51	22.20		
		1	12	20425	826.5		23.78	23.13		
				20525	836.5		24.00	23.18		
				20625	846.5		23.98	22.56		
		1	24	20425	826.5		23.84	23.18		
				20525	836.5		23.61	22.32		
				20625	846.5		22.53	21.34		
		12	0	20425	826.5		22.93	21.79		
				20525	836.5		23.06	22.17		
				20625	846.5		22.80	21.42		
			6	20425	826.5		22.92	21.65		
				20525	836.5		23.21	22.24		
				20625	846.5		22.97	21.54		
			13	20425	826.5		22.92	21.61		
				20525	836.5		23.14	22.04		
				20625	846.5		22.55	21.32		
		25	0	20425	826.5		22.87	21.61		
				20525	836.5		23.12	22.04		
				20625	846.5		22.66	21.39		
		10	1	0	20450		829	MIN = 21.3 dBm NOM = 23.0 dBm MAX = 24.0 dBm	23.81	23.11
					20525		836.5		23.79	23.48
					20600		844		23.28	22.53
	1		25	20450	829	23.94	23.44			
				20525	836.5	23.95	23.11			
				20600	844	23.50	22.77			
	1		49	20450	829	23.82	23.37			
				20525	836.5	22.95	22.16			
				20600	844	22.91	21.86			
	25		0	20450	829	22.90	21.80			
				20525	836.5	22.86	21.83			
				20600	844	22.32	21.31			

Band	Bandwidth	RB	Offset	Channel	Freq.	Max Tune Up	QPSK	16QAM
Band 5 Ant 0	10	25	13	20450	829	MIN = 21.3 dBm NOM = 23.0 dBm MAX = 24.0 dBm	22.72	22.00
				20525	836.5		22.87	22.08
				20600	844		22.60	21.31
		25	25	20450	829		22.92	21.84
				20525	836.5		22.87	21.57
				20600	844		22.74	21.37
		50	0	20450	829		22.86	21.92
				20525	836.5		22.98	21.93
				20600	844		22.54	21.32
	UL MCS Index	MCS Index 6 => QPSK, TBS 6		MIN =>		22.08	21.31	
		MCS Index 11 => 16QAM, TBS 10		MAX =>		24.00	23.48	

Band	Bandwidth	RB	Offset	Channel	Freq.	Max Tune Up	QPSK	16QAM
Band 4 Ant 0	3	1	0	19965	1711.5	MIN = 20.3 dBm NOM = 22.0 dBm MAX = 23.0 dBm	21.97	21.30
				20175	1732.5		22.94	22.16
				20385	1753.5		22.82	21.71
		1	7	19965	1711.5		23.13	21.83
				20175	1732.5		23.48	22.74
				20385	1753.5		23.34	22.00
		1	14	19965	1711.5		22.19	21.67
				20175	1732.5		23.35	22.52
				20385	1753.5		23.36	22.58
		8	0	19965	1711.5		22.38	21.70
				20175	1732.5		23.40	22.60
				20385	1753.5		23.85	22.59
		8	3	19965	1711.5		22.49	21.77
				20175	1732.5		23.41	22.64
				20385	1753.5		23.78	22.85
		8	7	19965	1711.5		22.53	21.76
				20175	1732.5		23.08	22.55
				20385	1753.5		23.58	22.04
	15	0	19965	1711.5	22.34	21.55		
			20175	1732.5	23.20	22.58		
			20385	1753.5	23.58	22.92		
	5	1	0	19975	1712.5	MIN = 20.3 dBm NOM = 22.0 dBm MAX = 23.0 dBm	22.87	21.35
				20175	1732.5		23.01	22.95
				20375	1752.5		23.41	22.26
		1	12	19975	1712.5		22.28	21.98
				20175	1732.5		23.48	22.49
				20375	1752.5		23.64	22.68
		1	24	19975	1712.5		22.59	22.03
				20175	1732.5		23.08	22.12
				20375	1752.5		22.55	21.72
12		0	19975	1712.5	22.44		21.60	
			20175	1732.5	23.42		22.31	
			20375	1752.5	23.58		22.76	
12	6	19975	1712.5	22.62	21.76			
		20175	1732.5	23.37	22.63			
		20375	1752.5	23.72	22.92			

Band	Bandwidth	RB	Offset	Channel	Freq.	Max Tune Up	QPSK	16QAM			
Band 4 Ant 0	5	12	13	19975	1712.5	MIN = 20.3 dBm NOM = 22.0 dBm MAX = 23.0 dBm	22.77	21.91			
				20175	1732.5		23.25	22.51			
				20375	1752.5		23.05	22.00			
		25	0	19975	1712.5		22.33	21.56			
				20175	1732.5		22.96	22.30			
				20375	1752.5		23.37	22.62			
	10	1	0	20000	1715	MIN = 20.3 dBm NOM = 22.0 dBm MAX = 23.0 dBm	23.97	21.39			
				20175	1732.5		23.57	22.54			
				20350	1750		23.49	22.77			
		1	25	20000	1715		22.73	22.29			
				20175	1732.5		23.87	22.50			
				20350	1750		23.59	22.35			
		1	49	20000	1715		23.09	22.14			
				20175	1732.5		23.52	22.87			
				20350	1750		23.21	22.83			
		25	0	20000	1715		22.56	21.62			
				20175	1732.5		23.18	22.32			
				20350	1750		22.94	22.40			
			25	13	20000		1715	21.96	21.32		
					20175		1732.5	23.06	22.22		
					20350		1750	23.19	22.38		
		25	25	20000	1715		22.46	21.60			
				20175	1732.5		22.87	22.06			
				20350	1750		23.38	22.57			
		50	0	20000	1715		22.80	21.87			
				20175	1732.5		22.69	21.89			
				20350	1750		22.89	21.96			
			15	1	0		20025	1717.5	MIN = 20.3 dBm NOM = 22.0 dBm MAX = 23.0 dBm	22.27	21.73
							20175	1732.5		23.10	22.57
							20325	1747.5		23.14	22.49
	1	37		20025	1717.5	23.45	22.96				
				20175	1732.5	23.17	22.35				
				20325	1747.5	23.43	22.50				
	1	74		20025	1717.5	23.14	22.42				
				20175	1732.5	22.86	22.01				
				20325	1747.5	23.15	22.03				
	36	0		20025	1717.5	22.89	21.33				
				20175	1732.5	23.33	22.50				
				20325	1747.5	22.75	21.95				

Band	Bandwidth	RB	Offset	Channel	Freq.	Max Tune Up	QPSK	16QAM			
Band 4 Ant 0	15	36	19	20025	1717.5	MIN = 20.3 dBm NOM = 22.0 dBm MAX = 23.0 dBm	22.55	21.64			
				20175	1732.5		23.08	22.29			
				20325	1747.5		23.02	22.22			
		36	39	20025	1717.5		23.07	22.20			
				20175	1732.5		22.82	22.04			
				20325	1747.5		23.36	22.37			
		75	0	20025	1717.5		22.36	21.31			
				20175	1732.5		22.78	21.79			
				20325	1747.5		22.71	21.76			
		20	1	0	20050		1720	MIN = 20.3 dBm NOM = 22.0 dBm MAX = 23.0 dBm	22.52	21.91	
					20175		1732.5		22.80	22.93	
					20300		1745		22.69	22.35	
	1		49	20050	1720	23.66	22.43				
				20175	1732.5	23.73	22.06				
				20300	1745	23.32	22.20				
	1		99	20050	1720	22.44	21.61				
				20175	1732.5	22.86	21.77				
				20300	1745	22.59	21.95				
	50		0	20050	1720	22.70	21.31				
				20175	1732.5	23.13	22.31				
				20300	1745	22.90	21.67				
	50		25	20050	1720	23.35	21.94				
				20175	1732.5	23.27	22.03				
				20300	1745	23.03	21.32				
	50		50	20050	1720	23.52	22.16				
				20175	1732.5	22.95	21.70				
				20300	1745	23.33	22.02				
	100		0	20050	1720	23.08	21.54				
				20175	1732.5	23.18	21.85				
				20300	1745	23.05	21.70				
	UL MCS Index		MCS Index 6 => QPSK, TBS 6						MIN =>	21.96	21.30
			MCS Index 11 => 16QAM, TBS 10						MAX =>	23.97	22.96

Band	Bandwidth	RB	Offset	Channel	Freq.	Max Tune Up	QPSK	16QAM	
Band 66 Ant 0	3	1	0	131987	1711.5	MIN = 20.3 dBm NOM = 22.0 dBm MAX = 23.0 dBm	22.81	21.92	
				132322	1745		22.48	21.31	
				132657	1778.5		22.18	21.32	
		1	7	131987	1711.5		22.10	22.00	
				132322	1745		22.57	21.76	
				132657	1778.5		22.31	21.96	
		1	14	131987	1711.5		22.60	21.33	
				132322	1745		22.43	21.36	
				132657	1778.5		22.07	21.37	
		8	0	131987	1711.5		22.07	21.34	
				132322	1745		22.92	21.31	
				132657	1778.5		22.36	21.31	
		8	3	131987	1711.5		22.06	21.34	
				132322	1745		21.92	21.36	
				132657	1778.5		22.43	21.32	
		8	7	131987	1711.5		21.97	21.99	
				132322	1745		21.92	21.81	
				132657	1778.5		22.70	21.39	
	15	0	131987	1711.5	22.11	21.38			
			132322	1745	22.09	21.94			
			132657	1778.5	22.32	21.30			
	5	1	0	131997	1712.5	MIN = 20.3 dBm NOM = 22.0 dBm MAX = 23.0 dBm	22.76	21.54	
				132322	1745		22.67	21.67	
				132647	1777.5		22.05	21.30	
			12	12	131997		1712.5	22.34	21.38
					132322		1745	22.90	21.97
					132647		1777.5	22.16	21.94
			24	24	131997		1712.5	22.64	21.85
					132322		1745	22.50	21.55
					132647		1777.5	22.86	21.81
		12	0	131997	1712.5		22.20	21.88	
				132322	1745		22.89	21.83	
				132647	1777.5		22.40	21.39	
		12	6	131997	1712.5		22.13	21.33	
				132322	1745		22.11	21.88	
				132647	1777.5		22.47	21.36	
12		13	131997	1712.5	22.21		21.94		
			132322	1745	22.02		21.69		
			132647	1777.5	22.32		21.39		

Band	Bandwidth	RB	Offset	Channel	Freq.	Max Tune Up	QPSK	16QAM		
Band 66 Ant 0	5	25	0	131997	1712.5	MIN = 21.3 dBm NOM = 23.0 dBm MAX = 24.0 dBm	22.35	21.31		
				132322	1745		22.52	21.73		
				132647	1777.5		22.63	21.63		
	10	1	0	132022	1715	MIN = 20.3 dBm NOM = 22.0 dBm MAX = 23.0 dBm	22.96	21.34		
				132322	1745		22.03	21.44		
				132622	1775		22.09	21.50		
		1	25	132022	1715		22.86	22.04		
				132322	1745		22.93	21.42		
				132622	1775		22.37	21.46		
		1	49	132022	1715		22.90	21.38		
				132322	1745		22.92	21.51		
				132622	1775		22.26	21.44		
		25	0	132022	1715		22.84	21.77		
				132322	1745		22.87	21.37		
				132622	1775		22.10	21.37		
			25	13	132022		1715	22.24	21.88	
					132322		1745	22.45	21.69	
					132622		1775	22.77	21.86	
			25	25	132022		1715	22.09	21.77	
					132322		1745	22.62	21.32	
					132622		1775	22.59	21.72	
		50	0	132022	1715		22.83	21.37		
				132322	1745		22.10	21.88		
				132622	1775		22.61	21.42		
			1	0	132047		1717.5	22.45	21.73	
					132322		1745	22.44	21.60	
					132597		1772.5	22.47	21.57	
		15	1	37	132047		1717.5	MIN = 20.3 dBm NOM = 22.0 dBm MAX = 23.0 dBm	23.05	21.83
					132322		1745		22.98	21.91
					132597		1772.5		22.35	21.40
	1		74	132047	1717.5	22.65	21.52			
				132322	1745	22.18	21.75			
				132597	1772.5	22.24	21.40			
	36	0	132047	1717.5	22.14	21.86				
			132322	1745	22.94	21.87				
			132597	1772.5	22.33	21.86				
	36	19	132047	1717.5	22.25	21.38				
			132322	1745	22.02	21.83				
			132597	1772.5	22.15	21.39				

Band	Bandwidth	RB	Offset	Channel	Freq.	Max Tune Up	QPSK	16QAM			
Band 66 Ant 0	15	36	39	132047	1717.5	MIN = 20.3 dBm NOM = 22.0 dBm MAX = 23.0 dBm	22.93	21.93			
				132322	1745		22.88	21.78			
				132597	1772.5		22.26	21.82			
		75	0	132047	1717.5		22.18	21.76			
				132322	1745		22.24	21.56			
				132597	1772.5		22.37	21.34			
	20	1	0	132072	1720	MIN = 20.3 dBm NOM = 22.0 dBm MAX = 23.0 dBm	22.24	21.36			
				132322	1745		22.16	21.34			
				132572	1770		23.25	21.43			
		1	49	132072	1720		23.11	21.98			
				132322	1745		23.07	21.43			
				132572	1770		22.57	21.56			
		1	99	132072	1720		22.13	21.35			
				132322	1745		22.14	21.32			
				132572	1770		22.36	21.37			
		50	0	132072	1720		22.28	21.39			
				132322	1745		22.50	21.30			
				132572	1770		23.08	21.36			
			50	25	132072		1720	22.83	21.94		
					132322		1745	22.37	21.37		
					132572		1770	22.33	21.86		
		50	50	132072	1720		22.51	21.41			
				132322	1745		22.85	21.86			
				132572	1770		22.70	21.77			
		100	0	132072	1720		22.55	21.32			
				132322	1745		22.97	21.44			
				132572	1770		22.51	21.37			
		UL MCS Index	MCS Index 6 => QPSK, TBS 6					MIN =>	21.92	21.30	
			MCS Index 11 => 16QAM, TBS 10					MAX =>	23.25	22.04	

Band	Bandwidth	RB	Offset	Channel	Freq.	Max Tune Up	QPSK	16QAM	
Band 2 Ant 0	3	1	0	18615	1851.5	MIN = 20.3 dBm NOM = 22.0 dBm MAX = 22.5 dBm	22.00	20.64	
				18900	1880		22.00	20.83	
				19185	1908.5		22.00	21.66	
		1	7	18615	1851.5		22.00	21.60	
				18900	1880		22.00	21.95	
				19185	1908.5		22.00	20.64	
		1	14	18615	1851.5		22.00	21.45	
				18900	1880		22.00	20.54	
				19185	1908.5		22.00	20.81	
		8	0	18615	1851.5		21.77	20.46	
				18900	1880		21.70	20.73	
				19185	1908.5		21.78	20.34	
		8	3	18615	1851.5		21.85	20.53	
				18900	1880		21.85	20.79	
				19185	1908.5		21.94	20.37	
		8	7	18615	1851.5		21.74	20.53	
				18900	1880		21.75	20.79	
				19185	1908.5		21.69	20.91	
	15	0	18615	1851.5	21.80	20.41			
			18900	1880	21.89	20.78			
			19185	1908.5	21.84	20.32			
	5	1	0	18625	1852.5	MIN = 20.3 dBm NOM = 22.0 dBm MAX = 22.5 dBm	22.00	21.14	
				18900	1880		22.00	21.10	
				19175	1907.5		22.00	20.94	
			12	12	18625		1852.5	21.89	20.32
					18900		1880	22.00	21.32
					19175		1907.5	22.00	21.82
			24	24	18625		1852.5	22.00	20.80
					18900		1880	22.00	20.94
					19175		1907.5	22.00	20.58
		12	0	18625	1852.5		21.67	20.36	
				18900	1880		21.70	20.33	
				19175	1907.5		21.68	20.35	
		12	6	18625	1852.5		21.78	20.30	
				18900	1880		21.79	20.44	
				19175	1907.5		21.84	20.44	
12		13	18625	1852.5	21.69		20.36		
			18900	1880	21.73		20.35		
			19175	1907.5	21.85		20.34		

Band	Bandwidth	RB	Offset	Channel	Freq.	Max Tune Up	QPSK	16QAM	
Band 2 Ant 0	5	25	0	18625	1852.5	MIN = 20.3 dBm NOM = 22.0 dBm MAX = 22.5 dBm	21.76	20.39	
				18900	1880		21.69	20.43	
				19175	1907.5		21.71	20.32	
	10	1	0	18650	1855	MIN = 20.3 dBm NOM = 22.0 dBm MAX = 22.5 dBm	21.68	20.40	
				18900	1880		21.69	20.58	
				19150	1905		22.45	20.97	
		1	25	18650	1855		21.83	21.27	
				18900	1880		22.00	20.31	
				19150	1905		22.00	20.36	
		1	49	18650	1855		21.43	20.71	
				18900	1880		21.48	20.52	
				19150	1905		22.00	20.31	
		25	0	18650	1855		21.06	20.36	
				18900	1880		21.28	20.37	
				19150	1905		21.03	20.79	
			25	13	18650		1855	21.21	20.39
					18900		1880	21.47	20.42
					19150		1905	21.28	20.37
			25	25	18650		1855	21.89	20.89
					18900		1880	21.17	20.38
					19150		1905	21.97	20.38
		50	0	18650	1855		21.10	20.34	
				18900	1880		21.20	20.35	
				19150	1905		21.03	20.38	
			1	0	18675		1857.5	22.00	20.33
					18900		1880	22.00	21.58
					19125		1902.5	21.14	20.81
		1	37	18675	1857.5		22.00	21.45	
				18900	1880		22.00	21.66	
				19125	1902.5		22.00	21.45	
	1	74	18675	1857.5	21.67	20.34			
			18900	1880	22.00	21.67			
			19125	1902.5	22.00	21.21			
	36	0	18675	1857.5	21.27	20.31			
			18900	1880	21.58	20.45			
			19125	1902.5	21.85	20.57			
	36	19	18675	1857.5	21.32	20.31			
			18900	1880	21.59	20.51			
			19125	1902.5	21.29	20.87			

Band	Bandwidth	RB	Offset	Channel	Freq.	Max Tune Up	QPSK	16QAM	
Band 2 Ant 0	15	36	39	18675	1857.5	MIN = 20.3 dBm NOM = 22.0 dBm MAX = 22.5 dBm	21.21	20.34	
				18900	1880		21.32	20.33	
				19125	1902.5		21.20	20.34	
		75	0	18675	1857.5		21.10	20.31	
				18900	1880		21.49	20.30	
				19125	1902.5		21.16	20.36	
	20	1	0	18700	1860	MIN = 20.3 dBm NOM = 22.0 dBm MAX = 22.5 dBm	22.00	20.61	
				18900	1880		22.00	21.72	
				19100	1900		22.00	20.77	
		1	49	18700	1860		22.00	21.47	
				18900	1880		22.00	21.75	
				19100	1900		21.57	20.64	
		1	99	18700	1860		22.00	21.35	
				18900	1880		22.00	21.33	
				19100	1900		22.00	21.16	
		50	0	18700	1860		21.57	20.31	
				18900	1880		21.51	20.36	
				19100	1900		21.91	20.32	
			50	25	18700		1860	21.42	20.31
					18900		1880	21.56	20.37
					19100		1900	21.12	20.92
			50	50	18700		1860	21.07	20.95
					18900		1880	21.21	20.31
					19100		1900	21.10	20.95
		100	0	18700	1860		21.26	20.39	
				18900	1880		21.25	20.34	
				19100	1900		21.19	20.33	
		UL MCS Index	MCS Index 6 => QPSK, TBS 6		MIN =>		21.03	20.30	
			MCS Index 11 => 16QAM, TBS 10		MAX =>		22.84	21.95	

Band	Bandwidth	RB	Offset	Channel	Freq.	Max Tune Up	QPSK	16QAM
Band 48 Ant 4	5	1	0	55265	3552.5	MIN = 21.3 dBm NOM = 23.0 dBm MAX = 24.0 dBm	23.14	21.96
				55630	3589		23.07	22.16
				55990	3625		23.11	22.42
				56350	3661		23.52	22.60
				56715	3697.5		22.85	22.34
		1	12	55265	3552.5		23.10	22.01
				55630	3589		23.36	22.28
				55990	3625		23.37	22.61
				56350	3661		23.78	22.68
				56715	3697.5		23.07	22.45
		1	24	55265	3552.5		22.99	21.95
				55630	3589		23.19	22.29
				55990	3625		23.24	22.63
				56350	3661		23.70	22.64
				56715	3697.5		22.80	22.24
		12	0	55265	3552.5		22.73	21.47
				55630	3589		22.66	21.52
				55990	3625		22.52	21.60
				56350	3661		22.99	21.95
				56715	3697.5		22.46	22.24
		12	6	55265	3552.5		22.57	21.53
				55630	3589		22.63	21.70
				55990	3625		22.53	21.67
				56350	3661		23.01	22.04
				56715	3697.5		23.37	22.33
		12	13	55265	3552.5		22.48	21.55
				55630	3589		22.54	21.63
				55990	3625		22.52	21.61
				56350	3661		23.01	22.10
				56715	3697.5		23.36	22.29
25	0	55265	3552.5	22.45	21.49			
		55630	3589	22.58	21.60			
		55990	3625	22.50	21.62			
		56350	3661	23.00	22.10			
		56715	3697.5	23.24	22.39			

Band	Bandwidth	RB	Offset	Channel	Freq.	Max Tune Up	QPSK	16QAM
Band 48 Ant 4	10	1	0	55290	3555	MIN = 21.3 dBm NOM = 23.0 dBm MAX = 24.0 dBm	22.89	22.05
				55640	3590		23.06	22.24
				55990	3625		23.11	22.40
				56340	3660		23.40	22.55
				56690	3695		22.93	22.39
		1	25	55290	3555		22.86	21.97
				55640	3590		23.17	22.28
				55990	3625		23.51	22.62
				56340	3660		23.60	22.69
				56690	3695		23.10	22.48
		1	49	55290	3555		22.85	21.99
				55640	3590		23.14	22.29
				55990	3625		23.28	22.74
				56340	3660		23.49	22.61
				56690	3695		22.67	22.21
		25	0	55290	3555		22.41	21.41
				55640	3590		22.88	21.50
				55990	3625		22.48	21.42
				56340	3660		22.85	21.95
				56690	3695		23.26	22.32
		25	13	55290	3555		22.40	21.46
				55640	3590		22.71	21.67
				55990	3625		22.58	21.52
				56340	3660		23.01	22.03
				56690	3695		23.35	22.42
		25	25	55290	3555		22.44	21.50
				55640	3590		22.62	21.71
				55990	3625		22.65	21.68
				56340	3660		22.98	22.05
				56690	3695		23.39	22.30
		50	0	55290	3555		22.28	21.45
				55640	3590		22.70	21.70
55990	3625			22.53	21.67			
56340	3660			22.99	22.03			
56690	3695			23.31	22.41			

Band	Bandwidth	RB	Offset	Channel	Freq.	Max Tune Up	QPSK	16QAM
Band 48 Ant 4	15	1	0	55315	3557.5	MIN = 21.3 dBm NOM = 23.0 dBm MAX = 24.0 dBm	22.78	21.99
				55650	3591		22.96	22.16
				55990	3625		23.13	22.32
				56330	3659		23.30	22.48
				56665	3692.5		23.14	22.84
		1	37	55315	3557.5		22.73	21.92
				55650	3591		23.08	22.27
				55990	3625		23.37	22.55
				56330	3659		23.43	22.60
				56665	3692.5		23.09	22.45
		1	74	55315	3557.5		22.80	22.01
				55650	3591		23.13	22.35
				55990	3625		23.36	22.81
				56330	3659		23.44	22.66
				56665	3692.5		22.73	22.20
		36	0	55315	3557.5		22.51	21.59
				55650	3591		22.69	21.78
				55990	3625		22.61	21.62
				56330	3659		23.04	22.04
				56665	3692.5		23.52	22.36
		36	19	55315	3557.5		22.52	21.56
				55650	3591		22.80	21.84
				55990	3625		22.64	21.71
				56330	3659		23.09	22.16
				56665	3692.5		23.44	22.49
		36	39	55315	3557.5		22.62	21.57
				55650	3591		22.69	21.75
				55990	3625		22.75	21.73
				56330	3659		23.11	22.00
				56665	3692.5		23.45	22.40
		75	0	55315	3557.5		22.28	21.54
				55650	3591		22.69	21.76
				55990	3625		22.66	21.71
				56330	3659		23.09	22.19
				56665	3692.5		23.43	22.44

Band	Bandwidth	RB	Offset	Channel	Freq.	Max Tune Up	QPSK	16QAM		
Band 48 Ant 4	20	1	0	55340	3560	MIN = 21.3 dBm NOM = 23.0 dBm MAX = 24.0 dBm	22.73	22.07		
				55665	3592.5		22.96	22.27		
				55990	3625		23.14	22.45		
				56315	3657.5		23.59	22.90		
				56640	3690		23.47	23.11		
		1	49	55340	3560		22.78	22.00		
				55665	3592.5		23.09	22.31		
				55990	3625		23.38	22.61		
				56315	3657.5		23.78	23.00		
				56640	3690		23.35	22.71		
		1	99	55340	3560		23.08	22.32		
				55665	3592.5		23.29	22.53		
				55990	3625		23.40	22.75		
				56315	3657.5		23.86	23.11		
				56640	3690		22.84	22.44		
		50	0	55340	3560		22.54	21.55		
				55665	3592.5		22.77	21.83		
				55990	3625		22.61	21.69		
				56315	3657.5		23.03	22.14		
				56640	3690		23.61	22.46		
		50	25	55340	3560		22.45	21.56		
				55665	3592.5		22.81	21.79		
				55990	3625		22.64	21.81		
				56315	3657.5		23.08	22.20		
				56640	3690		23.73	22.54		
		50	50	55340	3560		22.57	21.72		
				55665	3592.5		22.79	21.86		
				55990	3625		22.85	21.88		
				56315	3657.5		23.20	22.12		
				56640	3690		23.78	22.51		
		100	0	55340	3560		22.36	21.55		
				55665	3592.5		22.65	21.71		
				55990	3625		22.76	21.79		
				56315	3657.5		23.08	22.19		
				56640	3690		23.46	22.72		
		UL MCS Index	MCS Index 6 => QPSK, TBS 6				MIN =>	22.28	21.41	
			MCS Index 11 => 16QAM, TBS 10							
		UL TDD Configuration	UL/DL Configuration 1				MAX =>	23.86	23.11	
			Special Subframe 6							

Table 10.5.2 Test Reduction Table – LTE

Band/ Frequency (MHz)	Side	Required Test Channel	Bandwidth	Modulation	RB Allocation	RB Offset	Tested/ Reduced	
Band 2 1850-1910 MHz	A	18700	20 MHz	QPSK	50	0	Tested	
		18900					Tested	
		19100					Tested	
		18700			100	0	Reduced ¹	
		18900					Reduced ¹	
		19100					Tested	
		18700			1	49	Tested	
		18900					Tested	
		19100					Tested	
		18700			99	99	Reduced ²	
		18900					Reduced ²	
		19100					Reduced ²	
		18700		50	25	Reduced ³		
		18900				Reduced ³		
		19100				Reduced ³		
		18700		100	0	Reduced ¹		
		18900				Reduced ¹		
		19100				Reduced ¹		
		18700		1	49	Reduced ⁴		
		18900				Reduced ⁴		
		19100				Reduced ⁴		
		18700		99	99	Reduced ⁴		
		18900				Reduced ⁴		
		19100				Reduced ⁴		
	All lower bandwidths (15 MHz, 10 MHz, 5 MHz, 3 MHz, 1.4 MHz)							Reduced ⁵
	B	QPSK	18700	20 MHz	50	25	Reduced ⁶	
			18900				Tested	
			19100				Reduced ⁶	
			18700		100	0	Reduced ¹	
			18900				Reduced ¹	
			19100				Reduced ¹	
			18700		1	49	Reduced ²	
			18900				Tested	
			19100				Reduced ²	
			18700		99	99	Reduced ²	
			18900				Reduced ²	
			19100				Reduced ²	
		18700	50		25	Reduced ³		
		18900				Reduced ³		
		19100				Reduced ³		
		18700	100		0	Reduced ¹		
		18900				Reduced ¹		
		19100				Reduced ¹		
		18700	1		49	Reduced ⁴		
		18900				Reduced ⁴		
		19100				Reduced ⁴		
		18700	99		99	Reduced ⁴		
		18900				Reduced ⁴		
19100		Reduced ⁴						
All lower bandwidths (15 MHz, 10 MHz, 5 MHz, 3 MHz, 1.4 MHz)							Reduced ⁵	

Reduced¹ – If the SAR value in the 50% RB testing is less than 1.45 W/kg, the 100% RB testing is reduced per KDB941225 D05 3) A) I) page 4.
 Reduced² - If the SAR value in the 1 RB testing is less than 1.45 W/kg, the remaining channels are reduced per KDB941225 D05 3) B) I) page 4.
 Reduced³ - If the SAR value in the 50% RB testing is less than 1.45 W/kg, the remaining channels are reduced per KDB941225 D05 4) A) I) page 4.
 Reduced⁴- If the SAR value in the 1 RB testing is less than 1.45 W/kg, the remaining channels are reduced per KDB941225 D05 4) B) I) page 5.
 Reduced⁵- If the conducted power is within ±0.5 dB, all testing where the SAR value is less than 1.45 W/kg is reduced per KDB941225 D05 5) B) I) page 5.

Reduced⁶- If the SAR value measured on the middle channel is less than 0.8 W/kg and the conducted power is within ±0.5 dB, the remaining channels are reduced per KDB941225 D05 page 4 footnote 2.

Band/ Frequency (MHz)	Side	Required Test Channel	Bandwidth	Modulation	RB Allocation	RB Offset	Tested/ Reduced	
Band 2 1850-1910 MHz	C	18700	20 MHz	QPSK	50	25	Reduced ⁶	
		18900					Tested	
		19100					Reduced ⁶	
		18700			100	0	Reduced ¹	
		18900					Reduced ¹	
		19100					Reduced ¹	
		18700			1	49	Reduced ⁶	
		18900					Tested	
		19100					Reduced ⁶	
		18700			99	99	Reduced ²	
		18900					Reduced ²	
		19100					Reduced ²	
		18700		16QAM	50	25	Reduced ³	
		18900					Reduced ³	
		19100					Reduced ³	
		18700			100	0	Reduced ¹	
		18900					Reduced ¹	
		19100					Reduced ¹	
		18700			1	49	Reduced ⁴	
		18900					Reduced ⁴	
		19100					Reduced ⁴	
		18700			99	99	Reduced ⁴	
		18900					Reduced ⁴	
		19100					Reduced ⁴	
	All lower bandwidths (15 MHz, 10 MHz, 5 MHz, 3 MHz, 1.4 MHz)							Reduced ⁵
	D	QPSK	18700	20 MHz	50	25	Reduced ⁶	
			18900				Tested	
			19100				Reduced ⁶	
			18700		100	0	Reduced ¹	
			18900				Reduced ¹	
			19100				Reduced ¹	
			18700		1	49	Reduced ⁶	
			18900				Tested	
			19100				Reduced ⁶	
			18700		99	99	Reduced ²	
			18900				Reduced ²	
			19100				Reduced ²	
		18700	16QAM		50	25	Reduced ³	
		18900					Reduced ³	
		19100					Reduced ³	
		18700			100	0	Reduced ¹	
		18900					Reduced ¹	
		19100					Reduced ¹	
		18700			1	49	Reduced ⁴	
		18900					Reduced ⁴	
		19100					Reduced ⁴	
		18700			99	99	Reduced ⁴	
		18900					Reduced ⁴	
19100		Reduced ⁴						
All lower bandwidths (15 MHz, 10 MHz, 5 MHz, 3 MHz, 1.4 MHz)							Reduced ⁵	

Reduced¹ - If the SAR value in the 50% RB testing is less than 1.45 W/kg, the 100% RB testing is reduced per KDB941225 D05 3) A) I) page 4.
 Reduced² - If the SAR value in the 1 RB testing is less than 1.45 W/kg, the remaining channels are reduced per KDB941225 D05 3) B) I) page 4.
 Reduced³ - If the SAR value in the 50% RB testing is less than 1.45 W/kg, the remaining channels are reduced per KDB941225 D05 4) A) I) page 4.
 Reduced⁴ - If the SAR value in the 1 RB testing is less than 1.45 W/kg, the remaining channels are reduced per KDB941225 D05 4) B) I) page 5.
 Reduced⁵ - If the conducted power is within ±0.5 dB, all testing where the SAR value is less than 1.45 W/kg is reduced per KDB941225 D05 5) B) I) page 5.

Reduced⁶- If the SAR value measured on the middle channel is less than 0.8 W/kg and the conducted power is within ±0.5 dB, the remaining channels are reduced per KDB941225 D05 page 4 footnote 2.

Band/ Frequency (MHz)	Side	Required Test Channel	Bandwidth	Modulation	RB Allocation	RB Offset	Tested/ Reduced
Band 2 1850-1910 MHz	E	18700	20 MHz	QPSK	50	25	Reduced ⁶
		18900					Tested
		19100					Reduced ⁶
		18700			100	0	Reduced ¹
		18900					Reduced ¹
		19100					Reduced ¹
		18700			1	49	Reduced ⁶
		18900					Tested
		19100					Reduced ⁶
		18700			99	99	Reduced ²
		18900					Reduced ²
		19100					Reduced ²
		18700		16QAM	50	25	Reduced ³
		18900					Reduced ³
		19100					Reduced ³
		18700			100	0	Reduced ¹
		18900					Reduced ¹
		19100					Reduced ¹
		18700			1	49	Reduced ⁴
		18900					Reduced ⁴
		19100					Reduced ⁴
		18700			99	99	Reduced ⁴
		18900					Reduced ⁴
		19100					Reduced ⁴
All lower bandwidths (15 MHz, 10 MHz, 5 MHz, 3 MHz, 1.4 MHz)							Reduced ⁵

Reduced¹ – If the SAR value in the 50% RB testing is less than 1.45 W/kg, the 100% RB testing is reduced per KDB941225 D05 3) A) I) page 4.

Reduced² - If the SAR value in the 1 RB testing is less than 1.45 W/kg, the remaining channels are reduced per KDB941225 D05 3) B) I) page 4.

Reduced³ - If the SAR value in the 50% RB testing is less than 1.45 W/kg, the remaining channels are reduced per KDB941225 D05 4) A) I) page 4.

Reduced⁴- If the SAR value in the 1 RB testing is less than 1.45 W/kg, the remaining channels are reduced per KDB941225 D05 4) B) I) page 5.

Reduced⁵- If the conducted power is within ±0.5 dB, all testing where the SAR value is less than 1.45 W/kg is reduced per KDB941225 D05 5) B) I) page 5.

Reduced⁶- If the SAR value measured on the middle channel is less than 0.8 W/kg and the conducted power is within ±0.5 dB, the remaining channels are reduced per KDB941225 D05 page 4 footnote 2.

Side F Reduced based on distance in KDB 447498 D01 v06 (See below calculations).

Maximum power: 251.2 mW

Closest Distance to Side F: 97 mm

$$[[{(3.0)/(\sqrt{1.91})]*50 \text{ mm}}]+{(97-50 \text{ mm})}*10]=578 \text{ mW}$$

which is greater than 251.2 mW

Band/ Frequency (MHz)	Side	Required Test Channel	Bandwidth	Modulation	RB Allocation	RB Offset	Tested/ Reduced			
Band 66 1710-1780 MHz	A	132072	20 MHz	QPSK	50	25	Reduced ⁶			
		132322					Tested			
		132572					Reduced ⁶			
		132072					100	0	Reduced ¹	
		132322							Reduced ¹	
		132572			Tested					
		132072			1	49			Tested	
		132322							Tested	
		132572					Tested			
		132072					99	25	Reduced ²	
		132322		Reduced ²						
		132572		Reduced ²						
		132072		50	25	Reduced ³				
		132322				Reduced ³				
		132572				Reduced ³				
		132072				100	0	Reduced ¹		
		132322						Reduced ¹		
		132572		Reduced ¹						
		132072		1	49			Reduced ⁴		
		132322						Reduced ⁴		
	132572	Reduced ⁴								
	132072	99	25			Reduced ⁴				
	132322					Reduced ⁴				
	132572			Reduced ⁴						
	All lower bandwidths (15 MHz, 10 MHz, 5 MHz, 3 MHz, 1.4 MHz)							Reduced ⁵		
	B			QPSK	132072	20 MHz	50	25	Reduced ⁶	
		132322	Tested							
		132572	Reduced ⁶							
		132072	100		0				Reduced ¹	
		132322							Reduced ¹	
		132572					Reduced ¹			
		132072					1	49	Reduced ⁶	
		132322							Tested	
		132572	Reduced ⁶							
		132072	99		25				Reduced ²	
		132322		Reduced ²						
		132572		Reduced ²						
		132072		50			25	Reduced ³		
		132322						Reduced ³		
		132572	Reduced ³							
		132072	100		0			Reduced ¹		
		132322						Reduced ¹		
		132572		Reduced ¹						
		132072		1			49	Reduced ⁴		
132322		Reduced ⁴								
132572		Reduced ⁴								
132072		99	25		Reduced ⁴					
132322					Reduced ⁴					
132572				Reduced ⁴						
All lower bandwidths (15 MHz, 10 MHz, 5 MHz, 3 MHz, 1.4 MHz)							Reduced ⁵			

Reduced¹ - If the SAR value in the 50% RB testing is less than 1.45 W/kg, the 100% RB testing is reduced per KDB941225 D05 3) A) I) page 4.
 Reduced² - If the SAR value in the 1 RB testing is less than 1.45 W/kg, the remaining channels are reduced per KDB941225 D05 3) B) I) page 4.
 Reduced³ - If the SAR value in the 50% RB testing is less than 1.45 W/kg, the remaining channels are reduced per KDB941225 D05 4) A) I) page 4.
 Reduced⁴ - If the SAR value in the 1 RB testing is less than 1.45 W/kg, the remaining channels are reduced per KDB941225 D05 4) B) I) page 5.
 Reduced⁵ - If the conducted power is within ±0.5 dB, all testing where the SAR value is less than 1.45 W/kg is reduced per KDB941225 D05 5) B) I) page 5.
 Reduced⁶ - If the SAR value measured on the middle channel is less than 0.8 W/kg and the conducted power is within ±0.5 dB, the remaining channels are reduced per KDB941225 D05 page 4 footnote 2.

Band/ Frequency (MHz)	Side	Required Test Channel	Bandwidth	Modulation	RB Allocation	RB Offset	Tested/ Reduced	
Band 66 1710-1780 MHz	C	132072	20 MHz	QPSK	50	25	Reduced ⁶	
		132322					Tested	
		132572			100	0	Reduced ⁶	
		132072					Reduced ¹	
		132322			1	49	Reduced ¹	
		132572					Reduced ⁶	
		132072			99	49	Tested	
		132322					Reduced ⁶	
		132572			1	99	Reduced ²	
		132072					Reduced ²	
		132322		50	25	Reduced ²		
		132572				Reduced ³		
		132072		100	0	Reduced ³		
		132322				Reduced ³		
		132572		1	49	Reduced ¹		
		132072				Reduced ¹		
		132322		99	49	Reduced ¹		
		132572				Reduced ⁴		
		132072		1	99	Reduced ⁴		
		132322				Reduced ⁴		
	132572	1	99	Reduced ⁴				
	132072			Reduced ⁴				
	132322	1	99	Reduced ⁴				
	132572			Reduced ⁴				
	All lower bandwidths (15 MHz, 10 MHz, 5 MHz, 3 MHz, 1.4 MHz)							Reduced ⁵
	D	QPSK	132072	20 MHz	50	25	Reduced ⁶	
			132322				Tested	
			132572		100	0	Reduced ⁶	
			132072				Reduced ¹	
			132322		1	49	Reduced ¹	
			132572				Reduced ⁶	
			132072		99	49	Tested	
			132322				Reduced ⁶	
			132572		1	99	Reduced ²	
			132072				Reduced ²	
		132322	50	25	Reduced ²			
		132572			Reduced ³			
		132072	100	0	Reduced ³			
		132322			Reduced ³			
		132572	1	49	Reduced ¹			
		132072			Reduced ¹			
		132322	99	49	Reduced ¹			
		132572			Reduced ⁴			
		132072	1	99	Reduced ⁴			
132322		Reduced ⁴						
132572		1	99	Reduced ⁴				
132072				Reduced ⁴				
132322		1	99	Reduced ⁴				
132572				Reduced ⁴				
All lower bandwidths (15 MHz, 10 MHz, 5 MHz, 3 MHz, 1.4 MHz)							Reduced ⁵	

Reduced¹ - If the SAR value in the 50% RB testing is less than 1.45 W/kg, the 100% RB testing is reduced per KDB941225 D05 3) A) I) page 4.
 Reduced² - If the SAR value in the 1 RB testing is less than 1.45 W/kg, the remaining channels are reduced per KDB941225 D05 3) B) I) page 4.
 Reduced³ - If the SAR value in the 50% RB testing is less than 1.45 W/kg, the remaining channels are reduced per KDB941225 D05 4) A) I) page 4.
 Reduced⁴ - If the SAR value in the 1 RB testing is less than 1.45 W/kg, the remaining channels are reduced per KDB941225 D05 4) B) I) page 5.
 Reduced⁵ - If the conducted power is within ±0.5 dB, all testing where the SAR value is less than 1.45 W/kg is reduced per KDB941225 D05 5) B) I) page 5.
 Reduced⁶ - If the SAR value measured on the middle channel is less than 0.8 W/kg and the conducted power is within ±0.5 dB, the remaining channels are reduced per KDB941225 D05 page 4 footnote 2.

Band/ Frequency (MHz)	Side	Required Test Channel	Bandwidth	Modulation	RB Allocation	RB Offset	Tested/ Reduced
Band 66 1710-1780 MHz	E	132072	20 MHz	QPSK	50	25	Reduced ⁶
		132322					Tested
		132572					Reduced ⁶
		132072			100	0	Reduced ¹
		132322					Reduced ¹
		132572					Reduced ¹
		132072			1	49	Tested
		132322					Tested
		132572					Tested
		132072					99
		132322		Reduced ²			
		132572		Reduced ²			
		132072		16QAM	50	25	Reduced ³
		132322					Reduced ³
		132572					Reduced ³
		132072			100	0	Reduced ¹
		132322					Reduced ¹
		132572					Reduced ¹
		132072			1	49	Reduced ⁴
		132322					Reduced ⁴
132572	Reduced ⁴						
132072	99	Reduced ⁴					
132322		Reduced ⁴					
132572		Reduced ⁴					
All lower bandwidths (15 MHz, 10 MHz, 5 MHz, 3 MHz, 1.4 MHz)							Reduced ⁵

Reduced¹ – If the SAR value in the 50% RB testing is less than 1.45 W/kg, the 100% RB testing is reduced per KDB941225 D05 3) A) I) page 4.

Reduced² - If the SAR value in the 1 RB testing is less than 1.45 W/kg, the remaining channels are reduced per KDB941225 D05 3) B) I) page 4.

Reduced³ - If the SAR value in the 50% RB testing is less than 1.45 W/kg, the remaining channels are reduced per KDB941225 D05 4) A) I) page 4.

Reduced⁴- If the SAR value in the 1 RB testing is less than 1.45 W/kg, the remaining channels are reduced per KDB941225 D05 4) B) I) page 5.

Reduced⁵- If the conducted power is within ±0.5 dB, all testing where the SAR value is less than 1.45 W/kg is reduced per KDB941225 D05 5) B) I) page 5.

Reduced⁶- If the SAR value measured on the middle channel is less than 0.8 W/kg and the conducted power is within ±0.5 dB, the remaining channels are reduced per KDB941225 D05 page 4 footnote 2.

Side F Reduced based on distance in KDB 447498 D01 v06 (See below calculations).

Maximum power: 251.2 mW
Closest Distance to Side F: 97 mm

$$[{\{(3.0)/(\sqrt{1.755})\} * 50 \text{ mm}}] + \{97 - 50 \text{ mm}\} * 10 = 583 \text{ mW which is greater than 251.2 mW}$$

Band/ Frequency (MHz)	Side	Required Test Channel	Bandwidth	Modulation	RB Allocation	RB Offset	Tested/ Reduced	
Band 5 824-849 MHz	A	20450	10 MHz	QPSK	25	12	Reduced ⁶	
		20525					Tested	
		20600			50	0	Reduced ⁶	
		20450					Reduced ¹	
		20525			1	24	Reduced ¹	
		20600					Reduced ⁶	
		20450			49	24	Tested	
		20525					Reduced ⁶	
		20600			1	49	Reduced ²	
		20450					Reduced ²	
		20525		25	12	Reduced ²		
		20600				Reduced ³		
		20450		50	0	Reduced ³		
		20525				Reduced ³		
		20600		1	24	Reduced ¹		
		20450				Reduced ¹		
		20525		49	24	Reduced ¹		
		20600				Reduced ⁴		
		20450		1	49	Reduced ⁴		
		20525				Reduced ⁴		
	20600	All lower bandwidths (5 MHz)		Reduced ⁴				
								Reduced ⁵
	B	QPSK	20450	10 MHz	25	12	Reduced ⁶	
			20525				Tested	
			20600		50	0	Reduced ⁶	
			20450				Reduced ¹	
			20525		1	24	Reduced ¹	
			20600				Reduced ⁶	
			20450		49	24	Tested	
			20525				Reduced ⁶	
			20600		1	49	Reduced ²	
			20450				Reduced ²	
		20525	25	12	Reduced ²			
		20600			Reduced ³			
		20450	50	0	Reduced ³			
		20525			Reduced ³			
		20600	1	24	Reduced ¹			
		20450			Reduced ¹			
		20525	49	24	Reduced ¹			
		20600			Reduced ⁴			
		20450	1	49	Reduced ⁴			
		20525			Reduced ⁴			
		20600	All lower bandwidths (5 MHz)		Reduced ⁴			

Reduced¹ – If the SAR value in the 50% RB testing is less than 1.45 W/kg, the 100% RB testing is reduced per KDB941225 D05 3) A) I) page 4.
 Reduced² - If the SAR value in the 1 RB testing is less than 1.45 W/kg, the remaining channels are reduced per KDB941225 D05 3) B) I) page 4.
 Reduced³ - If the SAR value in the 50% RB testing is less than 1.45 W/kg, the remaining channels are reduced per KDB941225 D05 4) A) I) page 4.
 Reduced⁴ - If the SAR value in the 1 RB testing is less than 1.45 W/kg, the remaining channels are reduced per KDB941225 D05 4) B) I) page 5.
 Reduced⁵ - If the conducted power is within ±0.5 dB, all testing where the SAR value is less than 1.45 W/kg is reduced per KDB941225 D05 5) B) I) page 5.
 Reduced⁶ - If the SAR value measured on the middle channel is less than 0.8 W/kg and the conducted power is within ±0.5 dB, the remaining channels are reduced per KDB941225 D05 page 4 footnote 2.

Band/ Frequency (MHz)	Side	Required Test Channel	Bandwidth	Modulation	RB Allocation	RB Offset	Tested/ Reduced			
Band 5 824-849 MHz	C	20450	10 MHz	QPSK	25	12	Reduced ⁶			
		20525					Tested			
		20600			50	0	Reduced ⁶			
		20450					Reduced ¹			
		20525			1	24	Reduced ¹			
		20600					Reduced ⁶			
		20450			49	24	Tested			
		20525					Reduced ⁶			
		20600			25	12	Reduced ²			
		20450					Reduced ²			
		20525		50	0	Reduced ²				
		20600				Reduced ²				
		20450		1	24	Reduced ³				
		20525				Reduced ³				
		20600		50	0	Reduced ³				
		20450				Reduced ¹				
		20525		1	49	Reduced ¹				
		20600				Reduced ¹				
		All lower bandwidths (5 MHz)							Reduced ⁴	
		All lower bandwidths (5 MHz)							Reduced ⁵	
	D	QPSK	20450	10 MHz	25	12	Reduced ⁶			
			20525				Tested			
			20600		50	0	Reduced ⁶			
			20450				Reduced ¹			
			20525		1	12	Reduced ¹			
			20600				Reduced ¹			
			20450		24	12	Reduced ⁶			
			20525				Tested			
			20600		50	0	Reduced ⁶			
			20450				Reduced ²			
		20525	1	24	Reduced ²					
		20600			Reduced ²					
		20450	25	12	Reduced ²					
		20525			Reduced ³					
		20600	50	0	Reduced ³					
		20450			Reduced ³					
		20525	1	24	Reduced ¹					
		20600			Reduced ¹					
		20450	49	24	Reduced ¹					
		20525			Reduced ⁴					
	20600	1	49	Reduced ⁴						
	20450			Reduced ⁴						
	All lower bandwidths (5 MHz)							Reduced ⁴		
	All lower bandwidths (5 MHz)							Reduced ⁵		

Reduced¹ – If the SAR value in the 50% RB testing is less than 1.45 W/kg, the 100% RB testing is reduced per KDB941225 D05 3) A) I) page 4.
 Reduced² - If the SAR value in the 1 RB testing is less than 1.45 W/kg, the remaining channels are reduced per KDB941225 D05 3) B) I) page 4.
 Reduced³ - If the SAR value in the 50% RB testing is less than 1.45 W/kg, the remaining channels are reduced per KDB941225 D05 4) A) I) page 4.
 Reduced⁴ - If the SAR value in the 1 RB testing is less than 1.45 W/kg, the remaining channels are reduced per KDB941225 D05 4) B) I) page 5.
 Reduced⁵ - If the conducted power is within ±0.5 dB, all testing where the SAR value is less than 1.45 W/kg is reduced per KDB941225 D05 5) B) I) page 5.
 Reduced⁶ - If the SAR value measured on the middle channel is less than 0.8 W/kg and the conducted power is within ±0.5 dB, the remaining channels are reduced per KDB941225 D05 page 4 footnote 2.

Band/ Frequency (MHz)	Side	Required Test Channel	Bandwidth	Modulation	RB Allocation	RB Offset	Tested/ Reduced		
Band 5 824-849 MHz	E	20450	10 MHz	QPSK	25	12	Reduced ⁶		
		20525					Tested		
		20600					Reduced ⁶		
		20450					50	0	Reduced ¹
		20525							Reduced ¹
		20600							Reduced ¹
		20450			1	12	Reduced ⁶		
		20525					Tested		
		20600					Reduced ⁶		
		20450			1	24	Reduced ²		
		20525					Reduced ²		
		20600					Reduced ²		
		20450		25	12	Reduced ³			
		20525				Reduced ³			
		20600				Reduced ³			
		20450		50	0	Reduced ¹			
		20525				Reduced ¹			
		20600				Reduced ¹			
		20450		1	24	Reduced ⁴			
		20525				Reduced ⁴			
		20600				Reduced ⁴			
20450	1	49	Reduced ⁴						
20525			Reduced ⁴						
20600			Reduced ⁴						
All lower bandwidths (5 MHz)							Reduced ⁵		

- Reduced¹ – If the SAR value in the 50% RB testing is less than 1.45 W/kg, the 100% RB testing is reduced per KDB941225 D05 3) A) I) page 4.
- Reduced² - If the SAR value in the 1 RB testing is less than 1.45 W/kg, the remaining channels are reduced per KDB941225 D05 3) B) I) page 4.
- Reduced³ - If the SAR value in the 50% RB testing is less than 1.45 W/kg, the remaining channels are reduced per KDB941225 D05 4) A) I) page 4.
- Reduced⁴- If the SAR value in the 1 RB testing is less than 1.45 W/kg, the remaining channels are reduced per KDB941225 D05 4) B) I) page 5.
- Reduced⁵- If the conducted power is within ±0.5 dB, all testing where the SAR value is less than 1.45 W/kg is reduced per KDB941225 D05 5) B) I) page 5.
- Reduced⁶- If the SAR value measured on the middle channel is less than 0.8 W/kg and the conducted power is within ±0.5 dB, the remaining channels are reduced per KDB941225 D05 page 4 footnote 2.

Side F Reduced based on distance in KDB 447498 D01 v06 (See below calculations).

Maximum power: 251.2 mW
 Closest Distance to Side F: 97 mm

$$[{\frac{3.0}{\sqrt{0.849}}}] * 50 \text{ mm}] + [(97 - 50 \text{ mm}) * 10] = 632 \text{ mW which is greater than } 251.2 \text{ mW}$$

Band/ Frequency (MHz)	Side	Required Test Channel	Bandwidth	Modulation	RB Allocation	RB Offset	Tested/ Reduced	
Band 13 777-787 MHz	A	23230	10 MHz	QPSK	25	12	Tested	
		23230			50	0	Tested	
		23230			1	24	Tested	
		23230				49	Reduced ²	
		23230		16QAM	25	12	Reduced ³	
		23230			50	0	Reduced ¹	
		23230			1	24	Reduced ⁴	
		23230				49	Reduced ⁴	
	All lower bandwidths (5 MHz)							Reduced ⁵
	B	10 MHz	23230	QPSK	25	12	Tested	
			23230		50	0	Reduced ¹	
			23230		1	24	Tested	
			23230			49	Reduced ²	
			23230	16QAM	25	12	Reduced ³	
			23230		50	0	Reduced ¹	
			23230		1	24	Reduced ⁴	
			23230			49	Reduced ⁴	
	All lower bandwidths (5 MHz)							Reduced ⁵

Reduced¹ – If the SAR value in the 50% RB testing is less than 1.45 W/kg, the 100% RB testing is reduced per KDB941225 D05 3)

A) I) page 4.

Reduced² - If the SAR value in the 1 RB testing is less than 1.45 W/kg, the remaining channels are reduced per KDB941225 D05 3)

B) I) page 4.

Reduced³ - If the SAR value in the 50% RB testing is less than 1.45 W/kg, the remaining channels are reduced per KDB941225 D05

4) A) I) page 4.

Reduced⁴- If the SAR value in the 1 RB testing is less than 1.45 W/kg, the remaining channels are reduced per KDB941225 D05 4)

B) I) page 5.

Reduced⁵- If the conducted power is within ± 0.5 dB, all testing where the SAR value is less than 1.45 W/kg is reduced per

KDB941225 D05 5) B) I) page 5.

Reduced⁶- If the SAR value measured on the middle channel is less than 0.8 W/kg and the conducted power is within ± 0.5 dB, the

remaining channels are reduced per KDB941225 D05 page 4 footnote 2.

Band/ Frequency (MHz)	Side	Required Test Channel	Bandwidth	Modulation	RB Allocation	RB Offset	Tested/ Reduced	
Band 13 777-787 MHz	C	23230	10 MHz	QPSK	25	12	Tested	
		23230			50	0	Reduced ¹	
		23230			1	24	Tested	
		23230		16QAM	25	12	Reduced ³	
		23230			50	0	Reduced ¹	
		23230			1	24	Reduced ⁴	
		23230			1	49	Reduced ⁴	
	All lower bandwidths (5 MHz)							Reduced ⁵
	D	23230	10 MHz	QPSK	25	12	Tested	
		23230			50	0	Reduced ¹	
		23230			1	24	Tested	
		23230		16QAM	25	12	Reduced ³	
		23230			50	0	Reduced ¹	
		23230			1	24	Reduced ⁴	
		23230			1	49	Reduced ⁴	
	All lower bandwidths (5 MHz)							Reduced ⁵

Reduced¹ – If the SAR value in the 50% RB testing is less than 1.45 W/kg, the 100% RB testing is reduced per KDB941225 D05 3)

A) I) page 4.

Reduced² - If the SAR value in the 1 RB testing is less than 1.45 W/kg, the remaining channels are reduced per KDB941225 D05 3)

B) I) page 4.

Reduced³ - If the SAR value in the 50% RB testing is less than 1.45 W/kg, the remaining channels are reduced per KDB941225 D05

4) A) I) page 4.

Reduced⁴- If the SAR value in the 1 RB testing is less than 1.45 W/kg, the remaining channels are reduced per KDB941225 D05 4)

B) I) page 5.

Reduced⁵- If the conducted power is within ± 0.5 dB, all testing where the SAR value is less than 1.45 W/kg is reduced per

KDB941225 D05 5) B) I) page 5.

Reduced⁶- If the SAR value measured on the middle channel is less than 0.8 W/kg and the conducted power is within ± 0.5 dB, the

remaining channels are reduced per KDB941225 D05 page 4 footnote 2.

Band/ Frequency (MHz)	Side	Required Test Channel	Bandwidth	Modulation	RB Allocation	RB Offset	Tested/ Reduced	
Band 13 777-787 MHz	E	23230	10 MHz	QPSK	25	12	Tested	
		23230			50	0	Reduced ¹	
		23230			1	24	Tested	
		23230					49	Reduced ²
		23230		16QAM	25	12	Reduced ³	
		23230			50	0	Reduced ¹	
		23230			1	24	Reduced ⁴	
		23230				49	Reduced ⁴	
		All lower bandwidths (5 MHz)						

Reduced¹ – If the SAR value in the 50% RB testing is less than 1.45 W/kg, the 100% RB testing is reduced per KDB941225 D05 3) A) I) page 4.

Reduced² - If the SAR value in the 1 RB testing is less than 1.45 W/kg, the remaining channels are reduced per KDB941225 D05 3) B) I) page 4.

Reduced³ - If the SAR value in the 50% RB testing is less than 1.45 W/kg, the remaining channels are reduced per KDB941225 D05 4) A) I) page 4.

Reduced⁴- If the SAR value in the 1 RB testing is less than 1.45 W/kg, the remaining channels are reduced per KDB941225 D05 4) B) I) page 5.

Reduced⁵- If the conducted power is within ±0.5 dB, all testing where the SAR value is less than 1.45 W/kg is reduced per KDB941225 D05 5) B) I) page 5.

Reduced⁶- If the SAR value measured on the middle channel is less than 0.8 W/kg and the conducted power is within ±0.5 dB, the remaining channels are reduced per KDB941225 D05 page 4 footnote 2.

Side F Reduced based on distance in KDB 447498 D01 v06 (See below calculations).

Maximum power: 251.2 mW

Closest Distance to Side F: 97 mm

$[\{(3.0)/(\sqrt{0.782})\} * 50 \text{ mm}] + \{(97 - 50 \text{ mm}) * 10\} = 639 \text{ mW}$ which is greater than 251.2 mW

Band/ Frequency (MHz)	Side	Required Test Channel	Bandwidth	Modulation	RB Allocation	RB Offset	Tested/ Reduced
Band 48 3550-3700 MHz	A	55340	20 MHz	QPSK	50	25	Reduced ⁶
		55665					Reduced ⁶
		55990					Tested
		56315					Reduced ⁶
		56640					Reduced ⁶
		55340					Reduced ¹
		55665			Reduced ¹		
		55990			Reduced ¹		
		56315			Reduced ¹		
		56640			Reduced ¹		
		55340			Reduced ⁶		
		55665			Reduced ⁶		
		55990			49	Tested	
		56315			Reduced ⁶		
		56640			Reduced ⁶		
		55340			Reduced ²		
		55665			Reduced ²		
		55990			99	Reduced ²	
		56315		Reduced ²			
		56640		Reduced ²			
		55340		Reduced ³			
		55665		Reduced ³			
		55990		50	Reduced ³		
		56315		Reduced ³			
		56640		Reduced ³			
		55340		Reduced ¹			
		55665		Reduced ¹			
		55990		100	Reduced ¹		
		56315		Reduced ¹			
		56640		Reduced ¹			
		55340		Reduced ⁴			
		55665		Reduced ⁴			
		55990		49	Reduced ⁴		
		56315		Reduced ⁴			
		56640		Reduced ⁴			
		55340		Reduced ⁴			
55665	Reduced ⁴						
55990	99	Reduced ⁴					
56315	Reduced ⁴						
56640	Reduced ⁴						
All lower bandwidths (15 MHz, 10 MHz, 5 MHz, 3 MHz, 1.4 MHz)							Reduced ⁵

Reduced¹ – If the SAR value in the 50% RB testing is less than 1.45 W/kg, the 100% RB testing is reduced per KDB941225 D05 3) A) I) page 4.
 Reduced² - If the SAR value in the 1 RB testing is less than 1.45 W/kg, the remaining channels are reduced per KDB941225 D05 3) B) I) page 4.
 Reduced³ - If the SAR value in the 50% RB testing is less than 1.45 W/kg, the remaining channels are reduced per KDB941225 D05 4) A) I) page 4.
 Reduced⁴- If the SAR value in the 1 RB testing is less than 1.45 W/kg, the remaining channels are reduced per KDB941225 D05 4) B) I) page 5.
 Reduced⁵- If the conducted power is within ±0.5 dB, all testing where the SAR value is less than 1.45 W/kg is reduced per KDB941225 D05 5) B) I) page 5.
 Reduced⁶- If the SAR value measured on the middle channel is less than 0.8 W/kg and the conducted power is within ±0.5 dB, the remaining channels are reduced per KDB941225 D05 page 4 footnote 2.

Band/ Frequency (MHz)	Side	Required Test Channel	Bandwidth	Modulation	RB Allocation	RB Offset	Tested/ Reduced
Band 48 3550-3700 MHz	C	55340	20 MHz	QPSK	50	25	Reduced ⁶
		55665					Reduced ⁶
		55990					Tested
		56315					Reduced ⁶
		56640					Reduced ⁶
		55340					Reduced ¹
		55665			Reduced ¹		
		55990			Reduced ¹		
		56315			Reduced ¹		
		56640			Reduced ¹		
		55340			100	0	Reduced ¹
		55665					Reduced ¹
		55990					Reduced ¹
		56315					Reduced ¹
		56640					Reduced ¹
		55340					1
		55665			Reduced ⁶		
		55990			Tested		
		56315		Reduced ⁶			
		56640		Reduced ⁶			
		55340		99	99	Reduced ²	
		55665				Reduced ²	
		55990				Reduced ²	
		56315				Reduced ²	
		56640				Reduced ²	
		55340				50	25
		55665		Reduced ³			
		55990		Reduced ³			
		56315		Reduced ³			
		56640		Reduced ³			
		55340		100	0		
		55665				Reduced ¹	
		55990				Reduced ¹	
		56315				Reduced ¹	
		56640				Reduced ¹	
		55340				1	49
55665	Reduced ⁴						
55990	Reduced ⁴						
56315	Reduced ⁴						
56640	Reduced ⁴						
55340	99	99	Reduced ⁴				
55665			Reduced ⁴				
55990			Reduced ⁴				
56315			Reduced ⁴				
56640			Reduced ⁴				
56640			All lower bandwidths (15 MHz, 10 MHz, 5 MHz, 3 MHz, 1.4 MHz)				

Reduced¹ – If the SAR value in the 50% RB testing is less than 1.45 W/kg, the 100% RB testing is reduced per KDB941225 D05 3) A) I) page 4.
 Reduced² - If the SAR value in the 1 RB testing is less than 1.45 W/kg, the remaining channels are reduced per KDB941225 D05 3) B) I) page 4.
 Reduced³ - If the SAR value in the 50% RB testing is less than 1.45 W/kg, the remaining channels are reduced per KDB941225 D05 4) A) I) page 4.
 Reduced⁴- If the SAR value in the 1 RB testing is less than 1.45 W/kg, the remaining channels are reduced per KDB941225 D05 4) B) I) page 5.
 Reduced⁵- If the conducted power is within ±0.5 dB, all testing where the SAR value is less than 1.45 W/kg is reduced per KDB941225 D05 5) B) I) page 5.
 Reduced⁶- If the SAR value measured on the middle channel is less than 0.8 W/kg and the conducted power is within ±0.5 dB, the remaining channels are reduced per KDB941225 D05 page 4 footnote 2.

Band/ Frequency (MHz)	Side	Required Test Channel	Bandwidth	Modulation	RB Allocation	RB Offset	Tested/ Reduced	
Band 48 3550-3700 MHz	D	55340	20 MHz	QPSK	50	25	Reduced ⁶	
		55665					Reduced ⁶	
		55990					Tested	
		56315					Reduced ⁶	
		56640					Reduced ⁶	
		55340			100	0	Reduced ¹	
		55665					Reduced ¹	
		55990					Reduced ¹	
		56315					Reduced ¹	
		56640					Reduced ¹	
		55340			1	49	Reduced ⁶	
		55665					Reduced ⁶	
		55990					Tested	
		56315					Reduced ⁶	
		56640					Reduced ⁶	
		55340				99	99	Reduced ²
		55665						Reduced ²
		55990						Reduced ²
		56315						Reduced ²
		56640						Reduced ²
		55340		50	25	Reduced ³		
		55665				Reduced ³		
		55990				Reduced ³		
		56315				Reduced ³		
		56640				Reduced ³		
		55340			100	0	Reduced ¹	
		55665					Reduced ¹	
		55990					Reduced ¹	
		56315					Reduced ¹	
		56640					Reduced ¹	
		55340		1	49	Reduced ⁴		
		55665				Reduced ⁴		
		55990				Reduced ⁴		
		56315				Reduced ⁴		
		56640				Reduced ⁴		
		55340			99	99	Reduced ⁴	
		55665					Reduced ⁴	
		55990					Reduced ⁴	
		56315					Reduced ⁴	
		56640					Reduced ⁴	
All lower bandwidths (15 MHz, 10 MHz, 5 MHz, 3 MHz, 1.4 MHz)							Reduced ⁵	

Reduced¹ – If the SAR value in the 50% RB testing is less than 1.45 W/kg, the 100% RB testing is reduced per KDB941225 D05 3) A) I) page 4.

Reduced² - If the SAR value in the 1 RB testing is less than 1.45 W/kg, the remaining channels are reduced per KDB941225 D05 3) B) I) page 4.

Reduced³ - If the SAR value in the 50% RB testing is less than 1.45 W/kg, the remaining channels are reduced per KDB941225 D05 4) A) I) page 4.

Reduced⁴- If the SAR value in the 1 RB testing is less than 1.45 W/kg, the remaining channels are reduced per KDB941225 D05 4) B) I) page 5.

Reduced⁵- If the conducted power is within ±0.5 dB, all testing where the SAR value is less than 1.45 W/kg is reduced per KDB941225 D05 5) B) I) page 5.

Reduced⁶- If the SAR value measured on the middle channel is less than 0.8 W/kg and the conducted power is within ±0.5 dB, the remaining channels are reduced per KDB941225 D05 page 4 footnote 2.

Band/ Frequency (MHz)	Side	Required Test Channel	Bandwidth	Modulation	RB Allocation	RB Offset	Tested/ Reduced
Band 48 3550-3700 MHz	E	55340	20 MHz	QPSK	50	25	Reduced ⁶
		55665					Reduced ⁶
		55990					Tested
		56315					Reduced ⁶
		56640					Reduced ⁶
		55340					Reduced ¹
		55665			Reduced ¹		
		55990			Reduced ¹		
		56315			Reduced ¹		
		56640			Reduced ¹		
		55340			100	0	Reduced ¹
		55665					Reduced ¹
		55990					Reduced ¹
		56315					Reduced ¹
		56640					Reduced ¹
		55340					1
		55665			Reduced ⁶		
		55990			Tested		
		56315		Reduced ⁶			
		56640		Reduced ⁶			
		55340		99	99	Reduced ²	
		55665				Reduced ²	
		55990				Reduced ²	
		56315				Reduced ²	
		56640				Reduced ²	
		55340				50	25
		55665		Reduced ³			
		55990		Reduced ³			
		56315		Reduced ³			
		56640		Reduced ³			
		55340		100	0		
		55665				Reduced ¹	
		55990				Reduced ¹	
		56315				Reduced ¹	
		56640				Reduced ¹	
		55340				1	49
55665	Reduced ⁴						
55990	Reduced ⁴						
56315	Reduced ⁴						
56640	Reduced ⁴						
55340	99	99	Reduced ⁴				
55665			Reduced ⁴				
55990			Reduced ⁴				
56315			Reduced ⁴				
56640			Reduced ⁴				
56640			Reduced ⁴				
All lower bandwidths (15 MHz, 10 MHz, 5 MHz, 3 MHz, 1.4 MHz)							Reduced ⁵

Reduced¹ - If the SAR value in the 50% RB testing is less than 1.45 W/kg, the 100% RB testing is reduced per KDB941225 D05 3) A) I) page 4.

Reduced² - If the SAR value in the 1 RB testing is less than 1.45 W/kg, the remaining channels are reduced per KDB941225 D05 3) B) I) page 4.

Reduced³ - If the SAR value in the 50% RB testing is less than 1.45 W/kg, the remaining channels are reduced per KDB941225 D05 4) A) I) page 4.

Reduced⁴ - If the SAR value in the 1 RB testing is less than 1.45 W/kg, the remaining channels are reduced per KDB941225 D05 4) B) I) page 5.

Reduced⁵ - If the conducted power is within ±0.5 dB, all testing where the SAR value is less than 1.45 W/kg is reduced per KDB941225 D05 5) B) I) page 5.

Reduced⁶ - If the SAR value measured on the middle channel is less than 0.8 W/kg and the conducted power is within ±0.5 dB, the remaining channels are reduced per KDB941225 D05 page 4 footnote 2.

Sides B & F Reduced based on distance in KDB 447498 D01 v06 (See below calculations).

Maximum power: 251.2 mW
 Closest Distance to Side B: 78 mm
 Closest Distance to Side F: 97 mm

Side B is the closest; therefore, if Side B is excluded side F would also be excluded.

$$[[{(3.0)/(\sqrt{3.70})]*50 \text{ mm}}]+[(78-50 \text{ mm})*10]=357 \text{ mW}$$

which is greater than 251.2 mW

SAR Data Summary – 750 MHz Body – LTE Band 13

MEASUREMENT RESULTS											
Gap	Plot	Position	Frequency		BW/ Modulation	RB Size	RB Offset	MPR Target	End Power (dBm)	Measured SAR (W/kg)	Reported SAR (W/kg)
			MHz	Ch.							
10 mm	1	Side A	782.0	23230	10 MHz/QPSK	1	25	0	23.98	0.890	0.89
	-----		782.0	23230	10 MHz/QPSK	25	13	1	22.94	0.767	0.78
	-----		782.0	23230	10 MHz/QPSK	50	0	1	22.88	0.651	0.67
	-----	Side B	782.0	23230	10 MHz/QPSK	1	25	0	23.98	0.543	0.55
	-----		782.0	23230	10 MHz/QPSK	25	13	1	22.94	0.439	0.45
	-----	Side C	782.0	23230	10 MHz/QPSK	1	25	0	23.98	0.795	0.80
	-----		782.0	23230	10 MHz/QPSK	25	13	1	22.94	0.643	0.65
	-----	Side D	782.0	23230	10 MHz/QPSK	1	25	0	23.98	0.257	0.26
	-----		782.0	23230	10 MHz/QPSK	25	13	1	22.94	0.199	0.20
	-----	Side E	782.0	23230	10 MHz/QPSK	1	25	0	23.98	0.172	0.17
	-----		782.0	23230	10 MHz/QPSK	25	13	1	22.94	0.121	0.12
	-----	Repeat	782.0	23230	10 MHz/QPSK	1	25	0	23.98	0.876	0.88

Body
1.6 W/kg (mW/g)
 averaged over 1 gram

1. Battery is fully charged for all tests.
 Power Measured Conducted ERP EIRP
2. SAR Measurement
 Phantom Configuration Left Head Eli4 Right Head
 SAR Configuration Head Body
3. Test Signal Call Mode Test Code Base Station Simulator
4. Test Configuration With Belt Clip Without Belt Clip N/A
5. Tissue Depth is at least 15.0 cm

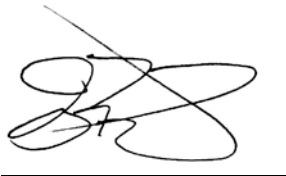

Jay M. Moulton
Vice President

SAR Data Summary – 835 MHz Body - WCDMA

MEASUREMENT RESULTS

Gap	Plot	Frequency		Modulation	Position	End Power (dBm)	RMC	Test Set Up	Measured SAR (W/kg)	Reported SAR (W/kg)
		MHz	Ch.							
10 mm	----	826.4	4132	WCDMA	Side A	23.70	12.2 kbps	Test Loop 1	0.685	0.73
	2	836.6	4183	WCDMA		24.00	12.2 kbps	Test Loop 1	0.817	0.82
	----	846.4	4233	WCDMA		23.70	12.2 kbps	Test Loop 1	0.685	0.73
	----	836.6	4183	WCDMA	Side B	24.00	12.2 kbps	Test Loop 1	0.445	0.45
	----	836.6	4183	WCDMA	Side C	24.00	12.2 kbps	Test Loop 1	0.720	0.72
	----	836.6	4183	WCDMA	Side D	24.00	12.2 kbps	Test Loop 1	0.309	0.31
	----	836.6	4183	WCDMA	Side E	24.00	12.2 kbps	Test Loop 1	0.164	0.16
	----	836.6	4183	WCDMA	Repeat	24.00	12.2 kbps	Test Loop 1	0.798	0.80

Body
1.6 W/kg (mW/g)
 averaged over 1 gram

1. Battery is fully charged for all tests.
 Power Measured Conducted ERP EIRP
2. SAR Measurement
 Phantom Configuration Left Head Eli4 Right Head
 SAR Configuration Head Body
3. Test Signal Call Mode Test Code Base Station Simulator
4. Test Configuration With Belt Clip Without Belt Clip N/A
5. Tissue Depth is at least 15.0 cm

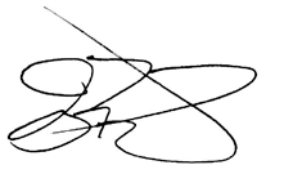

Jay M. Moulton
 Vice President

SAR Data Summary – 835 MHz Body – LTE Band 5

MEASUREMENT RESULTS											
Gap	Plot	Position	Frequency		BW/ Modulation	RB Size	RB Offset	MPR Target	End Power (dBm)	Measured SAR (W/kg)	Reported SAR (W/kg)
			MHz	Ch.							
10 mm	3	Side A	836.5	20525	10 MHz/QPSK	1	25	0	23.95	0.623	0.63
	-----		836.5	20525	10 MHz/QPSK	25	13	1	22.87	0.494	0.51
	-----	Side B	836.5	20525	10 MHz/QPSK	1	25	0	23.95	0.344	0.35
	-----		836.5	20525	10 MHz/QPSK	25	13	1	22.87	0.283	0.29
	-----	Side C	836.5	20525	10 MHz/QPSK	1	25	0	23.95	0.437	0.44
	-----		836.5	20525	10 MHz/QPSK	25	13	1	22.87	0.338	0.35
	-----	Side D	836.5	20525	10 MHz/QPSK	1	25	0	23.95	0.227	0.23
	-----		836.5	20525	10 MHz/QPSK	25	13	1	22.87	0.186	0.19
	-----	Side E	836.5	20525	10 MHz/QPSK	1	25	0	23.95	0.247	0.25
	-----		836.5	20525	10 MHz/QPSK	25	13	1	22.87	0.171	0.18

Body
1.6 W/kg (mW/g)
 averaged over 1 gram

1. Battery is fully charged for all tests.
 Power Measured Conducted ERP EIRP
2. SAR Measurement
 Phantom Configuration Left Head Eli4 Right Head
 SAR Configuration Head Body
3. Test Signal Call Mode Test Code Base Station Simulator
4. Test Configuration With Belt Clip Without Belt Clip N/A
5. Tissue Depth is at least 15.0 cm

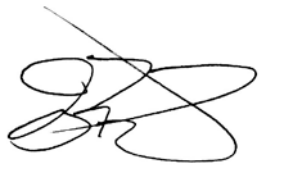

Jay M. Moulton
 Vice President

SAR Data Summary – 1750 MHz Body - WCDMA

MEASUREMENT RESULTS

Gap	Plot	Frequency		Rev Level/ Modulation	Position	End Power (dBm)	RMC	Test Set Up	Measured SAR (W/kg)	Reported SAR (W/kg)
		MHz	Ch.							
10 mm	----	1712.4	1312	WCDMA	Side A	23.83	12.2 kbps	Test Loop 1	0.733	0.76
	----	1732.6	1413	WCDMA		23.91	12.2 kbps	Test Loop 1	0.933	0.95
	4	1752.6	1513	WCDMA		23.97	12.2 kbps	Test Loop 1	1.17	1.18
	----	1732.6	1413	WCDMA	Side B	23.91	12.2 kbps	Test Loop 1	0.426	0.44
	----	1732.6	1413	WCDMA	Side C	23.91	12.2 kbps	Test Loop 1	0.355	0.36
	----	1732.6	1413	WCDMA	Side D	23.91	12.2 kbps	Test Loop 1	0.107	0.11
	----	1732.6	1413	WCDMA	Side E	23.91	12.2 kbps	Test Loop 1	0.517	0.53
	----	1752.6	1513	WCDMA	Repeat	23.91	12.2 kbps	Test Loop 1	1.15	1.17

Body
1.6 W/kg (mW/g)
 averaged over 1 gram

1. Battery is fully charged for all tests.
 Power Measured Conducted ERP EIRP
2. SAR Measurement
 Phantom Configuration Left Head Eli4 Right Head
 SAR Configuration Head Body
3. Test Signal Call Mode Test Code Base Station Simulator
4. Test Configuration With Belt Clip Without Belt Clip N/A
5. Tissue Depth is at least 15.0 cm



Jay M. Moulton
 Vice President

SAR Data Summary – 1750 MHz Body – LTE Band 66

MEASUREMENT RESULTS

Gap	Plot	Position	Frequency		BW/ Modulation	RB Size	RB Offset	MPR Target	End Power (dBm)	Measured SAR (W/kg)	Reported SAR (W/kg)
			MHz	Ch.							
10 mm	-----	Side A	1720.0	132072	20 MHz/QPSK	1	49	0	23.00	0.852	0.85
	-----		1745.0	132322	20 MHz/QPSK	1	49	0	23.00	0.847	0.85
	5		1780.0	132572	20 MHz/QPSK	1	49	0	22.57	0.861	0.95
	-----		1745.0	132322	20 MHz/QPSK	50	25	1	22.37	0.712	0.82
	-----		1780.0	132572	20 MHz/QPSK	100	0	1	22.51	0.633	0.71
	-----	Side B	1745.0	132322	20 MHz/QPSK	1	49	0	23.00	0.364	0.36
	-----		1745.0	132322	20 MHz/QPSK	50	25	1	22.37	0.278	0.32
	-----	Side C	1745.0	132322	20 MHz/QPSK	1	49	0	23.00	0.349	0.35
	-----		1745.0	132322	20 MHz/QPSK	50	25	1	22.37	0.270	0.31
	-----	Side D	1745.0	132322	20 MHz/QPSK	1	49	0	23.00	0.0799	0.08
	-----		1745.0	132322	20 MHz/QPSK	50	25	1	22.37	0.0618	0.07
	-----	Side E	1720.0	132072	20 MHz/QPSK	1	49	0	23.00	0.675	0.68
	-----		1745.0	132322	20 MHz/QPSK	1	49	0	23.00	0.722	0.72
	-----		1780.0	132572	20 MHz/QPSK	1	49	0	22.57	0.697	0.77
	-----		1745.0	132322	20 MHz/QPSK	50	25	1	22.37	0.780	0.90
	-----	Repeat	1720.0	132072	20 MHz/QPSK	1	49	0	22.57	0.849	0.94

Body
1.6 W/kg (mW/g)
averaged over 1 gram

- Battery is fully charged for all tests.
Power Measured Conducted ERP EIRP
- SAR Measurement
Phantom Configuration Left Head Eli4 Right Head
SAR Configuration Head Body
- Test Signal Call Mode Test Code Base Station Simulator
- Test Configuration With Belt Clip Without Belt Clip N/A
- Tissue Depth is at least 15.0 cm



Jay M. Moulton
Vice President

Note: Band 4 LTE is fully within the frequency band of B66. Therefore, Band 4 was not tested for standalone SAR. The highest value in B66 was tested in Band 4 for uplink carrier aggregation evaluation.

SAR Data Summary – 1900 MHz Body - WCDMA

MEASUREMENT RESULTS

Gap	Plot	Frequency		Rev Level/ Modulation	Position	End Power (dBm)	RMC	Test Set Up	Measured SAR (W/kg)	Reported SAR (W/kg)
		MHz	Ch.							
10 mm	----	1852.4	9262	WCDMA	Side A	23.60	12.2 kbps	Test Loop 1	0.987	1.08
	----	1880.0	9400	WCDMA		23.70	12.2 kbps	Test Loop 1	1.01	1.08
	6	1907.6	9538	WCDMA		23.40	12.2 kbps	Test Loop 1	1.03	1.18
	----	1852.4	9262	WCDMA	Side B	23.70	12.2 kbps	Test Loop 1	0.669	0.72
	----	1880.0	9400	WCDMA	Side C	23.70	12.2 kbps	Test Loop 1	0.651	0.70
	----	1852.4	9262	WCDMA	Side D	23.70	12.2 kbps	Test Loop 1	0.0375	0.04
	----	1852.4	9262	WCDMA	Side E	23.70	12.2 kbps	Test Loop 1	0.609	0.65
	----	1907.6	9538	WCDMA	Repeat	23.40	12.2 kbps	Test Loop 1	1.01	1.16

Body
1.6 W/kg (mW/g)
 averaged over 1 gram

1. Battery is fully charged for all tests.
 Power Measured Conducted ERP EIRP
2. SAR Measurement
 Phantom Configuration Left Head Eli4 Right Head
 SAR Configuration Head Body
3. Test Signal Call Mode Test Code Base Station Simulator
4. Test Configuration With Belt Clip Without Belt Clip N/A
5. Tissue Depth is at least 15.0 cm



 Jay M. Moulton
 Vice President

SAR Data Summary – 1900 MHz Body – LTE Band 2

MEASUREMENT RESULTS

Gap	Plot	Position	Frequency		BW/ Modulation	RB Size	RB Offset	MPR Target	End Power (dBm)	Measured SAR (W/kg)	Reported SAR (W/kg)
			MHz	Ch.							
10 mm	----	Side A	1860.0	18700	20 MHz/QPSK	1	49	0	22.39	0.777	0.80
	----		1880.0	18900	20 MHz/QPSK	1	49	0	22.47	0.934	0.94
	7		1900.0	19100	20 MHz/QPSK	1	49	0	22.20	0.964	1.03
	----		1860.0	18700	20 MHz/QPSK	50	25	1	21.42	0.650	0.74
	----		1880.0	18900	20 MHz/QPSK	50	25	1	21.56	0.804	0.89
	----		1900.0	19100	20 MHz/QPSK	50	25	1	21.12	0.768	0.94
	----	1900.0	19100	20 MHz/QPSK	100	0	1	21.19	0.672	0.81	
	----	Side B	1880.0	18900	20 MHz/QPSK	1	49	0	22.47	0.454	0.46
	----		1880.0	18900	20 MHz/QPSK	50	25	1	21.56	0.365	0.40
	----	Side C	1880.0	18900	20 MHz/QPSK	1	49	0	22.47	0.654	0.66
	----		1880.0	18900	20 MHz/QPSK	50	25	1	21.56	0.509	0.56
	----	Side D	1880.0	18900	20 MHz/QPSK	1	49	0	22.47	0.0869	0.09
	----		1880.0	18900	20 MHz/QPSK	50	25	1	21.56	0.0761	0.08
	----	Side E	1860.0	18700	20 MHz/QPSK	1	49	0	22.39	0.674	0.69
	----		1880.0	18900	20 MHz/QPSK	1	49	0	22.47	0.804	0.81
	----		1900.0	19100	20 MHz/QPSK	1	49	0	22.20	0.630	0.68
	----		1880.0	18900	20 MHz/QPSK	50	25	1	21.56	0.585	0.65
	----	Repeat		1860.0	18700	20 MHz/QPSK	1	49	0	22.20	0.948

Body
1.6 W/kg (mW/g)
averaged over 1 gram

1. Battery is fully charged for all tests.
Power Measured Conducted ERP EIRP
2. SAR Measurement
Phantom Configuration Left Head Eli4 Right Head
SAR Configuration Head Body
3. Test Signal Call Mode Test Code Base Station Simulator
4. Test Configuration With Belt Clip Without Belt Clip N/A
5. Tissue Depth is at least 15.0 cm



Jay M. Moulton
Vice President

SAR Data Summary – 3600 MHz Body – LTE Band 48

MEASUREMENT RESULTS

Gap	Plot	Position	Frequency		BW/ Modulation	RB Size	RB Offset	MPR Target	End Power (dBm)	Measured SAR (W/kg)	Reported SAR (W/kg)
			MHz	Ch.							
10 mm	8	Side A	3625	55990	20 MHz/QPSK	1	49	0	23.38	0.577	0.67
	-----		3625	55990	20 MHz/QPSK	50	25	1	22.64	0.557	0.61
	-----	Side C	3625	55990	20 MHz/QPSK	1	49	0	23.38	0.385	0.44
	-----		3625	55990	20 MHz/QPSK	50	25	1	22.64	0.312	0.34
	-----	Side D	3625	55990	20 MHz/QPSK	1	49	0	23.38	0.376	0.43
	-----		3625	55990	20 MHz/QPSK	50	25	1	22.64	0.309	0.34
	-----	Side E	3625	55990	20 MHz/QPSK	1	49	0	23.38	0.437	0.50
	-----		3625	55990	20 MHz/QPSK	50	25	1	22.64	0.370	0.40

Body
1.6 W/kg (mW/g)
averaged over 1 gram

1. Battery is fully charged for all tests.
Power Measured Conducted ERP EIRP
2. SAR Measurement
Phantom Configuration Left Head Eli4 Right Head
SAR Configuration Head Body
3. Test Signal Call Mode Test Code Base Station Simulator
4. Test Configuration With Belt Clip Without Belt Clip N/A
5. Tissue Depth is at least 15.0 cm



Jay M. Moulton
Vice President

SAR Data Summary – 2450 MHz Body 802.11b

MEASUREMENT RESULTS

Gap	Plot	Position	Frequency		Modulation	Antenna	End Power	Measured SAR (W/kg)	Reported SAR (W/kg)
			MHz	Ch.			(dBm)		
10 mm	-----	Side A	2437	6	DSSS	Tx0	13.4	0.0527	0.06
	-----	Side B	2437	6	DSSS		13.4	0.0562	0.07
	-----	Side C	2437	6	DSSS		13.4	0.0643	0.07
	-----	Side F	2437	6	DSSS		13.4	0.0302	0.04
	-----	Side A	2437	6	DSSS	Tx1	13.3	0.0418	0.05
	9	Side C	2437	6	DSSS		13.3	0.0990	0.12
	-----	Side D	2437	6	DSSS		13.3	0.0172	0.02
	-----	Side F	2437	6	DSSS		13.3	0.0299	0.04

Body
1.6 W/kg (mW/g)
 averaged over 1 gram

1. Battery is fully charged for all tests.
 Power Measured Conducted ERP EIRP
2. SAR Measurement
 Phantom Configuration Left Head Eli4 Right Head
 SAR Configuration Head Body
3. Test Signal Call Mode Test Code Base Station Simulator
4. Test Configuration With Belt Clip Without Belt Clip N/A
5. Tissue Depth is at least 15.0 cm

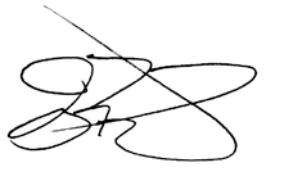

Jay M. Moulton
 Vice President

SAR Data Summary – 5200 MHz Body 802.11a

MEASUREMENT RESULTS

Gap	Plot	Position	Frequency		Modulation	Antenna	End Power	Measured SAR (W/kg)	Reported SAR (W/kg)
			MHz	Ch.			(dBm)		
10 mm	-----	Side A	5220	44	OFDM	Tx0	13.7	0.0548	0.06
	11	Side B	5220	44	OFDM		13.7	0.0851	0.09
	-----	Side C	5220	44	OFDM		13.7	0.125	0.13
	-----	Side F	5220	44	OFDM		13.7	0.0437	0.05
	-----	Side A	5220	44	OFDM	Tx1	13.6	0.0574	0.06
	-----	Side C	5220	44	OFDM		13.6	0.221	0.24
	-----	Side D	5220	44	OFDM		13.6	0.0149	0.02
	-----	Side F	5220	44	OFDM		13.6	0.0285	0.03

Body
1.6 W/kg (mW/g)
 averaged over 1 gram

1. Battery is fully charged for all tests.
 Power Measured Conducted ERP EIRP
2. SAR Measurement
 Phantom Configuration Left Head Eli4 Right Head
 SAR Configuration Head Body
3. Test Signal Call Mode Test Code Base Station Simulator
4. Test Configuration With Belt Clip Without Belt Clip N/A
5. Tissue Depth is at least 15.0 cm

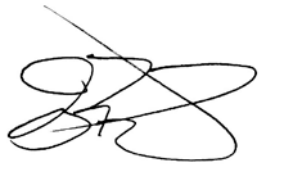

Jay M. Moulton
 Vice President

SAR Data Summary – 5800 MHz Body 802.11a

MEASUREMENT RESULTS

Gap	Plot	Position	Frequency		Modulation	Antenna	End Power	Measured SAR (W/kg)	Reported SAR (W/kg)
			MHz	Ch.			(dBm)		
10 mm	-----	Side A	5785	157	OFDM	Tx0	13.9	0.0936	0.10
	-----	Side B	5785	157	OFDM		13.9	0.0506	0.05
	-----	Side C	5785	157	OFDM		13.9	0.0805	0.08
	-----	Side F	5785	157	OFDM		13.9	0.0948	0.10
	-----	Side A	5785	157	OFDM	Tx1	13.7	0.0447	0.05
	11	Side C	5785	157	OFDM		13.7	0.160	0.17
	-----	Side D	5785	157	OFDM		13.7	0.0214	0.02
	-----	Side F	5785	157	OFDM		13.7	0.0283	0.03

Body
1.6 W/kg (mW/g)
 averaged over 1 gram

1. Battery is fully charged for all tests.
 Power Measured Conducted ERP EIRP
2. SAR Measurement
 Phantom Configuration Left Head Eli4 Right Head
 SAR Configuration Head Body
3. Test Signal Call Mode Test Code Base Station Simulator
4. Test Configuration With Belt Clip Without Belt Clip N/A
5. Tissue Depth is at least 15.0 cm

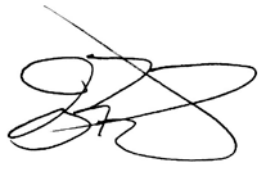

Jay M. Moulton
 Vice President

SAR Data Summary – Simultaneous Transmit (Worst Case) Ant 0 – WiFi

MEASUREMENT RESULTS								
Side	Frequency (WLAN)		Frequency (WWAN)		WWAN Technology	SAR (W/kg) WLAN	SAR (W/kg) WWAN	Total SAR (W/kg)
	MHz	Ch.	MHz	Ch.				
All	5520	44	1752.6	1512	WCDMA	0.24	1.18	1.42
Body 1.6 W/kg (mW/g) averaged over 1 gram								

The sum of the two transmitters is less than the limit; therefore, the simultaneous transmission meets the requirements of KDB447498 D01 v06 section 4.3.2 page 11.

SAR Data Summary – Simultaneous Transmit (Worst Case) Ant 4 – WiFi

MEASUREMENT RESULTS								
Side	Frequency (WLAN)		Frequency (WWAN)		WWAN Technology	SAR (W/kg) WLAN	SAR (W/kg) WWAN	Total SAR (W/kg)
	MHz	Ch.	MHz	Ch.				
All	5520	44	3625.0	55990	LTE Band 48	0.24	0.67	0.91
Body 1.6 W/kg (mW/g) averaged over 1 gram								

The sum of the two transmitters is less than the limit; therefore, the simultaneous transmission meets the requirements of KDB447498 D01 v06 section 4.3.2 page 11.

Carrier Aggregation Evaluation

Downlink Only Carrier Aggregation

This device supports LTE Carrier Aggregation (CA) in the downlink. All uplink communications are identical to Release 8 specifications. Per FCC KDB Publication 941225 D05A v01r02 and Fall 2017 TCB Workshop Notes, SAR for LTE CA operations was not needed since the maximum average output power in LTE CA mode was not >0.25 dB higher than the maximum output power when downlink carrier aggregation was inactive. DLCA power measurements can be found in Appendix H and table of CA DL combinations in Table 1.

Conducted power measurements with LTE Carrier Aggregation (CA) (downlink only) active are made in accordance to KDB Publication 941225 D05A v01r02. The RRC connection is only handled by one cell, the primary component carrier (PCC) for downlink and uplink communications. After making a data connection to the PCC, the UE device adds secondary component carrier(s) (SCC) on the downlink only. All uplink communications and acknowledgements remain identical to specifications when downlink carrier aggregation is inactive on the PCC. For every supported combination of downlink only carrier aggregation, additional conducted output power are measured with the downlink carrier aggregation active for the configuration with the highest measured maximum conducted power with downlink carrier aggregation inactive measured among the channel bandwidth, modulation and RB combinations in each frequency band. Per FCC KDB Publication 941225 D05A v01r02, no SAR measurements are required for carrier aggregation configurations when the average output power with downlink only carrier aggregation active is not more than 0.25 dB higher than the average output power with the downlink only carrier aggregation inactive.

Uplink Only Carrier Aggregation

This device supports LTE Carrier Aggregation (CA) in the uplink for LTE Band 2, Band 4, Band 5, Band 13, Band 48 and Band 66 with two component carriers in the uplink. SAR measurements and conducted powers were evaluated per 2017 Fall TCB Workshop Notes and 2018 Fall TCB Workshop Notes.

For LTE Band 2, Band 4, Band 5, Band 13, Band 48 and Band 66, per Fall 2018 Workshop Notes, SAR was first measured with only a single carrier active in the uplink (carrier aggregation not active). For each inter-band exposure condition, the single uplink SAR values are provided in table 2 below. If the single uplink 1 gram SAR values for each band are both less than 0.8 W/kg and the algebraic summation of the 1 gram SAR values are less than 1.45 W/kg no additional measurements are required. See table 3 below for results.

For LTE Band 5, Band 48 and Band 66, per Fall 2017 Workshop Notes, SAR was first measured with only a single carrier active in the uplink (carrier aggregation not active). For each intra-band exposure condition, the uplink CA scenario with two component carriers was additionally tested for the configuration with the highest SAR when carrier aggregation was not active. The SCC was configured with the closest available contiguous channel. The two component carriers were configured so the resource blocks are physically allocated side by side to achieve the maximum output power. When the reported 1 gram SAR was >1.2 W/kg or the reported 10 gram SAR was >3.0 W/kg, all required test channels were additionally evaluated. See table 4 below for the results.

MIMO

This device only supports LTE downlink 4x4 MIMO. Per Fall 2017 TCB Workshop Notes, SAR for LTE MIMO operations was not needed since the maximum average output power in LTE MIMO mode was not >0.25 dB higher than the maximum output power when MIMO is inactive. See Appendix H for conducted power data.

Table 1 – Carrier Aggregation Downlink Combinations

1 Band/2CC	2 Band/2CC	2 Band/3CC	3 Band/3CC	2 Band/4CC	3 Band/4CC	4 Band/4CC	2 Band/5CC	3 Band/5CC	4 Band/5CC	3 Band/6CC
2A-2A	2A-4A	2A-2A-4A	2A-4A-5A	2A-2A-4A-4A	2A-2A-4A-5A	XXXXX	XXXXX	XXXXX	XXXXX	XXXXX
XXXXX	2A-5A	2A-2A-5A	2A-5A-66A	XXXXX	2A-2A-5A-66A	2A-5A-48A-66A	XXXXX	XXXXX	2A-5A-48D	XXXXX
XXXXX	XXXXX	2A-5B	XXXXX	XXXXX	XXXXX	XXXXX	XXXXX	XXXXX	XXXXX	XXXXX
XXXXX	2A-13A	2A-2A-13A	2A-13A-66A	XXXXX	2A-2A-13A-66A	2A-13A-48A-66A	XXXXX	XXXXX	2A-13A-48D	XXXXX
XXXXX	2A-66A	2A-2A-66A	XXXXX	2A-2A-66A-66A	XXXXX	XXXXX	XXXXX	XXXXX	2A-48A-48C-66A	XXXXX
4A-4A	XXXXX	4A-4A-2A	XXXXX	XXXXX	4A-4A-2A-5A	XXXXX	XXXXX	XXXXX	XXXXX	2A-66A-48E
XXXXX	4A-5A	4A-4A-5A	XXXXX	XXXXX	4A-4A-5B	XXXXX	XXXXX	XXXXX	XXXXX	XXXXX
XXXXX	4A-13A	4A-4A-13A	4A-2A-13A	XXXXX	XXXXX	XXXXX	XXXXX	XXXXX	XXXXX	XXXXX
5A-5A	5A-66A	5A-5A-66A	XXXXX	5A-48D	XXXXX	XXXXX	XXXXX	5A-48A-48D	XXXXX	XXXXX
5B	XXXXX	5B-4A	XXXXX	XXXXX	5B-2A-4A	XXXXX	XXXXX	XXXXX	XXXXX	XXXXX
XXXXX	XXXXX	5B-66A	XXXXX	5B-66A-66A	5B-2A-66A	XXXXX	XXXXX	XXXXX	XXXXX	XXXXX
66A-66A	XXXXX	66A-66A-2A	XXXXX	XXXXX	66A-66A-2A-5A	XXXXX	XXXXX	66A-66A-2A-2A-5A	XXXXX	XXXXX
XXXXX	XXXXX	66A-66A-5A	XXXXX	66A-66A-5A-5A	XXXXX	XXXXX	XXXXX	XXXXX	XXXXX	XXXXX
XXXXX	66A-13A	66A-66A-13A	XXXXX	XXXXX	66A-66A-2A-13A	XXXXX	XXXXX	XXXXX	XXXXX	XXXXX
66B	XXXXX	66B-2A	XXXXX	66B-2A-5A	66B-2A-2A	XXXXX	XXXXX	66B-2A-2A-5A	XXXXX	XXXXX
XXXXX	XXXXX	66B-5A	XXXXX	66B-5A-5A	66B-13A-48A	XXXXX	XXXXX	XXXXX	XXXXX	XXXXX
XXXXX	XXXXX	XXXXX	XXXXX	66B-5B	XXXXX	XXXXX	XXXXX	66B-5B-2A	XXXXX	XXXXX
XXXXX	XXXXX	66B-13A	XXXXX	XXXXX	66B-2A-13A	XXXXX	XXXXX	XXXXX	XXXXX	XXXXX
66C	XXXXX	66C-2A	XXXXX	66C-2A-2A	XXXXX	XXXXX	XXXXX	XXXXX	XXXXX	XXXXX
XXXXX	XXXXX	XXXXX	XXXXX	XXXXX	66C-2A-5A	XXXXX	XXXXX	66C-2A-2A-5A	XXXXX	XXXXX
XXXXX	XXXXX	66C-5A	XXXXX	66C-5A-5A	XXXXX	XXXXX	XXXXX	XXXXX	XXXXX	XXXXX
XXXXX	XXXXX	XXXXX	XXXXX	66C-5B	XXXXX	XXXXX	XXXXX	66C-5B-2A	XXXXX	XXXXX
XXXXX	XXXXX	66C-13A	XXXXX	XXXXX	66C-2A-13A	XXXXX	XXXXX	XXXXX	XXXXX	XXXXX
XXXXX	XXXXX	XXXXX	XXXXX	XXXXX	66C-13A-48A	XXXXX	XXXXX	XXXXX	XXXXX	XXXXX
XXXXX	XXXXX	66C-66A	XXXXX	XXXXX	XXXXX	XXXXX	XXXXX	XXXXX	XXXXX	XXXXX
XXXXX	48A-2A	48A-48A-2A	48A-2A-66A	XXXXX	48A-48A-2A-13A	XXXXX	48E-2A	2A-5A-48A-48C	XXXXX	XXXXX
XXXXX	48A-4A	XXXXX	XXXXX	XXXXX	XXXXX	XXXXX	48E-4A	XXXXX	XXXXX	XXXXX
XXXXX	48A-5A	48A-48A-5A	48A-2A-13A	XXXXX	48A-48A-5A-2A	XXXXX	XXXXX	48A-5A-48C-66A	XXXXX	XXXXX
XXXXX	48A-13A	48A-48A-13A	48A-13A-66A	XXXXX	48A-48A-13A-66A	XXXXX	XXXXX	XXXXX	XXXXX	XXXXX
XXXXX	48A-66A	48A-48A-66A	XXXXX	48A-48A-66A-66A	XXXXX	XXXXX	XXXXX	XXXXX	48A-48A-66A-2A-13A	XXXXX
XXXXX	XXXXX	48A-66A-66A	XXXXX	48A-48C-5A	48A-48A-5A-66A	XXXXX	XXXXX	XXXXX	XXXXX	XXXXX
XXXXX	XXXXX	48A-66B	XXXXX	48A-48A-66B	XXXXX	XXXXX	XXXXX	XXXXX	XXXXX	XXXXX
XXXXX	XXXXX	48A-66C	XXXXX	48A-48A-66C	XXXXX	XXXXX	XXXXX	XXXXX	XXXXX	XXXXX
XXXXX	XXXXX	48C-2A	XXXXX	XXXXX	48C-2A-13A	XXXXX	XXXXX	48C-2A-13A-48A	48C-2A-13A-66A	XXXXX
XXXXX	XXXXX	48C-5A	XXXXX	XXXXX	48C-5A-2A	XXXXX	48C-48C-5A	XXXXX	48C-5A-2A-66A	XXXXX
XXXXX	XXXXX	48C-4A	XXXXX	XXXXX	XXXXX	XXXXX	XXXXX	XXXXX	XXXXX	XXXXX
XXXXX	XXXXX	48C-13A	XXXXX	XXXXX	48C-13A-66A	XXXXX	48C-48C-2A	48C-13A-66B	XXXXX	XXXXX
XXXXX	XXXXX	48C-66A	XXXXX	48C-48A-66A	48C-66A-5A	XXXXX	48C-48C-66A	XXXXX	XXXXX	XXXXX
XXXXX	XXXXX	XXXXX	XXXXX	48C-66B	XXXXX	XXXXX	XXXXX	XXXXX	XXXXX	XXXXX
XXXXX	XXXXX	XXXXX	XXXXX	48C-66C	XXXXX	XXXXX	XXXXX	48C-66C-13A	XXXXX	XXXXX
XXXXX	XXXXX	XXXXX	XXXXX	XXXXX	XXXXX	XXXXX	48D-48A-2A	XXXXX	XXXXX	XXXXX
XXXXX	XXXXX	XXXXX	XXXXX	XXXXX	XXXXX	XXXXX	48E-5A	XXXXX	XXXXX	XXXXX

Table 2 – SAR Data Summary – Body – LTE Bands 2, 4, 5, 13, 48, 66 Stand Alone SAR with Maximum TX Power Set to CA Power Level

MEASUREMENT RESULTS											
Gap	Plot	Position	Frequency		BW/ Modulation	RB Size	RB Offset	MPR Target	End Power (dBm)	Measured SAR (W/kg)	Reported SAR (W/kg)
			MHz	Ch.							
10 mm	-----	Side A	1900.0	19100	20 MHz/QPSK	1	49	0	20.61	0.658	0.72
	-----		1745.0	20300	20 MHz/QPSK	1	49	0	20.89	0.572	0.59
	-----		836.5	20525	10 MHz/QPSK	1	25	0	20.79	0.298	0.31
	-----		782.0	23230	10 MHz/QPSK	1	25	0	20.66	0.416	0.45
	-----		3625.0	55990	20 MHz/QPSK	1	49	0	20.31	0.318	0.37
	-----		1780.0	132572	20 MHz/QPSK	1	49	0	20.79	0.624	0.66
Body 1.6 W/kg (mW/g) averaged over 1 gram											

- Battery is fully charged for all tests.
Power Measured Conducted ERP EIRP
- SAR Measurement
Phantom Configuration Left Head Eli4 Right Head
SAR Configuration Head Body
- Test Signal Call Mode Test Code Base Station Simulator
- Test Configuration With Belt Clip Without Belt Clip N/A
- Tissue Depth is at least 15.0 cm



Jay M. Moulton
Vice President

Table 3 – SAR Data Summary –Uplink CA Inter-Band (Per Fall 2018 TCB Workshop Notes)

MEASUREMENT RESULTS								
Side	Frequency		Frequency		CA Combination	SAR ₁ (W/kg)	SAR ₂ (W/kg)	Total SAR (W/kg)
	MHz	Ch.	MHz	Ch.				
A	1900.0	19100	836.5	20525	2A-5A	0.72	0.31	1.03
	1900.0	19100	782.0	23230	2A-13A	0.72	0.45	1.17
	1745.0	20300	836.5	20525	4A-5A	0.59	0.31	0.90
	1745.0	20300	782.0	23230	4A-13A	0.59	0.45	1.04
	836.5	20525	1780.0	132572	5A-66A	0.31	0.66	0.97
	782.0	23230	1780.0	132572	13A-66A	0.45	0.66	1.11
	1900.0	19100	3625.0	55990	2A-48A	0.72	0.37	1.09
	3625.0	55990	1780.0	132572	48A-66A	0.37	0.66	1.03
	3625.0	55990	3605.0	55790	48C	0.37	0.34	0.71
Body 1.6 W/kg (mW/g) averaged over 1 gram								

Table 4 – SAR Data Summary –Uplink CA Intra-Band

MEASUREMENT RESULTS											
Side	Gap	Frequency		BW (MHz)	Mod.	RB Size	RB Offset	CC	Duty Cycle	SAR (W/kg)	Reported SAR (W/kg)
		MHz	Ch.								
A	10 mm	835.1	20511	10	QPSK	1	49	PCC	1:1	0.578	0.59
		844.0	20600	10		1	0	SCC	1:1		
		1775.0	132622	10	QPSK	1	0	PCC	1:1	0.842	0.93
		1765.2	132524	10		1	49	SCC	1:1		
		1770.0	132572	20	QPSK	1	0	PCC	1:1	0.822	0.91
		1750.2	132374	20		1	49	SCC	1:1		
		3625.0	55990	20	QPSK	1	49	PCC	1:1.58	0.513	0.59
		3644.8	56188	20		1	0	SCC	1:1.58		
Body 1.6 W/kg (mW/g) averaged over 1 gram											

MPR is 0 for measurements.

SAR Data Summary – Simultaneous Transmit 4G/WiFi/5G

MEASUREMENT RESULTS								
Side	Frequency (WLAN)		Frequency (WWAN)		WWAN Technology	SAR (W/kg) WLAN	SAR (W/kg) WWAN	Total SAR (W/kg)
	MHz	Ch.	MHz	Ch.				
All	5520	44	1900	19100	WCDMA	0.24	1.03	1.27
						Body 1.6 W/kg (mW/g) averaged over 1 gram		

The sum of the two transmitters is less than the limit; therefore, the simultaneous transmission meets the requirements of KDB447498 D01 v06 section 4.3.2 page 11.

In order to meet the simultaneous evaluation for all three transmitters, a volume scan was conducted on the highest SAR value for the WLAN and WWAN (anchor band). The final SAR value for simultaneous for 4G and WiFi is 1.05 W/kg. Please see plot 12 in appendix B for the simultaneous evaluation.

For the simultaneous evaluation for 4G/WiFi/5G, the ration of the SAR value for the 4G/WiFi to the limit and the ratio of the power density to the limit are added together. The sum must be less than 100%. Please see the calculations below for the evaluation.

$$\text{SAR} = 1.05 \text{ W/kg (Simultaneous Value)} / 1.6 \text{ W/kg (Limit)} = 65.6\%$$

$$\text{Power Density} = 2.55 \text{ W/m}^2 \text{ (Measured Value)} / 10 \text{ W/m}^2 \text{ (Limit)} = 25.5\%$$

The sum of the simultaneous ratio is 91.1%. Therefore, the simultaneous evaluation meets the requirements of KDB447498 v06.

11. Test Equipment List

Table 11.1 Equipment Specifications

Type	Calibration Due Date	Calibration Done Date	Serial Number
Staubli Robot TX60L	N/A	N/A	F07/55M6A1/A/01
Measurement Controller CS8c	N/A	N/A	1012
ELI5 Flat Phantom	N/A	N/A	2037
Device Holder	N/A	N/A	N/A
Data Acquisition Electronics 4	01/10/2020	01/10/2019	1321
SPEAG E-Field Probe EX3DV4	04/20/2019	04/20/2018	3662
SPEAG E-Field Probe EX3DV4	04/24/2020	04/24/2019	3662
Speag Validation Dipole D750V2	07/13/2019	07/13/2018	1016
Speag Validation Dipole D835V2	07/13/2019	07/13/2018	4d089
Speag Validation Dipole D1750V2	07/20/2019	07/20/2018	1018
Speag Validation Dipole D1900V2	07/13/2019	07/13/2018	5d116
Speag Validation Dipole D2450V2	07/12/2019	07/12/2018	829
Speag Validation Dipole D3500V2	04/13/2020	04/13/2018	1061
Speag Validation Dipole D3700V2	04/13/2020	04/13/2018	1024
Speag Validation Dipole D5GHzV2	07/19/2019	07/19/2018	1085
Agilent N1911A Power Meter	03/20/2020	03/20/2019	GB45100254
Agilent N1922A Power Sensor	06/21/2019	06/21/2017	MY45240464
Advantest R3261A Spectrum Analyzer	03/25/2020	03/25/2019	31720068
Agilent (HP) 8350B Signal Generator	03/20/2020	03/20/2019	2749A10226
Agilent (HP) 83525A RF Plug-In	03/20/2020	03/20/2019	2647A01172
Agilent (HP) 8753C Vector Network Analyzer	03/20/2020	03/20/2019	3135A01724
Agilent (HP) 85047A S-Parameter Test Set	03/20/2020	03/20/2019	2904A00595
Agilent (HP) 8960 Base Station Sim.	03/19/2020	03/19/2019	MY48360364
Anritsu MT8820C	01/26/2020	01/26/2019	6201176199
Agilent 778D Dual Directional Coupler	N/A	N/A	MY48220184
MiniCircuits BW-N20W5+ Fixed 20 dB Attenuator	N/A	N/A	N/A
MiniCircuits SPL-10.7+ Low Pass Filter	N/A	N/A	R8979513746
Apriel Dielectric Probe Assembly	N/A	N/A	0011
Body Equivalent Matter (750 MHz)	N/A	N/A	N/A
Body Equivalent Matter (835 MHz)	N/A	N/A	N/A
Body Equivalent Matter (1750 MHz)	N/A	N/A	N/A
Body Equivalent Matter (1900 MHz)	N/A	N/A	N/A
Body Equivalent Matter (2450 MHz)	N/A	N/A	N/A
Body Equivalent Matter (3-5 GHz)	N/A	N/A	N/A

12. Conclusion

The SAR measurement indicates that the EUT complies with the RF radiation exposure limits of the FCC/IC. These measurements are taken to simulate the RF effects exposure under worst-case conditions. Precise laboratory measures were taken to assure repeatability of the tests. The tested device complies with the requirements in respect to all parameters subject to the test. The test results and statements relate only to the item(s) tested.

Please note that the absorption and distribution of electromagnetic energy in the body is a very complex phenomena that depends on the mass, shape, and size of the body; the orientation of the body with respect to the field vectors; and, the electrical properties of both the body and the environment. Other variables that may play a substantial role in possible biological effects are those that characterize the environment (e.g. ambient temperature, air velocity, relative humidity, and body insulation) and those that characterize the individual (e.g. age, gender, activity level, debilitation, or disease). Because innumerable factors may interact to determine the specific biological outcome of an exposure to electromagnetic fields, any protection guide shall consider maximal amplification of biological effects as a result of field-body interactions, environmental conditions, and physiological variables.

13. References

- [1] Federal Communications Commission, ET Docket 93-62, Guidelines for Evaluating the Environmental Effects of Radio Frequency Radiation, August 1996

- [2] ANSI/IEEE C95.1 – 1992, American National Standard Safety Levels with respect to Human Exposure to Radio Frequency Electromagnetic Fields, 300kHz to 100GHz, New York: IEEE, 1992.

- [3] ANSI/IEEE C95.3 – 2002, IEEE Recommended Practice for the Measurement of Potentially Hazardous Electromagnetic Fields – RF and Microwave, New York: IEEE, 2002.

- [4] International Electrotechnical Commission, IEC 62209-2 (Edition 1.0), Human Exposure to radio frequency fields from hand-held and body mounted wireless communication devices – Human models, instrumentation, and procedures – Part 2: Procedure to determine the specific absorption rate (SAR) for wireless communication devices used in close proximity to the human body (frequency range of 30 MHz to 6 GHz), March 2010.

- [5] IEEE Standard 1528 – 2013, IEEE Recommended Practice for Determining the Peak-Spatial Average Specific Absorption Rate (SAR) in the Human Head from Wireless Communication Devices: Measurement Techniques, June 2013.

- [6] Industry Canada, RSS – 102 Issue 5, Radio Frequency Exposure Compliance of Radiocommunication Apparatus (All Frequency Bands), March 2015.

- [7] Health Canada, Safety Code 6, Limits of Human Exposure to Radiofrequency Electromagnetic Fields in the Frequency Range from 3kHz to 300 GHz, 2009.

Appendix A – System Validation Plots and Data

Test Result for UIM Dielectric Parameter

Tue 19/Feb/2019

Freq Frequency(GHz)

FCC_eB Limits for Body Epsilon

FCC_sB Limits for Body Sigma

Test_e Epsilon of UIM

Test_s Sigma of UIM

Freq	FCC_eB	FCC_sB	Test_e	Test_s
0.7000	55.73	0.96	54.68	0.97
0.7100	55.69	0.96	54.62	0.98
0.7200	55.65	0.96	54.57	0.99
0.7300	55.61	0.96	54.51	1.00
0.7400	55.57	0.96	54.47	1.01
0.7500	55.53	0.96	54.43	1.02
0.7600	55.49	0.96	54.39	1.03
0.7700	55.45	0.96	54.35	1.04
0.7800	55.41	0.97	54.31	1.05
0.7820	55.404	0.97	54.30	1.052*
0.7900	55.38	0.97	54.26	1.06
0.8000	55.34	0.97	54.21	1.06

* value interpolated

Test Result for UIM Dielectric Parameter

Tue 07/May/2019

Freq Frequency(GHz)

FCC_eB Limits for Body Epsilon

FCC_sB Limits for Body Sigma

Test_e Epsilon of UIM

Test_s Sigma of UIM

Freq	FCC_eB	FCC_sB	Test_e	Test_s
0.7000	55.73	0.96	55.72	0.97
0.7100	55.69	0.96	55.69	0.98
0.7200	55.65	0.96	55.66	0.98
0.7300	55.61	0.96	55.63	0.98
0.7400	55.57	0.96	55.60	0.99
0.7500	55.53	0.96	55.57	0.99
0.7600	55.49	0.96	55.54	0.99
0.7700	55.45	0.96	55.50	1.00
0.7800	55.41	0.97	55.46	1.00
0.7820	55.404	0.97	55.452	1.00*
0.7900	55.38	0.97	55.42	1.00
0.8000	55.34	0.97	55.38	1.01

* value interpolated

Test Result for UIM Dielectric Parameter

Fri 29/Mar/2019

Freq Frequency(GHz)

FCC_eB Limits for Body Epsilon

FCC_sB Limits for Body Sigma

Test_e Epsilon of UIM

Test_s Sigma of UIM

Freq	FCC_eB	FCC_sB	Test_e	Test_s
0.8050	55.32	0.97	54.72	0.96
0.8150	55.28	0.97	54.68	0.97
0.8250	55.24	0.97	54.63	0.98
0.8290	55.224	0.97	54.606	0.984*
0.8350	55.20	0.97	54.57	0.99
0.8365	55.195	0.972	54.564	0.992*
0.8450	55.17	0.98	54.53	1.00
0.8490	55.158	0.984	54.518	1.004*
0.8550	55.14	0.99	54.50	1.01
0.8650	55.11	1.01	54.47	1.02

* value interpolated

Test Result for UIM Dielectric Parameter

Tue 05/Mar/2019

Freq Frequency(GHz)

FCC_eB Limits for Body Epsilon

FCC_sB Limits for Body Sigma

Test_e Epsilon of UIM

Test_s Sigma of UIM

Freq	FCC_eB	FCC_sB	Test_e	Test_s
0.8050	55.32	0.97	54.24	0.94
0.8150	55.28	0.97	54.28	0.95
0.8250	55.24	0.97	54.33	0.96
0.8264	55.234	0.97	54.336	0.963*
0.8350	55.20	0.97	54.37	0.98
0.8366	55.195	0.972	54.375	0.982*
0.8450	55.17	0.98	54.40	0.99
0.8466	55.165	0.982	54.406	0.995*
0.8550	55.14	0.99	54.44	1.02
0.8650	55.11	1.01	54.48	1.04

* value interpolated

Test Result for UIM Dielectric Parameter

Tue 07/May/2019

Freq Frequency(GHz)

FCC_eB Limits for Body Epsilon

FCC_sB Limits for Body Sigma

Test_e Epsilon of UIM

Test_s Sigma of UIM

Freq	FCC_eB	FCC_sB	Test_e	Test_s
0.8050	55.32	0.97	56.05	0.96
0.8150	55.28	0.97	56.00	0.98
0.8250	55.24	0.97	55.95	0.98
0.8350	55.20	0.97	55.91	0.99
0.8365	55.196	0.972	55.905	0.991*
0.8550	55.14	0.99	55.84	1.00
0.8650	55.11	1.01	55.80	1.01
0.8750	55.08	1.02	55.78	1.03
0.8850	55.05	1.03	55.73	1.03
0.8950	55.02	1.04	55.70	1.04

* value interpolated

Test Result for UIM Dielectric Parameter

Thu 21/Feb/2019

Freq Frequency(GHz)

FCC_eB Limits for Body Epsilon

FCC_sB Limits for Body Sigma

Test_e Epsilon of UIM

Test_s Sigma of UIM

Freq	FCC_eB	FCC_sB	Test_e	Test_s
1.6900	53.59	1.45	52.87	1.49
1.7000	53.56	1.46	52.83	1.50
1.7100	53.54	1.46	52.79	1.51
1.7200	53.51	1.47	52.76	1.52
1.7300	53.48	1.48	52.72	1.53
1.7400	53.46	1.48	52.68	1.53
1.7450	53.445	1.485	52.67	1.535*
1.7500	53.43	1.49	52.66	1.54
1.7600	53.41	1.49	52.64	1.54
1.7700	53.38	1.50	52.63	1.55
1.7800	53.35	1.51	52.59	1.56
1.7900	53.33	1.51	52.56	1.57

* value interpolated

Test Result for UIM Dielectric Parameter

Wed 06/Mar/2019

Freq Frequency(GHz)

FCC_eB Limits for Body Epsilon

FCC_sB Limits for Body Sigma

Test_e Epsilon of UIM

Test_s Sigma of UIM

Freq	FCC_eB	FCC_sB	Test_e	Test_s
1.6900	53.59	1.45	52.89	1.51
1.7000	53.56	1.46	52.85	1.52
1.7100	53.54	1.46	52.81	1.53
1.7124	53.533	1.462	52.803	1.532*
1.7200	53.51	1.47	52.78	1.54
1.7300	53.48	1.48	52.74	1.55
1.7326	53.475	1.48	52.73	1.55*
1.7400	53.46	1.48	52.70	1.55
1.7500	53.43	1.49	52.68	1.56
1.7526	53.425	1.49	52.675	1.56*
1.7600	53.41	1.49	52.66	1.56
1.7700	53.38	1.50	52.65	1.57
1.7800	53.35	1.51	52.61	1.58
1.7900	53.33	1.51	52.58	1.59

* value interpolated

Test Result for UIM Dielectric Parameter

Tue 07/May/2019

Freq Frequency(GHz)

FCC_eB Limits for Body Epsilon

FCC_sB Limits for Body Sigma

Test_e Epsilon of UIM

Test_s Sigma of UIM

Freq	FCC_eB	FCC_sB	Test_e	Test_s
1.7100	53.53	1.47	53.55	1.48
1.7200	53.51	1.47	53.52	1.49
1.7300	53.48	1.48	53.38	1.50
1.7400	53.46	1.48	53.36	1.51
1.7450	53.445	1.485	53.34	1.515*
1.7500	53.43	1.49	53.32	1.52
1.7600	53.41	1.49	53.30	1.53
1.7700	53.38	1.50	53.27	1.55
1.7800	53.35	1.51	53.23	1.55

* value interpolated

Test Result for UIM Dielectric Parameter

Mon 11/Feb/2019

Freq Frequency(GHz)

FCC_eB Limits for Body Epsilon

FCC_sB Limits for Body Sigma

Test_e Epsilon of UIM

Test_s Sigma of UIM

Freq	FCC_eB	FCC_sB	Test_e	Test_s
1.8500	53.30	1.52	53.07	1.53
1.8600	53.30	1.52	53.05	1.54
1.8700	53.30	1.52	53.03	1.55
1.8800	53.30	1.52	53.01	1.56
1.8900	53.30	1.52	52.99	1.57
1.9000	53.30	1.52	52.97	1.58
1.9100	53.30	1.52	52.95	1.60
1.9200	53.30	1.52	52.94	1.61
1.9300	53.30	1.52	52.92	1.62

* value interpolated

Test Result for UIM Dielectric Parameter

Mon 04/Mar/2019

Freq Frequency(GHz)

FCC_eB Limits for Body Epsilon

FCC_sB Limits for Body Sigma

Test_e Epsilon of UIM

Test_s Sigma of UIM

Freq	FCC_eB	FCC_sB	Test_e	Test_s
1.8500	53.30	1.52	53.27	1.49
1.8524	53.30	1.52	53.265	1.492*
1.8600	53.30	1.52	53.25	1.50
1.8700	53.30	1.52	53.23	1.51
1.8800	53.30	1.52	53.21	1.52
1.8900	53.30	1.52	53.19	1.53
1.9000	53.30	1.52	53.17	1.54
1.9076	53.30	1.52	53.155	1.548*
1.9100	53.30	1.52	53.15	1.55
1.9200	53.30	1.52	53.14	1.57
1.9300	53.30	1.52	53.12	1.58

* value interpolated

Test Result for UIM Dielectric Parameter

Tue 07/May/2019

Freq Frequency(GHz)

FCC_eB Limits for Body Epsilon

FCC_sB Limits for Body Sigma

Test_e Epsilon of UIM

Test_s Sigma of UIM

Freq	FCC_eB	FCC_sB	Test_e	Test_s
1.8400	53.30	1.52	52.04	1.43
1.8500	53.30	1.52	52.03	1.44
1.8600	53.30	1.52	52.03	1.44
1.8700	53.30	1.52	52.14	1.45
1.8800	53.30	1.52	52.10	1.45
1.8900	53.30	1.52	52.17	1.46
1.9000	53.30	1.52	52.07	1.47
1.9100	53.30	1.52	52.12	1.50
1.9200	53.30	1.52	52.00	1.50

* value interpolated

Test Result for UIM Dielectric Parameter

Wed 13/Mar/2019

Freq Frequency(GHz)

FCC_eB Limits for Body Epsilon

FCC_sB Limits for Body Sigma

Test_e Epsilon of UIM

Test_s Sigma of UIM

Freq	FCC_eB	FCC_sB	Test_e	Test_s
2.4100	52.75	1.91	52.66	1.95
2.4120	52.748	1.912	52.656	1.952*
2.4200	52.74	1.92	52.64	1.96
2.4300	52.73	1.93	52.62	1.97
2.4370	52.716	1.937	52.606	1.984*
2.4400	52.71	1.94	52.60	1.99
2.4500	52.70	1.95	52.58	2.00
2.4600	52.69	1.96	52.57	2.01
2.4620	52.686	1.964	52.566	2.012*
2.4700	52.67	1.98	52.55	2.02
2.4800	52.66	1.99	52.53	2.03

* value interpolated

Test Result for UIM Dielectric Parameter

Sat 09/Mar/2019

Freq Frequency(GHz)

FCC_eB Limits for Body Epsilon

FCC_sB Limits for Body Sigma

Test_e Epsilon of UIM

Test_s Sigma of UIM

Freq	FCC_eB	FCC_sB	Test_e	Test_s
3.4800	51.35	3.30	51.13	3.32
3.4900	51.33	3.31	51.12	3.33
3.5000	51.32	3.32	51.11	3.34
3.5100	51.31	3.33	51.11	3.35
3.5200	51.29	3.34	51.10	3.36
3.5300	51.28	3.35	51.08	3.37
3.5400	51.27	3.36	51.07	3.38
3.5500	51.25	3.37	51.05	3.39
3.5600	51.24	3.38	51.03	3.40
3.5700	51.23	3.40	51.02	3.41
3.5800	51.21	3.41	51.00	3.42
3.5900	51.20	3.42	50.98	3.43
3.5925	51.198	3.423	50.978	3.433*
3.6000	51.19	3.43	50.97	3.44
3.6100	51.17	3.44	50.95	3.45
3.6200	51.16	3.45	50.94	3.46
3.6250	51.155	3.455	50.935	3.465*
3.6300	51.15	3.46	50.93	3.47
3.6400	51.13	3.47	50.92	3.48
3.6500	51.12	3.48	50.91	3.49
3.6575	51.113	3.488	50.903	3.498*
3.6600	51.11	3.49	50.90	3.50
3.6700	51.09	3.50	50.89	3.51
3.6800	51.08	3.51	50.88	3.52
3.6900	51.07	3.52	50.87	3.53
3.7000	51.05	3.53	50.86	3.54
3.7100	51.04	3.54	50.85	3.55
3.7200	51.03	3.55	50.84	3.56

* value interpolated

Test Result for UIM Dielectric Parameter

Tue 07/May/2019

Freq Frequency(GHz)

FCC_eB Limits for Body Epsilon

FCC_sB Limits for Body Sigma

Test_e Epsilon of UIM

Test_s Sigma of UIM

Freq	FCC_eB	FCC_sB	Test_e	Test_s
3.4800	51.35	3.30	50.95	3.31
3.4900	51.33	3.31	50.94	3.32
3.5000	51.32	3.32	50.93	3.33
3.5100	51.31	3.33	50.93	3.34
3.5200	51.29	3.34	50.92	3.35
3.5300	51.28	3.35	50.90	3.36
3.5400	51.27	3.36	50.89	3.37
3.5500	51.25	3.37	50.87	3.38
3.5600	51.24	3.38	50.85	3.39
3.5700	51.23	3.40	50.84	3.40
3.5800	51.21	3.41	50.82	3.41
3.5900	51.20	3.42	50.80	3.42
3.5925	51.198	3.423	50.798	3.423*
3.6000	51.19	3.43	50.79	3.43
3.6100	51.17	3.44	50.77	3.44
3.6200	51.16	3.45	50.76	3.45
3.6250	51.155	3.455	50.755	3.455*
3.6300	51.15	3.46	50.75	3.46
3.6400	51.13	3.47	50.74	3.47
3.6500	51.12	3.48	50.73	3.48
3.6575	51.113	3.488	50.723	3.488*
3.6600	51.11	3.49	50.72	3.49
3.6700	51.09	3.50	50.71	3.50
3.6800	51.08	3.51	50.70	3.51
3.6900	51.07	3.52	50.69	3.52
3.7000	51.05	3.53	50.68	3.53
3.7100	51.04	3.54	50.67	3.54
3.7200	51.03	3.55	50.66	3.55

* value interpolated

Test Result for UIM Dielectric Parameter

Mon 11/Mar/2019

Freq Frequency(GHz)

FCC_eB Limits for Body Epsilon

FCC_sB Limits for Body Sigma

Test_e Epsilon of UIM

Test_s Sigma of UIM

Freq	FCC_eB	FCC_sB	Test_e	Test_s
5.1000	49.15	5.18	49.09	5.22
5.1200	49.12	5.21	49.06	5.25
5.1400	49.10	5.23	49.03	5.27
5.1600	49.07	5.25	49.00	5.29
5.1800	49.04	5.28	48.97	5.31
5.2000	49.01	5.30	48.94	5.34
5.2200	48.99	5.32	48.92	5.36
5.2400	48.96	5.35	48.89	5.38
5.2500	48.945	5.36	48.875	5.395*
5.2600	48.93	5.37	48.86	5.41
5.2800	48.91	5.39	48.84	5.43
5.3000	48.88	5.42	48.81	5.45
5.3200	48.85	5.44	48.78	5.48
5.3400	48.82	5.46	48.75	5.50
5.3600	48.80	5.49	48.72	5.52
5.3800	48.77	5.51	48.69	5.54
5.4000	48.74	5.53	48.66	5.57
5.4200	48.72	5.56	48.63	5.59
5.4400	48.69	5.58	48.60	5.61
5.4600	48.66	5.60	48.57	5.63
5.4800	48.63	5.63	48.54	5.66
5.5000	48.61	5.65	48.51	5.68
5.5200	48.58	5.67	48.48	5.70
5.5400	48.55	5.70	48.45	5.73
5.5600	48.53	5.72	48.42	5.75
5.5800	48.50	5.74	48.39	5.77
5.6000	48.47	5.77	48.36	5.80
5.6200	48.44	5.79	48.33	5.83
5.6400	48.42	5.81	48.30	5.85
5.6600	48.39	5.84	48.27	5.87
5.6800	48.36	5.86	48.24	5.90
5.7000	48.34	5.88	48.21	5.93
5.7200	48.31	5.91	48.18	5.95
5.7400	48.28	5.93	48.15	5.97
5.7450	48.273	5.935	48.143	5.978*
5.7500	48.265	5.94	48.135	5.985*
5.7600	48.25	5.95	48.12	6.00
5.7800	48.23	5.98	48.09	6.03
5.7850	48.223	5.985	48.08	6.033*
5.8000	48.20	6.00	48.05	6.04
5.8200	48.17	6.02	48.02	6.06
5.8250	48.165	6.028	48.013	6.068*
5.8400	48.15	6.05	47.99	6.09

* value interpolated

RF Exposure Lab

Plot 1

DUT: Dipole 750 MHz D750V3; Type: D750V3; Serial: D750V3 - SN:1085

Communication System: CW; Frequency: 750 MHz; Duty Cycle: 1:1
Medium: MSL750; Medium parameters used: $f = 750$ MHz; $\sigma = 1.02$ S/m; $\epsilon_r = 54.43$; $\rho = 1000$ kg/m³
Phantom section: Flat Section

Test Date: Date: 2/19/2019; Ambient Temp: 23 °C; Tissue Temp: 21 °C

Probe: EX3DV4 - SN3662; ConvF(9.62, 9.62, 9.62); Calibrated: 4/20/2018;
Sensor-Surface: 2mm (Mechanical Surface Detection)
Electronics: DAE4 Sn1321; Calibrated: 1/10/2019
Phantom: ELI v5.0; Type: QDOVA002AA; Serial: 2037
Measurement SW: DASY52, Version 52.10 (0); SEMCAD X Version 14.6.10 (7417)

Procedure Notes:

750 MHz/Verification/Area Scan (5x11x1): Measurement grid: dx=15mm, dy=15mm
Maximum value of SAR (measured) = 1.07 W/kg

750 MHz/Verification/Zoom Scan (5x5x7)/Cube 0: Measurement grid: dx=8mm, dy=8mm, dz=5mm
Reference Value = 30.367 V/m; Power Drift = 0.03 dB
Peak SAR (extrapolated) = 1.29 W/kg
SAR(1 g) = 0.861 W/kg; SAR(10 g) = 0.564 W/kg
Maximum value of SAR (measured) = 1.09 W/kg

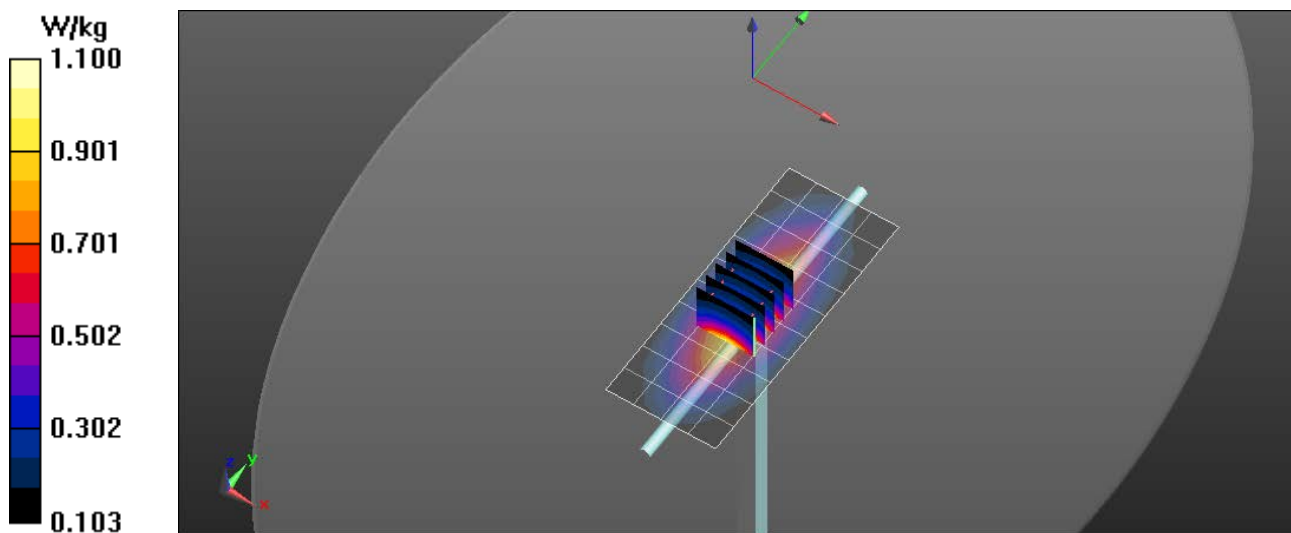

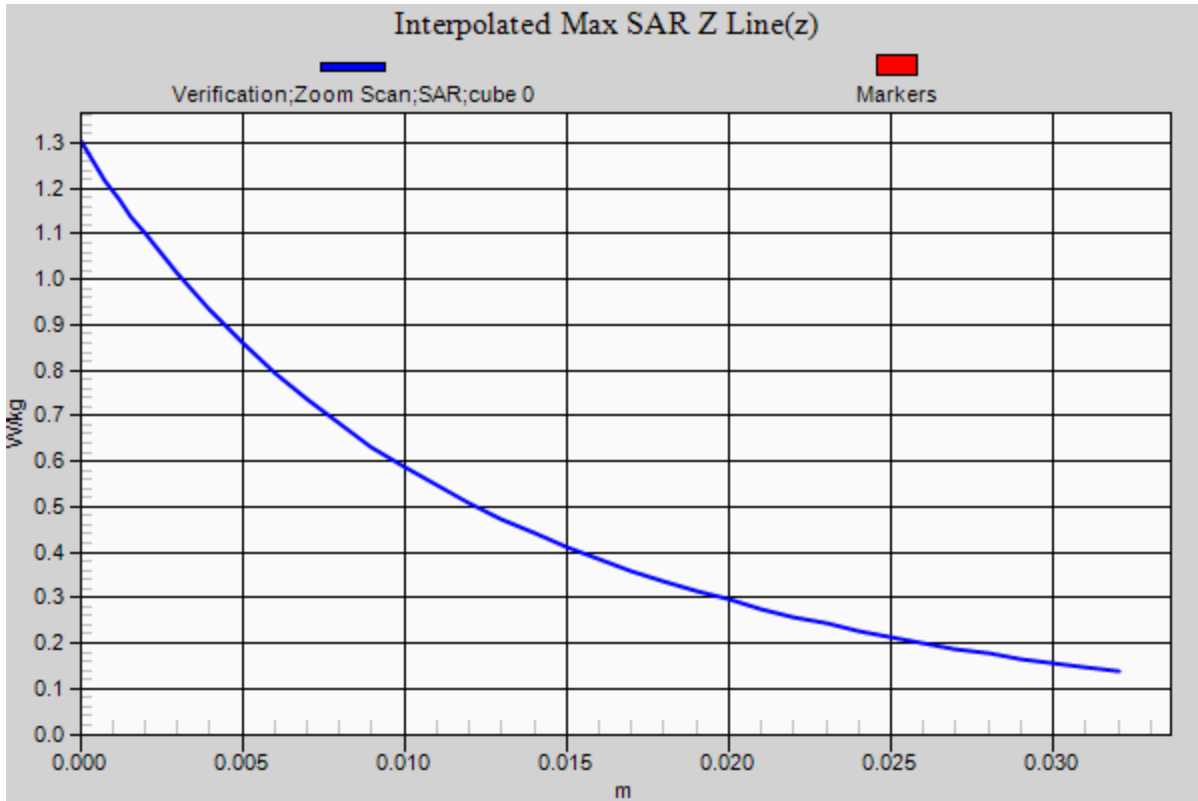

RF Exposure Lab

Plot 2

DUT: Dipole 835 MHz D835V2; Type: D835V2; Serial: D835V2 - SN:4d089

Communication System: CW; Frequency: 835 MHz; Duty Cycle: 1:1
 Medium: MSL835; Medium parameters used: $f = 835 \text{ MHz}$; $\sigma = 0.99 \text{ S/m}$; $\epsilon_r = 54.57$; $\rho = 1000 \text{ kg/m}^3$
 Phantom section: Flat Section

Test Date: Date: 2/18/2019; Ambient Temp: 23 °C; Tissue Temp: 21 °C

Probe: EX3DV4 - SN3662; ConvF(9.21, 9.21, 9.21); Calibrated: 4/20/2018;
 Sensor-Surface: 2mm (Mechanical Surface Detection)
 Electronics: DAE4 Sn1321; Calibrated: 1/10/2019
 Phantom: ELI v5.0; Type: QDOVA002AA; Serial: 2037
 Measurement SW: DASY52, Version 52.10 (0); SEMCAD X Version 14.6.10 (7417)

Procedure Notes:

835 MHz/Verification/Area Scan (5x11x1): Measurement grid: $dx=15\text{mm}$, $dy=15\text{mm}$
 Maximum value of SAR (measured) = 1.17 W/kg

835 MHz/Verification/Zoom Scan (5x5x7)/Cube 0: Measurement grid: $dx=8\text{mm}$, $dy=8\text{mm}$, $dz=5\text{mm}$
 Reference Value = 30.589 V/m; Power Drift = -0.02 dB
 Peak SAR (extrapolated) = 1.42 W/kg
SAR(1 g) = 0.961 W/kg; SAR(10 g) = 0.618 W/kg
 Maximum value of SAR (measured) = 1.17 W/kg

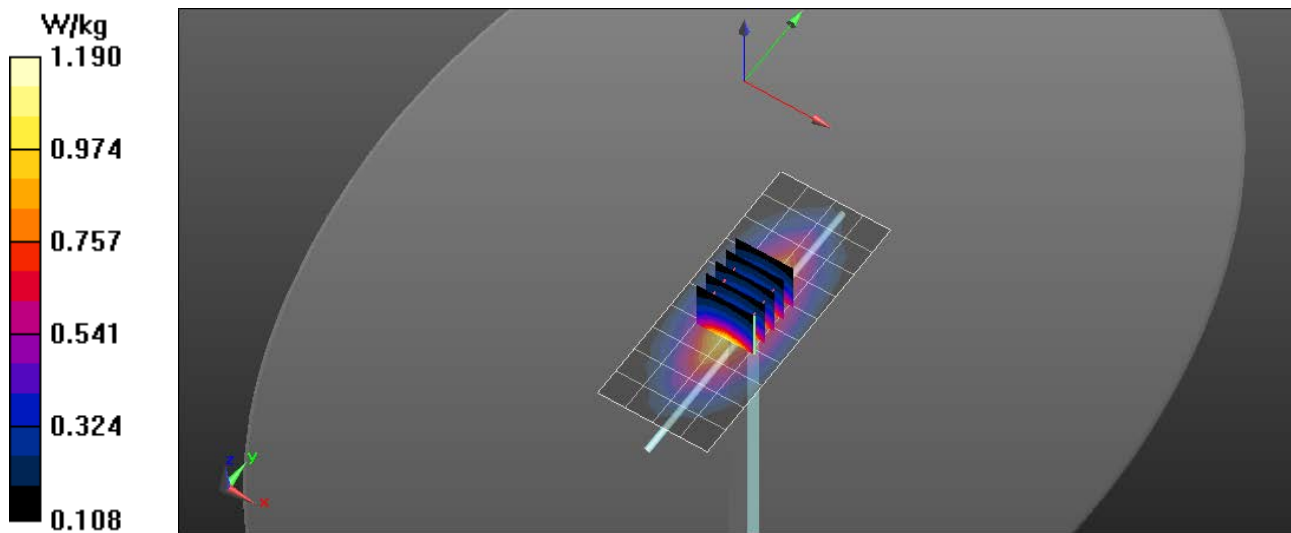

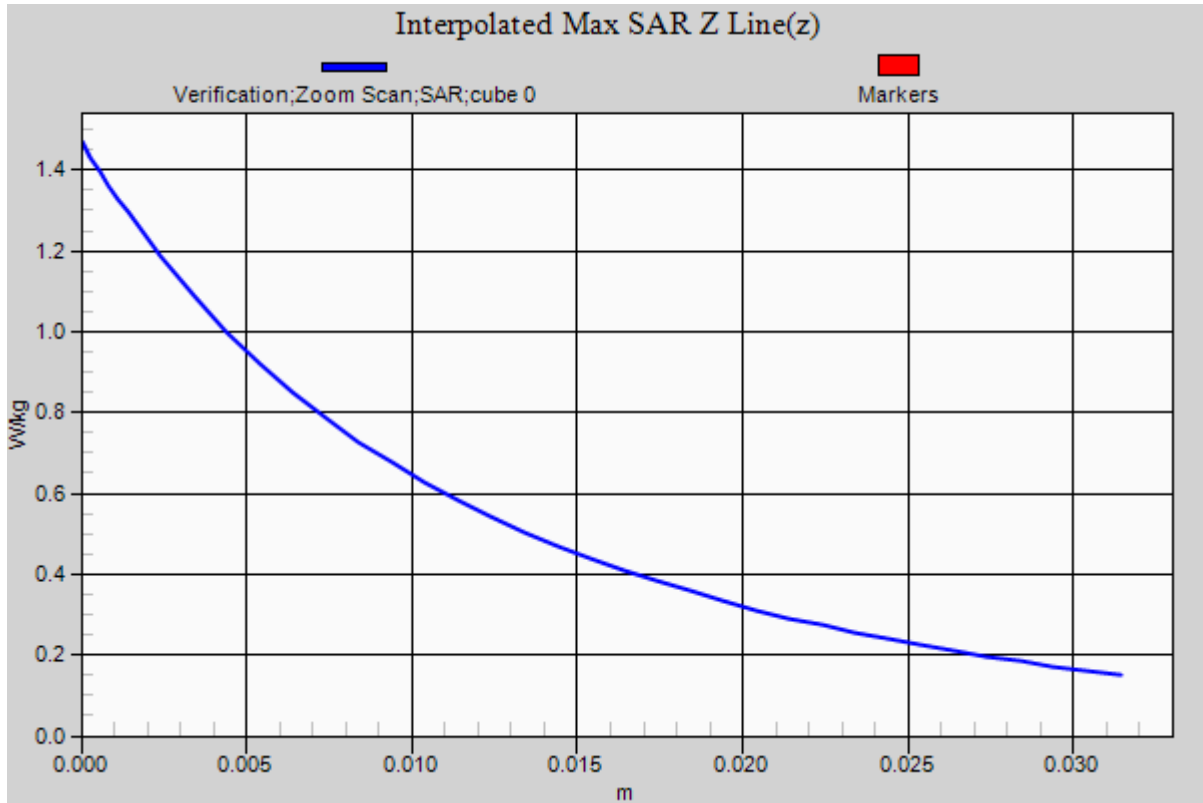

RF Exposure Lab

Plot 3

DUT: Dipole 835 MHz D835V2; Type: D835V2; Serial: D835V2 - SN:4d089

Communication System: CW; Frequency: 835 MHz; Duty Cycle: 1:1
Medium: MSL835; Medium parameters used: $f = 835$ MHz; $\sigma = 0.98$ S/m; $\epsilon_r = 54.37$; $\rho = 1000$ kg/m³
Phantom section: Flat Section

Test Date: Date: 3/5/2019; Ambient Temp: 23 °C; Tissue Temp: 21 °C

Probe: EX3DV4 - SN3662; ConvF(9.21, 9.21, 9.21); Calibrated: 4/20/2018;
Sensor-Surface: 2mm (Mechanical Surface Detection)
Electronics: DAE4 Sn1321; Calibrated: 1/10/2019
Phantom: ELI v5.0; Type: QDOVA002AA; Serial: 2037
Measurement SW: DASY52, Version 52.10 (0); SEMCAD X Version 14.6.10 (7417)

Procedure Notes:

835 MHz/Verification/Area Scan (5x11x1): Measurement grid: dx=15mm, dy=15mm
Maximum value of SAR (measured) = 1.18 W/kg

835 MHz/Verification/Zoom Scan (5x5x7)/Cube 0: Measurement grid: dx=8mm, dy=8mm, dz=5mm
Reference Value = 31.227 V/m; Power Drift = -0.01 dB
Peak SAR (extrapolated) = 1.47 W/kg
SAR(1 g) = 0.963 W/kg; SAR(10 g) = 0.629 W/kg

[Info: Interpolated medium parameters used for SAR evaluation.](#)
Maximum value of SAR (measured) = 1.19 W/kg

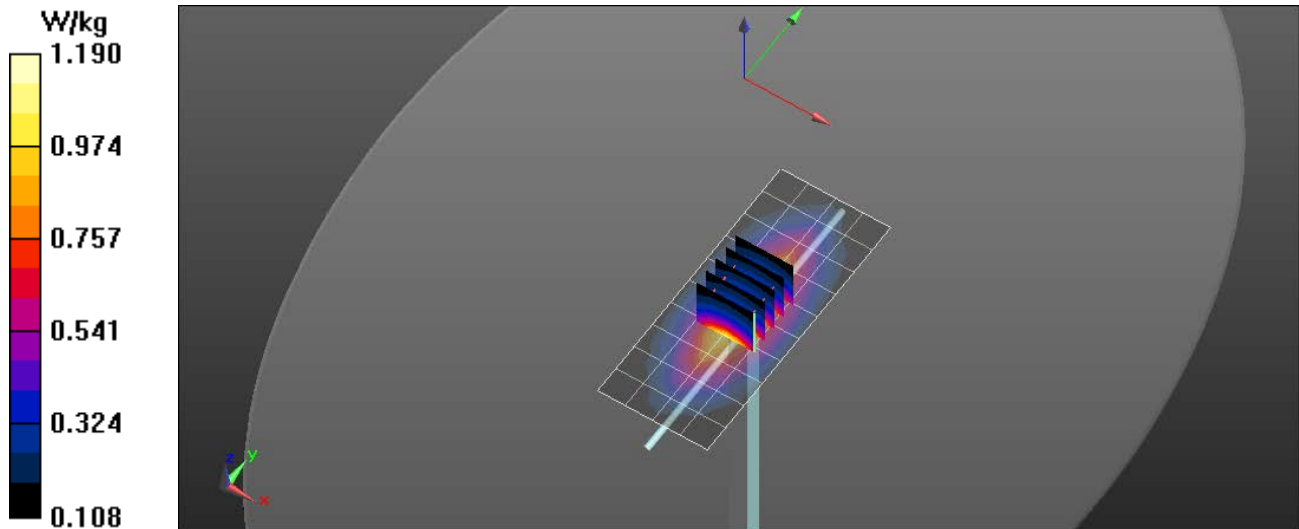

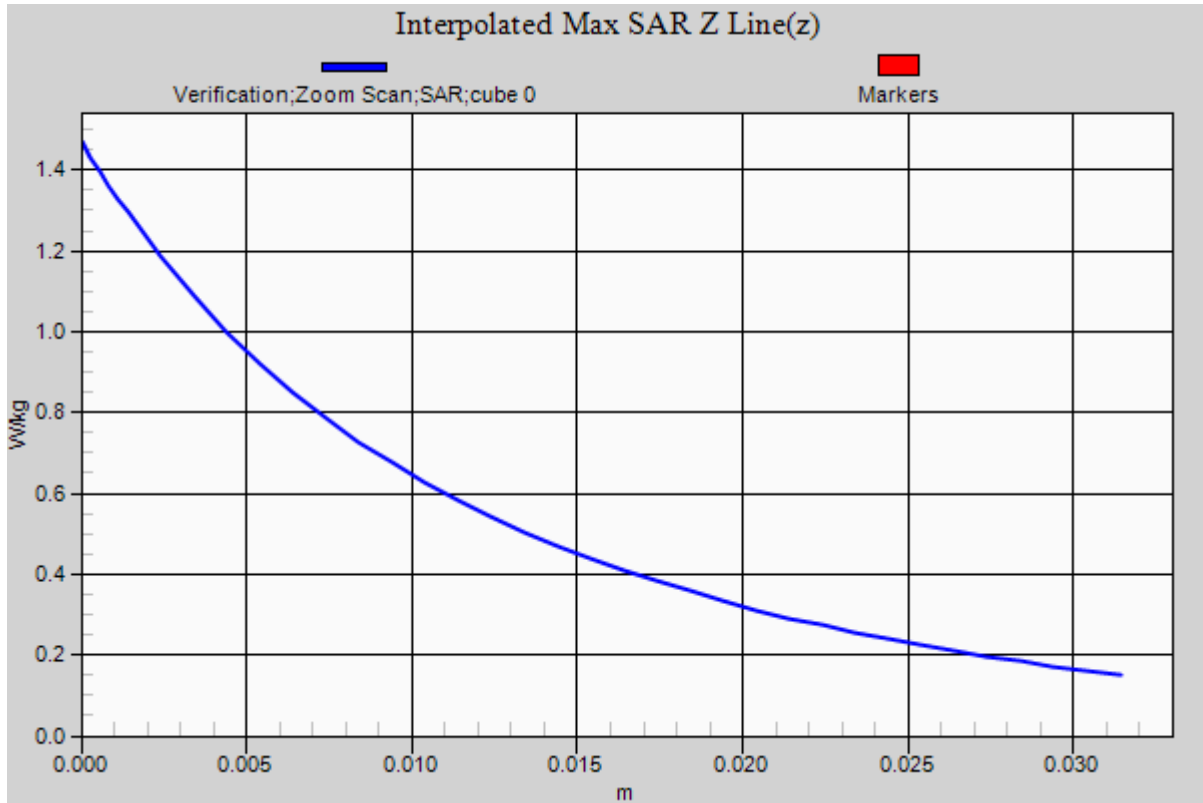

RF Exposure Lab

Plot 4

DUT: Dipole 1750 MHz D1750V2; Type: D1750V2; Serial: D1750V2 - SN:1018

Communication System: CW; Frequency: 1750 MHz; Duty Cycle: 1:1
Medium: MSL1750; Medium parameters used: $f = 1750$ MHz; $\sigma = 1.54$ S/m; $\epsilon_r = 52.66$; $\rho = 1000$ kg/m³
Phantom section: Flat Section

Test Date: Date: 2/21/2019; Ambient Temp: 23 °C; Tissue Temp: 21 °C

Probe: EX3DV4 - SN3662; ConvF(7.96, 7.96, 7.96); Calibrated: 4/20/2018;
Sensor-Surface: 2mm (Mechanical Surface Detection)
Electronics: DAE4 Sn1321; Calibrated: 1/10/2019
Phantom: ELI v5.0; Type: QDOVA002AA; Serial: 2037
Measurement SW: DASY52, Version 52.10 (0); SEMCAD X Version 14.6.10 (7417)

Procedure Notes:

1750 MHz/Verification/Area Scan (5x7x1): Measurement grid: dx=15mm, dy=15mm
Maximum value of SAR (measured) = 5.38 W/kg

1750 MHz/Verification/Zoom Scan (5x5x7)/Cube 0: Measurement grid: dx=8mm, dy=8mm, dz=5mm
Reference Value = 32.667 V/m; Power Drift = -0.03 dB
Peak SAR (extrapolated) = 6.92 W/kg
SAR(1 g) = 3.69 W/kg; SAR(10 g) = 2.04 W/kg
Maximum value of SAR (measured) = 5.48 W/kg

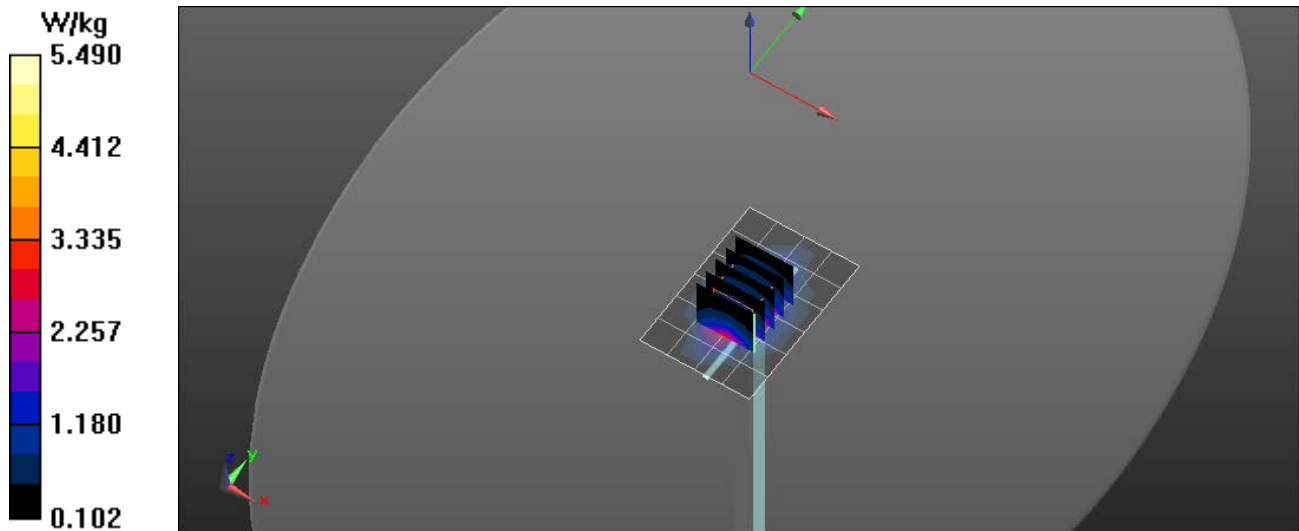

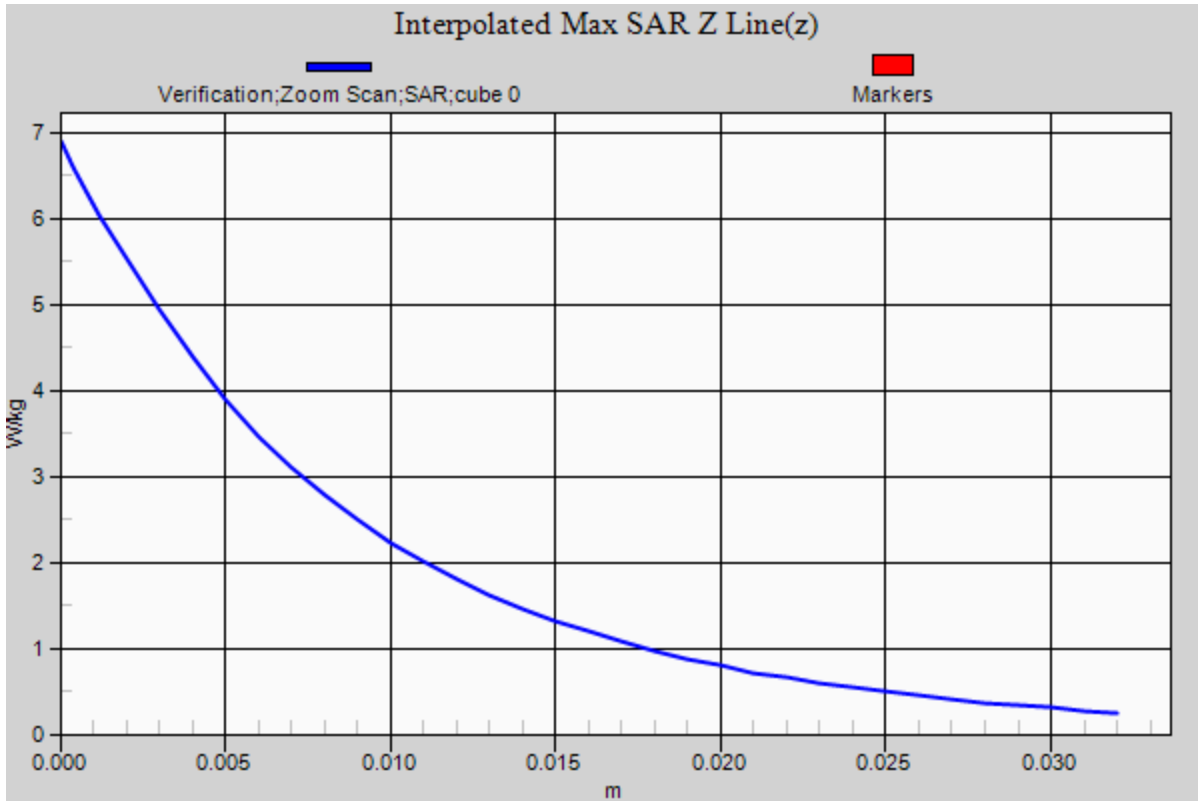

RF Exposure Lab

Plot 5

DUT: Dipole 1750 MHz D1750V2; Type: D1750V2; Serial: D1750V2 - SN:1018

Communication System: CW; Frequency: 1750 MHz; Duty Cycle: 1:1
Medium: MSL1750; Medium parameters used: $f = 1750$ MHz; $\sigma = 1.56$ S/m; $\epsilon_r = 52.68$; $\rho = 1000$ kg/m³
Phantom section: Flat Section

Test Date: Date: 3/6/2019; Ambient Temp: 23 °C; Tissue Temp: 21 °C

Probe: EX3DV4 - SN3662; ConvF(7.96, 7.96, 7.96); Calibrated: 4/20/2018;
Sensor-Surface: 2mm (Mechanical Surface Detection)
Electronics: DAE4 Sn1321; Calibrated: 1/10/2019
Phantom: ELI v5.0; Type: QDOVA002AA; Serial: 2037
Measurement SW: DASY52, Version 52.10 (0); SEMCAD X Version 14.6.10 (7417)

Procedure Notes:

1750 MHz/Verification/Area Scan (5x7x1): Measurement grid: dx=15mm, dy=15mm
Maximum value of SAR (measured) = 5.33 W/kg

1750 MHz/Verification/Zoom Scan (5x5x7)/Cube 0: Measurement grid: dx=8mm, dy=8mm, dz=5mm
Reference Value = 31.227 V/m; Power Drift = -0.01 dB
Peak SAR (extrapolated) = 6.89 W/kg
SAR(1 g) = 3.65 W/kg; SAR(10 g) = 2.03 W/kg
Maximum value of SAR (measured) = 5.49 W/kg

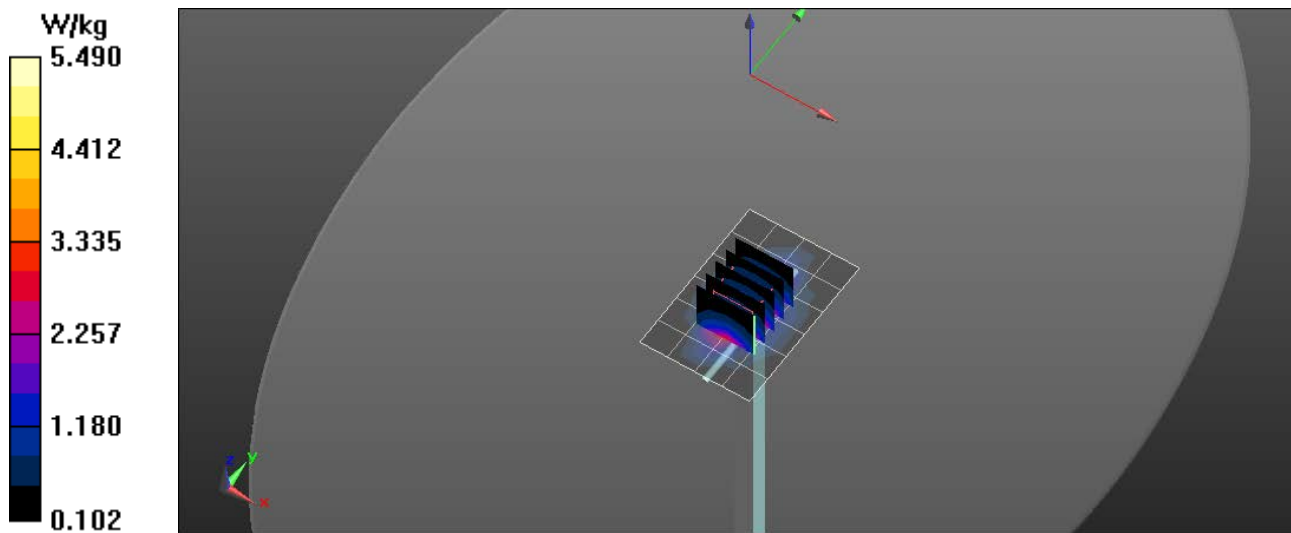

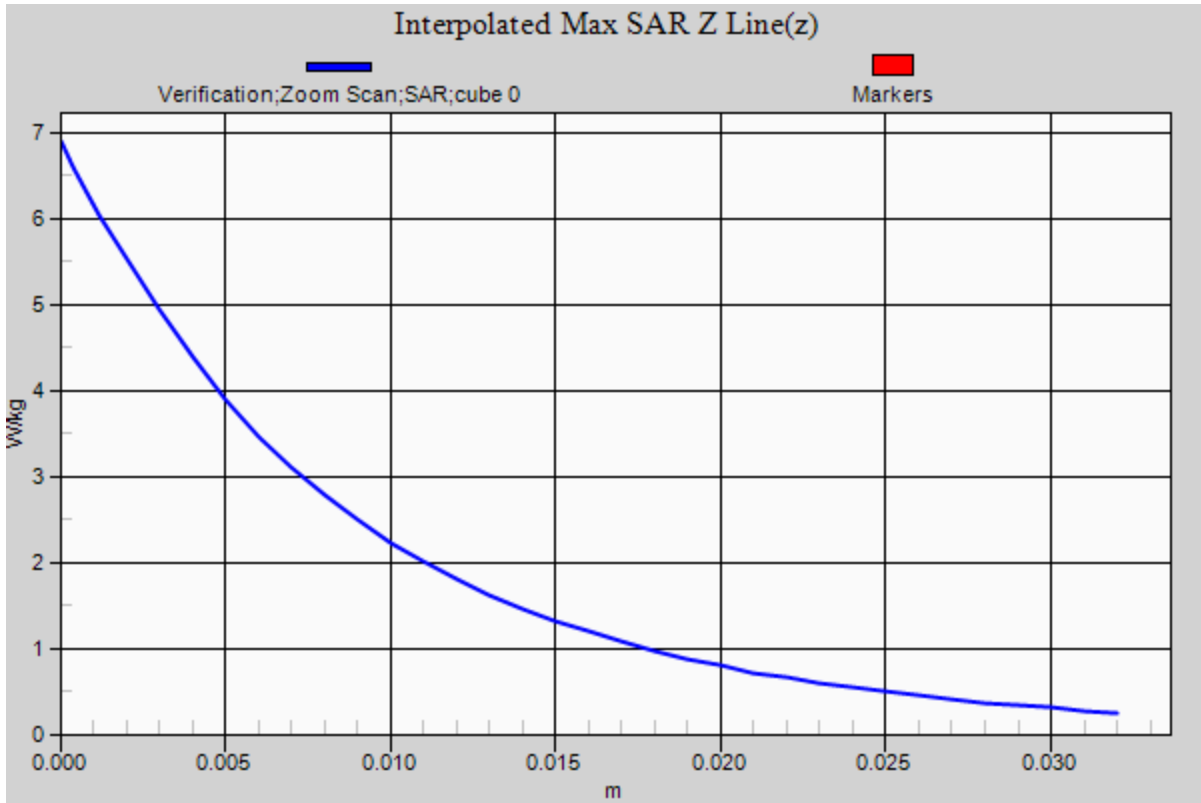

RF Exposure Lab

Plot 6

DUT: Dipole 1900 MHz D1900V2; Type: D1900V2; Serial: D1900V2 - SN:5d116

Communication System: CW; Frequency: 1900 MHz; Duty Cycle: 1:1
Medium: MSL1900; Medium parameters used: $f = 1900$ MHz; $\sigma = 1.58$ S/m; $\epsilon_r = 52.97$; $\rho = 1000$ kg/m³
Phantom section: Flat Section

Test Date: Date: 2/11/2019; Ambient Temp: 23 °C; Tissue Temp: 21 °C

Probe: EX3DV4 - SN3662; ConvF(7.61, 7.61, 7.61); Calibrated: 4/20/2018;
Sensor-Surface: 2mm (Mechanical Surface Detection)
Electronics: DAE4 Sn1321; Calibrated: 1/10/2019
Phantom: ELI v5.0; Type: QDOVA002AA; Serial: 2037
Measurement SW: DASY52, Version 52.10 (0); SEMCAD X Version 14.6.10 (7417)

Procedure Notes:

1900 MHz/Verification/Area Scan (5x7x1): Measurement grid: dx=15mm, dy=15mm
Maximum value of SAR (measured) = 5.52 W/kg

1900 MHz/Verification/Zoom Scan (5x5x7)/Cube 0: Measurement grid: dx=8mm, dy=8mm, dz=5mm
Reference Value = 33.856 V/m; Power Drift = -0.02 dB
Peak SAR (extrapolated) = 7.25 W/kg
SAR(1 g) = 4.01 W/kg; SAR(10 g) = 2.05 W/kg
Maximum value of SAR (measured) = 5.76 W/kg

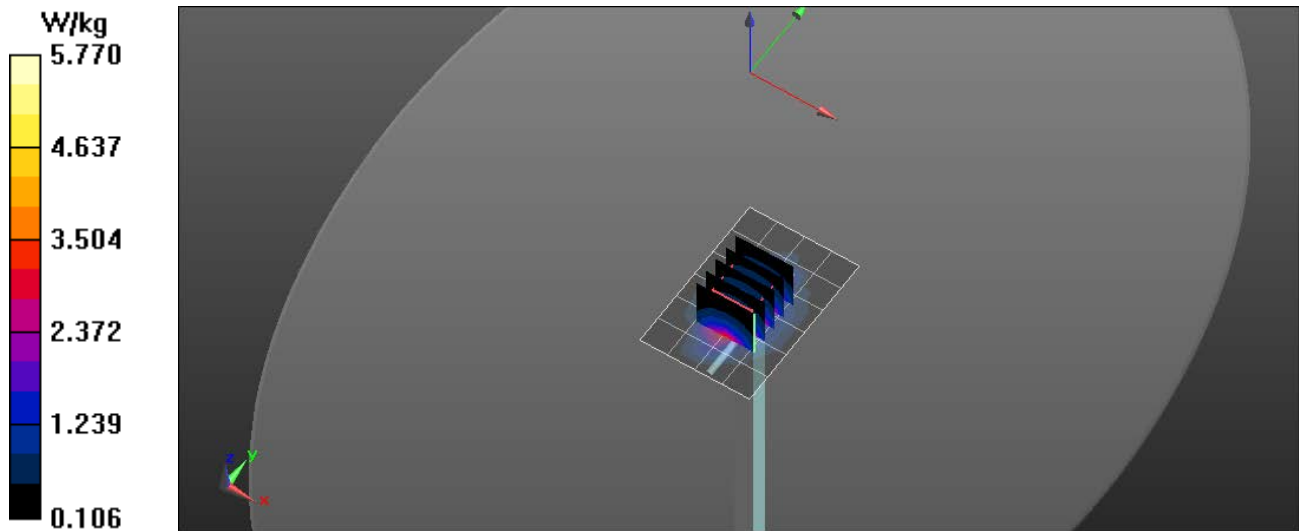

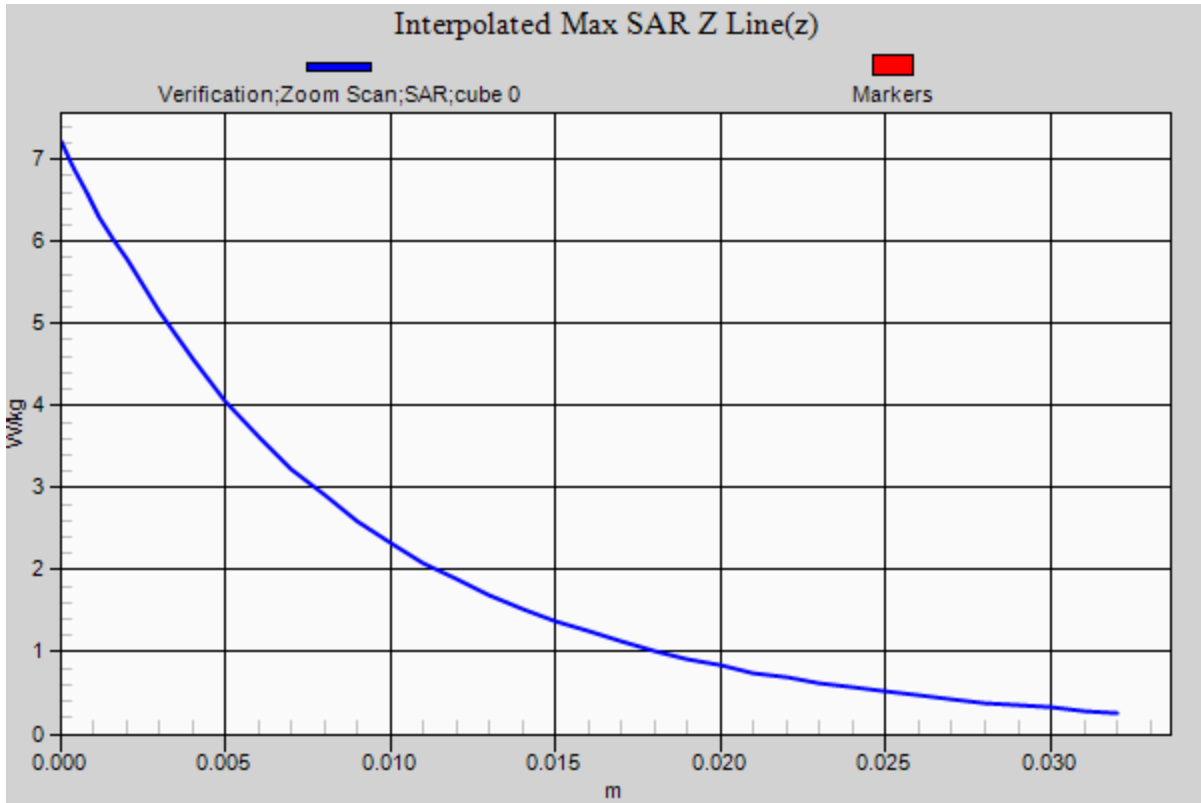

RF Exposure Lab

Plot 7

DUT: Dipole 1900 MHz D1900V2; Type: D1900V2; Serial: D1900V2 - SN:5d116

Communication System: CW; Frequency: 1900 MHz; Duty Cycle: 1:1
 Medium: MSL1900; Medium parameters used: $f = 1900$ MHz; $\sigma = 1.54$ S/m; $\epsilon_r = 53.17$; $\rho = 1000$ kg/m³
 Phantom section: Flat Section

Test Date: Date: 3/4/2019; Ambient Temp: 23 °C; Tissue Temp: 21 °C

Probe: EX3DV4 - SN3662; ConvF(7.61, 7.61, 7.61); Calibrated: 4/20/2018;
 Sensor-Surface: 2mm (Mechanical Surface Detection)
 Electronics: DAE4 Sn1321; Calibrated: 1/10/2019
 Phantom: ELI v5.0; Type: QDOVA002AA; Serial: 2037
 Measurement SW: DASY52, Version 52.10 (0); SEMCAD X Version 14.6.10 (7417)

Procedure Notes:

1900 MHz/Verification/Area Scan (5x7x1): Measurement grid: dx=15mm, dy=15mm
 Maximum value of SAR (measured) = 5.44 W/kg

1900 MHz/Verification/Zoom Scan (5x5x7)/Cube 0: Measurement grid: dx=8mm, dy=8mm, dz=5mm
 Reference Value = 31.227 V/m; Power Drift = -0.01 dB
 Peak SAR (extrapolated) = 7.22 W/kg
SAR(1 g) = 4.02 W/kg; SAR(10 g) = 2.1 W/kg
 Maximum value of SAR (measured) = 5.77 W/kg

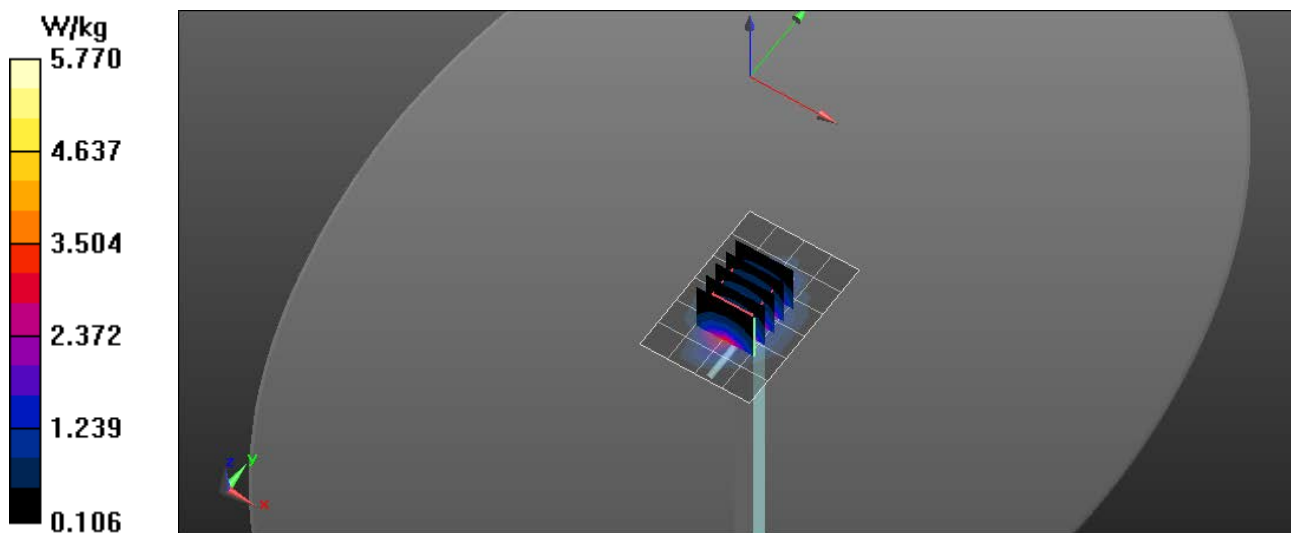

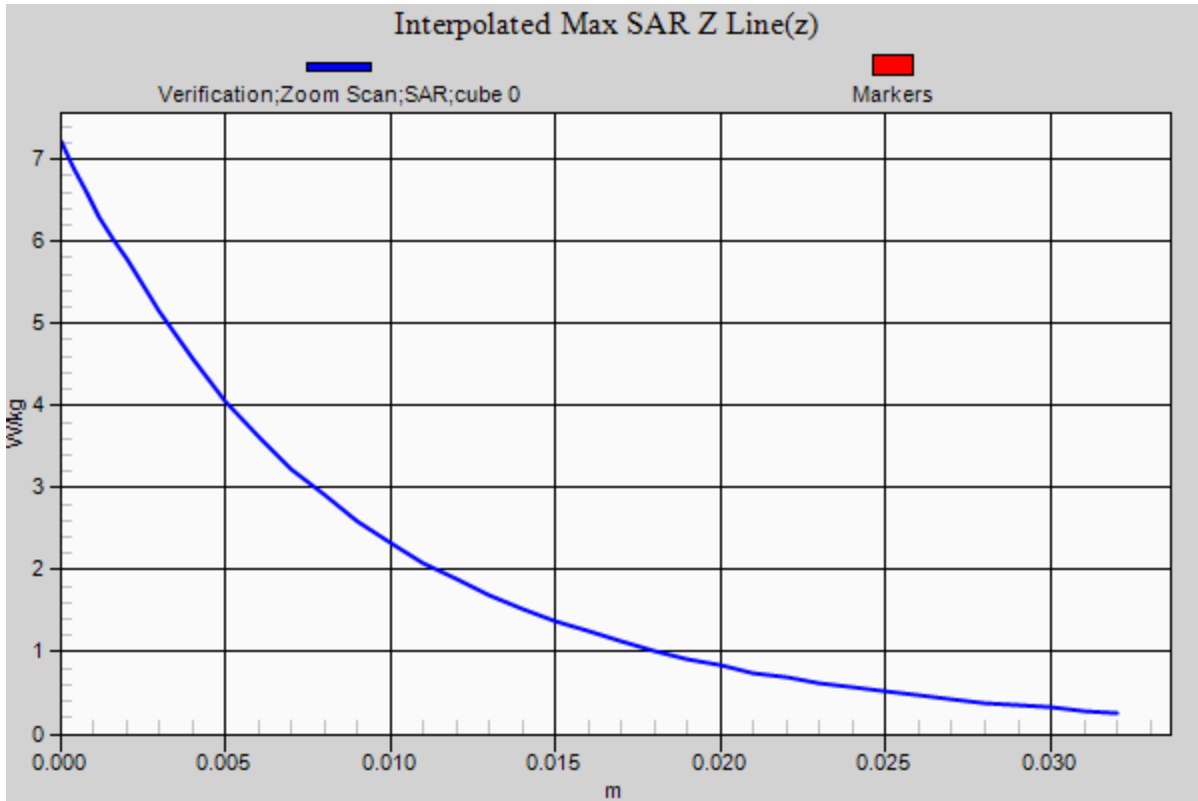

RF Exposure Lab

Plot 8

DUT: Dipole 2450 MHz D2450V2; Type: D2450V2; Serial: D2450V2 - SN: 829

Communication System: CW; Frequency: 2450 MHz; Duty Cycle: 1:1
Medium: MSL2450; Medium parameters used: $f = 2450$ MHz; $\sigma = 2$ S/m; $\epsilon_r = 52.58$; $\rho = 1000$ kg/m³
Phantom section: Flat Section

Test Date: Date: 3/13/2019; Ambient Temp: 23 °C; Tissue Temp: 21 °C
Probe: EX3DV4 - SN3662; ConvF(7.29, 7.29, 7.29); Calibrated: 4/20/2018;
Sensor-Surface: 2mm (Mechanical Surface Detection)
Electronics: DAE4 Sn1321; Calibrated: 1/10/2019
Phantom: ELI v5.0; Type: QDOVA002AA; Serial: 2037
Measurement SW: DASY52, Version 52.10 (0); SEMCAD X Version 14.6.10 (7417)

Procedure Notes:

Body Verification/2450 MHz/Area Scan (61x101x1): Interpolated grid: dx=1.200 mm, dy=1.200 mm
Maximum value of SAR (interpolated) = 8.92 W/kg

Body Verification/2450 MHz/Zoom Scan (7x7x7)/Cube 0: Measurement grid: dx=5mm, dy=5mm, dz=5mm
Reference Value = 53.359 V/m; Power Drift = -0.02 dB
Peak SAR (extrapolated) = 11.04 W/kg
SAR(1 g) = 5.12 W/kg; SAR(10 g) = 2.37 W/kg
Maximum value of SAR (measured) = 8.79 W/kg

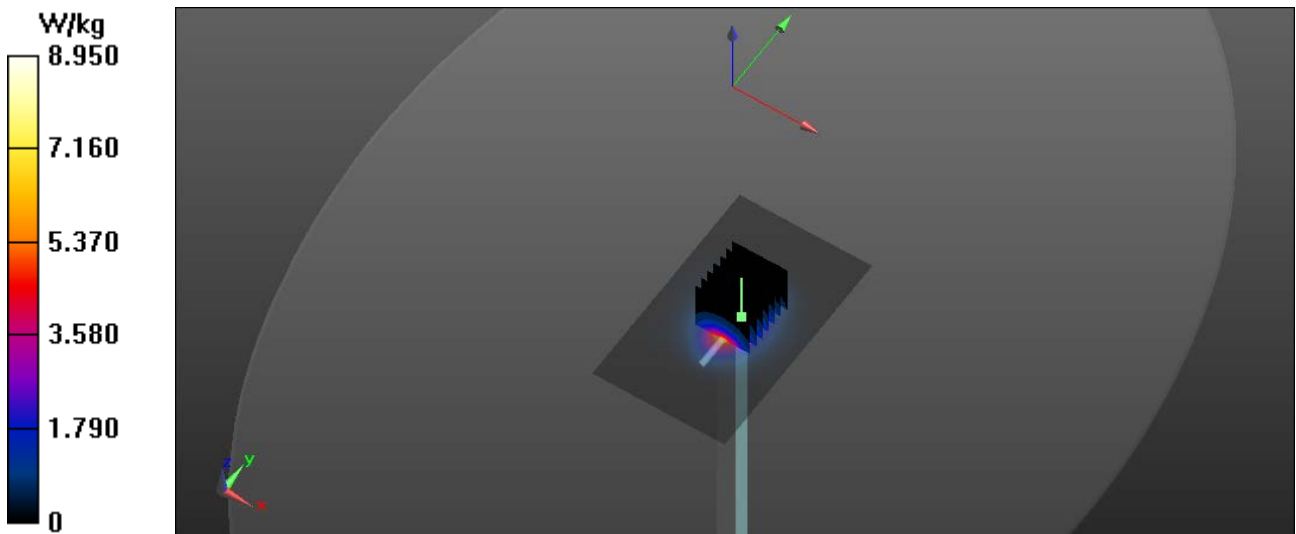

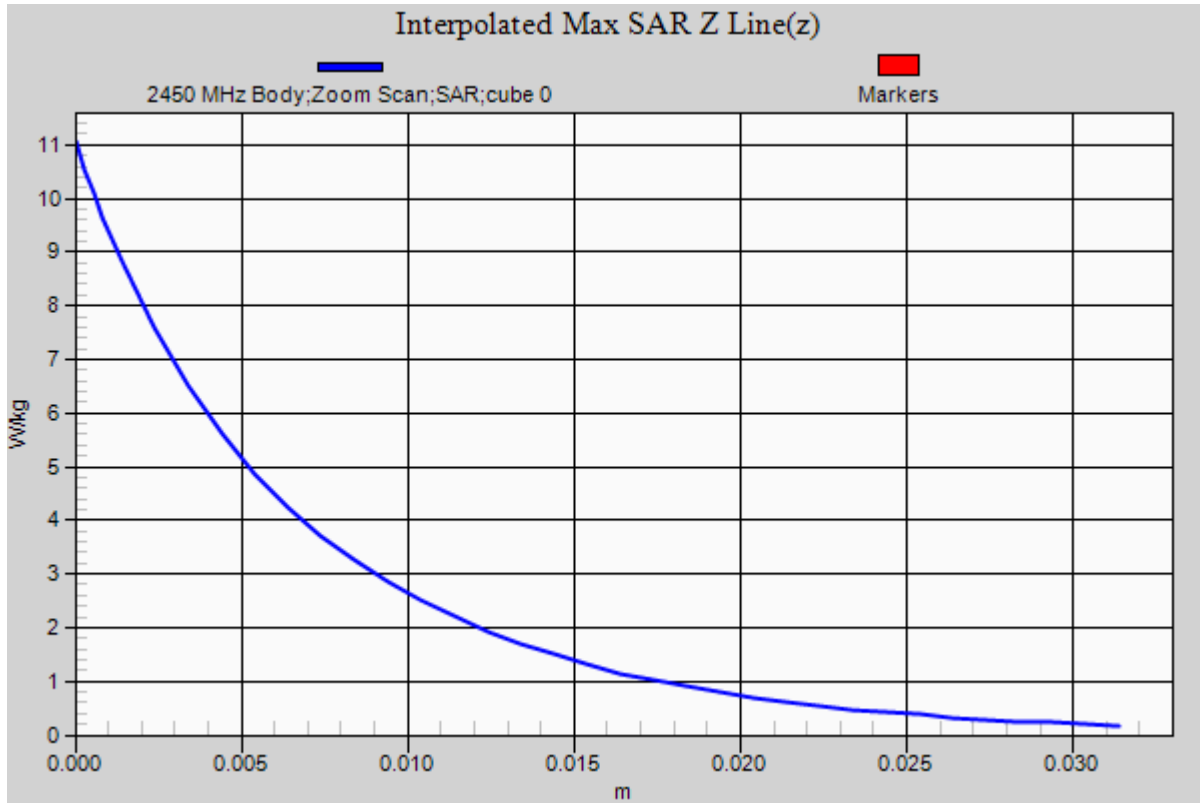

RF Exposure Lab

Plot 9

DUT: Dipole D3500V2; Type: D3500V2; Serial: D3500V2 - SN:1061

Communication System: CW; Frequency: 3500 MHz; Duty Cycle: 1:1
 Medium: MSL 3-6 GHz; Medium parameters used: $f = 3500$ MHz; $\sigma = 3.34$ S/m; $\epsilon_r = 51.11$; $\rho = 1000$ kg/m³
 Phantom section: Flat Section

Test Date: Date: 3/9/2019; Ambient Temp: 23 °C; Tissue Temp: 21 °C
 Probe: EX3DV4 - SN3662; ConvF(7, 7, 7); Calibrated: 4/20/2018;
 Sensor-Surface: 2mm (Mechanical Surface Detection)
 Electronics: DAE4 Sn1321; Calibrated: 1/10/2019
 Phantom: ELI v5.0; Type: QDOVA002AA; Serial: 2037
 Measurement SW: DASY52, Version 52.10 (0); SEMCAD X Version 14.6.10 (7417)

Procedure Notes:

3500 MHz Body/Verification/Area Scan (7x9x1): Measurement grid: dx=10mm, dy=10mm
 Maximum value of SAR (measured) = 1.64 W/kg

3500 MHz Body/Verification/Zoom Scan (7x7x7)/Cube 0: Measurement grid: dx=4mm, dy=4mm, dz=4mm
 Reference Value = 11.892 V/m; Power Drift = 0.01 dB
 Peak SAR (extrapolated) = 3.63 W/kg
SAR(1 g) = 0.655 W/kg; SAR(10 g) = 0.245 W/kg
 Maximum value of SAR (measured) = 1.70 W/kg

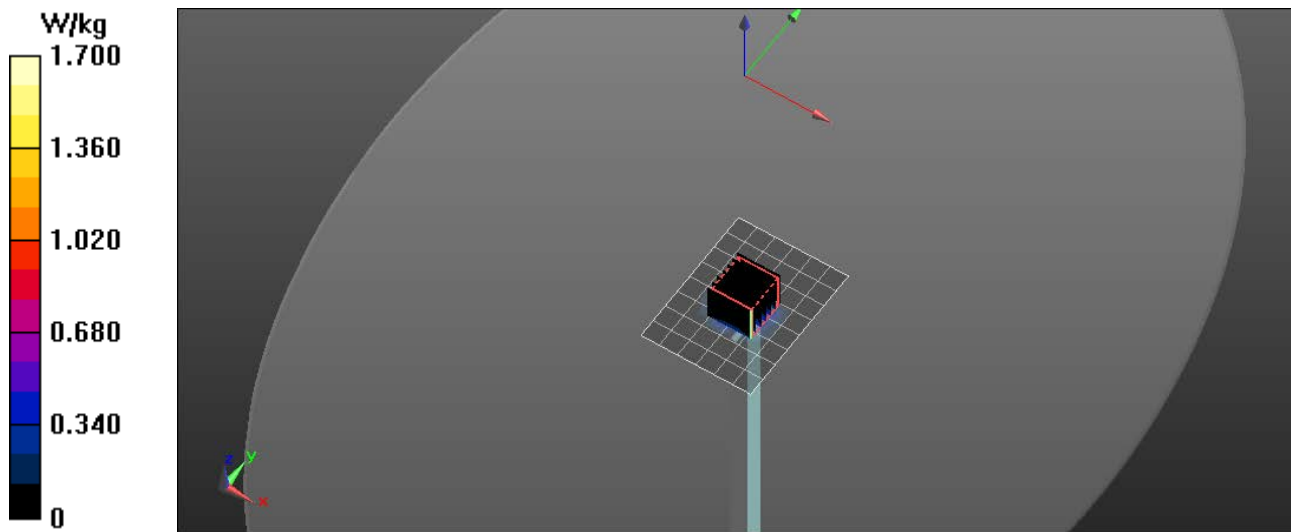

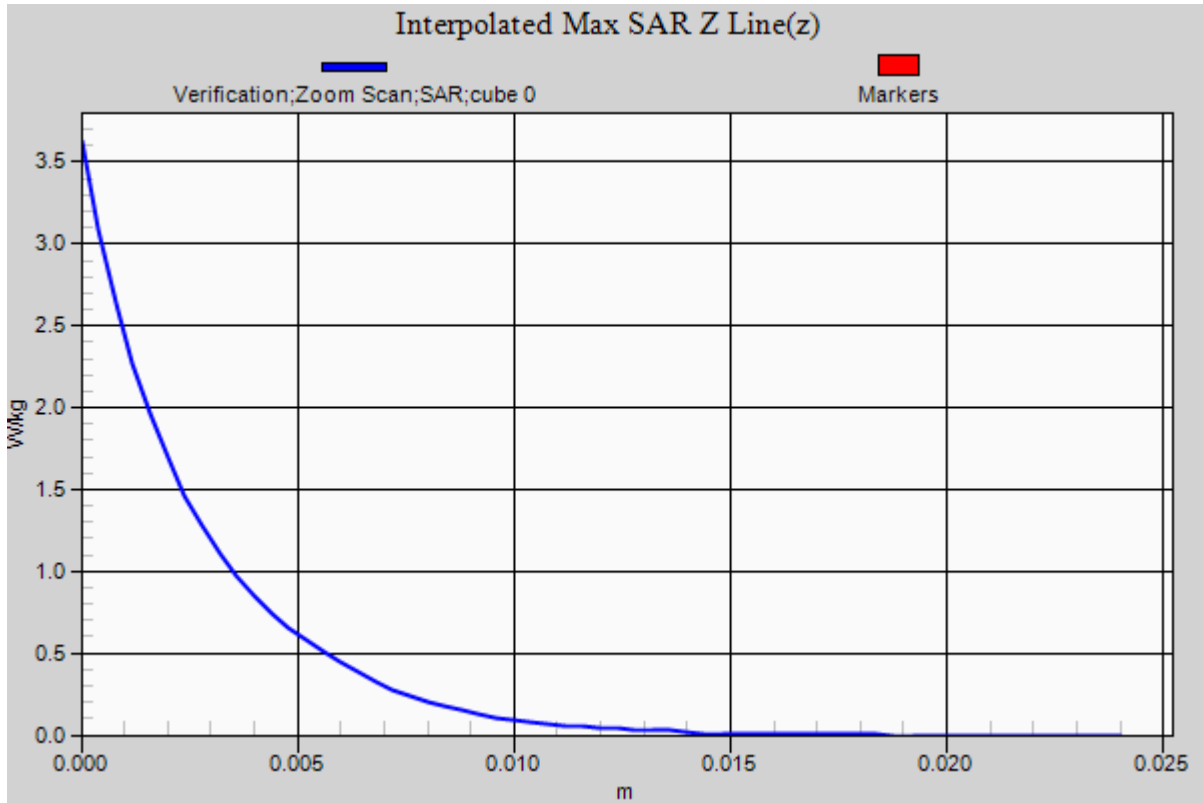

RF Exposure Lab

Plot 10

DUT: Dipole D3700V2; Type: D3700V2; Serial: D3700V2 - SN:1024

Communication System: CW; Frequency: 3700 MHz; Duty Cycle: 1:1
 Medium: MSL 3-6 GHz; Medium parameters used: $f = 3700$ MHz; $\sigma = 3.54$ S/m; $\epsilon_r = 50.86$; $\rho = 1000$ kg/m³
 Phantom section: Flat Section

Test Date: Date: 3/9/2019; Ambient Temp: 23 °C; Tissue Temp: 21 °C
 Probe: EX3DV4 - SN3662; ConvF(6.71, 6.71, 6.71); Calibrated: 4/20/2018;
 Sensor-Surface: 2mm (Mechanical Surface Detection)
 Electronics: DAE4 Sn1321; Calibrated: 1/10/2019
 Phantom: ELI v5.0; Type: QDOVA002AA; Serial: 2037
 Measurement SW: DASY52, Version 52.10 (0); SEMCAD X Version 14.6.10 (7417)

Procedure Notes:

3700 MHz Body/Verification/Area Scan (61x81x1): Interpolated grid: dx=1.000 mm, dy=1.000 mm
 Maximum value of SAR (interpolated) = 1.55 W/kg

3700 MHz Body/Verification/Zoom Scan (7x7x7)/Cube 0: Measurement grid: dx=4mm, dy=4mm, dz=4mm
 Reference Value = 55.759 V/m; Power Drift = -0.04 dB
 Peak SAR (extrapolated) = 3.09 W/kg
SAR(1 g) = 0.659 W/kg; SAR(10 g) = 0.238 W/kg
 Maximum value of SAR (measured) = 1.58 W/kg

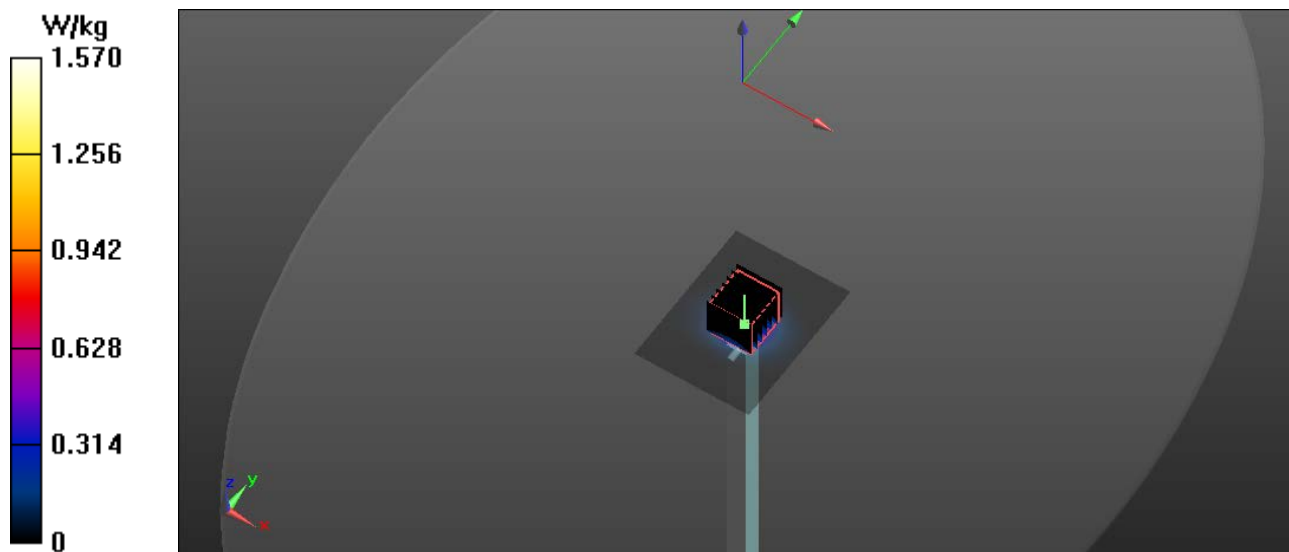

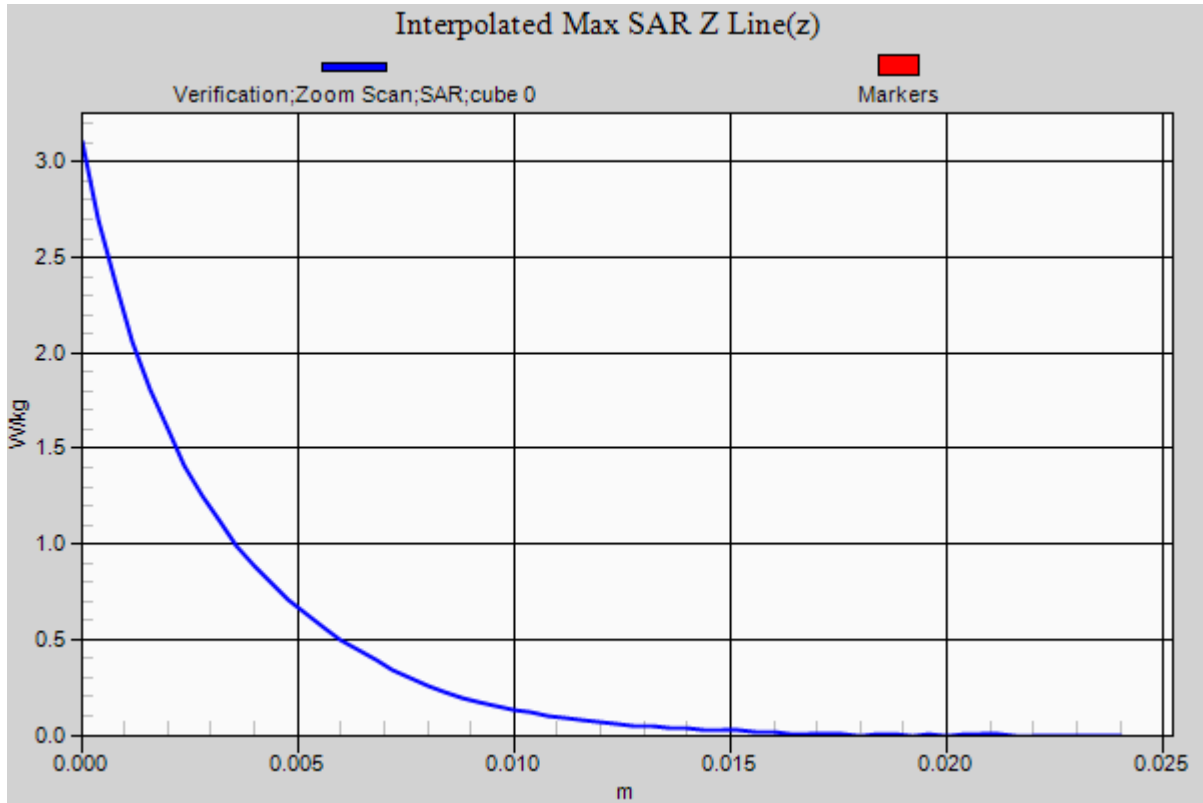

RF Exposure Lab

Plot 11

DUT: Dipole D5GHzV2; Type: D5GHzV2; Serial: D5GHzV2 - SN:1085

Communication System: CW; Frequency: 5250 MHz; Duty Cycle: 1:1
 Medium: MSL 3-6 GHz; Medium parameters used (interpolated): $f = 5250$ MHz; $\sigma = 5.395$ S/m; $\epsilon_r = 48.875$; $\rho = 1000$ kg/m³
 Phantom section: Flat Section

Test Date: Date: 3/11/2019; Ambient Temp: 23 °C; Tissue Temp: 21 °C
 Probe: EX3DV4 - SN3662; ConvF(4.46, 4.46, 4.46); Calibrated: 4/20/2018;
 Sensor-Surface: 2mm (Mechanical Surface Detection)
 Electronics: DAE4 Sn1321; Calibrated: 1/10/2019
 Phantom: ELI v5.0; Type: QDOVA002AA; Serial: 2037
 Measurement SW: DASY52, Version 52.10 (0); SEMCAD X Version 14.6.10 (7417)

Procedure Notes:

5250 MHz Body/Verification/Area Scan (7x9x1): Measurement grid: dx=10mm, dy=10mm

[Info: Interpolated medium parameters used for SAR evaluation.](#)

Maximum value of SAR (measured) = 1.58 W/kg

5250 MHz Body/Verification/Zoom Scan (7x7x12)/Cube 0: Measurement grid: dx=4mm, dy=4mm, dz=2mm

Reference Value = 11.705 V/m; Power Drift = 0.01 dB

Peak SAR (extrapolated) = 3.75 W/kg

SAR(1 g) = 0.763 W/kg; SAR(10 g) = 0.211 W/kg

[Info: Interpolated medium parameters used for SAR evaluation.](#)

Maximum value of SAR (measured) = 1.65 W/kg

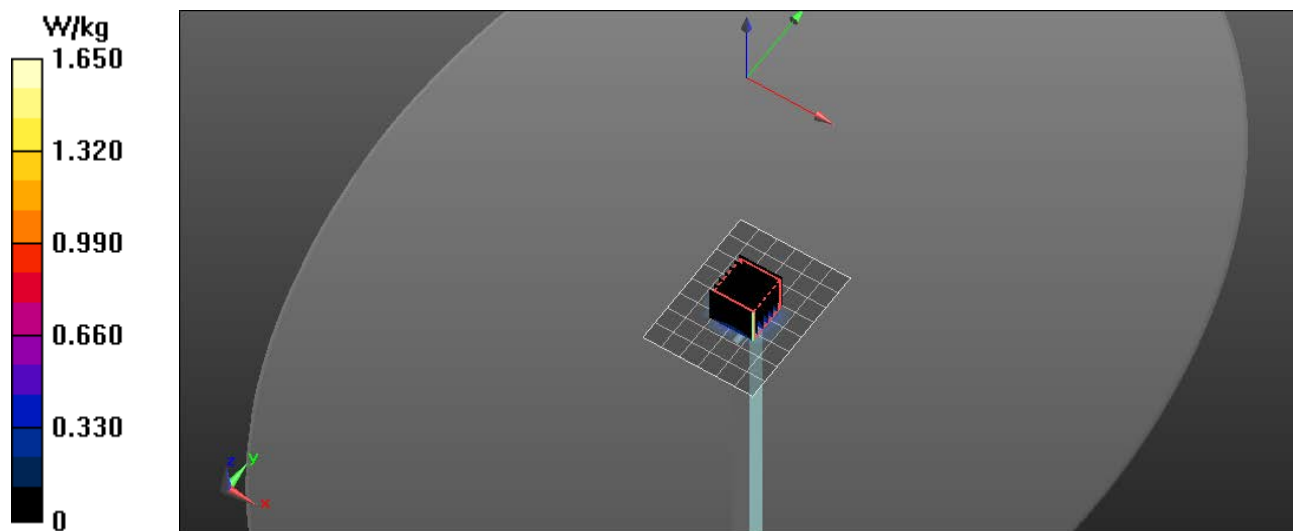

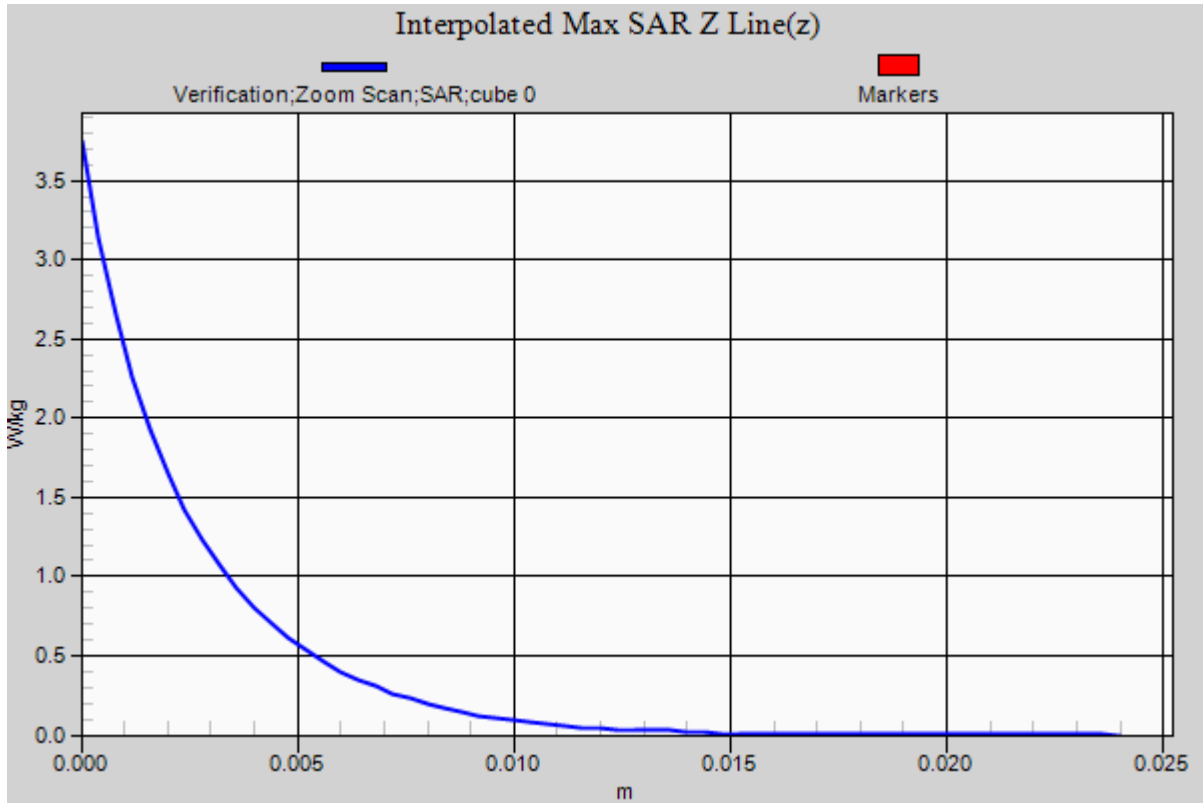

RF Exposure Lab

Plot 12

DUT: Dipole D5GHzV2; Type: D5GHzV2; Serial: D5GHzV2 - SN:1085

Communication System: CW; Frequency: 5750 MHz; Duty Cycle: 1:1
 Medium: MSL 3-6 GHz; Medium parameters used (interpolated): $f = 5750$ MHz; $\sigma = 5.985$ S/m; $\epsilon_r = 48.135$; $\rho = 1000$ kg/m³
 Phantom section: Flat Section

Test Date: Date: 3/11/2019; Ambient Temp: 23 °C; Tissue Temp: 21 °C
 Probe: EX3DV4 - SN3662; ConvF(4.08, 4.08, 4.08); Calibrated: 4/20/2018;
 Sensor-Surface: 2mm (Mechanical Surface Detection)
 Electronics: DAE4 Sn1321; Calibrated: 1/10/2019
 Phantom: ELI v5.0; Type: QDOVA002AA; Serial: 2037
 Measurement SW: DASY52, Version 52.10 (0); SEMCAD X Version 14.6.10 (7417)

Procedure Notes:

5750 MHz Body/Verification/Area Scan (7x9x1): Measurement grid: dx=10mm, dy=10mm

[Info: Interpolated medium parameters used for SAR evaluation.](#)

Maximum value of SAR (measured) = 1.56 W/kg

5750 MHz Body/Verification/Zoom Scan (7x7x12)/Cube 0: Measurement grid: dx=4mm, dy=4mm, dz=2mm

Reference Value = 11.621 V/m; Power Drift = -0.01 dB

Peak SAR (extrapolated) = 3.47 W/kg

SAR(1 g) = 0.759 W/kg; SAR(10 g) = 0.208 W/kg

[Info: Interpolated medium parameters used for SAR evaluation.](#)

Maximum value of SAR (measured) = 1.63 W/kg

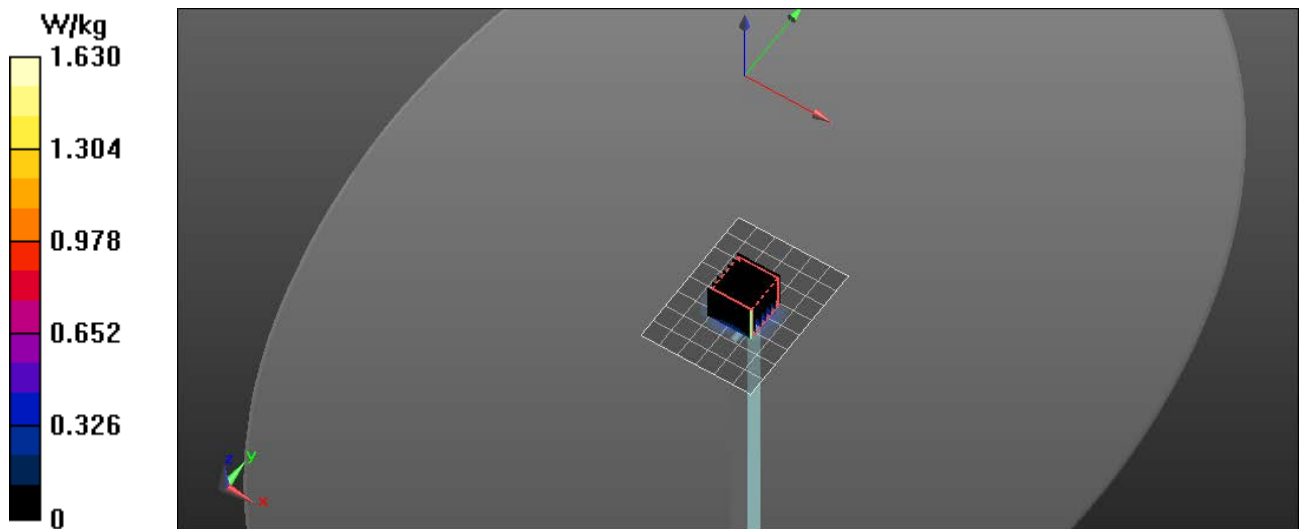

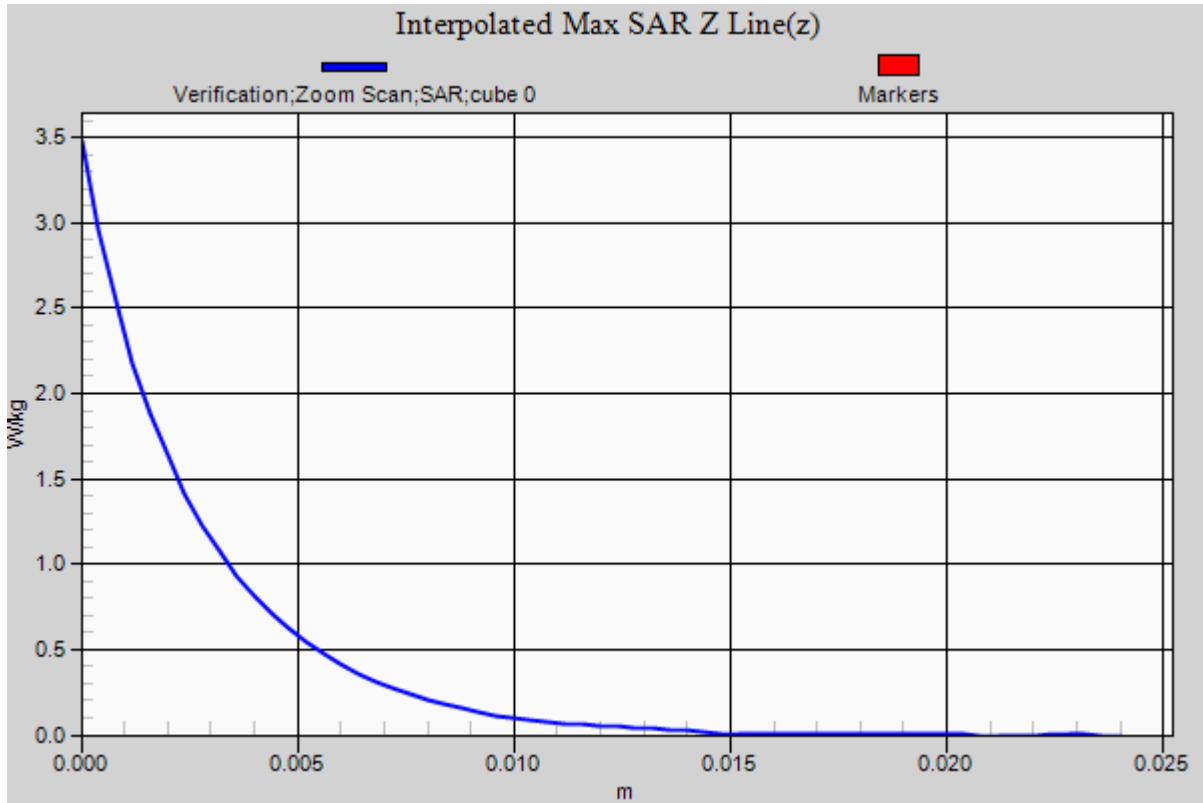

RF Exposure Lab

Plot 13

DUT: Dipole 750 MHz D750V3; Type: D750V3; Serial: D750V3 - SN:1016

Communication System: CW; Frequency: 750 MHz; Duty Cycle: 1:1
 Medium: MSL750; Medium parameters used: $f = 750 \text{ MHz}$; $\sigma = 0.99 \text{ S/m}$; $\epsilon_r = 55.57$; $\rho = 1000 \text{ kg/m}^3$
 Phantom section: Flat Section

Test Date: Date: 5/7/2019; Ambient Temp: 23 °C; Tissue Temp: 21 °C

Probe: EX3DV4 - SN3662; ConvF(9.57, 9.57, 9.57); Calibrated: 4/24/2019;
 Sensor-Surface: 2mm (Mechanical Surface Detection)
 Electronics: DAE4 Sn1321; Calibrated: 1/10/2018
 Phantom: ELI v5.0; Type: QDOVA002AA; Serial: 2037
 Measurement SW: DASY52, Version 52.10 (0); SEMCAD X Version 14.6.10 (7417)

Procedure Notes:

750 MHz/Verification/Area Scan (5x11x1): Measurement grid: dx=15mm, dy=15mm
 Maximum value of SAR (measured) = 1.08 W/kg

750 MHz/Verification/Zoom Scan (5x5x7)/Cube 0: Measurement grid: dx=8mm, dy=8mm, dz=5mm
 Reference Value = 31.227 V/m; Power Drift = 0.02 dB
 Peak SAR (extrapolated) = 1.30 W/kg
SAR(1 g) = 0.865 W/kg; SAR(10 g) = 0.569 W/kg
 Maximum value of SAR (measured) = 1.10 W/kg

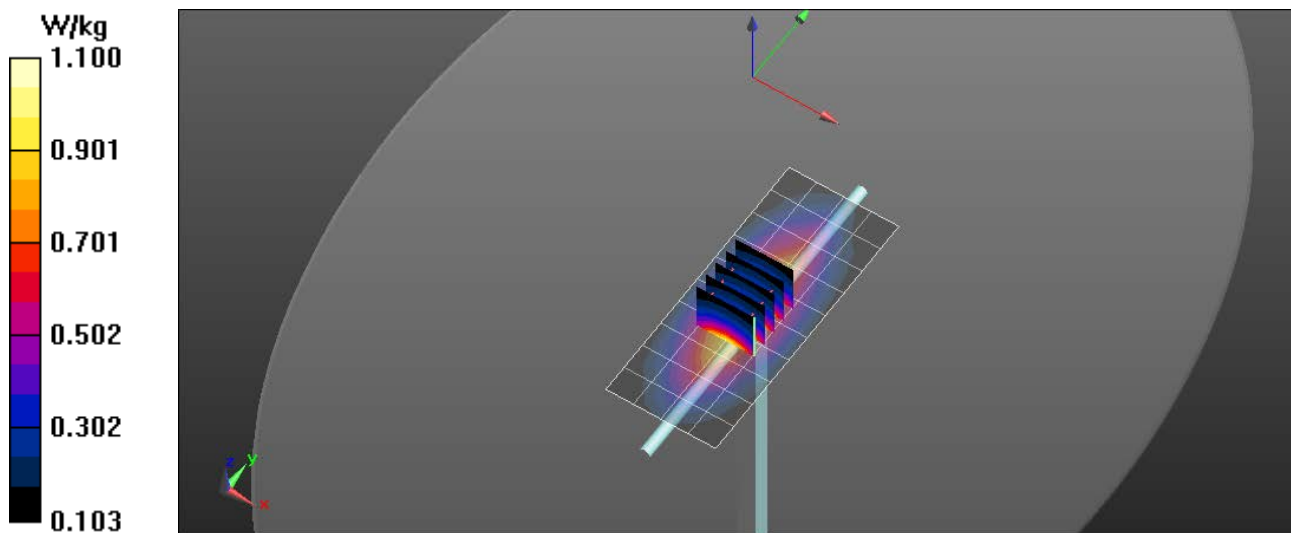

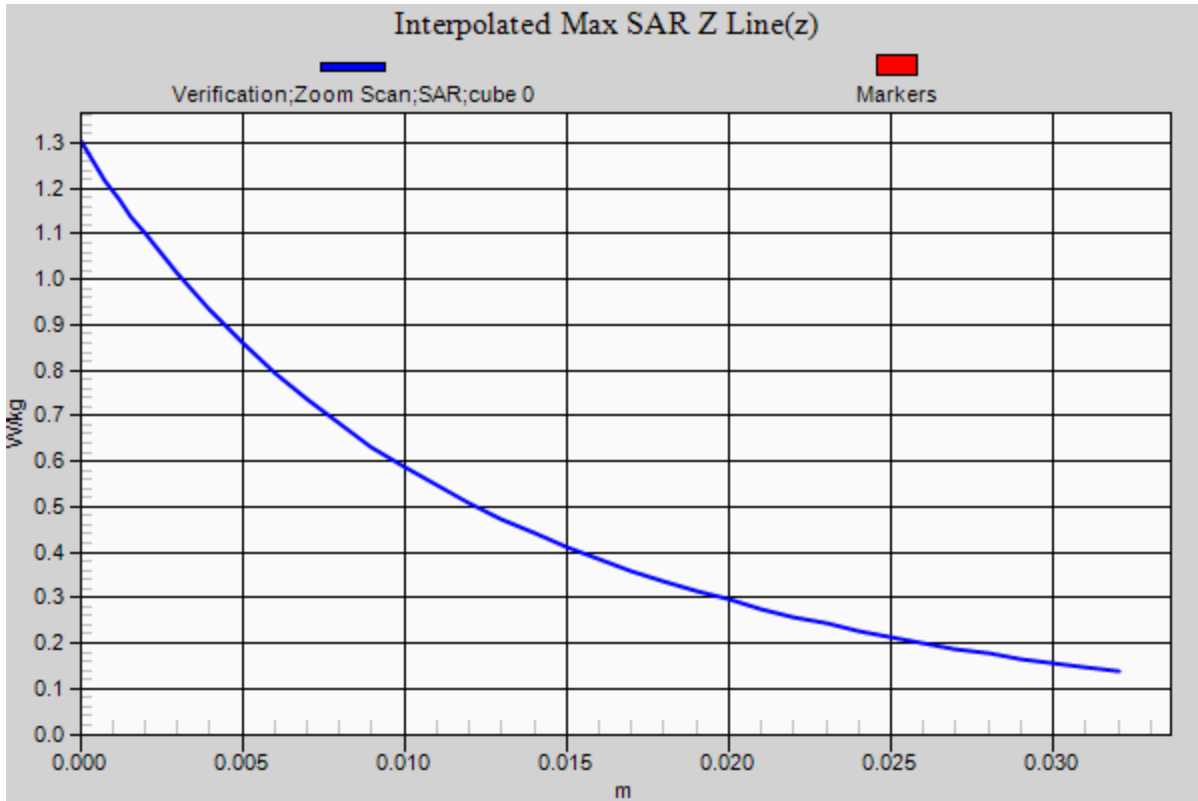

RF Exposure Lab

Plot 14

DUT: Dipole 835 MHz D835V2; Type: D835V2; Serial: D835V2 - SN:4d089

Communication System: CW; Frequency: 835 MHz; Duty Cycle: 1:1
Medium: MSL835; Medium parameters used: $f = 835 \text{ MHz}$; $\sigma = 0.99 \text{ S/m}$; $\epsilon_r = 55.91$; $\rho = 1000 \text{ kg/m}^3$
Phantom section: Flat Section

Test Date: Date: 5/7/2019; Ambient Temp: 23 °C; Tissue Temp: 21 °C
Probe: EX3DV4 - SN3662; ConvF(9.12, 9.12, 9.12); Calibrated: 4/24/2019;
Sensor-Surface: 2mm (Mechanical Surface Detection)
Electronics: DAE4 Sn1321; Calibrated: 1/10/2018
Phantom: ELI v5.0; Type: QDOVA002AA; Serial: 2037
Measurement SW: DASY52, Version 52.10 (0); SEMCAD X Version 14.6.10 (7417)

Procedure Notes:

835 MHz Body/Verification/Area Scan (81x161x1): Interpolated grid: $dx=1.000 \text{ mm}$, $dy=1.000 \text{ mm}$
Maximum value of SAR (interpolated) = 1.29 W/kg

835 MHz Body/Verification/Zoom Scan (5x5x7)/Cube 0: Measurement grid: $dx=8\text{mm}$, $dy=8\text{mm}$, $dz=5\text{mm}$
Reference Value = 52.612 V/m; Power Drift = -0.02 dB
Peak SAR (extrapolated) = 1.47 W/kg
SAR(1 g) = 0.953 W/kg; SAR(10 g) = 0.632 W/kg
Maximum value of SAR (measured) = 1.29 W/kg

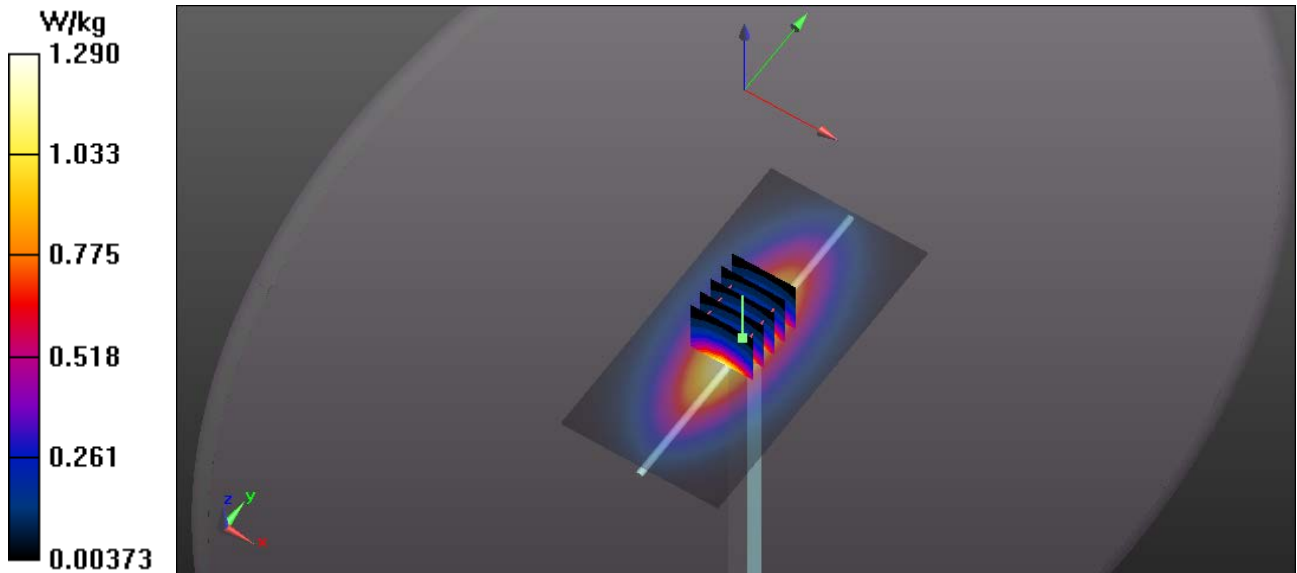

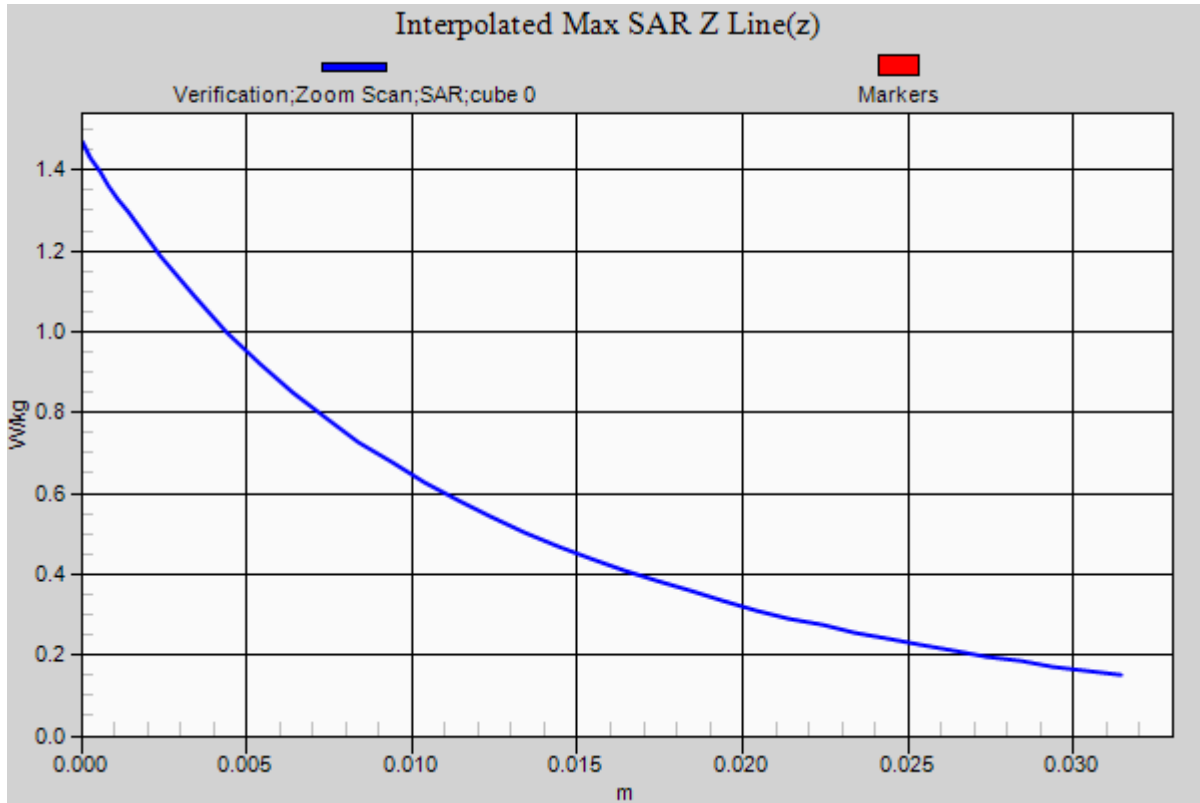

RF Exposure Lab

Plot 15

DUT: Dipole 1750 MHz D1750V2; Type: D1750V2; Serial: D1750V2 - SN:1018

Communication System: CW; Frequency: 1750 MHz; Duty Cycle: 1:1
 Medium: MSL1750; Medium parameters used: $f = 1750 \text{ MHz}$; $\sigma = 1.52 \text{ S/m}$; $\epsilon_r = 53.32$; $\rho = 1000 \text{ kg/m}^3$
 Phantom section: Flat Section

Test Date: Date: 5/7/2019; Ambient Temp: 23 °C; Tissue Temp: 21 °C

Probe: EX3DV4 - SN3662; ConvF(8.23, 8.23, 8.3); Calibrated: 4/24/2019;
 Sensor-Surface: 2mm (Mechanical Surface Detection)
 Electronics: DAE4 Sn1321; Calibrated: 1/10/2018
 Phantom: ELI v5.0; Type: QDOVA002AA; Serial: 2037
 Measurement SW: DASY52, Version 52.10 (0); SEMCAD X Version 14.6.10 (7417)

Procedure Notes:

1750 MHz/Verification/Area Scan (5x7x1): Measurement grid: dx=15mm, dy=15mm
 Maximum value of SAR (measured) = 5.33 W/kg

1750 MHz/Verification/Zoom Scan (5x5x7)/Cube 0: Measurement grid: dx=8mm, dy=8mm, dz=5mm
 Reference Value = 31.227 V/m; Power Drift = -0.01 dB
 Peak SAR (extrapolated) = 6.89 W/kg
SAR(1 g) = 3.68 W/kg; SAR(10 g) = 2.03 W/kg
 Maximum value of SAR (measured) = 5.49 W/kg

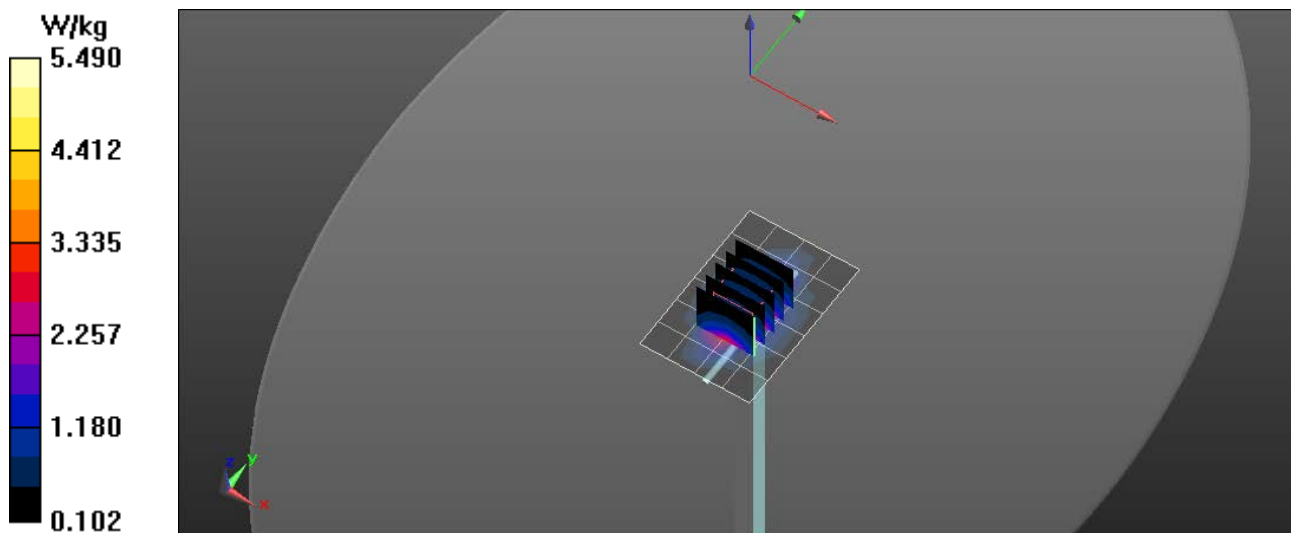

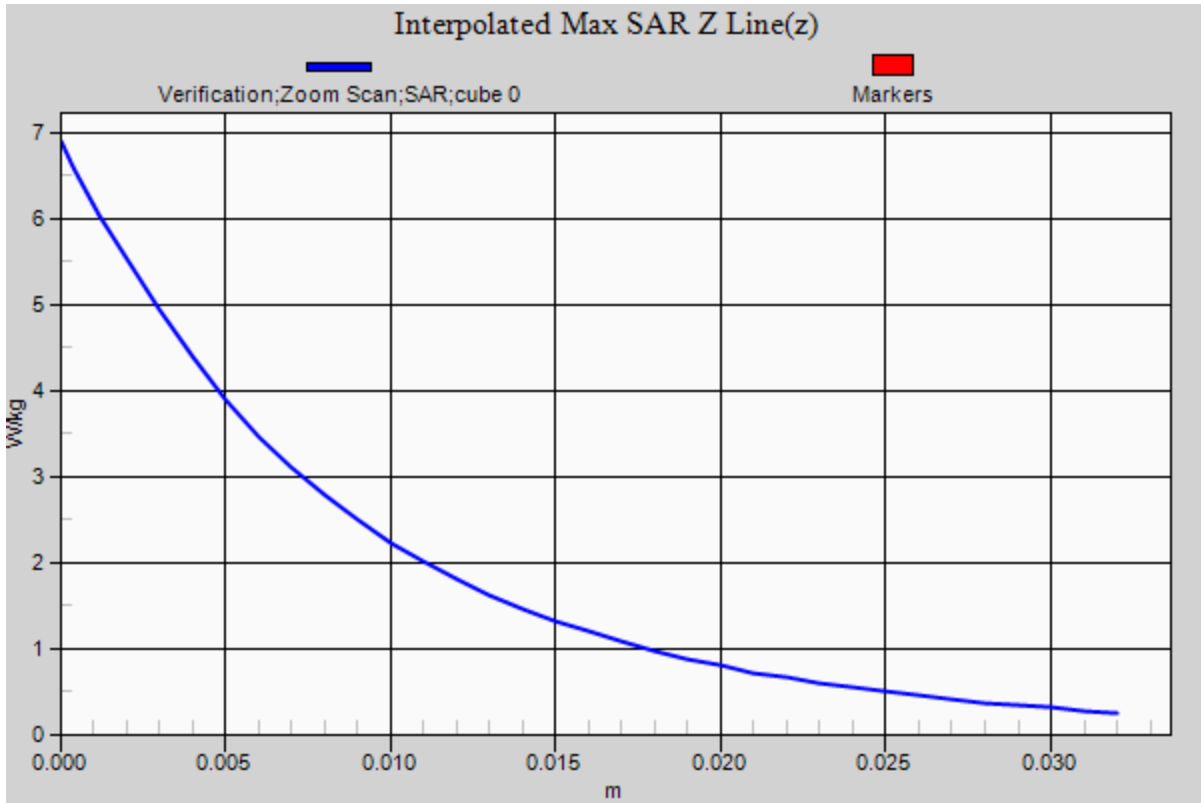

RF Exposure Lab

Plot 16

DUT: Dipole 1900 MHz D1900V2; Type: D1900V2; Serial: D1900V2 - SN:5d116

Communication System: CW; Frequency: 1900 MHz; Duty Cycle: 1:1
 Medium: MSL1900; Medium parameters used: $f = 1900 \text{ MHz}$; $\sigma = 1.47 \text{ S/m}$; $\epsilon_r = 52.07$; $\rho = 1000 \text{ kg/m}^3$
 Phantom section: Flat Section

Test Date: Date: 5/7/2019; Ambient Temp: 23 °C; Tissue Temp: 21 °C
 Probe: EX3DV4 - SN3662; ConvF(7.9, 7.9, 7.9); Calibrated: 4/24/2019;
 Sensor-Surface: 2mm (Mechanical Surface Detection)
 Electronics: DAE4 Sn1321; Calibrated: 1/10/2018
 Phantom: ELI v5.0; Type: QDOVA002AA; Serial: 2037
 Measurement SW: DASY52, Version 52.10 (0); SEMCAD X Version 14.6.10 (7417)

Procedure Notes:

1900 MHz Body/Verification/Area Scan (61x81x1): Interpolated grid: $dx=1.000 \text{ mm}$, $dy=1.000 \text{ mm}$
 Maximum value of SAR (interpolated) = 5.63 W/kg

1900 MHz Body/Verification/Zoom Scan (7x7x7)/Cube 0: Measurement grid: $dx=5\text{mm}$, $dy=5\text{mm}$, $dz=5\text{mm}$
 Reference Value = 52.612 V/m; Power Drift = -0.02 dB
 Peak SAR (extrapolated) = 6.68 W/kg
SAR(1 g) = 3.98 W/kg; SAR(10 g) = 1.92 W/kg
 Maximum value of SAR (measured) = 5.63 W/kg

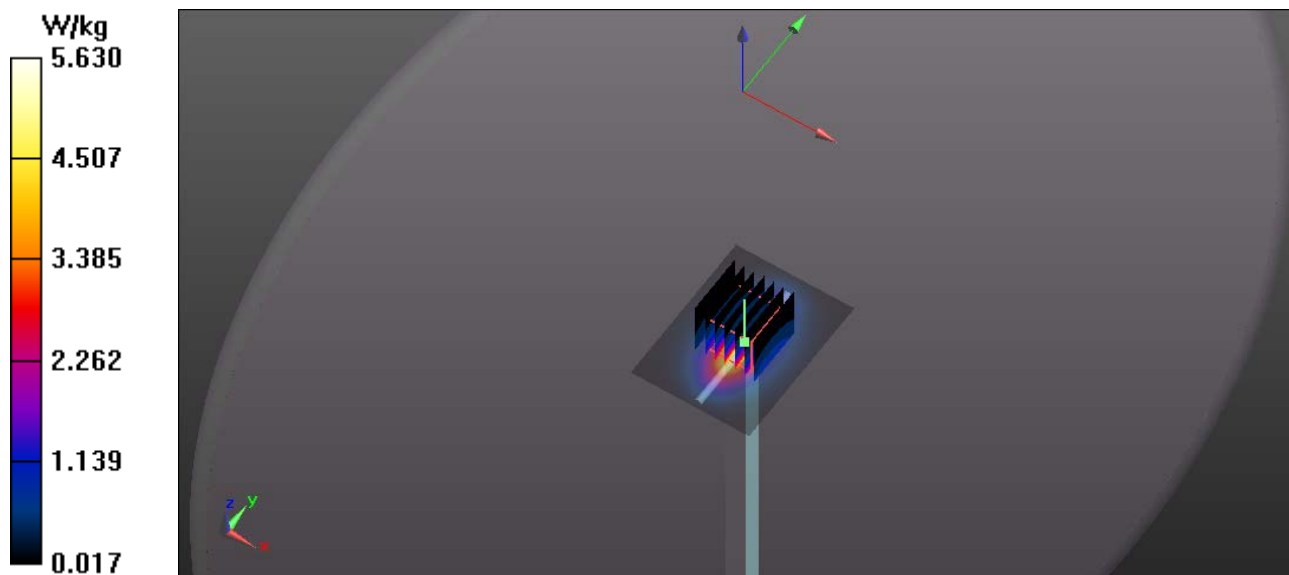

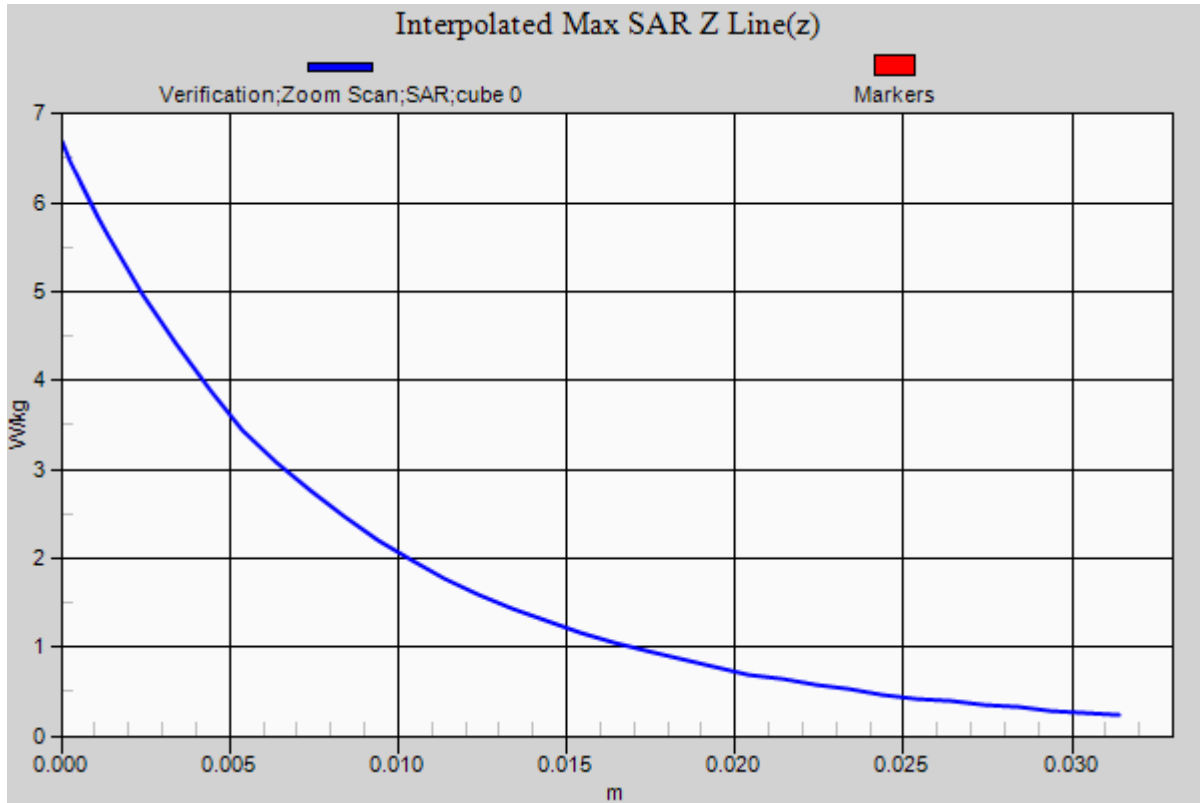

RF Exposure Lab

Plot 17

DUT: Dipole D3500V2; Type: D3500V2; Serial: D3500V2 - SN:1061

Communication System: CW; Frequency: 3500 MHz; Duty Cycle: 1:1
 Medium: MSL 3-6 GHz; Medium parameters used: $f = 3500$ MHz; $\sigma = 3.33$ S/m; $\epsilon_r = 50.93$; $\rho = 1000$ kg/m³
 Phantom section: Flat Section

Test Date: Date: 5/7/2019; Ambient Temp: 23 °C; Tissue Temp: 21 °C
 Probe: EX3DV4 - SN3662; ConvF(6.83, 6.83, 6.83); Calibrated: 4/24/2019;
 Sensor-Surface: 2mm (Mechanical Surface Detection)
 Electronics: DAE4 Sn1321; Calibrated: 1/10/2019
 Phantom: ELI v5.0; Type: QDOVA002AA; Serial: 2037
 Measurement SW: DASY52, Version 52.10 (0); SEMCAD X Version 14.6.10 (7417)

Procedure Notes:

3500 MHz Body/Verification/Area Scan (7x9x1): Measurement grid: dx=10mm, dy=10mm
 Maximum value of SAR (measured) = 1.67 W/kg

3500 MHz Body/Verification/Zoom Scan (7x7x7)/Cube 0: Measurement grid: dx=4mm, dy=4mm, dz=4mm
 Reference Value = 12.497 V/m; Power Drift = 0.02 dB
 Peak SAR (extrapolated) = 2.87 W/kg
SAR(1 g) = 0.657 W/kg; SAR(10 g) = 0.246 W/kg
 Maximum value of SAR (measured) = 1.78 W/kg

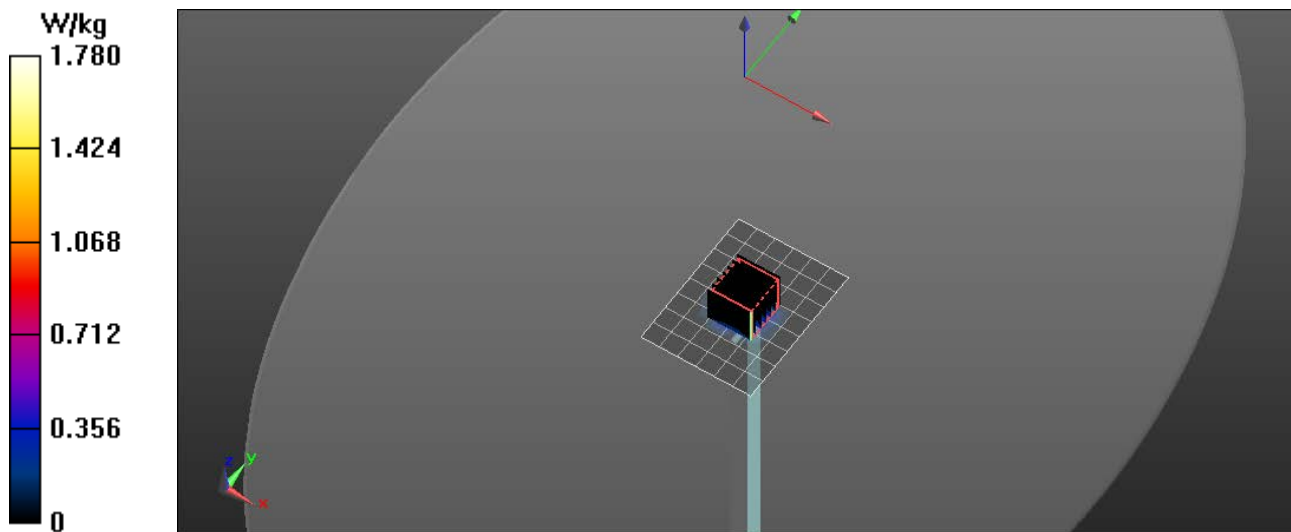

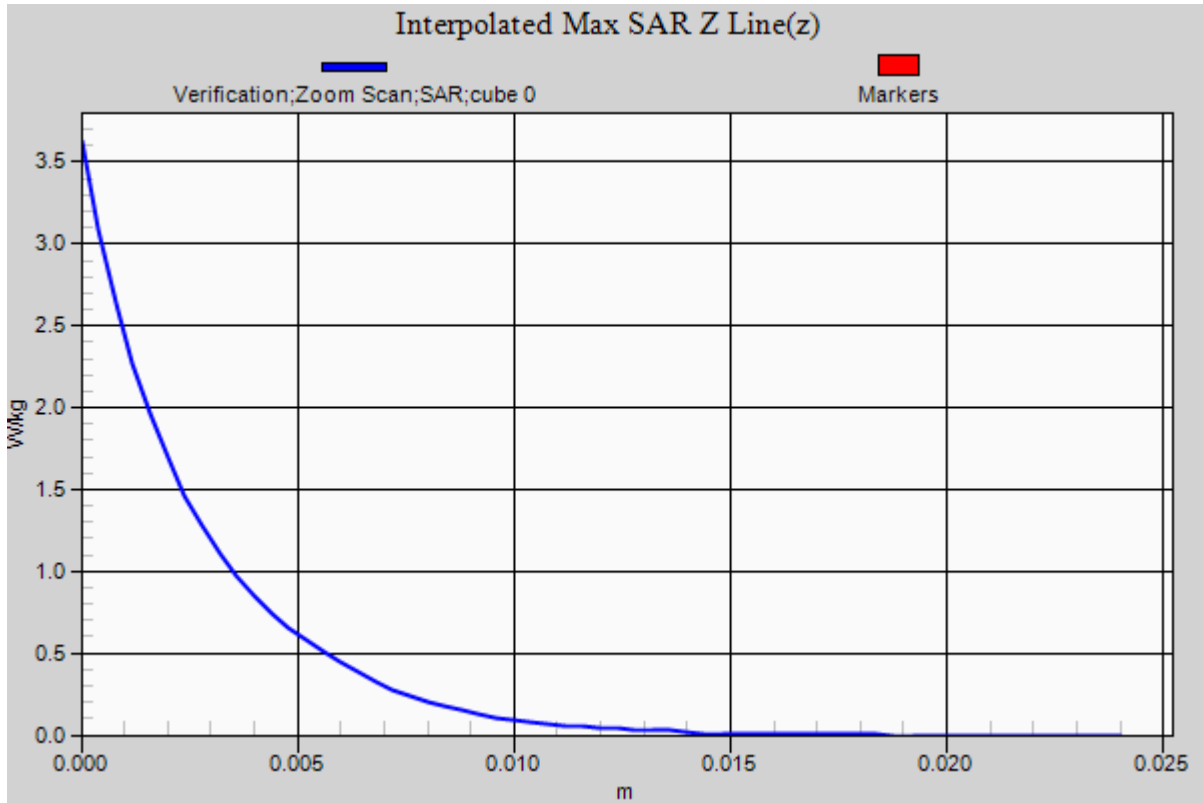

RF Exposure Lab

Plot 18

DUT: Dipole D3700V2; Type: D3700V2; Serial: D3700V2 - SN:1024

Communication System: CW; Frequency: 3700 MHz; Duty Cycle: 1:1
 Medium: MSL 3-6 GHz; Medium parameters used: $f = 3700$ MHz; $\sigma = 3.53$ S/m; $\epsilon_r = 50.68$; $\rho = 1000$ kg/m³
 Phantom section: Flat Section

Test Date: Date: 5/7/2019; Ambient Temp: 23 °C; Tissue Temp: 21 °C
 Probe: EX3DV4 - SN3662; ConvF(6.52, 6.52, 6.52); Calibrated: 4/24/2019;
 Sensor-Surface: 2mm (Mechanical Surface Detection)
 Electronics: DAE4 Sn1321; Calibrated: 1/10/2019
 Phantom: ELI v5.0; Type: QDOVA002AA; Serial: 2037
 Measurement SW: DASY52, Version 52.10 (0); SEMCAD X Version 14.6.10 (7417)

Procedure Notes:

3700 MHz Body/Verification/Area Scan (61x81x1): Interpolated grid: dx=1.000 mm, dy=1.000 mm
 Maximum value of SAR (interpolated) = 1.76 W/kg

3700 MHz Body/Verification/Zoom Scan (7x7x7)/Cube 0: Measurement grid: dx=4mm, dy=4mm, dz=4mm
 Reference Value = 13.429 V/m; Power Drift = -0.02 dB
 Peak SAR (extrapolated) = 3.04 W/kg
SAR(1 g) = 0.662 W/kg; SAR(10 g) = 0.239 W/kg
 Maximum value of SAR (measured) = 1.87 W/kg

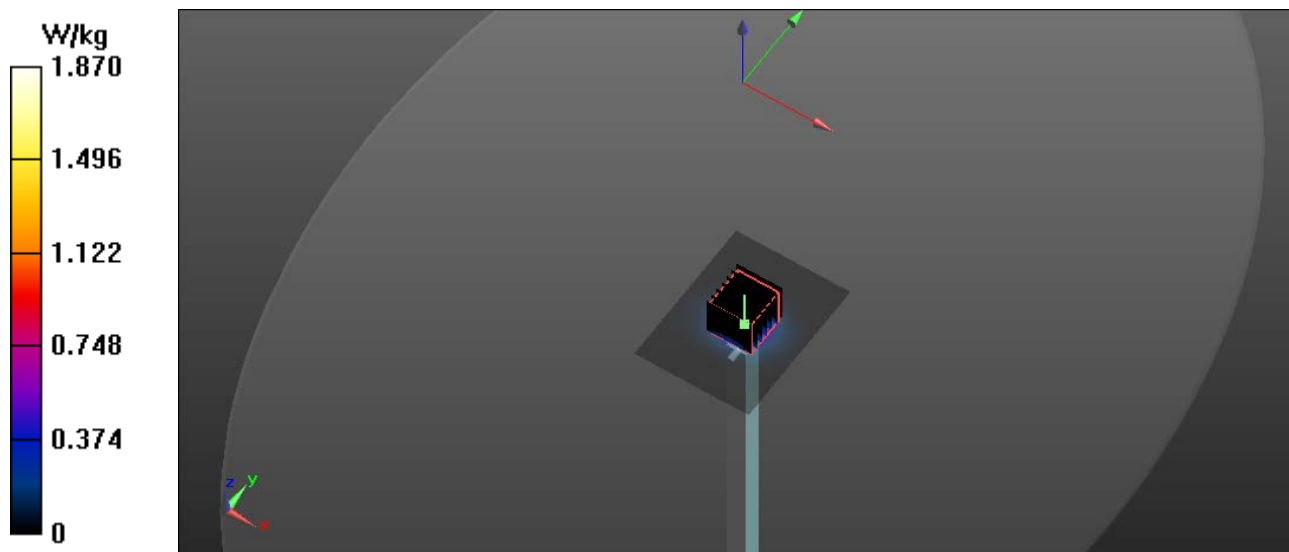

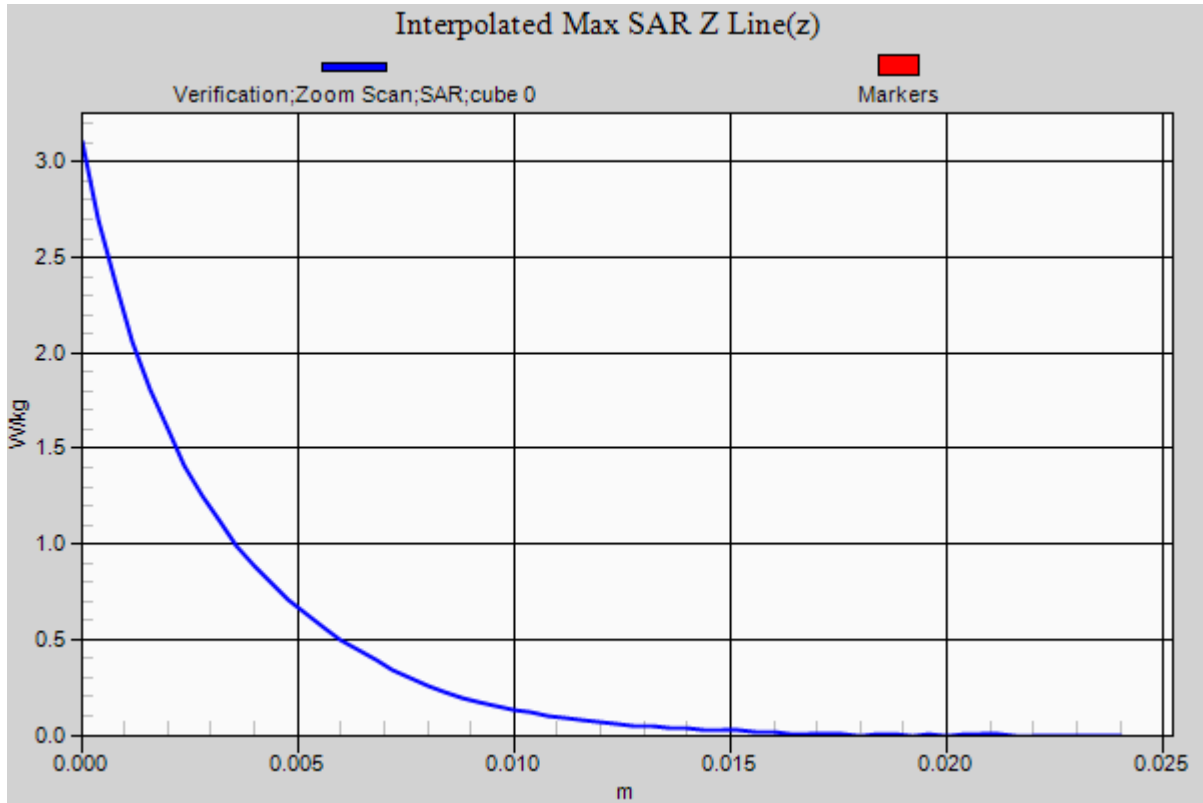

Appendix B – SAR Test Data Plots

RF Exposure Lab

Plot 1

DUT: M1000; Type: Hotspot; Serial: Eng 1

Communication System: LTE (SC-FDMA, 1 RB, 10 MHz, QPSK); Frequency: 782 MHz; Duty Cycle: 1:1
 Medium: MSL750; Medium parameters used (interpolated): $f = 782 \text{ MHz}$; $\sigma = 1.052 \text{ S/m}$; $\epsilon_r = 54.3$; $\rho = 1000 \text{ kg/m}^3$
 Phantom section: Flat Section

Test Date: Date: 2/20/2019; Ambient Temp: 23 °C; Tissue Temp: 21 °C

Probe: EX3DV4 - SN3662; ConvF(9.8, 9.8, 9.8); Calibrated: 4/20/2018;
 Sensor-Surface: 2mm (Mechanical Surface Detection)
 Electronics: DAE4 Sn1321; Calibrated: 1/10/2018
 Phantom: ELI v5.0; Type: QDOVA002AA; Serial: 2037
 Measurement SW: DASY52, Version 52.10 (0); SEMCAD X Version 14.6.10 (7417)

Procedure Notes:

Band 13 LTE/Side A 1 RB 24 Offset Ant 0 Mid/Area Scan (9x13x1): Measurement grid: dx=15mm, dy=15mm

[Info: Interpolated medium parameters used for SAR evaluation.](#)

Maximum value of SAR (measured) = 0.998 W/kg

Band 13 LTE/Side A 1 RB 24 Offset Ant 0 Mid/Zoom Scan (5x5x7)/Cube 0: Measurement grid: dx=8mm, dy=8mm, dz=5mm

Reference Value = 29.27 V/m; Power Drift = 0.02 dB

Peak SAR (extrapolated) = 1.16 W/kg

SAR(1 g) = 0.890 W/kg

[Info: Interpolated medium parameters used for SAR evaluation.](#)

Maximum value of SAR (measured) = 1.04 W/kg

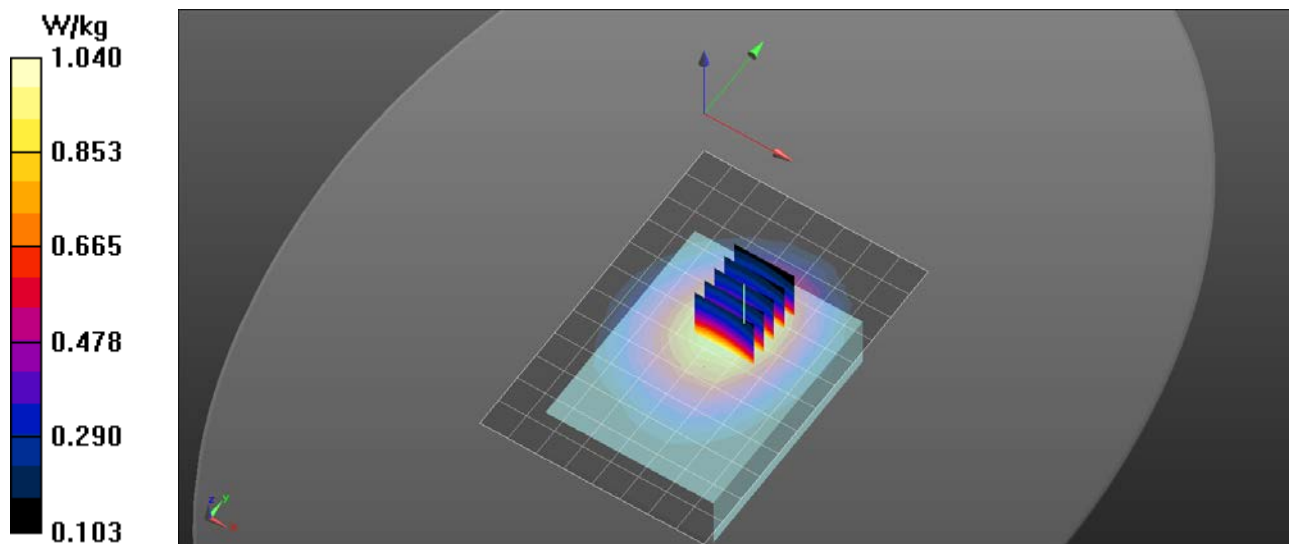

RF Exposure Lab

Plot 2

DUT: M1000; Type: Hotspot; Serial: Eng 1

Communication System: UMTS (WCDMA); Frequency: 836.6 MHz; Duty Cycle: 1:1
 Medium: MSL835; Medium parameters used (interpolated): $f = 836.6$ MHz; $\sigma = 0.982$ S/m; $\epsilon_r = 54.375$; $\rho = 1000$ kg/m³
 Phantom section: Flat Section

Test Date: Date: 3/5/2019; Ambient Temp: 23 °C; Tissue Temp: 21 °C

Probe: EX3DV4 - SN3662; ConvF(9.21, 9.21, 9.21); Calibrated: 4/20/2018;
 Sensor-Surface: 2mm (Mechanical Surface Detection)
 Electronics: DAE4 Sn1321; Calibrated: 1/10/2018
 Phantom: ELI v5.0; Type: QDOVA002AA; Serial: 2037
 Measurement SW: DASY52, Version 52.10 (0); SEMCAD X Version 14.6.10 (7417)

Procedure Notes:

Band 5 UMTS/Side A Ant 0 Mid/Area Scan (9x13x1): Measurement grid: dx=15mm, dy=15mm

[Info: Interpolated medium parameters used for SAR evaluation.](#)

Maximum value of SAR (measured) = 0.936 W/kg

Band 5 UMTS/Side A Ant 0 Mid/Zoom Scan (5x5x7)/Cube 0: Measurement grid: dx=8mm, dy=8mm, dz=5mm

Reference Value = 28.70 V/m; Power Drift = 0.03 dB

Peak SAR (extrapolated) = 1.04 W/kg

SAR(1 g) = 0.817 W/kg

[Info: Interpolated medium parameters used for SAR evaluation.](#)

Maximum value of SAR (measured) = 0.944 W/kg

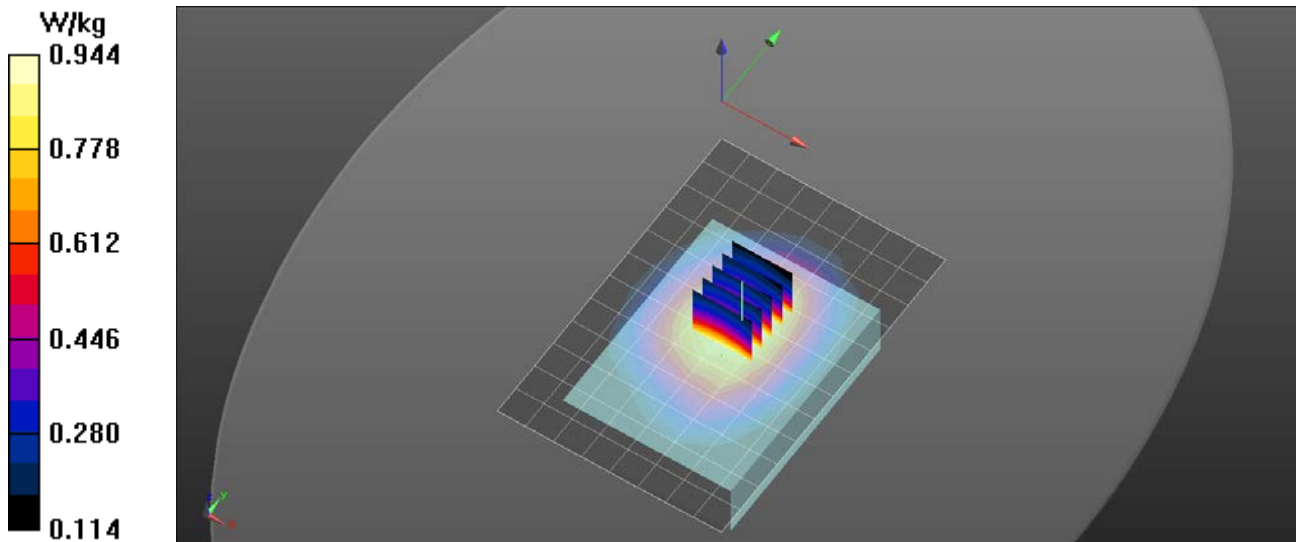

RF Exposure Lab

Plot 3

DUT: M1000; Type: Hotspot; Serial: Eng 1

Communication System: LTE (SC-FDMA, 1 RB, 10 MHz, QPSK); Frequency: 836.5 MHz; Duty Cycle: 1:1
 Medium: MSL835; Medium parameters used (interpolated): $f = 836.5$ MHz; $\sigma = 0.992$ S/m; $\epsilon_r = 54.564$; $\rho = 1000$ kg/m³
 Phantom section: Flat Section

Test Date: Date: 2/18/2019; Ambient Temp: 23 °C; Tissue Temp: 21 °C

Probe: EX3DV4 - SN3662; ConvF(9.21, 9.21, 9.21); Calibrated: 4/20/2018;
 Sensor-Surface: 2mm (Mechanical Surface Detection)
 Electronics: DAE4 Sn1321; Calibrated: 1/10/2018
 Phantom: ELI v5.0; Type: QDOVA002AA; Serial: 2037
 Measurement SW: DASY52, Version 52.10 (0); SEMCAD X Version 14.6.10 (7417)

Procedure Notes:

Band 5 LTE/Side A 1 RB 24 Offset Ant 0 Mid/Area Scan (9x13x1): Measurement grid: dx=15mm, dy=15mm

[Info: Interpolated medium parameters used for SAR evaluation.](#)

Maximum value of SAR (measured) = 0.705 W/kg

Band 5 LTE/Side A 1 RB 24 Offset Ant 0 Mid/Zoom Scan (5x5x7)/Cube 0: Measurement grid: dx=8mm, dy=8mm, dz=5mm

Reference Value = 24.81 V/m; Power Drift = -0.02 dB

Peak SAR (extrapolated) = 0.816 W/kg

SAR(1 g) = 0.623 W/kg

[Info: Interpolated medium parameters used for SAR evaluation.](#)

Maximum value of SAR (measured) = 0.727 W/kg

Band 5 LTE/Side A 1 RB 24 Offset Ant 0 Mid/Zoom Scan (5x5x7)/Cube 1: Measurement grid: dx=8mm, dy=8mm, dz=5mm

Reference Value = 24.81 V/m; Power Drift = -0.02 dB

Peak SAR (extrapolated) = 0.745 W/kg

SAR(1 g) = 0.573 W/kg

[Info: Interpolated medium parameters used for SAR evaluation.](#)

Maximum value of SAR (measured) = 0.673 W/kg

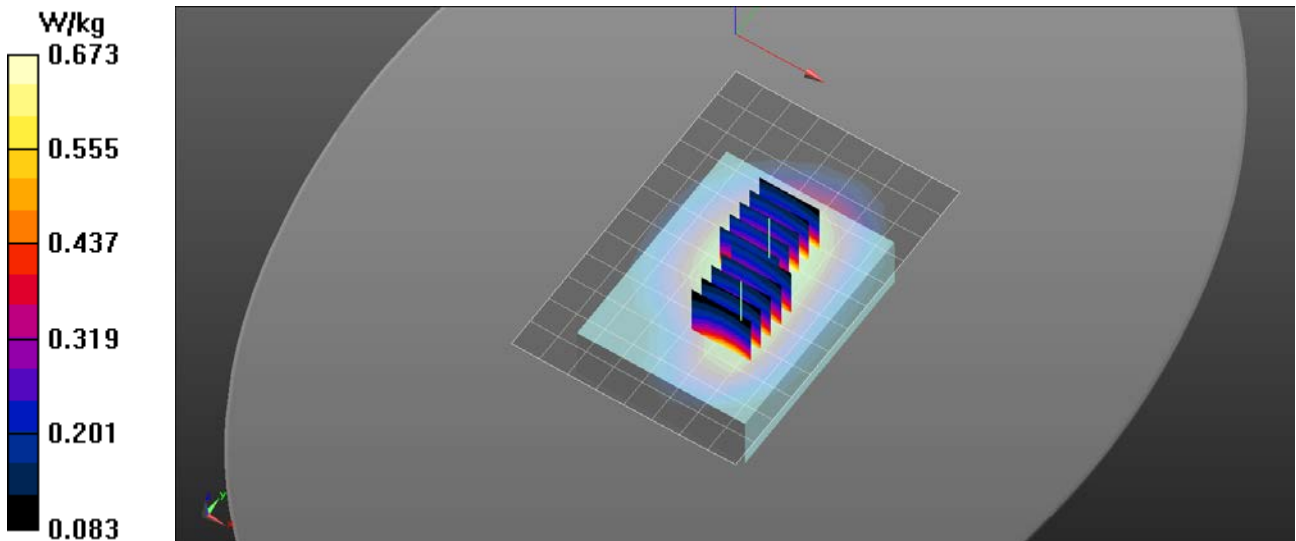

RF Exposure Lab

Plot 4

DUT: M1000; Type: Hotspot; Serial: Eng 1

Communication System: UMTS (WCDMA); Frequency: 1752.6 MHz; Duty Cycle: 1:1
 Medium: MSL1750; Medium parameters used (interpolated): $f = 1752.6$ MHz; $\sigma = 1.56$ S/m; $\epsilon_r = 52.675$; $\rho = 1000$ kg/m³
 Phantom section: Flat Section

Test Date: Date: 3/6/2019; Ambient Temp: 23 °C; Tissue Temp: 21 °C

Probe: EX3DV4 - SN3662; ConvF(7.96, 7.96, 7.96); Calibrated: 4/20/2018;
 Sensor-Surface: 2mm (Mechanical Surface Detection)
 Electronics: DAE4 Sn1321; Calibrated: 1/10/2018
 Phantom: ELI v5.0; Type: QDOVA002AA; Serial: 2037
 Measurement SW: DASY52, Version 52.10 (0); SEMCAD X Version 14.6.10 (7417)

Procedure Notes:

Band 4 UMTS/Side A Ant 0 High/Area Scan (9x13x1): Measurement grid: dx=15mm, dy=15mm

[Info: Interpolated medium parameters used for SAR evaluation.](#)

Maximum value of SAR (measured) = 1.21 W/kg

Band 4 UMTS/Side A Ant 0 High/Zoom Scan (5x5x7)/Cube 0: Measurement grid: dx=8mm, dy=8mm, dz=5mm

Reference Value = 17.06 V/m; Power Drift = 0.04 dB

Peak SAR (extrapolated) = 1.48 W/kg

SAR(1 g) = 1.17 W/kg

[Info: Interpolated medium parameters used for SAR evaluation.](#)

Maximum value of SAR (measured) = 1.22 W/kg

Band 4 UMTS/Side A Ant 0 High/Zoom Scan (5x5x7)/Cube 1: Measurement grid: dx=8mm, dy=8mm, dz=5mm

Reference Value = 17.06 V/m; Power Drift = 0.04 dB

Peak SAR (extrapolated) = 1.16 W/kg

SAR(1 g) = 1.02 W/kg

[Info: Interpolated medium parameters used for SAR evaluation.](#)

Maximum value of SAR (measured) = 0.969 W/kg

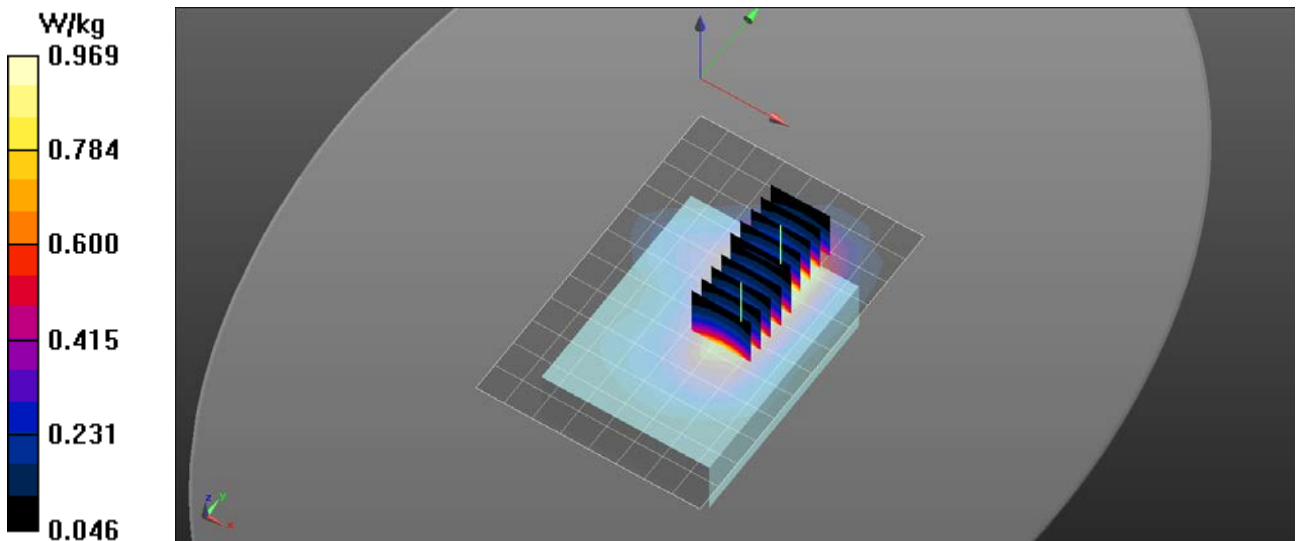

RF Exposure Lab

Plot 5

DUT: M1000; Type: Hotspot; Serial: Eng 1

Communication System: LTE (SC-FDMA, 1 RB, 20 MHz, QPSK); Frequency: 1770 MHz; Duty Cycle: 1:1
Medium: MSL1750; Medium parameters used: $f = 1770$ MHz; $\sigma = 1.55$ S/m; $\epsilon_r = 52.63$; $\rho = 1000$ kg/m³
Phantom section: Flat Section

Test Date: Date: 2/21/2019; Ambient Temp: 23 °C; Tissue Temp: 21 °C

Probe: EX3DV4 - SN3662; ConvF(7.96, 7.96, 7.96); Calibrated: 4/20/2018;
Sensor-Surface: 2mm (Mechanical Surface Detection)
Electronics: DAE4 Sn1321; Calibrated: 1/10/2018
Phantom: ELI v5.0; Type: QDOVA002AA; Serial: 2037
Measurement SW: DASY52, Version 52.10 (0); SEMCAD X Version 14.6.10 (7417)

Procedure Notes:

Band 66 LTE/Side A 1 RB 49 Offset Ant 0 High/Area Scan (9x13x1): Measurement grid: dx=15mm, dy=15mm
Maximum value of SAR (measured) = 1.06 W/kg

Band 66 LTE/Side A 1 RB 49 Offset Ant 0 High/Zoom Scan (5x5x7)/Cube 0: Measurement grid: dx=8mm, dy=8mm, dz=5mm
Reference Value = 11.93 V/m; Power Drift = -0.03 dB
Peak SAR (extrapolated) = 1.40 W/kg
SAR(1 g) = 0.861 W/kg
Maximum value of SAR (measured) = 1.13 W/kg

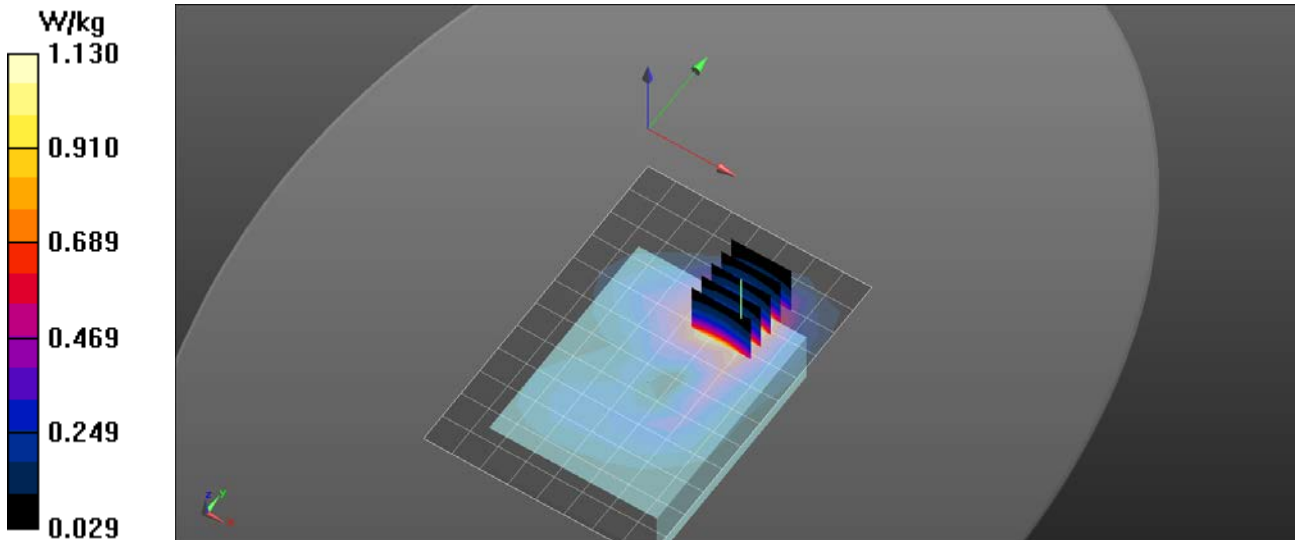

RF Exposure Lab

Plot 6

DUT: M1000; Type: Hotspot; Serial: Eng 1

Communication System: UMTS (WCDMA); Frequency: 1907.6 MHz; Duty Cycle: 1:1
Medium: MSL1900; Medium parameters used (interpolated): $f = 1907.6$ MHz; $\sigma = 1.548$ S/m; $\epsilon_r = 53.155$; $\rho = 1000$ kg/m³
Phantom section: Flat Section

Test Date: Date: 3/4/2019; Ambient Temp: 23 °C; Tissue Temp: 21 °C

Probe: EX3DV4 - SN3662; ConvF(7.61, 7.61, 7.61); Calibrated: 4/20/2018;
Sensor-Surface: 2mm (Mechanical Surface Detection)
Electronics: DAE4 Sn1321; Calibrated: 1/10/2018
Phantom: ELI v5.0; Type: QDOVA002AA; Serial: 2037
Measurement SW: DASY52, Version 52.10 (0); SEMCAD X Version 14.6.10 (7417)

Procedure Notes:

Band 2 UMTS/Side A Ant 0 High/Area Scan (9x13x1): Measurement grid: dx=15mm, dy=15mm

[Info: Interpolated medium parameters used for SAR evaluation.](#)

Maximum value of SAR (measured) = 1.32 W/kg

Band 2 UMTS/Side A Ant 0 High/Zoom Scan (5x5x7)/Cube 0: Measurement grid: dx=8mm, dy=8mm, dz=5mm

Reference Value = 12.58 V/m; Power Drift = -0.00 dB

Peak SAR (extrapolated) = 1.68 W/kg

SAR(1 g) = 1.03 W/kg

[Info: Interpolated medium parameters used for SAR evaluation.](#)

Maximum value of SAR (measured) = 1.37 W/kg

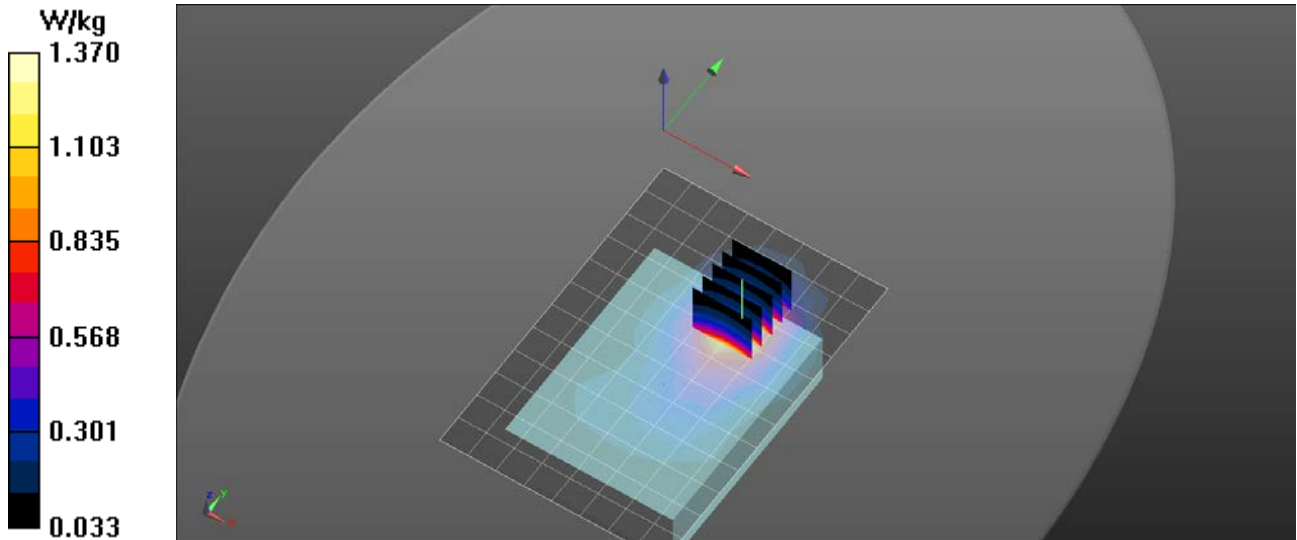

RF Exposure Lab

Plot 7

DUT: M1000; Type: Hotspot; Serial: Eng 1

Communication System: LTE (SC-FDMA, 1 RB, 20 MHz, QPSK); Frequency: 1900 MHz; Duty Cycle: 1:1
 Medium: MSL1900; Medium parameters used: $f = 1900$ MHz; $\sigma = 1.58$ S/m; $\epsilon_r = 52.97$; $\rho = 1000$ kg/m³
 Phantom section: Flat Section

Test Date: Date: 2/11/2019; Ambient Temp: 23 °C; Tissue Temp: 21 °C

Probe: EX3DV4 - SN3662; ConvF(7.61, 7.61, 7.61); Calibrated: 4/20/2018;
 Sensor-Surface: 2mm (Mechanical Surface Detection)
 Electronics: DAE4 Sn1321; Calibrated: 1/10/2018
 Phantom: ELI v5.0; Type: QDOVA002AA; Serial: 2037
 Measurement SW: DASY52, Version 52.10 (0); SEMCAD X Version 14.6.10 (7417)

Procedure Notes:

Band 2 LTE/Side A 1 RB 49 Offset Ant 0 High/Area Scan (9x13x1): Measurement grid: dx=15mm, dy=15mm
 Maximum value of SAR (measured) = 1.31 W/kg

Band 2 LTE/Side A 1 RB 49 Offset Ant 0 High/Zoom Scan (5x5x7)/Cube 0: Measurement grid: dx=8mm, dy=8mm, dz=5mm
 Reference Value = 12.31 V/m; Power Drift = -0.02 dB
 Peak SAR (extrapolated) = 1.63 W/kg
SAR(1 g) = 0.964 W/kg

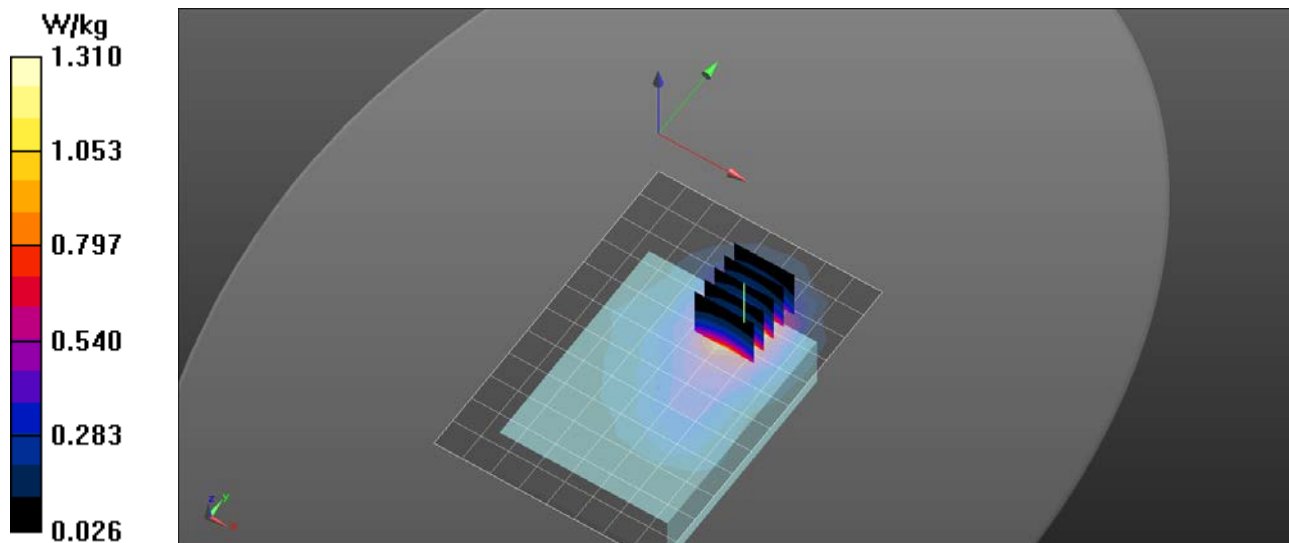

RF Exposure Lab

Plot 8

DUT: M1000; Type: Hotspot; Serial: Eng 1

Communication System: LTE-TDD (SC-FDMA, 1 RB, 20 MHz, QPSK); Frequency: 3592.5 MHz; Duty Cycle: 1:1
 Medium: MSL 3-6 GHz; Medium parameters used (interpolated): $f = 3592.5$ MHz; $\sigma = 3.433$ S/m; $\epsilon_r = 50.978$; $\rho = 1000$ kg/m³
 Phantom section: Flat Section

Test Date: Date: 4/9/2019; Ambient Temp: 23 °C; Tissue Temp: 21 °C

Probe: EX3DV4 - SN3662; ConvF(7, 7, 7); Calibrated: 4/20/2018;
 Sensor-Surface: 2mm (Mechanical Surface Detection)
 Electronics: DAE4 Sn1321; Calibrated: 1/10/2019
 Phantom: ELI v5.0; Type: QDOVA002AA; Serial: 2037
 Measurement SW: DASY52, Version 52.10 (0); SEMCAD X Version 14.6.10 (7417)

Procedure Notes:

Band 48 LTE/Side A 1 RB 49 Offset Ant 4 Mid1/Area Scan (13x19x1): Measurement grid: dx=10mm, dy=10mm

[Info: Interpolated medium parameters used for SAR evaluation.](#)

Maximum value of SAR (measured) = 0.929 W/kg

Band 48 LTE/Side A 1 RB 49 Offset Ant 4 Mid1/Zoom Scan (7x7x12)/Cube 0: Measurement grid: dx=5mm, dy=5mm, dz=2mm

Reference Value = 7.247 V/m; Power Drift = -0.01 dB

Peak SAR (extrapolated) = 1.48 W/kg

SAR(1 g) = 0.577 W/kg

[Info: Interpolated medium parameters used for SAR evaluation.](#)

Maximum value of SAR (measured) = 0.943 W/kg

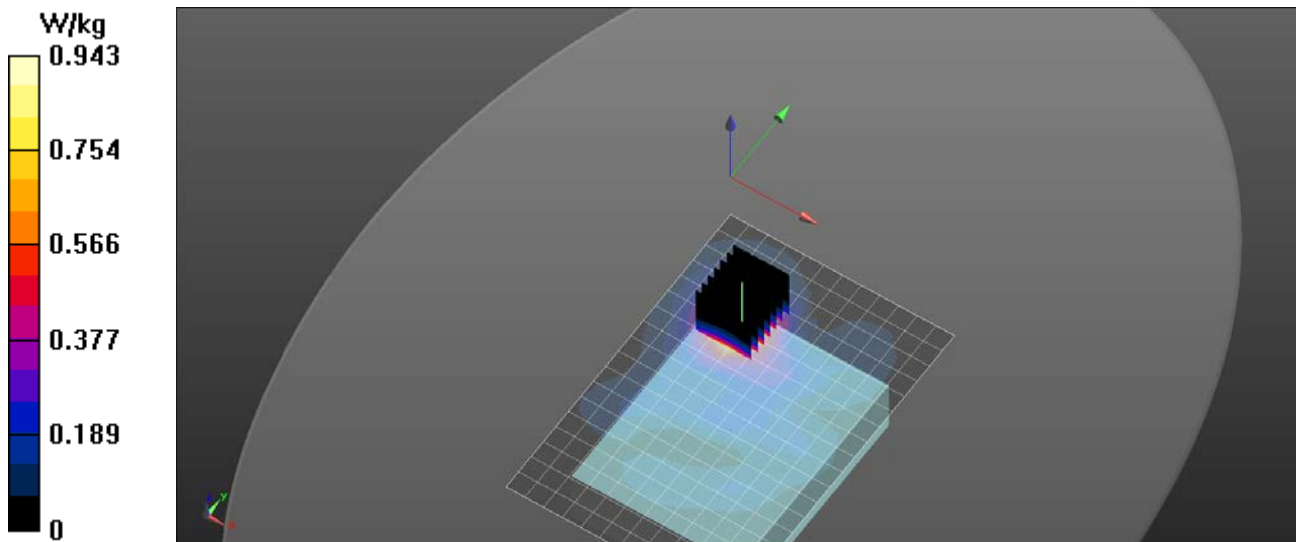

RF Exposure Lab

Plot 9

DUT: M1000; Type: Hotspot; Serial: Eng 1

Communication System: WiFi 802.11b (DSSS, 11 Mbps); Frequency: 2437 MHz; Duty Cycle: 1:1
Medium: MSL2450; Medium parameters used (interpolated): $f = 2437$ MHz; $\sigma = 1.984$ S/m; $\epsilon_r = 52.606$; $\rho = 1000$ kg/m³
Phantom section: Flat Section

Test Date: Date: 3/13/2019; Ambient Temp: 23 °C; Tissue Temp: 21 °C

Probe: EX3DV4 - SN3662; ConvF(7.29, 7.29, 7.29); Calibrated: 4/20/2018;
Sensor-Surface: 2mm (Mechanical Surface Detection)
Electronics: DAE4 Sn1321; Calibrated: 1/10/2018
Phantom: ELI v5.0; Type: QDOVA002AA; Serial: 2037
Measurement SW: DASY52, Version 52.10 (0); SEMCAD X Version 14.6.10 (7417)

Procedure Notes:

2450 MHz/Side D Ant 1 Mid/Area Scan (10x19x1): Measurement grid: dx=10mm, dy=10mm

Info: [Interpolated medium parameters used for SAR evaluation.](#)

Maximum value of SAR (measured) = 0.144 W/kg

2450 MHz/Side D Ant 1 Mid/Zoom Scan (7x7x7)/Cube 0: Measurement grid: dx=5mm, dy=5mm, dz=5mm

Reference Value = 5.019 V/m; Power Drift = 0.04 dB

Peak SAR (extrapolated) = 0.190 W/kg

SAR(1 g) = 0.099 W/kg

Info: [Interpolated medium parameters used for SAR evaluation.](#)

