



FCC/ISED CO-LOCATION RADIO TEST REPORT

FCC ID : PKRISGM1000
IC : 3229A-M1000
Equipment : M1000
Brand Name : inseego
Model Name : M1000
Marketing Name : 5G MiFi M1000
HVIN : M1000
PMN : 5G MiFi M1000
Applicant : Inseego Corp.
9605 Scranton Road, Suite 300, San Diego, CA 92121
Manufacturer : Inseego Corp.
9605 Scranton Road, Suite 300, San Diego, CA 92121
Standard : 47 CFR Part 2, 22(H), 24(E), 27
ISED RSS-132 Issue 3
ISED RSS-133 Issue 6
ISED RSS-130 Issue 2
ISED RSS-139 Issue 3

The product was received on May 03, 2019 and testing was started from May 09, 2019 and completed on May 10, 2019. We, SPORTON INTERNATIONAL INC. EMC & Wireless Communications Laboratory, would like to declare that the tested sample has been evaluated in accordance with the test procedures given in ANSI / TIA-603-E and has been in compliance with the applicable technical standards.

The report must not be used by the client to claim product certification, approval, or endorsement by TAF or any agency of government.

The test results in this partial report apply exclusively to the tested model / sample. Without written approval of SPORTON INTERNATIONAL INC. EMC & Wireless Communications Laboratory, the test report shall not be reproduced except in full.



Jones Tsai

Approved by: Jones Tsai

SPORTON INTERNATIONAL INC. EMC & Wireless Communications Laboratory
No. 52, Huaya 1st Rd., Guishan Dist., Taoyuan City, Taiwan (R.O.C.)



Table of Contents

History of this test report.....	4
Summary of Test Result.....	5
1 General Description	6
1.1 Product Feature of Equipment Under Test.....	6
1.2 Modification of EUT	6
1.3 Testing Location	6
1.4 Applicable Standards.....	7
2 Test Configuration of Equipment Under Test	8
2.1 Test Mode.....	8
2.2 Connection Diagram of Test System.....	8
2.3 Support Unit used in test configuration and system	9
2.4 Frequency List of Low/Middle/High Channels	9
3 Radiated Test Items	11
3.1 Measuring Instruments	11
3.2 Radiated Spurious Emission Measurement	12
4 List of Measuring Equipment.....	14
5 Uncertainty of Evaluation	16
Appendix A. Test Results of Radiated Test	
Appendix B. Test Setup Photographs	



History of this test report

Report No.	Version	Description	Issued Date
FG950301B	01	Initial issue of report	May 11, 2019



Summary of Test Result

Report Clause	FCC Ref Std. Clause	ISED Ref Std. Clause	Test Items	Result (PASS/FAIL)	Remark
3.2	§2.1053 §22.917 (a) §24.238 (a) §27.53 (c)(2) §27.53 (f) §27.53 (h)	RSS-132 5.5 RSS-133 6.5.1 RSS-130 4.7 RSS-139 6.6	Radiated Spurious Emission (Band 2) (Band 4) (Band 5) (Band 13)	Pass	Under limit 18.64 dB at 5640.000 MHz

Note: This is report for colocation test.

Declaration of Conformity:
The test results with all measurement uncertainty excluded are presented in accordance with the regulation limits or requirements declared by manufacturers.
Comments and Explanations:
The declared of product specification for EUT presented in the report are provided by the manufacturer, and the manufacturer takes all the responsibilities for the accuracy of product specification.

Reviewed by: Wii Chang

Report Producer: Natasha Hsieh



1 General Description

1.1 Product Feature of Equipment Under Test

The EUT supports UMTS/LTE/NR/WiFi. The details please find the Operating Description.

1.2 Modification of EUT

No modifications are made to the EUT during all test items.

1.3 Testing Location

Test Site	SPORTON INTERNATIONAL INC.	
Test Site Location	No.52, Huaya 1st Rd., Guishan Dist., Taoyuan City, Taiwan (R.O.C.) TEL: +886-3-327-3456 FAX: +886-3-328-4978	
Test Site No.	Sporton Site No.	ISED Registration No.
	03CH07-HY	4086B
Test Engineer	Jesse Wang, Stan Hsieh, and Nick Yu	
Temperature	22~24°C	
Relative Humidity	53~55%	

Note: The test site complies with ANSI C63.4 2014 requirement.

Test Site	SPORTON INTERNATIONAL INC.	
Test Site Location	No.58, Aly. 75, Ln. 564, Wenhua 3rd, Rd., Guishan Dist., Taoyuan City, Taiwan (R.O.C.) TEL: +886-3-327-0868 FAX: +886-3-327-0855	
Test Site No.	Sporton Site No.	ISED Registration No.
	03CH15-HY	4086B
Test Engineer	Watt Tseng	
Temperature	23~24°C	
Relative Humidity	55~56%	

Note: The test site complies with ANSI C63.4 2014 requirement.

FCC Designation No. TW1190 and TW0007



1.4 Applicable Standards

According to the specifications of the manufacturer, the EUT must comply with the requirements of the following standards:

- ♦ ANSI C63.26-2015
- ♦ ANSI / TIA-603-E
- ♦ 47 CFR Part 2, 22(H), 24(E), 27
- ♦ FCC KDB 971168 D01 Power Meas. License Digital Systems v03r01
- ♦ ISED RSS-132 Issue 3
- ♦ ISED RSS-133 Issue 6
- ♦ ISED RSS-130 Issue 2
- ♦ ISED RSS-139 Issue 3

Remark: All test items were verified and recorded according to the standards and without any deviation during the test.

2 Test Configuration of Equipment Under Test

2.1 Test Mode

Antenna port conducted and radiated test items listed below are performed according to KDB 971168 D01 Power Meas. License Digital Systems v03r01 with maximum output power.

For radiated measurement, pre-scanned in three orthogonal panels, X, Y, Z. The worst cases (LF: X Plane for Co-Location Band 4 + Band 5, Z Plane for Co-Location Band 2 + Band 5, Band 2 + Band 13 and Band 4 + Band 13 ; HF: Y Plane for Co-Location Band 2 + Band 5 and Band 4 + Band 5, and X Plane for Co-Location Band 2 + Band 13 and Band 4 + Band 13) were recorded in this report.

<Co-Location>

Test Mode	
Mode 1:	Band 2 (20M 1RB49 QPSK) + Band 5 (10M 1RB24 QPSK)
Mode 2:	Band 4 (20M 1RB49 QPSK) + Band 5 (10M 1RB24 QPSK)
Mode 3:	Band 2 (20M 1RB49 QPSK) + Band 13 (10M 1RB24 QPSK)
Mode 4:	Band 4 (20M 1RB49 QPSK) + Band 13 (10M 1RB24 QPSK)

2.2 Connection Diagram of Test System

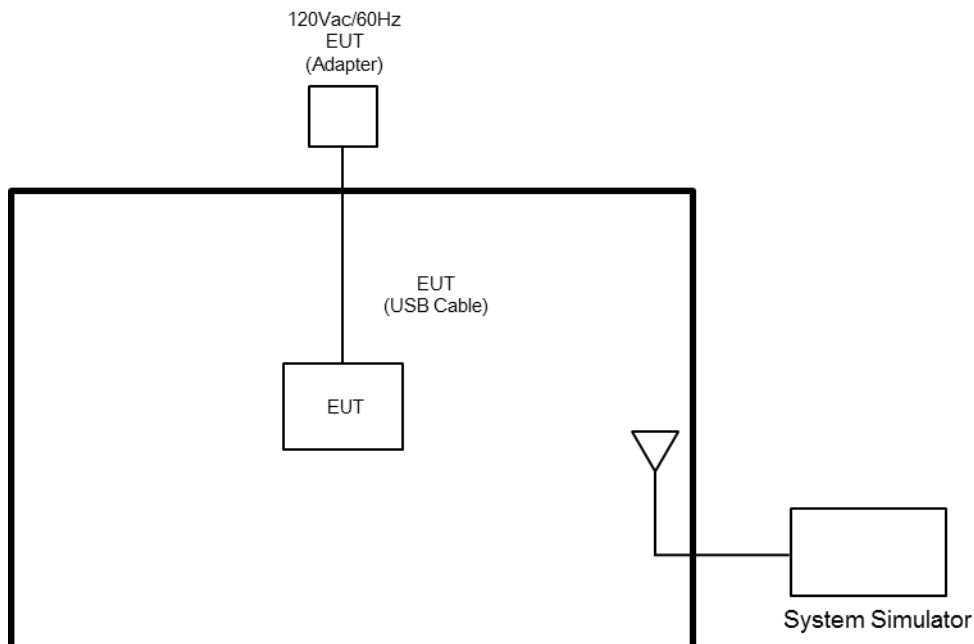



2.3 Support Unit used in test configuration and system

Item	Equipment	Trade Name	Model No.	FCC ID	Data Cable	Power Cord
1.	LTE Base Station	Anritsu	8821C	N/A	N/A	Unshielded, 1.8 m

2.4 Frequency List of Low/Middle/High Channels

LTE Band 2 Channel and Frequency List				
BW [MHz]	Channel/Frequency(MHz)	Lowest	Middle	Highest
20	Channel	18700	18900	19100
	Frequency	1860	1880	1900
15	Channel	18675	18900	19125
	Frequency	1857.5	1880	1902.5
10	Channel	18650	18900	19150
	Frequency	1855	1880	1905
5	Channel	18625	18900	19175
	Frequency	1852.5	1880	1907.5
3	Channel	18615	18900	19185
	Frequency	1851.5	1880	1908.5
1.4	Channel	18607	18900	19193
	Frequency	1850.7	1880	1909.3

LTE Band 4 Channel and Frequency List				
BW [MHz]	Channel/Frequency(MHz)	Lowest	Middle	Highest
20	Channel	20050	20175	20300
	Frequency	1720	1732.5	1745
15	Channel	20025	20175	20325
	Frequency	1717.5	1732.5	1747.5
10	Channel	20000	20175	20350
	Frequency	1715	1732.5	1750
5	Channel	19975	20175	20375
	Frequency	1712.5	1732.5	1752.5
3	Channel	19965	20175	20385
	Frequency	1711.5	1732.5	1753.5
1.4	Channel	19957	20175	20393
	Frequency	1710.7	1732.5	1754.3



LTE Band 5 Channel and Frequency List				
BW [MHz]	Channel/Frequency(MHz)	Lowest	Middle	Highest
10	Channel	20450	20525	20600
	Frequency	829	836.5	844
5	Channel	20425	20525	20625
	Frequency	826.5	836.5	846.5
3	Channel	20415	20525	20635
	Frequency	825.5	836.5	847.5
1.4	Channel	20407	20525	20643
	Frequency	824.7	836.5	848.3

LTE Band 13 Channel and Frequency List				
BW [MHz]	Channel/Frequency(MHz)	Lowest	Middle	Highest
10	Channel	-	23230	-
	Frequency	-	782	-
5	Channel	23205	23230	23255
	Frequency	779.5	782	784.5

3 Radiated Test Items

3.1 Measuring Instruments

See list of measuring instruments of this test report.

3.1.1 Test Setup

For radiated test from 30MHz to 1GHz

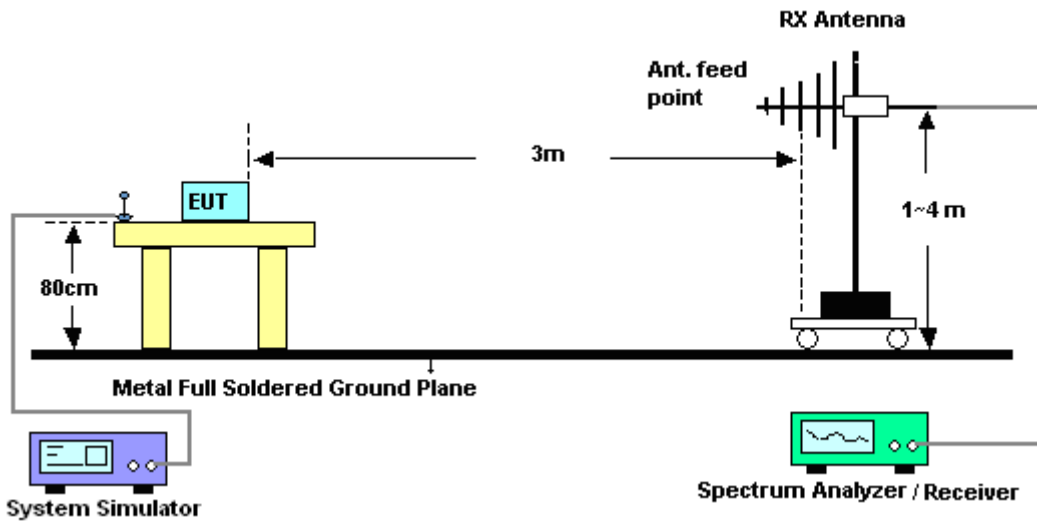

For radiated test above 1GHz

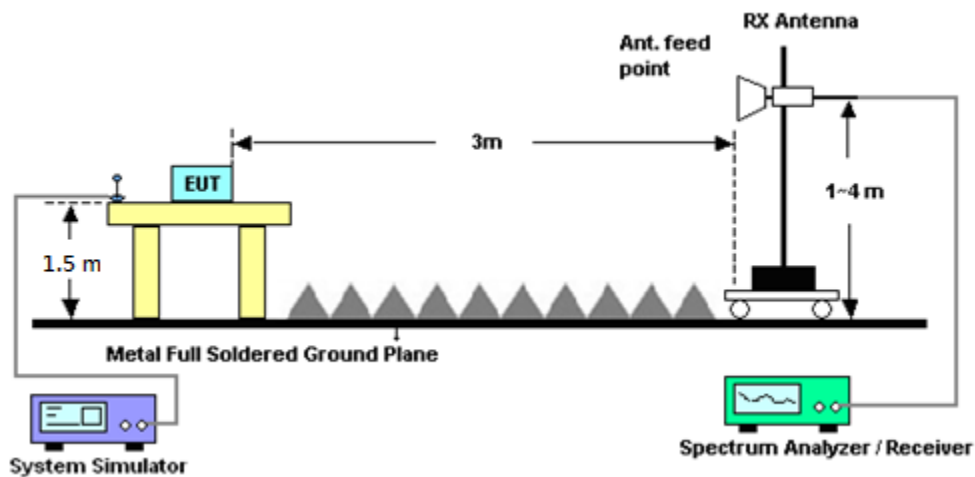

3.1.2 Test Result of Radiated Test

Please refer to Appendix A.

3.2 Radiated Spurious Emission Measurement

3.2.1 Description of Radiated Spurious Emission Measurement

22.917(a) / RSS-132

For operations in the 824 – 849 MHz band, the FCC limit is $43 + 10\log_{10}(P[\text{Watts}])$ dB below the transmitter power $P(\text{Watts})$ in a 100kHz bandwidth. However, in the 1MHz bands immediately outside and adjacent to the licensee's frequency block, a resolution bandwidth of at least one percent of the emission bandwidth of the fundamental emission of the transmitter may be employed.

24.238 (a) / RSS-133

For operations in the 1850-1910 and 1930-1990 MHz band, the FCC limit is $43 + 10\log_{10}(P[\text{Watts}])$ dB below the transmitter power $P(\text{Watts})$ in a 1MHz bandwidth. However, in the 1 MHz bands immediately outside and adjacent to the frequency block a resolution bandwidth of at least one percent of the emission bandwidth of the fundamental emission of the transmitter may be employed.

27.53 (c) / RSS-130

For operations in the 776-788 MHz band, the FCC limit is $43 + 10\log_{10}(P[\text{Watts}])$ dB below the transmitter power $P(\text{Watts})$ in a 100 kHz bandwidth. However, in the 100 kHz bands immediately outside and adjacent to the frequency block, a resolution bandwidth of at least 30 kHz may be employed. In addition, the power of any unwanted emissions in any 6.25 kHz bandwidth for all frequencies between 763-775 MHz and 793-806 MHz shall be attenuated below the transmitter power, P (dBW), by at least $65 + 10 \log_{10} p(\text{watts})$, dB, for mobile and portable equipment.

27.53 (h) / RSS-139

For operations in the 1710 – 1755 MHz band, the FCC limit is $43 + 10\log_{10}(P[\text{Watts}])$ dB below the transmitter power $P(\text{Watts})$ in a 1 MHz bandwidth. However, in the 1MHz bands immediately outside and adjacent to the licensee's frequency block, a resolution bandwidth of at least one percent of the emission bandwidth of the fundamental emission of the transmitter may be employed.

The radiated spurious emission was measured by substitution method according to ANSI / TIA-603-E. The power of any emission outside of the authorized operating frequency ranges must be attenuated below the transmitter power (P) by a factor of at least $43 + 10 \log (P)$ dB.



For LTE Band 13

For operations in the 746-758 MHz, 775-788 MHz, and 805-806 MHz bands, emissions in the band 1559-1610 MHz shall be limited to -70 dBW/MHz equivalent isotropically radiated power (EIRP) for wideband signals, and -80 dBW EIRP for discrete emissions of less than 700 Hz bandwidth.

The spectrum is scanned from 30 MHz up to a frequency including its 10th harmonic.

3.2.2 Test Procedures

The testing follows FCC KDB 971168 D01 v03r01 Section 5.8, ANSI C63.26 Section 5.5.3 and ANSI / TIA-603-E Section 2.2.12.

1. The EUT was placed on a turntable with 0.8 meter for frequency below 1GHz and 1.5 meter for frequency above 1GHz respectively above ground.
2. The EUT was set 3 meters from the receiving antenna, which was mounted on the antenna tower.
3. The table was rotated 360 degrees to determine the position of the highest spurious emission.
4. The height of the receiving antenna is varied between one meter and four meters to search the maximum spurious emission for both horizontal and vertical polarizations.
5. Make the measurement with the spectrum analyzer's RBW = 1MHz, VBW = 3MHz, taking the record of maximum spurious emission.
6. A horn antenna was substituted in place of the EUT and was driven by a signal generator.
7. Tune the output power of signal generator to the same emission level with EUT maximum spurious emission.
8. Taking the record of output power at antenna port.
9. Repeat step 7 to step 8 for another polarization.
10. The RF fundamental frequency should be excluded against the limit line in the operating frequency band.

The limit line is derived from $43 + 10\log(P)$ dB below the transmitter power P(Watts)



4 List of Measuring Equipment

Instrument	Manufacturer	Model No.	Serial No.	Characteristics	Calibration Date	Test Date	Due Date	Remark
Double Ridge Horn Antenna	ESCO	3117	00075962	1GHz ~ 18GHz	Dec. 02, 2018	May 09, 2019~ May 10, 2019	Dec. 03, 2019	Radiation (03CH07-HY)
EMI Test Receiver	Agilent	N9038A(MXE)	MY53290053	20Hz to 26.5GHz	Jan. 23, 2019	May 09, 2019~ May 10, 2019	Jan. 22, 2020	Radiation (03CH07-HY)
Preamplifier	Agilent	8449B	3008A02362	1GHz~ 26.5GHz	Nov. 02, 2018	May 09, 2019~ May 10, 2019	Nov. 01, 2019	Radiation (03CH07-HY)
Notch Filter	Wainwright	WRCT698/798-10/40 8SSK	SN1	AWS Band	Nov. 07, 2018	May 09, 2019~ May 10, 2019	Nov. 06, 2019	Radiation (03CH07-HY)
Filter	Microwave	H1G013G1	SN477215	1.0G High Pass	Nov. 02, 2018	May 09, 2019~ May 10, 2019	Nov. 01, 2019	Radiation (03CH07-HY)
RF Cable	HUBER + SUHNER	SUCOFLEX 104	MY28655/4, MY24971/4, MY15682/4	1GHz~18GHz	Feb. 26, 2019	May 09, 2019~ May 10, 2019	Feb. 25, 2020	Radiation (03CH07-HY)
Antenna Mast	Max-Full	MFA520BS	N/A	1m~4m	N/A	May 09, 2019~ May 10, 2019	N/A	Radiation (03CH07-HY)
Turn Table	ChainTek	Chaintek 3000	N/A	0~360 Degree	N/A	May 09, 2019~ May 10, 2019	N/A	Radiation (03CH07-HY)
Horn Antenna	ESCO	3117	00143261	1GHz~18GHz	Jan. 07, 2019	May 09, 2019~ May 10, 2019	Jan. 06, 2020	Radiation (03CH07-HY)
Notch Filter	Wainwright	WRCD1700/2000-0.2/40-10S SK	SN37	DCS 1900	Aug. 23, 2018	May 09, 2019~ May 10, 2019	Aug. 22, 2019	Radiation (03CH07-HY)
Filter	Microwave	H3G018G1	SN477220	3.0G High Pass	Aug. 23, 2018	May 09, 2019~ May 10, 2019	Aug. 22, 2019	Radiation (03CH07-HY)
Notch Filter	Wainwright	WRCG1710/1755-1690/1755-45/7SS	SN2	AWS Band	Nov. 06, 2018	May 09, 2019~ May 10, 2019	Nov. 05, 2019	Radiation (03CH07-HY)
Software	Audix	E3 6.2009-8-24	80504004656 H	N/A	N/A	May 09, 2019~ May 10, 2019	N/A	Radiation (03CH07-HY)
Signal Generator	Rohde & Schwarz	SMF100A	101107	100kHz~40GHz	May. 22, 2018	May 09, 2019~ May 10, 2019	May 21, 2019	Radiation (03CH07-HY)
Loop Antenna	Rohde & Schwarz	HFH2-Z2	100488	9 kHz~30 MHz	Jan. 07, 2019	May 10, 2019	Jan. 06, 2020	Radiation (03CH15-HY)
Amplifier	SONOMA	310N	363440	9kHz~1GHz	Dec. 28, 2018	May 10, 2019	Dec. 27, 2019	Radiation (03CH15-HY)
Bilog Antenna	TESEQ	CBL6111D&00800N1D01N-06	41912&05	30MHz to 1GHz	Feb. 12, 2019	May 10, 2019	Feb. 11, 2020	Radiation (03CH15-HY)
Spectrum Analyzer	Agilent	N9010A	MY53470118	10Hz~44GHz	Apr. 18, 2019	May 10, 2019	Apr. 17, 2020	Radiation (03CH15-HY)
Antenna Mast	ChainTek	MBS-520-1	N/A	1m~4m	N/A	May 10, 2019	N/A	Radiation (03CH15-HY)
Turn Table	ChainTek	T-200-S-1	N/A	0~360 Degree	N/A	May 10, 2019	N/A	Radiation (03CH15-HY)
Signal Generator	Rohde & Schwarz	SMF100A	101107	100kHz~40GHz	May 22, 2018	May 10, 2019	May 21, 2019	Radiation (03CH15-HY)
Software	Audix	E3 6.2009-8-24	RK-000451	N/A	N/A	May 10, 2019	N/A	Radiation (03CH15-HY)
Bilog Antenna	TESEQ	CBL 6111D&00800N1D01N-06	40103&07	30MHz to 1GHz	Apr. 30, 2019	May 10, 2019	Apr. 29, 2020	Radiation (03CH15-HY)
Filter	Wainwright	WLK4-1000-1530-8000-40SS	SN11	1G Low Pass	Sep. 16, 2018	May 10, 2019	Sep. 15, 2019	Radiation (03CH15-HY)



Instrument	Manufacturer	Model No.	Serial No.	Characteristics	Calibration Date	Test Date	Due Date	Remark
Notch Filter	Wainwright	WRCG824/849 -40/8SS	SN35	CDMA 850	Nov.07, 2018	May 10, 2019	Nov.06, 2019	Radiation (03CH15-HY)
Notch Filter	Wainwright	WRCT698/798 -10/40 8SSK	SN1	AWS Band	Nov.07, 2018	May 10, 2019	Nov.06, 2019	Radiation (03CH15-HY)
RF Cable	HUBER + SUHNER	SUCOFLEX 104	MY36980/4	30M-18G	Apr. 15, 2019	May 10, 2019	Apr. 14, 2020	Radiation (03CH15-HY)
RF Cable	HUBER + SUHNER	SUCOFLEX 104	MY9838/4	30M-18G	Apr. 15, 2019	May 10, 2019	Apr. 14, 2020	Radiation (03CH15-HY)
RF Cable	HUBER + SUHNER	MTJ	000000-MT18 A-100D3210	30M-18G	Apr. 15, 2019	May 10, 2019	Apr. 14, 2020	Radiation (03CH15-HY)

5 Uncertainty of Evaluation

<03CH07-HY>

Uncertainty of Radiated Emission Measurement (30 MHz ~ 1000 MHz)

Measuring Uncertainty for a Level of Confidence of 95% ($U = 2Uc(y)$)	3.05
---	------

Uncertainty of Radiated Emission Measurement (1 GHz ~ 18 GHz)

Measuring Uncertainty for a Level of Confidence of 95% ($U = 2Uc(y)$)	3.44
---	------

Uncertainty of Radiated Emission Measurement (18 GHz ~ 40 GHz)

Measuring Uncertainty for a Level of Confidence of 95% ($U = 2Uc(y)$)	3.95
---	------

<03CH15-HY>

Uncertainty of Radiated Emission Measurement (30 MHz ~ 1000 MHz)

Measuring Uncertainty for a Level of Confidence of 95% ($U = 2Uc(y)$)	3.17
---	------

Uncertainty of Radiated Emission Measurement (1 GHz ~ 18 GHz)

Measuring Uncertainty for a Level of Confidence of 95% ($U = 2Uc(y)$)	3.48
---	------

Uncertainty of Radiated Emission Measurement (18 GHz ~ 40 GHz)

Measuring Uncertainty for a Level of Confidence of 95% ($U = 2Uc(y)$)	4.00
---	------



Appendix A. Test Results of Radiated Test

Radiated Spurious Emission

Mode 1 Band 2 20M 1RB49 QPSK+Band5 10M 1RB24 QPSK

Band 2_20M 1RB49 QPSK+Band5_10M 1RB24 QPSK									
Channel	Frequency (MHz)	EIRP (dBm)	Limit (dBm)	Over Limit (dB)	SPA Reading (dBm)	S.G. Power (dBm)	TX Cable loss (dB)	TX Antenna Gain (dBi)	Polarization (H/V)
Middle	207	-74.15	-13	-61.15	-67.64	-74.70	0.34	0.89	H
	629.5	-72.63	-13	-59.63	-76.01	-72.12	0.61	0.10	H
	1043.5	-63.34	-13	-50.34	-73.92	-65.1	0.71	2.47	H
	1673	-61.81	-13	-48.81	-74.93	-65.64	0.99	4.82	H
	2509.5	-58.86	-13	-45.86	-77.31	-62.97	1.29	5.41	H
	3346	-56.91	-13	-43.91	-77.48	-62.68	1.56	7.32	H
	3553	-56.42	-13	-43.42	-77.65	-62.86	1.62	8.06	H
	3760	-53.19	-13	-40.19	-74.26	-59.82	1.69	8.31	H
	3967	-56.62	-13	-43.62	-77.56	-63.43	1.75	8.56	H
	4389	-56.38	-13	-43.38	-78.33	-63.07	1.99	8.68	H
	5640	-31.64	-13	-18.64	-57.21	-38.69	2.71	9.76	H
	6683.5	-50.54	-13	-37.54	-77.37	-58.27	2.69	10.42	H
	7313	-50.65	-13	-37.65	-77.92	-59.59	2.49	11.43	H
	7520	-50.05	-13	-37.05	-77.57	-59.44	2.42	11.81	H
	8356.5	-48.24	-13	-35.24	-77.09	-58.28	2.34	12.38	H



Middle	207	-74.37	-13	-61.37	-73.71	-74.92	0.34	0.89	V
	629.5	-69.98	-13	-56.98	-75.88	-69.47	0.61	0.10	V
	1043.5	-62.82	-13	-49.82	-73.72	-64.58	0.71	2.47	V
	1673	-61.04	-13	-48.04	-74.7	-64.87	0.99	4.82	V
	2509.5	-58.55	-13	-45.55	-77.49	-62.66	1.29	5.41	V
	3346	-56.66	-13	-43.66	-77.36	-62.43	1.56	7.32	V
	3553	-56.12	-13	-43.12	-77.25	-62.56	1.62	8.06	V
	3760	-53.74	-13	-40.74	-74.83	-60.37	1.69	8.31	V
	3967	-56.32	-13	-43.32	-77.32	-63.13	1.75	8.56	V
	4389	-56.28	-13	-43.28	-78.28	-62.97	1.99	8.68	V
	5640	-33.92	-13	-20.92	-59.49	-40.97	2.71	9.76	V
	6683.5	-50.75	-13	-37.75	-77.5	-58.48	2.69	10.42	V
	7313	-50.17	-13	-37.17	-77.61	-59.11	2.49	11.43	V
	7520	-49.77	-13	-36.77	-77.63	-59.16	2.42	11.81	V
	8356.5	-47.73	-13	-34.73	-77.05	-57.77	2.34	12.38	V

Remark: Spurious emissions within 30-1000MHz were found more than 20dB below limit line.



Mode 2 Band 4 20M 1RB49 QPSK+Band5 10M 1RB24 QPSK

Band 4_20M 1RB49 QPSK+Band5_10M 1RB24 QPSK									
Channel	Frequency (MHz)	EIRP (dBm)	Limit (dBm)	Over Limit (dB)	SPA Reading (dBm)	S.G. Power (dBm)	TX Cable loss (dB)	TX Antenna Gain (dBi)	Polarization (H/V)
Middle	59.5	-56.91	-13	-43.91	-53.48	-47.19	0.17	-9.55	H
	777	-70.28	-13	-57.28	-76.63	-69.62	0.64	-0.02	H
	896	-69.61	-13	-56.61	-77.56	-69.15	0.68	0.22	H
	1673	-61.19	-13	-48.19	-74.51	-65.02	0.99	4.82	H
	1792	-60.39	-13	-47.39	-74.83	-63.83	1.04	4.48	H
	2509.5	-58.51	-13	-45.51	-76.88	-62.62	1.29	5.41	H
	3346	-57.06	-13	-44.06	-77.57	-62.83	1.56	7.32	H
	3405.5	-57.91	-13	-44.91	-77.77	-63.92	1.57	7.58	H
	3465	-52.22	-13	-39.22	-73.36	-58.47	1.59	7.85	H
	3524.5	-56.44	-13	-43.44	-77.71	-62.86	1.61	8.03	H
	4242	-55.37	-13	-42.37	-76.98	-62.12	1.90	8.65	H
	5197.5	-35.41	-13	-22.41	-59.91	-42.66	2.45	9.70	H
	6093.5	-51.52	-13	-38.52	-78.06	-58.59	2.88	9.96	H
	6870.5	-50.99	-13	-37.99	-78	-59	2.63	10.64	H
	6930	-50.58	-13	-37.58	-77.75	-58.68	2.61	10.72	H
	7766.5	-48.25	-13	-35.25	-76.24	-57.87	2.34	11.96	H
									H



Middle	59.5	-56.42	-13	-43.42	-47.88	-46.70	0.17	-9.55	V
	777	-69.01	-13	-56.01	-76.8	-68.35	0.64	-0.02	V
	896	-67.41	-13	-54.41	-77.54	-66.95	0.68	0.22	V
	1673	-61.18	-13	-48.18	-74.95	-65.01	0.99	4.82	V
	1792	-59.54	-13	-46.54	-74.32	-62.98	1.04	4.48	V
	2509.5	-58.22	-13	-45.22	-77.01	-62.33	1.29	5.41	V
	3346	-56.66	-13	-43.66	-77.53	-62.43	1.56	7.32	V
	3405.5	-56.76	-13	-43.76	-77.7	-62.77	1.57	7.58	V
	3465	-52.77	-13	-39.77	-73.81	-59.02	1.59	7.85	V
	3524.5	-56.61	-13	-43.61	-77.68	-63.03	1.61	8.03	V
	4242	-55.12	-13	-42.12	-69.91	-61.87	1.90	8.65	V
	5197.5	-37.11	-13	-24.11	-61.44	-44.36	2.45	9.70	V
	6093.5	-51.46	-13	-38.46	-77.98	-58.53	2.88	9.96	V
	6870.5	-51.01	-13	-38.01	-78.08	-59.02	2.63	10.64	V
	6930	-50.47	-13	-37.47	-77.64	-58.57	2.61	10.72	V
	7766.5	-48.26	-13	-35.26	-76.6	-57.88	2.34	11.96	V
								V	

Remark: Spurious emissions within 30-1000MHz were found more than 20dB below limit line.



Mode 3 Band 2 20M 1RB49 QPSK+Band13 10M 1RB24 QPSK

Band 2_20M 1RB49 QPSK+Band13_10M 1RB24 QPSK									
Channel	Frequency (MHz)	EIRP (dBm)	Limit (dBm)	Over Limit (dB)	SPA Reading (dBm)	S.G. Power (dBm)	TX Cable loss (dB)	TX Antenna Gain (dBi)	Polarization (H/V)
Middle	466	-74.70	-13	-61.70	-76.1	-74.32	0.50	0.12	H
	1248	-63.02	-13	-50.02	-73.85	-65.96	0.80	3.74	H
	1414	-63.19	-13	-50.19	-74.56	-67.08	0.87	4.77	H
	1564	-63.25	-40	-23.25	-75.41	-67.43	0.94	5.12	H
	2346	-59.31	-13	-46.31	-77	-63.01	1.24	4.94	H
	2662	-58.62	-13	-45.62	-77.18	-62.81	1.34	5.53	H
	2978	-58.15	-13	-45.15	-77.38	-62.49	1.44	5.78	H
	3128	-57.65	-13	-44.65	-77.16	-62.53	1.49	6.36	H
	3760	-56.74	-13	-43.74	-77.81	-63.37	1.69	8.31	H
	4542	-55.12	-13	-42.12	-77.56	-61.83	2.07	8.78	H
	5008	-53.75	-13	-40.75	-77.78	-61.11	2.34	9.70	H
	5324	-52.71	-13	-39.71	-77.58	-59.89	2.52	9.70	H
	5640	-52.78	-13	-39.78	-77.43	-59.83	2.71	9.76	H
	6106	-51.76	-13	-38.76	-78.33	-58.84	2.88	9.96	H
	6422	-50.63	-13	-37.63	-77.36	-58.01	2.78	10.15	H
7520	-49.77	-13	-36.77	-77.34	-59.16	2.42	11.81	H	



Middle	466	-74.55	-13	-61.55	-76.6	-74.17	0.50	0.12	V
	1248	-62.73	-13	-49.73	-73.94	-65.67	0.80	3.74	V
	1414	-62.93	-13	-49.93	-74.79	-66.82	0.87	4.77	V
	1564	-62.81	-40	-22.81	-75.54	-66.99	0.94	5.12	V
	2346	-58.52	-13	-45.52	-76.65	-62.22	1.24	4.94	V
	2662	-57.74	-13	-44.74	-76.9	-61.93	1.34	5.53	V
	2978	-57.13	-13	-44.13	-77.22	-61.47	1.44	5.78	V
	3128	-55.54	-13	-42.54	-75.76	-60.42	1.49	6.36	V
	3760	-57.19	-13	-44.19	-78.24	-63.82	1.69	8.31	V
	4542	-55.58	-13	-42.58	-78.02	-62.29	2.07	8.78	V
	5008	-54.02	-13	-41.02	-78.02	-61.38	2.34	9.70	V
	5324	-52.83	-13	-39.83	-77.56	-60.01	2.52	9.70	V
	5640	-51.74	-13	-38.74	-77.39	-58.79	2.71	9.76	V
	6106	-52.07	-13	-39.07	-78.46	-59.15	2.88	9.96	V
	6422	-50.75	-13	-37.75	-77.26	-58.13	2.78	10.15	V
7520	-49.93	-13	-36.93	-77.7	-59.32	2.42	11.81	V	

Remark: Spurious emissions within 30-1000MHz were found more than 20dB below limit line.



Mode 4 Band 4 20M 1RB49 QPSK+Band13 10M 1RB24 QPSK

Band 4_20M 1RB49 QPSK+Band13_10M 1RB24 QPSK									
Channel	Frequency (MHz)	EIRP (dBm)	Limit (dBm)	Over Limit (dB)	SPA Reading (dBm)	S.G. Power (dBm)	TX Cable loss (dB)	TX Antenna Gain (dBi)	Polarization (H/V)
Middle	1119	-63.09	-13	-50.09	-73.57	-65.28	0.74	2.94	H
	1395.5	-63.16	-13	-50.16	-74.44	-66.94	0.87	4.65	H
	1564	-63.17	-40	-23.17	-75.45	-67.35	0.94	5.12	H
	2346	-59.00	-13	-46.00	-76.68	-62.7	1.24	4.94	H
	2514.5	-57.44	-13	-44.44	-75.87	-61.56	1.30	5.41	H
	2683	-57.81	-13	-44.81	-76.51	-62.01	1.35	5.55	H
	3128	-57.28	-13	-44.28	-76.82	-62.16	1.49	6.36	H
	3465	-51.41	-13	-38.41	-72.54	-57.66	1.59	7.85	H
	4247	-55.16	-13	-42.16	-76.75	-61.91	1.90	8.65	H
	4415.5	-56.52	-13	-43.52	-78.58	-63.2	2.00	8.68	H
	4860.5	-53.39	-13	-40.39	-76.91	-60.55	2.26	9.42	H
	5029	-53.48	-13	-40.48	-77.56	-60.83	2.35	9.70	H
	5197.5	-53.10	-13	-40.10	-77.61	-60.35	2.45	9.70	H
	5811	-51.24	-13	-38.24	-77.25	-58.26	2.80	9.82	H
	5979.5	-51.86	-13	-38.86	-78.24	-58.85	2.90	9.89	H
6930	-50.67	-13	-37.67	-77.84	-58.77	2.61	10.72	H	



Middle	1119	-62.94	-13	-49.94	-73.66	-65.13	0.74	2.94	V
	1395.5	-62.43	-13	-49.43	-74.17	-66.21	0.87	4.65	V
	1564	-62.53	-40	-22.53	-75.31	-66.71	0.94	5.12	V
	2346	-58.68	-13	-45.68	-76.77	-62.38	1.24	4.94	V
	2514.5	-57.42	-13	-44.42	-76.13	-61.54	1.30	5.41	V
	2683	-57.24	-13	-44.24	-76.59	-61.44	1.35	5.55	V
	3128	-56.33	-13	-43.33	-76.59	-61.21	1.49	6.36	V
	3465	-56.41	-13	-43.41	-77.46	-62.66	1.59	7.85	V
	4247	-55.29	-13	-42.29	-77.01	-62.04	1.90	8.65	V
	4415.5	-56.19	-13	-43.19	-78.34	-62.87	2.00	8.68	V
	4860.5	-53.88	-13	-40.88	-77.27	-61.04	2.26	9.42	V
	5029	-53.84	-13	-40.84	-77.73	-61.19	2.35	9.70	V
	5197.5	-53.21	-13	-40.21	-77.58	-60.46	2.45	9.70	V
	5811	-50.90	-13	-37.90	-76.91	-57.92	2.80	9.82	V
	5979.5	-51.81	-13	-38.81	-78.21	-58.8	2.90	9.89	V
	6930	-50.50	-13	-37.50	-77.67	-58.6	2.61	10.72	V

Remark: Spurious emissions within 30-1000MHz were found more than 20dB below limit line.