



# FCC RADIO TEST REPORT

**FCC ID** : PKRISGMD2000  
**Equipment** : Wireless Module  
**Brand Name** : Inseego  
**Model Name** : MD2000  
**Applicant** : Inseego Corporation  
9710 Scranton Road Suite 200, San Diego, CA 92121  
**Manufacturer** : Inseego Corporation  
9710 Scranton Road Suite 200, San Diego, CA 92121  
**Standard** : FCC Part 15 Subpart C §15.247

The product was received on Sep. 11, 2020 and testing was started from Sep. 22, 2020 and completed on Sep. 29, 2020. We, SPORTON INTERNATIONAL INC., EMC & Wireless Communications Laboratory, would like to declare that the tested sample has been evaluated in accordance with the test procedures and has been in compliance with the applicable technical standards.

The test results in this report apply exclusively to the tested model / sample. Without written approval of SPORTON INTERNATIONAL INC. EMC & Wireless Communications Laboratory, the test report shall not be reproduced except in full.

*Louis Wu*

Approved by: Louis Wu

**SPORTON INTERNATIONAL INC. EMC & Wireless Communications Laboratory**

No. 52, Huaya 1st Rd., Guishan Dist., Taoyuan City, Taiwan (R.O.C.)



## Table of Contents

**History of this test report..... 3**

**Summary of Test Result..... 4**

**1 General Description ..... 5**

    1.1 Product Feature of Equipment Under Test..... 5

    1.2 Modification of EUT ..... 5

    1.3 Testing Location ..... 5

    1.4 Applicable Standards..... 6

**2 Test Configuration of Equipment Under Test ..... 7**

    2.1 Carrier Frequency and Channel ..... 7

    2.2 Test Mode..... 8

    2.3 Connection Diagram of Test System..... 9

    2.4 Support Unit used in test configuration and system ..... 9

    2.5 EUT Operation Test Setup ..... 10

    2.6 Measurement Results Explanation Example..... 10

**3 Test Result ..... 11**

    3.1 6dB and 99% Bandwidth Measurement ..... 11

    3.2 Output Power Measurement..... 13

    3.3 Power Spectral Density Measurement ..... 14

    3.4 Conducted Band Edges and Spurious Emission Measurement ..... 17

    3.5 Radiated Band Edges and Spurious Emission Measurement ..... 42

    3.6 Antenna Requirements ..... 46

**4 List of Measuring Equipment..... 47**

**5 Uncertainty of Evaluation ..... 48**

**Appendix A. Conducted Test Results**

**Appendix B. Radiated Spurious Emission**

**Appendix C. Radiated Spurious Emission Plots**

**Appendix D. Duty Cycle Plots**

**Appendix E. Setup Photographs**





### Summary of Test Result

Report Clause	Ref Std. Clause	Test Items	Result (PASS/FAIL)	Remark
3.1	15.247(a)(2)	6dB Bandwidth	Pass	-
3.1	2.1049	99% Occupied Bandwidth	Reporting only	-
3.2	15.247(b)	Power Output Measurement	Pass	-
3.3	15.247(e)	Power Spectral Density	Pass	-
3.4	15.247(d)	Conducted Band Edges	Pass	-
		Conducted Spurious Emission	Pass	-
3.5	15.247(d)	Radiated Band Edges and Radiated Spurious Emission	Pass	Under limit 0.19 dB at 2485.680 MHz
-	15.207	AC Conducted Emission	Not Required	-
3.6	15.203 & 15.247(b)	Antenna Requirement	Pass	-

**Note:** Not required means after assessing, test items are not necessary to carry out.

<b>Declaration of Conformity:</b>
The test results with all measurement uncertainty excluded are presented in accordance with the regulation limits or requirements declared by manufacturers.
<b>Comments and Explanations:</b>
The declared of product specification for EUT presented in the report are provided by the manufacturer, and the manufacturer takes all the responsibilities for the accuracy of product specification.

**Reviewed by: Wii Chang**  
**Report Producer: Lucy Wu**



# 1 General Description

## 1.1 Product Feature of Equipment Under Test

WCDMA/LTE/5G NR, Wi-Fi 2.4GHz 802.11b/g/n/ac/ax, Wi-Fi 5GHz 802.11a/n/ac/ax, and GNSS.

Product Specification subjective to this standard	
Antenna Type	WWAN: Monopole Antenna WLAN <Ant. 0>: Monopole Antenna <Ant. 1>: Monopole Antenna GPS / Glonass / BDS / Galileo: Monopole Antenna

## 1.2 Modification of EUT

No modifications are made to the EUT during all test items.

## 1.3 Testing Location

Test Site	SPORTON INTERNATIONAL INC. EMC & Wireless Communications Laboratory
Test Site Location	No.52, Huaya 1st Rd., Guishan Dist., Taoyuan City, Taiwan (R.O.C.) TEL: +886-3-327-3456 FAX: +886-3-328-4978
Test Site No.	<b>Sporton Site No.</b> TH05-HY

Test Site	SPORTON INTERNATIONAL INC. EMC & Wireless Communications Laboratory
Test Site Location	No.58, Aly. 75, Ln. 564, Wenhua 3rd, Rd., Guishan Dist., Taoyuan City, Taiwan (R.O.C.) TEL: +886-3-327-0868 FAX: +886-3-327-0855
Test Site No.	<b>Sporton Site No.</b> 03CH15-HY

**Note:** The test site complies with ANSI C63.4 2014 requirement.

FCC designation No.: TW1190 and TW0007



## **1.4 Applicable Standards**

According to the specifications of the manufacturer, the EUT must comply with the requirements of the following standards:

- ♦ FCC Part 15 Subpart C §15.247
- ♦ FCC KDB Publication No. 558074 D01 DTS Meas. Guidance v05r02
- ♦ FCC KDB 414788 D01 Radiated Test Site v01r01.
- ♦ FCC KDB 662911 D01 Multiple Transmitter Output v02r01.
- ♦ ANSI C63.10-2013

**Remark:**

1. All test items were verified and recorded according to the standards and without any deviation during the test.
2. The TAF code is not including all the FCC KDB listed without accreditation.
3. This EUT has also been tested and complied with the requirements of FCC Part 15, Subpart B, recorded in a separate test report.



## 2 Test Configuration of Equipment Under Test

The EUT has been associated with peripherals and configuration operated in a manner tended to maximize its emission characteristics in a typical application. Frequency range investigated: radiation emission (9 kHz to the 10th harmonic of the highest fundamental frequency or to 40 GHz, whichever is lower). For radiated measurement, pre-scanned in two degrees (0 and 90). The worst cases (Degree 0) were recorded in this report.

### 2.1 Carrier Frequency and Channel

Frequency Band	Channel	Freq. (MHz)	Channel	Freq. (MHz)
2400-2483.5 MHz	1	2412	7	2442
	2	2417	8	2447
	3	2422	9	2452
	4	2427	10	2457
	5	2432	11	2462
	6	2437		



## 2.2 Test Mode

Final test modes are considering the modulation and worse data rates as below table.

The CDD mode is chosen as worst case configuration for all test cases due to higher power than SISO mode.

Modulation	Data Rate
802.11b	1 Mbps
802.11g	6 Mbps
802.11n HT20 (Covered by HE20)	MCS0
802.11n HT40 (Covered by HE40)	MCS0
802.11ac VHT20 (Covered by HE20)	MCS0
802.11ac VHT40 (Covered by HE40)	MCS0
802.11ax HE20	MCS0
802.11ax HE40	MCS0

Ch. #	2400-2483.5 MHz			
	802.11b	802.11g	802.11ax HE20	802.11ax HE40
Low	01	01	01	03
Middle	06	06	-	-
High	11	11	11	09

**Remark:** For radiation spurious emission, the final modulation and the worst data rate was reference the max RF conducted power.



### 2.3 Connection Diagram of Test System

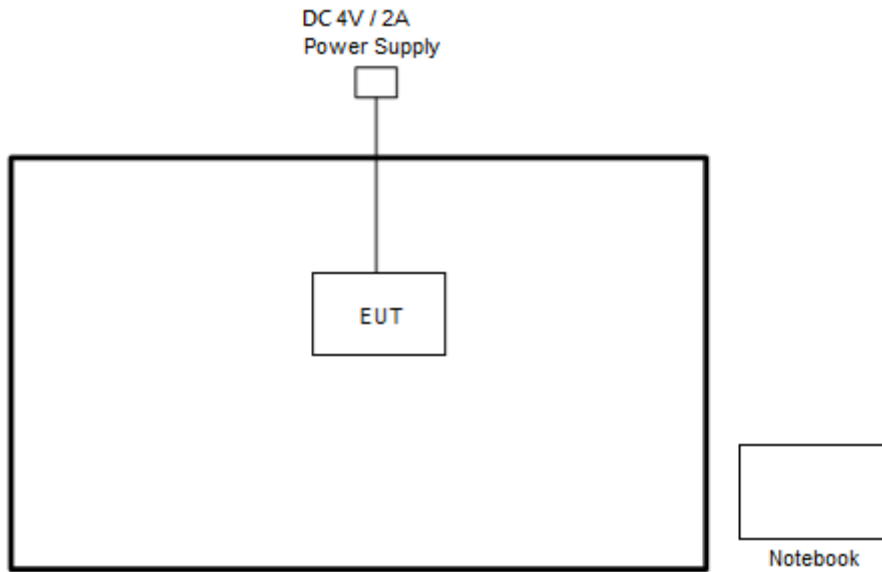

### 2.4 Support Unit used in test configuration and system

Item	Equipment	Brand Name	Model Name	FCC ID	Data Cable	Power Cord
1.	Power Supply	GW Instek	GPE-2323	N/A	N/A	Unshielded, 1.8 m
2.	Notebook	HP	15-cs3019nr	N/A	N/A	AC I/P: Unshielded, 1.2 m DC O/P: Shielded, 1.8 m



## 2.5 EUT Operation Test Setup

The RF test items, utility “QRCT 4.0.00172.0” was installed in Notebook which was programmed in order to make the EUT get into the engineering modes to provide channel selection, power level, data rate and the application type and for continuous transmitting signals.

## 2.6 Measurement Results Explanation Example

**For all conducted test items:**

The offset level is set in the spectrum analyzer to compensate the RF cable loss and attenuator factor between EUT conducted output port and spectrum analyzer. With the offset compensation, the spectrum analyzer reading level is exactly the EUT RF output level.

Example:

The spectrum analyzer offset is derived from RF cable loss and attenuator factor.

*Offset = RF cable loss + attenuator factor.*

Following shows an offset computation example with cable loss 4.2 dB and 10dB attenuator.

$$\begin{aligned} \text{Offset}(dB) &= \text{RF cable loss}(dB) + \text{attenuator factor}(dB). \\ &= 4.2 + 10 = 14.2 \text{ (dB)} \end{aligned}$$

### 3 Test Result

#### 3.1 6dB and 99% Bandwidth Measurement

##### 3.1.1 Limit of 6dB and 99% Bandwidth

The minimum 6 dB bandwidth shall be at least 500 kHz.

##### 3.1.2 Measuring Instruments

See list of measuring equipment of this test report.

##### 3.1.3 Test Procedures

1. The testing follows the ANSI C63.10 Section 6.9.3 (OBW) and 11.8.1 (6dB BW).
2. The RF output of EUT was connected to the spectrum analyzer by RF cable and attenuator. The path loss was compensated to the results for each measurement.
3. Set to the maximum power setting and enable the EUT transmit continuously.
4. Make the measurement with the spectrum analyzer's resolution bandwidth (RBW) = 100 kHz. Set the Video bandwidth (VBW) = 300 kHz. In order to make an accurate measurement. The 6 dB bandwidth must be greater than 500 kHz.
5. For 99% Bandwidth Measurement, the spectrum analyzer's resolution bandwidth (RBW) is set 1-5% of the emission bandwidth and set the Video bandwidth (VBW)  $\geq 3 * RBW$ .
6. Measure and record the results in the test report.

##### 3.1.4 Test Setup

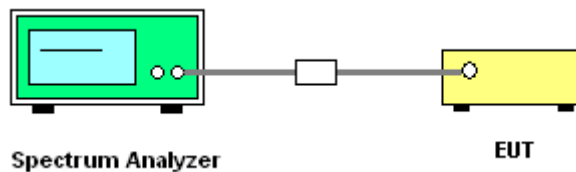



### 3.1.5 Test Result of 6dB and 99% Occupied Bandwidth

Please refer to Appendix A.

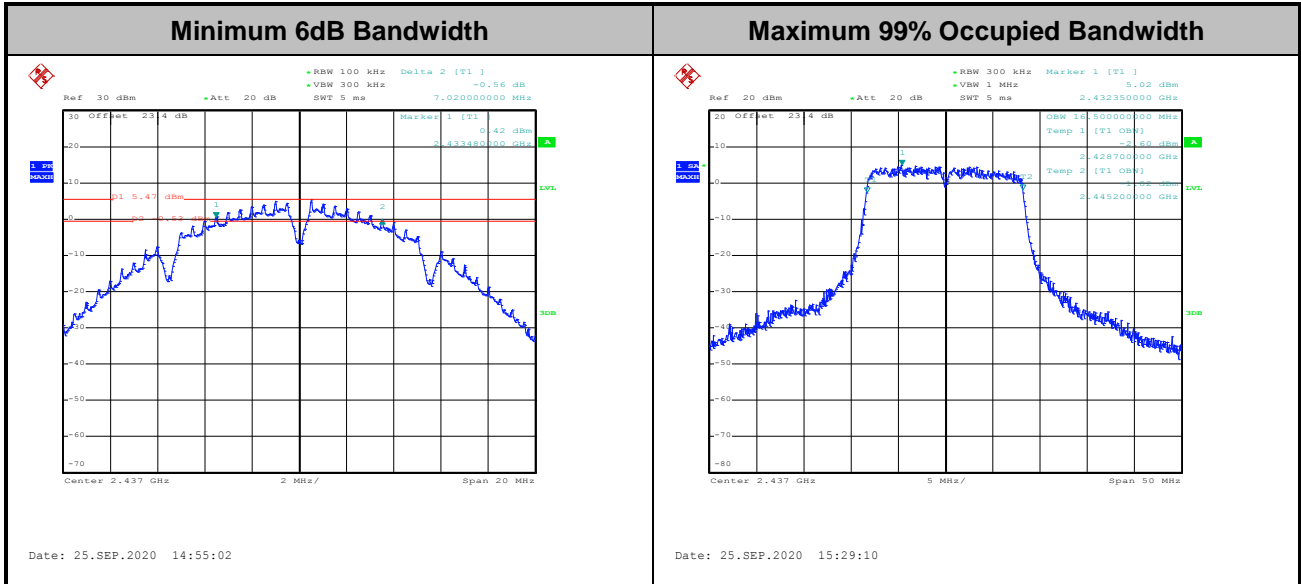

Note: The occupied channel bandwidth is maintained within the band of operation for all of the modulations.

<For 802.11ax Mode>

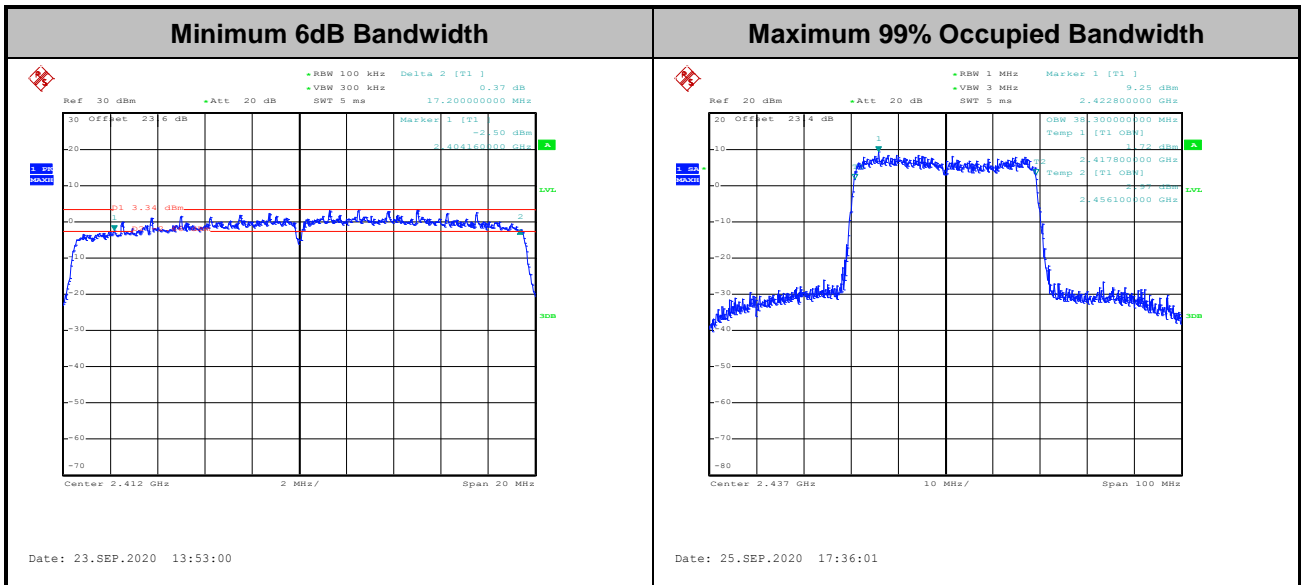

Note: The occupied channel bandwidth is maintained within the band of operation for all of the modulations.

## 3.2 Output Power Measurement

### 3.2.1 Limit of Output Power

For systems using digital modulation in the 2400-2483.5MHz, the limit for output power is 30dBm. If transmitting antenna with directional gain greater than 6dBi is used, the peak output power from the intentional radiator shall be reduced below the above stated value by the amount in dB that the directional gain of the antenna exceeds 6 dBi. In case of point-to-point operation, the limit has to be reduced by 1dB for every 3dB that the directional gain of the antenna exceeds 6dBi.

### 3.2.2 Measuring Instruments

See list of measuring equipment of this test report.

### 3.2.3 Test Procedures

1. For Average Power, the testing follows ANSI C63.10 Section 11.9.2.3.2 Method AVGPM-G
2. The RF output of EUT was connected to the power meter by RF cable and attenuator. The path loss was compensated to the results for each measurement.
3. Set to the maximum power setting and enable the EUT transmit continuously.
4. Measure the conducted output power and record the results in the test report.
5. For MIMO mode, calculation method follows FCC KDB 662911 D01 Multiple Transmitter Output v02r01.

### 3.2.4 Test Setup

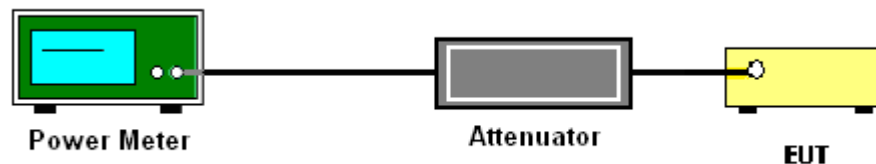

### 3.2.5 Test Result of Average Output Power

Please refer to Appendix A.

### 3.3 Power Spectral Density Measurement

#### 3.3.1 Limit of Power Spectral Density

The peak power spectral density shall not be greater than 8dBm in any 3kHz band at any time interval of continuous transmission.

#### 3.3.2 Measuring Instruments

See list of measuring equipment of this test report.

#### 3.3.3 Test Procedures

1. The testing follows the ANSI C63.10 Section 11.10.2 Method PKPSD.
2. The RF output of EUT was connected to the spectrum analyzer by RF cable and attenuator. The path loss was compensated to the results for each measurement.
3. Set to the maximum power setting and enable the EUT transmit continuously.
4. Make the measurement with the spectrum analyzer's resolution bandwidth (RBW) = 3 kHz. Video bandwidth VBW = 10 kHz In order to make an accurate measurement, set the span to 1.5 times DTS Channel Bandwidth. (6dB BW)
5. Detector = peak, Sweep time = auto couple, Trace mode = max hold, Allow trace to fully stabilize. Use the peak marker function to determine the maximum power level.
6. Measure and record the results in the test report.
7. For MIMO mode, calculation method follows FCC KDB 662911 D01 Multiple Transmitter Output v02r01.

If measurements performed using method (2) plus  $10 \log(N)$  exceeds the emission limit, the test should choose method (1) before declaring that the device fails the emission limit.

Method (1): Measure and sum the spectra across the outputs.

The total final Power Spectral Density is from a device with 2 transmitter outputs. The spectrum measurements of the individual outputs are all performed with the same span and number of points, the spectrum value in the first spectral bin of output 1 is summed with that in the first spectral bin of output 2 to obtain the value for the first frequency bin of the summed spectrum.

Method (2): Measure and add  $10 \log(N)$  dB, where N is the number of outputs. (N=2)

#### 3.3.4 Test Setup

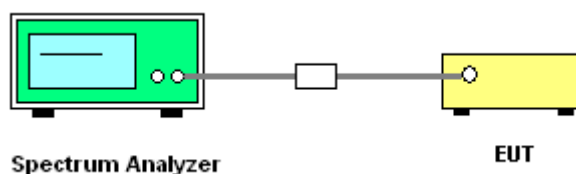



### 3.3.5 Test Result of Power Spectral Density

Please refer to Appendix A.

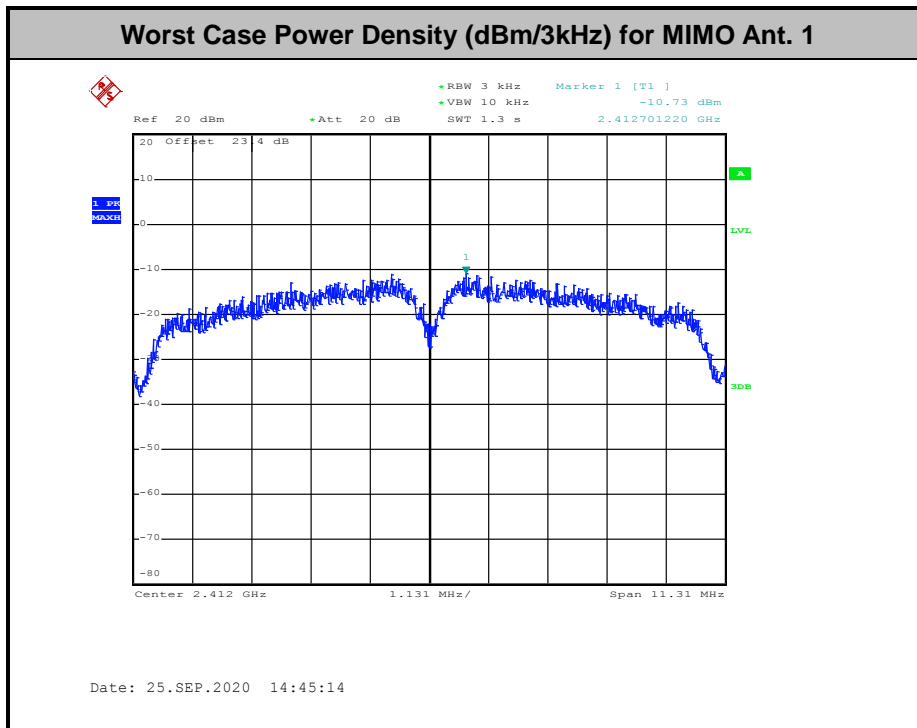
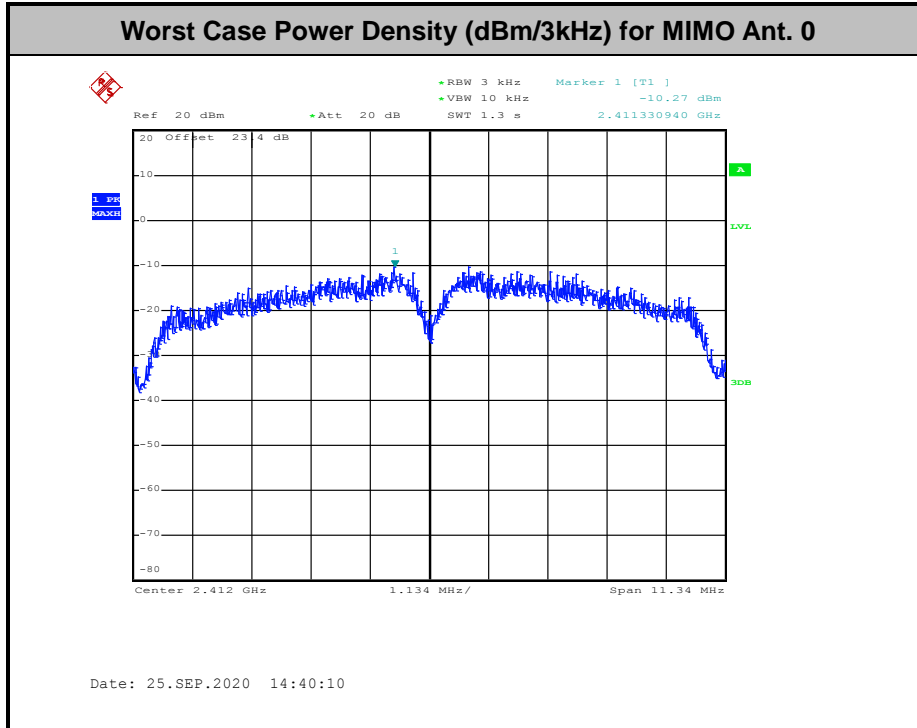



<For 802.11ax Mode>

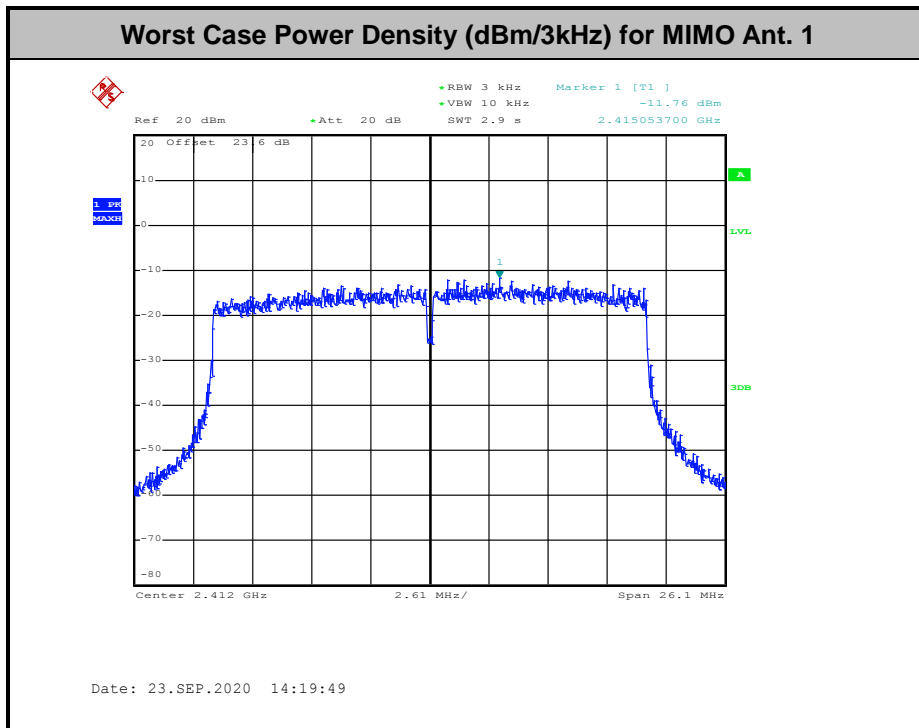
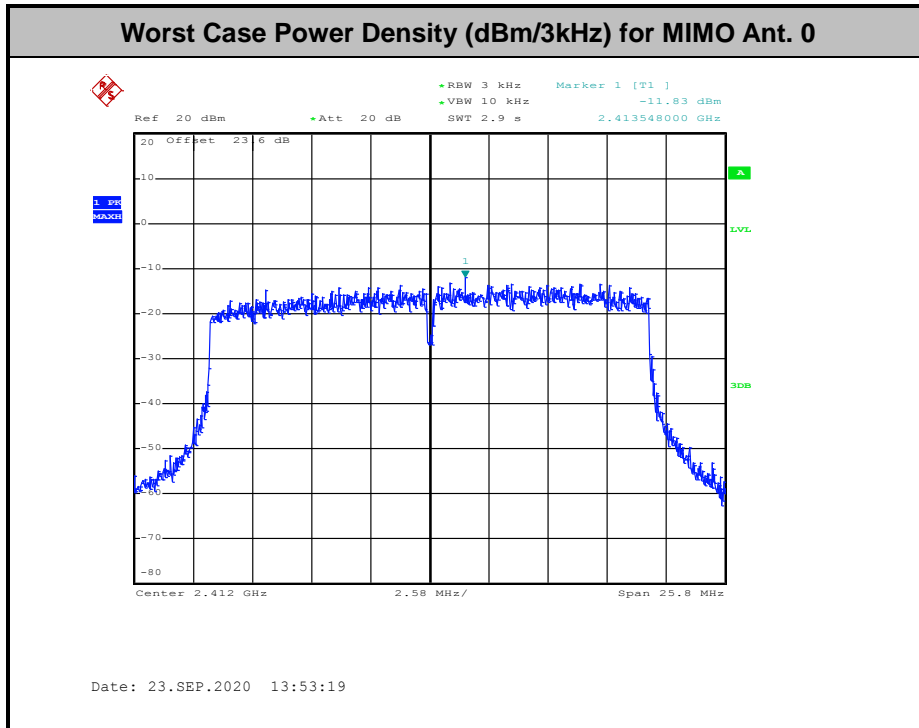



## 3.4 Conducted Band Edges and Spurious Emission Measurement

### 3.4.1 Limit of Conducted Band Edges and Spurious Emission Measurement

In any 100 kHz bandwidth outside of the authorized frequency band, the emissions which fall in the non-restricted bands shall be attenuated at least 20 dB / 30dB relative to the maximum PSD level in 100 kHz by RF conducted measurement.

### 3.4.2 Measuring Instruments

See list of measuring equipment of this test report.

### 3.4.3 Test Procedures

1. The testing follows the ANSI C63.10 Section 11.11.3 Emission level measurement.
2. The RF output of EUT was connected to the spectrum analyzer by RF cable and attenuator. The path loss was compensated to the results for each measurement.
3. Set to the maximum power setting and enable the EUT transmit continuously.
4. Set RBW = 100 kHz, VBW=300 kHz, Peak Detector. Unwanted Emissions measured in any 100 kHz bandwidth outside of the authorized frequency band shall be attenuated by at least 20 dB relative to the maximum in-band peak PSD level in 100 kHz when maximum peak conducted output power procedure is used. If the transmitter complies with the conducted power limits based on the use of RMS averaging over a time interval, the attenuation required under this paragraph shall be 30 dB instead of 20 dB per 15.247(d).
5. Measure and record the results in the test report.
6. The RF fundamental frequency should be excluded against the limit line in the operating frequency band.

### 3.4.4 Test Setup

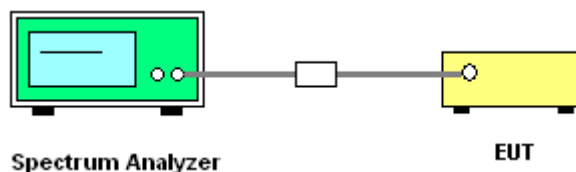



### 3.4.5 Test Result of Conducted Band Edges and Spurious Emission

Test Engineer : Mina Liu	Temperature :	23.6~23.7°C
	Relative Humidity :	53.5~54.1%

Number of TX = 2, Ant. 0 (Measured)

Test Mode :	802.11b	Test Channel :	01
-------------	---------	----------------	----

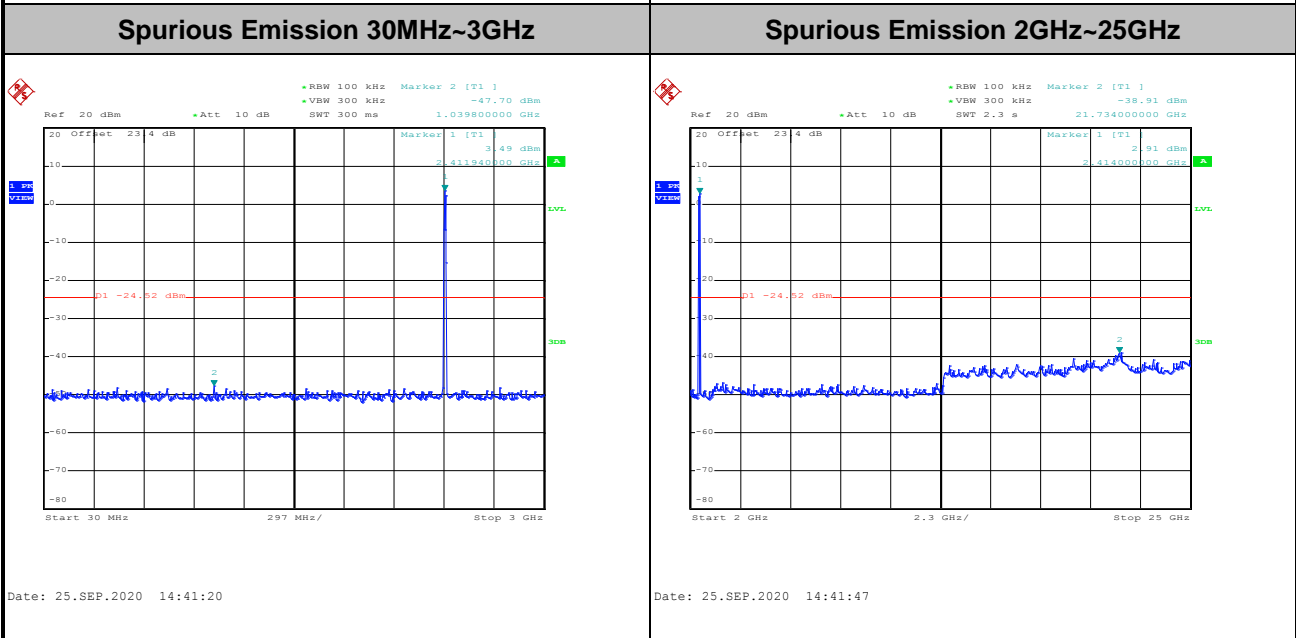
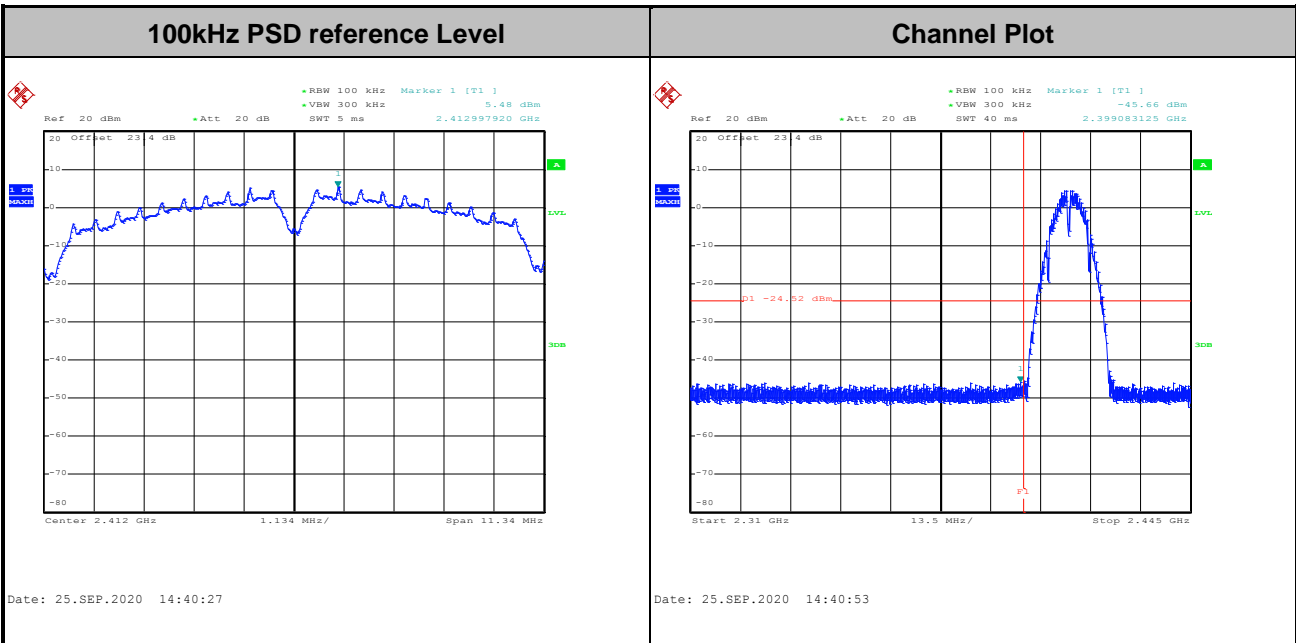



Test Mode :	802.11b	Test Channel :	06
-------------	---------	----------------	----

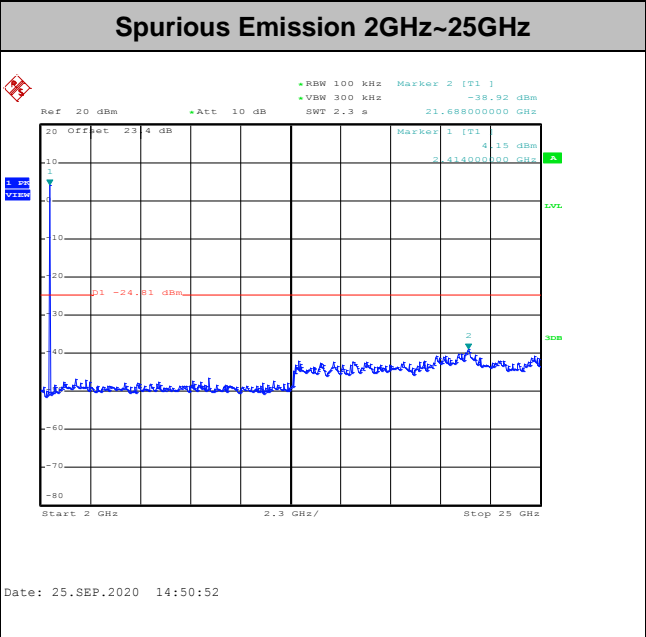
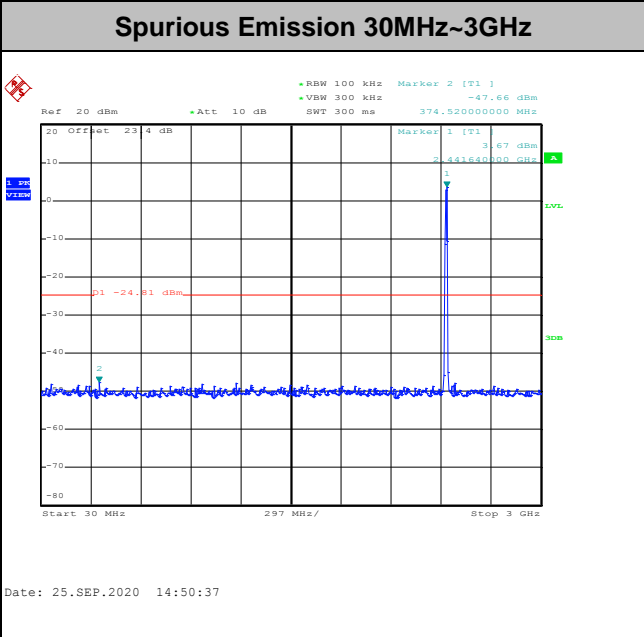
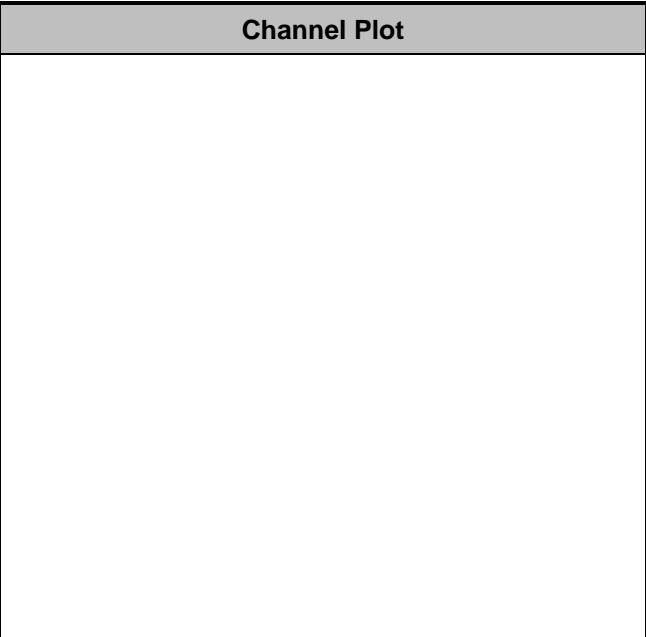
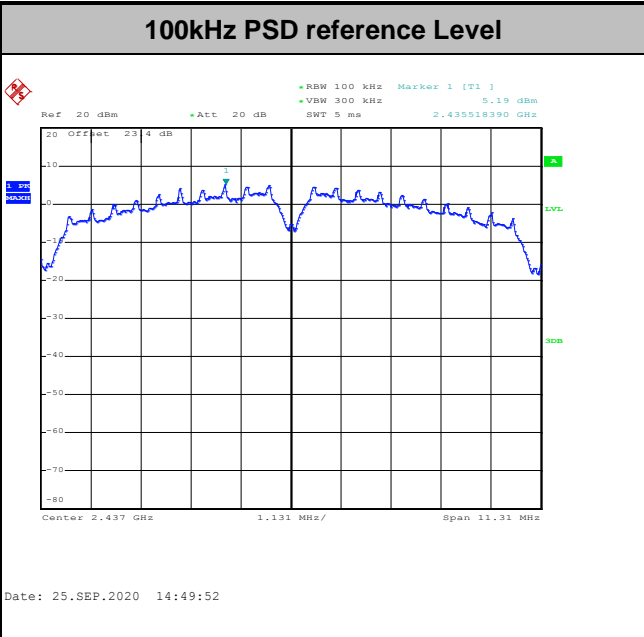



Test Mode :	802.11b	Test Channel :	11
-------------	---------	----------------	----

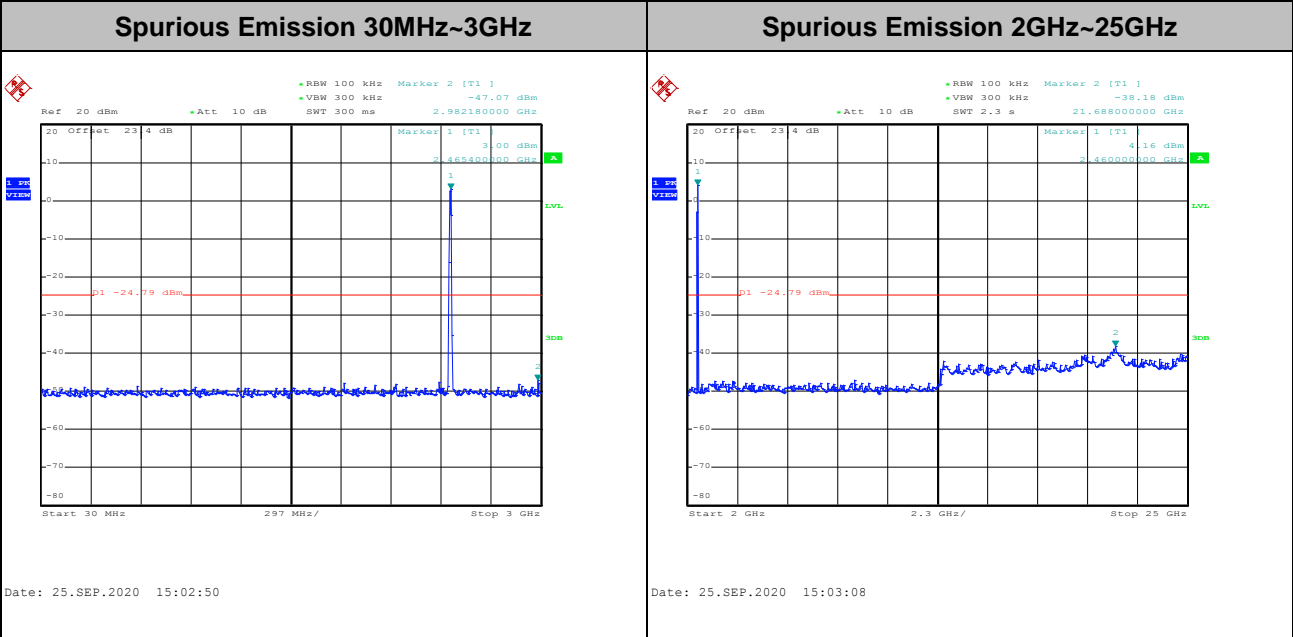
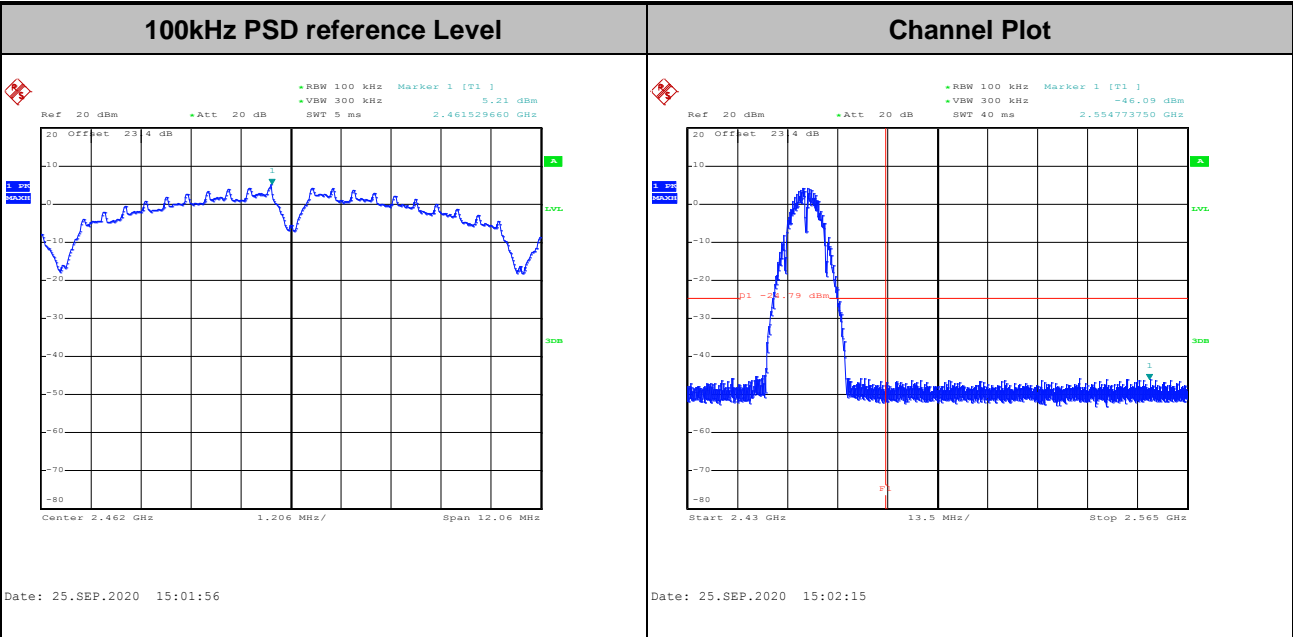



Test Mode : 802.11g Test Channel : 01

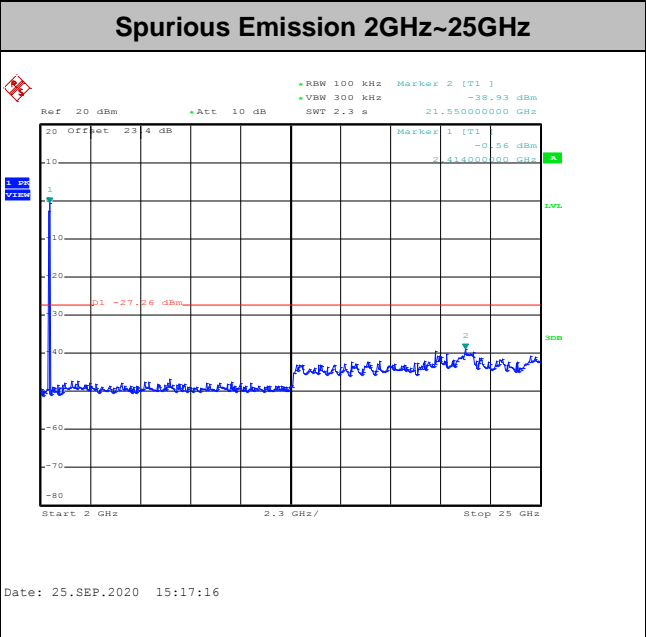
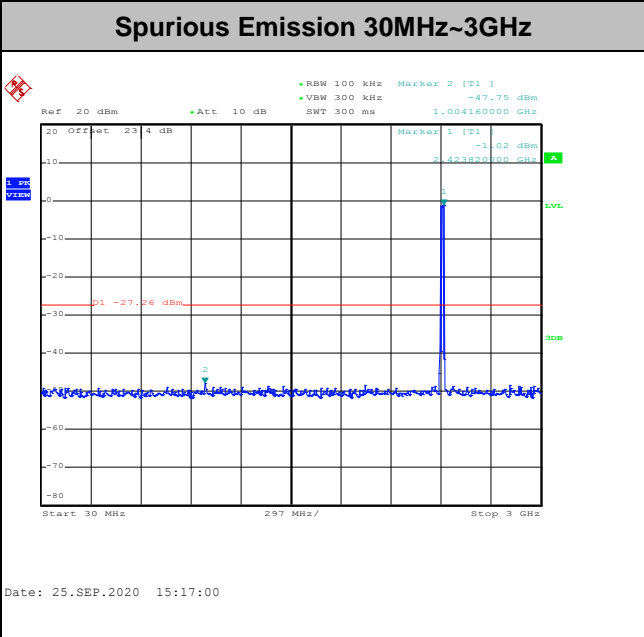
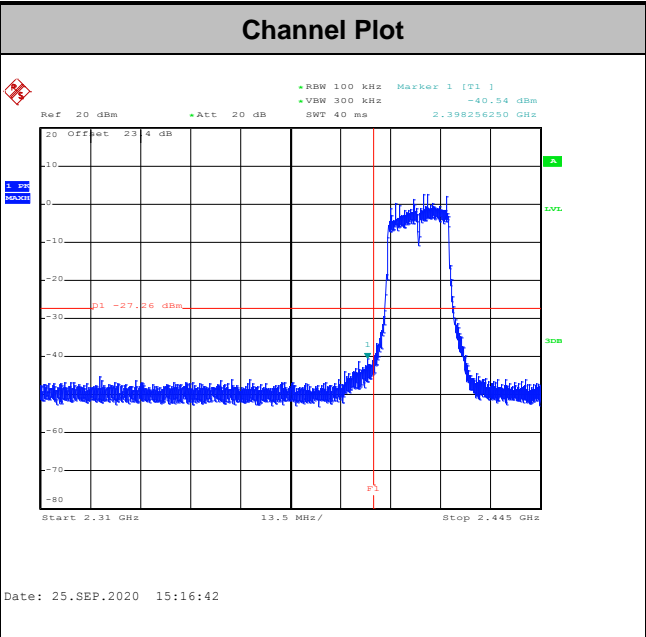
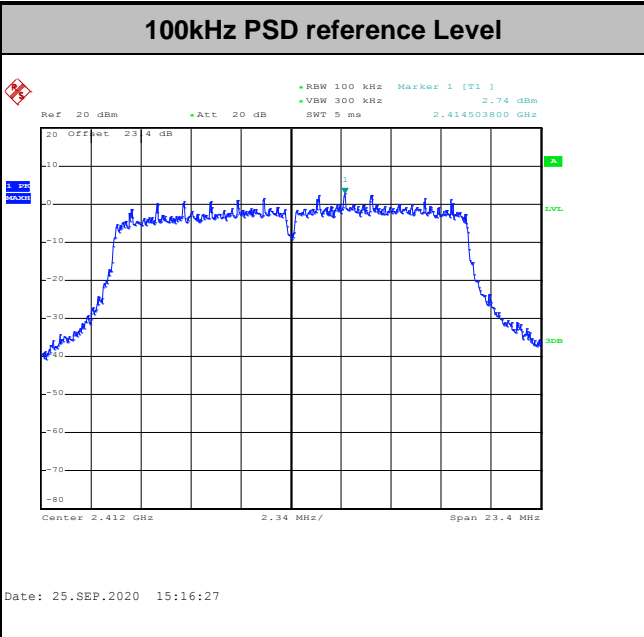



Test Mode :	802.11g	Test Channel :	06
-------------	---------	----------------	----

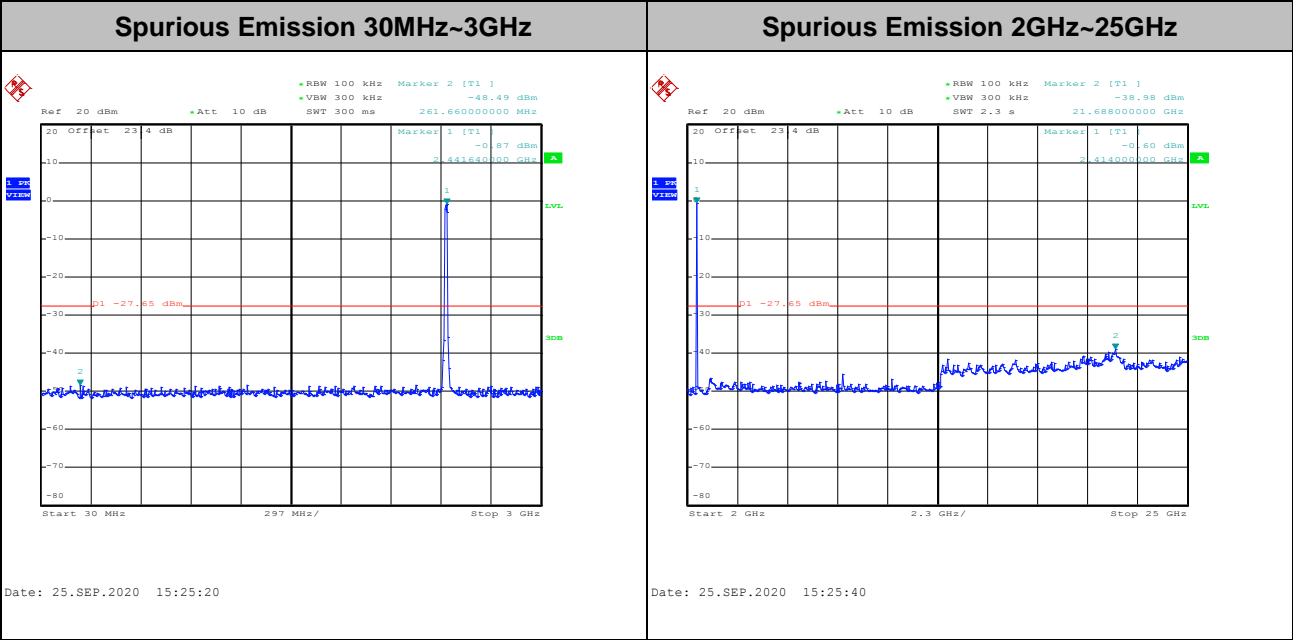
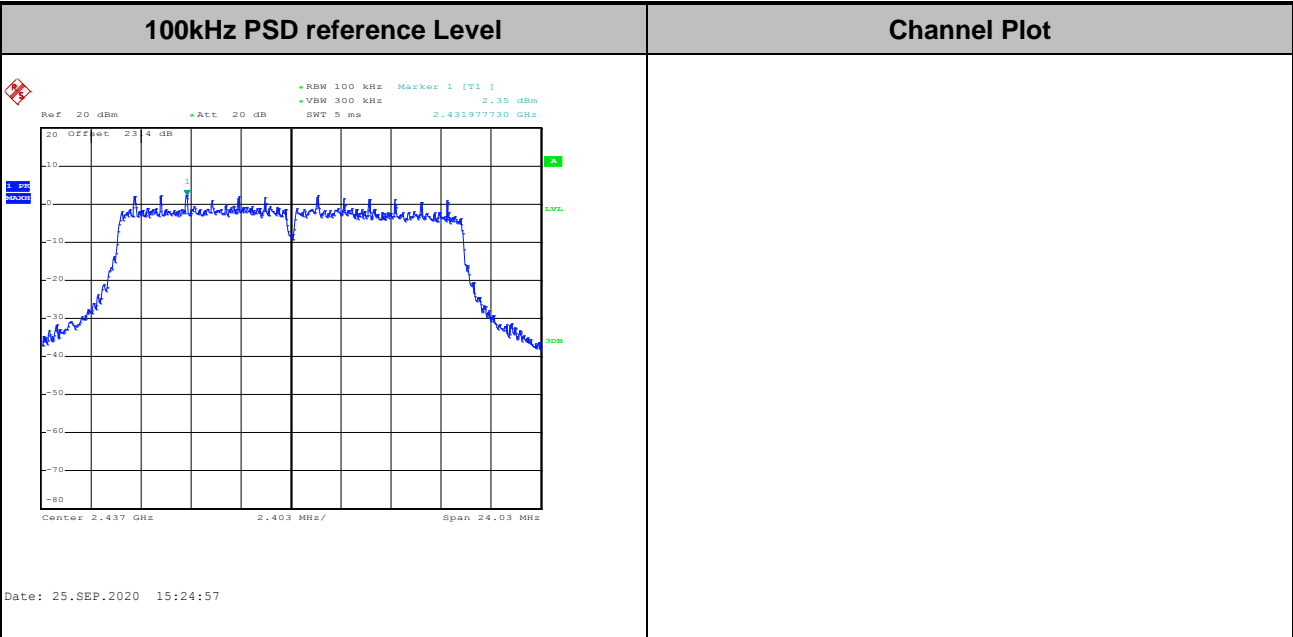



Test Mode :	802.11g	Test Channel :	11
-------------	---------	----------------	----

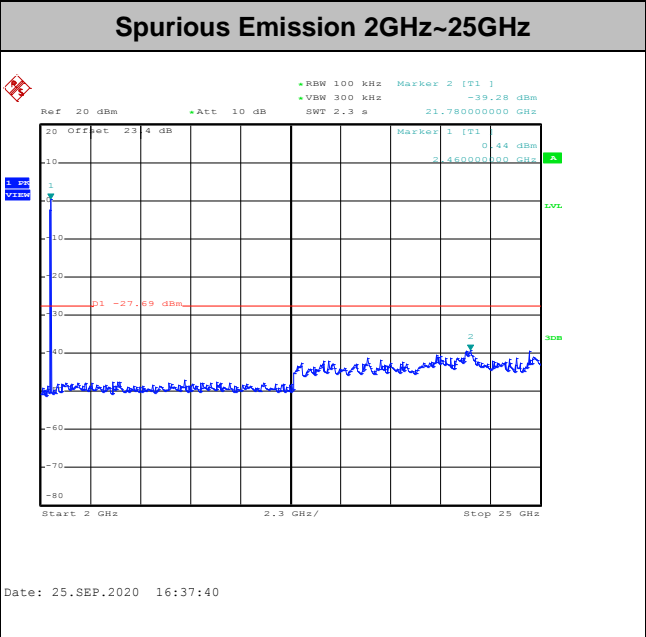
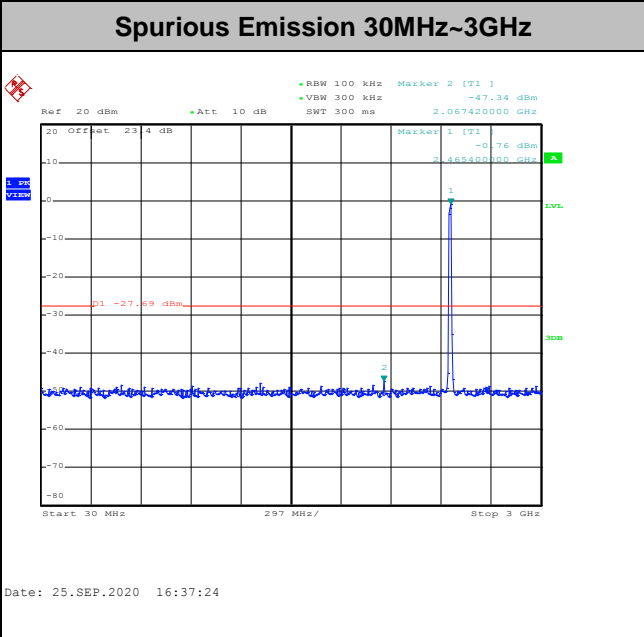
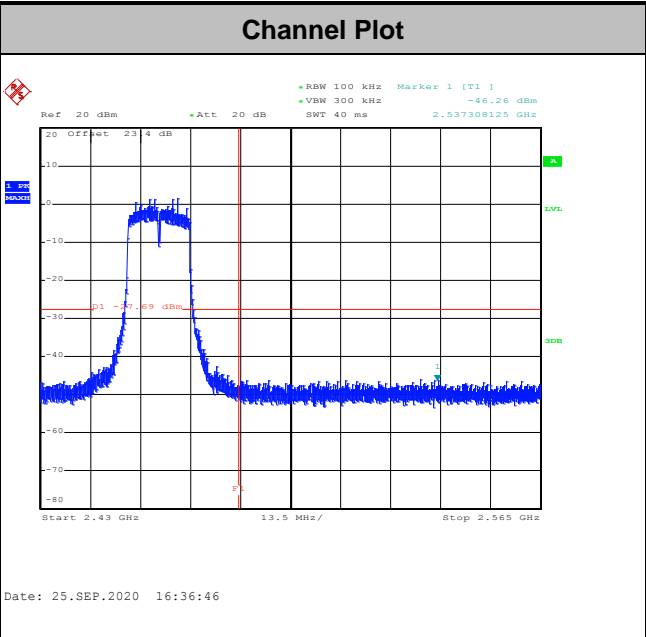
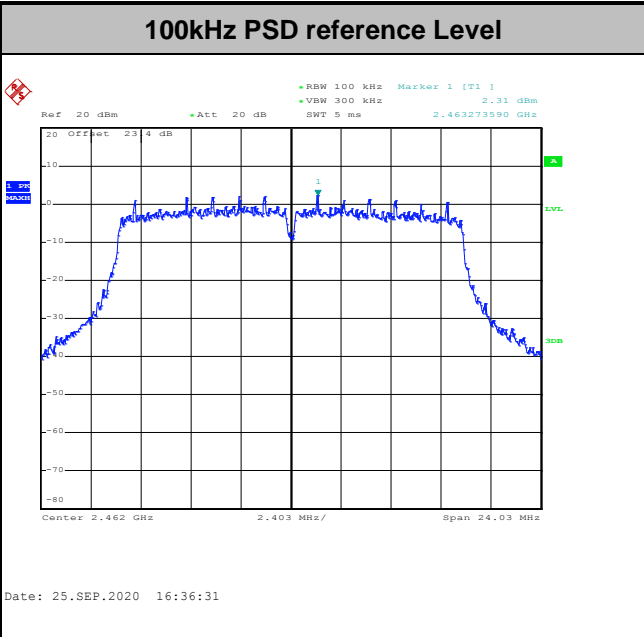



Test Mode :	802.11ax HE20	Test Channel :	01 Full RU
-------------	---------------	----------------	------------

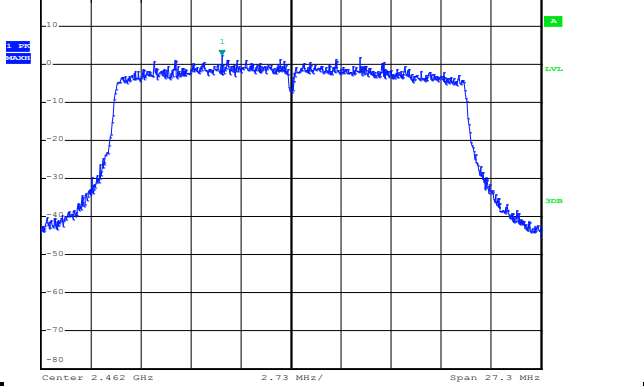
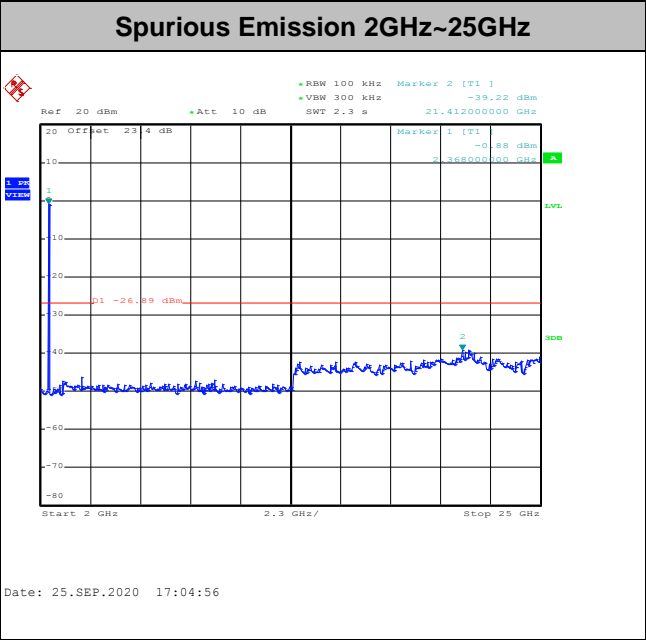
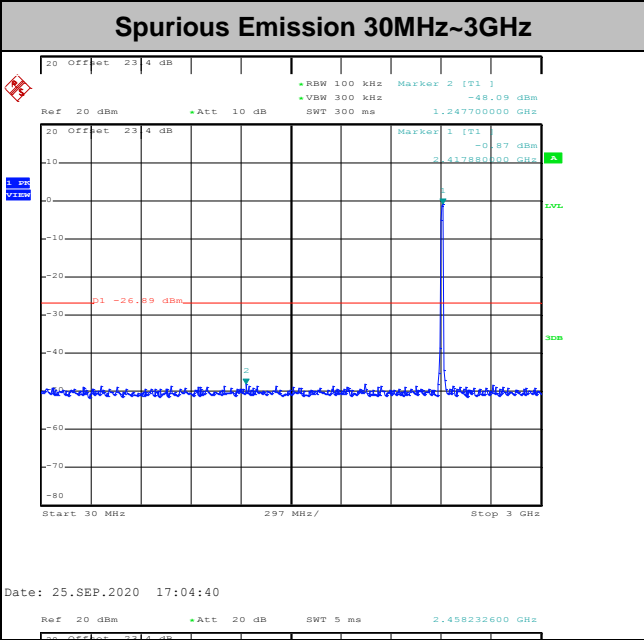
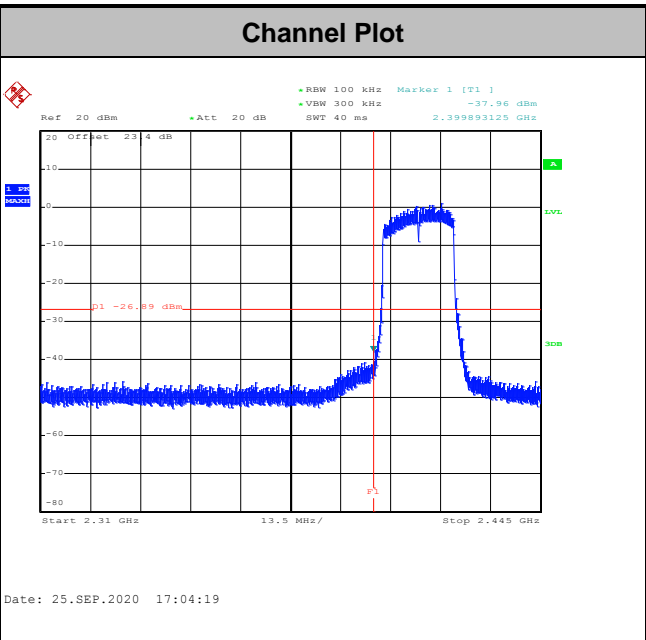
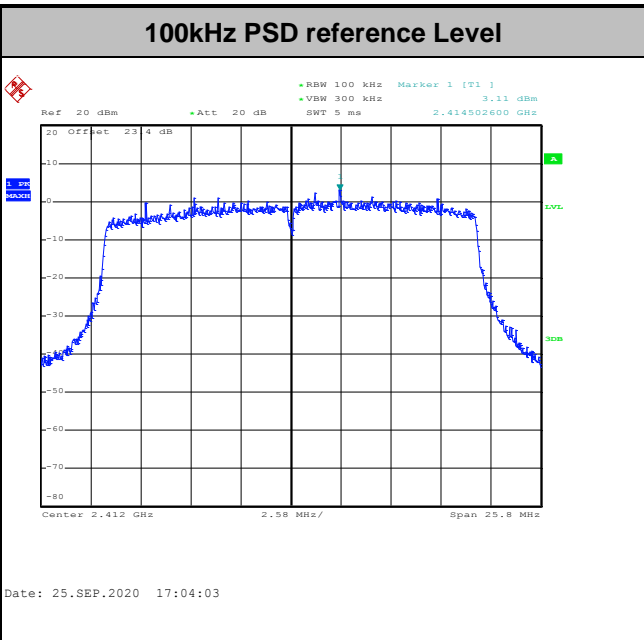





Test Mode :	802.11ax HE20	Test Channel :	06 Full RU
-------------	---------------	----------------	------------

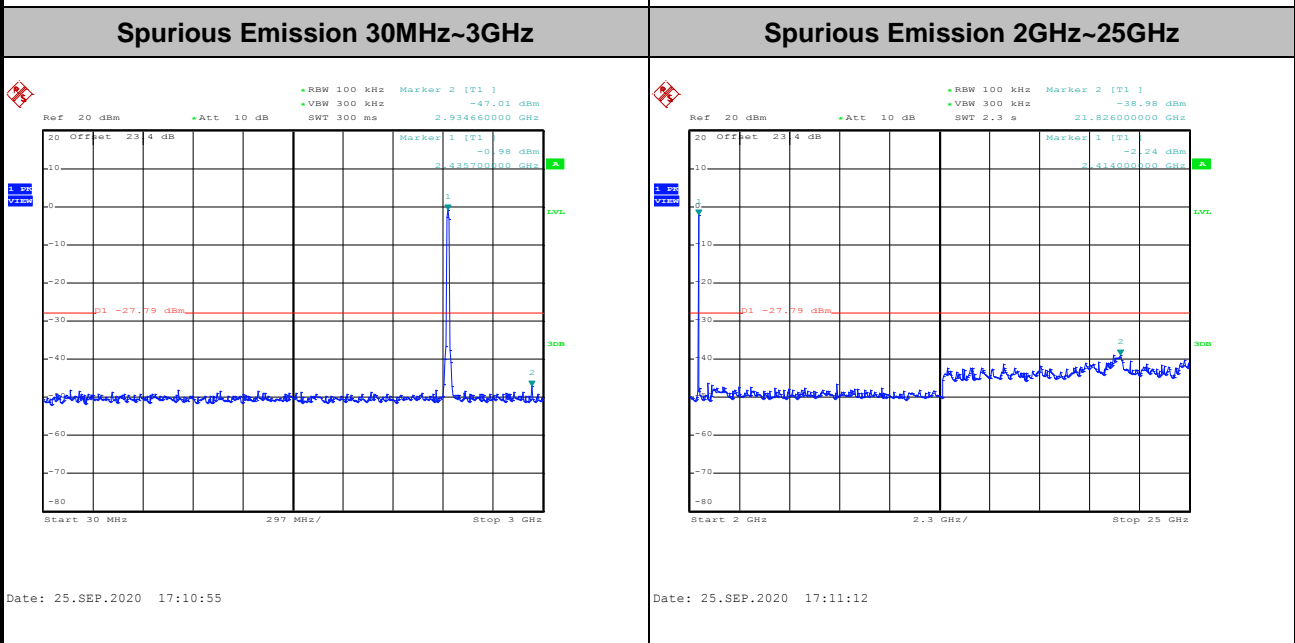
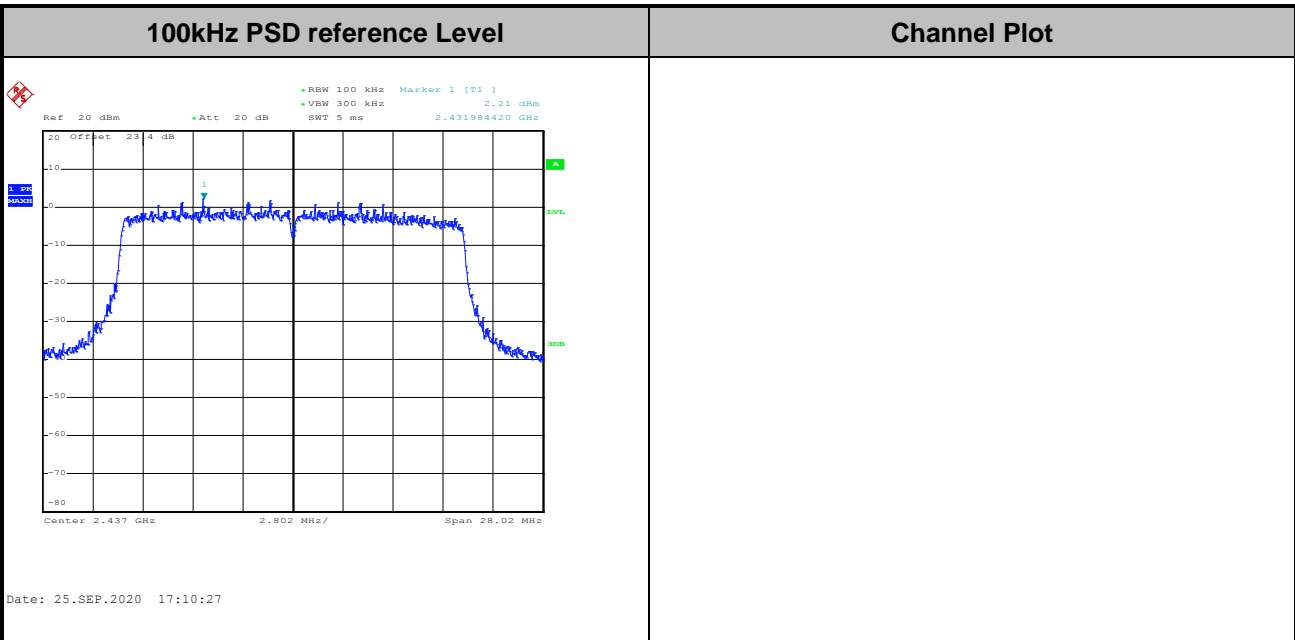



Test Mode :	802.11ax HE20	Test Channel :	11 Full RU
-------------	---------------	----------------	------------

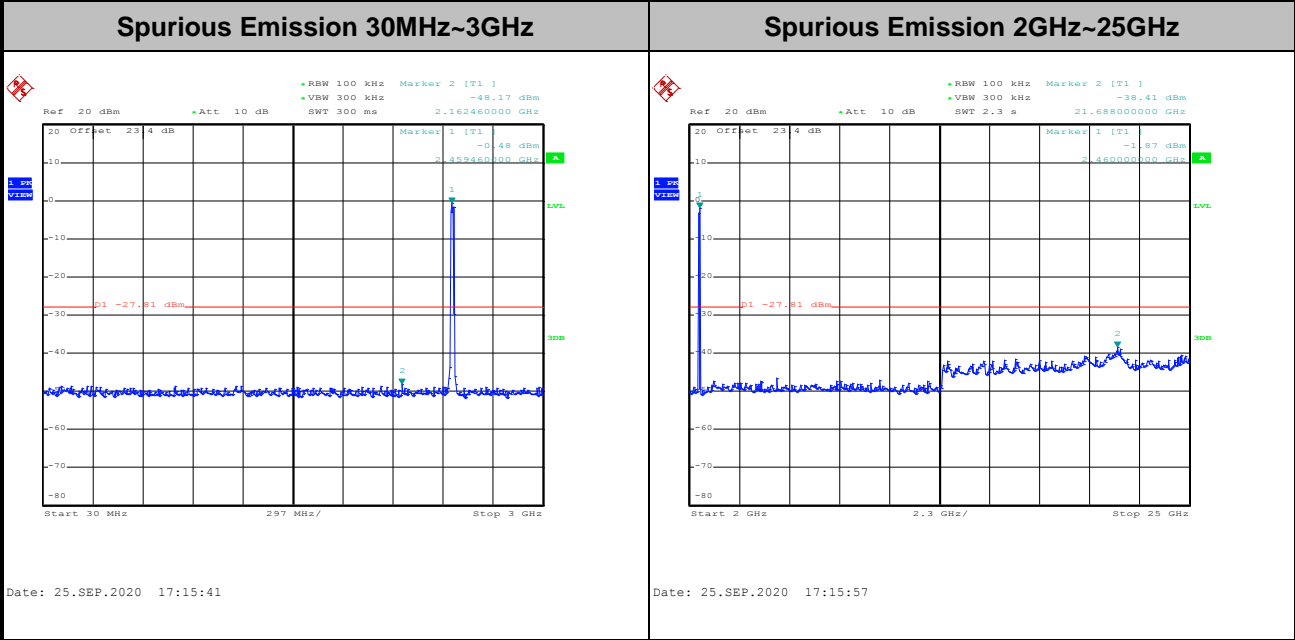
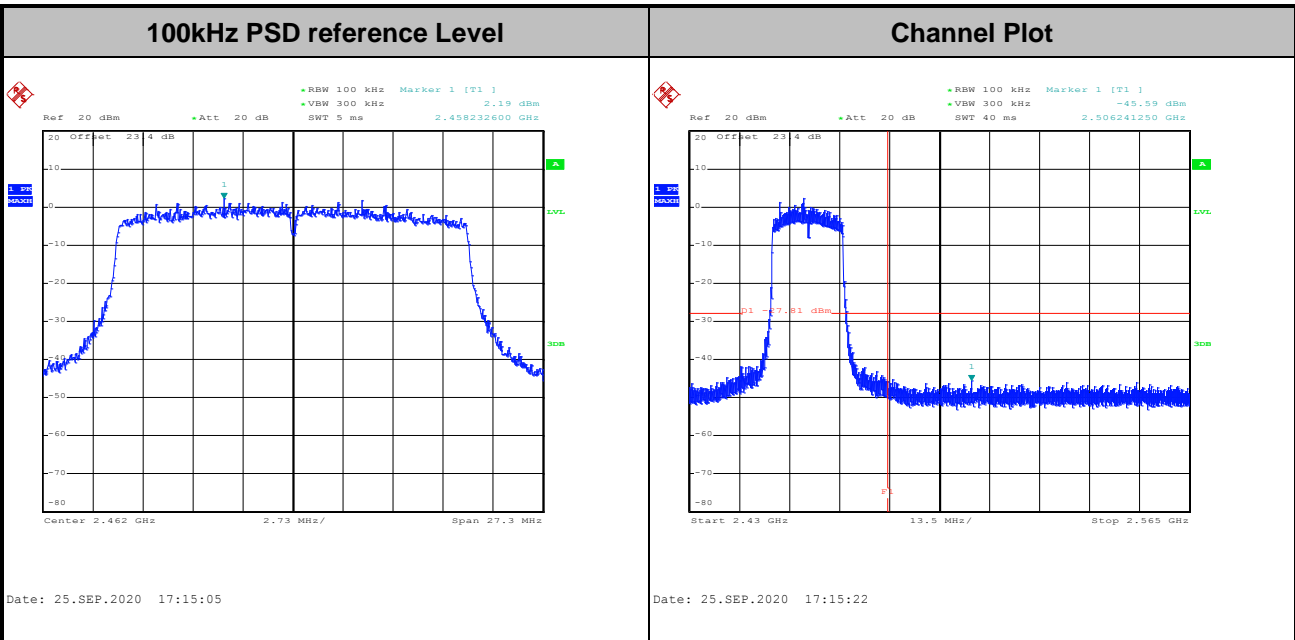



Test Mode :	802.11ax HE40	Test Channel :	03 Full RU
-------------	---------------	----------------	------------

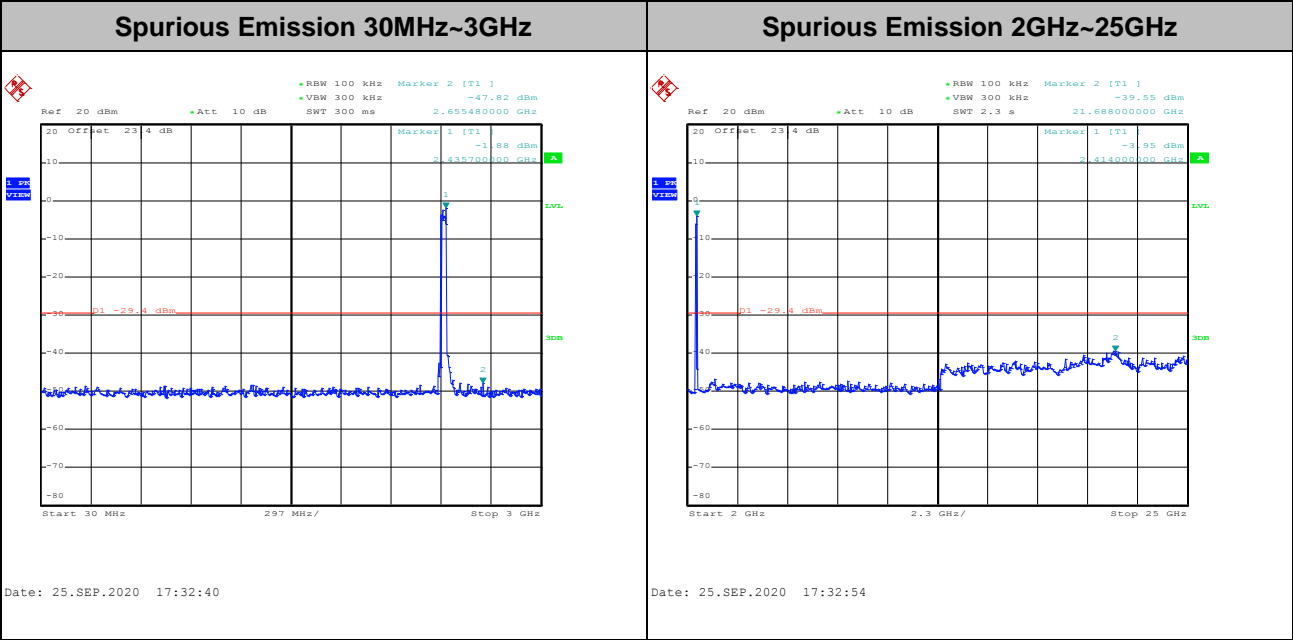
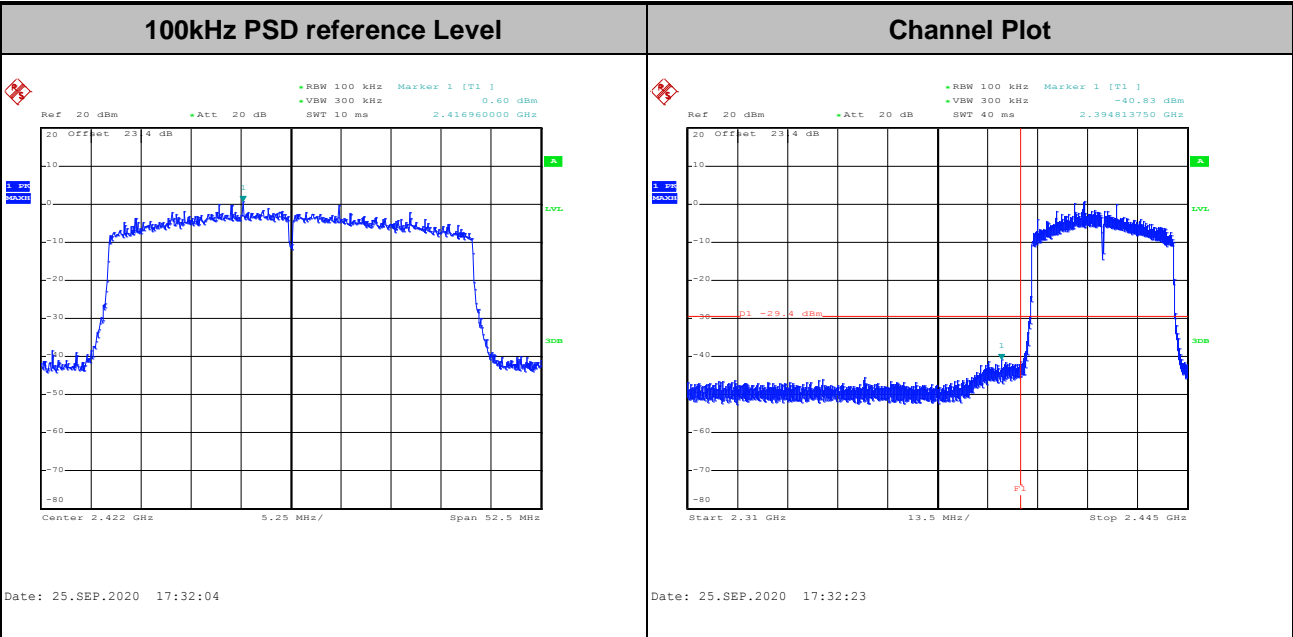



Test Mode :	802.11ax HE40	Test Channel :	06 Full RU
-------------	---------------	----------------	------------

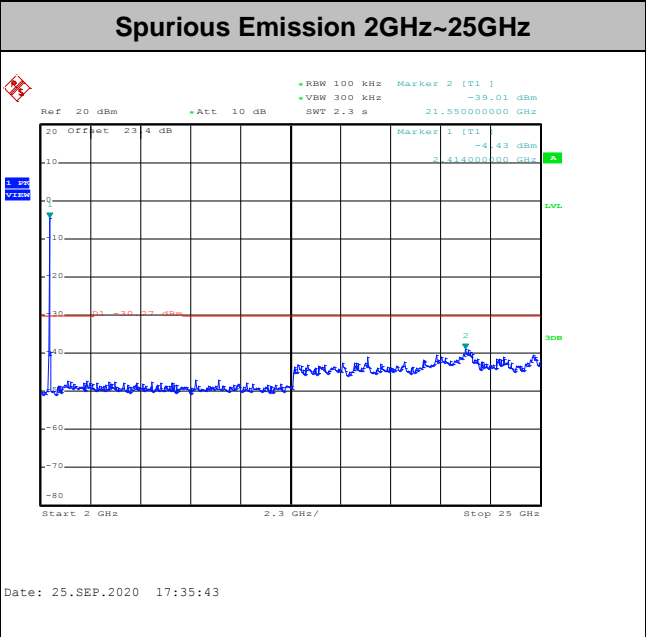
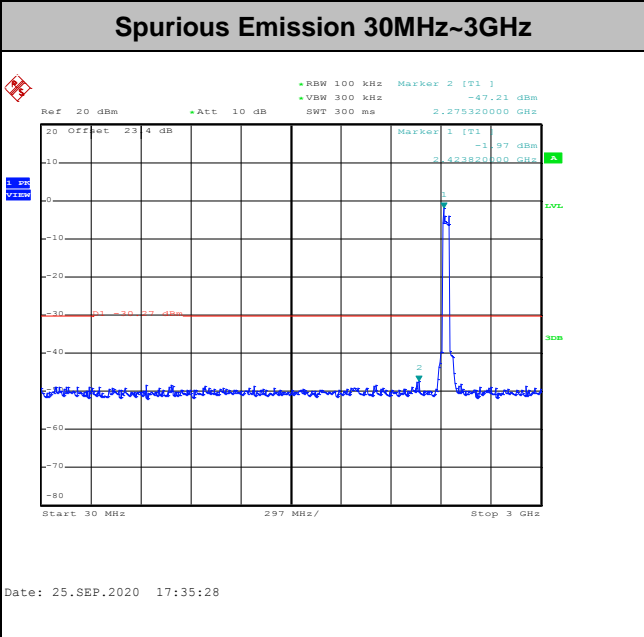
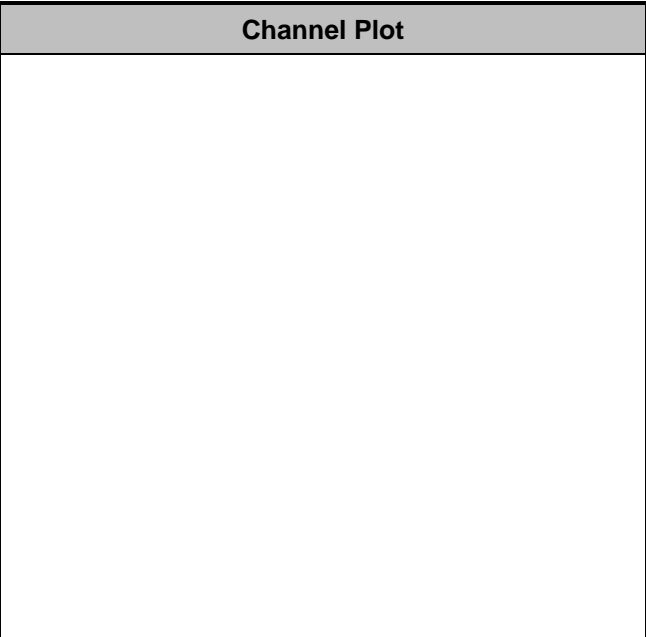
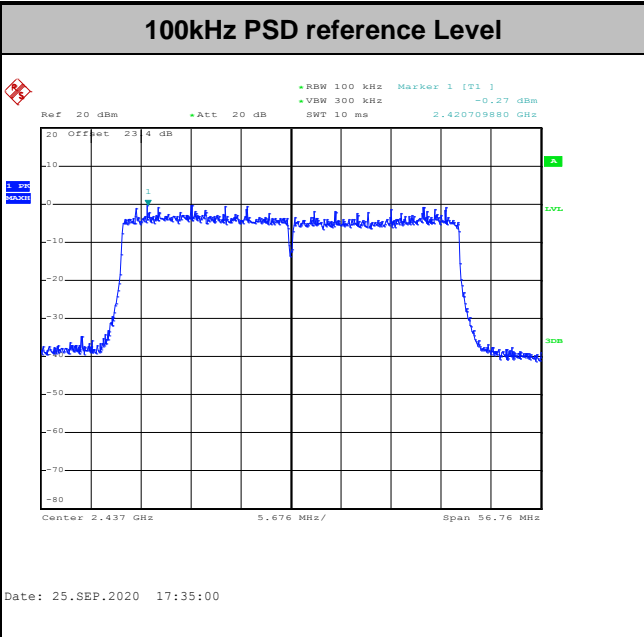



Test Mode :	802.11ax HE40	Test Channel :	09 Full RU
-------------	---------------	----------------	------------

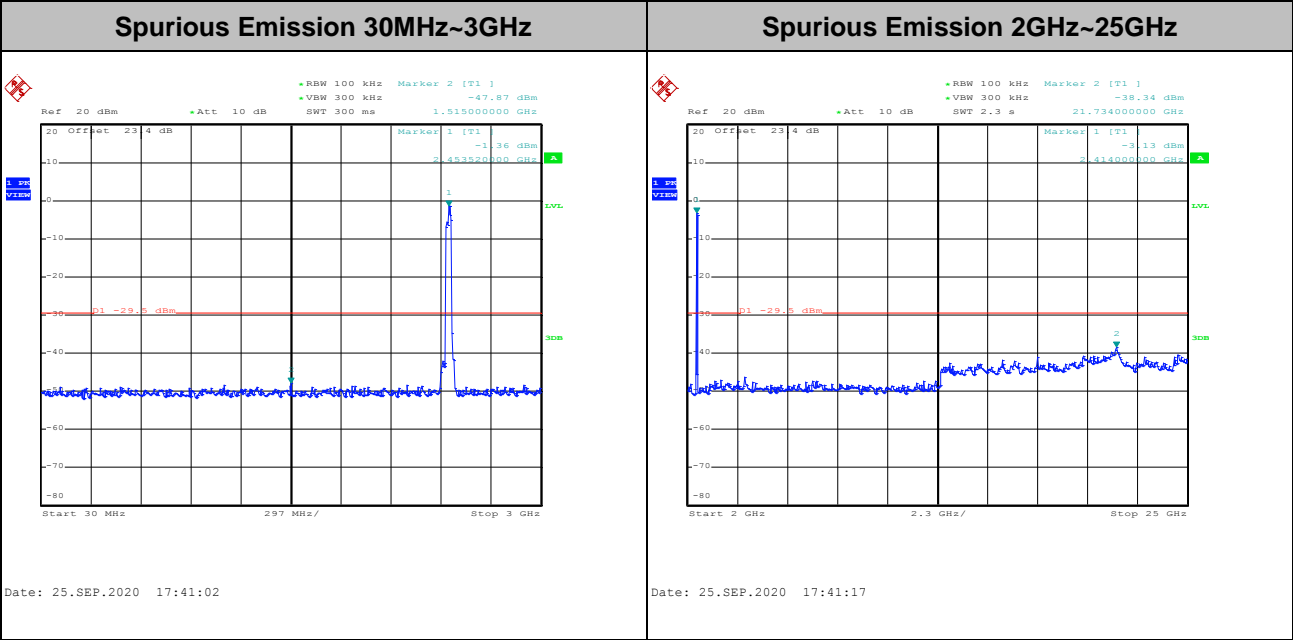
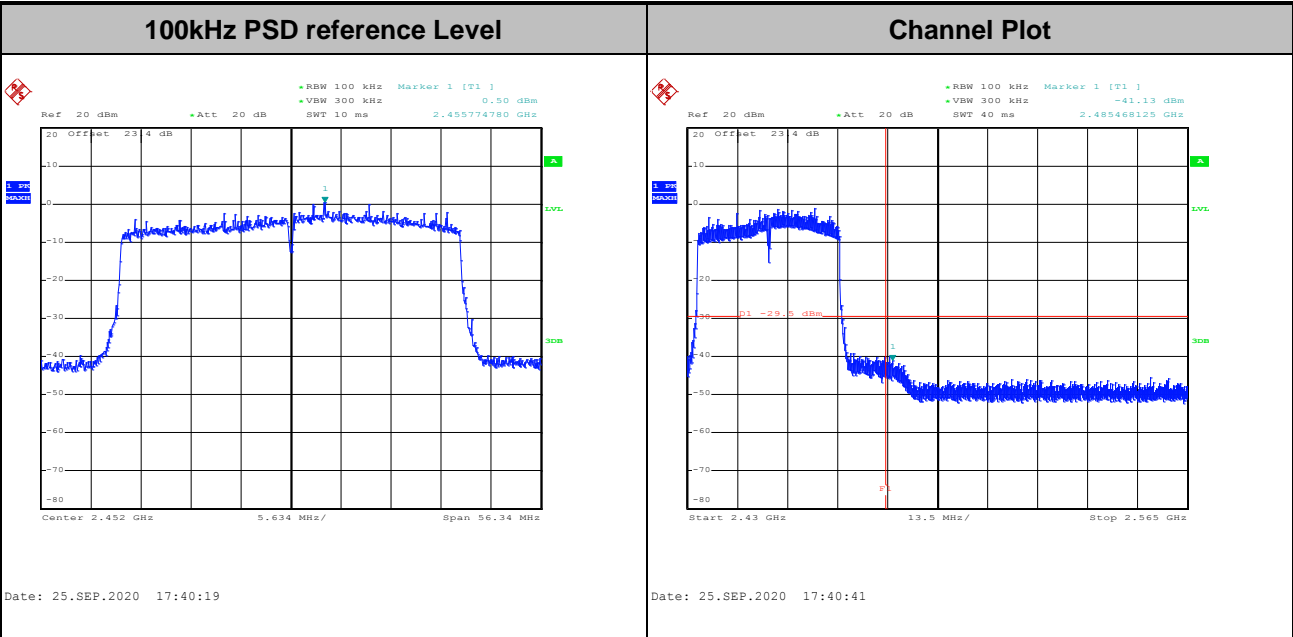



Number of TX = 2, Ant. 1 (Measured)

Test Mode :	802.11b	Test Channel :	01
-------------	---------	----------------	----

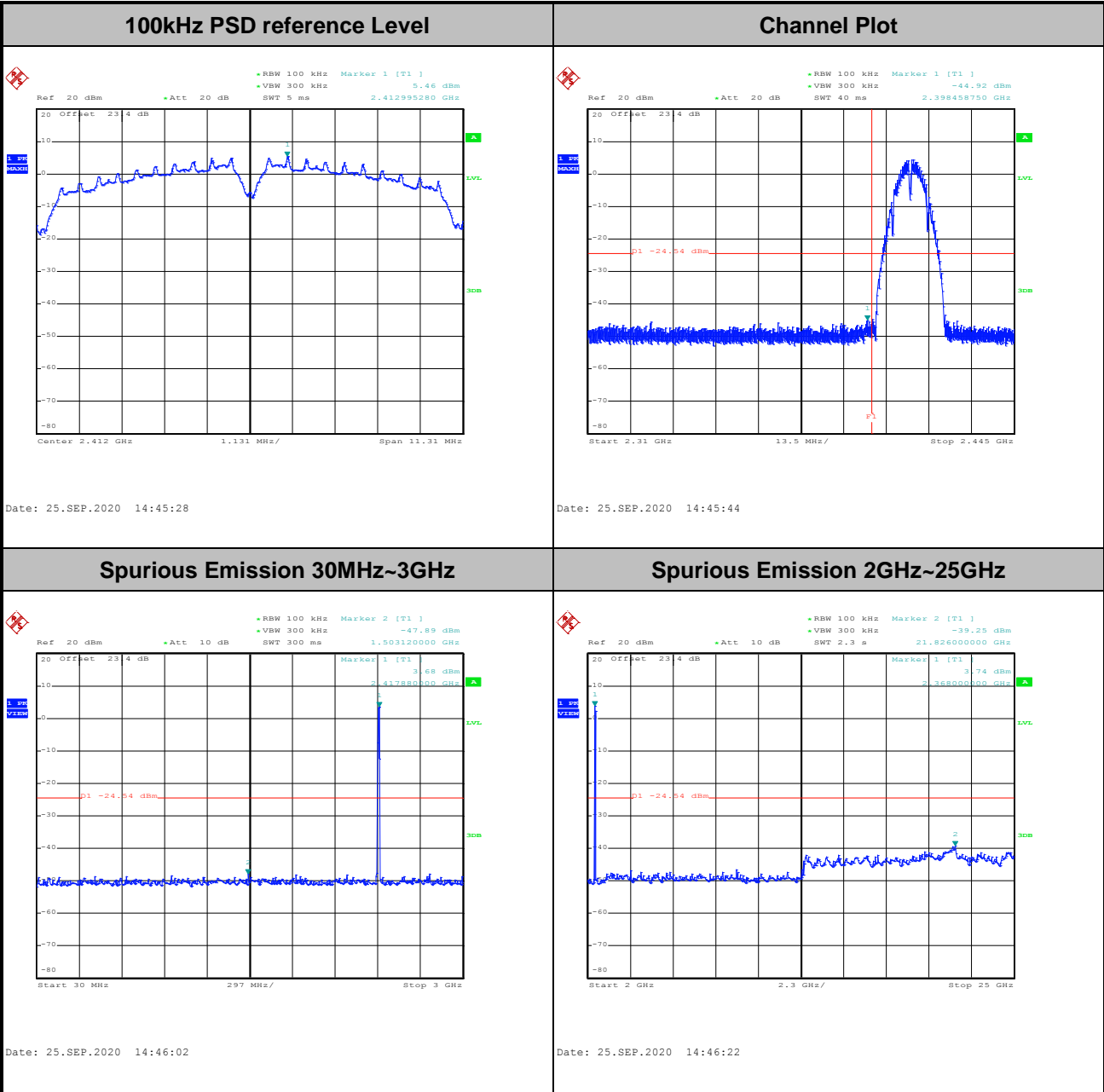



Test Mode :	802.11b	Test Channel :	06
-------------	---------	----------------	----

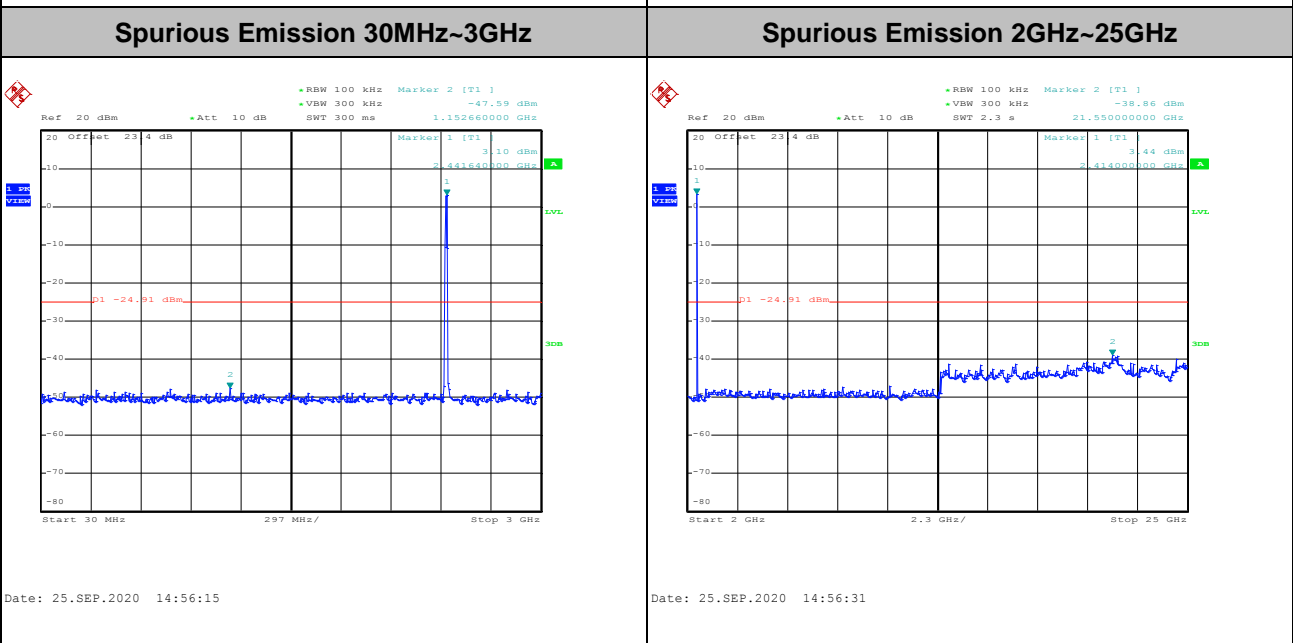
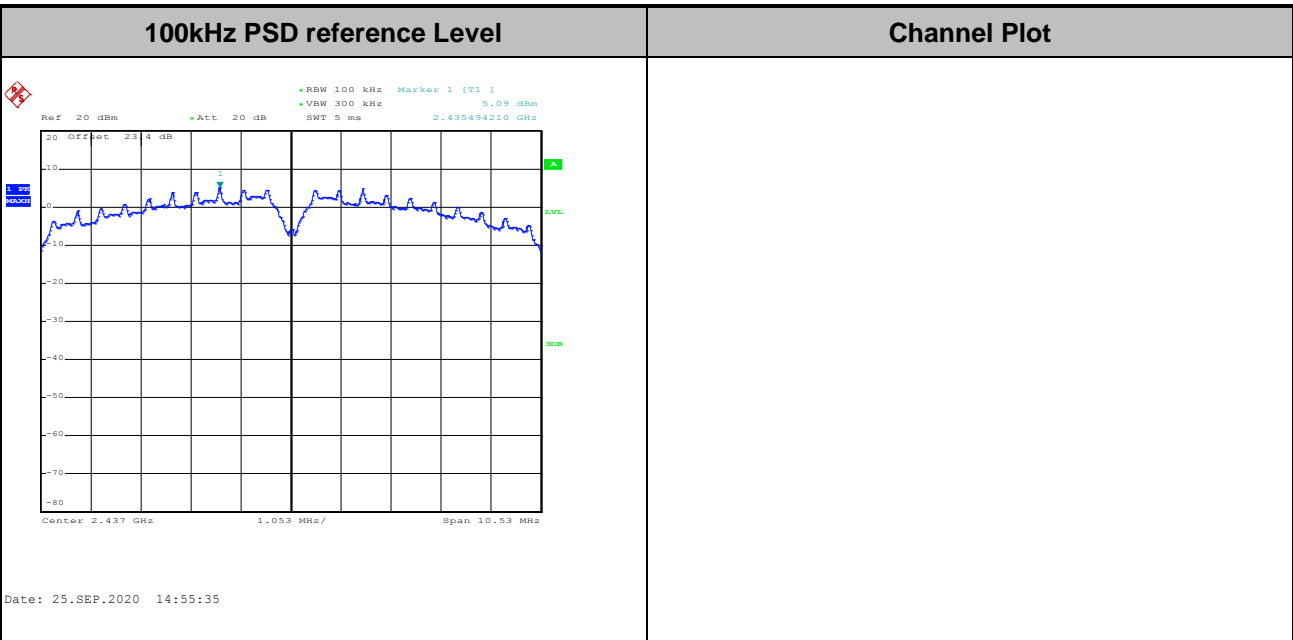



Test Mode :	802.11b	Test Channel :	11
-------------	---------	----------------	----

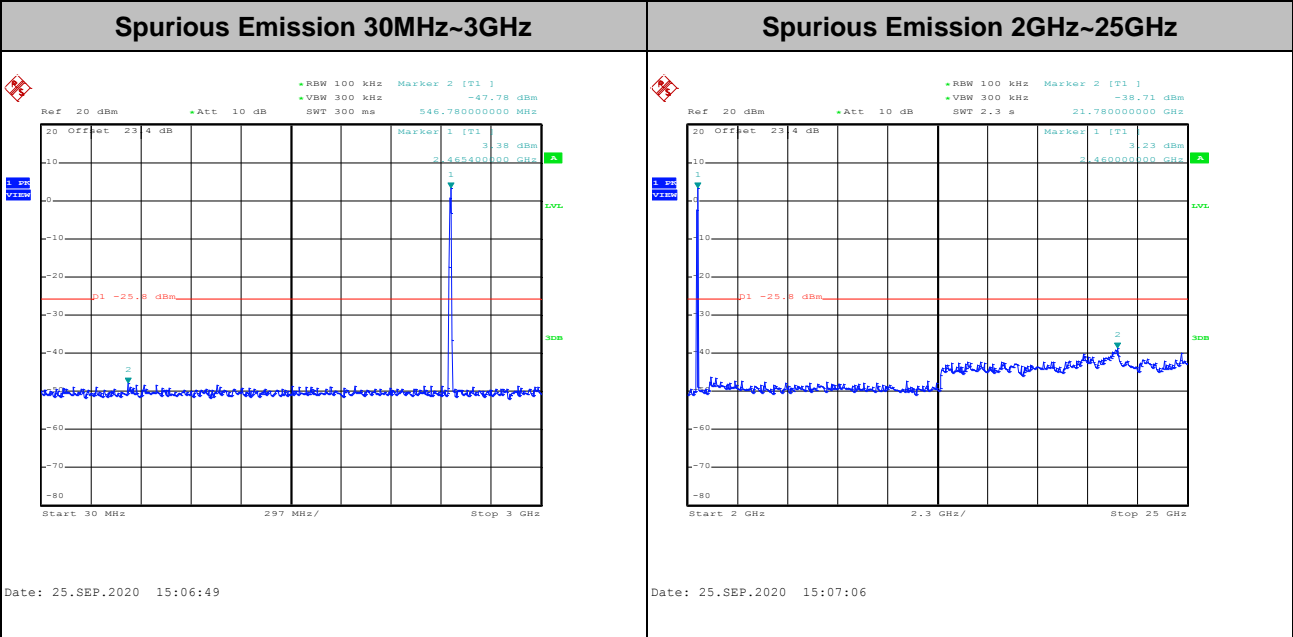
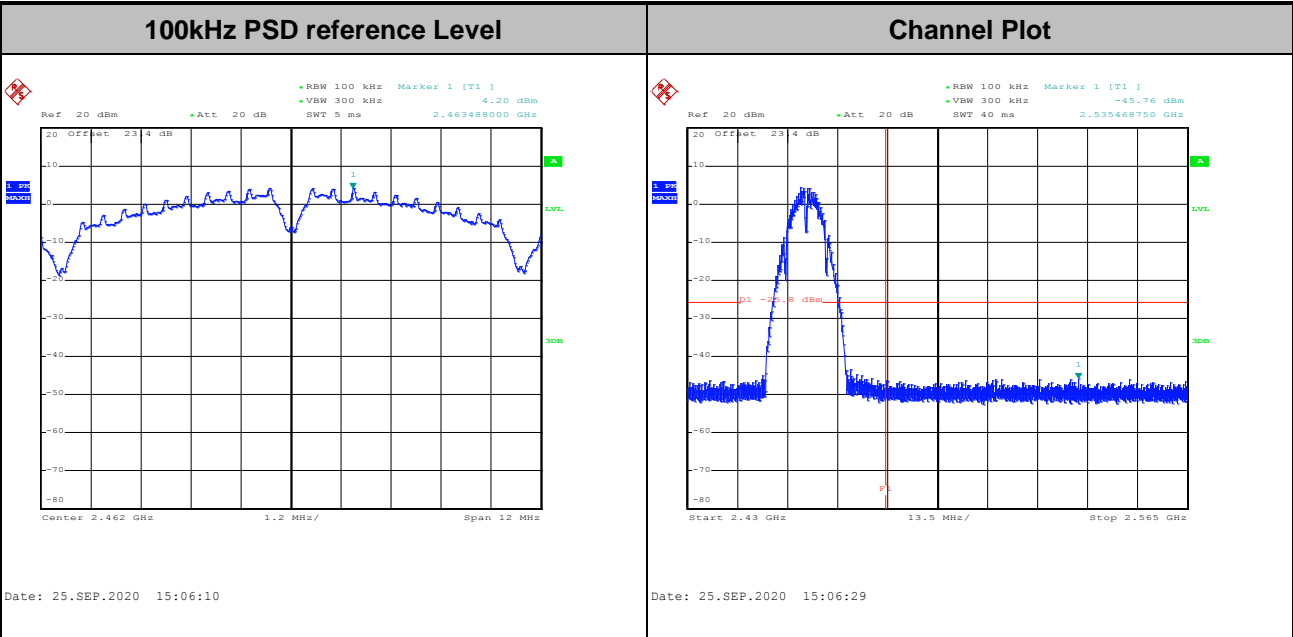





Test Mode :	802.11g	Test Channel :	01
-------------	---------	----------------	----

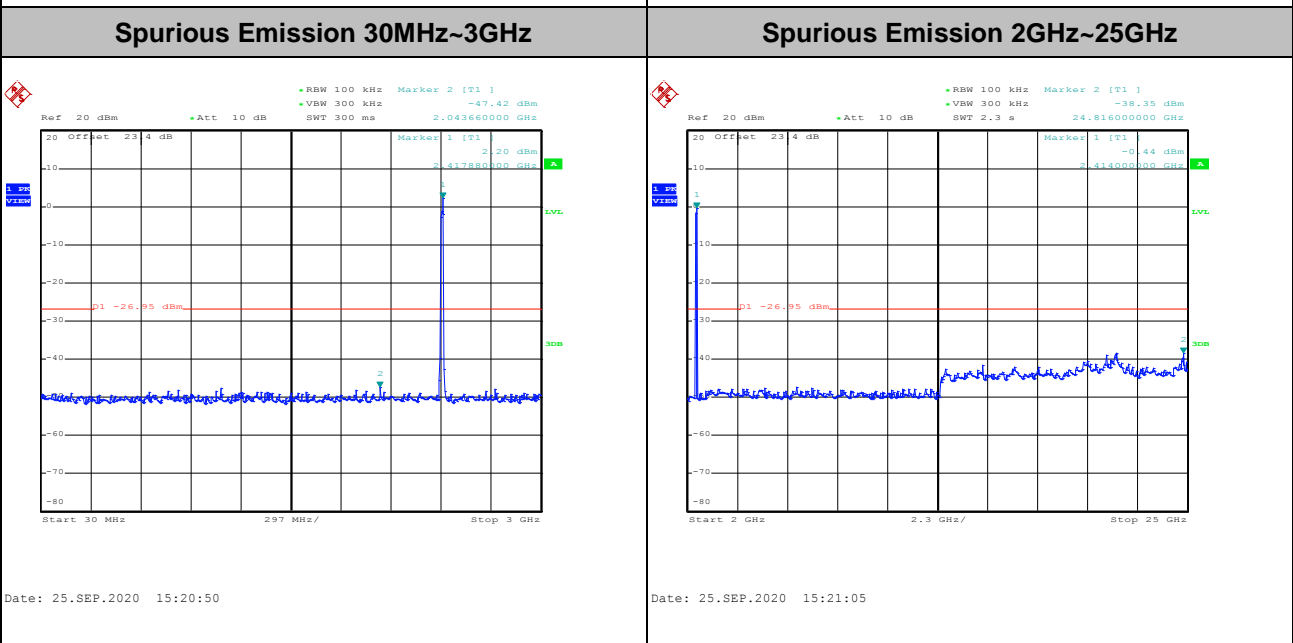
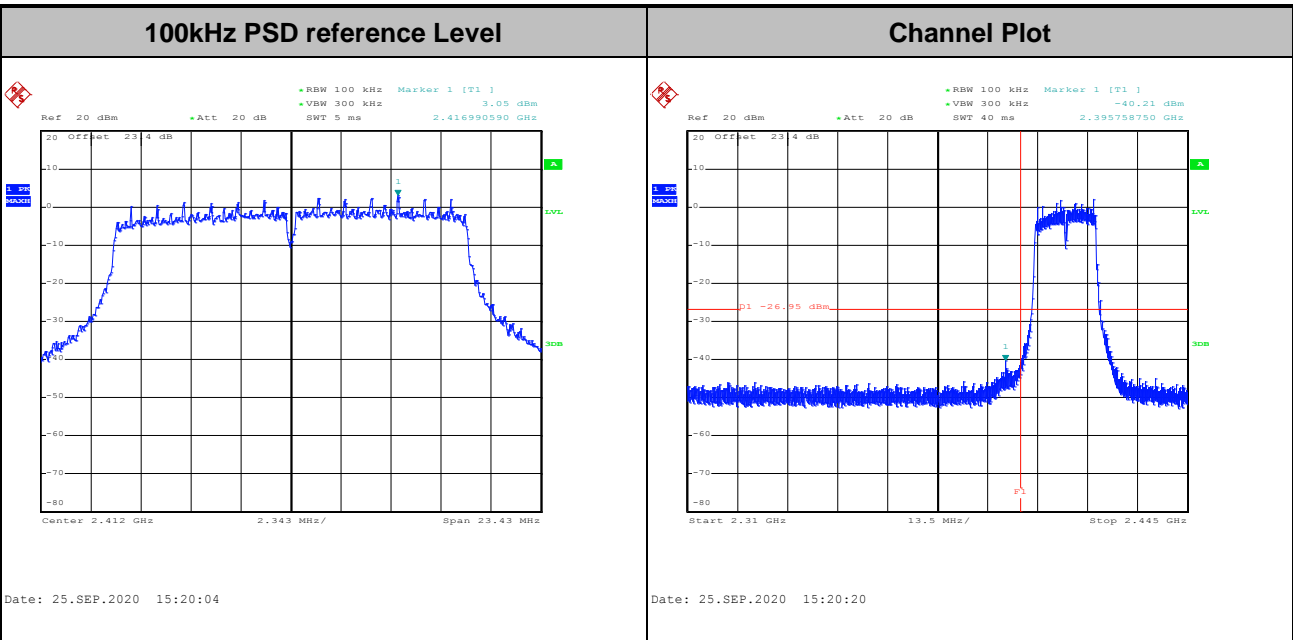



Test Mode :	802.11g	Test Channel :	06
-------------	---------	----------------	----

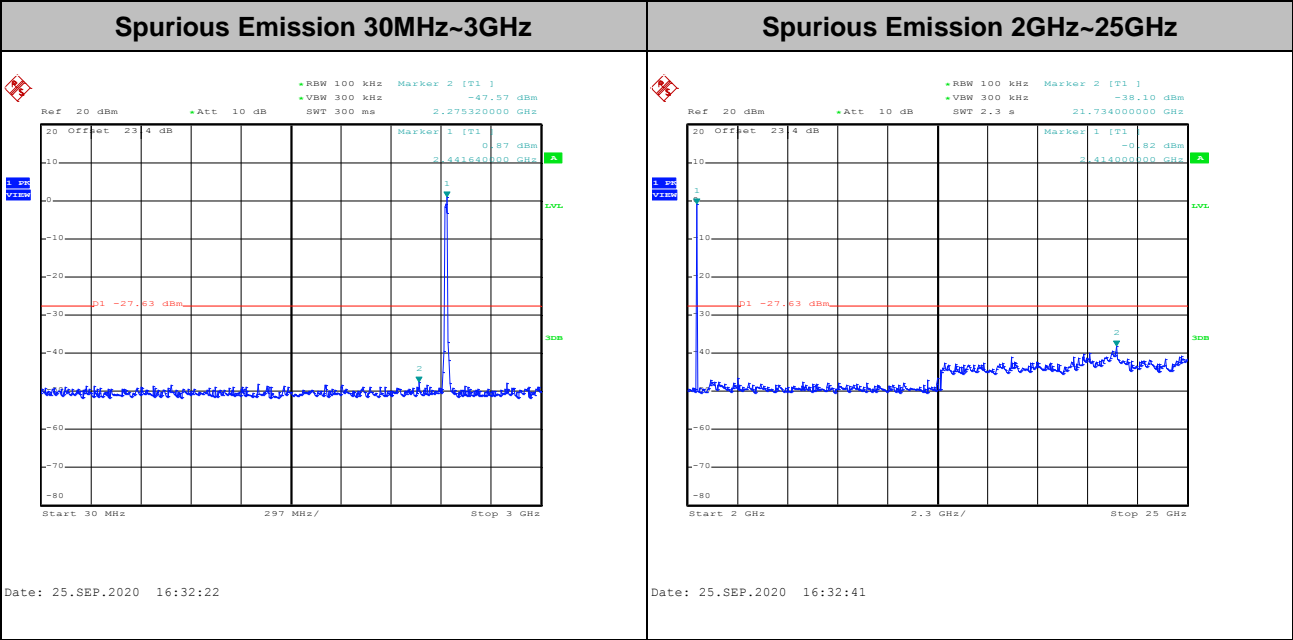
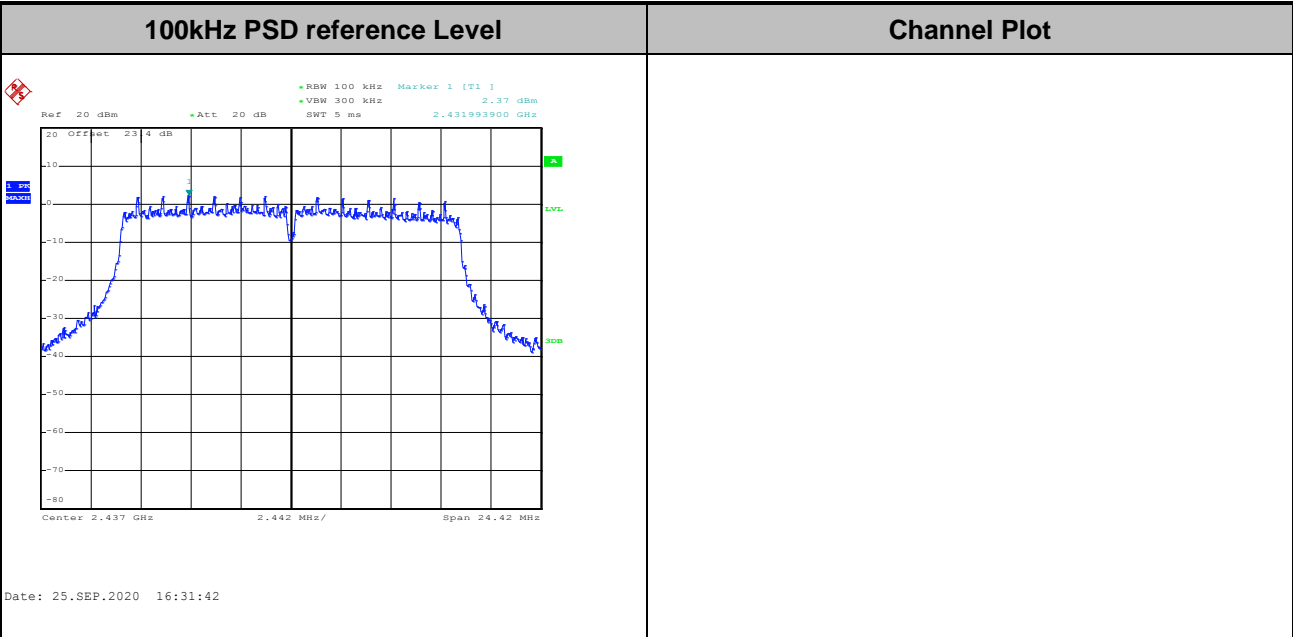



Test Mode : 802.11g Test Channel : 11

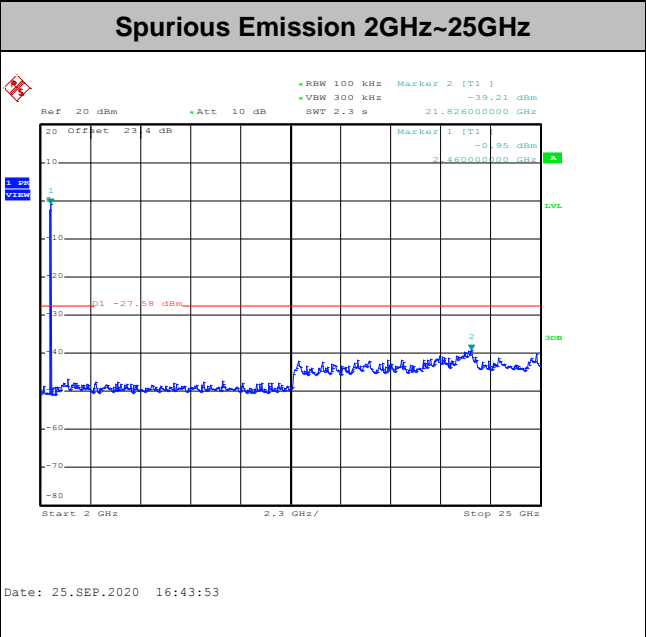
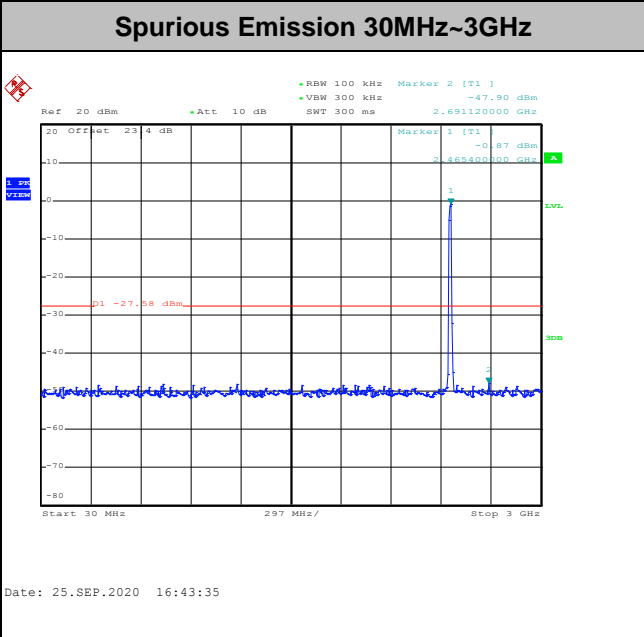
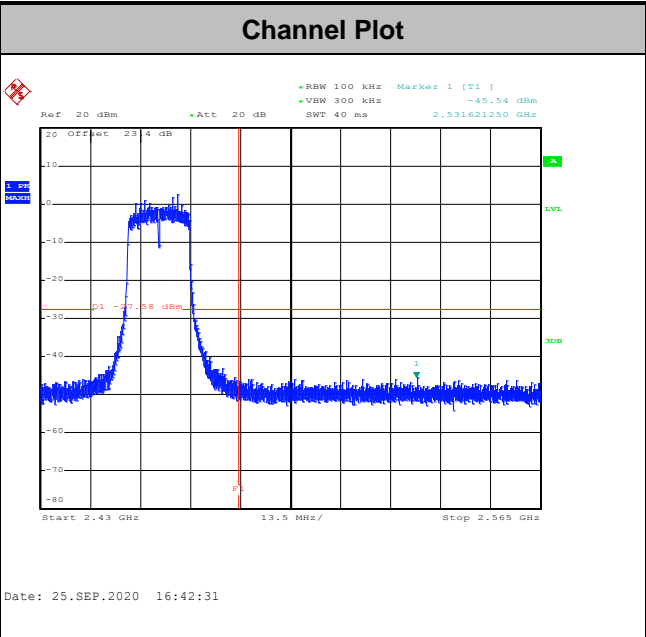
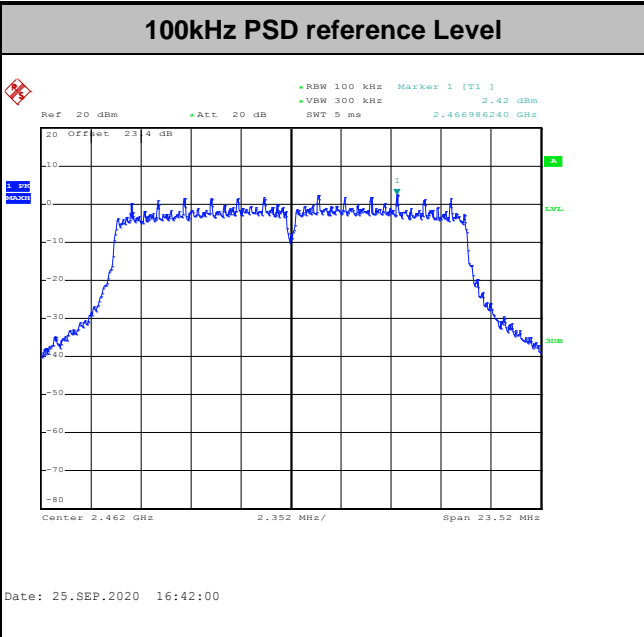



Test Mode :	802.11ax HE20	Test Channel :	01 Full RU
-------------	---------------	----------------	------------

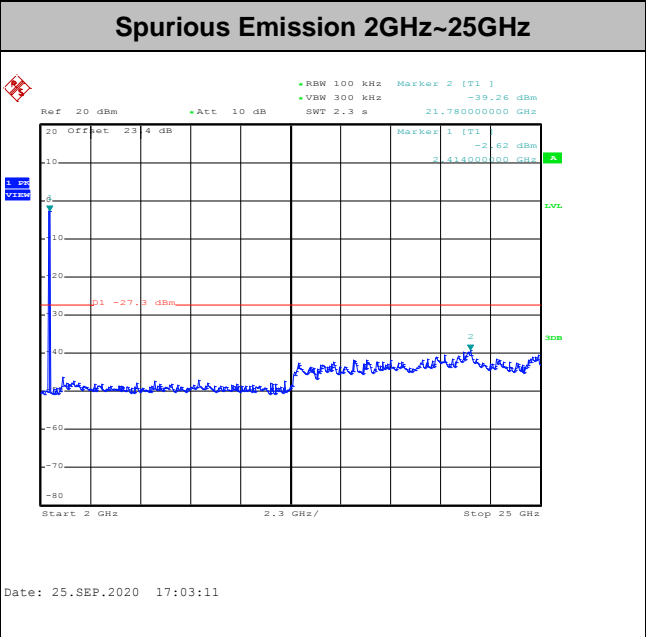
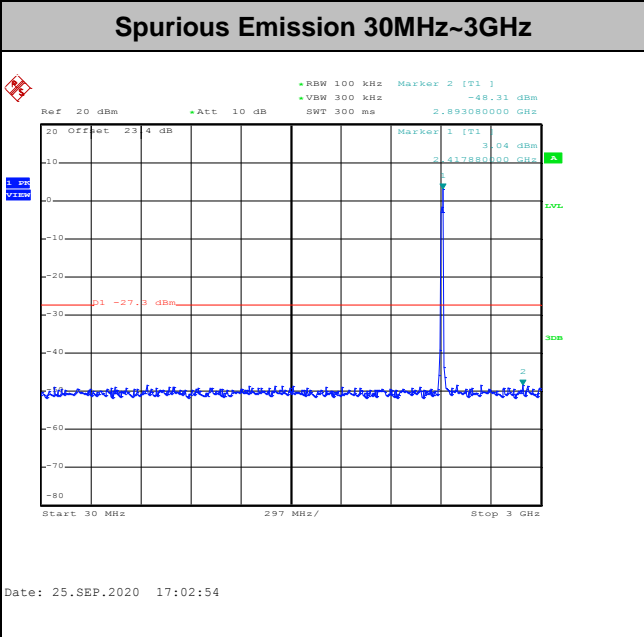
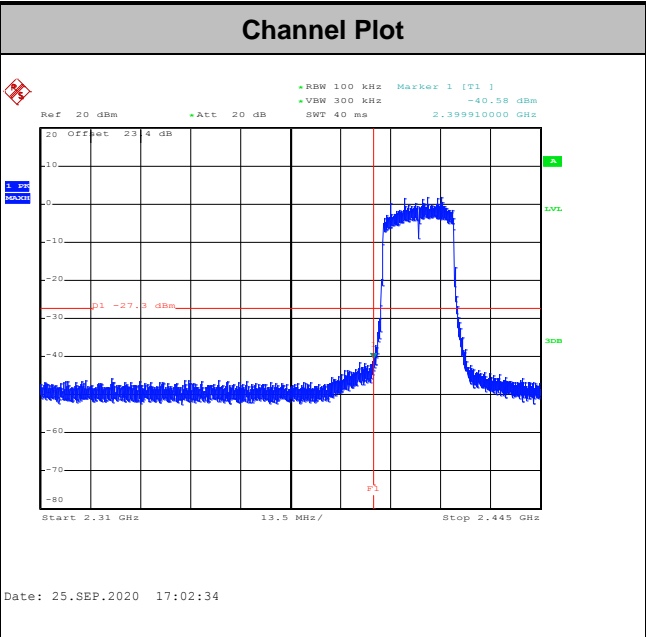
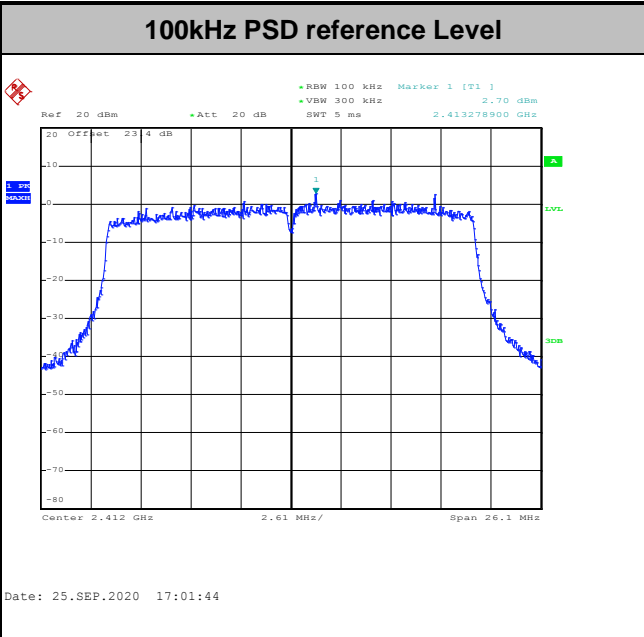



Test Mode :	802.11ax HE20	Test Channel :	06 Full RU
-------------	---------------	----------------	------------

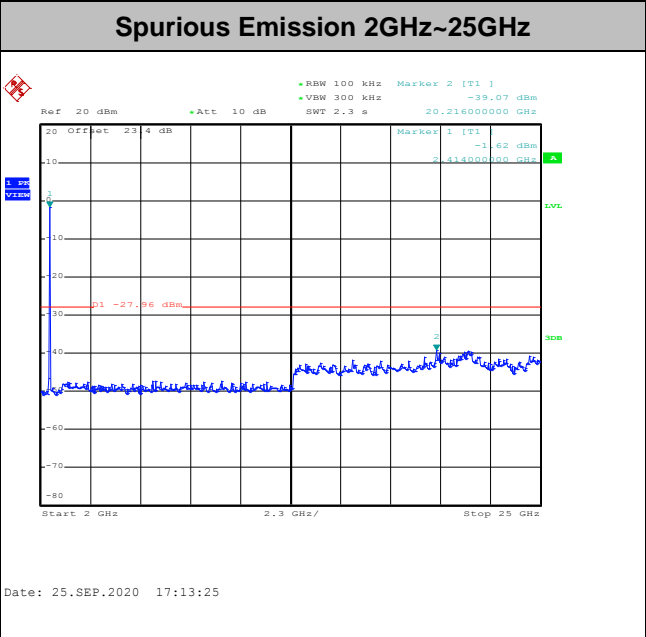
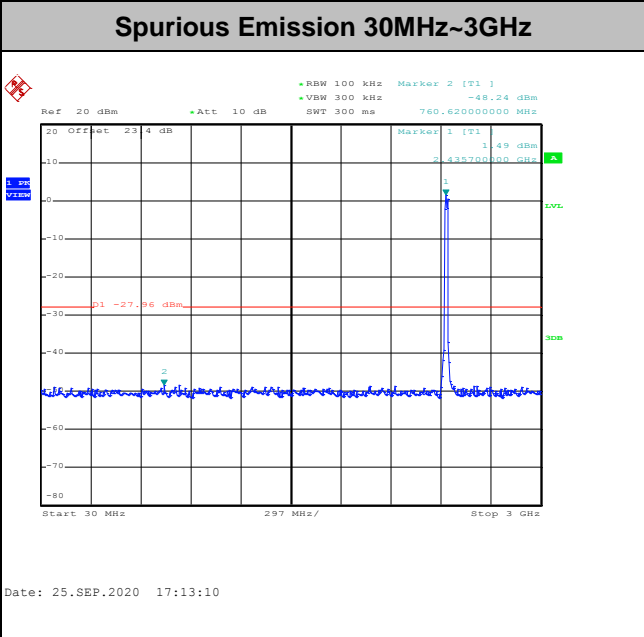
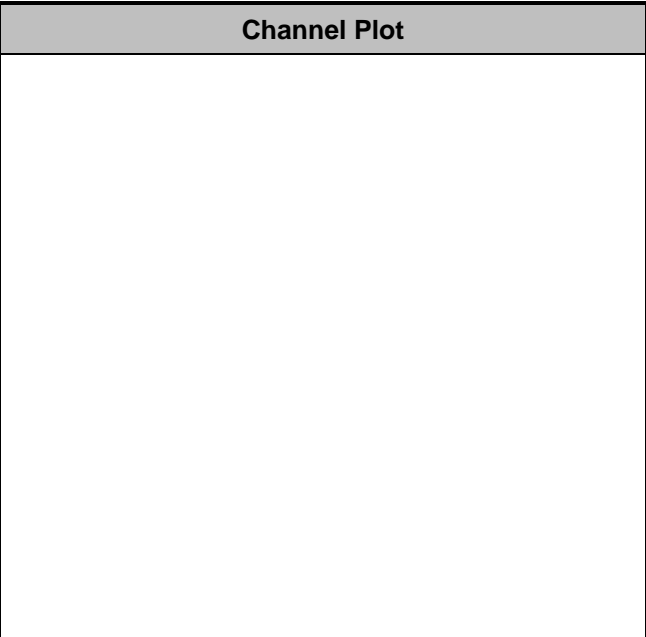
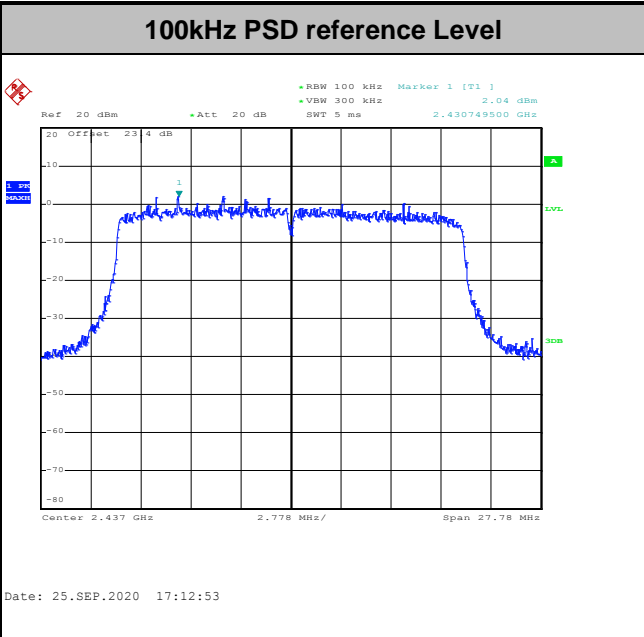



Test Mode :	802.11ax HE20	Test Channel :	11 Full RU
-------------	---------------	----------------	------------

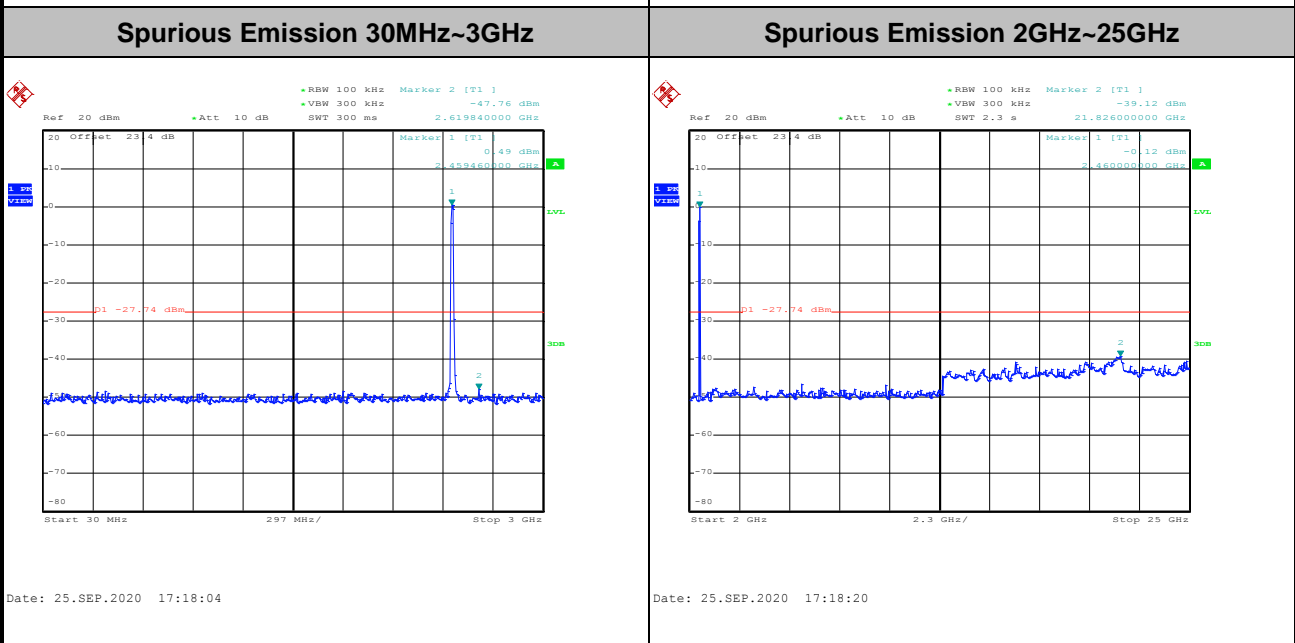
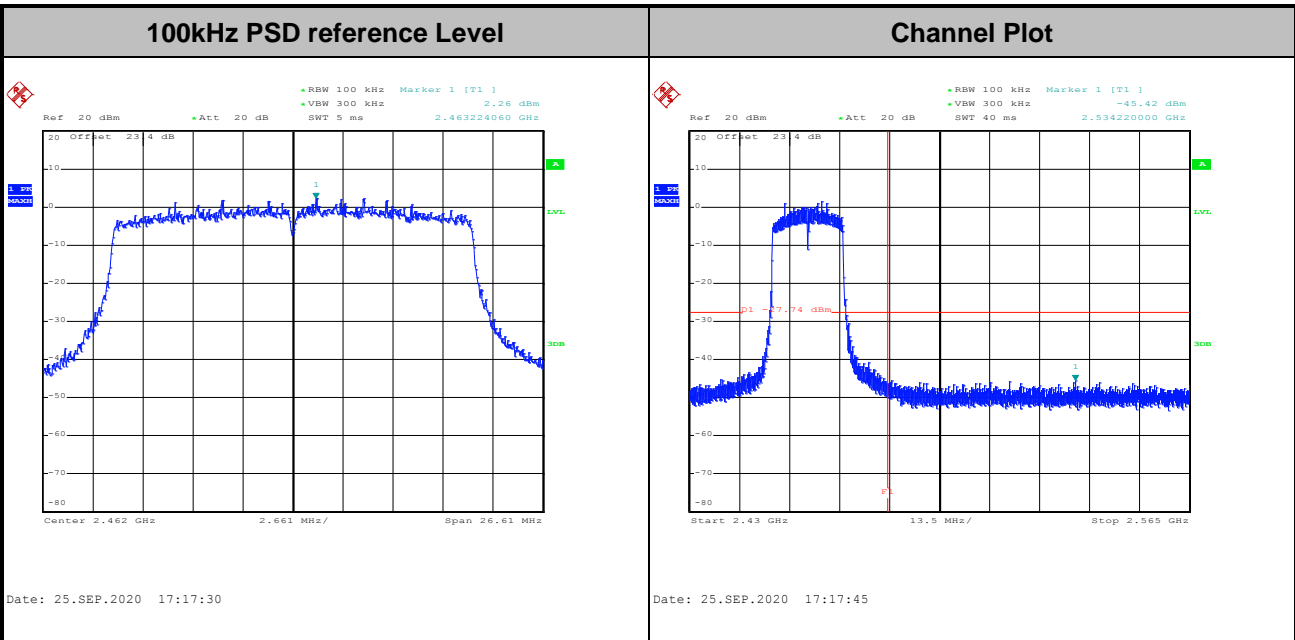



Test Mode :	802.11ax HE40	Test Channel :	03 Full RU
-------------	---------------	----------------	------------

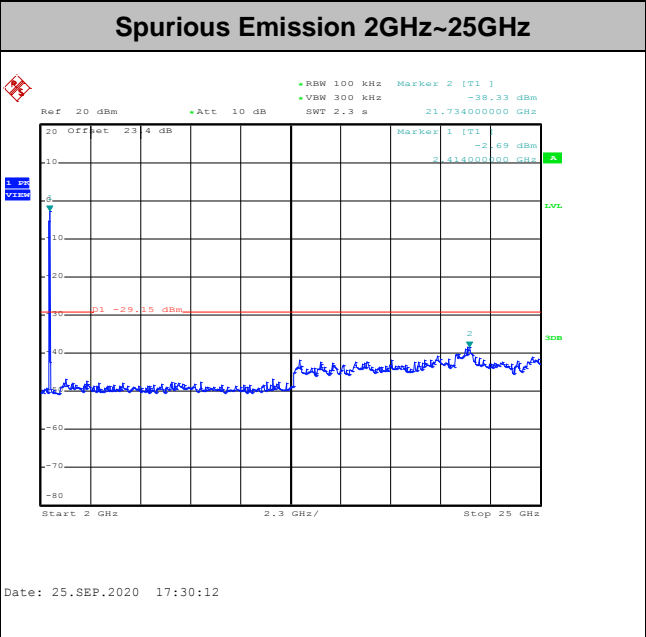
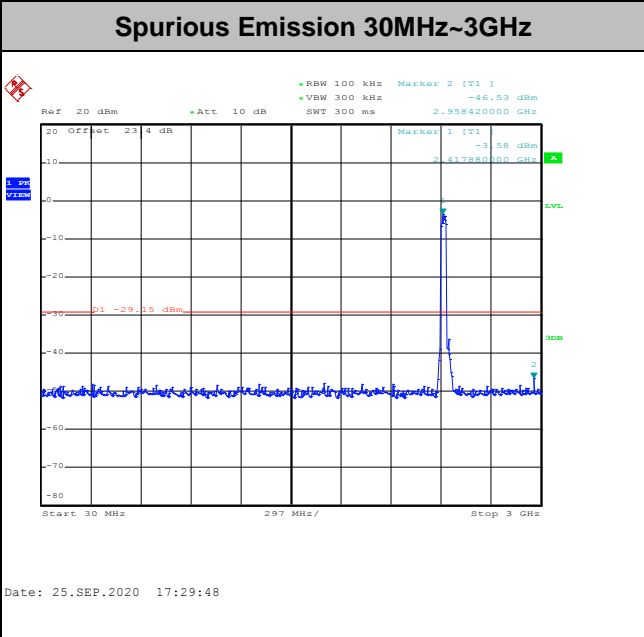
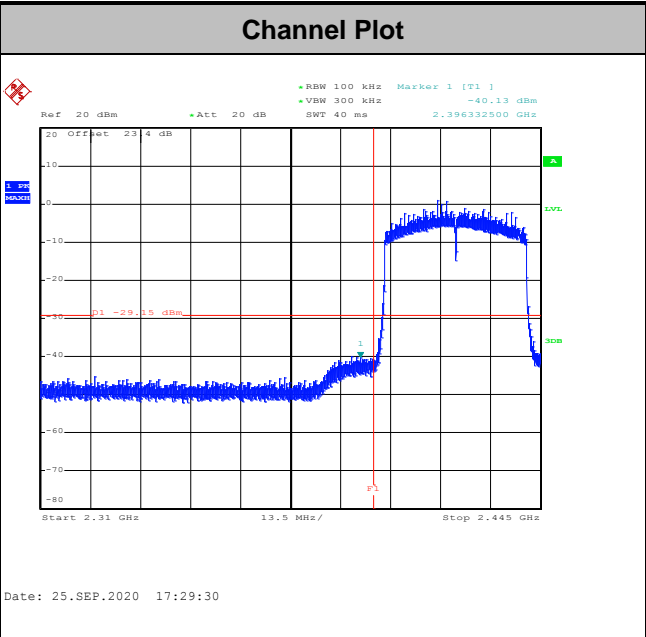
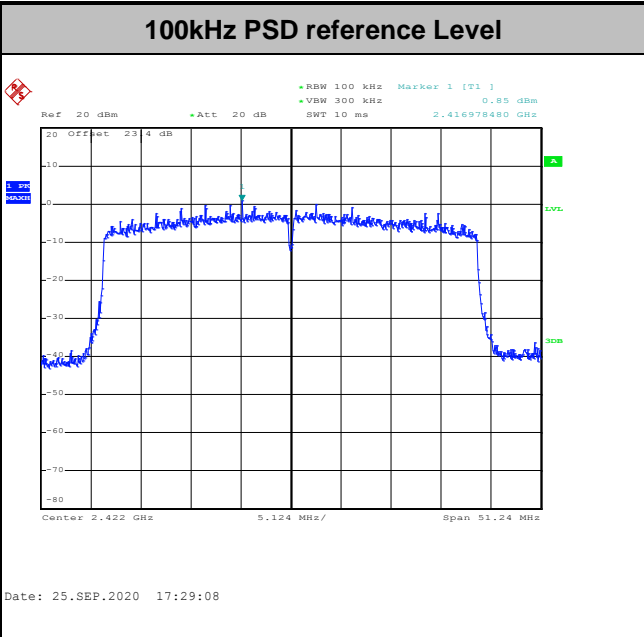



Test Mode :	802.11ax HE40	Test Channel :	06 Full RU
-------------	---------------	----------------	------------

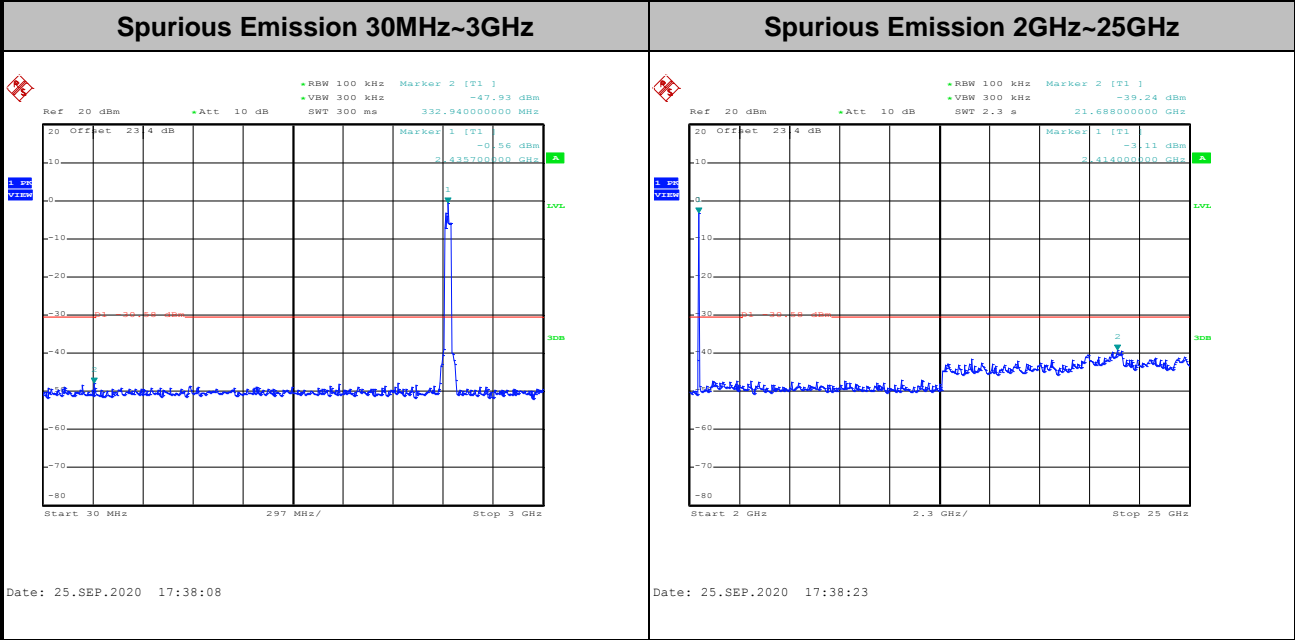
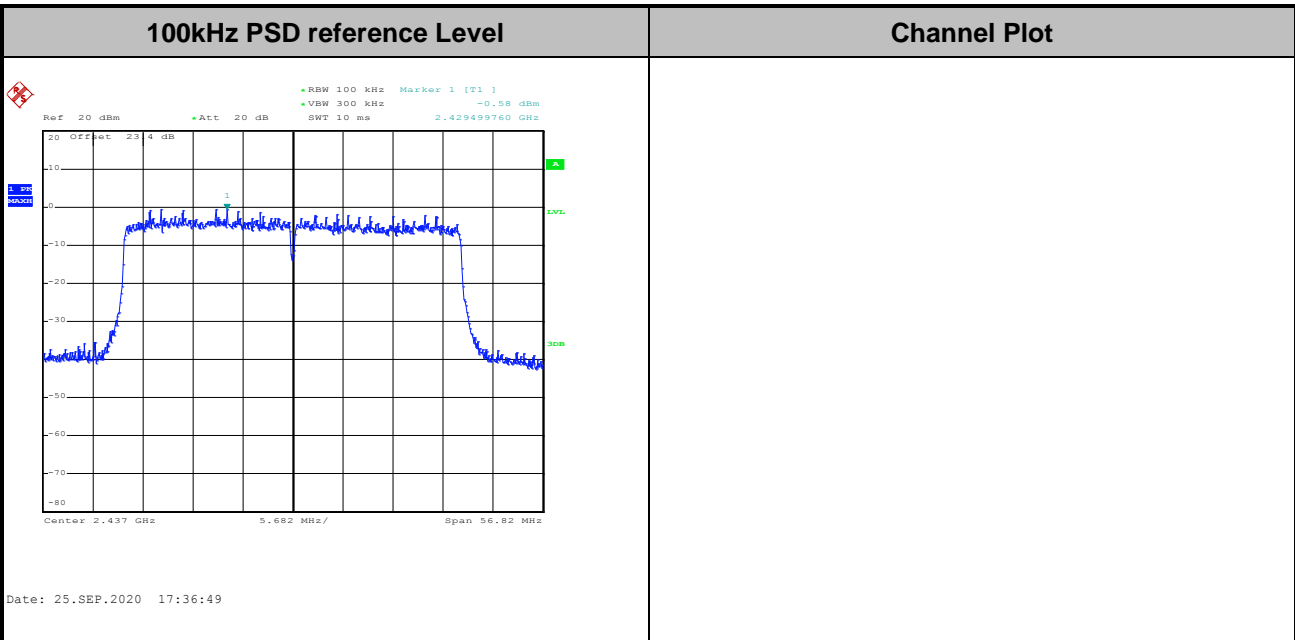





Test Mode :	802.11ax HE40	Test Channel :	09 Full RU
-------------	---------------	----------------	------------

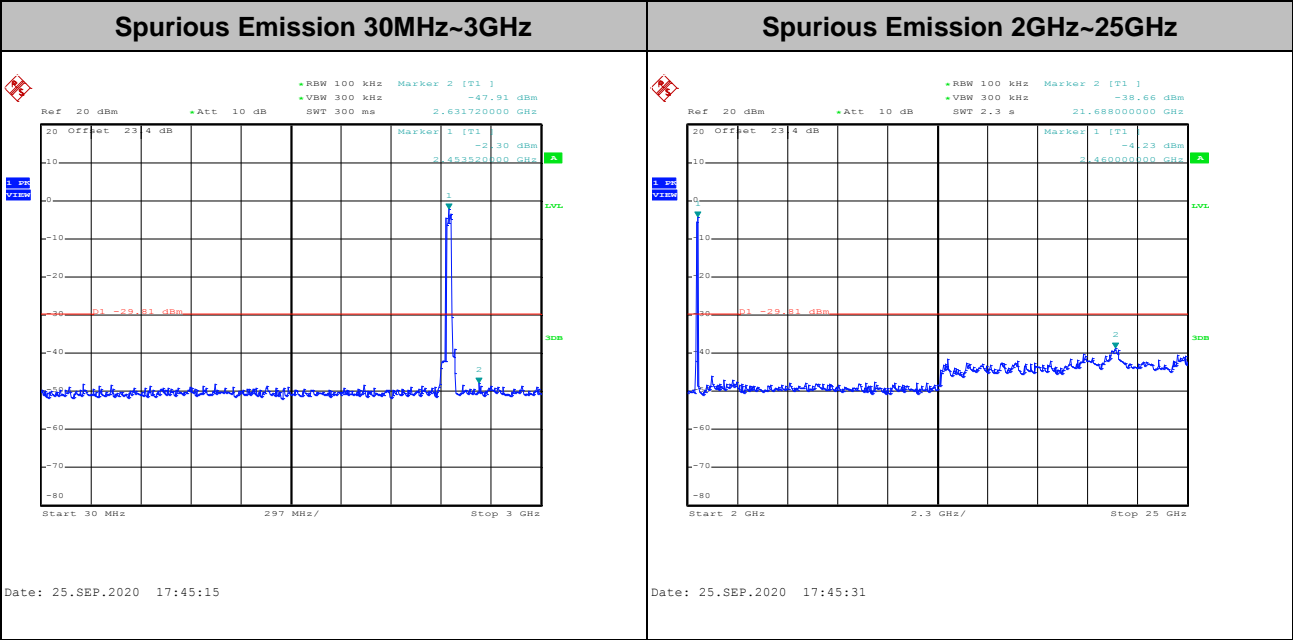
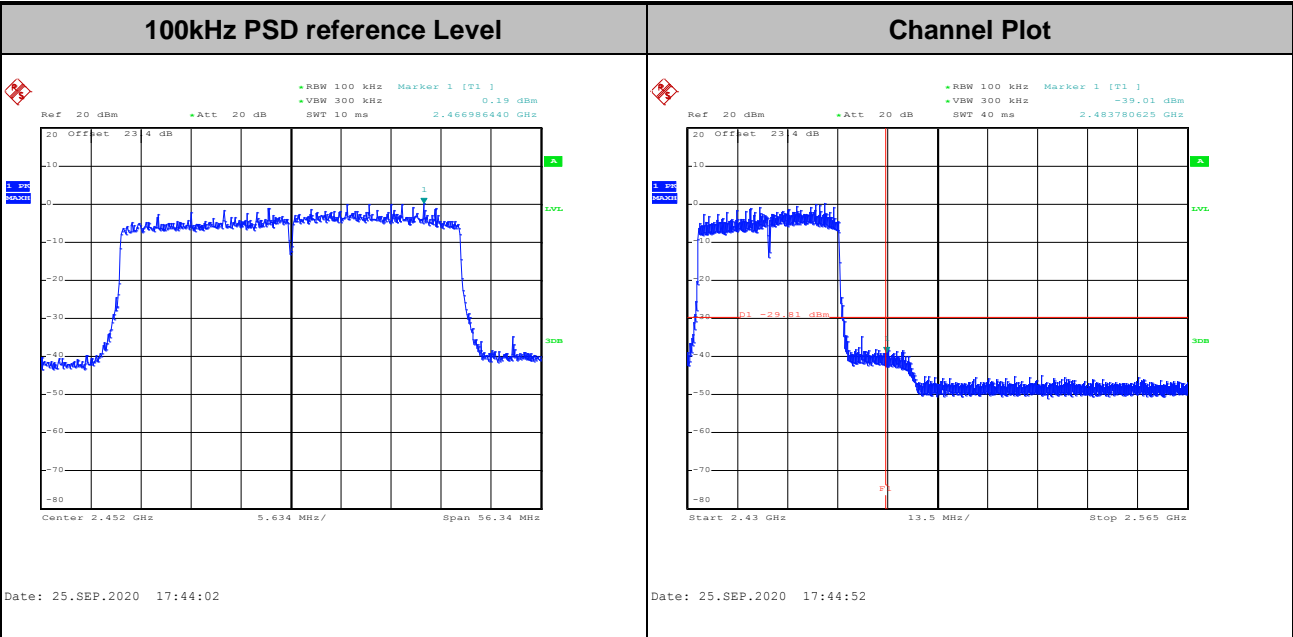



### 3.5 Radiated Band Edges and Spurious Emission Measurement

#### 3.5.1 Limit of Radiated band edge and Spurious Emission Measurement

In any 100 kHz bandwidth outside the intentional radiator frequency band, all harmonics/spurious must be at least 20 dB below the highest emission level within the authorized band. If the output power of this device was measured by spectrum analyzer, the attenuation under this paragraph shall be 30 dB instead of 20 dB. In addition, radiated emissions which fall in the restricted bands must also comply with the limits as below.

Frequency (MHz)	Field Strength (microvolts/meter)	Measurement Distance (meters)
0.009 – 0.490	2400/F(kHz)	300
0.490 – 1.705	24000/F(kHz)	30
1.705 – 30.0	30	30
30 – 88	100	3
88 – 216	150	3
216 - 960	200	3
Above 960	500	3

#### 3.5.2 Measuring Instruments

See list of measuring equipment of this test report.



### 3.5.3 Test Procedures

1. The testing follows the ANSI C63.10 Section 11.12.1 Radiated emission measurements.
2. The EUT was arranged to its worst case and then tune the antenna tower (from 1 m to 4 m) and turntable (from 0 degree to 360 degrees) to find the maximum reading. A pre-amp and a high pass filter are used for the test in order to get better signal level.
3. The EUT was placed on a turntable with 0.8 meter for frequency below 1GHz and 1.5 meter for frequency above 1GHz respectively above ground.
4. The EUT was set 3 meters from the interference receiving antenna, which was mounted on the top of a variable height antenna tower.
5. Corrected Reading: Antenna Factor + Cable Loss + Read Level - Preamp Factor = Level
6. For testing below 1GHz, if the emission level of the EUT in peak mode was 3 dB lower than the limit specified, then peak values of EUT will be reported, otherwise, the emissions will be repeated one by one using the CISPR quasi-peak method and reported.
7. For testing above 1GHz, the emission level of the EUT in peak mode was 20dB lower than average limit (that means the emission level in average mode also complies with the limit in average mode), then peak values of EUT will be reported, otherwise, the emissions will be measured in average mode again and reported.
8. Use the following spectrum analyzer settings:
  - (1) Span shall wide enough to fully capture the emission being measured;
  - (2) Set RBW=100 kHz for  $f < 1$  GHz;  $VBW \geq RBW$ ; Sweep = auto; Detector function = peak; Trace = max hold;
  - (3) Set RBW = 1 MHz, VBW= 3MHz for  $f \geq 1$  GHz for peak measurement.  
For average measurement:
    - $VBW = 10$  Hz, when duty cycle is no less than 98 percent.
    - $VBW \geq 1/T$ , when duty cycle is less than 98 percent where T is the minimum transmission duration over which the transmitter is on and is transmitting at its maximum power control level for the tested mode of operation.

### 3.5.4 Test Setup

For radiated emissions below 30MHz

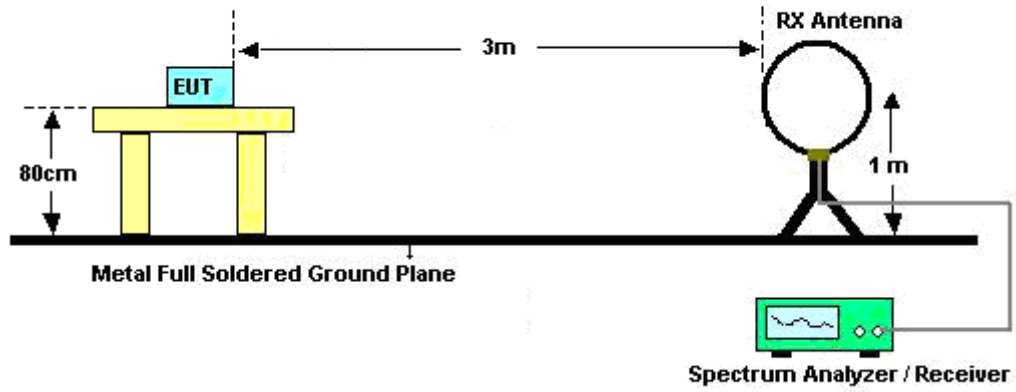

For radiated emissions from 30MHz to 1GHz

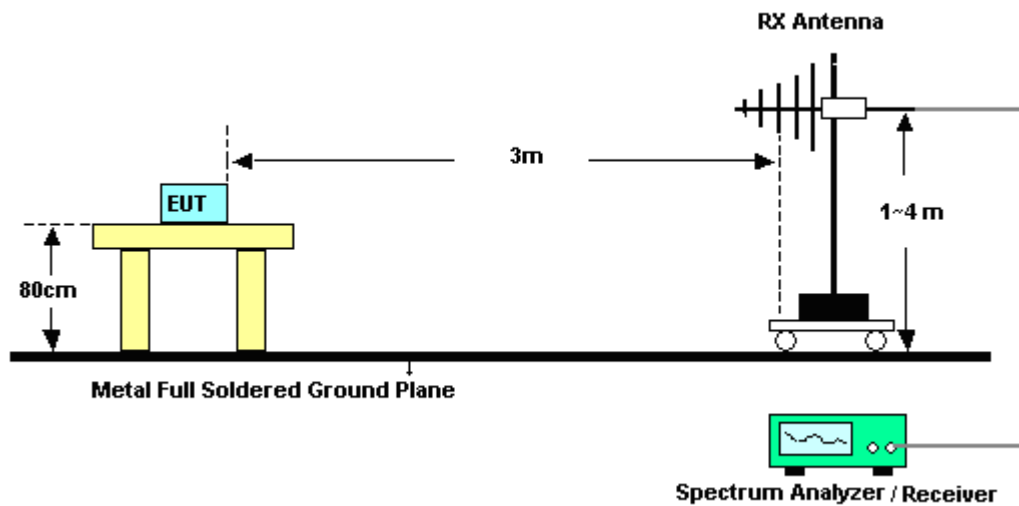

For radiated emissions above 1GHz

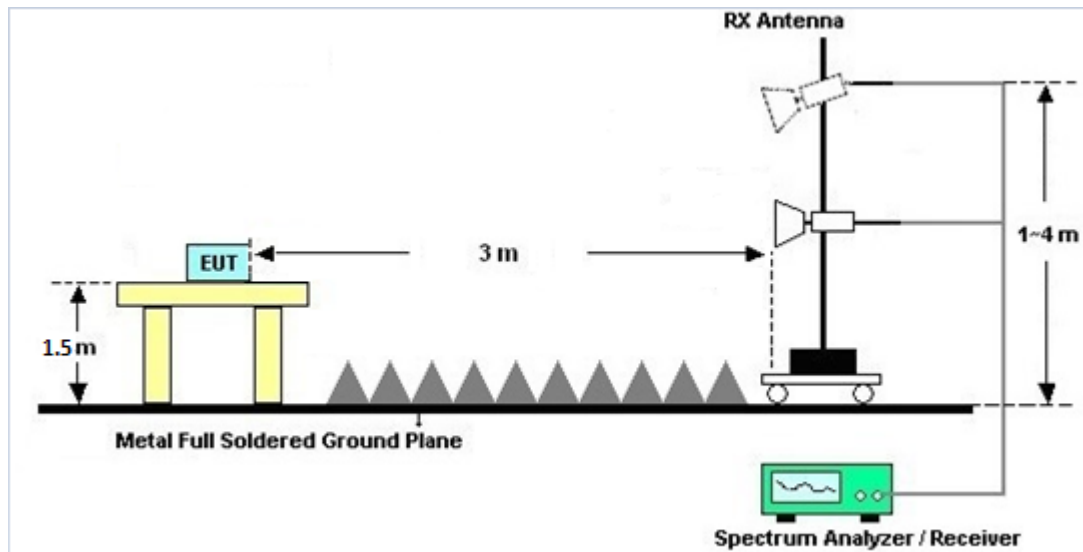

### 3.5.5 Test Results of Radiated Spurious Emissions (9kHz ~ 30MHz)

The low frequency, which started from 9 kHz to 30MHz, was pre-scanned and the result which was 20dB lower than the limit line was not reported.

There is a comparison data of both open-field test site and alternative test site - semi-Anechoic chamber according to 414788 D01 Radiated Test Site v01r01, and the result came out very similar.

### 3.5.6 Test Result of Radiated Spurious at Band Edges

Please refer to Appendix B and C.

### 3.5.7 Duty Cycle

Please refer to Appendix D.

### 3.5.8 Test Result of Radiated Spurious Emission (30MHz ~ 10<sup>th</sup> Harmonic)

Please refer to Appendix B and C.



### 3.6 Antenna Requirements

#### 3.6.1 Standard Applicable

If directional gain of transmitting Antennas is greater than 6dBi, the power shall be reduced by the same level in dB comparing to gain minus 6dBi. The use of a permanently attached Antenna or of an Antenna that uses a unique coupling to the intentional radiator shall be considered sufficient to comply with the rule.

#### 3.6.2 Antenna Anti-Replacement Construction

An embedded-in antenna design is used.

#### 3.6.3 Antenna Gain

<CDD Modes >

FCC KDB 662911 D01 Multiple Transmitter Output v02r01

For CDD transmissions, directional gain is calculated as

Directional gain =  $G_{ANT}$  + Array Gain, where Array Gain is as follows.

For power spectral density (PSD) measurements on all devices,

Array Gain =  $10 \log(N_{ANT}/N_{SS}=1)$  dB.

For power measurements on IEEE 802.11 devices,

Array Gain = 0 dB (i.e., no array gain) for  $N_{ANT} \leq 4$ .

Directional gain may be calculated by using the formulas applicable to equal gain antennas with  $G_{ANT}$  set equal to the gain of the antenna having the highest gain;

The EUT supports CDD mode.

For power, the directional gain  $G_{ANT}$  is set equal to the antenna having the highest gain, i.e., F)2)f)i).

For PSD, the directional gain calculation is following F)2)f)ii) of KDB 662911 D01 v02r01.

The power and PSD limit should be modified if the directional gain of EUT is over 6 dBi,

The directional gain "DG" is calculated as following table.



#### <CDD Modes>

	Ant. 0 (dBi)	Ant. 1 (dBi)	DG for Power (dBi)	DG for PSD (dBi)	Power Limit Reduction (dB)	PSD Limit Reduction (dB)
2.4 GHz	1.58	1.58	1.58	4.59	0.00	0.00

$Power\ Limit\ Reduction = DG(Power) - 6dBi, (min = 0)$

$PSD\ Limit\ Reduction = DG(PSD) - 6dBi, (min = 0)$



## 4 List of Measuring Equipment

Instrument	Brand Name	Model No.	Serial No.	Characteristics	Calibration Date	Test Date	Due Date	Remark
Hygrometer	Testo	608-H1	34893241	N/A	Mar. 02, 2020	Sep. 22, 2020~ Sep. 28, 2020	Mar. 01, 2021	Conducted (TH05-HY)
Power Sensor	DARE	RPR3006W	16I00054S NO10	10MHz~6GHz	Dec. 23, 2019	Sep. 22, 2020~ Sep. 28, 2020	Dec. 22, 2020	Conducted (TH05-HY)
Spectrum Analyzer	Rohde & Schwarz	FSP40	100055	9kHz-40GHz	Dec. 30, 2019	Sep. 22, 2020~ Sep. 28, 2020	Dec. 29, 2020	Conducted (TH05-HY)
Switch Box & RF Cable	EM Electronics	EMSW18SE	SW200302	N/A	Mar. 17, 2020	Sep. 22, 2020~ Sep. 28, 2020	Mar. 16, 2021	Conducted (TH05-HY)
Loop Antenna	Rohde & Schwarz	HFH2-Z2	100488	9 kHz~30 MHz	Jan. 09, 2020	Sep. 27, 2020~ Sep. 29, 2020	Jan. 08, 2021	Radiation (03CH15-HY)
Bilog Antenna	TESEQ	CBL6111D&0 0800N1D01N- 06	41912&05	30MHz to 1GHz	Feb. 09, 2020	Sep. 27, 2020~ Sep. 29, 2020	Feb. 08, 2021	Radiation (03CH15-HY)
Amplifier	SONOMA	310N	363440	9kHz~1GHz	Dec. 27, 2019	Sep. 27, 2020~ Sep. 29, 2020	Dec. 26, 2020	Radiation (03CH15-HY)
Horn Antenna	SCHWARZBECK	BBHA 9120 D	9120D-162 0	1-18GHz	Oct. 28, 2019	Sep. 27, 2020~ Sep. 29, 2020	Oct. 27, 2020	Radiation (03CH15-HY)
SHF-EHF Horn Antenna	SCHWARZBECK	BBHA 9170	BBHA9170 584	18GHz- 40GHz	Dec. 10, 2019	Sep. 27, 2020~ Sep. 29, 2020	Dec. 09, 2020	Radiation (03CH15-HY)
Preamplifier	Jet-Power	JPA0118-55-3 03	171000180 0055006	1GHz~18GHz	May 07, 2020	Sep. 27, 2020~ Sep. 29, 2020	May 06, 2021	Radiation (03CH15-HY)
Preamplifier	Keysight	83017A	MY532701 95	1GHz~26.5GHz	Aug. 21, 2020	Sep. 27, 2020~ Sep. 29, 2020	Aug. 20, 2021	Radiation (03CH15-HY)
Preamplifier	EMEC	EM18G40G	060715	18GHz ~ 40GHz	Dec. 13, 2019	Sep. 27, 2020~ Sep. 29, 2020	Dec. 12, 2020	Radiation (03CH15-HY)
EMI Test Receiver	Keysight	N9038A(MXE )	MY541300 85	20MHz~8.4GHz	Nov. 01, 2019	Sep. 27, 2020~ Sep. 29, 2020	Oct. 31, 2020	Radiation (03CH15-HY)
Spectrum Analyzer	Agilent	E4446A	MY501801 36	3Hz~44GHz	May 04, 2020	Sep. 27, 2020~ Sep. 29, 2020	May 03, 2021	Radiation (03CH15-HY)
Antenna Mast	ChainTek	MBS-520-1	N/A	1m~4m	N/A	Sep. 27, 2020~ Sep. 29, 2020	N/A	Radiation (03CH15-HY)
Turn Table	ChainTek	T-200-S-1	N/A	0~360 Degree	N/A	Sep. 27, 2020~ Sep. 29, 2020	N/A	Radiation (03CH15-HY)
Software	Audix	E3 6.2009-8-24(k 5)	RK-00045 1	N/A	N/A	Sep. 27, 2020~ Sep. 29, 2020	N/A	Radiation (03CH15-HY)
RF Cable	HUBER + SUHNER	SUCOFLEX 104	MY36980/ 4	30M-18G	Apr. 14, 2020	Sep. 27, 2020~ Sep. 29, 2020	Apr. 13, 2021	Radiation (03CH15-HY)
RF Cable	HUBER + SUHNER	SUCOFLEX 104	MY9838/4 PE	30M-18G	Apr. 14, 2020	Sep. 27, 2020~ Sep. 29, 2020	Apr. 13, 2021	Radiation (03CH15-HY)
RF Cable	HUBER + SUHNER	SUCOFLEX 104	MY37710/ 4	30M-18G	Apr. 17, 2020	Sep. 27, 2020~ Sep. 29, 2020	Apr. 16, 2021	Radiation (03CH15-HY)
RF Cable	HUBER + SUHNER	SUCOFLEX 102	505134/2	30MHz-40GHz	Feb. 25, 2020	Sep. 27, 2020~ Sep. 29, 2020	Feb. 24, 2021	Radiation (03CH15-HY)
RF Cable	HUBER + SUHNER	SUCOFLEX 102	800740/2	30MHz-40GHz	Feb. 25, 2020	Sep. 27, 2020~ Sep. 29, 2020	Feb. 24, 2021	Radiation (03CH15-HY)
RF Cable	HUBER + SUHNER	SUCOFLEX 104	MY9837/4 PE	9kHz~30MHz	Mar. 12, 2020	Sep. 27, 2020~ Sep. 29, 2020	Mar. 11, 2021	Radiation (03CH15-HY)
Filter	Wainwright	WLK4-1000-1 530-8000-40S S	SN4	1.53G Low Pass	Jul. 03, 2020	Sep. 27, 2020~ Sep. 29, 2020	Jul. 02, 2021	Radiation (03CH15-HY)
Filter	Wainwright	WHKX12-270 0-3000-18000 -60ST	SN4	3GHz High Pass Filter	Sep. 16, 2020	Sep. 27, 2020~ Sep. 29, 2020	Sep. 15, 2021	Radiation (03CH15-HY)



## 5 Uncertainty of Evaluation

### Uncertainty of Radiated Emission Measurement (30 MHz ~ 1000 MHz)

Measuring Uncertainty for a Level of Confidence of 95% ( $U = 2Uc(y)$ )	5.0
---	-----

### Uncertainty of Radiated Emission Measurement (1000 MHz ~ 18000 MHz)

Measuring Uncertainty for a Level of Confidence of 95% ( $U = 2Uc(y)$ )	5.4
---	-----

### Uncertainty of Radiated Emission Measurement (18000 MHz ~ 40000 MHz)

Measuring Uncertainty for a Level of Confidence of 95% ( $U = 2Uc(y)$ )	5.0
---	-----



**Appendix A. Test Result of Conducted Test Items**

Test Engineer:	Mina Liu	Temperature:	23.6~23.7	°C
Test Date:	2020/09/22~2020/09/28	Relative Humidity:	53.5~54.1	%

**TEST RESULTS DATA**  
**6dB and 99% Occupied Bandwidth**

2.4GHz Band MIMO										
Mod.	Data Rate	NTX	CH.	Freq. (MHz)	99% Occupied BW (MHz)		6dB BW (MHz)		6dB BW Limit (MHz)	Pass/Fail
					Ant0	Ant1	Ant0	Ant1		
11b	1Mbps	2	1	2412	12.75	12.90	7.56	7.54	0.50	Pass
11b	1Mbps	2	6	2437	12.95	12.95	7.54	7.02	0.50	Pass
11b	1Mbps	2	11	2462	12.85	12.85	8.04	8.00	0.50	Pass
11g	6Mbps	2	1	2412	16.40	16.40	15.60	15.62	0.50	Pass
11g	6Mbps	2	6	2437	16.50	16.45	16.02	16.28	0.50	Pass
11g	6Mbps	2	11	2462	16.40	16.35	16.02	15.68	0.50	Pass

**TEST RESULTS DATA**  
**6dB and 99% Occupied Bandwidth**

2.4GHz Band MIMO											
Mod.	Data Rate	Ntx	CH.	Freq. (MHz)	RU Config.	99% Occupied BW (MHz)		6dB BW (MHz)		6dB BW Limit (MHz)	Pass/Fail
						Ant0	Ant1	Ant0	Ant1		
HE20	MCS0	2	1	2412	Full	18.85	18.90	17.20	17.40	0.50	Pass
HE20	MCS0	2	6	2437	Full	19.00	18.95	18.68	18.52	0.50	Pass
HE20	MCS0	2	11	2462	Full	18.90	18.90	18.20	17.74	0.50	Pass
HE40	MCS0	2	3	2422	Full	37.40	37.60	35.00	34.16	0.50	Pass
HE40	MCS0	2	6	2437	Full	38.30	38.10	37.84	37.88	0.50	Pass
HE40	MCS0	2	9	2452	Full	37.90	38.00	34.64	37.56	0.50	Pass

**TEST RESULTS DATA**  
**Average Output Power**

2.4GHz Band Single Antenna																
Mod.	Data Rate	NTX	CH.	Freq. (MHz)	Average Conducted Power (dBm)			Conducted Power Limit (dBm)		DG (dBi)		EIRP Power (dBm)		EIRP Power Limit (dBm)		Pass /Fail
					Ant0	Ant1	SUM	Ant0	Ant1	Ant0	Ant1	Ant0	Ant1	Ant0	Ant1	
11b	1Mbps	1	1	2412	13.80	13.60		30.00	30.00	1.58	1.58	15.38	15.18	36.00	36.00	Pass
11b	1Mbps	1	6	2437	13.80	13.50		30.00	30.00	1.58	1.58	15.38	15.08	36.00	36.00	Pass
11b	1Mbps	1	11	2462	13.60	13.50		30.00	30.00	1.58	1.58	15.18	15.08	36.00	36.00	Pass
11g	6Mbps	1	1	2412	13.70	13.80		30.00	30.00	1.58	1.58	15.28	15.38	36.00	36.00	Pass
11g	6Mbps	1	6	2437	13.70	13.60		30.00	30.00	1.58	1.58	15.28	15.18	36.00	36.00	Pass
11g	6Mbps	1	11	2462	13.50	13.60		30.00	30.00	1.58	1.58	15.08	15.18	36.00	36.00	Pass
HT20	MCS0	1	1	2412	13.50	13.60		30.00	30.00	1.58	1.58	15.08	15.18	36.00	36.00	Pass
HT20	MCS0	1	6	2437	13.60	13.50		30.00	30.00	1.58	1.58	15.18	15.08	36.00	36.00	Pass
HT20	MCS0	1	11	2462	13.50	13.50		30.00	30.00	1.58	1.58	15.08	15.08	36.00	36.00	Pass
HT40	MCS0	1	3	2422	13.50	13.60		30.00	30.00	1.58	1.58	15.08	15.18	36.00	36.00	Pass
HT40	MCS0	1	6	2437	13.50	13.50		30.00	30.00	1.58	1.58	15.08	15.08	36.00	36.00	Pass
HT40	MCS0	1	9	2452	13.50	13.50		30.00	30.00	1.58	1.58	15.08	15.08	36.00	36.00	Pass
VHT20	MCS0	1	1	2412	13.50	13.60		30.00	30.00	1.58	1.58	15.08	15.18	36.00	36.00	Pass
VHT20	MCS0	1	6	2437	13.60	13.50		30.00	30.00	1.58	1.58	15.18	15.08	36.00	36.00	Pass
VHT20	MCS0	1	11	2462	13.50	13.50		30.00	30.00	1.58	1.58	15.08	15.08	36.00	36.00	Pass
VHT40	MCS0	1	3	2422	13.50	13.60		30.00	30.00	1.58	1.58	15.08	15.18	36.00	36.00	Pass
VHT40	MCS0	1	6	2437	13.50	13.50		30.00	30.00	1.58	1.58	15.08	15.08	36.00	36.00	Pass
VHT40	MCS0	1	9	2452	13.50	13.50		30.00	30.00	1.58	1.58	15.08	15.08	36.00	36.00	Pass

2.4GHz Band MIMO																
Mod.	Data Rate	N <sub>Tx</sub>	CH.	Freq. (MHz)	Average Conducted Power (dBm)			Conducted Power Limit (dBm)		DG (dBi)		EIRP Power (dBm)		EIRP Power Limit (dBm)		Pass /Fail
					Ant0	Ant1	SUM	Ant0	Ant1	Ant0	Ant1	Ant0	Ant1	Ant0	Ant1	
11b	1Mbps	2	1	2412	13.90	13.90	16.91	30.00		1.58		18.49		36.00	Pass	
11b	1Mbps	2	6	2437	13.90	13.80	16.86	30.00		1.58		18.44		36.00	Pass	
11b	1Mbps	2	11	2462	13.80	13.70	16.76	30.00		1.58		18.34		36.00	Pass	
11g	6Mbps	2	1	2412	13.80	13.90	16.86	30.00		1.58		18.44		36.00	Pass	
11g	6Mbps	2	6	2437	13.80	13.70	16.76	30.00		1.58		18.34		36.00	Pass	
11g	6Mbps	2	11	2462	13.70	13.70	16.71	30.00		1.58		18.29		36.00	Pass	
HT20	MCS0	2	1	2412	13.80	13.80	16.81	30.00		1.58		18.39		36.00	Pass	
HT20	MCS0	2	6	2437	13.70	13.60	16.66	30.00		1.58		18.24		36.00	Pass	
HT20	MCS0	2	11	2462	13.80	13.80	16.81	30.00		1.58		18.39		36.00	Pass	
HT40	MCS0	2	3	2422	13.80	13.80	16.81	30.00		1.58		18.39		36.00	Pass	
HT40	MCS0	2	6	2437	13.80	13.60	16.71	30.00		1.58		18.29		36.00	Pass	
HT40	MCS0	2	9	2452	13.70	13.80	16.76	30.00		1.58		18.34		36.00	Pass	
VHT20	MCS0	2	1	2412	13.80	13.80	16.81	30.00		1.58		18.39		36.00	Pass	
VHT20	MCS0	2	6	2437	13.70	13.60	16.66	30.00		1.58		18.24		36.00	Pass	
VHT20	MCS0	2	11	2462	13.80	13.80	16.81	30.00		1.58		18.39		36.00	Pass	
VHT40	MCS0	2	3	2422	13.80	13.80	16.81	30.00		1.58		18.39		36.00	Pass	
VHT40	MCS0	2	6	2437	13.80	13.60	16.71	30.00		1.58		18.29		36.00	Pass	
VHT40	MCS0	2	9	2452	13.70	13.80	16.76	30.00		1.58		18.34		36.00	Pass	

Note: Measured power (dBm) has offset with cable loss.

**TEST RESULTS DATA**  
**Average Output Power**

2.4GHz Band Single Antenna																	
Mod.	Data Rate	Ntx	CH.	Freq. (MHz)	RU Config.	Average Conducted Power (dBm)			Conducted Power Limit (dBm)		DG (dBi)		EIRP Power (dBm)		EIRP Power Limit (dBm)		Pass /Fail
						Ant0	Ant1	SUM	Ant0	Ant1	Ant0	Ant1	Ant0	Ant1	Ant0	Ant1	
HE20	MCS0	1	1	2412	Full	13.60	13.70		30.00	30.00	1.58	1.58	15.18	15.28	36.00	36.00	Pass
HE20	MCS0	1	1	2412	26/0	5.60	6.40		30.00	30.00	1.58	1.58	7.18	7.98	36.00	36.00	Pass
HE20	MCS0	1	1	2412	52/37	7.40	8.10		30.00	30.00	1.58	1.58	8.98	9.68	36.00	36.00	Pass
HE20	MCS0	1	1	2412	106/53	10.40	10.50		30.00	30.00	1.58	1.58	11.98	12.08	36.00	36.00	Pass
HE20	MCS0	1	6	2437	Full	13.70	13.60		30.00	30.00	1.58	1.58	15.28	15.18	36.00	36.00	Pass
HE20	MCS0	1	6	2437	26/4	5.60	5.90		30.00	30.00	1.58	1.58	7.18	7.48	36.00	36.00	Pass
HE20	MCS0	1	6	2437	52/39	8.40	8.40		30.00	30.00	1.58	1.58	9.98	9.98	36.00	36.00	Pass
HE20	MCS0	1	6	2437	106/53	11.00	10.90		30.00	30.00	1.58	1.58	12.58	12.48	36.00	36.00	Pass
HE20	MCS0	1	11	2462	Full	13.60	13.60		30.00	30.00	1.58	1.58	15.18	15.18	36.00	36.00	Pass
HE20	MCS0	1	11	2462	26/8	5.50	6.10		30.00	30.00	1.58	1.58	7.08	7.68	36.00	36.00	Pass
HE20	MCS0	1	11	2462	52/40	7.30	8.00		30.00	30.00	1.58	1.58	8.88	9.58	36.00	36.00	Pass
HE20	MCS0	1	11	2462	106/54	10.50	11.20		30.00	30.00	1.58	1.58	12.08	12.78	36.00	36.00	Pass
HE40	MCS0	1	3	2422	Full	13.60	13.70		30.00	30.00	1.58	1.58	15.18	15.28	36.00	36.00	Pass
HE40	MCS0	1	3	2422	242/61	11.90	11.90		30.00	30.00	1.58	1.58	13.48	13.48	36.00	36.00	Pass
HE40	MCS0	1	6	2437	Full	13.60	13.60		30.00	30.00	1.58	1.58	15.18	15.18	36.00	36.00	Pass
HE40	MCS0	1	6	2437	242/61	11.80	11.70		30.00	30.00	1.58	1.58	13.38	13.28	36.00	36.00	Pass
HE40	MCS0	1	9	2452	Full	13.60	13.60		30.00	30.00	1.58	1.58	15.18	15.18	36.00	36.00	Pass
HE40	MCS0	1	9	2452	242/62	11.40	11.70		30.00	30.00	1.58	1.58	12.98	13.28	36.00	36.00	Pass

2.4GHz Band MIMO																	
Mod.	Data Rate	Ntx	CH.	Freq. (MHz)	RU Config.	Average Conducted Power (dBm)			Conducted Power Limit (dBm)		DG (dBi)		EIRP Power (dBm)		EIRP Power Limit (dBm)		Pass /Fail
						Ant0	Ant1	SUM	Ant0	Ant1	Ant0	Ant1	Ant0	Ant1	Ant0	Ant1	
HE20	MCS0	2	1	2412	Full	13.90	13.90	16.91	30.00		1.58		18.49		36.00		Pass
HE20	MCS0	2	1	2412	26/0	5.70	6.50	9.13	30.00		1.58		10.71		36.00		Pass
HE20	MCS0	2	1	2412	52/37	7.50	8.20	10.87	30.00		1.58		12.45		36.00		Pass
HE20	MCS0	2	1	2412	106/53	10.50	10.80	13.66	30.00		1.58		15.24		36.00		Pass
HE20	MCS0	2	6	2437	Full	13.80	13.70	16.76	30.00		1.58		18.34		36.00		Pass
HE20	MCS0	2	6	2437	26/4	5.70	6.00	8.86	30.00		1.58		10.44		36.00		Pass
HE20	MCS0	2	6	2437	52/39	8.50	8.50	11.51	30.00		1.58		13.09		36.00		Pass
HE20	MCS0	2	6	2437	106/53	11.10	11.10	14.11	30.00		1.58		15.69		36.00		Pass
HE20	MCS0	2	11	2462	Full	13.90	13.90	16.91	30.00		1.58		18.49		36.00		Pass
HE20	MCS0	2	11	2462	26/8	5.60	6.20	8.92	30.00		1.58		10.50		36.00		Pass
HE20	MCS0	2	11	2462	52/40	7.40	8.10	10.77	30.00		1.58		12.35		36.00		Pass
HE20	MCS0	2	11	2462	106/54	10.60	11.30	13.97	30.00		1.58		15.55		36.00		Pass
HE40	MCS0	2	3	2422	Full	13.90	13.90	16.91	30.00		1.58		18.49		36.00		Pass
HE40	MCS0	2	3	2422	242/61	12.10	12.10	15.11	30.00		1.58		16.69		36.00		Pass
HE40	MCS0	2	6	2437	Full	13.90	13.70	16.81	30.00		1.58		18.39		36.00		Pass
HE40	MCS0	2	6	2437	242/61	12.00	11.90	14.96	30.00		1.58		16.54		36.00		Pass
HE40	MCS0	2	9	2452	Full	13.80	13.90	16.86	30.00		1.58		18.44		36.00		Pass
HE40	MCS0	2	9	2452	242/62	11.60	11.90	14.76	30.00		1.58		16.34		36.00		Pass

Note: Measured power (dBm) has offset with cable loss.

**TEST RESULTS DATA**  
**Peak Power Spectral Density**

2.4GHz Band MIMO												
Mod.	Data Rate	NTX	CH.	Freq. (MHz)	Peak PSD (dBm/3kHz)			DG (dBi)		Peak PSD Limit (dBm/3kHz)		Pass/Fail
					Ant0	Ant1	Worse + 3.01	Ant0	Ant1	Ant0	Ant1	
11b	1Mbps	2	1	2412	-10.27	-10.73	-7.26	4.59		8.00		Pass
11b	1Mbps	2	6	2437	-10.50	-10.53	-7.49	4.59		8.00		Pass
11b	1Mbps	2	11	2462	-10.68	-10.29	-7.28	4.59		8.00		Pass
11g	6Mbps	2	1	2412	-13.69	-13.66	-10.65	4.59		8.00		Pass
11g	6Mbps	2	6	2437	-13.76	-13.78	-10.75	4.59		8.00		Pass
11g	6Mbps	2	11	2462	-13.77	-14.01	-10.76	4.59		8.00		Pass

Note: Measured power density (dBm) has offset with cable loss.



**TEST RESULTS DATA**  
**Peak Power Spectral Density**

2.4GHz Band MIMO													
Mod.	Data Rate	Ntx	CH.	Freq. (MHz)	RU Config.	Peak PSD (dBm/3kHz)			DG (dBi)		Peak PSD Limit (dBm/3kHz)		Pass/Fail
						Ant0	Ant1	Worse + 3.01	Ant0	Ant1	Ant0	Ant1	
HE20	MCS0	2	1	2412	Full	-11.83	-11.76	-8.75	4.59		8.00		Pass
HE20	MCS0	2	1	2412	26/0	-12.31	-12.15	-9.14	4.59		8.00		Pass
HE20	MCS0	2	1	2412	52/37	-11.85	-11.87	-8.84	4.59		8.00		Pass
HE20	MCS0	2	1	2412	106/53	-12.09	-12.05	-9.04	4.59		8.00		Pass
HE20	MCS0	2	6	2437	Full	-12.36	-12.13	-9.12	4.59		8.00		Pass
HE20	MCS0	2	6	2437	26/4	-12.44	-12.15	-9.14	4.59		8.00		Pass
HE20	MCS0	2	6	2437	52/39	-12.45	-12.38	-9.37	4.59		8.00		Pass
HE20	MCS0	2	6	2437	106/53	-12.71	-12.40	-9.39	4.59		8.00		Pass
HE20	MCS0	2	11	2462	Full	-12.21	-12.24	-9.20	4.59		8.00		Pass
HE20	MCS0	2	11	2462	26/8	-12.31	-12.57	-9.30	4.59		8.00		Pass
HE20	MCS0	2	11	2462	52/40	-12.67	-12.69	-9.66	4.59		8.00		Pass
HE20	MCS0	2	11	2462	106/54	-12.69	-12.56	-9.55	4.59		8.00		Pass
HE40	MCS0	2	3	2422	Full	-13.88	-13.74	-10.73	4.59		8.00		Pass
HE40	MCS0	2	3	2422	242/61	-13.92	-14.05	-10.91	4.59		8.00		Pass
HE40	MCS0	2	6	2437	Full	-14.03	-14.37	-11.02	4.59		8.00		Pass
HE40	MCS0	2	6	2437	242/61	-14.36	-14.59	-11.35	4.59		8.00		Pass
HE40	MCS0	2	9	2452	Full	-14.24	-14.59	-11.23	4.59		8.00		Pass
HE40	MCS0	2	9	2452	242/62	-14.57	-14.64	-11.56	4.59		8.00		Pass

Note: Measured power density (dBm) has offset with cable loss.



## Appendix B. Radiated Spurious Emission

Test Engineer :	Leo Lee, Mancy Chou and Bigshow Wang	Temperature :	22.3~23.1°C
		Relative Humidity :	48~55%

### 2.4GHz 2400~2483.5MHz

#### WIFI 802.11b (Band Edge @ 3m)

WIFI	Note	Frequency	Level	Over	Limit	Read	Antenna	Path	Preamp	Ant	Table	Peak	Pol.	
Ant.				Limit	Line	Level	Factor	Loss	Factor	Pos	Pos	Avg.		
0+1		( MHz )	( dBμV/m )	( dB )	( dBμV/m )	( dBμV )	( dB/m )	( dB )	( dB )	( cm )	( deg )	( P/A )	( H/V )	
802.11b CH 01 2412MHz		2374.365	56.29	-17.71	74	42.04	27.85	17.32	30.92	100	190	P	H	
		2390	45.32	-8.68	54	31.13	27.76	17.35	30.92	100	190	A	H	
	*	2412	109.29	-	-	95.13	27.68	17.39	30.91	100	190	P	H	
	*	2412	106.38	-	-	92.22	27.68	17.39	30.91	100	190	A	H	
													H	
														H
			2333.625	56.65	-17.35	74	42.33	28.03	17.23	30.94	395	288	P	V
			2330.16	45.15	-8.85	54	30.82	28.04	17.23	30.94	395	288	A	V
	*		2412	108.88	-	-	94.72	27.68	17.39	30.91	395	288	P	V
	*		2412	105.92	-	-	91.76	27.68	17.39	30.91	395	288	A	V
														V
														V
802.11b CH 06 2437MHz		2375.62	57.21	-16.79	74	42.96	27.85	17.32	30.92	100	192	P	H	
		2390	45.32	-8.68	54	31.13	27.76	17.35	30.92	100	192	A	H	
	*	2437	109.8	-	-	95.64	27.63	17.43	30.9	100	192	P	H	
	*	2437	106.67	-	-	92.51	27.63	17.43	30.9	100	192	A	H	
			2486.41	55.95	-18.05	74	41.78	27.53	17.52	30.88	100	192	P	H
			2483.8	45.29	-8.71	54	31.12	27.53	17.52	30.88	100	192	A	H
			2318.33	56.71	-17.29	74	42.4	28.06	17.2	30.95	340	291	P	V
			2335.84	45.15	-8.85	54	30.82	28.03	17.24	30.94	340	291	A	V
	*		2437	109.12	-	-	94.96	27.63	17.43	30.9	340	291	P	V
	*		2437	106	-	-	91.84	27.63	17.43	30.9	340	291	A	V
			2485.96	55.48	-18.52	74	41.31	27.53	17.52	30.88	340	291	P	V
			2483.62	45.12	-8.88	54	30.95	27.53	17.52	30.88	340	291	A	V



<b>802.11b CH 11 2462MHz</b>	*	2462	110.03	-	-	95.86	27.58	17.48	30.89	113	194	P	H
	*	2462	106.98	-	-	92.81	27.58	17.48	30.89	113	194	A	H
		2495.8	56.24	-17.76	74	42.06	27.51	17.54	30.87	113	194	P	H
		2483.52	45.69	-8.31	54	31.52	27.53	17.52	30.88	113	194	A	H
													H
													H
	*	2462	107.69	-	-	93.52	27.58	17.48	30.89	301	284	P	V
	*	2462	104.5	-	-	90.33	27.58	17.48	30.89	301	284	A	V
		2495.32	55.99	-18.01	74	41.81	27.51	17.54	30.87	301	284	P	V
		2483.68	45.21	-8.79	54	31.04	27.53	17.52	30.88	301	284	A	V
													V
													V
<b>Remark</b>	1. No other spurious found. 2. All results are PASS against Peak and Average limit line.												



**2.4GHz 2400~2483.5MHz  
WIFI 802.11b (Harmonic @ 3m)**

WIFI Ant. 0+1	Note	Frequency ( MHz )	Level ( dBµV/m )	Over Limit ( dB )	Limit Line ( dBµV/m )	Read Level ( dBµV )	Antenna Factor ( dB/m )	Path Loss ( dB )	Preamp Factor ( dB )	Ant Pos ( cm )	Table Pos ( deg )	Peak Avg. ( P/A )	Pol. ( H/V )	
802.11b CH 01 2412MHz		4824	40.38	-33.62	74	57.61	31.25	10.61	59.09	100	0	P	H	
													H	
													H	
													H	
			4824	40.5	-33.5	74	57.73	31.25	10.61	59.09	100	0	P	V
														V
														V
802.11b CH 06 2437MHz		4874	40.02	-33.98	74	57.27	31.25	10.62	59.12	100	0	P	H	
		7311	45.02	-28.98	74	54.47	36.52	12.59	58.56	100	0	P	H	
													H	
													H	
			4874	39.74	-34.26	74	56.99	31.25	10.62	59.12	100	0	P	V
			7311	45.74	-28.26	74	55.19	36.52	12.59	58.56	100	0	P	V
														V
802.11b CH 11 2462MHz		4924	40.38	-33.62	74	57.57	31.34	10.62	59.15	100	0	P	H	
		7386	44.51	-29.49	74	53.8	36.46	12.71	58.46	100	0	P	H	
													H	
													H	
			4924	41.58	-32.42	74	58.77	31.34	10.62	59.15	100	0	P	V
			7386	44.5	-29.5	74	53.79	36.46	12.71	58.46	100	0	P	V
														V
Remark	1. No other spurious found.													
	2. All results are PASS against Peak and Average limit line.													



**2.4GHz 2400~2483.5MHz  
WIFI 802.11g (Band Edge @ 3m)**

WIFI Ant. 0+1	Note	Frequency ( MHz )	Level ( dBμV/m )	Over Limit ( dB )	Limit Line ( dBμV/m )	Read Level ( dBμV )	Antenna Factor ( dB/m )	Path Loss ( dB )	Preamp Factor ( dB )	Ant Pos ( cm )	Table Pos ( deg )	Peak Avg. ( P/A )	Pol. ( H/V )	
802.11g CH 01 2412MHz		2389.59	61.34	-12.66	74	47.15	27.76	17.35	30.92	100	338	P	H	
		2390	48.67	-5.33	54	34.48	27.76	17.35	30.92	100	338	A	H	
	*	2412	111.46	-	-	97.3	27.68	17.39	30.91	100	338	P	H	
	*	2412	104.03	-	-	89.87	27.68	17.39	30.91	100	338	A	H	
													H	
														H
			2348.325	57.16	-16.84	74	42.83	28	17.26	30.93	390	287	P	V
			2388.855	45.62	-8.38	54	31.43	27.77	17.34	30.92	390	287	A	V
	*		2412	111.34	-	-	97.18	27.68	17.39	30.91	390	287	P	V
	*		2412	103.7	-	-	89.54	27.68	17.39	30.91	390	287	A	V
														V
														V
802.11g CH 06 2437MHz		2325.98	56.77	-17.23	74	42.44	28.05	17.22	30.94	100	339	P	H	
		2340.6	45.16	-8.84	54	30.83	28.02	17.25	30.94	100	339	A	H	
	*	2437	112.52	-	-	98.36	27.63	17.43	30.9	100	339	P	H	
	*	2437	104.31	-	-	90.15	27.63	17.43	30.9	100	339	A	H	
			2495.59	56.32	-17.68	74	42.14	27.51	17.54	30.87	100	339	P	H
			2483.53	45.2	-8.8	54	31.03	27.53	17.52	30.88	100	339	A	H
			2388.88	56.64	-17.36	74	42.45	27.77	17.34	30.92	343	290	P	V
			2343.32	45.13	-8.87	54	30.81	28.01	17.25	30.94	343	290	A	V
	*		2437	111.39	-	-	97.23	27.63	17.43	30.9	343	290	P	V
	*		2437	103.51	-	-	89.35	27.63	17.43	30.9	343	290	A	V
			2487.22	55.75	-18.25	74	41.58	27.53	17.52	30.88	343	290	P	V
			2484.88	45	-9	54	30.83	27.53	17.52	30.88	343	290	A	V



<b>802.11g CH 11 2462MHz</b>	*	2462	113.14	-	-	98.97	27.58	17.48	30.89	125	337	P	H
	*	2462	105.18	-	-	91.01	27.58	17.48	30.89	125	337	A	H
		2483.88	61.62	-12.38	74	47.45	27.53	17.52	30.88	125	337	P	H
		2483.6	49.44	-4.56	54	35.27	27.53	17.52	30.88	125	337	A	H
													H
													H
	*	2462	111.74	-	-	97.57	27.58	17.48	30.89	378	289	P	V
	*	2462	104.06	-	-	89.89	27.58	17.48	30.89	378	289	A	V
		2484.28	58.27	-15.73	74	44.1	27.53	17.52	30.88	378	289	P	V
		2483.52	47.88	-6.12	54	33.71	27.53	17.52	30.88	378	289	A	V
													V
													V
<b>Remark</b>	1. No other spurious found. 2. All results are PASS against Peak and Average limit line.												



**2.4GHz 2400~2483.5MHz  
WIFI 802.11g (Harmonic @ 3m)**

WIFI Ant. 0+1	Note	Frequency ( MHz )	Level ( dBμV/m )	Over Limit ( dB )	Limit Line ( dBμV/m )	Read Level ( dBμV )	Antenna Factor ( dB/m )	Path Loss ( dB )	Preamp Factor ( dB )	Ant Pos ( cm )	Table Pos ( deg )	Peak Avg. ( P/A )	Pol. ( H/V )	
802.11g CH 01 2412MHz		4824	39.9	-34.1	74	57.13	31.25	10.61	59.09	100	0	P	H	
													H	
													H	
													H	
			4824	40.61	-33.39	74	57.84	31.25	10.61	59.09	100	0	P	V
														V
														V
802.11g CH 06 2437MHz		4874	38.91	-35.09	74	56.16	31.25	10.62	59.12	100	0	P	H	
		7311	44.51	-29.49	74	53.96	36.52	12.59	58.56	100	0	P	H	
													H	
													H	
			4874	39.58	-34.42	74	56.83	31.25	10.62	59.12	100	0	P	V
			7311	44.67	-29.33	74	54.12	36.52	12.59	58.56	100	0	P	V
														V
802.11g CH 11 2462MHz		4924	41.37	-32.63	74	58.56	31.34	10.62	59.15	100	0	P	H	
		7386	44.23	-29.77	74	53.52	36.46	12.71	58.46	100	0	P	H	
													H	
													H	
			4924	40.37	-33.63	74	57.56	31.34	10.62	59.15	100	0	P	V
			7386	45.34	-28.66	74	54.63	36.46	12.71	58.46	100	0	P	V
														V
Remark	1. No other spurious found.													
	2. All results are PASS against Peak and Average limit line.													



2.4GHz 2400~2483.5MHz

WIFI 802.11 ax HE20 Full (Band Edge @ 3m)

WIFI Ant. 0+1	Note	Frequency ( MHz )	Level ( dBμV/m )	Over Limit ( dB )	Limit Line ( dBμV/m )	Read Level ( dBμV )	Antenna Factor ( dB/m )	Path Loss ( dB )	Preamp Factor ( dB )	Ant Pos ( cm )	Table Pos ( deg )	Peak Avg. ( P/A )	Pol. ( H/V )	
802.11ax HE20 Full CH 01 2412MHz		2389.905	61.77	-12.23	74	47.58	27.76	17.35	30.92	376	191	P	H	
		2390	50.73	-3.27	54	36.54	27.76	17.35	30.92	376	191	A	H	
	*	2412	113.7	-	-	99.54	27.68	17.39	30.91	376	191	P	H	
	*	2412	103.95	-	-	89.79	27.68	17.39	30.91	376	191	A	H	
													H	
														H
			2390	57.55	-16.45	74	43.36	27.76	17.35	30.92	345	291	P	V
			2390	47.12	-6.88	54	32.93	27.76	17.35	30.92	345	291	A	V
		*	2412	112.09	-	-	97.93	27.68	17.39	30.91	345	291	P	V
		*	2412	102.19	-	-	88.03	27.68	17.39	30.91	345	291	A	V
8802.11ax HE20 Full CH 11 2462MHz													V	
													V	
		*	2462	113.4	-	-	99.23	27.58	17.48	30.89	143	192	P	H
		*	2462	103.77	-	-	89.6	27.58	17.48	30.89	143	192	A	H
			2483.64	62.82	-11.18	74	48.65	27.53	17.52	30.88	143	192	P	H
			2483.52	50.96	-3.04	54	36.79	27.53	17.52	30.88	143	192	A	H
														H
														H
		*	2462	111.78	-	-	97.61	27.58	17.48	30.89	302	284	P	V
		*	2462	101.56	-	-	87.39	27.58	17.48	30.89	302	284	A	V
		2484.44	60.8	-13.2	74	46.63	27.53	17.52	30.88	302	284	P	V	
		2483.52	49.9	-4.1	54	35.73	27.53	17.52	30.88	302	284	A	V	
													V	
													V	
Remark	1. No other spurious found. 2. All results are PASS against Peak and Average limit line.													





**2.4GHz 2400~2483.5MHz  
WIFI 802.11ax HE20 Partial 106 (Band Edge @ 3m)**

WIFI Ant. 0+1	Note	Frequency ( MHz )	Level ( dBμV/m )	Over Limit ( dB )	Limit Line ( dBμV/m )	Read Level ( dBμV )	Antenna Factor ( dB/m )	Path Loss ( dB )	Preamp Factor ( dB )	Ant Pos ( cm )	Table Pos ( deg )	Peak Avg. ( P/A )	Pol. ( H/V )	
802.11ax HE20 Partial 106/53 CH 01 2412MHz		2389.695	60.13	-13.87	74	45.94	27.76	17.35	30.92	100	190	P	H	
		2388.75	45.67	-8.33	54	31.48	27.77	17.34	30.92	100	190	A	H	
	*	2412	112.05	-	-	97.89	27.68	17.39	30.91	100	190	P	H	
	*	2412	102.59	-	-	88.43	27.68	17.39	30.91	100	190	A	H	
													H	
														H
			2389.38	58.94	-15.06	74	44.75	27.76	17.35	30.92	394	287	P	V
			2347.8	45.68	-8.32	54	31.35	28	17.26	30.93	394	287	A	V
	*		2412	110.01	-	-	95.85	27.68	17.39	30.91	394	287	P	V
	*		2412	101.54	-	-	87.38	27.68	17.39	30.91	394	287	A	V
													V	
													V	
802.11ax HE20 Partial 106/54 CH 11 2462MHz	*	2462	112.69	-	-	98.52	27.58	17.48	30.89	142	192	P	H	
	*	2462	103.39	-	-	89.22	27.58	17.48	30.89	142	192	A	H	
			2483.6	62.82	-11.18	74	48.65	27.53	17.52	30.88	142	192	P	H
			2483.56	46.01	-7.99	54	31.84	27.53	17.52	30.88	142	192	A	H
														H
														H
	*		2462	110.68	-	-	96.51	27.58	17.48	30.89	367	291	P	V
	*		2462	101.81	-	-	87.64	27.58	17.48	30.89	367	291	A	V
			2484	63.15	-10.85	74	48.98	27.53	17.52	30.88	367	291	P	V
			2483.96	46.13	-7.87	54	31.96	27.53	17.52	30.88	367	291	A	V
													V	
													V	



2.4GHz 2400~2483.5MHz

WIFI 802.11 ax HE40 Full (Band Edge @ 3m)

WIFI Ant. 0+1	Note	Frequency ( MHz )	Level ( dBμV/m )	Over Limit ( dB )	Limit Line ( dBμV/m )	Read Level ( dBμV )	Antenna Factor ( dB/m )	Path Loss ( dB )	Preamp Factor ( dB )	Ant Pos ( cm )	Table Pos ( deg )	Peak Avg. ( P/A )	Pol. ( H/V )
802.11ax HE40 Full CH 03 2422MHz		2389.22	60.96	-13.04	74	46.77	27.76	17.35	30.92	100	332	P	H
		2390	50.89	-3.11	54	36.7	27.76	17.35	30.92	100	332	A	H
	*	2422	107.94	-	-	93.77	27.66	17.41	30.9	100	332	P	H
	*	2422	97.43	-	-	83.26	27.66	17.41	30.9	100	332	A	H
		2484.79	56.64	-17.36	74	42.47	27.53	17.52	30.88	100	332	P	H
		2483.53	45.37	-8.63	54	31.2	27.53	17.52	30.88	100	332	A	H
		2390	58.6	-15.4	74	44.41	27.76	17.35	30.92	389	290	P	V
		2390	48.21	-5.79	54	34.02	27.76	17.35	30.92	389	290	A	V
	*	2422	105.72	-	-	91.55	27.66	17.41	30.9	389	290	P	V
	*	2422	96.79	-	-	82.62	27.66	17.41	30.9	389	290	A	V
		2493.7	55.69	-18.31	74	41.51	27.51	17.54	30.87	389	290	P	V
		2483.53	45.15	-8.85	54	30.98	27.53	17.52	30.88	389	290	A	V
802.11ax HE40 Full CH 09 2452MHz		2376.3	56.3	-17.7	74	42.06	27.84	17.32	30.92	100	334	P	H
		2389.9	45.4	-8.6	54	31.21	27.76	17.35	30.92	100	334	A	H
	*	2452	108.12	-	-	93.95	27.6	17.46	30.89	100	334	P	H
	*	2452	97.73	-	-	83.56	27.6	17.46	30.89	100	334	A	H
		2484.34	62.8	-11.2	74	48.63	27.53	17.52	30.88	100	334	P	H
		2483.53	51.21	-2.79	54	37.04	27.53	17.52	30.88	100	334	A	H
		2340.43	56.34	-17.66	74	42.01	28.02	17.25	30.94	378	299	P	V
		2333.29	45.12	-8.88	54	30.8	28.03	17.23	30.94	378	299	A	V
	*	2452	106.62	-	-	92.45	27.6	17.46	30.89	378	299	P	V
	*	2452	95.56	-	-	81.39	27.6	17.46	30.89	378	299	A	V
	2483.98	59.96	-14.04	74	45.79	27.53	17.52	30.88	378	299	P	V	
	2483.53	49.36	-4.64	54	35.19	27.53	17.52	30.88	378	299	A	V	
Remark	1. No other spurious found. 2. All results are PASS against Peak and Average limit line.												



2.4GHz 2400~2483.5MHz

WIFI 802.11ax HE40 Partial 242 (Band Edge @ 3m)

WIFI Ant. 0+1	Note	Frequency ( MHz )	Level ( dBμV/m )	Over Limit ( dB )	Limit Line ( dBμV/m )	Read Level ( dBμV )	Antenna Factor ( dB/m )	Path Loss ( dB )	Preamp Factor ( dB )	Ant Pos ( cm )	Table Pos ( deg )	Peak Avg. ( P/A )	Pol. ( H/V )
802.11ax HE40 Partial 242/61 CH 03 2422MHz		2387.44	68.87	-5.13	74	54.67	27.78	17.34	30.92	100	190	P	H
		2390	48.93	-5.07	54	34.74	27.76	17.35	30.92	100	190	A	H
	*	2422	110.16	-	-	95.99	27.66	17.41	30.9	100	190	P	H
	*	2422	100.16	-	-	85.99	27.66	17.41	30.9	100	190	A	H
		2484.4	58.8	-15.2	74	44.63	27.53	17.52	30.88	100	190	P	H
		2485.76	45.34	-8.66	54	31.17	27.53	17.52	30.88	100	190	A	H
		2387.92	65.89	-8.11	74	51.7	27.77	17.34	30.92	391	288	P	V
		2388.4	46.76	-7.24	54	32.57	27.77	17.34	30.92	391	288	A	V
	*	2422	110.32	-	-	96.15	27.66	17.41	30.9	391	288	P	V
	*	2422	100.29	-	-	86.12	27.66	17.41	30.9	391	288	A	V
		2484.16	55.95	-18.05	74	41.78	27.53	17.52	30.88	391	288	P	V
		2484.56	45.32	-8.68	54	31.15	27.53	17.52	30.88	391	288	A	V
802.11ax HE40 Partial 242/62 CH 09 2452MHz		2354	56.9	-17.1	74	42.57	27.98	17.28	30.93	145	194	P	H
		2353.36	45.58	-8.42	54	31.26	27.98	17.27	30.93	145	194	A	H
	*	2452	110.18	-	-	96.01	27.6	17.46	30.89	145	194	P	H
	*	2452	100.5	-	-	86.33	27.6	17.46	30.89	145	194	A	H
		2485.68	73.81	-0.19	74	59.64	27.53	17.52	30.88	145	194	P	H
		2484.48	51.93	-2.07	54	37.76	27.53	17.52	30.88	145	194	A	H
		2328.72	56.5	-17.5	74	42.17	28.04	17.23	30.94	376	292	P	V
		2321.04	45.53	-8.47	54	31.21	28.06	17.21	30.95	376	292	A	V
	*	2452	109.59	-	-	95.42	27.6	17.46	30.89	376	292	P	V
	*	2452	99.98	-	-	85.81	27.6	17.46	30.89	376	292	A	V
		2485.52	69.85	-4.15	74	55.68	27.53	17.52	30.88	376	292	P	V
		2483.52	49.03	-4.97	54	34.86	27.53	17.52	30.88	376	292	A	V



Emission below 1GHz

2.4GHz WIFI 802.11ax HE40 Partial RU242 (LF)

WIFI	Note	Frequency	Level	Over	Limit	Read	Antenna	Path	Preamp	Ant	Table	Peak	Pol.	
Ant.				Limit	Line	Level	Factor	Loss	Factor	Pos	Pos	Avg.		
0+1		( MHz )	( dBμV/m )	( dB )	( dBμV/m )	( dBμV )	( dB/m )	( dB )	( dB )	( cm )	( deg )	( P/A )	( H/V )	
2.4GHz 802.11ax HE40 Partial RU242 LF		32.91	20.64	-19.36	40	30.54	21.69	0.74	32.33	-	-	P	H	
		87.23	21.84	-18.16	40	38.43	14.53	1.27	32.39	-	-	A	H	
		174.53	33.16	-10.34	43.5	48.15	15.54	1.86	32.39	-	-	P	H	
		216.24	33.05	-12.95	46	48.43	14.92	2.09	32.39	-	-	A	H	
		729.37	39.85	-6.15	46	41.26	27.26	3.77	32.44	100	0	P	H	
		914.64	37.61	-8.39	46	36.12	28.87	4.35	31.73	-	-	A	H	
														H
														H
														H
														H
														H
														H
			30.97	20.62	-19.38	40	30.38	21.85	0.72	32.33	-	-	P	V
			80.44	23.4	-16.6	40	41	13.7	1.2	32.5	-	-	A	V
			187.14	27.16	-16.34	43.5	42.6	15	1.94	32.38	-	-	P	V
			216.24	26.2	-19.8	46	41.58	14.92	2.09	32.39	-	-	A	V
			509.18	25.45	-20.55	46	30.84	23.85	3.16	32.4	-	-	P	V
			721.61	31.94	-14.06	46	33.67	26.95	3.74	32.42	100	0	A	V
													V	
													V	
													V	
													V	
													V	
													V	
<b>Remark</b>	1. No other spurious found. 2. All results are PASS against limit line.													



**Note symbol**

*	<b>Fundamental Frequency</b> which can be ignored. However, the level of any unwanted emissions shall not exceed the level of the fundamental frequency.
!	Test result is <b>over limit</b> line.
P/A	<b>Peak</b> or <b>Average</b>
H/V	<b>Horizontal</b> or <b>Vertical</b>



A calculation example for radiated spurious emission is shown as below:

WIFI	Note	Frequency	Level	Over	Limit	Read	Antenna	Path	Preamp	Ant	Table	Peak	Pol.
Ant.				Limit	Line	Level	Factor	Loss	Factor	Pos	Pos	Avg.	
0+1		( MHz )	( dBμV/m )	( dB )	( dBμV/m )	( dBμV )	( dB/m )	( dB )	( dB )	( cm )	( deg )	( P/A )	( H/V )
802.11b		2390	55.45	-18.55	74	54.51	32.22	4.58	35.86	103	308	P	H
CH 01													
2412MHz		2390	43.54	-10.46	54	42.6	32.22	4.58	35.86	103	308	A	H

1. Path Loss(dB) = Cable loss(dB) + Filter loss(dB) + Attenuator loss(dB)
2. Level(dBμV/m) =  
Antenna Factor(dB/m) + Path Loss(dB) + Read Level(dBμV) - Preamp Factor(dB)
3. Over Limit(dB) = Level(dBμV/m) – Limit Line(dBμV/m)

**For Peak Limit @ 2390MHz:**

1. Level(dBμV/m)  
= Antenna Factor(dB/m) + Path Loss(dB) + Read Level(dBμV) - Preamp Factor(dB)  
= 32.22(dB/m) + 4.58(dB) + 54.51(dBμV) – 35.86 (dB)  
= 55.45 (dBμV/m)
2. Over Limit(dB)  
= Level(dBμV/m) – Limit Line(dBμV/m)  
= 55.45(dBμV/m) – 74(dBμV/m)  
= -18.55(dB)

**For Average Limit @ 2390MHz:**

1. Level(dBμV/m)  
= Antenna Factor(dB/m) + Path Loss(dB) + Read Level(dBμV) - Preamp Factor(dB)  
= 32.22(dB/m) + 4.58(dB) + 42.6(dBμV) – 35.86 (dB)  
= 43.54 (dBμV/m)
2. Over Limit(dB)  
= Level(dBμV/m) – Limit Line(dBμV/m)  
= 43.54(dBμV/m) – 54(dBμV/m)  
= -10.46(dB)

**Both peak and average measured complies with the limit line, so test result is “PASS”.**



### Appendix C. Radiated Spurious Emission Plots

Test Engineer :	Leo Lee, Mancy Chou and Bigshow Wang	Temperature :	22.3~23.1°C
		Relative Humidity :	48~55%

#### Note symbol

-L	Low channel location
-R	High channel location

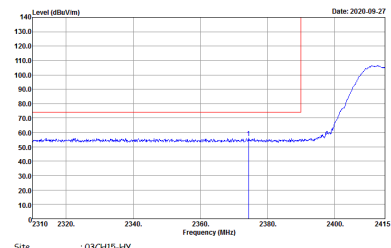
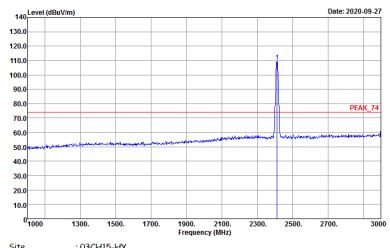
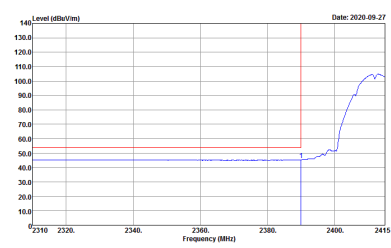
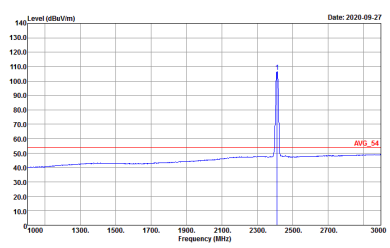

**2.4GHz 2400~2483.5MHz**  
**WIFI 802.11b (Band Edge @ 3m)**

WIFI	2.4GHz 2400~2483.5MHz Band Edge @ 3m	
ANT	802.11b CH01 2412MHz	
0+1	Horizontal	Fundamental
<b>Peak</b>	 <p>Site : 03CH15-HY            Condition : PEAK_BE_74 3m 91200_15_1620 HORIZONTAL            RBW:1000.000KHz VBW:3000.000KHz SWT:Auto            Detector : Peak            Project : 090125</p>	 <p>Site : 03CH15-HY            Condition : PEAK_74 3m 91200_15_1620 HORIZONTAL            RBW:1000.000KHz VBW:3000.000KHz SWT:Auto            Detector : Peak            Project : 090125</p>
<b>Avg.</b>	 <p>Site : 03CH15-HY            Condition : AV6_BE_54 3m 91200_15_1620 HORIZONTAL            RBW:1000.000KHz VBW:0.010KHz SWT:Auto            Detector : Peak            Project : 090125</p>	 <p>Site : 03CH15-HY            Condition : AV6_54 3m 91200_15_1620 HORIZONTAL            RBW:1000.000KHz VBW:0.010KHz SWT:Auto            Detector : Peak            Project : 090125</p>



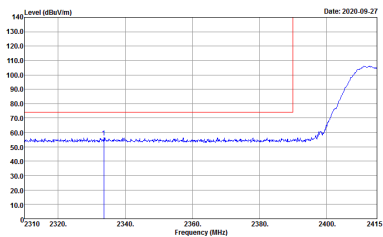
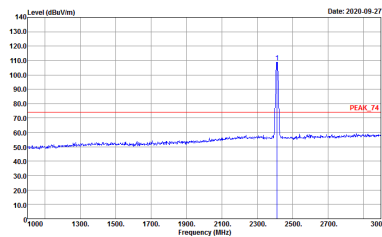
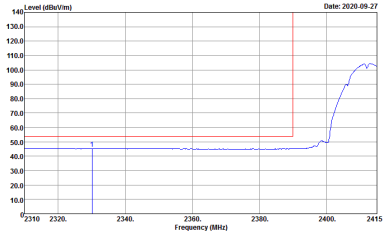
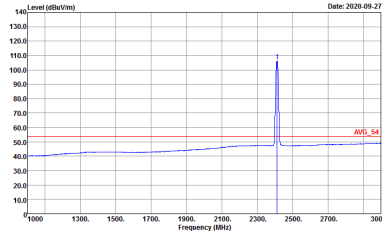

WIFI	2.4GHz 2400~2483.5MHz Band Edge @ 3m	
ANT	802.11b CH01 2412MHz	
0+1	Vertical	Fundamental
Peak	 <p>Date: 2020-09-27</p> <p>Site : 03CH15-HY            Condition : PEAK_BE_74 3m 91200_15_1620 VERTICAL            : RBW:1000.000KHz VBW:3000.000KHz SWT:Auto            Detector : Peak            Project : 090125</p>	 <p>Date: 2020-09-27</p> <p>Site : 03CH15-HY            Condition : PEAK_74 3m 91200_15_1620 VERTICAL            : RBW:1000.000KHz VBW:3000.000KHz SWT:Auto            Detector : Peak            Project : 090125</p>
Avg.	 <p>Date: 2020-09-27</p> <p>Site : 03CH15-HY            Condition : AVG_BE_54 3m 91200_15_1620 VERTICAL            : RBW:1000.000KHz VBW:3000.000KHz SWT:Auto            Detector : Peak            Project : 090125</p>	 <p>Date: 2020-09-27</p> <p>Site : 03CH15-HY            Condition : AVG_54 3m 91200_15_1620 VERTICAL            : RBW:1000.000KHz VBW:3000.000KHz SWT:Auto            Detector : Peak            Project : 090125</p>

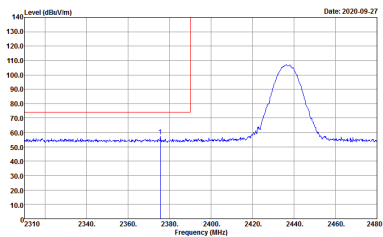
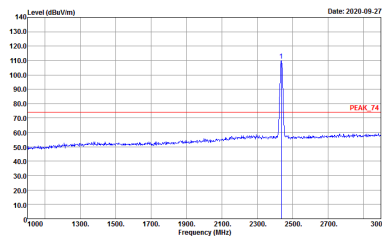
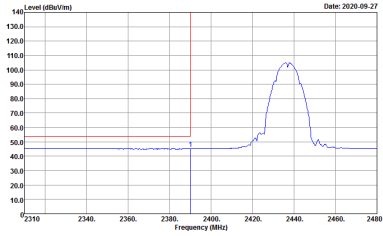
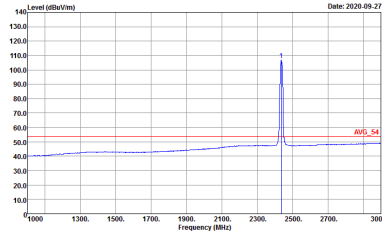

WIFI	2.4GHz 2400~2483.5MHz Band Edge @ 3m	
ANT	802.11b CH06 2437MHz - L	
0+1	Horizontal	Fundamental
Peak	 <p>Date: 2020-09-27</p> <p>Site : 03CH15-HY            Condition : PEAK_BE_74 3m 91200_15_1620 HORIZONTAL            : RBW:1000.000KHz VBW:3000.000KHz SWT:Auto            Detector : Peak            Project : 090125</p>	 <p>Date: 2020-09-27</p> <p>Site : 03CH15-HY            Condition : PEAK_74 3m 91200_15_1620 HORIZONTAL            : RBW:1000.000KHz VBW:3000.000KHz SWT:Auto            Detector : Peak            Project : 090125</p>
Avg.	 <p>Date: 2020-09-27</p> <p>Site : 03CH15-HY            Condition : AVG_BE_54 3m 91200_15_1620 HORIZONTAL            : RBW:1000.000KHz VBW:0.010KHz SWT:Auto            Detector : Peak            Project : 090125</p>	 <p>Date: 2020-09-27</p> <p>Site : 03CH15-HY            Condition : AVG_54 3m 91200_15_1620 HORIZONTAL            : RBW:1000.000KHz VBW:0.010KHz SWT:Auto            Detector : Peak            Project : 090125</p>

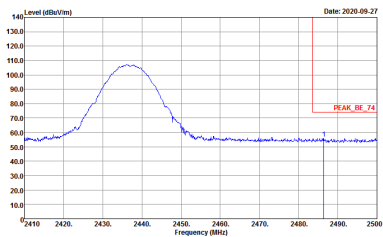
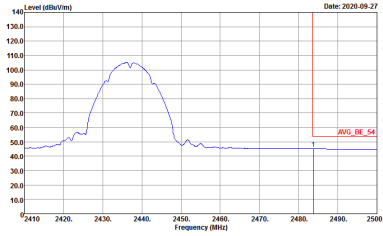

WIFI	2.4GHz 2400~2483.5MHz Band Edge @ 3m	
ANT	802.11b CH06 2437MHz - R	
0+1	Horizontal	Fundamental
<p><b>Peak</b></p>	 <p>Site : 03CH15-HY            Condition : PEAK_BE_74 3m 91200_15_1620 HORIZONTAL            Detector : Peak            Project : 090125</p>	<p>Left blank</p>
<p><b>Avg.</b></p>	 <p>Site : 03CH15-HY            Condition : AVG_BE_54 3m 91200_15_1620 HORIZONTAL            Detector : Peak            Project : 090125</p>	<p>Left blank</p>

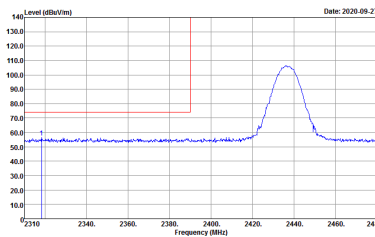
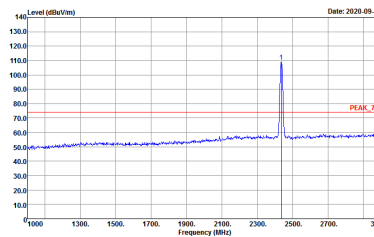
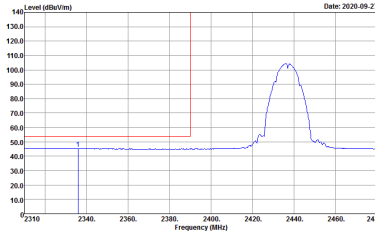
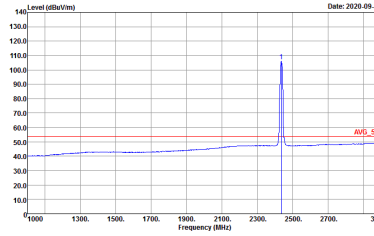

WIFI	2.4GHz 2400~2483.5MHz Band Edge @ 3m	
ANT	802.11b CH06 2437MHz - L	
0+1	Vertical	Fundamental
Peak	 <p>Date: 2020-09-27</p> <p>Site : 03CH15-HY            Condition : PEAK_BE_74 3m 91200_15_1620 VERTICAL            : RBW:1000.000KHz VBW:3000.000KHz SWT:Auto            Detector : Peak            Project : 090125</p>	 <p>Date: 2020-09-27</p> <p>Site : 03CH15-HY            Condition : PEAK_74 3m 91200_15_1620 VERTICAL            : RBW:1000.000KHz VBW:3000.000KHz SWT:Auto            Detector : Peak            Project : 090125</p>
Avg.	 <p>Date: 2020-09-27</p> <p>Site : 03CH15-HY            Condition : AVG_BE_54 3m 91200_15_1620 VERTICAL            : RBW:1000.000KHz VBW:0.010KHz SWT:Auto            Detector : Peak            Project : 090125</p>	 <p>Date: 2020-09-27</p> <p>Site : 03CH15-HY            Condition : AVG_54 3m 91200_15_1620 VERTICAL            : RBW:1000.000KHz VBW:0.010KHz SWT:Auto            Detector : Peak            Project : 090125</p>

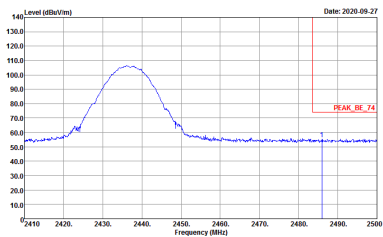
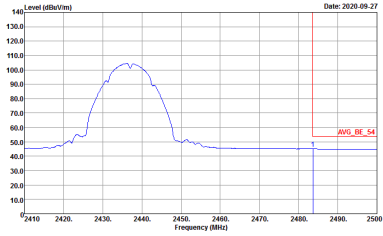

WIFI	2.4GHz 2400~2483.5MHz Band Edge @ 3m	
ANT	802.11b CH06 2437MHz - R	
0+1	Vertical	Fundamental
<p><b>Peak</b></p>	 <p>Site : 03CH15-HY            Condition : PEAK_BE_74 3m 91200_15_1620 VERTICAL            Detector : Peak            Project : 090125</p>	<p>Left blank</p>
<p><b>Avg.</b></p>	 <p>Site : 03CH15-HY            Condition : AVG_BE_54 3m 91200_15_1620 VERTICAL            Detector : Peak            Project : 090125</p>	<p>Left blank</p>

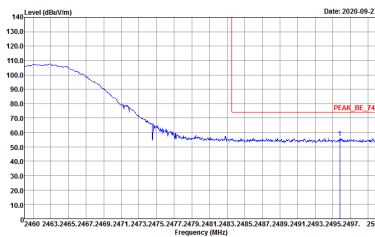
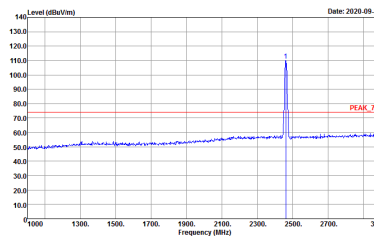
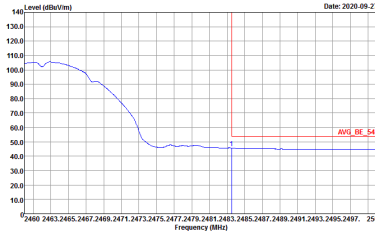
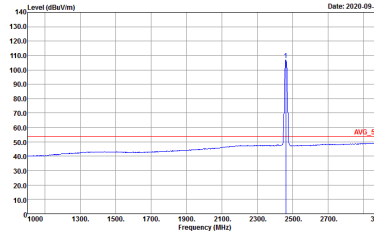

WIFI	2.4GHz 2400~2483.5MHz Band Edge @ 3m	
ANT	802.11b CH11 2462MHz	
0+1	Horizontal	Fundamental
Peak	 <p>Date: 2020-09-27</p> <p>Site : 03CH15-HY            Condition : PEAK_BE_74 3m 91200_15_1620 HORIZONTAL            : RBW:1000.000KHz VBW:3000.000KHz SWT:Auto            Detector : Peak            Project : 090125</p>	 <p>Date: 2020-09-27</p> <p>Site : 03CH15-HY            Condition : PEAK_74 3m 91200_15_1620 HORIZONTAL            : RBW:1000.000KHz VBW:3000.000KHz SWT:Auto            Detector : Peak            Project : 090125</p>
Avg.	 <p>Date: 2020-09-27</p> <p>Site : 03CH15-HY            Condition : AVG_BE_54 3m 91200_15_1620 HORIZONTAL            : RBW:1000.000KHz VBW:0.010KHz SWT:Auto            Detector : Peak            Project : 090125</p>	 <p>Date: 2020-09-27</p> <p>Site : 03CH15-HY            Condition : AVG_54 3m 91200_15_1620 HORIZONTAL            : RBW:1000.000KHz VBW:0.010KHz SWT:Auto            Detector : Peak            Project : 090125</p>

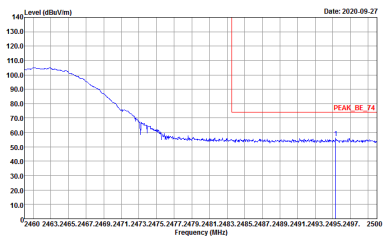
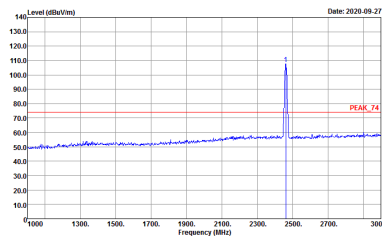
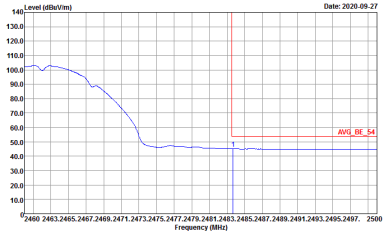
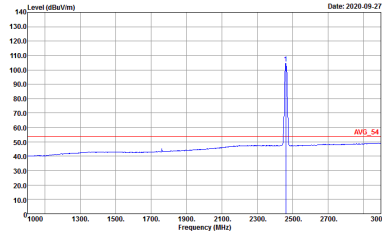

WIFI	2.4GHz 2400~2483.5MHz Band Edge @ 3m	
ANT	802.11b CH11 2462MHz	
0+1	Vertical	Fundamental
<p><b>Peak</b></p>	 <p>Date: 2020-09-27</p> <p>Site : 03CH15-HY            Condition : PEAK_BE_74 3m 91200_15_1620 VERTICAL            : RBW:1000.000KHz VBW:3000.000KHz SWT:Auto            Detector : Peak            Project : 090125</p>	 <p>Date: 2020-09-27</p> <p>Site : 03CH15-HY            Condition : PEAK_74 3m 91200_15_1620 VERTICAL            : RBW:1000.000KHz VBW:3000.000KHz SWT:Auto            Detector : Peak            Project : 090125</p>
<p><b>Avg.</b></p>	 <p>Date: 2020-09-27</p> <p>Site : 03CH15-HY            Condition : AVG_BE_54 3m 91200_15_1620 VERTICAL            : RBW:1000.000KHz VBW:0.010KHz SWT:Auto            Detector : Peak            Project : 090125</p>	 <p>Date: 2020-09-27</p> <p>Site : 03CH15-HY            Condition : AVG_54 3m 91200_15_1620 VERTICAL            : RBW:1000.000KHz VBW:0.010KHz SWT:Auto            Detector : Peak            Project : 090125</p>



2.4GHz 2400~2483.5MHz  
WIFI 802.11g (Band Edge @ 3m)

WIFI	2.4GHz 2400~2483.5MHz Band Edge @ 3m	
ANT	802.11g CH01 2412MHz	
0+1	Horizontal	Fundamental
Peak	<p>Site : 03CH15-HY Condition : PEAK_BE_74 3m 91200_15_1620 HORIZONTAL Detector : Peak Project : 090125</p>	<p>Site : 03CH15-HY Condition : PEAK_74 3m 91200_15_1620 HORIZONTAL Detector : Peak Project : 090125</p>
Avg.	<p>Site : 03CH15-HY Condition : AV6_BE_54 3m 91200_15_1620 HORIZONTAL Detector : Peak Project : 090125</p>	<p>Site : 03CH15-HY Condition : AV6_54 3m 91200_15_1620 HORIZONTAL Detector : Peak Project : 090125</p>



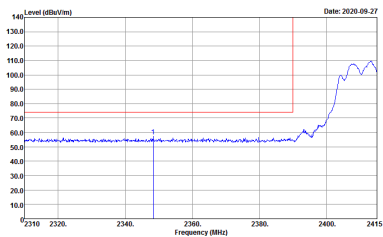
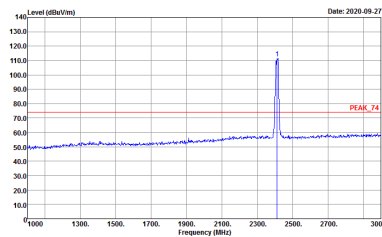
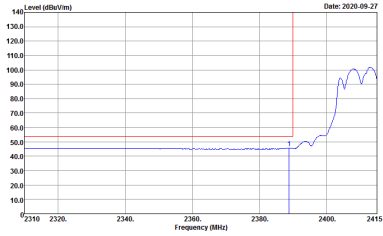
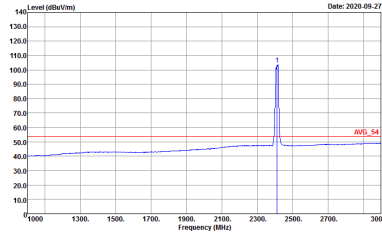

WIFI	2.4GHz 2400~2483.5MHz Band Edge @ 3m	
ANT	802.11g CH01 2412MHz	
0+1	Vertical	Fundamental
Peak	 <p>Date: 2020-09-27</p> <p>Site : 03CH15-HY            Condition : PEAK_BE_74 3m 91200_15_1620 VERTICAL            : RBW:1000.000KHz VBW:3000.000KHz SWT:Auto            Detector : Peak            Project : 090125</p>	 <p>Date: 2020-09-27</p> <p>Site : 03CH15-HY            Condition : PEAK_74 3m 91200_15_1620 VERTICAL            : RBW:1000.000KHz VBW:3000.000KHz SWT:Auto            Detector : Peak            Project : 090125</p>
Avg.	 <p>Date: 2020-09-27</p> <p>Site : 03CH15-HY            Condition : AVG_BE_54 3m 91200_15_1620 VERTICAL            : RBW:1000.000KHz VBW:3000.000KHz SWT:Auto            Detector : Peak            Project : 090125</p>	 <p>Date: 2020-09-27</p> <p>Site : 03CH15-HY            Condition : AVG_54 3m 91200_15_1620 VERTICAL            : RBW:1000.000KHz VBW:3000.000KHz SWT:Auto            Detector : Peak            Project : 090125</p>

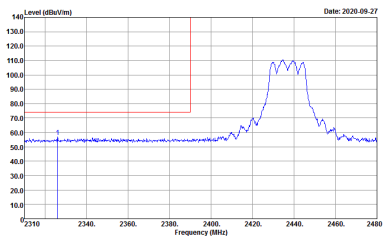
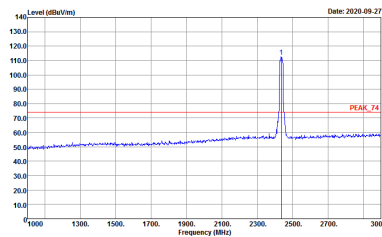
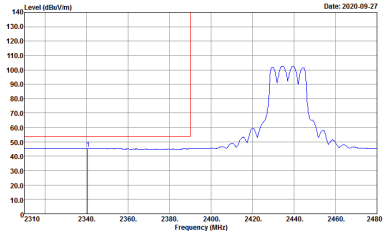
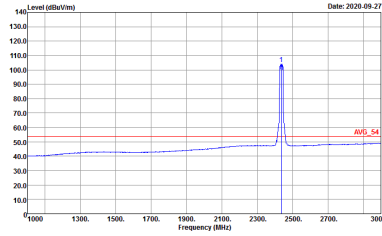

WIFI	2.4GHz 2400~2483.5MHz Band Edge @ 3m	
ANT	802.11g CH06 2437MHz - L	
0+1	Horizontal	Fundamental
Peak	 <p>Date: 2020-09-27</p> <p>Site : 03CH15-HY            Condition : PEAK_BE_74 3m 91200_15_1620 HORIZONTAL            : RBW:1000.000KHz VBW:3000.000KHz SWT:Auto            Detector : Peak            Project : 090125</p>	 <p>Date: 2020-09-27</p> <p>Site : 03CH15-HY            Condition : PEAK_74 3m 91200_15_1620 HORIZONTAL            : RBW:1000.000KHz VBW:3000.000KHz SWT:Auto            Detector : Peak            Project : 090125</p>
Avg.	 <p>Date: 2020-09-27</p> <p>Site : 03CH15-HY            Condition : AVG_BE_54 3m 91200_15_1620 HORIZONTAL            : RBW:1000.000KHz VBW:0.010KHz SWT:Auto            Detector : Peak            Project : 090125</p>	 <p>Date: 2020-09-27</p> <p>Site : 03CH15-HY            Condition : AVG_54 3m 91200_15_1620 HORIZONTAL            : RBW:1000.000KHz VBW:0.010KHz SWT:Auto            Detector : Peak            Project : 090125</p>

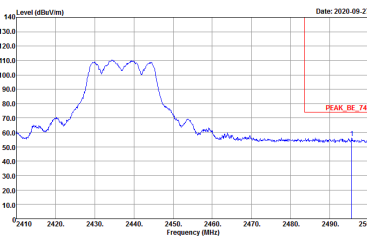
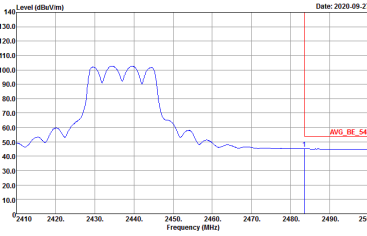

WIFI	2.4GHz 2400~2483.5MHz Band Edge @ 3m	
ANT	802.11g CH06 2437MHz - R	
0+1	Horizontal	Fundamental
<p><b>Peak</b></p>	 <p>Site : 03CH15-HY            Condition : PEAK_BE_74 3m 91200_15_1620 HORIZONTAL            Detector : Peak            Project : 090125</p>	<p>Left blank</p>
<p><b>Avg.</b></p>	 <p>Site : 03CH15-HY            Condition : AVG_BE_54 3m 91200_15_1620 HORIZONTAL            Detector : Peak            Project : 090125</p>	<p>Left blank</p>

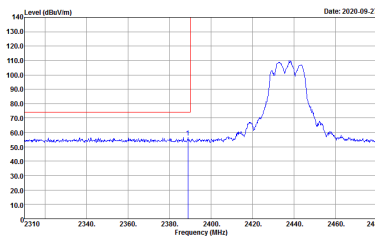
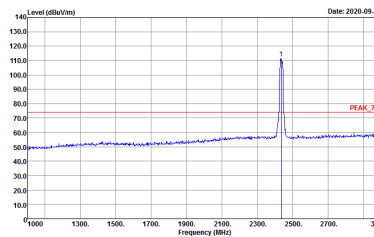
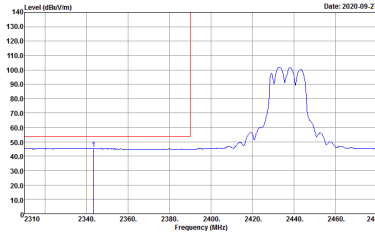
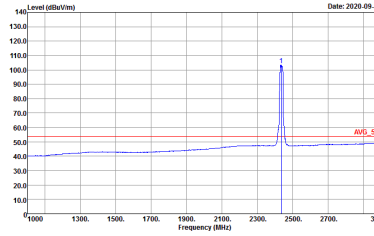

WIFI	2.4GHz 2400~2483.5MHz Band Edge @ 3m	
ANT	802.11g CH06 2437MHz - L	
0+1	Vertical	Fundamental
Peak	 <p>Date: 2020-09-27</p> <p>Site : 03CH15-HY            Condition : PEAK_BE_74 3m 91200_15_1620 VERTICAL            : RBW:1000.000KHz VBW:3000.000KHz SWT:Auto            Detector : Peak            Project : 090125</p>	 <p>Date: 2020-09-27</p> <p>Site : 03CH15-HY            Condition : PEAK_74 3m 91200_15_1620 VERTICAL            : RBW:1000.000KHz VBW:3000.000KHz SWT:Auto            Detector : Peak            Project : 090125</p>
Avg.	 <p>Date: 2020-09-27</p> <p>Site : 03CH15-HY            Condition : AVG_BE_54 3m 91200_15_1620 VERTICAL            : RBW:1000.000KHz VBW:0.010KHz SWT:Auto            Detector : Peak            Project : 090125</p>	 <p>Date: 2020-09-27</p> <p>Site : 03CH15-HY            Condition : AVG_54 3m 91200_15_1620 VERTICAL            : RBW:1000.000KHz VBW:0.010KHz SWT:Auto            Detector : Peak            Project : 090125</p>

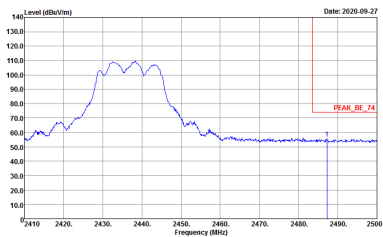
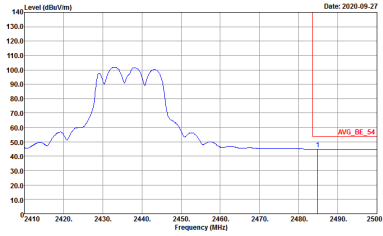

WIFI	2.4GHz 2400~2483.5MHz Band Edge @ 3m	
ANT	802.11g CH06 2437MHz - R	
0+1	Vertical	Fundamental
<p><b>Peak</b></p>	 <p>Site : 03CH15-HY            Condition : PEAK_BE_74 3m 91200_15_1620 VERTICAL            Detector : Peak            Project : 090125</p>	<p>Left Blank</p>
<p><b>Avg.</b></p>	 <p>Site : 03CH15-HY            Condition : AVG_BE_54 3m 91200_15_1620 VERTICAL            Detector : Peak            Project : 090125</p>	<p>Left Blank</p>

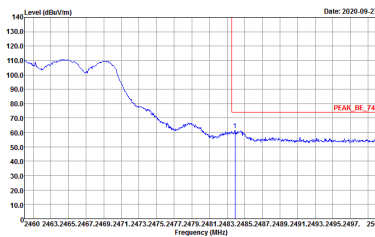
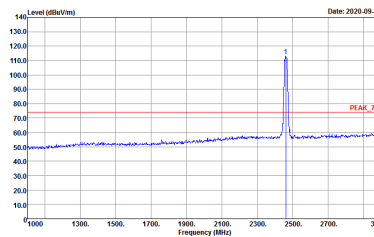
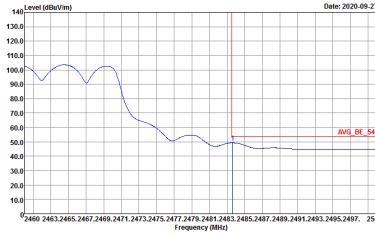
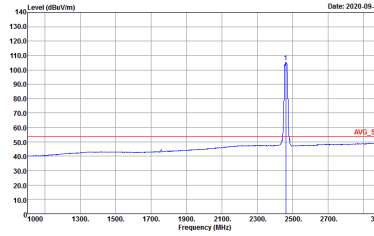

WIFI	2.4GHz 2400~2483.5MHz Band Edge @ 3m	
ANT	802.11g CH11 2462MHz	
0+1	Horizontal	Fundamental
<p><b>Peak</b></p>	 <p>Date: 2020-09-27</p> <p>Site : 03CH15-HY            Condition : PEAK_BE_74 3m 91200_15_1620 HORIZONTAL            : RBW:1000.000kHz VBW:3000.000kHz SWT:Auto            Detector : Peak            Project : 090125</p>	 <p>Date: 2020-09-27</p> <p>Site : 03CH15-HY            Condition : PEAK_74 3m 91200_15_1620 HORIZONTAL            : RBW:1000.000kHz VBW:3000.000kHz SWT:Auto            Detector : Peak            Project : 090125</p>
<p><b>Avg.</b></p>	 <p>Date: 2020-09-27</p> <p>Site : 03CH15-HY            Condition : AVG_BE_54 3m 91200_15_1620 HORIZONTAL            : RBW:1000.000kHz VBW:0.010kHz SWT:Auto            Detector : Peak            Project : 090125</p>	 <p>Date: 2020-09-27</p> <p>Site : 03CH15-HY            Condition : AVG_54 3m 91200_15_1620 HORIZONTAL            : RBW:1000.000kHz VBW:0.010kHz SWT:Auto            Detector : Peak            Project : 090125</p>

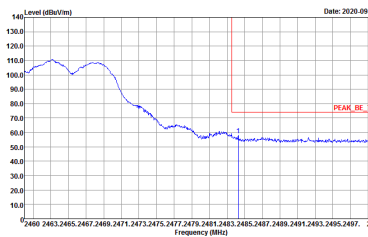
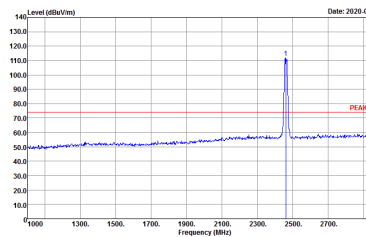
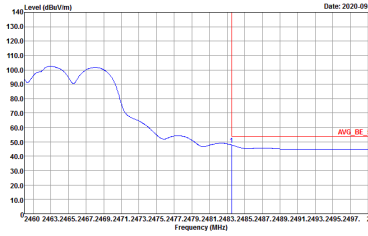
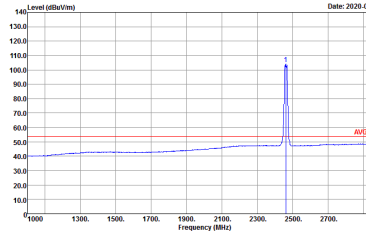

WIFI	2.4GHz 2400~2483.5MHz Band Edge @ 3m	
ANT	802.11g CH11 2462MHz	
0+1	Vertical	Fundamental
Peak	 <p>Date: 2020-09-27</p> <p>Site : 03CH15-HY            Condition : PEAK_BE_74 3m 91200_15_1620 VERTICAL            : RBW:1000.000KHz VBW:3000.000KHz SWT:Auto            Detector : Peak            Project : 090125</p>	 <p>Date: 2020-09-27</p> <p>Site : 03CH15-HY            Condition : PEAK_74 3m 91200_15_1620 VERTICAL            : RBW:1000.000KHz VBW:3000.000KHz SWT:Auto            Detector : Peak            Project : 090125</p>
Avg.	 <p>Date: 2020-09-27</p> <p>Site : 03CH15-HY            Condition : AVG_BE_54 3m 91200_15_1620 VERTICAL            : RBW:1000.000KHz VBW:0.010KHz SWT:Auto            Detector : Peak            Project : 090125</p>	 <p>Date: 2020-09-27</p> <p>Site : 03CH15-HY            Condition : AVG_54 3m 91200_15_1620 VERTICAL            : RBW:1000.000KHz VBW:0.010KHz SWT:Auto            Detector : Peak            Project : 090125</p>



2.4GHz 2400~2483.5MHz

WIFI 802.11ax HE20 Full (Band Edge @ 3m)

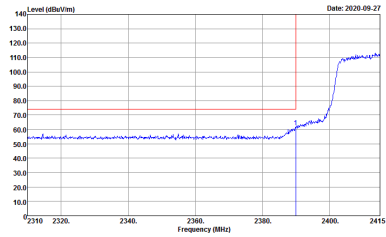
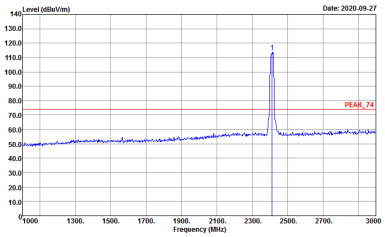
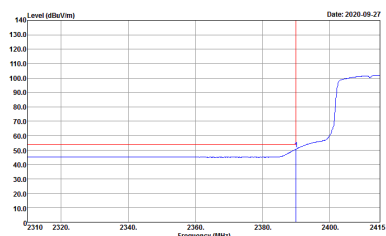
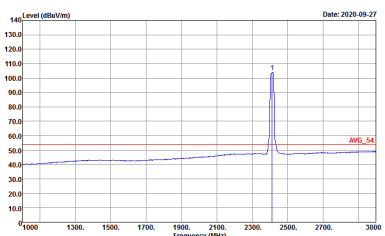
WIFI	2.4GHz 2400~2483.5MHz Band Edge @ 3m	
ANT	802.11ax HE20 Full CH01 2412MHz	
0+1	Horizontal	Fundamental
<b>Peak</b>	 <p>Site : 03CH15-HY            Condition : PEAK_BE_74 3m 91200_15_1620 HORIZONTAL            RBW:1000.000KHz VBW:3000.000KHz SWT:Auto            Detector : Peak            Project : 090125</p>	 <p>Site : 03CH15-HY            Condition : PEAK_74 3m 91200_15_1620 HORIZONTAL            RBW:1000.000KHz VBW:3000.000KHz SWT:Auto            Detector : Peak            Project : 090125</p>
<b>Avg.</b>	 <p>Site : 03CH15-HY            Condition : AV6_BE_54 3m 91200_15_1620 HORIZONTAL            RBW:1000.000KHz VBW:0.010KHz SWT:Auto            Detector : Peak            Project : 090125</p>	 <p>Site : 03CH15-HY            Condition : AV6_54 3m 91200_15_1620 HORIZONTAL            RBW:1000.000KHz VBW:0.010KHz SWT:Auto            Detector : Peak            Project : 090125</p>



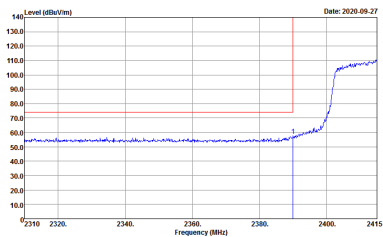
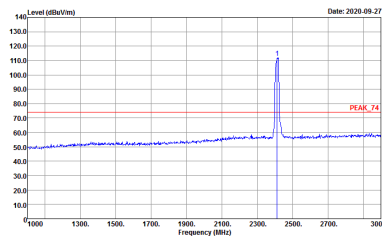
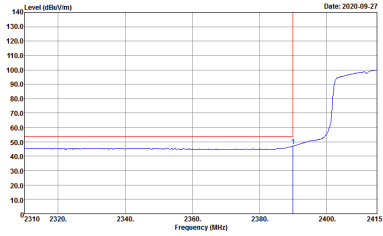

WIFI	2.4GHz 2400~2483.5MHz Band Edge @ 3m	
ANT	802.11ax HE20 Full CH01 2412MHz	
0+1	Vertical	Fundamental
Peak	 <p>Date: 2020-09-27</p> <p>Site : 03CH15-HY            Condition : PEAK_BE_74 3m 91200_15_1620 VERTICAL            : RBW:1000.000KHz VBW:3000.000KHz SWT:Auto            Detector : Peak            Project : 090125</p>	 <p>Date: 2020-09-27</p> <p>Site : 03CH15-HY            Condition : PEAK_74 3m 91200_15_1620 VERTICAL            : RBW:1000.000KHz VBW:3000.000KHz SWT:Auto            Detector : Peak            Project : 090125</p>
Avg.	 <p>Date: 2020-09-27</p> <p>Site : 03CH15-HY            Condition : AVG_BE_54 3m 91200_15_1620 VERTICAL            : RBW:1000.000KHz VBW:0.010KHz SWT:Auto            Detector : Peak            Project : 090125</p>	 <p>Date: 2020-09-27</p> <p>Site : 03CH15-HY            Condition : AVG_54 3m 91200_15_1620 VERTICAL            : RBW:1000.000KHz VBW:0.010KHz SWT:Auto            Detector : Peak            Project : 090125</p>

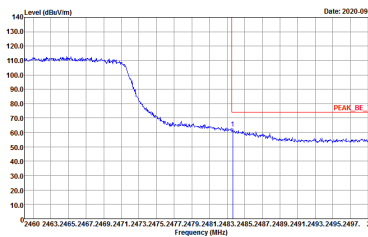
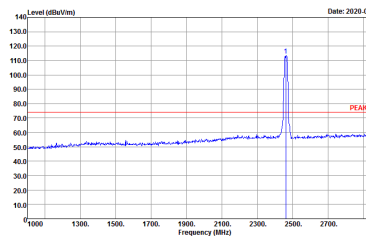
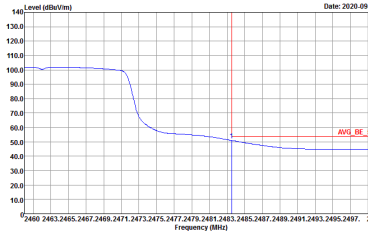
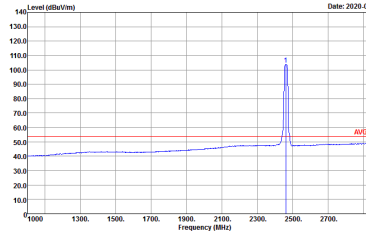

WIFI	2.4GHz 2400~2483.5MHz Band Edge @ 3m	
ANT	802.11ax HE20 Full CH11 2462MHz	
0+1	Horizontal	Fundamental
Peak	 <p>Date: 2020-09-27</p> <p>Site : 03CH15-HY            Condition : PEAK_BE_74 3m 91200_15_1620 HORIZONTAL            : RBW:1000.000KHz VBW:3000.000KHz SWT:Auto            Detector : Peak            Project : 090125</p>	 <p>Date: 2020-09-27</p> <p>Site : 03CH15-HY            Condition : PEAK_74 3m 91200_15_1620 HORIZONTAL            : RBW:1000.000KHz VBW:3000.000KHz SWT:Auto            Detector : Peak            Project : 090125</p>
Avg.	 <p>Date: 2020-09-27</p> <p>Site : 03CH15-HY            Condition : AVG_BE_54 3m 91200_15_1620 HORIZONTAL            : RBW:1000.000KHz VBW:0.010KHz SWT:Auto            Detector : Peak            Project : 090125</p>	 <p>Date: 2020-09-27</p> <p>Site : 03CH15-HY            Condition : AVG_54 3m 91200_15_1620 HORIZONTAL            : RBW:1000.000KHz VBW:0.010KHz SWT:Auto            Detector : Peak            Project : 090125</p>

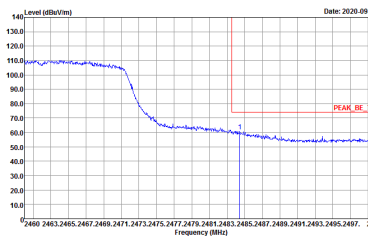
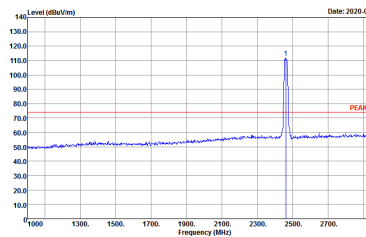
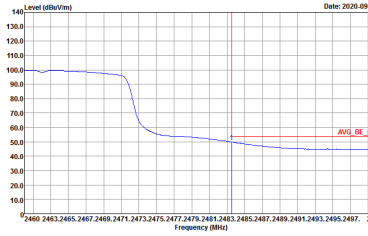
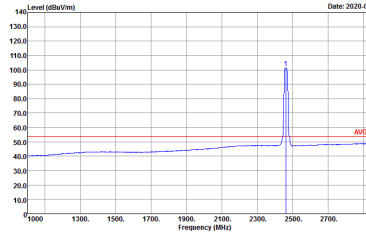

WIFI	2.4GHz 2400~2483.5MHz Band Edge @ 3m	
ANT	802.11ax HE20 Full CH11 2462MHz	
0+1	Vertical	Fundamental
Peak	 <p>Date: 2020-09-27</p> <p>Site : 03CH15-HY            Condition : PEAK_BE_74 3m 91200_15_1620 VERTICAL            : RBW:1000.000KHz VBW:3000.000KHz SWT:Auto            Detector : Peak            Project : 090125</p>	 <p>Date: 2020-09-27</p> <p>Site : 03CH15-HY            Condition : PEAK_74 3m 91200_15_1620 VERTICAL            : RBW:1000.000KHz VBW:3000.000KHz SWT:Auto            Detector : Peak            Project : 090125</p>
Avg.	 <p>Date: 2020-09-27</p> <p>Site : 03CH15-HY            Condition : AVG_BE_54 3m 91200_15_1620 VERTICAL            : RBW:1000.000KHz VBW:0.010KHz SWT:Auto            Detector : Peak            Project : 090125</p>	 <p>Date: 2020-09-27</p> <p>Site : 03CH15-HY            Condition : AVG_54 3m 91200_15_1620 VERTICAL            : RBW:1000.000KHz VBW:0.010KHz SWT:Auto            Detector : Peak            Project : 090125</p>



2.4GHz 2400~2483.5MHz

WIFI 802.11ax HE20 Partial 106 (Band Edge @ 3m)

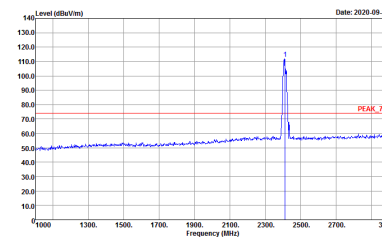
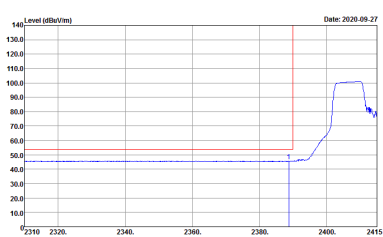
WIFI	2.4GHz 2400~2483.5MHz Band Edge @ 3m	
ANT	802.11ax HE20 Partial 106/53 CH01 2412MHz	
0+1	Horizontal	Fundamental
<b>Peak</b>	 <p>Date: 2020-09-27</p> <p>Site : 03CH15-HY            Condition : PEAK_BE_74 3m 91200_15_1620 HORIZONTAL            RBW:1000.000KHz VBW:3000.000KHz SWT:Auto            Detector : Peak            Project : 090125</p>	 <p>Date: 2020-09-27</p> <p>Site : 03CH15-HY            Condition : PEAK_74 3m 91200_15_1620 HORIZONTAL            RBW:1000.000KHz VBW:3000.000KHz SWT:Auto            Detector : Peak            Project : 090125</p>
<b>Avg.</b>	 <p>Date: 2020-09-27</p> <p>Site : 03CH15-HY            Condition : AVG_BE_54 3m 91200_15_1620 HORIZONTAL            RBW:1000.000KHz VBW:0.300KHz SWT:Auto            Detector : Peak            Project : 090125</p>	 <p>Date: 2020-09-27</p> <p>Site : 03CH15-HY            Condition : AVG_54 3m 91200_15_1620 HORIZONTAL            RBW:1000.000KHz VBW:0.300KHz SWT:Auto            Detector : Peak            Project : 090125</p>

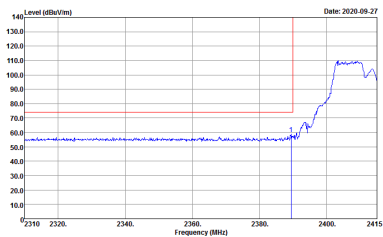
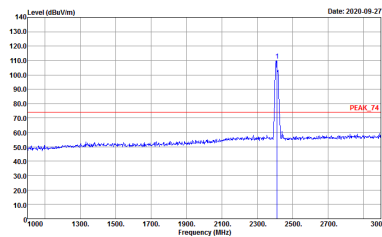
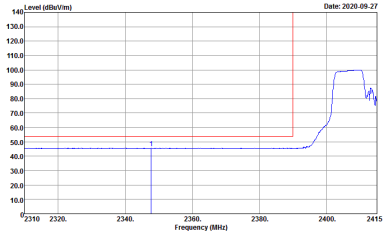

WIFI	2.4GHz 2400~2483.5MHz Band Edge @ 3m	
ANT	802.11ax HE20 Partial 106/53 CH01 2412MHz	
0+1	Vertical	Fundamental
Peak	 <p>Date: 2020-09-27</p> <p>Site : 03CH15-HY            Condition : PEAK_BE_74 3m 91200_15_1620 VERTICAL            : RBW:1000.000KHz VBW:3000.000KHz SWT:Auto            Detector : Peak            Project : 090125</p>	 <p>Date: 2020-09-27</p> <p>Site : 03CH15-HY            Condition : PEAK_74 3m 91200_15_1620 VERTICAL            : RBW:1000.000KHz VBW:3000.000KHz SWT:Auto            Detector : Peak            Project : 090125</p>
Avg.	 <p>Date: 2020-09-27</p> <p>Site : 03CH15-HY            Condition : AVG_BE_54 3m 91200_15_1620 VERTICAL            : RBW:1000.000KHz VBW:3000.000KHz SWT:Auto            Detector : Peak            Project : 090125</p>	 <p>Date: 2020-09-27</p> <p>Site : 03CH15-HY            Condition : AVG_54 3m 91200_15_1620 VERTICAL            : RBW:1000.000KHz VBW:3000.000KHz SWT:Auto            Detector : Peak            Project : 090125</p>

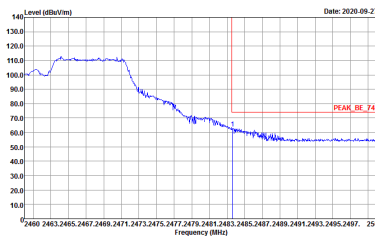
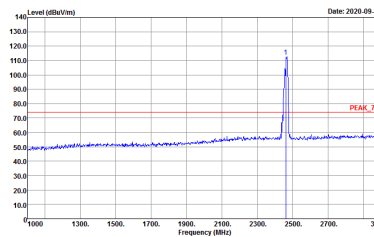
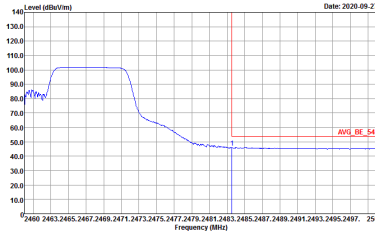
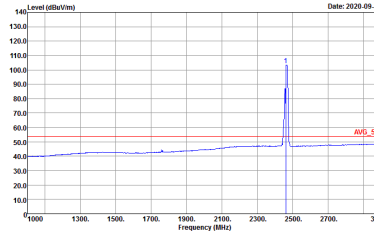

WIFI	2.4GHz 2400~2483.5MHz Band Edge @ 3m	
ANT	802.11ax HE20 Partial 106/54 CH11 2462MHz	
0+1	Horizontal	Fundamental
Peak	 <p>Site : 03CH15-HY          Condition : PEAK_BE_74 3m 91200_15_1620 HORIZONTAL          Detector : Peak          Project : 090125</p>	 <p>Site : 03CH15-HY          Condition : PEAK_74 3m 91200_15_1620 HORIZONTAL          Detector : Peak          Project : 090125</p>
Avg.	 <p>Site : 03CH15-HY          Condition : AVG_BE_54 3m 91200_15_1620 HORIZONTAL          Detector : Peak          Project : 090125</p>	 <p>Site : 03CH15-HY          Condition : AVG_54 3m 91200_15_1620 HORIZONTAL          Detector : Peak          Project : 090125</p>

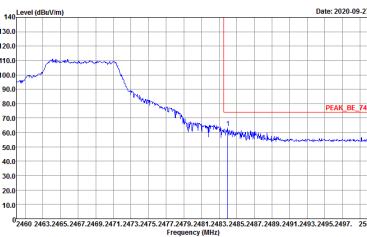
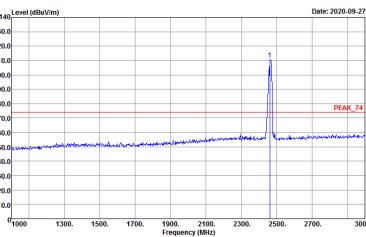
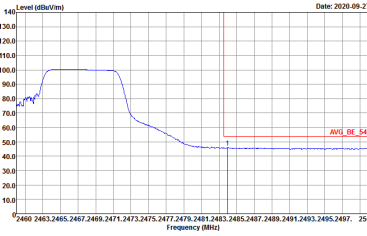
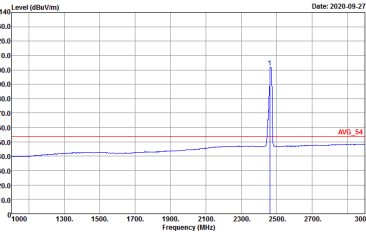

WIFI	2.4GHz 2400~2483.5MHz Band Edge @ 3m	
ANT	802.11ax HE20 Partial 106/54 CH11 2462MHz	
0+1	Vertical	Fundamental
Peak	 <p>Site : 03CH15-HY          Condition : PEAK_BE_74 3m 91200_15_1620 VERTICAL          : RBW:1000.000KHz VBW:3000.000KHz SWT:Auto          Detector : Peak          Project : 090125</p>	 <p>Site : 03CH15-HY          Condition : PEAK_74 3m 91200_15_1620 VERTICAL          : RBW:1000.000KHz VBW:3000.000KHz SWT:Auto          Detector : Peak          Project : 090125</p>
Avg.	 <p>Site : 03CH15-HY          Condition : AVG_BE_54 3m 91200_15_1620 VERTICAL          : RBW:1000.000KHz VBW:0.300KHz SWT:Auto          Detector : Peak          Project : 090125</p>	 <p>Site : 03CH15-HY          Condition : AVG_54 3m 91200_15_1620 VERTICAL          : RBW:1000.000KHz VBW:0.300KHz SWT:Auto          Detector : Peak          Project : 090125</p>



2.4GHz 2400~2483.5MHz

WIFI 802.11ax HE40 Full (Band Edge @ 3m)

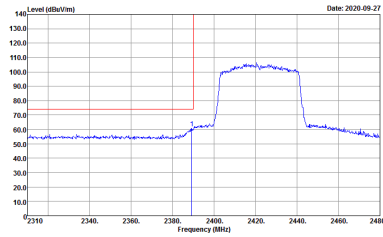
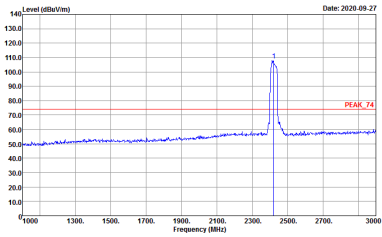
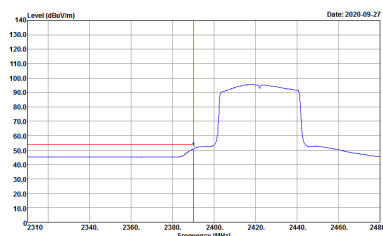
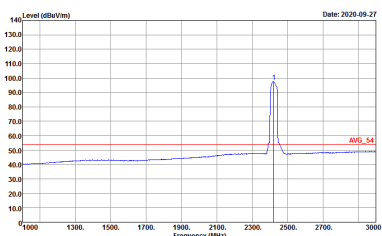
WIFI	2.4GHz 2400~2483.5MHz Band Edge @ 3m	
ANT	802.11ax HE40 Full CH03 2422MHz - L	
0+1	Horizontal	Fundamental
<b>Peak</b>	 <p>Site : 03CH15-HY            Condition : PEAK_BE_74 3m 91200_15_1620 HORIZONTAL            RBW:1000.000KHz VBW:3000.000KHz SWT:Auto            Detector : Peak            Project : 090125</p>	 <p>Site : 03CH15-HY            Condition : PEAK_74 3m 91200_15_1620 HORIZONTAL            RBW:1000.000KHz VBW:3000.000KHz SWT:Auto            Detector : Peak            Project : 090125</p>
<b>Avg.</b>	 <p>Site : 03CH15-HY            Condition : AV6_BE_54 3m 91200_15_1620 HORIZONTAL            RBW:1000.000KHz VBW:0.010KHz SWT:Auto            Detector : Peak            Project : 090125</p>	 <p>Site : 03CH15-HY            Condition : AV6_54 3m 91200_15_1620 HORIZONTAL            RBW:1000.000KHz VBW:0.010KHz SWT:Auto            Detector : Peak            Project : 090125</p>



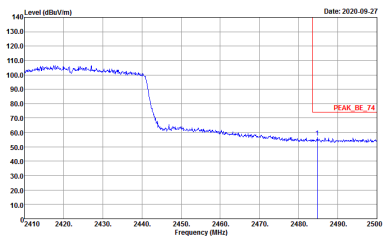
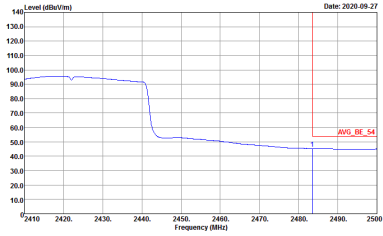

WIFI	2.4GHz 2400~2483.5MHz Band Edge @ 3m	
ANT	802.11ax HE40 Full CH03 2422MHz - R	
0+1	Horizontal	Fundamental
Peak	 <p>Site : 03CH15-HY          Condition : PEAK_BE_74 3m 91200_15_1620 HORIZONTAL          Detector : Peak          Project : 090125</p>	Left blank
Avg.	 <p>Site : 03CH15-HY          Condition : AVG_BE_54 3m 91200_15_1620 HORIZONTAL          Detector : Peak          Project : 090125</p>	Left blank



WIFI	2.4GHz 2400~2483.5MHz Band Edge @ 3m	
ANT	802.11ax HE40 Full CH03 2422MHz - L	
0+1	Vertical	Fundamental
<b>Peak</b>	<p>Site : 03CH15-HY            Condition : PEAK_BE_74 3m 91200_15_1620 VERTICAL            : RBW:1000.000KHz VBW:3000.000KHz SWT:Auto            Detector : Peak            Project : 090125</p>	<p>Site : 03CH15-HY            Condition : PEAK_74 3m 91200_15_1620 VERTICAL            : RBW:1000.000KHz VBW:3000.000KHz SWT:Auto            Detector : Peak            Project : 090125</p>
<b>Avg.</b>	<p>Site : 03CH15-HY            Condition : AVG_BE_54 3m 91200_15_1620 VERTICAL            : RBW:1000.000KHz VBW:0.010KHz SWT:Auto            Detector : Peak            Project : 090125</p>	<p>Site : 03CH15-HY            Condition : AVG_54 3m 91200_15_1620 VERTICAL            : RBW:1000.000KHz VBW:0.010KHz SWT:Auto            Detector : Peak            Project : 090125</p>

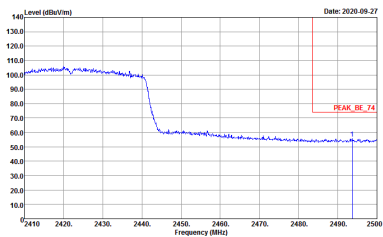
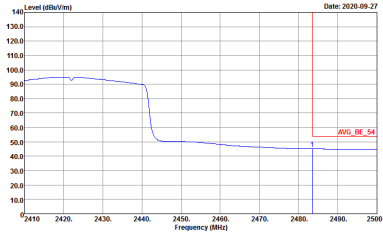

WIFI	2.4GHz 2400~2483.5MHz Band Edge @ 3m	
ANT	802.11ax HE40 Full CH03 2422MHz - R	
0+1	Vertical	Fundamental
Peak	 <p>Site : 03CH15-HY          Condition : PEAK_BE_74 3m 91200_15_1620 VERTICAL          Detector : Peak          Project : 090125</p>	Left blank
Avg.	 <p>Site : 03CH15-HY          Condition : AVG_BE_54 3m 91200_15_1620 VERTICAL          Detector : Peak          Project : 090125</p>	Left blank

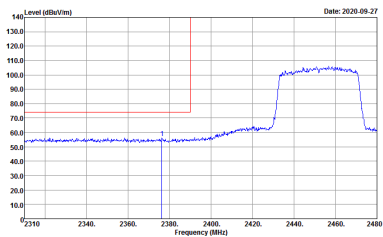
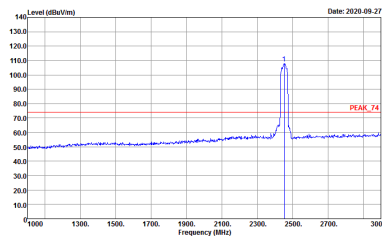
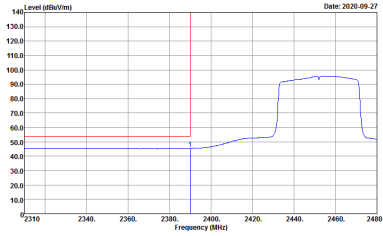
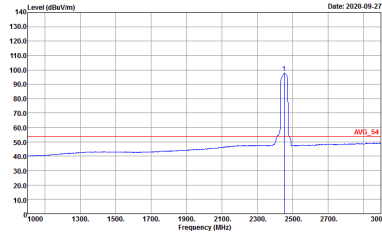

WIFI	2.4GHz 2400~2483.5MHz Band Edge @ 3m	
ANT	802.11ax HE40 Full CH09 2452MHz - L	
0+1	Horizontal	Fundamental
Peak	 <p>Site : 03CH15-HY          Condition : PEAK_BE_74 3m 91200_15_1620 HORIZONTAL          : RBW:1000.000KHz VBW:3000.000KHz SWT:Auto          Detector : Peak          Project : 090125</p>	 <p>Site : 03CH15-HY          Condition : PEAK_74 3m 91200_15_1620 HORIZONTAL          : RBW:1000.000KHz VBW:3000.000KHz SWT:Auto          Detector : Peak          Project : 090125</p>
Avg.	 <p>Site : 03CH15-HY          Condition : AVG_BE_54 3m 91200_15_1620 HORIZONTAL          : RBW:1000.000KHz VBW:0.010KHz SWT:Auto          Detector : Peak          Project : 090125</p>	 <p>Site : 03CH15-HY          Condition : AVG_54 3m 91200_15_1620 HORIZONTAL          : RBW:1000.000KHz VBW:0.010KHz SWT:Auto          Detector : Peak          Project : 090125</p>



WIFI	2.4GHz 2400~2483.5MHz Band Edge @ 3m	
ANT	802.11ax HE40 Full CH09 2452MHz - R	
0+1	Horizontal	Fundamental
<b>Peak</b>	<p>Site : 03CH15-HY Condition : PEAK_BE_74 3m 91200_15_1620 HORIZONTAL Detector : RBW:1000.000KHz VBW:3000.000KHz SWT:Auto Project : 090125</p>	Left blank
<b>Avg.</b>	<p>Site : 03CH15-HY Condition : AVG_BE_54 3m 91200_15_1620 HORIZONTAL Detector : RBW:1000.000KHz VBW:3000.000KHz SWT:Auto Project : 090125</p>	Left blank

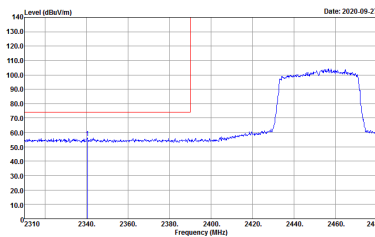
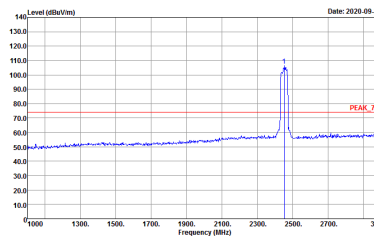
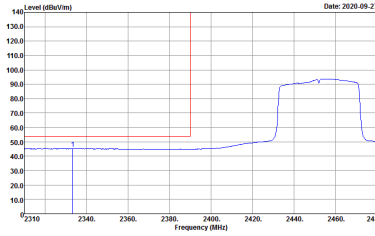
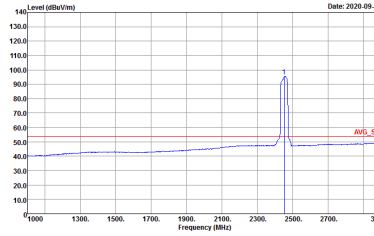

WIFI	2.4GHz 2400~2483.5MHz Band Edge @ 3m	
ANT	802.11ax HE40 Full CH09 2452MHz - L	
0+1	Vertical	Fundamental
Peak	 <p>Date: 2020-09-27</p> <p>Site : 03CH15-HY            Condition : PEAK_BE_74 3m 91200_15_1620 VERTICAL            : RBW:1000.000KHz VBW:3000.000KHz SWT:Auto            Detector : Peak            Project : 090125</p>	 <p>Date: 2020-09-27</p> <p>Site : 03CH15-HY            Condition : PEAK_74 3m 91200_15_1620 VERTICAL            : RBW:1000.000KHz VBW:3000.000KHz SWT:Auto            Detector : Peak            Project : 090125</p>
Avg.	 <p>Date: 2020-09-27</p> <p>Site : 03CH15-HY            Condition : AVG_BE_54 3m 91200_15_1620 VERTICAL            : RBW:1000.000KHz VBW:0.010KHz SWT:Auto            Detector : Peak            Project : 090125</p>	 <p>Date: 2020-09-27</p> <p>Site : 03CH15-HY            Condition : AVG_54 3m 91200_15_1620 VERTICAL            : RBW:1000.000KHz VBW:0.010KHz SWT:Auto            Detector : Peak            Project : 090125</p>



WIFI	2.4GHz 2400~2483.5MHz Band Edge @ 3m	
ANT	802.11ax HE40 Full CH09 2452MHz - R	
0+1	Vertical	Fundamental
Peak	<p>Site : 03CH15-HY Condition : PEAK_BE_74 3m 91200_15_1620 VERTICAL RBW:1000.000KHz, VBW:3000.000KHz, SWT:Auto Detector : Peak Project : 090125</p>	Left blank
Avg.	<p>Site : 03CH15-HY Condition : AVG_BE_54 3m 91200_15_1620 VERTICAL RBW:1000.000KHz, VBW:3000.000KHz, SWT:Auto Detector : Peak Project : 090125</p>	Left blank



2.4GHz 2400~2483.5MHz

WIFI 802.11ax HE40 Partial 242 (Band Edge @ 3m)

WIFI	2.4GHz 2400~2483.5MHz Band Edge @ 3m	
ANT	802.11ax HE40 Partial 242/61 CH03 2422MHz - L	
0+1	Horizontal	Fundamental
Peak	<p>Site : 03CH15-HY            Condition : PEAK_BE_74 3m 91200_15_1620 HORIZONTAL            RBW:1000.000KHz VBW:3000.000KHz SWT:Auto            Detector : Peak            Project : 090125</p>	<p>Site : 03CH15-HY            Condition : PEAK_74 3m 91200_15_1620 HORIZONTAL            RBW:1000.000KHz VBW:3000.000KHz SWT:Auto            Detector : Peak            Project : 090125</p>
Avg.	<p>Site : 03CH15-HY            Condition : AVG_BE_54 3m 91200_15_1620 HORIZONTAL            RBW:1000.000KHz VBW:0.300KHz SWT:Auto            Detector : Peak            Project : 090125</p>	<p>Site : 03CH15-HY            Condition : AVG_54 3m 91200_15_1620 HORIZONTAL            RBW:1000.000KHz VBW:0.300KHz SWT:Auto            Detector : Peak            Project : 090125</p>



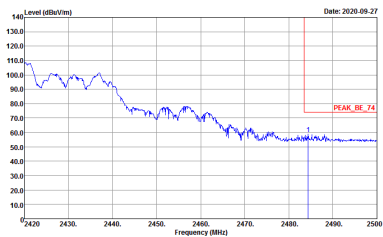
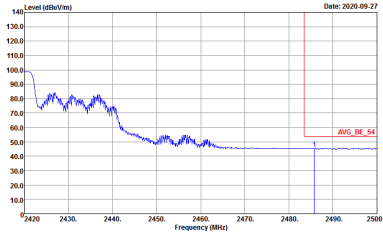

WIFI	2.4GHz 2400~2483.5MHz Band Edge @ 3m	
ANT	802.11ax HE40 Partial 242/61 CH03 2422MHz - R	
0+1	Horizontal	Fundamental
<p><b>Peak</b></p>	 <p>Site : 03CH15-HY            Condition : PEAK_BE_74 3m 91200_15_1620 HORIZONTAL            Detector : Peak            Project : 090125</p>	<p>Left blank</p>
<p><b>Avg.</b></p>	 <p>Site : 03CH15-HY            Condition : AVG_BE_54 3m 91200_15_1620 HORIZONTAL            Detector : Peak            Project : 090125</p>	<p>Left blank</p>

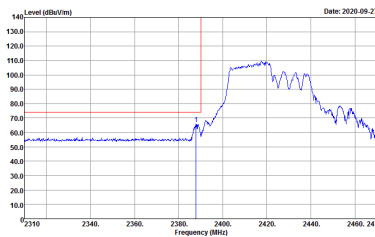
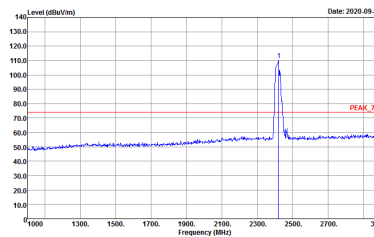
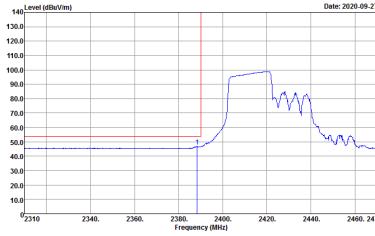
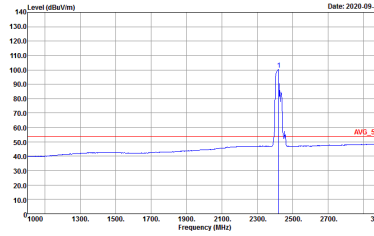

WIFI	2.4GHz 2400~2483.5MHz Band Edge @ 3m	
ANT	802.11ax HE40 Partial 242/61 CH03 2422MHz - L	
0+1	Vertical	Fundamental
Peak	 <p>Date: 2020-09-27</p> <p>Site : 03CH15-HY            Condition : PEAK_BE_74 3m 91200_15_1620 VERTICAL            : RBW:1000.000KHz VBW:3000.000KHz SWT:Auto            Detector : Peak            Project : 090125</p>	 <p>Date: 2020-09-27</p> <p>Site : 03CH15-HY            Condition : PEAK_74 3m 91200_15_1620 VERTICAL            : RBW:1000.000KHz VBW:3000.000KHz SWT:Auto            Detector : Peak            Project : 090125</p>
Avg.	 <p>Date: 2020-09-27</p> <p>Site : 03CH15-HY            Condition : AVG_BE_54 3m 91200_15_1620 VERTICAL            : RBW:1000.000KHz VBW:0.300KHz SWT:Auto            Detector : Peak            Project : 090125</p>	 <p>Date: 2020-09-27</p> <p>Site : 03CH15-HY            Condition : AVG_54 3m 91200_15_1620 VERTICAL            : RBW:1000.000KHz VBW:0.300KHz SWT:Auto            Detector : Peak            Project : 090125</p>

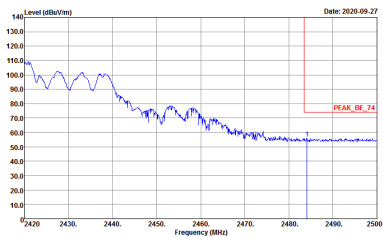
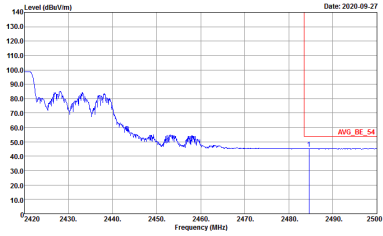

WIFI	2.4GHz 2400~2483.5MHz Band Edge @ 3m	
ANT	802.11ax HE40 Partial 242/61 CH03 2422MHz - R	
0+1	Vertical	Fundamental
<p><b>Peak</b></p>	 <p>Site : 03CH15-HY            Condition : PEAK_BE_74 3m 91200_15_1620 VERTICAL            Detector : Peak            Project : 090125</p>	<p>Left blank</p>
<p><b>Avg.</b></p>	 <p>Site : 03CH15-HY            Condition : AVG_BE_54 3m 91200_15_1620 VERTICAL            Detector : Peak            Project : 090125</p>	<p>Left blank</p>

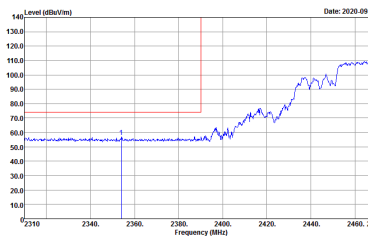
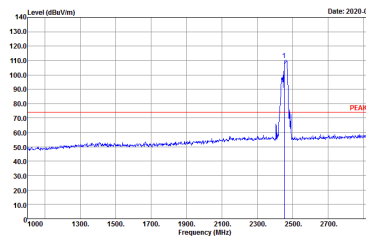
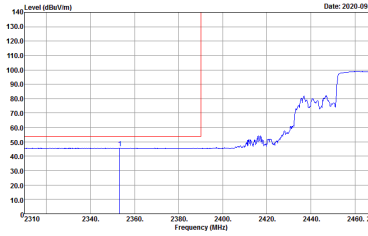
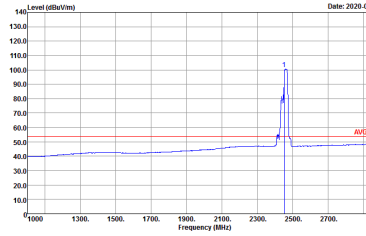

WIFI	2.4GHz 2400~2483.5MHz Band Edge @ 3m	
ANT	802.11ax HE40 Partial 242/62 CH09 2452MHz - L	
0+1	Horizontal	Fundamental
Peak	 <p>Date: 2020-09-27</p> <p>Site : 03CH15-HY            Condition : PEAK_BE_74 3m 91200_15_1620 HORIZONTAL            : RBW:1000.000KHz VBW:3000.000KHz SWT:Auto            Detector : Peak            Project : 090125</p>	 <p>Date: 2020-09-27</p> <p>Site : 03CH15-HY            Condition : PEAK_74 3m 91200_15_1620 HORIZONTAL            : RBW:1000.000KHz VBW:3000.000KHz SWT:Auto            Detector : Peak            Project : 090125</p>
Avg.	 <p>Date: 2020-09-27</p> <p>Site : 03CH15-HY            Condition : AVG_BE_54 3m 91200_15_1620 HORIZONTAL            : RBW:1000.000KHz VBW:3000.000KHz SWT:Auto            Detector : Peak            Project : 090125</p>	 <p>Date: 2020-09-27</p> <p>Site : 03CH15-HY            Condition : AVG_54 3m 91200_15_1620 HORIZONTAL            : RBW:1000.000KHz VBW:3000.000KHz SWT:Auto            Detector : Peak            Project : 090125</p>

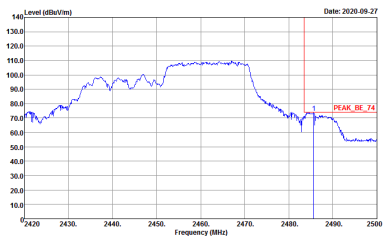
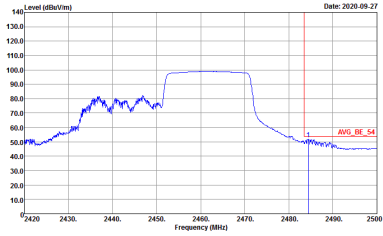

WIFI	2.4GHz 2400~2483.5MHz Band Edge @ 3m	
ANT	802.11ax HE40 Partial 242/62 CH09 2452MHz - R	
0+1	Horizontal	Fundamental
<p><b>Peak</b></p>	 <p>Site : 03CH15-HY            Condition : PEAK_BE_74 3m 91200_15_1620 HORIZONTAL            Detector : Peak            Project : 090125</p>	<p>Left blank</p>
<p><b>Avg.</b></p>	 <p>Site : 03CH15-HY            Condition : AVG_BE_54 3m 91200_15_1620 HORIZONTAL            Detector : Peak            Project : 090125</p>	<p>Left blank</p>

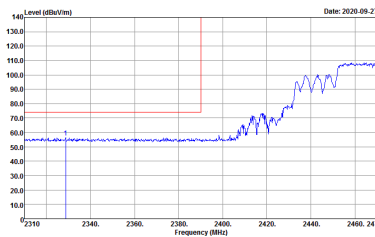
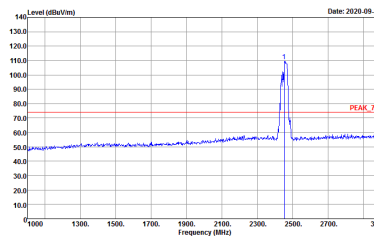
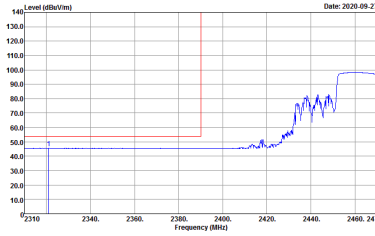
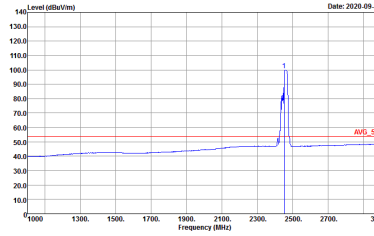

WIFI	2.4GHz 2400~2483.5MHz Band Edge @ 3m	
ANT	802.11ax HE40 Partial 242/62 CH09 2452MHz - L	
0+1	Vertical	Fundamental
Peak	 <p>Date: 2020-09-27</p> <p>Site : 03CH15-HY            Condition : PEAK_BE_74 3m 91200_15_1620 VERTICAL            : RBW:1000.000KHz VBW:3000.000KHz SWT:Auto            Detector : Peak            Project : 090125</p>	 <p>Date: 2020-09-27</p> <p>Site : 03CH15-HY            Condition : PEAK_74 3m 91200_15_1620 VERTICAL            : RBW:1000.000KHz VBW:3000.000KHz SWT:Auto            Detector : Peak            Project : 090125</p>
Avg.	 <p>Date: 2020-09-27</p> <p>Site : 03CH15-HY            Condition : AVG_BE_54 3m 91200_15_1620 VERTICAL            : RBW:1000.000KHz VBW:3000.000KHz SWT:Auto            Detector : Peak            Project : 090125</p>	 <p>Date: 2020-09-27</p> <p>Site : 03CH15-HY            Condition : AVG_54 3m 91200_15_1620 VERTICAL            : RBW:1000.000KHz VBW:3000.000KHz SWT:Auto            Detector : Peak            Project : 090125</p>

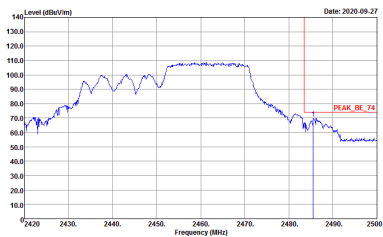
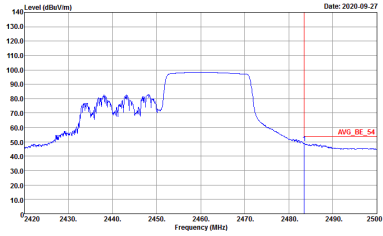

WIFI	2.4GHz 2400~2483.5MHz Band Edge @ 3m	
ANT	802.11ax HE40 Partial 242/62 CH09 2452MHz - R	
0+1	Vertical	Fundamental
<p><b>Peak</b></p>	 <p>Site : 03CH15-HY            Condition : PEAK_BE_74 3m 91200_15_1620 VERTICAL            Detector : Peak            Project : 090125</p>	<p>Left blank</p>
<p><b>Avg.</b></p>	 <p>Site : 03CH15-HY            Condition : AVG_BE_54 3m 91200_15_1620 VERTICAL            Detector : Peak            Project : 090125</p>	<p>Left blank</p>



**2.4GHz 2400~2483.5MHz**  
**WIFI 802.11b (Harmonic @ 3m)**

<b>WIFI</b>	<b>2.4GHz 2400~2483.5MHz Harmonic @ 3m</b>	
<b>ANT</b>	<b>802.11b CH01 2412MHz</b>	
<b>0+1</b>	<b>Horizontal</b>	<b>Vertical</b>
<b>Peak</b> <b>Avg.</b>	<p>Site : 03CH15-HY          Condition : PEAK_74 3m 91200_15_1620 HORIZONTAL          Detector : Peak          Project : 090125</p>	<p>Site : 03CH15-HY          Condition : PEAK_74 3m 91200_15_1620 VERTICAL          Detector : Peak          Project : 090125</p>





<b>WIFI</b>	<b>2.4GHz 2400~2483.5MHz Harmonic @ 3m</b>	
<b>ANT</b>	<b>802.11b CH06 2437MHz</b>	
<b>0+1</b>	<b>Horizontal</b>	<b>Vertical</b>
<b>Peak</b> <b>Avg.</b>	<p>Site : 03CH15-11Y Condition : PEAK_74 3m 91200_15_1620 HORIZONTAL Detector : Peak Project : 090125</p>	<p>Site : 03CH15-11Y Condition : PEAK_74 3m 91200_15_1620 VERTICAL Detector : Peak Project : 090125</p>



WIFI	2.4GHz 2400~2483.5MHz Harmonic @ 3m	
ANT	802.11b CH11 2462MHz	
0+1	Horizontal	Vertical
Peak Avg.	<p>Site : 03CH15-11Y Condition : PEAK_74 3m 91200_15_1620 HORIZONTAL Detector : Peak Project : 090125</p>	<p>Site : 03CH15-11Y Condition : PEAK_74 3m 91200_15_1620 VERTICAL Detector : Peak Project : 090125</p>



2.4GHz 2400~2483.5MHz  
WIFI 802.11g (Harmonic @ 3m)

WIFI	2.4GHz 2400~2483.5MHz Harmonic @ 3m	
ANT	802.11g CH01 2412MHz	
0+1	Horizontal	Vertical
Peak Avg.	<p>Site : 03CH15-HY Condition : PEAK_74 3m 91200_15_1620 HORIZONTAL Detector : Peak Project : 090125</p>	<p>Site : 03CH15-HY Condition : PEAK_74 3m 91200_15_1620 VERTICAL Detector : Peak Project : 090125</p>



<b>WIFI</b>	<b>2.4GHz 2400~2483.5MHz Harmonic @ 3m</b>	
<b>ANT</b>	<b>802.11g CH06 2437MHz</b>	
<b>0+1</b>	<b>Horizontal</b>	<b>Vertical</b>
<b>Peak</b> <b>Avg.</b>	<p>Site : 03CH15-11Y Condition : PEAK_74 3m 91200_15_1620 HORIZONTAL Detector : Peak Project : 090125</p>	<p>Site : 03CH15-11Y Condition : PEAK_74 3m 91200_15_1620 VERTICAL Detector : Peak Project : 090125</p>



<b>WIFI</b>	<b>2.4GHz 2400~2483.5MHz Harmonic @ 3m</b>	
<b>ANT</b>	<b>802.11g CH11 2462MHz</b>	
<b>0+1</b>	<b>Horizontal</b>	<b>Vertical</b>
<b>Peak</b> <b>Avg.</b>	<p>Site : 03CH15-11Y Condition : PEAK_74 3m 91200_15_1620 HORIZONTAL Detector : Peak Project : 090125</p>	<p>Site : 03CH15-11Y Condition : PEAK_74 3m 91200_15_1620 VERTICAL Detector : Peak Project : 090125</p>



Emission below 1GHz  
2.4GHz WIFI 802.11ax HE40 Partial RU (LF)

WIFI	2.4GHz 2400~2483.5MHz	
ANT	802.11ax HE40 Partial RU LF	
0+1	Horizontal	Vertical
QP / Peak	<p>Site : 03CH15-HY Condition : QP 3m BTL06_15_41912 HORIZONTAL Detector : Peak Project : 090125</p>	<p>Site : 03CH15-HY Condition : QP 3m BTL06_15_41912 VERTICAL Detector : Peak Project : 090125</p>



## Appendix D. Duty Cycle Plots

Antenna	Band	Duty Cycle(%)	T(us)	1/T(kHz)	VBW Setting	Duty Factor(dB)
0+1	802.11b for Ant 0	98.29	-	-	10Hz	0.07
0+1	802.11b for Ant 1	97.02	684	1.46	3kHz	0.13
0+1	802.11g for Ant 0	99.00	-	-	10Hz	0.04
0+1	802.11g for Ant 1	98.51	-	-	10Hz	0.07
0+1	802.11ax20 for Ant 0 Full RU	98.73	-	-	10Hz	0.06
0+1	802.11ax20 for Ant 1 Full RU	98.20	-	-	10Hz	0.08
0+1	802.11ax20 for Ant 0 106 RU	94.91	4670	0.21	300Hz	0.23
0+1	802.11ax20 for Ant 1 106 RU	96.13	4730	0.21	300Hz	0.17
0+1	802.11ax40 for Ant 0 Full RU	98.73	-	-	10Hz	0.06
0+1	802.11ax40 for Ant 1 Full RU	99.18	-	-	10Hz	0.04
0+1	802.11ax40 for Ant 0 242 RU	96.96	4940	0.20	300Hz	0.13
0+1	802.11ax40 for Ant 1 242 RU	96.64	4595	0.22	300Hz	0.15



MIMO <Ant. 0>

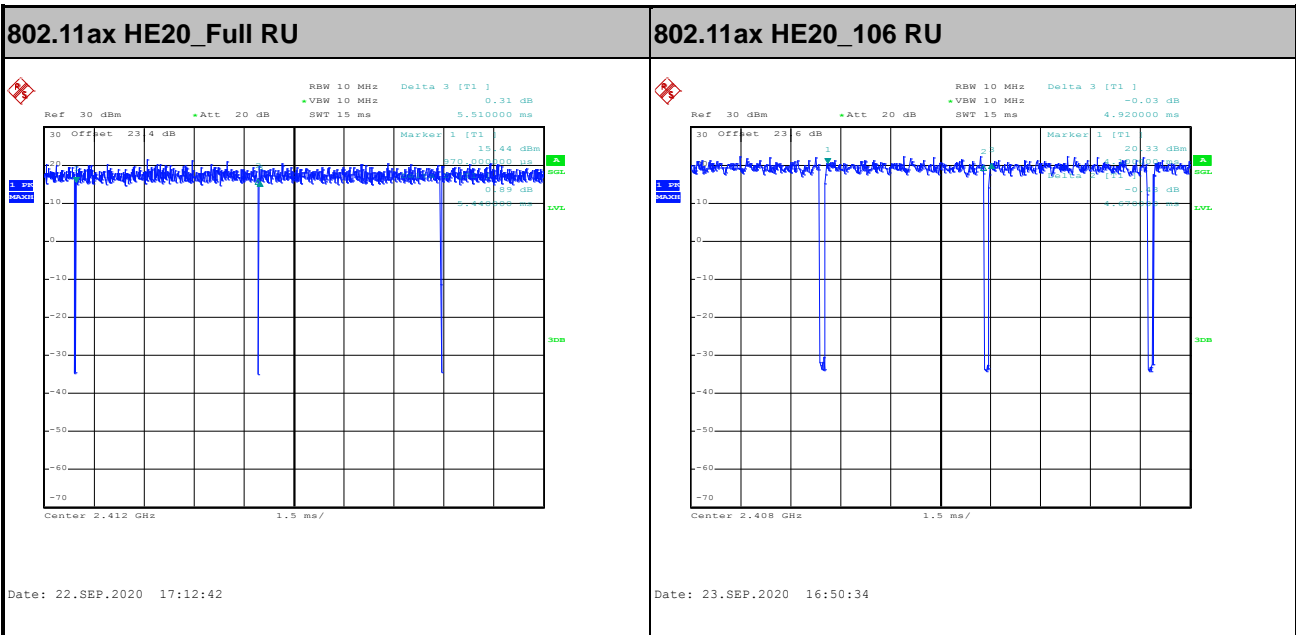
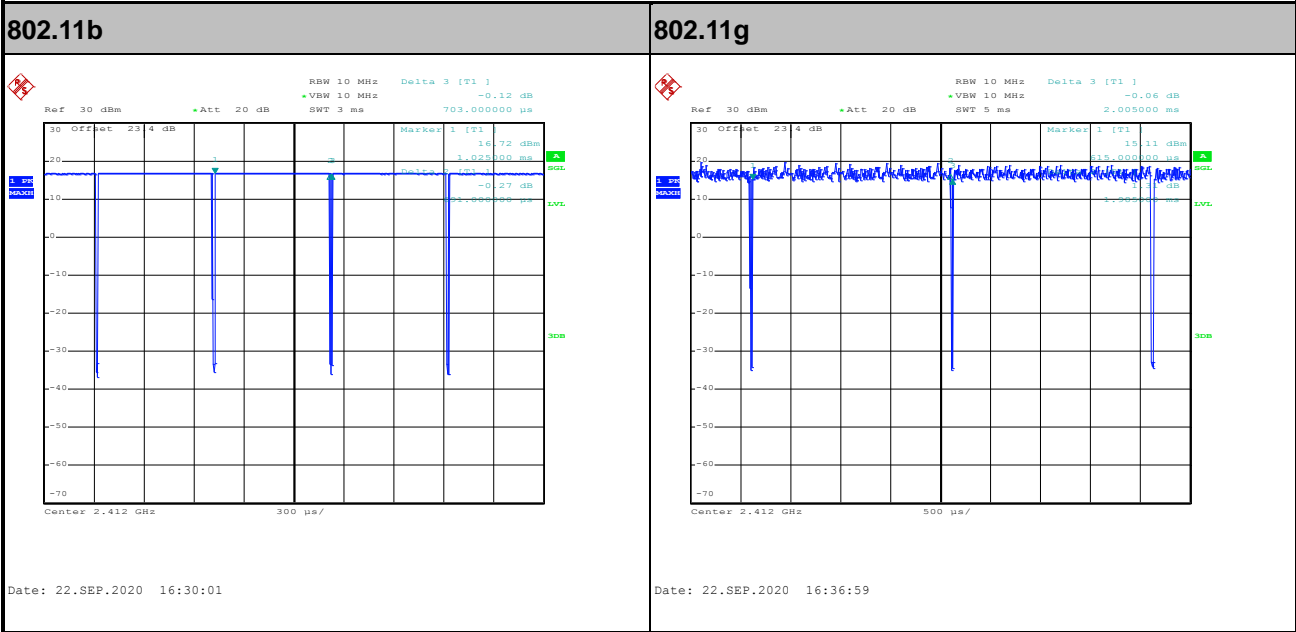



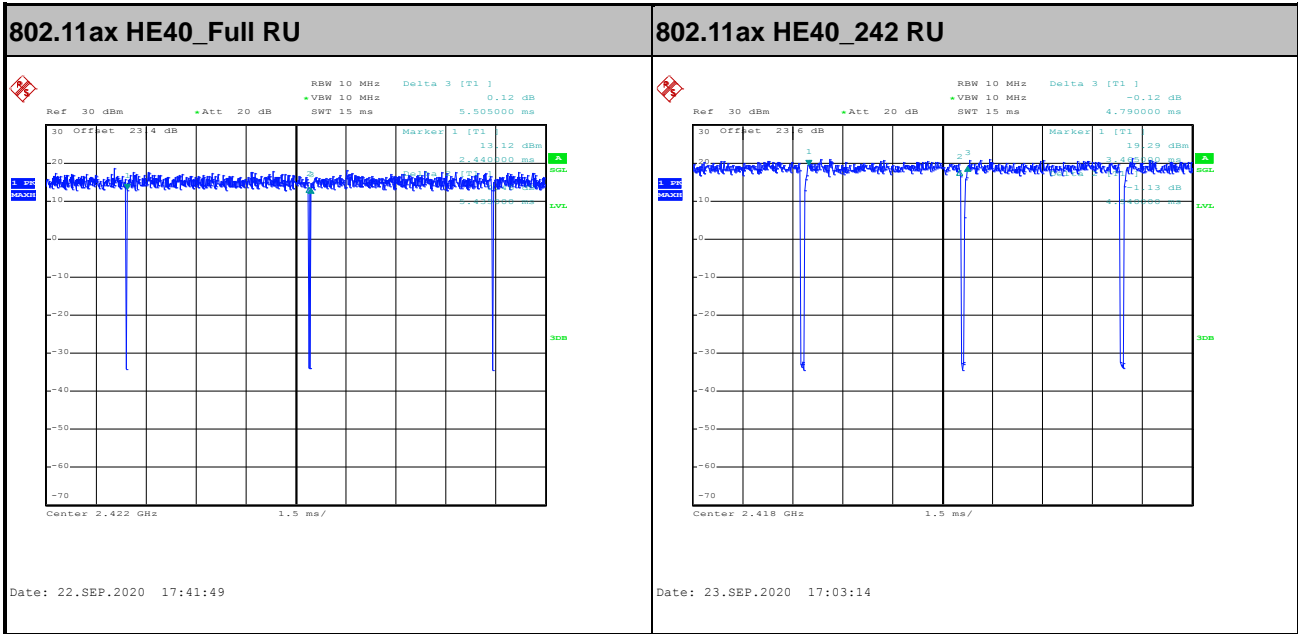

MIMO <Ant. 1>

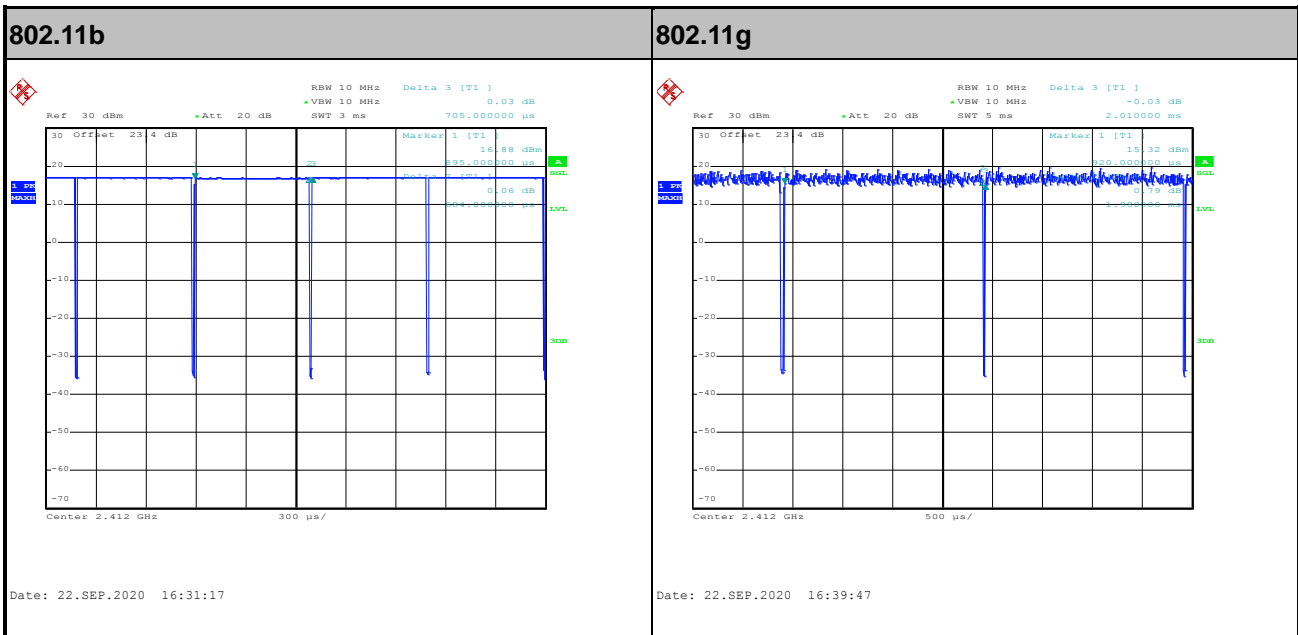



802.11ax HE20\_Full RU

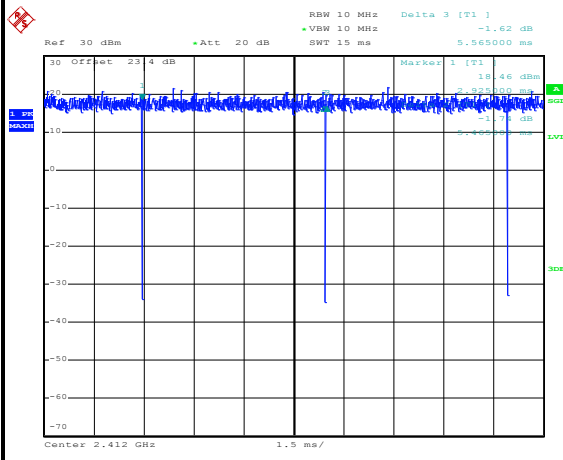

Date: 22.SEP.2020 17:17:05

802.11ax HE20\_106 RU

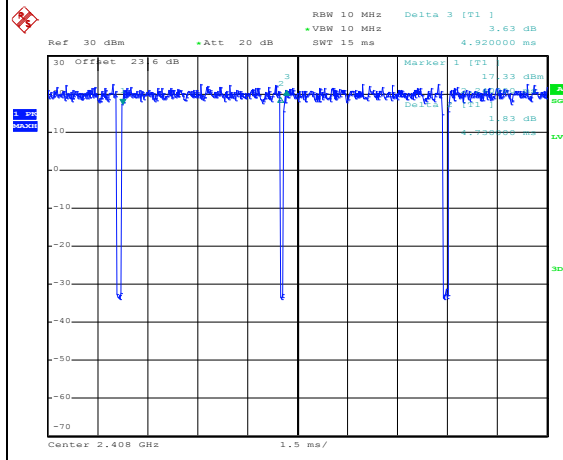

Date: 23.SEP.2020 16:51:46

802.11ax HE40\_Full RU

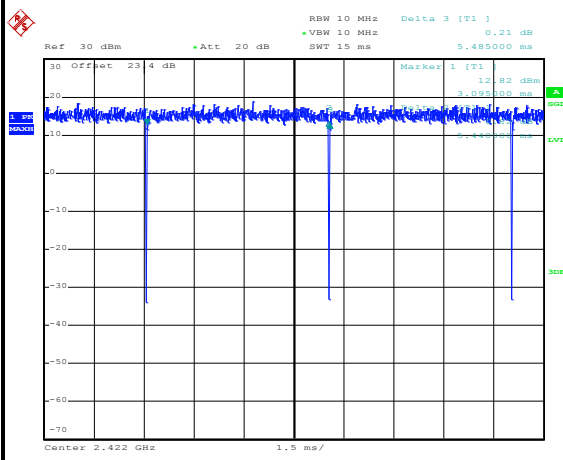

Date: 22.SEP.2020 17:44:00

802.11ax HE40\_242 RU

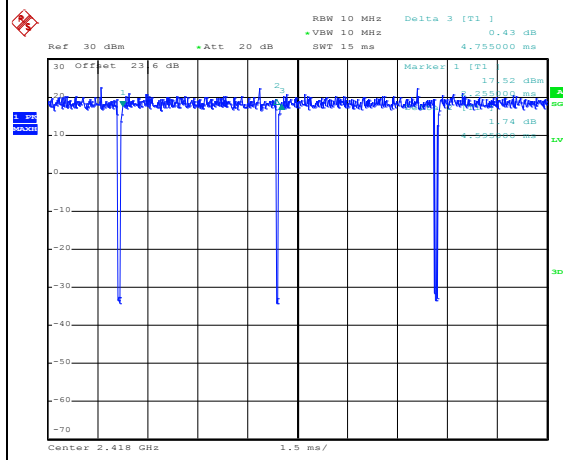

Date: 23.SEP.2020 17:04:20