



Express Lane RC

English

Age 8+

#81200

Maisto Radio Control Vehicles

Please keep this owner's instruction manual for future reference.

It contains important information.

We reserve the right to improve/revise the product specifications without notice.

WARNING! The antenna wires are not to be inserted into socket outlets.

Contents:

- RC Vehicle x 1
- RC Transmitter x 1
- Antenna Tube x 2
- Owner's Instruction Manual x 1

Battery Requirement:

Vehicle: 6 x 1.5V "AA" LR6/R6 batteries.
Transmitter: 2 x 1.5V "AAA" LR03/R03 batteries.

Battery installation for the Transmitter and Antenna Tube installation: (Refer to Diagram 1 & 2)

- Use screwdriver to loosen the screw on the battery cover and to open the battery cover. (Screwdriver is not included)
- Install 2 new 1.5V "AAA" LR03/R03 batteries with correct polarity (+/-) as shown inside the battery compartment.
- Install the battery cover and then tighten the screw on the battery cover.
- Install antenna wire into the antenna tube. Then bend down the exposed wire and insert a cover to the top end of the tube.

Battery installation for the Vehicle: (Refer to Diagram 3 & 4)

- Switch the power OFF.
- Slide open battery cover.
- Install 6 new 1.5V "AA" LR6/R6 batteries with correct polarity (+/-) as shown inside the battery compartment.
- Install the battery cover.
- WARNING!** Not suitable for children under 8 years, hot surface hazard.

Antenna Tube installation: (Refer to Diagram 5)

Insert antenna wire into the antenna tube. Pass the antenna tube through the hole in the car body. Tie a knot at the top end of the wire.

How to play: (Refer to Diagram 6, 7 & 8)

- Switch ON the vehicle.
- Pull the trigger in the transmitter to drive the vehicle forward. Push the trigger in the transmitter to drive the vehicle backward.
- Turn the transmitter steering wheel to move the vehicle left or right.
- If the vehicle does not run in a straight line, adjust the wheel alignment lever on the vehicle chassis.
- Remember to switch OFF the vehicle power after playing.

Performance Tips:

- Do not drive the vehicle on grass, sand or go through water.
- Do not drive the vehicle in windy or rainy weather.
- Do not drive the vehicle into any hard object.
- Keep fingers, hair and loose clothing away from the wheels.
- The operating range can be affected by a variety of factors:
 - weak transmitter's or vehicle batteries.
 - Interference from other items that emit radio frequency signals such as another R/C item on the same frequency, CB radios, cordless phones, high voltage transformers, etc.
- Outdoor usage is recommended in order to get optimal control range (64 feet or 20 meters).

Battery Use:

- Alkaline batteries are recommended.
- Only batteries of the same or equivalent type as recommended are to be used.
- Do not mix alkaline, standard or rechargeable batteries.
- Do not mix old and new batteries or different type of batteries.
- Non-rechargeable batteries are not to be charged.
- Rechargeable batteries are only to be charged under adult supervision.
- Rechargeable batteries are to be removed from the product before they are charged.
- Be sure to insert batteries with correct polarities and always follow the battery manufacturer's instructions.
- Remove all batteries from the product when not in use for long periods of time.
- Exhausted batteries are to be removed from the product.
- The supply terminals are not to be short-circuited.
- Dispose of batteries properly. Do not dispose of batteries in fire – it may cause them to explode or leak causing injury or damage.
- Battery change must only be made by adult.

Cautions:

- Do not attempt to disassemble the products.
- Do not operate the vehicle with same frequency with other players in same location. This will interfere and cause the vehicle to lose control.
- Make sure the batteries are installed with correct polarity (+/-) as shown inside the battery compartment.
- Remove the package, take out all accessories and assemble the product before giving it to children to play.

FCC Label Compliance Statement:

This device complies with part 15 of the FCC rules. Operation is subject to the following two conditions:

- This device may not cause harmful interference, and
- This device must accept any interference received, including interference that may cause undesired operation.

Note: This equipment has been tested and found to comply with the limits for a Class B digital device, pursuant to Part 15 of the FCC Rules. These limits are designed to provide reasonable protection against harmful interference in a residential installation. This equipment generates, uses and can radiate radio frequency energy and, if not installed and used in accordance with the instructions, may cause harmful interference to radio communications.

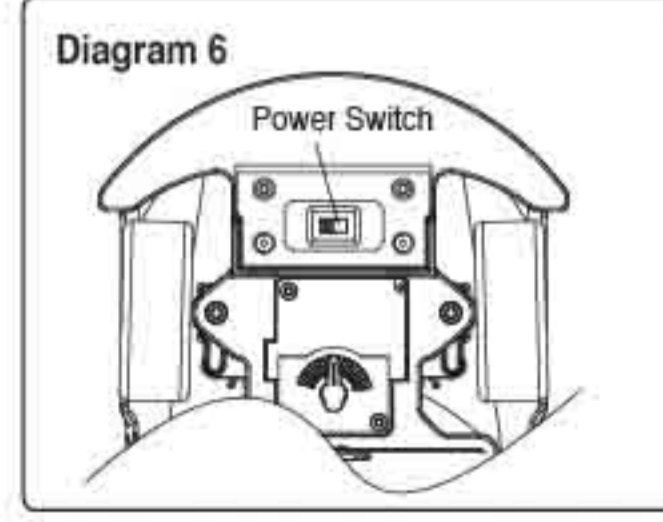
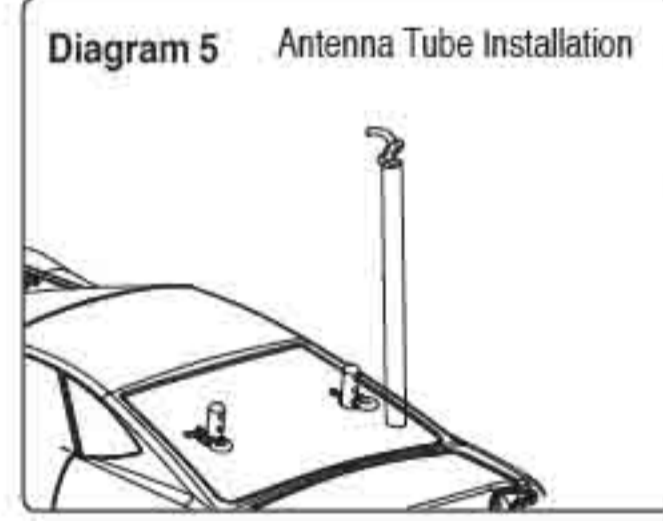
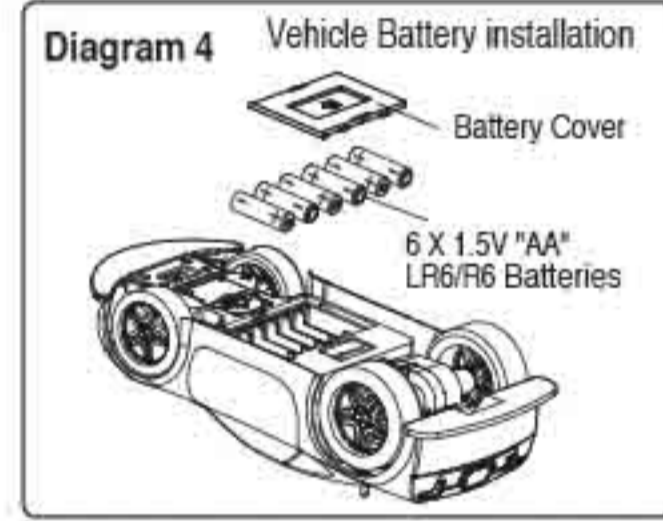
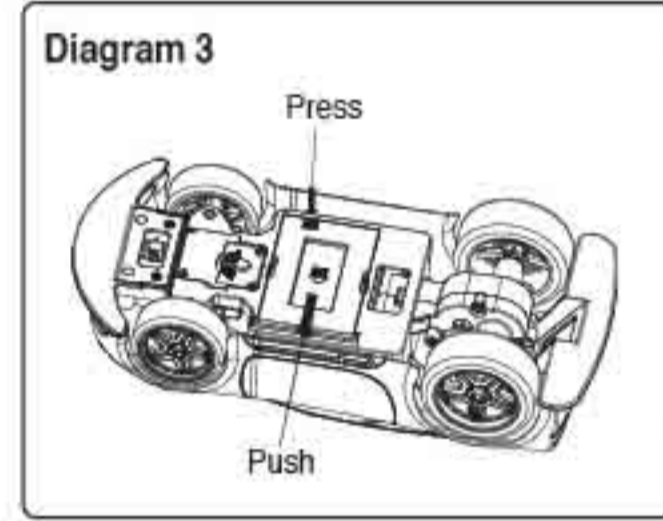
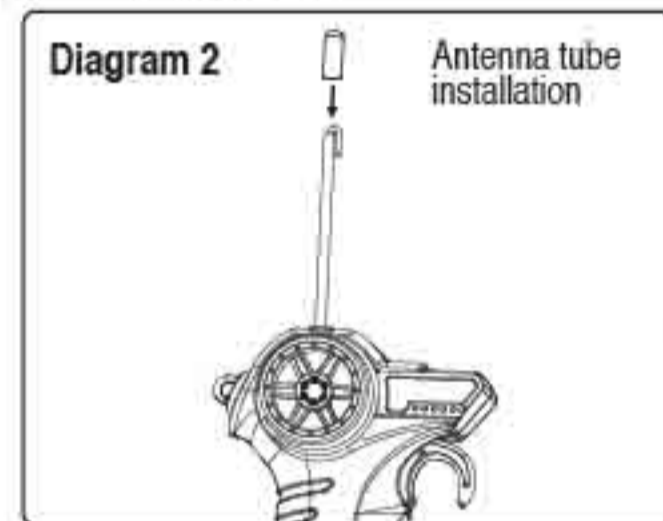
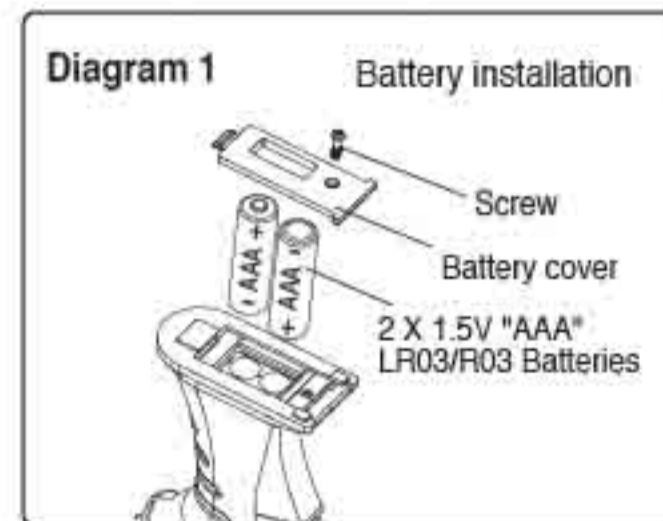

English

However, there is no guarantee that interference will not occur in a particular installation. If this equipment does cause harmful interference to radio or television reception, which can be determined by turning the equipment off and on, the user is encouraged to try to correct the interference by one or more of the following measures:

- Reorient or relocate the receiving antenna.
- Increase the separation between the equipment and receiver.
- Connect the equipment into an outlet on a circuit different from that to which the receiver is connected.
- Consult the dealer or an experienced radio/TV technician for help.

Warning: Changes or modifications to this unit not expressly approved by the party responsible for compliance could void the user's authority to operate the equipment.

Troubleshooting:

Problem	Cause	Correction
No Function	Low battery level Battery polarities are reversed The wheels are obstructed by foreign objects	Replace with new batteries Insert the batteries with correct polarities as shown on the battery compartment Remove foreign objects on the vehicle / wheels
Drive Slow / Poor Turning Signal	Low battery level The wheels are obstructed by foreign objects	Replace with new batteries Remove foreign objects on the vehicle / wheels
Poor distance control	Low battery level Strong interference of surroundings	Replace with new batteries Move to a better location for playing

Disposal of batteries

Batteries should not be disposed of in the household waste. As the consumer you are legally obliged to return batteries containing harmful substances and all other used batteries. You can hand in your old batteries at public collection points in your area or wherever batteries are sold.



You will find these chemical abbreviations along with a crossed-out refuse bin on batteries containing harmful substances:

- Pb = Battery contains lead
- Cd = Battery contains cadmium
- Hg = Battery contains mercury

Warranty

All Maisto R/C products have a 30 days limited warranty in function and performance. You may receive a new replacement product if the defective product is returned to Maisto freight prepaid and confirmed a factory defective. Maisto's 30 days warranty is limited to factory defects in material and workmanship only. The warranty does not cover unauthorized modification, accidents, abusive use, and consequential damages per our judgment. The warranty is limited to original purchaser with dated proof of purchase only. If you have a problem with our product, e-mail or call customer service first, RA # may be issued if the problem cannot be resolved over the phone or email. Return for repair or replacement must be shipped prepaid/postage prepaid and insured, include dated proof of purchase, RA# and brief description of problem. If product is returned without a dated proof of purchase, it will be excluded from the coverage of this warranty. Allow 3 to 5 weeks for delivery of repaired or replacement per Maisto's discretion. Delivery is limited in U.S.A. or Canada only. Warranty is only valid for purchases in U.S.A and Canada only. Check the FAQ section before you return the product to Maisto.

FAQ (Frequently Asked Questions)

1) Why does my R/C vehicle not start?

- Make sure the vehicle is turned on.
- Check to make sure the batteries are not drained.
- Make sure the batteries are installed per polarity indicators.
- Make sure all 4 wheels are not obstructed by any foreign objects.

2) Why does my R/C vehicle make unusual noises?

- Check to make sure the batteries are not drained.
- Check to make sure all 4 wheels are not obstructed by any foreign objects.

3) What if I'm still having a problem?

Check the FAQ and make sure all attempts have been made to make the unit work. Check your purchase receipt date and make sure it's within the 30 days warranty period at the time you intend to send it back. Contact Maisto (see below), and tell us the model that you have, the problem(s) you are having, your daytime phone number, and any other information that might be helpful for us to resolve the problem. If Maisto cannot solve your problem by mail, email or telephone, we will issue a return authorization number so you can return the unit to us for repair or replacement. **No returns will be accepted without a return authorization (RA) number issued by Maisto clearly marked on the outside of the package.** Pack the unit back in its original box or another box with sufficient protective material, include a copy of your dated store receipt and a description of the problem then send it freight prepaid to the address which we will provide when we issue the RA number.

4) Please refer to FAQ section on our website for more information.

Website: www.maisto.com
Email: customerservice@MayCheongGroup.com
Phone: (909) 357-7988
8:30 a.m. - 5:00 p.m. / Monday-Friday / Pacific Time

Maisto International, Inc., Fontana, CA 92336, U.S.A.



www.maisto.com

MADE IN CHINA

Eng (R4)

Size: A5_148.5mm(W) x 210mm(H)

Color: 1C (Black)

MAY CHEONG TOY PRODUCTS FTY. LTD.				DIECUT	
Job Item: Q0470/12R1A1 ins Eng	Finished by: Qiang	Date: 15/07/2016	Test No.:		
Item No.: Maisto TECH #81200 1:14 Express Lane RC	Check by:	DWN Name: zhaowanpeng	Material:		