

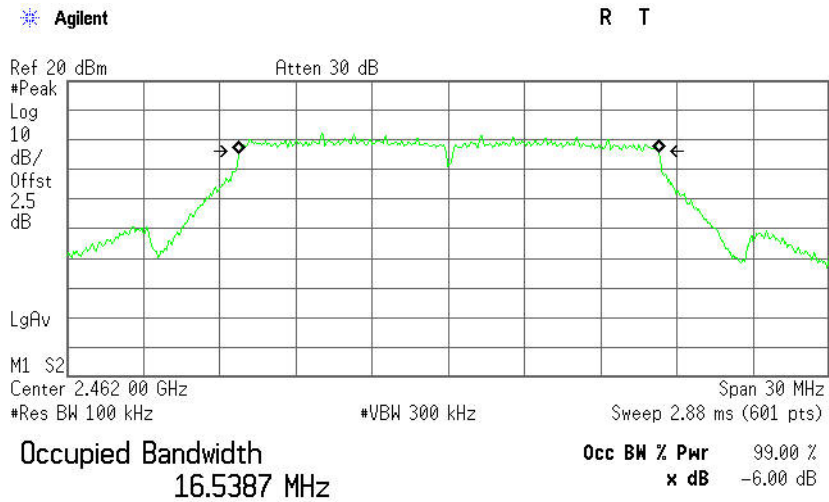

6dB Bandwidth (CH High)



Transmit Freq Error 19.004 kHz
x dB Bandwidth 16.463 MHz

IEEE 802.11g mode (Antenna 1)

6dB Bandwidth (CH Low)

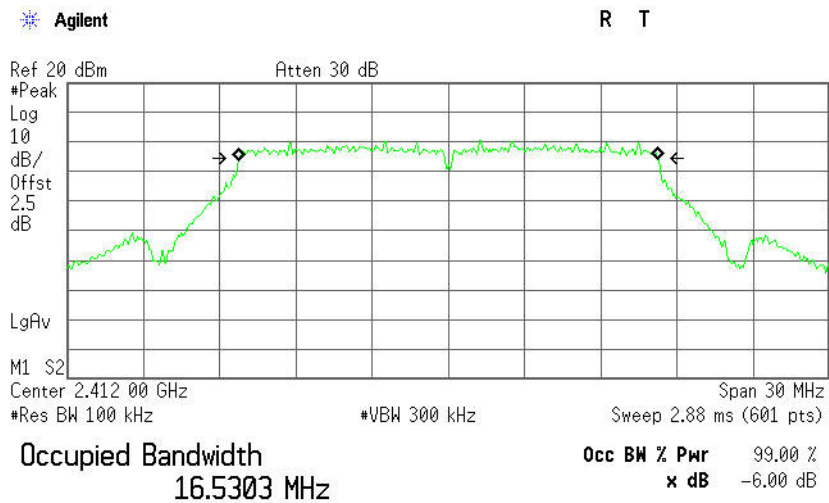

Transmit Freq Error 6.869 kHz
x dB Bandwidth 16.465 MHz



6dB Bandwidth (CH Mid)

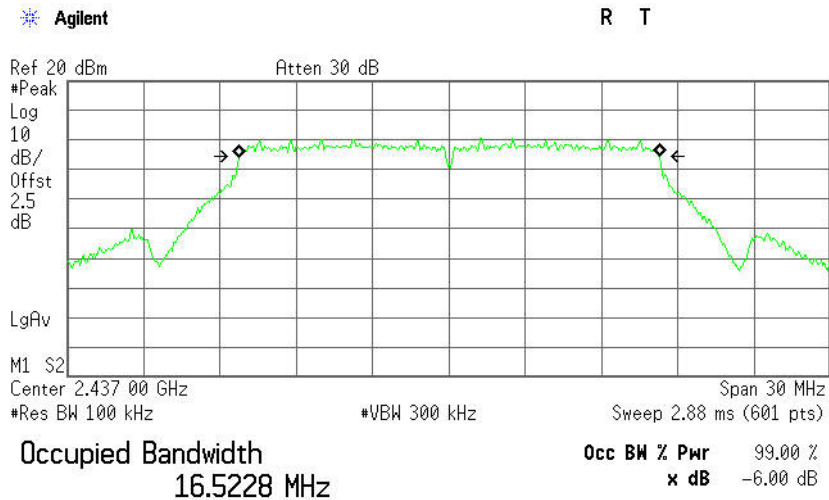

Transmit Freq Error 18.360 kHz
x dB Bandwidth 16.468 MHz

6dB Bandwidth (CH High)

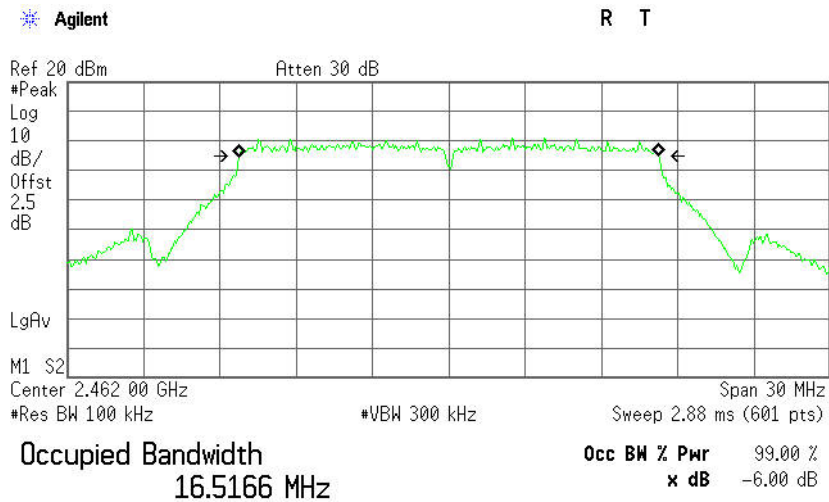

Transmit Freq Error 7.632 kHz
x dB Bandwidth 16.470 MHz



IEEE 802.11n HT20 MHz mode (Antenna 0)

6dB Bandwidth (CH Low)

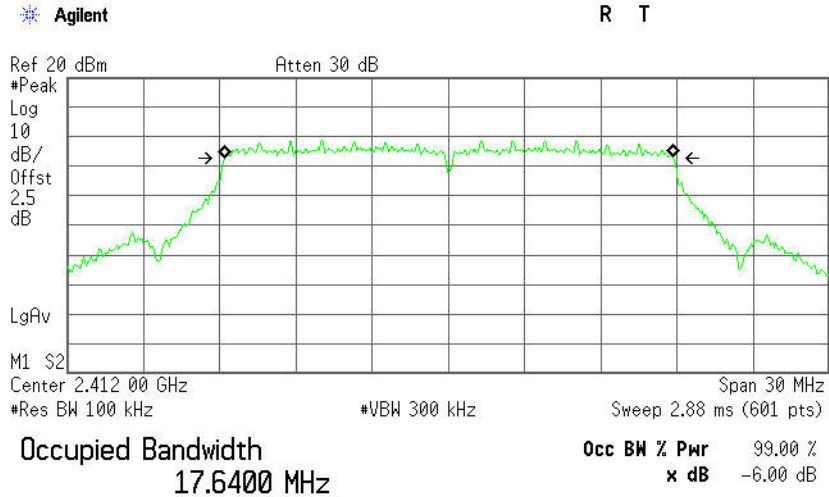

Transmit Freq Error 28.779 kHz
x dB Bandwidth 17.662 MHz

6dB Bandwidth (CH Mid)

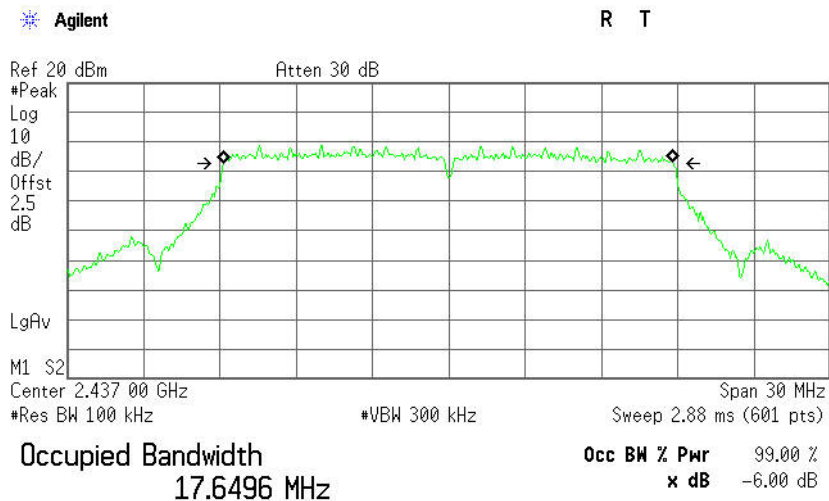

Transmit Freq Error -5.539 kHz
x dB Bandwidth 17.657 MHz



6dB Bandwidth (CH High)

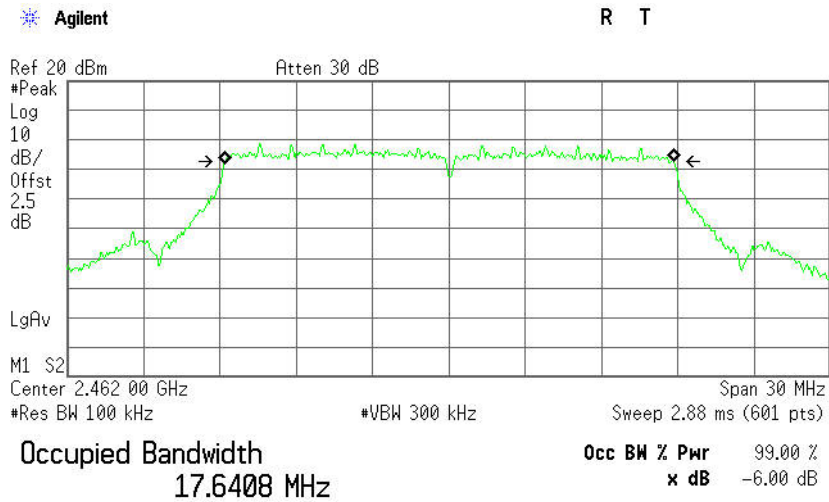

Transmit Freq Error 27.034 kHz
x dB Bandwidth 17.643 MHz

IEEE 802.11n HT20 MHz mode (Antenna 1)

6dB Bandwidth (CH Low)

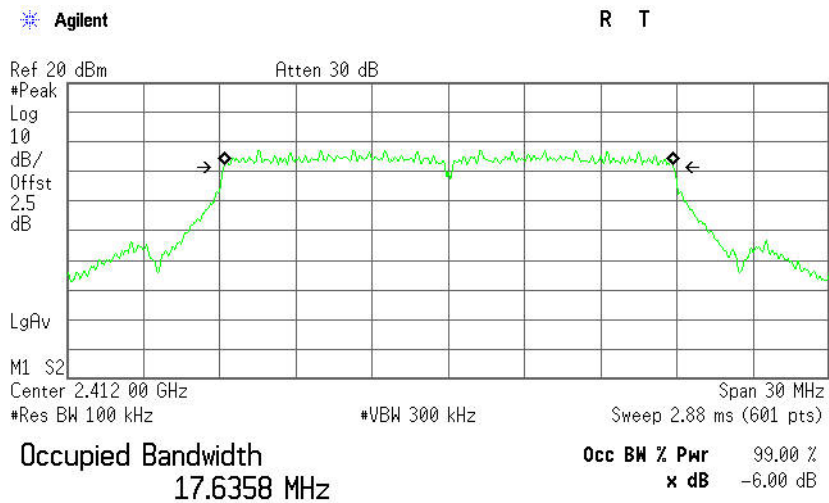

Transmit Freq Error 21.489 kHz
x dB Bandwidth 17.711 MHz



6dB Bandwidth (CH Mid)

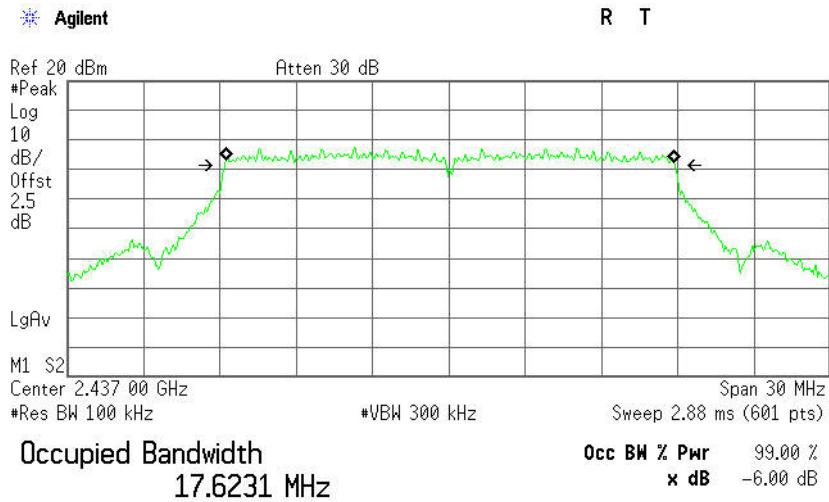

Transmit Freq Error 41.544 kHz
x dB Bandwidth 17.682 MHz

6dB Bandwidth (CH High)

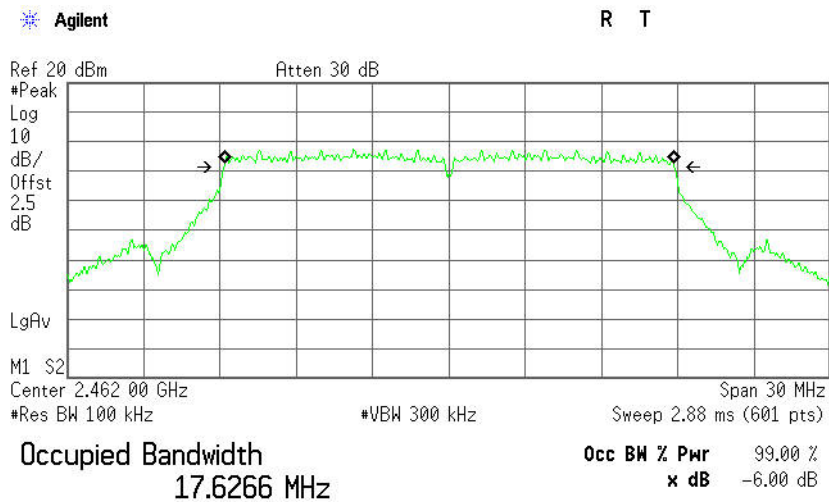

Transmit Freq Error 16.721 kHz
x dB Bandwidth 17.701 MHz



IEEE 802.11n HT40 MHz mode (Antenna 0)

6dB Bandwidth (CH Low)

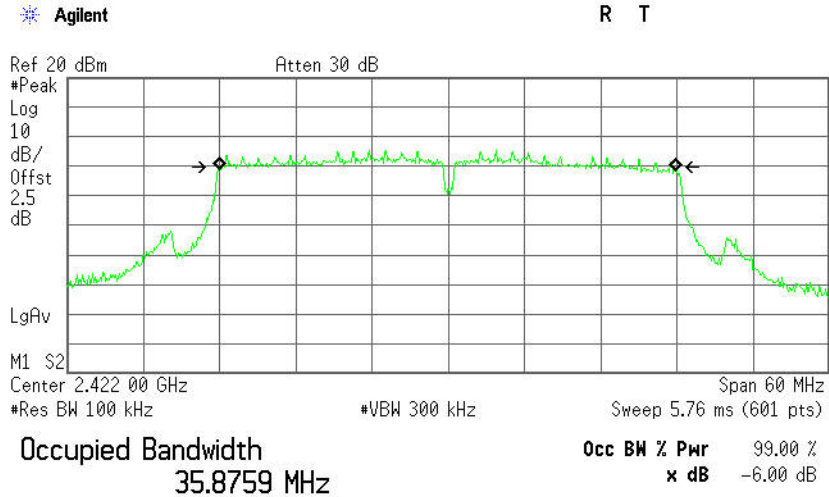

Transmit Freq Error -22.653 kHz
x dB Bandwidth 35.770 MHz

6dB Bandwidth (CH Mid)

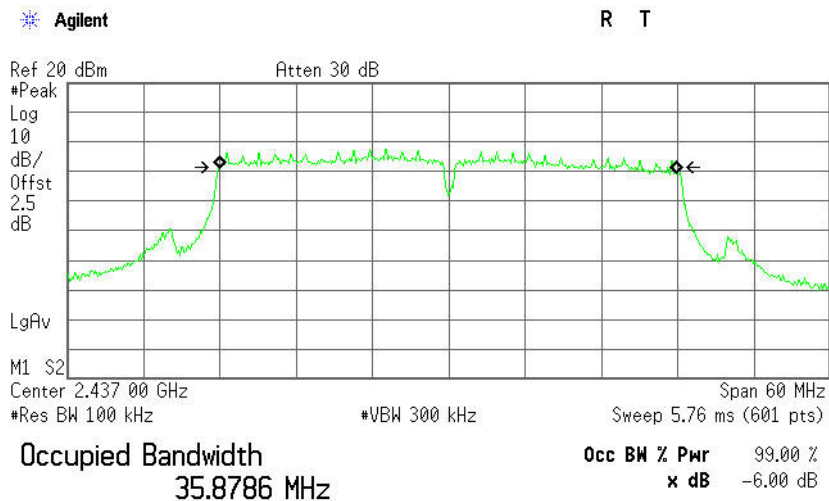

Transmit Freq Error -40.393 kHz
x dB Bandwidth 35.591 MHz



6dB Bandwidth (CH High)

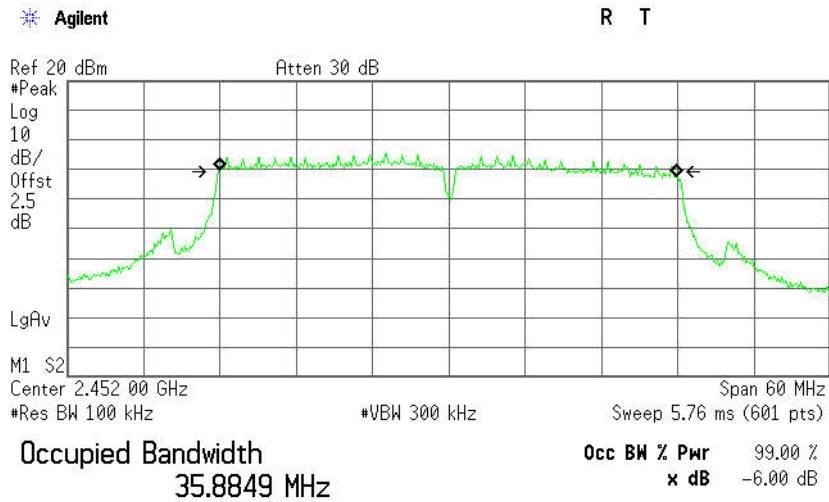

Transmit Freq Error -74.140 kHz
x dB Bandwidth 35.783 MHz

IEEE 802.11n HT40 MHz mode (Antenna 1)

6dB Bandwidth (CH Low)

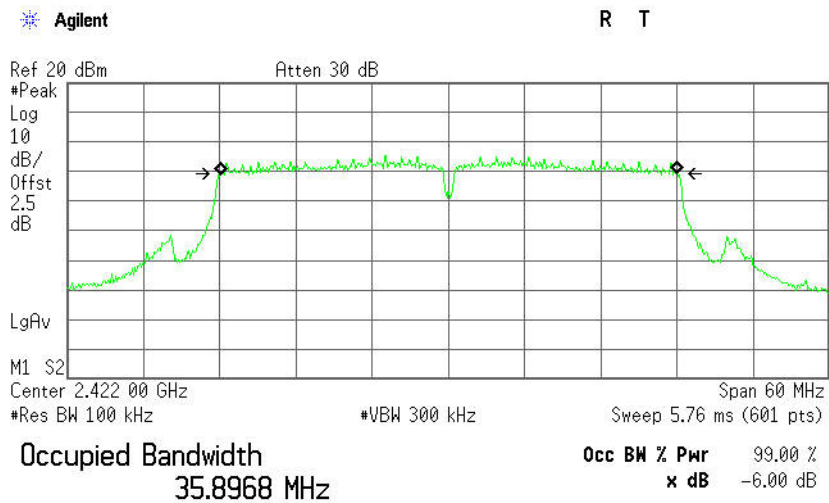

Transmit Freq Error 48.279 kHz
x dB Bandwidth 35.669 MHz



6dB Bandwidth (CH Mid)

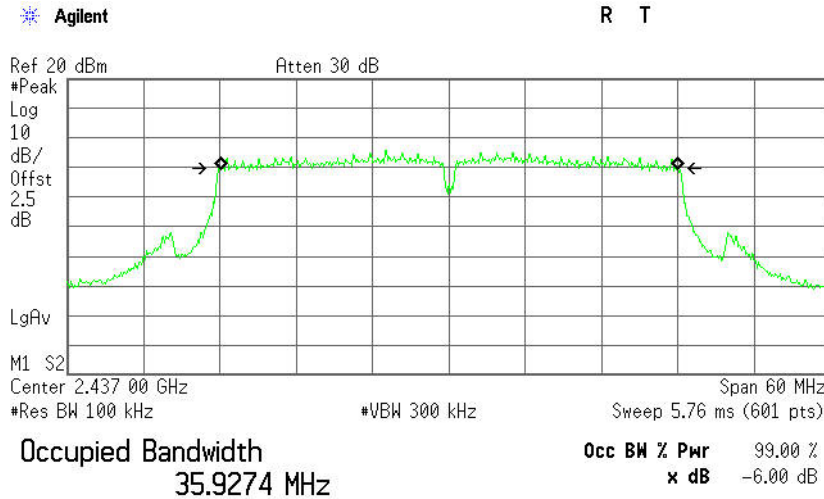

Transmit Freq Error 38.337 kHz
x dB Bandwidth 35.954 MHz

6dB Bandwidth (CH High)

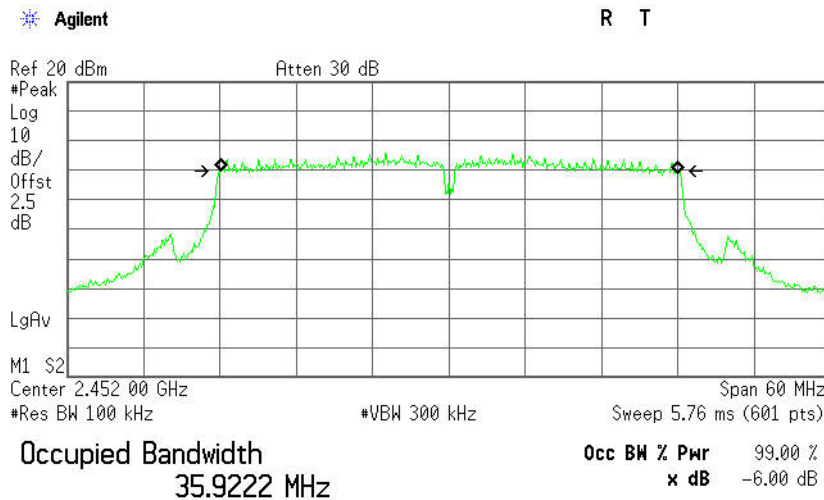

Transmit Freq Error 43.771 kHz
x dB Bandwidth 35.861 MHz



7.4. PEAK OUTPUT POWER

7.4.1. LIMITS

The maximum peak output power of the intentional radiator shall not exceed the following:

1. According to §15.247(b)(3), for systems using digital modulation in the bands of 902-928 MHz, 2400-2483.5 MHz, and 5725-5850 MHz: 1 Watt.
2. According to §15.247(b)(4), the conducted output power limit specified in paragraph (b) of this section is based on the use of antennas with directional gains that do not exceed 6 dBi. Except as shown in paragraph (c) of this section, if transmitting antennas of directional gain greater than 6 dBi are used, the conducted output power from the intentional radiator shall be reduced below the stated values in paragraphs (b)(1), (b)(2), and (b)(3) of this section, as appropriate, by the amount in dB that the directional gain of the antenna exceeds 6 dBi.

7.4.2. TEST INSTRUMENTS

Name of Equipment	Manufacturer	Model	Serial Number	Last Calibration	Calibration Due
Power Meter	Anritsu	ML2495A	1204003	03/09/2014	03/08/2015
Power Sensor	Anritsu	MA2411B	1126150	03/09/2014	03/08/2015
Spectrum Analyzer	Agilent	E4446A	US44300399	03/01/2014	03/01/2015

7.4.3. TEST PROCEDURES (please refer to measurement standard)

9.1.1 RBW \geq DTS bandwidth

This procedure shall be used when the measurement instrument has available a resolution bandwidth that is greater than the *DTS bandwidth*.

- a) Set the RBW \geq *DTS bandwidth*.
- b) Set VBW \geq 3 RBW.
- c) Set span \geq 3 x RBW
- d) Sweep time = auto couple.
- e) Detector = peak.
- f) Trace mode = max hold.
- g) Allow trace to fully stabilize.
- h) Use peak marker function to determine the peak amplitude level.



9.1.2 Integrated band power method

This procedure may be used when the maximum available RBW of the measurement instrument is less than the *DTS bandwidth*.

- a) Set the RBW = 1 MHz.
- b) Set the VBW ≥ 3 RBW
- c) Set the span $\geq 1.5 \times$ DTS bandwidth.
- d) Detector = peak.
- e) Sweep time = auto couple.
- f) Trace mode = max hold.
- g) Allow trace to fully stabilize.
- h) Use the instrument's band/channel power measurement function with the band limits set equal to the DTS bandwidth edges (for some instruments, this may require a manual override to select peak detector). If the instrument does not have a band power function, sum the spectrum levels (in linear power units) at intervals equal to the RBW extending across the DTS bandwidth.

9.1.3 PKPM1 Peak power meter method

The maximum peak conducted output power may be measured using a broadband peak RF power meter. The power meter shall have a video bandwidth that is greater than or equal to the DTS bandwidth and shall utilize a fast-responding diode detector.

7.4.4. TEST SETUP

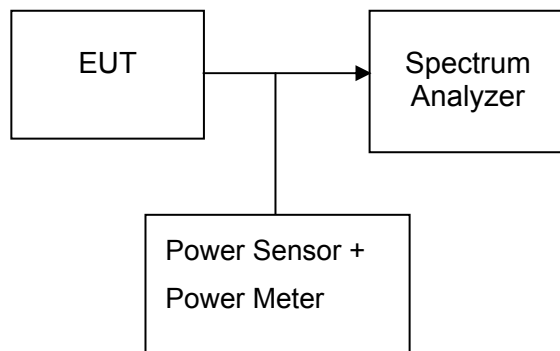



7.4.5. TEST RESULTS

No non-compliance noted

Test Data

Test mode: IEEE 802.11b (Antenna 0)

Channel	Frequency (MHz)	Output Power (dBm)	Output Power (W)	Limit (W)	Result
Low	2412	17.37	0.05458	1	PASS
Mid	2437	17.35	0.05433		PASS
High	2462	17.45	0.05559		PASS

Test mode: IEEE 802.11b (Antenna 1)

Channel	Frequency (MHz)	Output Power (dBm)	Output Power (W)	Limit (W)	Result
Low	2412	16.77	0.04753	1	PASS
Mid	2437	16.33	0.04295		PASS
High	2462	16.25	0.04217		PASS

Test mode: IEEE 802.11g (Antenna 0)

Channel	Frequency (MHz)	Output Power (dBm)	Output Power (W)	Limit (W)	Result
Low	2412	23.81	0.24044	1	PASS
Mid	2437	23.62	0.23014		PASS
High	2462	23.74	0.23659		PASS

Test mode: IEEE 802.11g (Antenna 1)

Channel	Frequency (MHz)	Output Power (dBm)	Output Power (W)	Limit (W)	Result
Low	2412	22.53	0.17906	1	PASS
Mid	2437	22.54	0.17947		PASS
High	2462	22.97	0.19815		PASS



Test mode: IEEE 802.11n HT20 MHz (Combine with Antenna 0 and Antenna 1)

Channel	Frequency (MHz)	Output Power (dBm)			Output Power (W)	Limit (W)	Result
		Chain 0	Chain 1	Total			
Low	2412	21.27	19.91	23.65	0.23192	1	PASS
Mid	2437	21.64	19.75	23.81	0.24029		PASS
High	2462	22.15	19.73	24.12	0.25803		PASS

Test mode: IEEE 802.11n HT40 MHz (Combine with Antenna 0 and Antenna 1)

Channel	Frequency (MHz)	Output Power (dBm)			Output Power (W)	Limit (W)	Result
		Chain 0	Chain 1	Total			
Low	2422	20.80	19.35	23.15	0.20633	1	PASS
Mid	2437	20.37	19.42	22.93	0.19639		PASS
High	2452	21.45	18.95	23.39	0.21816		PASS

Note : Combine Power Calculation :

$$\text{Total Power(dBm)} = \log (10^{(\text{chain 0 power}/10)} + 10^{(\text{chain 1 power}/10)}) * 10$$

Remark: The test results is undered by the third method 9.1.3 to measure the pout.



7.5. BAND EDGES MEASUREMENT

7.5.1. LIMITS

According to §15.247(d), in any 100 kHz bandwidth outside the frequency bands in which the spread spectrum intentional radiator is operating, the radio frequency power that is produced by the intentional radiator shall be at least 20 dB below that in the 100 kHz bandwidth within the band that contains the highest level of the desired power, based on either an RF conducted or a radiated measurement, provided the transmitter demonstrates compliance with the peak conducted power limits. In addition, radiated emissions which fall in the restricted bands, as defined in §15.205(a), must also comply with the radiated emission limits specified in 15.209(a) (see Section 15.205(c)).

7.5.2. TEST INSTRUMENTS

Radiated Emission Test Site 966(2)					
Name of Equipment	Manufacturer	Model Number	Serial Number	Last Calibration	Due Calibration
PSA Series Spectrum Analyzer	Agilent	E4446A	US44300399	03/01/2014	03/01/2015
EMI TEST RECEIVER	ROHDE&SCHWARZ	ESCI	100783	03/09/2014	03/08/2015
Amplifier	MITEQ	AM-1604-3000	1123808	03/18/2014	03/18/2015
High Noise Amplifier	Agilent	8449B	3008A01838	03/18/2014	03/18/2015
Board-Band Horn Antenna	Schwarzbeck	BBHA 9170	9170-497	07/10/2014	07/09/2015
Bilog Antenna	SCHAFFNER	CBL6143	5082	03/01/2014	03/01/2015
Horn Antenna	SCHWARZBECK	BBHA9120	D286	03/01/2014	03/01/2015
Loop Antenna	A. R. A	PLA-1030/B	1029	09/27/2013	09/26/2014
Turn Table	N/A	N/A	N/A	N.C.R	N.C.R
Controller	Sunol Sciences	SC104V	022310-1	N.C.R	N.C.R
Controller	CT	N/A	N/A	N.C.R	N.C.R
Temp. / Humidity Meter	Anymetre	JR913	N/A	02/28/2014	02/28/2015
Antenna Tower	SUNOL	TLT2	N/A	N.C.R	N.C.R
Test S/W	FARAD	LZ-RF / CCS-SZ-3A2			

- NOTE:** 1. The calibration interval of the above test instruments is 12 months and the calibrations are traceable to NML/ROC and NIST/USA.
2. The FCC Site Registration number is 101879.
3. N.C.R = No Calibration Required.



7.5.3. TEST PROCEDURES (please refer to measurement standard)

1. The EUT is placed on a turntable, which is 0.8m above the ground plane.
2. The turntable shall be rotated for 360 degrees to determine the position of maximum emission level.
3. EUT is set 3m away from the receiving antenna, which is varied from 1m to 4m to find out the highest emission.
4. Set the spectrum analyzer in the following setting in order to capture the lower and upper band-edges of the emission:
 - (a) PEAK: RBW=VBW=1MHz / Sweep=AUTO
 - (b) AVERAGE: RBW=1MHz / VBW=10Hz / Sweep=AUTO
5. Repeat the procedures until all the PEAK and AVERAGE versus POLARIZATION are

7.5.4. TEST SETUP

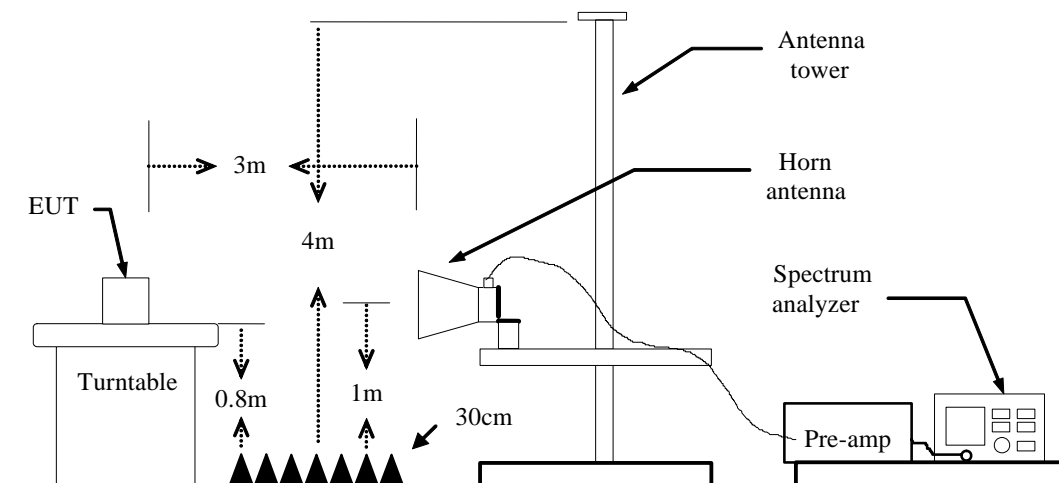



7.5.5. TEST RESULTS

Test Plot

IEEE 802.11b mode (Antenna 0)

Band Edges (CH Low)

Detector mode: Peak

Polarity: Vertical

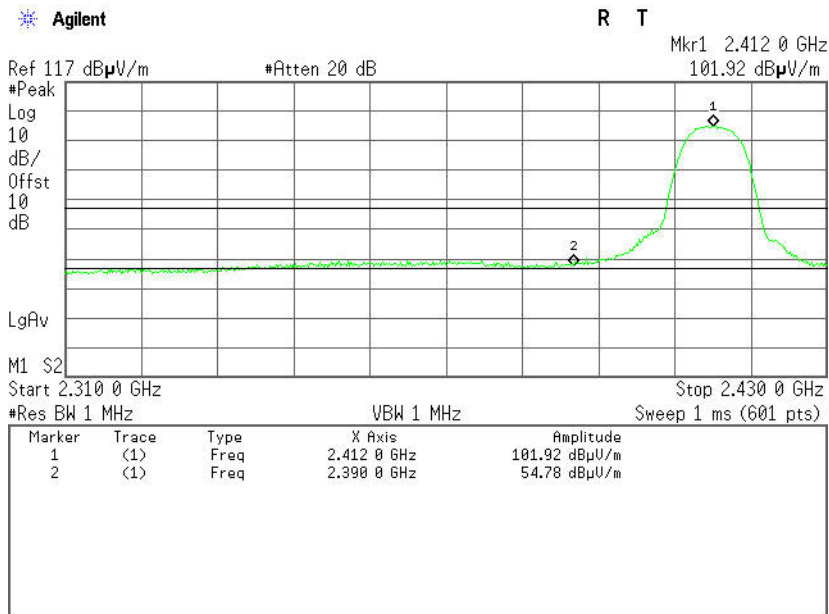

Detector mode: Average

Polarity: Vertical

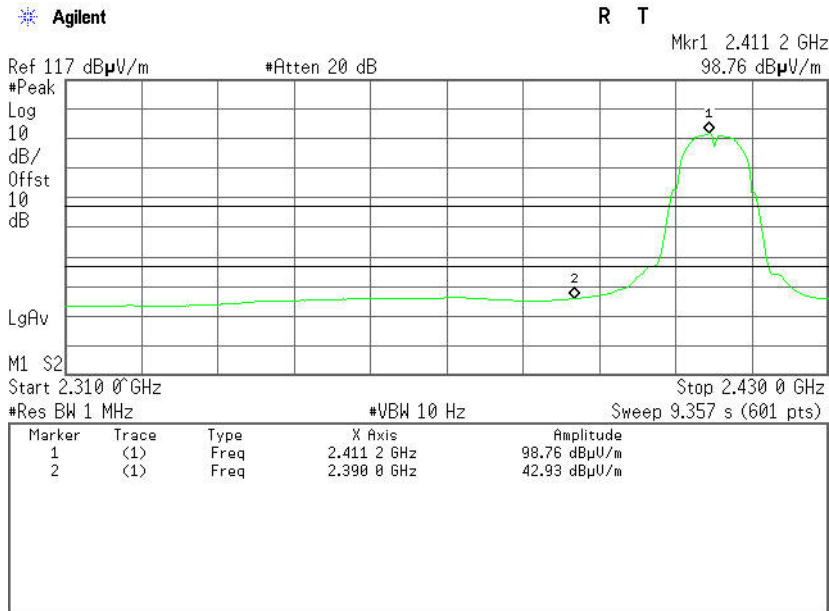

No.	Frequency (MHz)	Reading (dBuV)	Corrected (dB)	Result (dBuV)	Limit (dBuV)	Margin (dB)	Detector	Antenna Pole
1	2390.0000	48.18	-6.60	54.78	74.00	-19.22	Peak	Vertical
2	2390.0000	36.33	-6.60	42.93	54.00	-11.07	Average	Vertical



Detector mode: Peak

Polarity: Horizontal

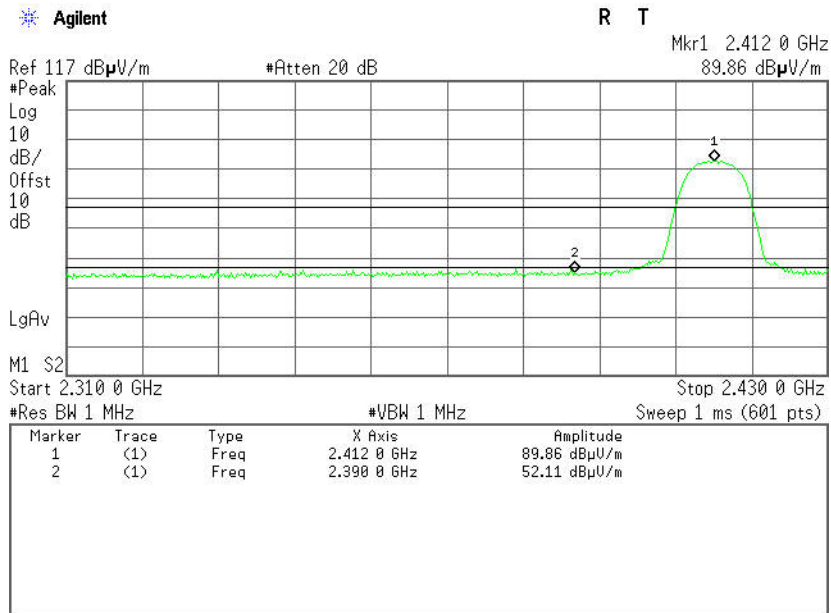

Detector mode: Average

Polarity: Horizontal

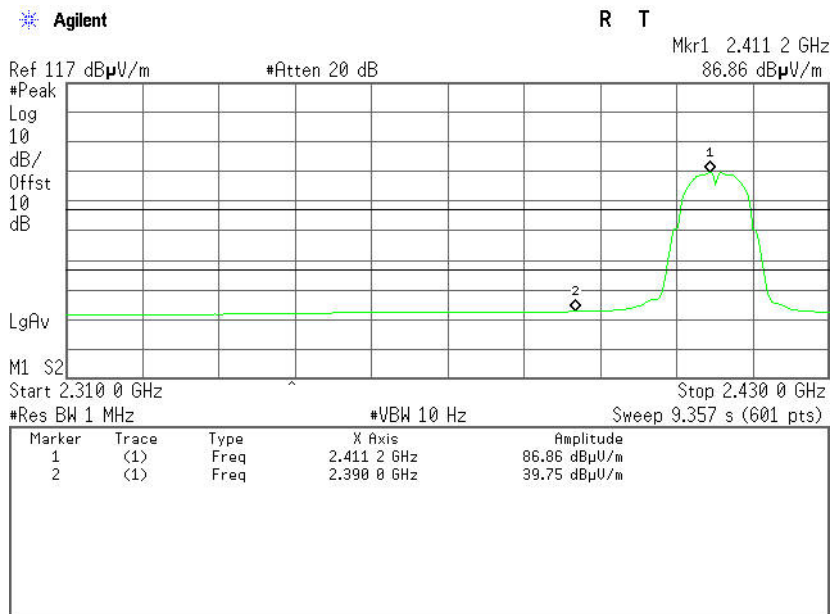

No.	Frequency (MHz)	Reading (dBuV)	Corrected (dB)	Result (dBuV)	Limit (dBuV)	Margin (dB)	Detector	Antenna Pole
1	2390.0000	45.51	-6.60	52.11	74.00	-21.89	Peak	Horizontal
2	2390.0000	33.15	-6.60	39.75	54.00	-14.25	Average	Horizontal



Band Edges (CH High)

Detector mode: Peak

Polarity: Vertical

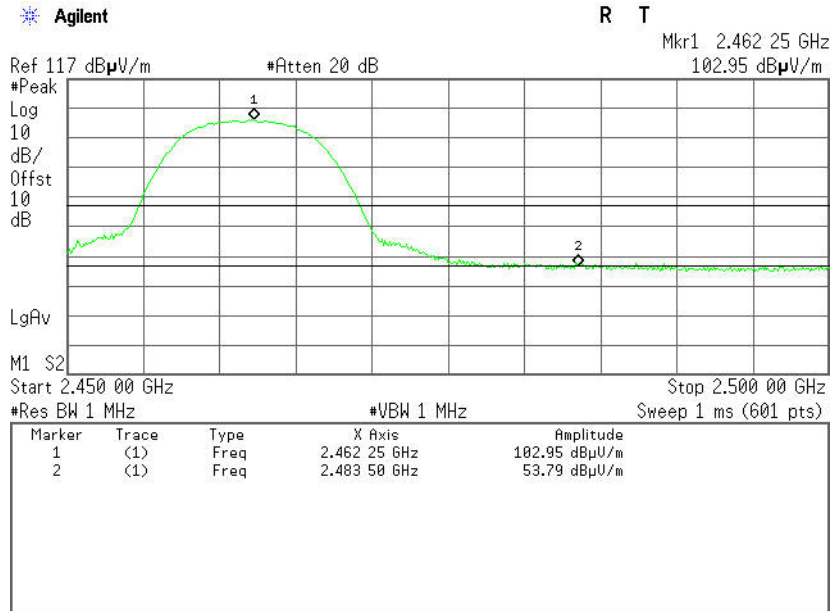

Detector mode: Average

Polarity: Vertical

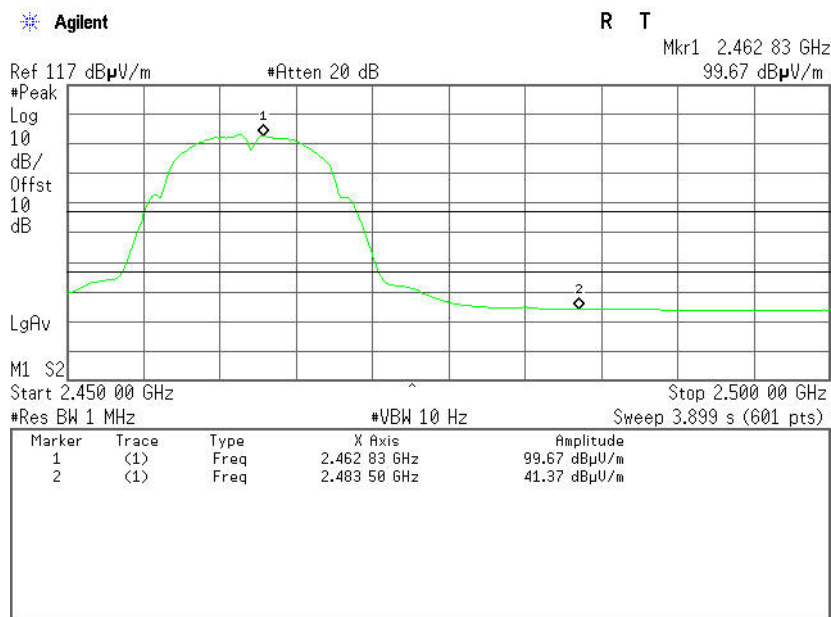

No.	Frequency (MHz)	Reading (dBuV)	Corrected (dB)	Result (dBuV)	Limit (dBuV)	Margin (dB)	Detector	Antenna Pole
1	2483.5000	47.55	-6.24	53.79	74.00	-20.21	Peak	Vertical
2	2483.5000	35.13	-6.24	41.37	54.00	-12.63	AVG	Vertical



Detector mode: Peak

Polarity: Horizontal

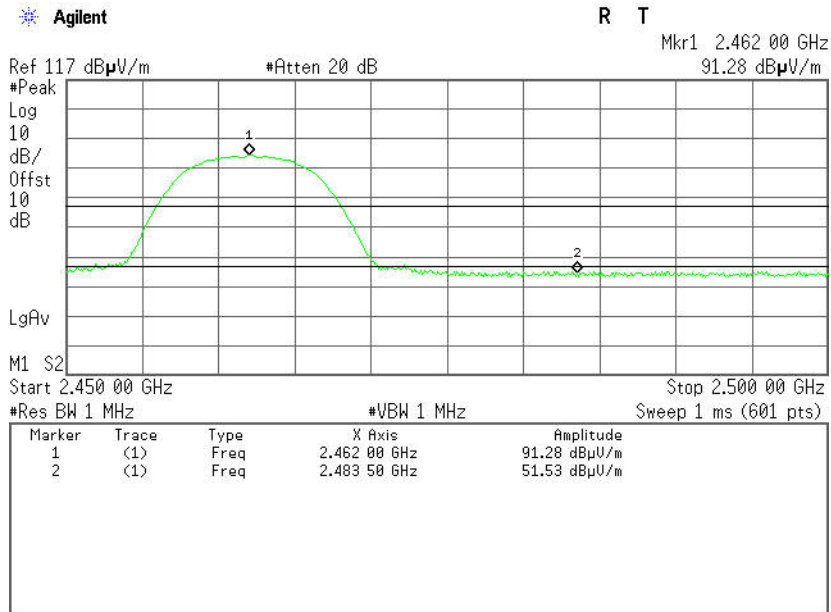

Detector mode: Average

Polarity: Horizontal

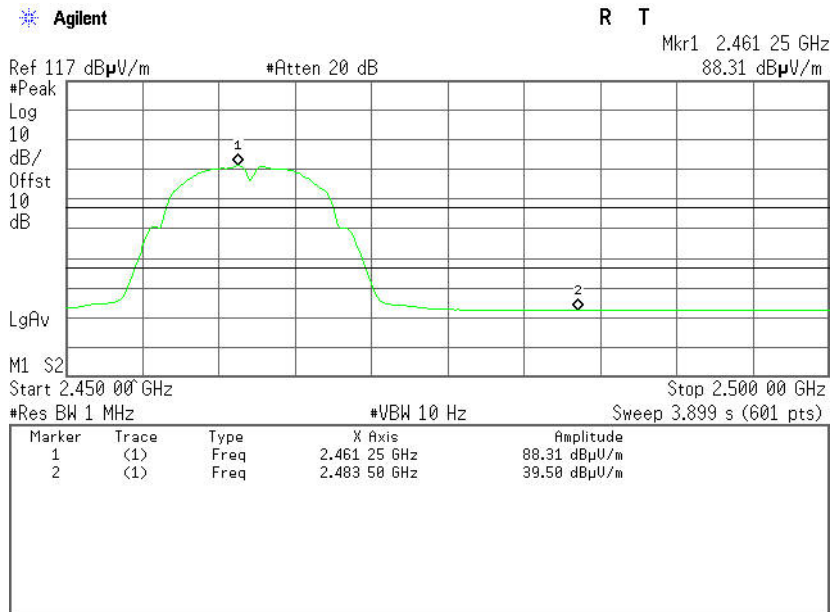

No.	Frequency (MHz)	Reading (dBuV)	Corrected (dB)	Result (dBuV)	Limit (dBuV)	Margin (dB)	Detector	Antenna Pole
1	2483.5000	45.29	-6.24	51.53	74.00	-22.47	Peak	Vertical
2	2483.5000	33.26	-6.24	39.50	54.00	-14.50	AVG	Vertical



IEEE 802.11b mode (Antenna 1)

Band Edges (CH Low)

Detector mode: Peak

Polarity: Vertical

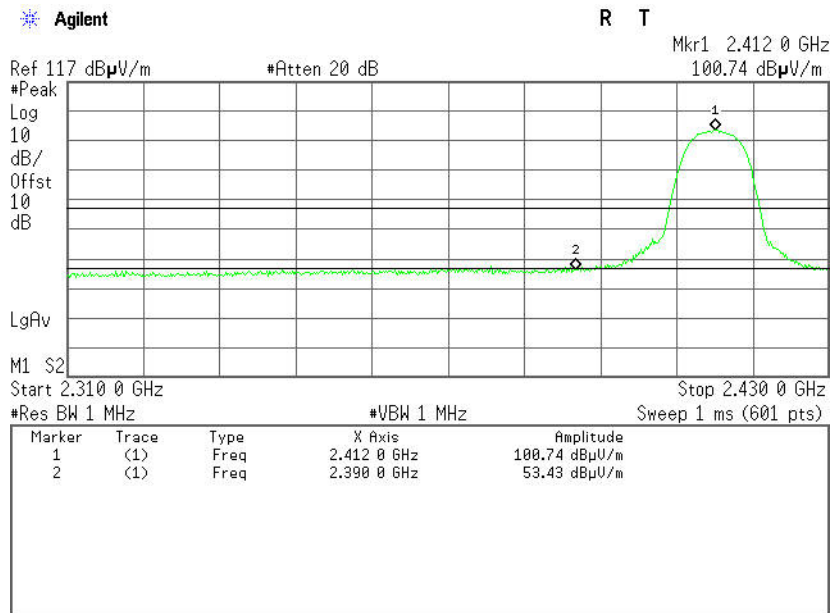

Detector mode: Average

Polarity: Vertical

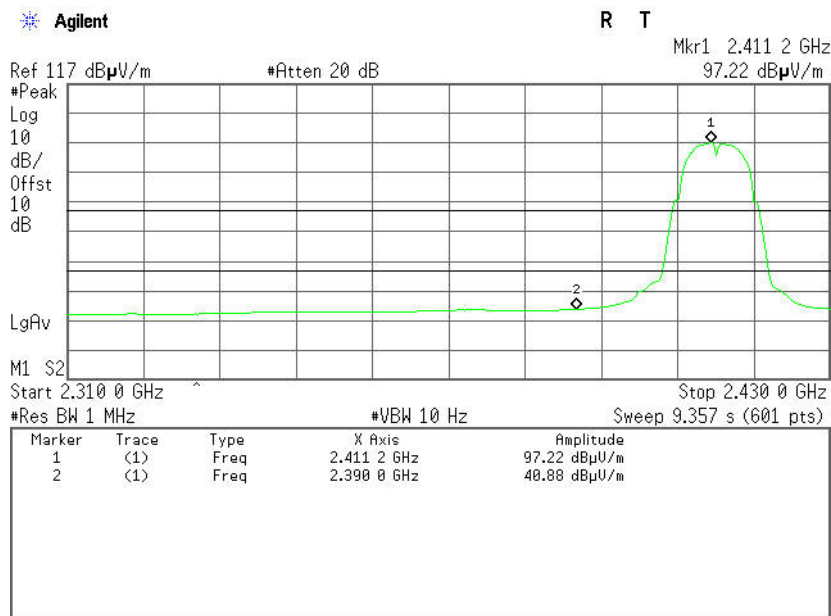

No.	Frequency (MHz)	Reading (dBuV)	Corrected (dB)	Result (dBuV)	Limit (dBuV)	Margin (dB)	Detector	Antenna Pole
1	2390.0000	46.83	-6.60	53.43	74.00	-20.57	Peak	Vertical
2	2390.0000	34.28	-6.60	40.88	54.00	-13.12	Average	Vertical



Detector mode: Peak

Polarity: Horizontal

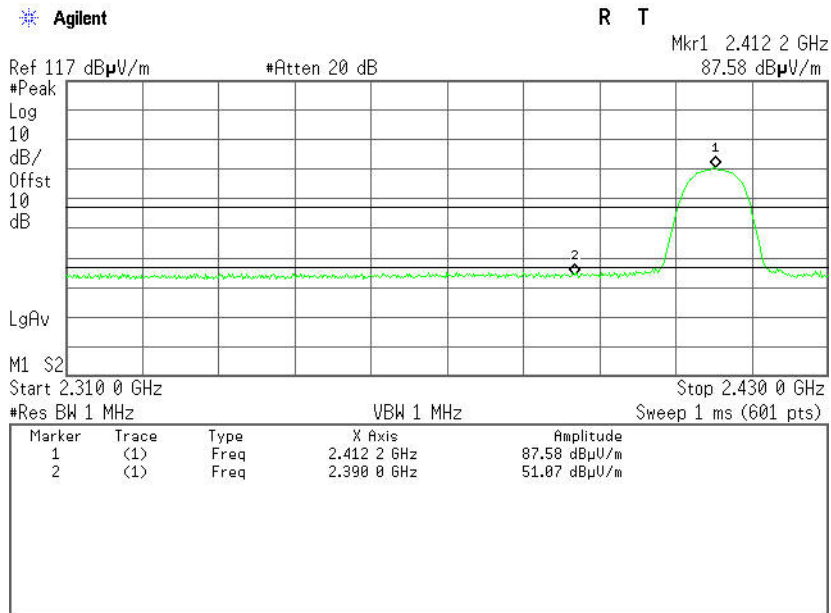

Detector mode: Average

Polarity: Horizontal

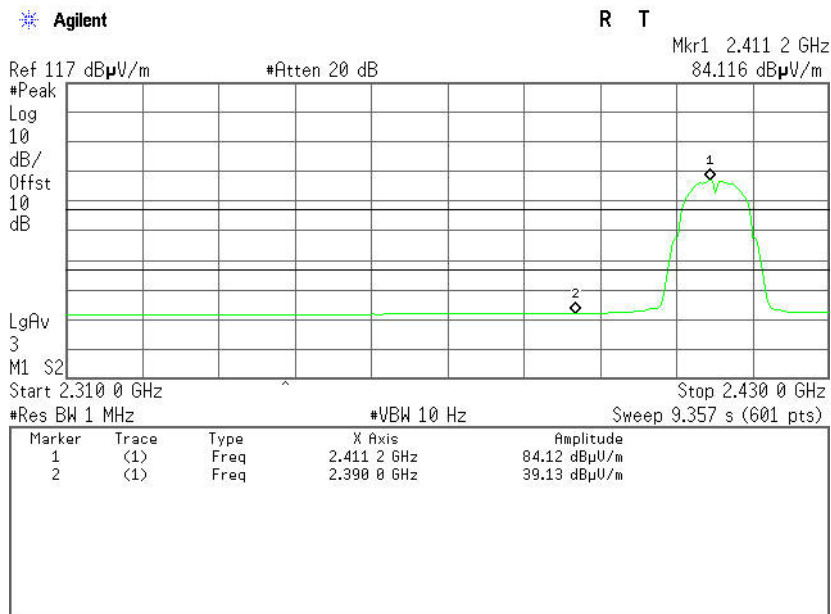

No.	Frequency (MHz)	Reading (dBuV)	Corrected (dB)	Result (dBuV)	Limit (dBuV)	Margin (dB)	Detector	Antenna Pole
1	2390.0000	44.47	-6.60	51.07	74.00	-22.93	Peak	Horizontal
2	2390.0000	32.53	-6.60	39.13	54.00	-14.87	Average	Horizontal



Band Edges (CH High)

Detector mode: Peak

Polarity: Vertical

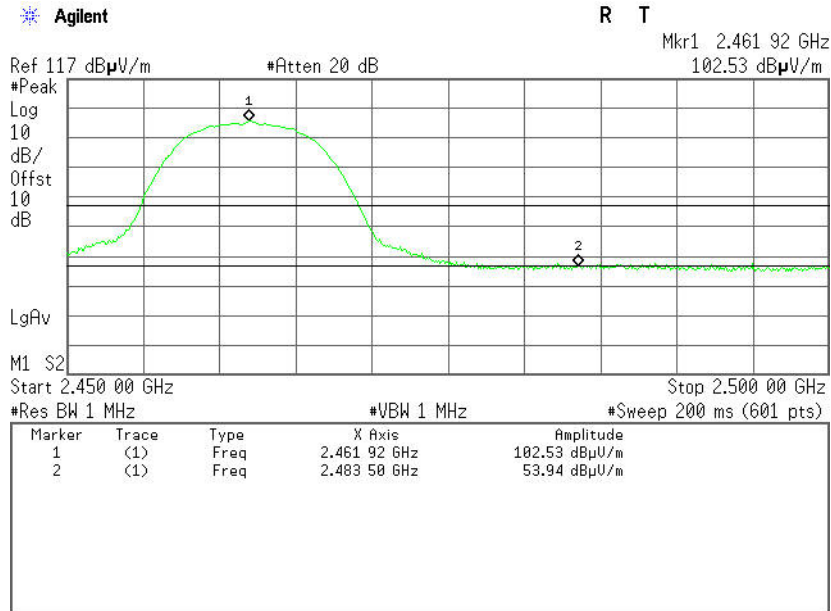

Detector mode: Average

Polarity: Vertical

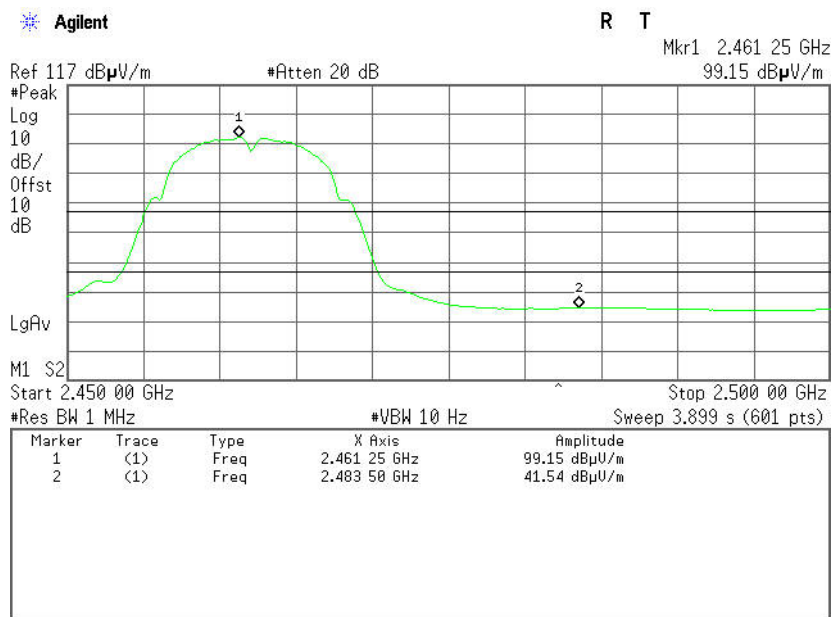

No.	Frequency (MHz)	Reading (dBuV)	Corrected (dB)	Result (dBuV)	Limit (dBuV)	Margin (dB)	Detector	Antenna Pole
1	2483.5000	47.70	-6.24	53.94	74.00	-20.06	Peak	Vertical
2	2483.5000	35.30	-6.24	41.54	54.00	-12.46	AVG	Vertical



Detector mode: Peak

Polarity: Horizontal

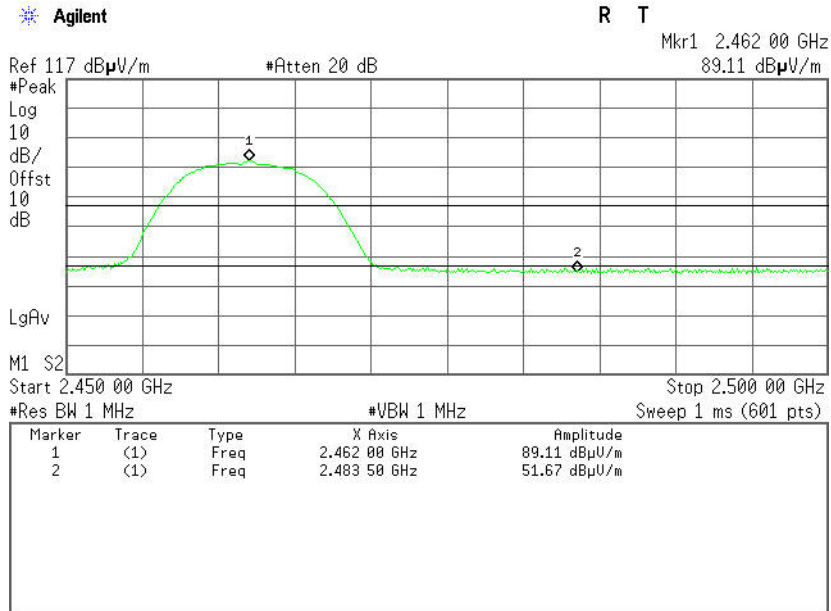

Detector mode: Average

Polarity: Horizontal

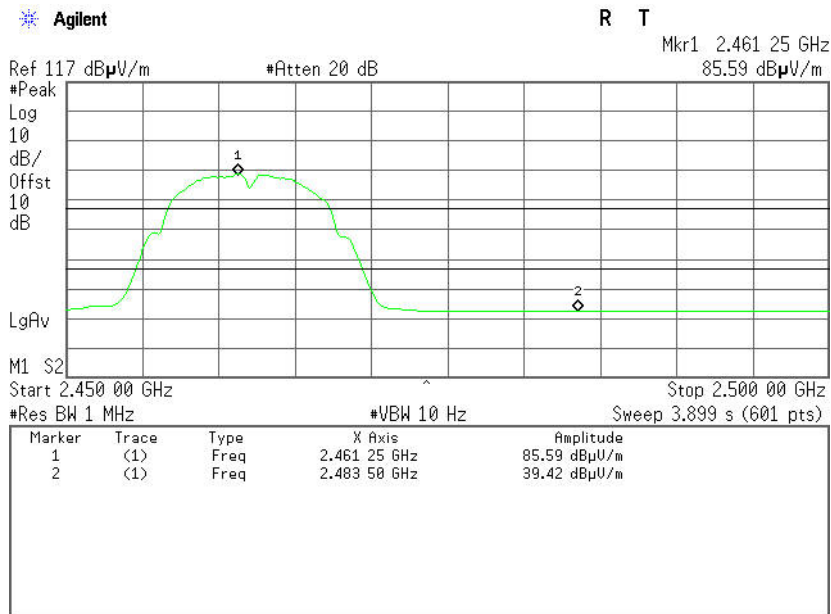

No.	Frequency (MHz)	Reading (dBuV)	Corrected (dB)	Result (dBuV)	Limit (dBuV)	Margin (dB)	Detector	Antenna Pole
1	2483.5000	45.43	-6.24	51.67	74.00	-22.33	Peak	Vertical
2	2483.5000	33.18	-6.24	39.42	54.00	-14.58	AVG	Vertical



IEEE 802.11g mode (Antenna 0)

Band Edges (CH Low)

Detector mode: Peak

Polarity: Vertical

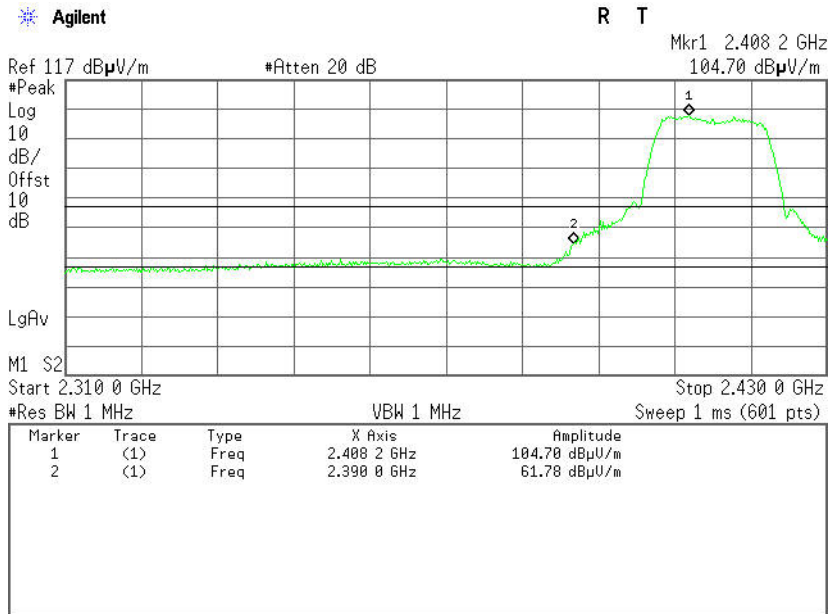

Detector mode: Average

Polarity: Vertical

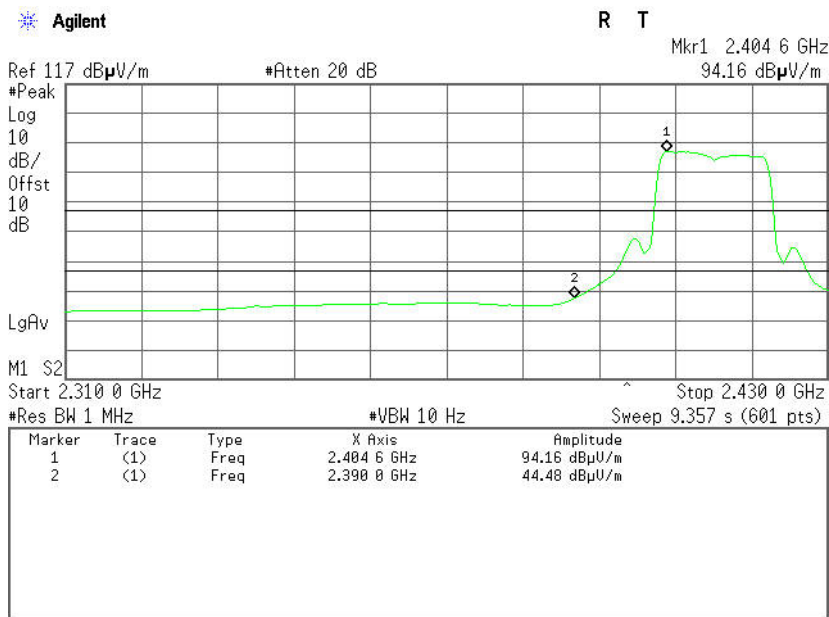

No.	Frequency (MHz)	Reading (dBuV)	Corrected (dB)	Result (dBuV)	Limit (dBuV)	Margin (dB)	Detector	Antenna Pole
1	2390.0000	55.18	-6.60	61.78	74.00	-12.22	Peak	Vertical
2	2390.0000	37.88	-6.60	44.48	54.00	-9.52	Average	Vertical



Detector mode: Peak

Polarity: Horizontal

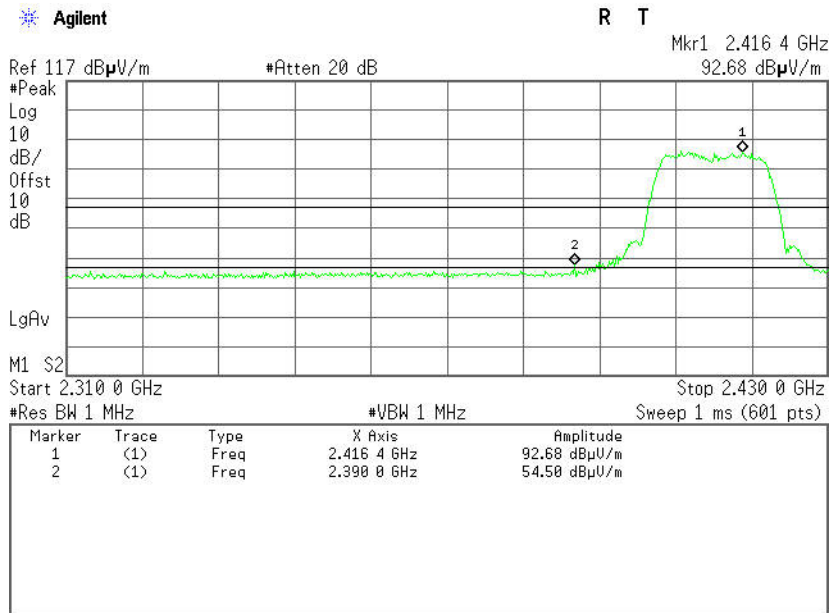

Detector mode: Average

Polarity: Horizontal

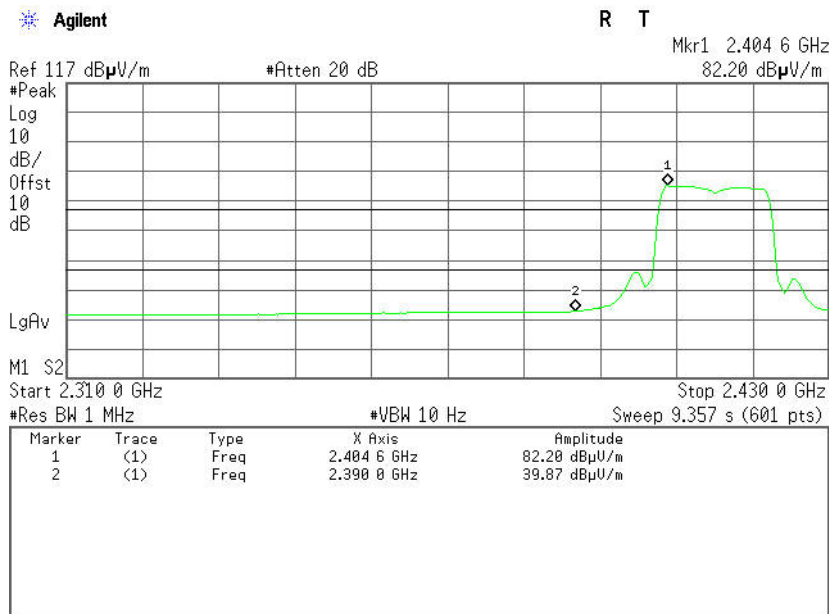

No.	Frequency (MHz)	Reading (dBuV)	Corrected (dB)	Result (dBuV)	Limit (dBuV)	Margin (dB)	Detector	Antenna Pole
1	2390.0000	47.90	-6.60	54.50	74.00	-19.50	Peak	Horizontal
2	2390.0000	33.27	-6.60	39.87	54.00	-14.13	Average	Horizontal



Band Edges (CH High)

Detector mode: Peak

Polarity: Vertical

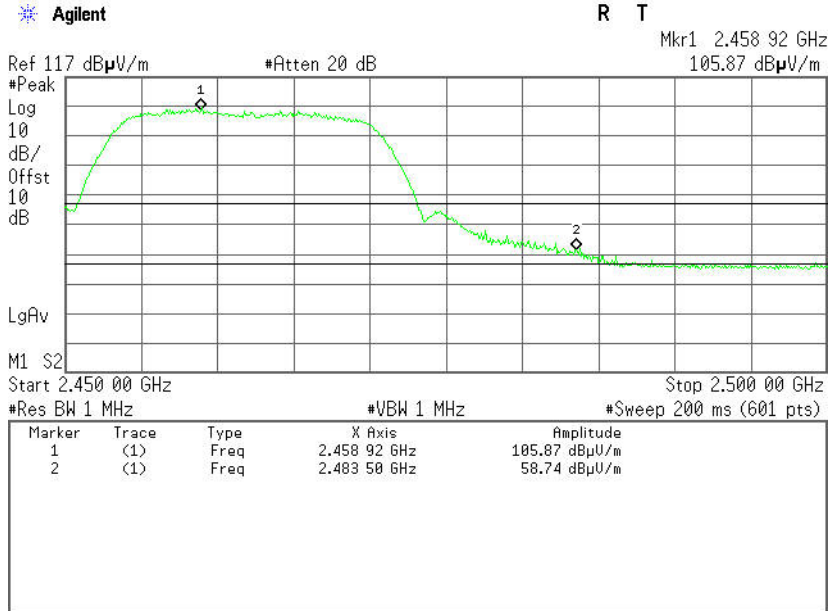

Detector mode: Average

Polarity: Vertical

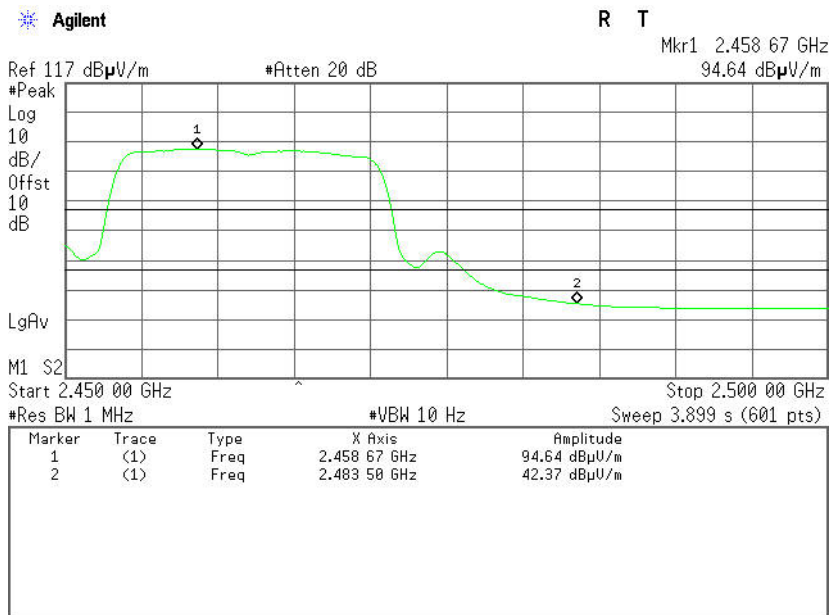

No.	Frequency (MHz)	Reading (dBuV)	Corrected (dB)	Result (dBuV)	Limit (dBuV)	Margin (dB)	Detector	Antenna Pole
1	2483.5000	52.50	-6.24	58.74	74.00	-15.26	Peak	Vertical
2	2483.5000	36.13	-6.24	42.37	54.00	-11.63	AVG	Vertical



Detector mode: Peak

Polarity: Horizontal

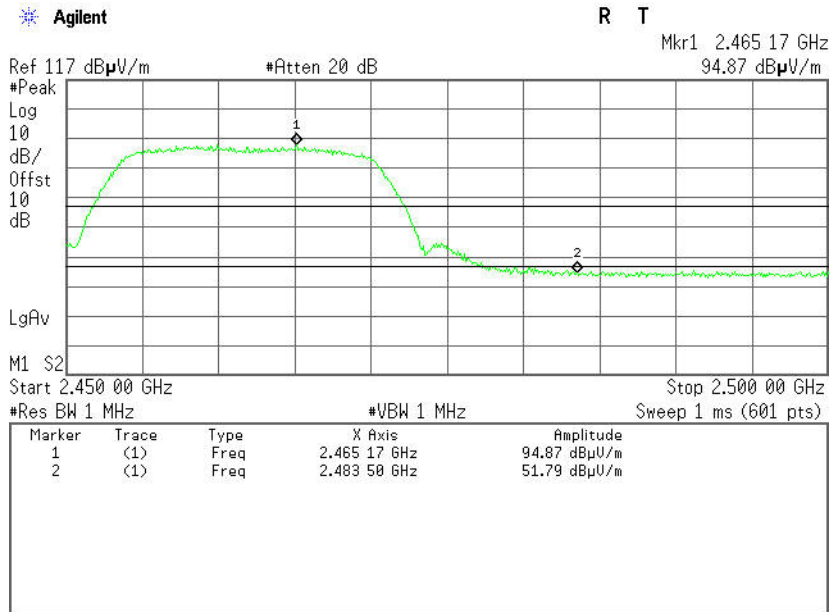

Detector mode: Average

Polarity: Horizontal

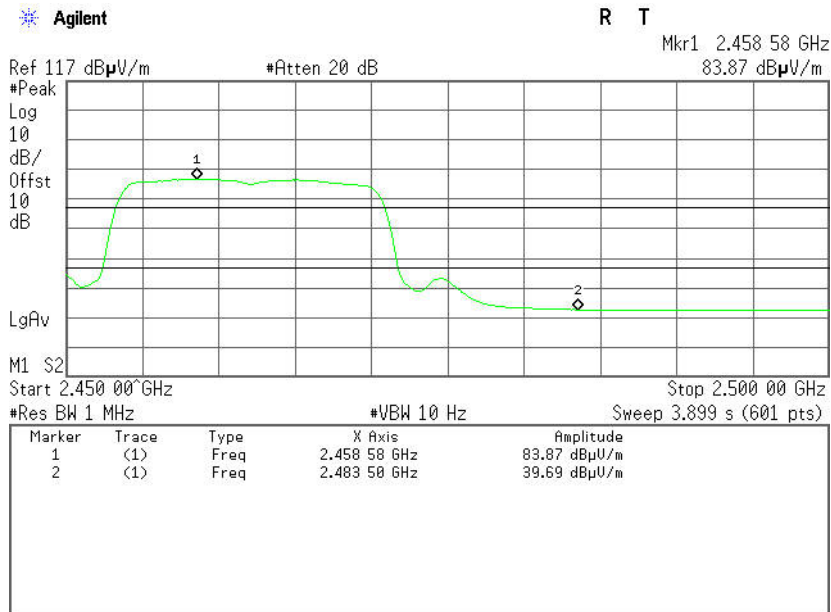

No.	Frequency (MHz)	Reading (dBuV)	Corrected (dB)	Result (dBuV)	Limit (dBuV)	Margin (dB)	Detector	Antenna Pole
1	2483.5000	45.55	-6.24	51.79	74.00	-22.21	Peak	Horizontal
2	2483.5000	33.45	-6.24	39.69	54.00	-14.31	AVG	Horizontal



IEEE 802.11g mode (Antenna 1)

Band Edges (CH Low)

Detector mode: Peak

Polarity: Vertical

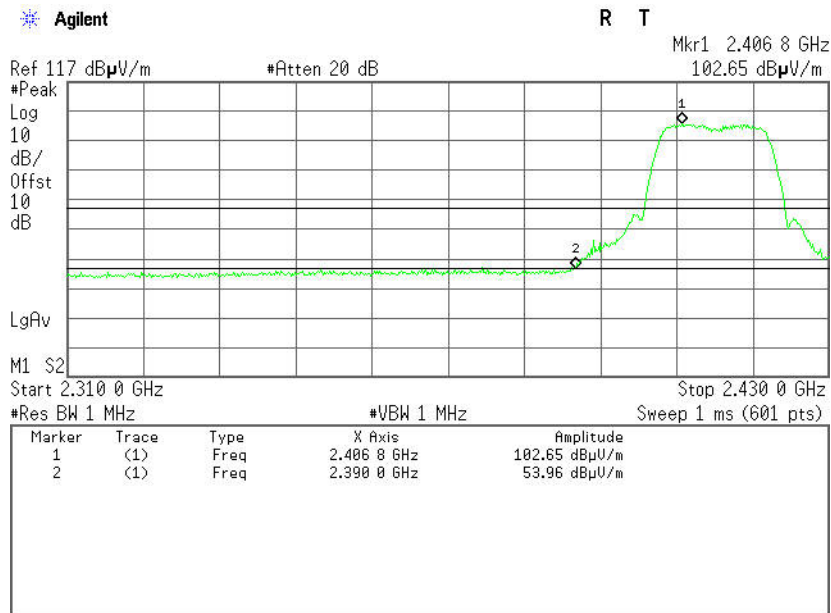

Detector mode: Average

Polarity: Vertical

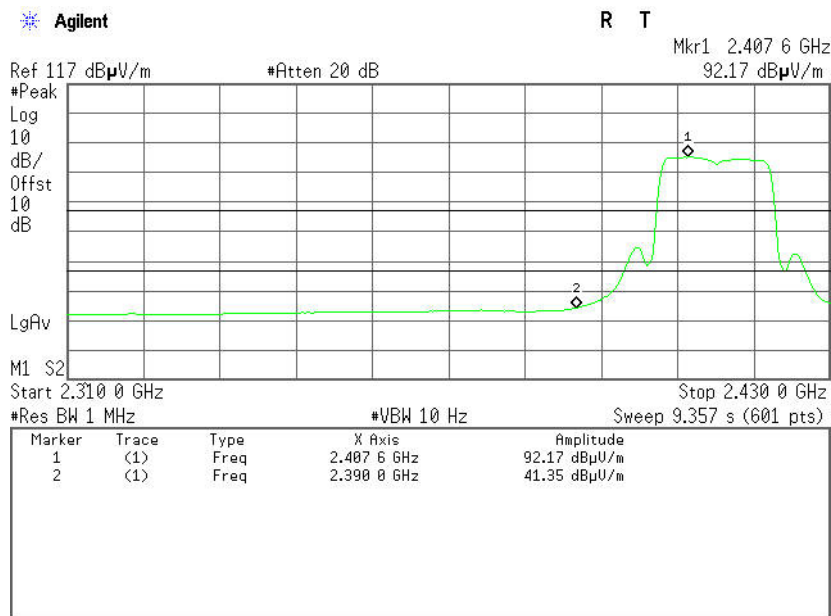

No.	Frequency (MHz)	Reading (dBuV)	Corrected (dB)	Result (dBuV)	Limit (dBuV)	Margin (dB)	Detector	Antenna Pole
1	2390.0000	47.36	-6.60	53.96	74.00	-20.04	Peak	Vertical
2	2390.0000	34.75	-6.60	41.35	54.00	-12.65	Average	Vertical



Detector mode: Peak

Polarity: Horizontal

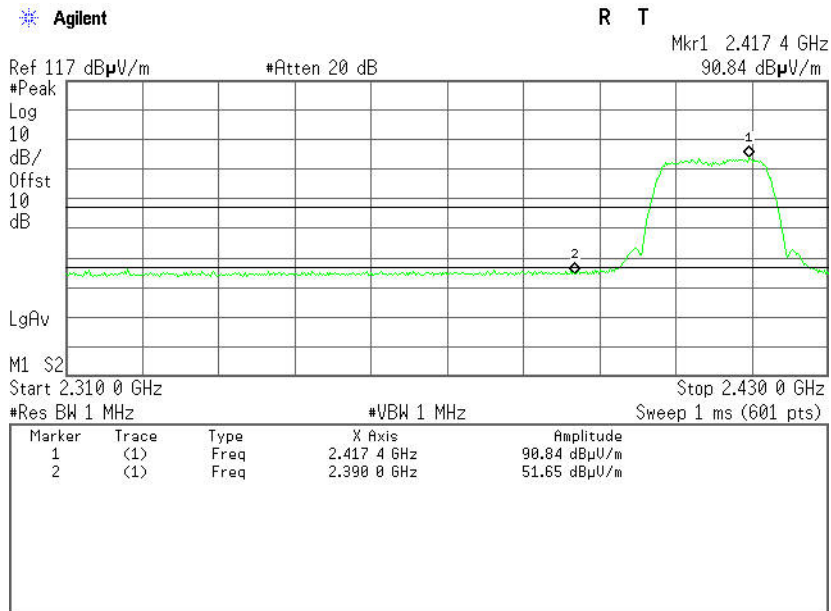

Detector mode: Average

Polarity: Horizontal

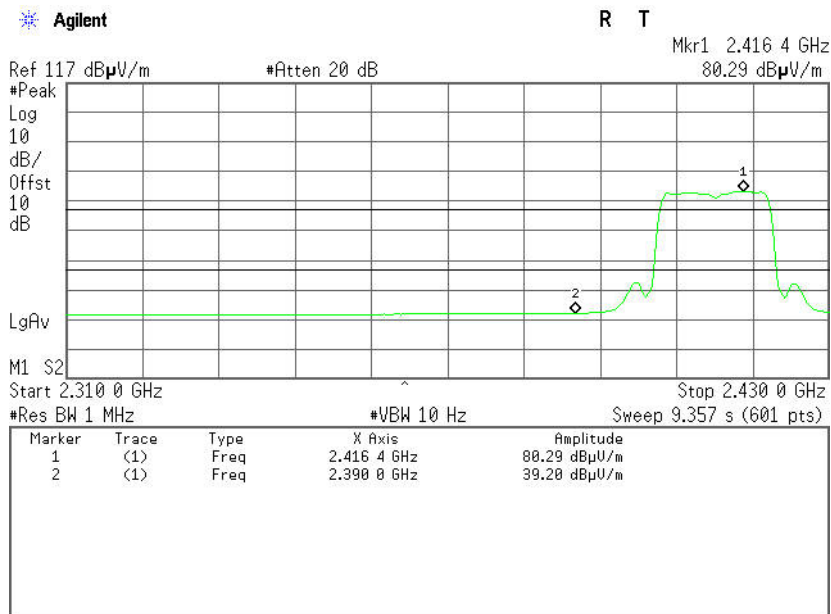

No.	Frequency (MHz)	Reading (dBuV)	Corrected (dB)	Result (dBuV)	Limit (dBuV)	Margin (dB)	Detector	Antenna Pole
1	2390.0000	45.05	-6.60	51.65	74.00	-22.35	Peak	Horizontal
2	2390.0000	32.60	-6.60	39.20	54.00	-14.80	Average	Horizontal



Band Edges (CH High)

Detector mode: Peak

Polarity: Vertical

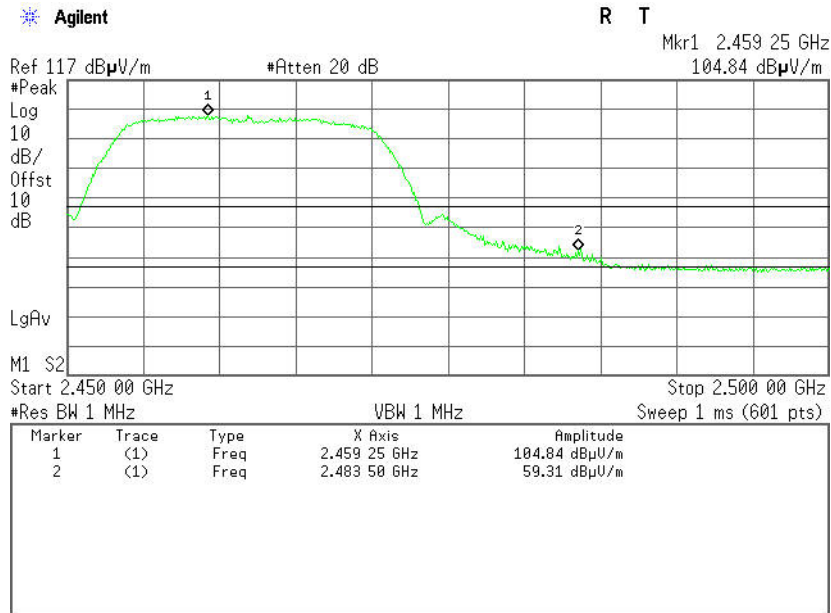

Detector mode: Average

Polarity: Vertical

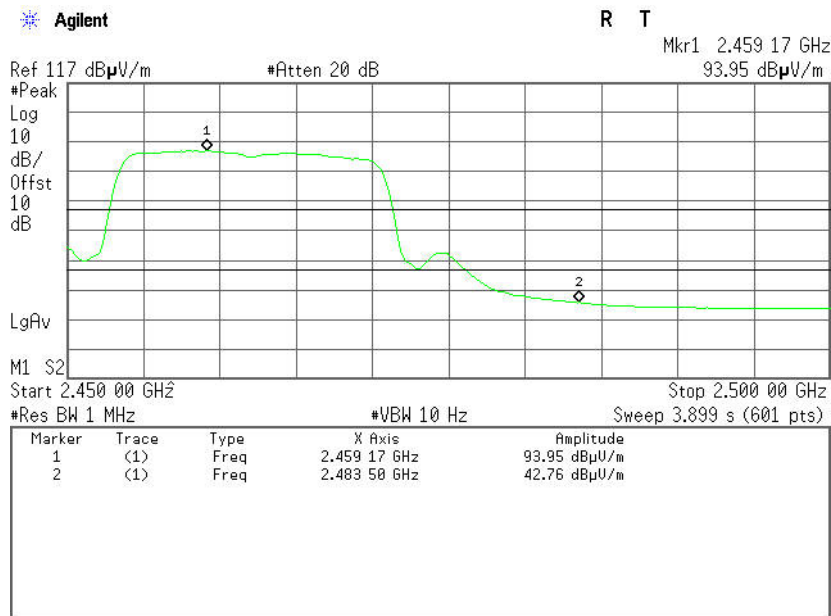

No.	Frequency (MHz)	Reading (dB μ V)	Corrected (dB)	Result (dB μ V)	Limit (dB μ V)	Margin (dB)	Detector	Antenna Pole
1	2483.5000	53.07	-6.24	59.31	74.00	-14.69	Peak	Vertical
2	2483.5000	36.52	-6.24	42.76	54.00	-11.24	AVG	Vertical



Detector mode: Peak

Polarity: Horizontal

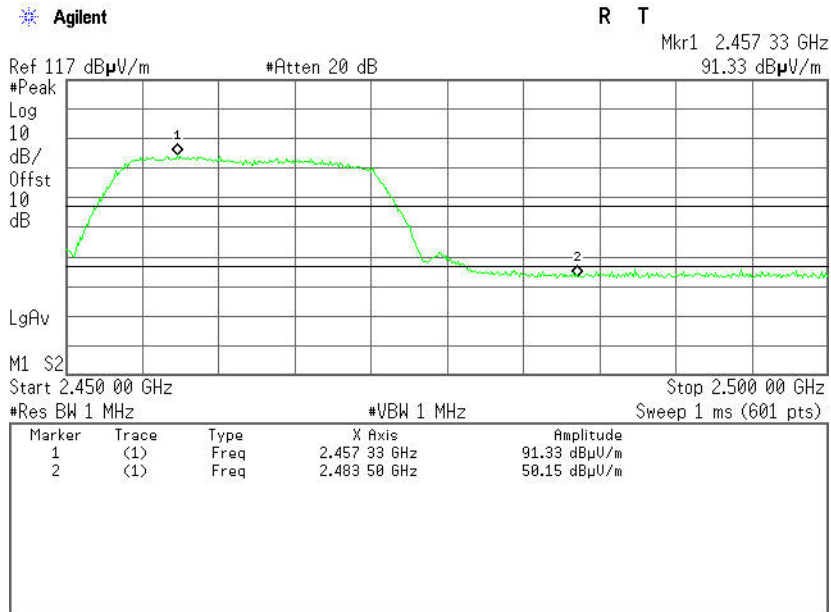

Detector mode: Average

Polarity: Horizontal

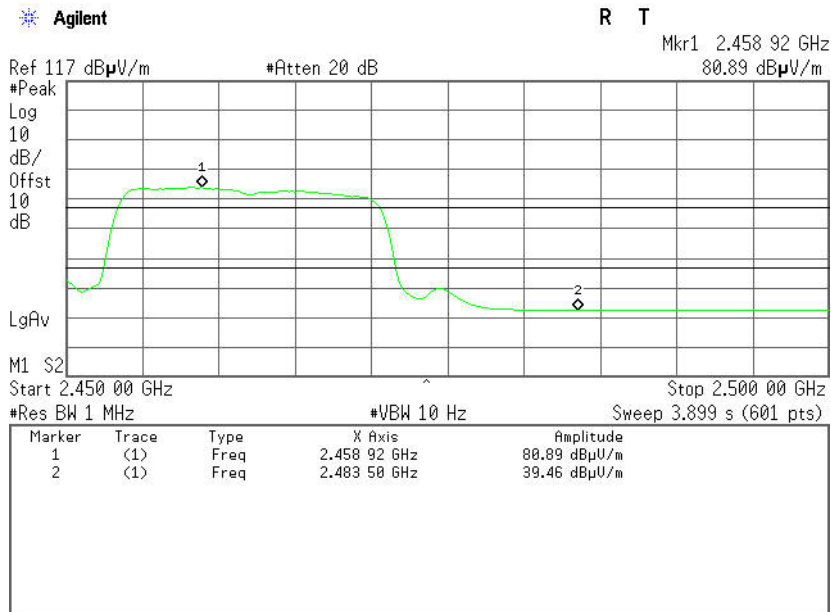

No.	Frequency (MHz)	Reading (dBuV)	Corrected (dB)	Result (dBuV)	Limit (dBuV)	Margin (dB)	Detector	Antenna Pole
1	2483.5000	43.91	-6.24	50.15	74.00	-23.85	Peak	Horizontal
2	2483.5000	33.22	-6.24	39.46	54.00	-14.54	AVG	Horizontal



IEEE 802.11n HT20 MHz mode (Combine with Antenna 0 and Antenna 1)

Band Edges (CH Low)

Detector mode: Peak

Polarity: Vertical

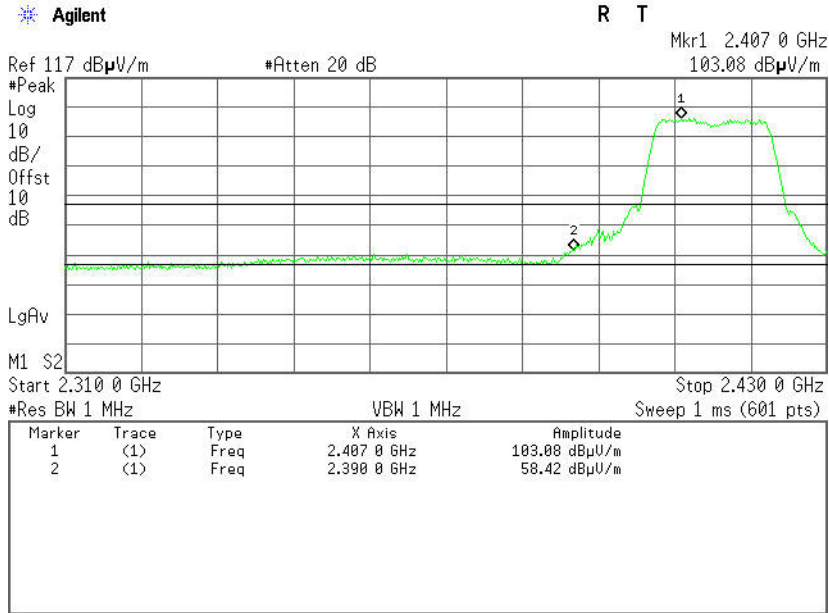

Detector mode: Average

Polarity: Vertical

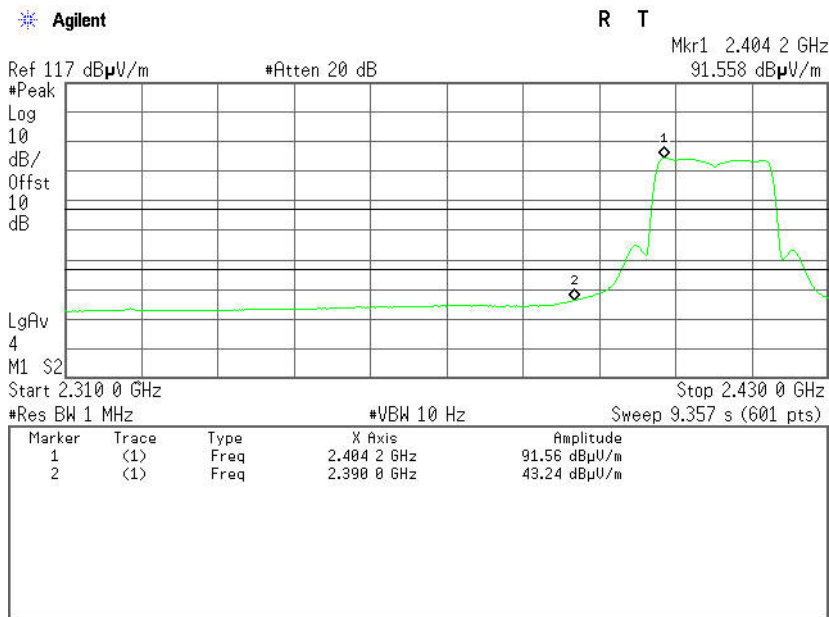

No.	Frequency (MHz)	Reading (dBuV)	Corrected (dB)	Result (dBuV)	Limit (dBuV)	Margin (dB)	Detector	Antenna Pole
1	2390.0000	51.82	-6.60	58.42	74.00	-15.58	Peak	Vertical
2	2390.0000	36.64	-6.60	43.24	54.00	-10.76	Average	Vertical



Detector mode: Peak

Polarity: Horizontal

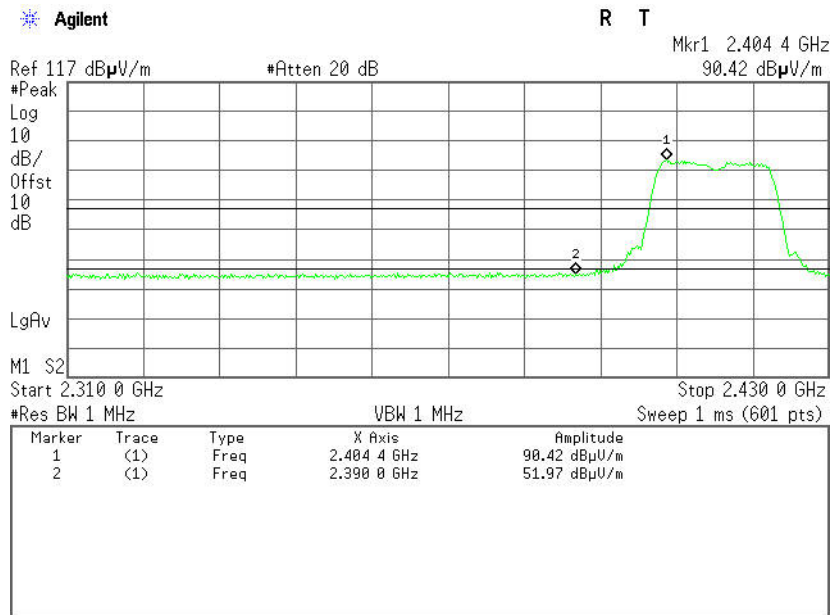

Detector mode: Average

Polarity: Horizontal

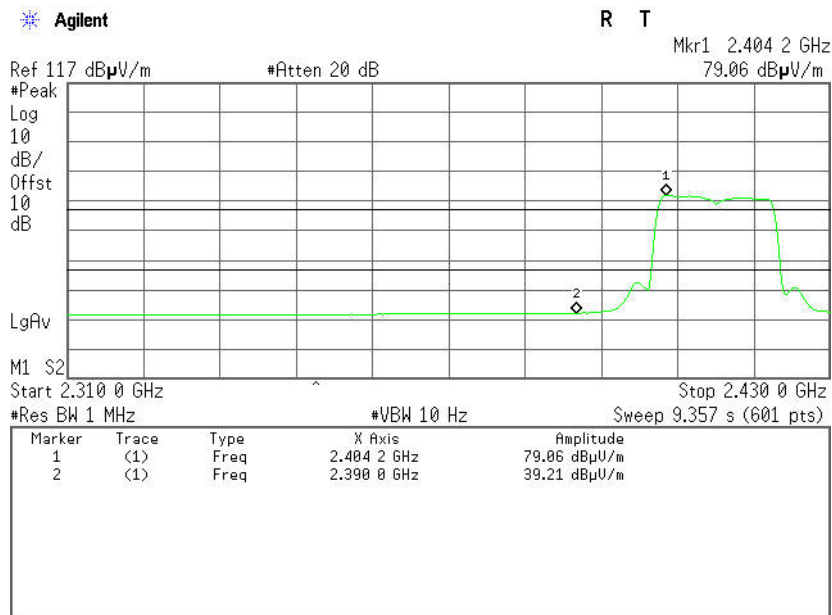

No.	Frequency (MHz)	Reading (dBuV)	Corrected (dB)	Result (dBuV)	Limit (dBuV)	Margin (dB)	Detector	Antenna Pole
1	2390.0000	45.37	-6.60	51.97	74.00	-22.03	Peak	Horizontal
2	2390.0000	32.61	-6.60	39.21	54.00	-14.79	Average	Horizontal



Band Edges (CH High)

Detector mode: Peak

Polarity: Vertical

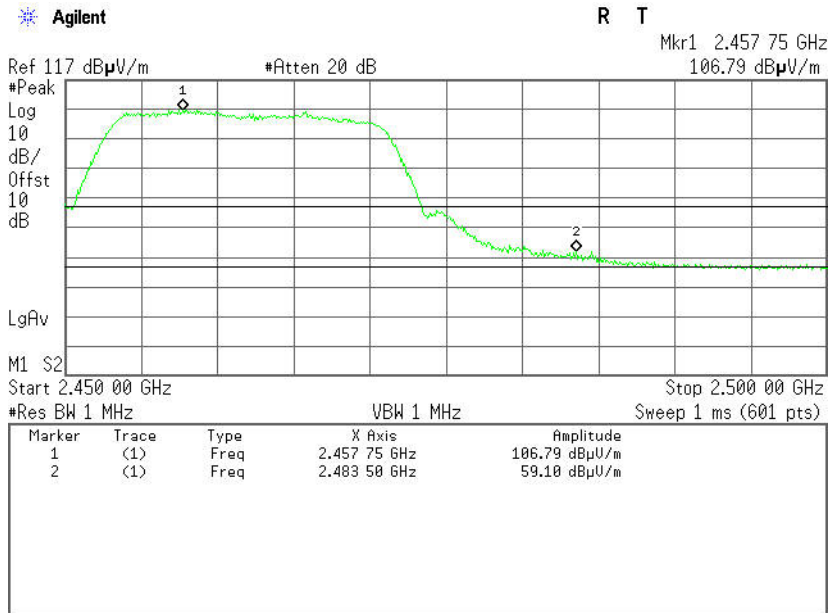

Detector mode: Average

Polarity: Vertical

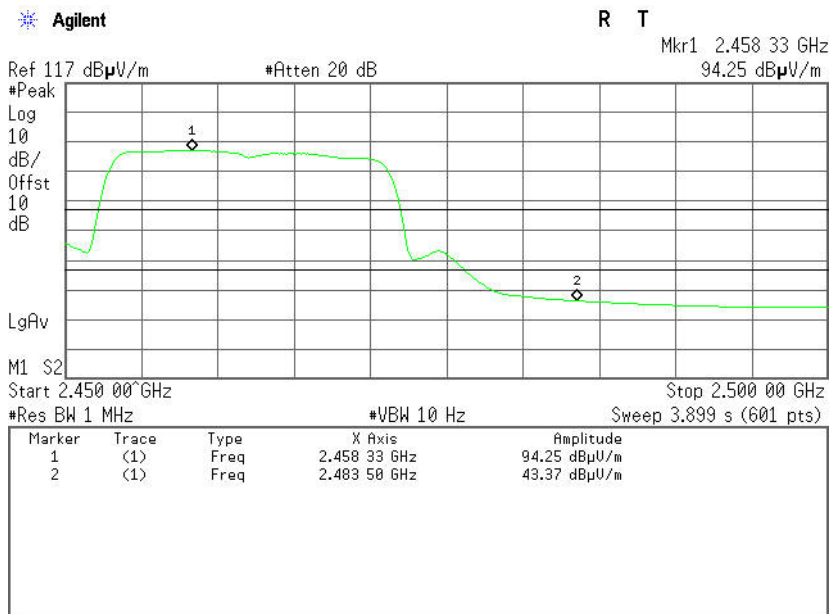

No.	Frequency (MHz)	Reading (dBuV)	Corrected (dB)	Result (dBuV)	Limit (dBuV)	Margin (dB)	Detector	Antenna Pole
1	2483.5000	52.86	-6.24	59.10	74.00	-14.90	Peak	Vertical
2	2483.5000	37.13	-6.24	43.37	54.00	-10.63	AVG	Vertical



Detector mode: Peak

Polarity: Horizontal

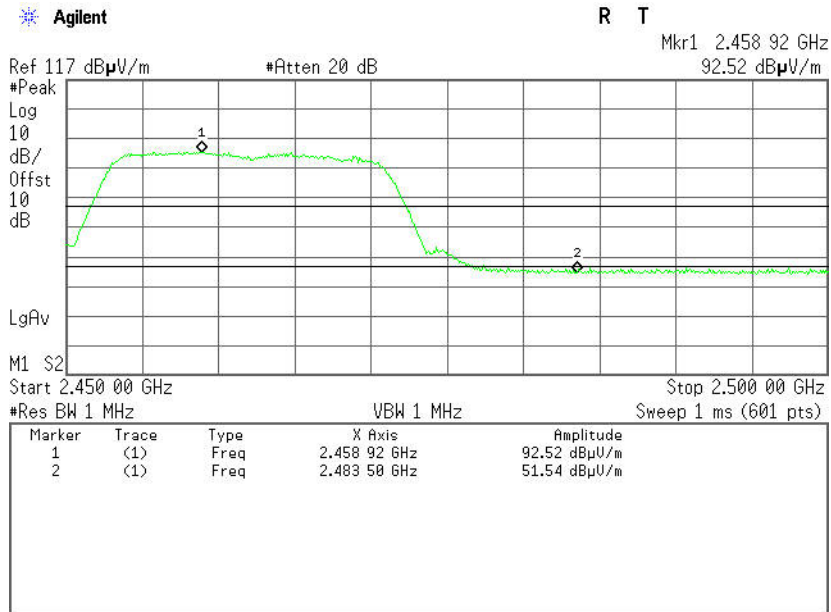

Detector mode: Average

Polarity: Horizontal

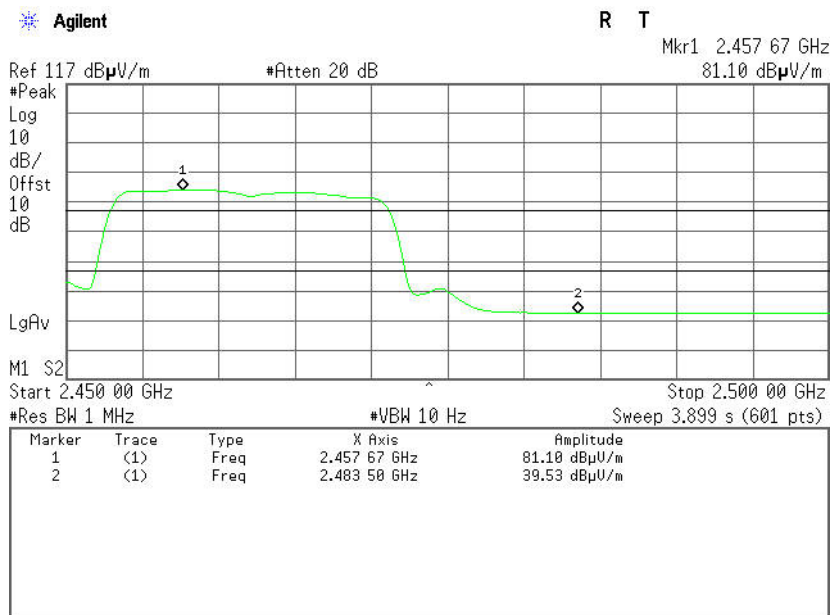

No.	Frequency (MHz)	Reading (dBuV)	Corrected (dB)	Result (dBuV)	Limit (dBuV)	Margin (dB)	Detector	Antenna Pole
1	2483.5000	45.30	-6.24	51.54	74.00	-22.46	Peak	Horizontal
2	2483.5000	33.29	-6.24	39.53	54.00	-14.47	AVG	Horizontal



**IEEE 802.11n HT40 MHz mode(Combine with Antenna 0 and Antenna 1)
Band Edges (CH Low)**

Detector mode: Peak

Polarity: Vertical

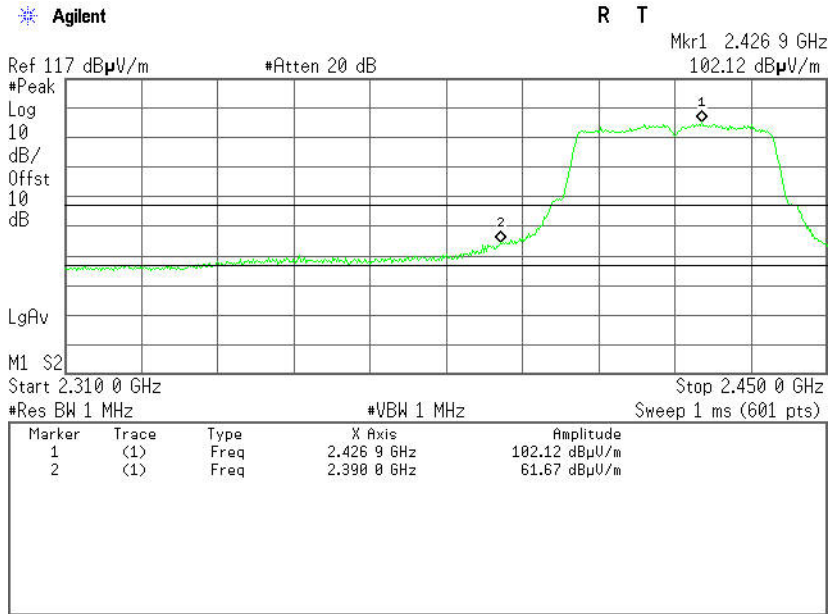

Detector mode: Average

Polarity: Vertical

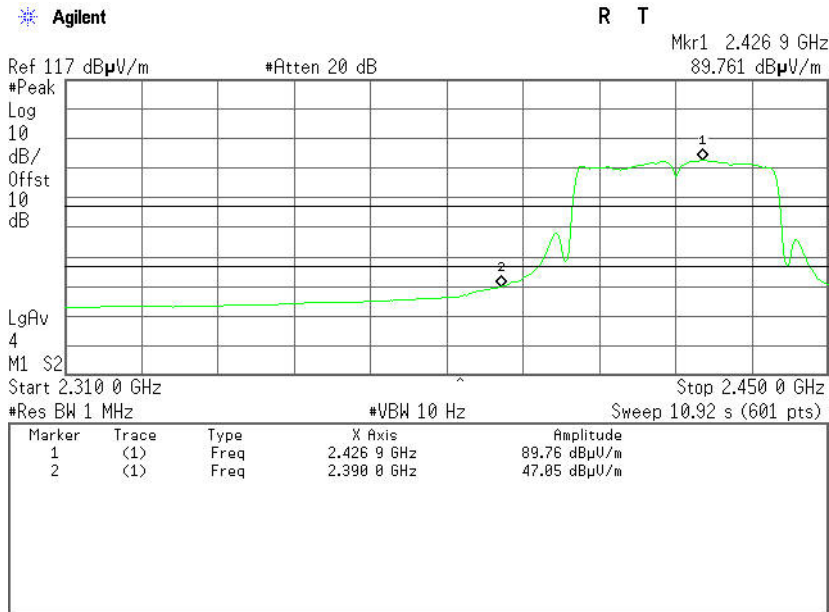

No.	Frequency (MHz)	Reading (dB μ V)	Corrected (dB)	Result (dB μ V)	Limit (dB μ V)	Margin (dB)	Detector	Antenna Pole
1	2390.0000	55.07	-6.60	61.67	74.00	-12.33	Peak	Vertical
2	2390.0000	40.45	-6.60	47.05	54.00	-6.95	Average	Vertical



Detector mode: Peak

Polarity: Horizontal

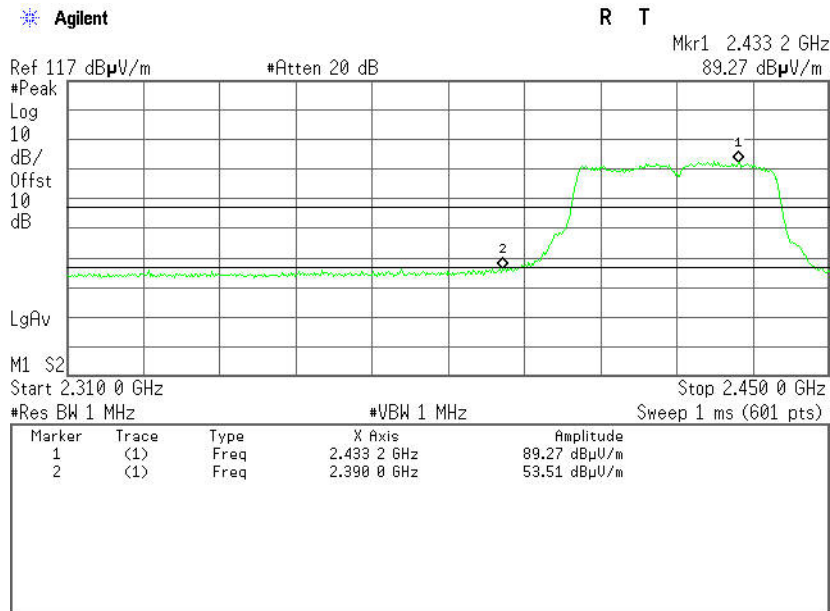

Detector mode: Average

Polarity: Horizontal

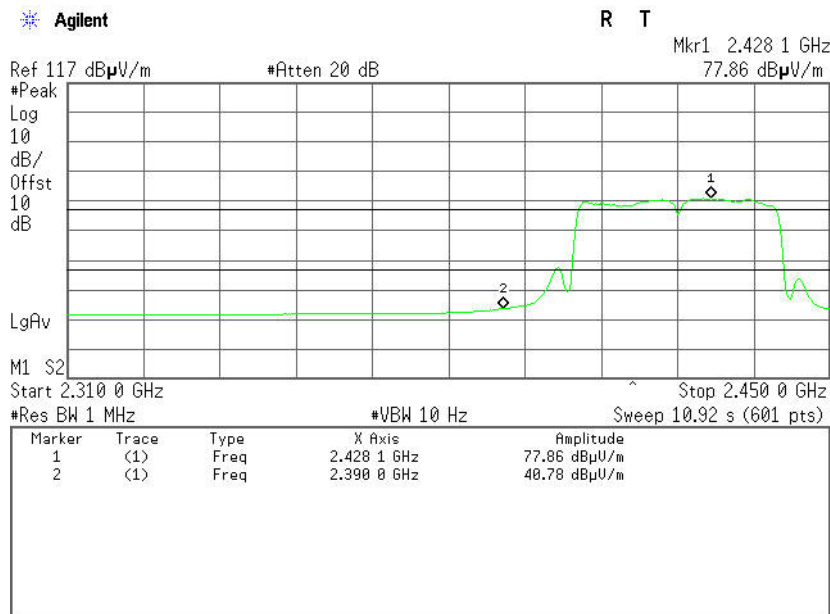

No.	Frequency (MHz)	Reading (dBuV)	Corrected (dB)	Result (dBuV)	Limit (dBuV)	Margin (dB)	Detector	Antenna Pole
1	2390.0000	46.91	-6.60	53.51	74.00	-20.49	Peak	Horizontal
2	2390.0000	34.18	-6.60	40.78	54.00	-13.22	Average	Horizontal



Band Edges (CH High)

Detector mode: Peak

Polarity: Vertical

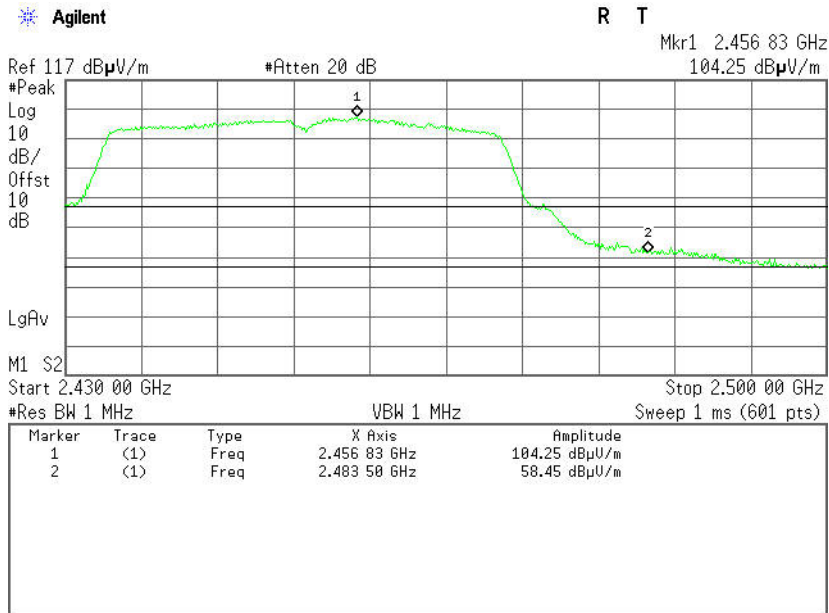

Detector mode: Average

Polarity: Vertical

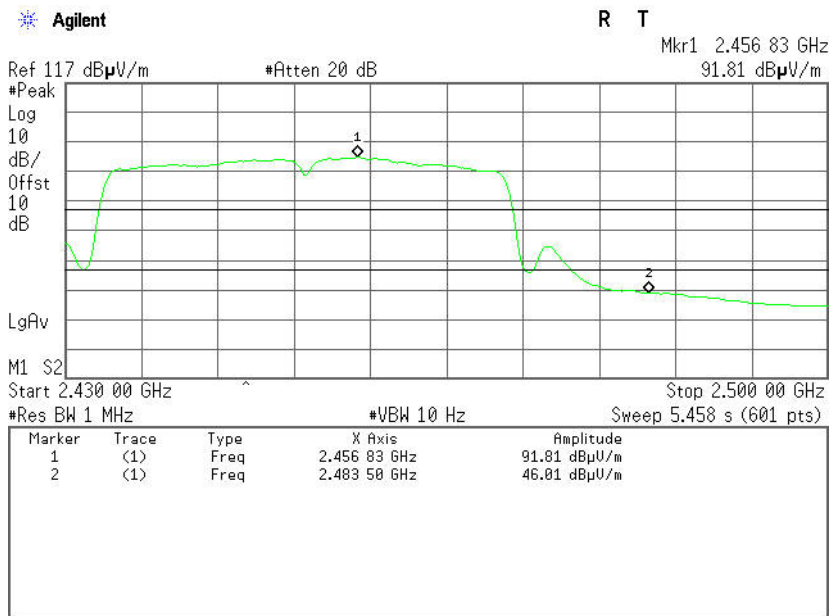

No.	Frequency (MHz)	Reading (dBuV)	Corrected (dB)	Result (dBuV)	Limit (dBuV)	Margin (dB)	Detector	Antenna Pole
1	2483.5000	52.21	-6.24	58.45	74.00	-15.55	Peak	Vertical
2	2483.5000	39.77	-6.24	46.01	54.00	-7.99	AVG	Vertical



Detector mode: Peak

Polarity: Horizontal

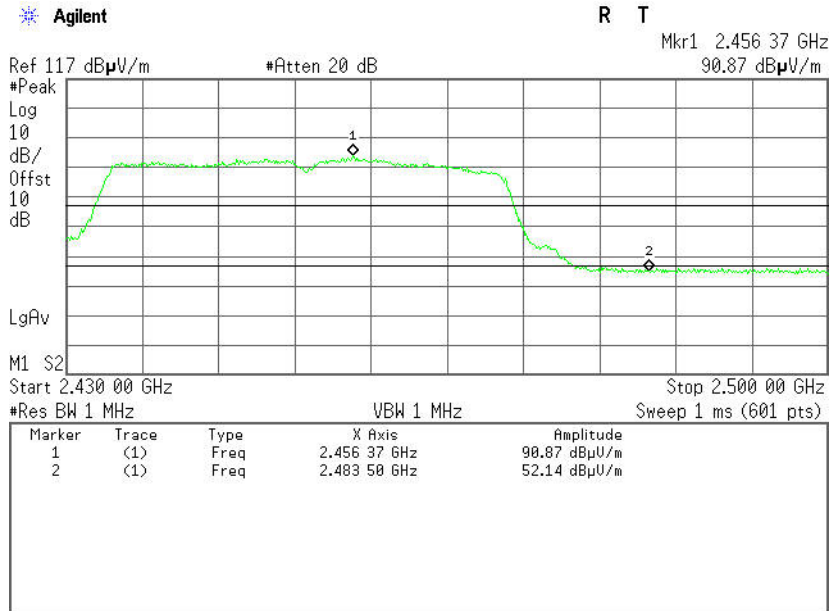

Detector mode: Average

Polarity: Horizontal

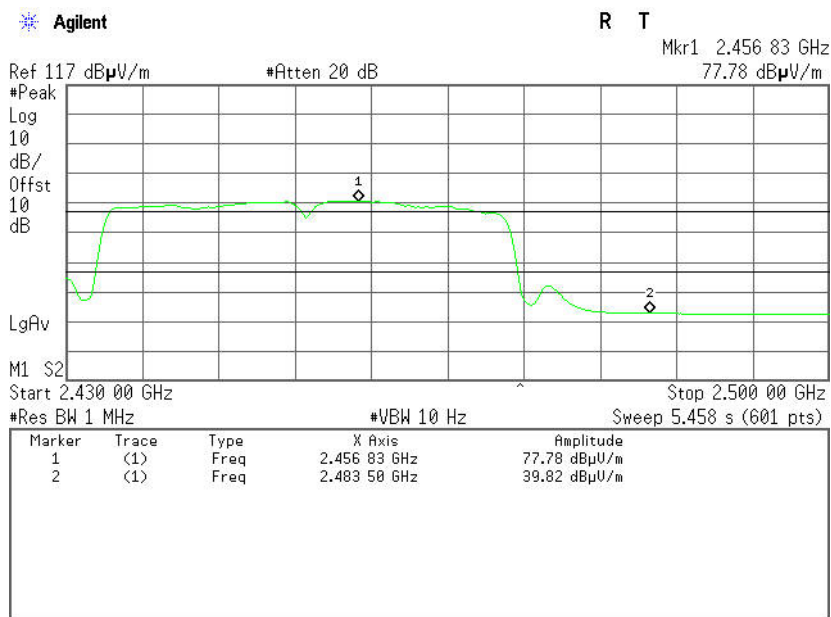

No.	Frequency (MHz)	Reading (dBuV)	Corrected (dB)	Result (dBuV)	Limit (dBuV)	Margin (dB)	Detector	Antenna Pole
1	2483.5000	45.90	-6.24	52.14	74.00	-21.86	Peak	Horizontal
2	2483.5000	33.58	-6.24	39.82	54.00	-14.18	AVG	Horizontal



7.6. PEAK POWER SPECTRAL DENSITY MEASUREMENT

7.6.1. LIMITS

According to §15.247(e), for digitally modulated systems, the power spectral density conducted from the intentional radiator to the antenna shall not be greater than 8 dBm in any 3 kHz band during any time interval of continuous transmission.

According to §15.247(f), the digital modulation operation of the hybrid system, with the frequency hopping turned off, shall comply with the power density requirements of paragraph (d) of this section.

7.6.2. TEST INSTRUMENTS

Name of Equipment	Manufacturer	Model	Serial Number	Last Calibration	Calibration Due
Spectrum Analyzer	R&S	FSU	200409	09/23/2013	09/22/2014

7.6.3. TEST PROCEDURES (please refer to measurement standard)

§15.247(e) specifies a conducted power spectral density (PSD) limit of 8 dBm in any 3 kHz band segment within the fundamental EBW during any time interval of continuous transmission. The same method as used to determine the conducted output power shall be used to determine the power spectral density (i.e., if peak-detected fundamental power was measured then use the peak PSD procedure and if average fundamental power was measured then use the average PSD procedure).

10.2 Method PKPSD (peak PSD)

1. Set analyzer center frequency to DTS channel center frequency.
2. Set the span to 1.5 times the DTS bandwidth.
3. Set the RBW to: $3 \text{ kHz} \leq \text{RBW} \leq 100 \text{ kHz}$.
4. Set the VBW $\geq 3 \times \text{RBW}$.
5. Detector = peak.
6. Sweep time = auto couple.
7. Trace mode = max hold.
8. Allow trace to fully stabilize.
9. Use the peak marker function to determine the maximum amplitude level within the RBW.
10. If measured value exceeds limit, reduce RBW (no less than 3 kHz) and repeat.

7.6.4. TEST SETUP

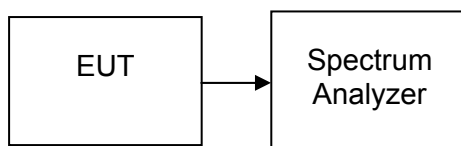



7.6.5. TEST RESULTS

No non-compliance noted

Test Data

Test mode: IEEE 802.11b (Antenna 0)

Channel	Frequency (MHz)	PPSD (dBm)	Limit (dBm)	Test Result
Low	2412	-9.25	8	PASS
Mid	2437	-9.83		PASS
High	2462	-11.35		PASS

Test mode: IEEE 802.11b (Antenna 1)

Channel	Frequency (MHz)	PPSD (dBm)	Limit (dBm)	Test Result
Low	2412	-9.17	8	PASS
Mid	2437	-9.95		PASS
High	2462	-8.99		PASS

Test mode: IEEE 802.11g (Antenna 0)

Channel	Frequency (MHz)	PPSD (dBm)	Limit (dBm)	Test Result
Low	2412	-11.22	8	PASS
Mid	2437	-11.55		PASS
High	2462	-12.12		PASS

Test mode: IEEE 802.11g (Antenna 1)

Channel	Frequency (MHz)	PPSD (dBm)	Limit (dBm)	Test Result
Low	2412	-12.85	8	PASS
Mid	2437	-12.75		PASS
High	2462	-12.96		PASS



Test mode: IEEE 802.11n HT20 MHz (Antenna 0)

Channel	Frequency (MHz)	PPSD (dBm)	Limit (dBm)	Test Result
Low	2412	-16.52	8	PASS
Mid	2437	-13.12		PASS
High	2462	-14.29		PASS

Test mode: IEEE 802.11n HT20 MHz (Antenna 1)

Channel	Frequency (MHz)	PPSD (dBm)	Limit (dBm)	Test Result
Low	2412	-16.62	8	PASS
Mid	2437	-16.70		PASS
High	2462	-16.76		PASS

Test mode: IEEE 802.11n HT40 MHz (Antenna 0)

Channel	Frequency (MHz)	PPSD (dBm)	Limit (dBm)	Test Result
Low	2422	-17.70	8	PASS
Mid	2437	-16.58		PASS
High	2452	-16.82		PASS

Test mode: IEEE 802.11n HT40 MHz (Antenna 1)

Channel	Frequency (MHz)	PPSD (dBm)	Limit (dBm)	Test Result
Low	2422	-18.88	8	PASS
Mid	2437	-18.46		PASS
High	2452	-17.98		PASS



Test Plot

IEEE 802.11b mode (Antenna 0)

PPSD (CH Low)

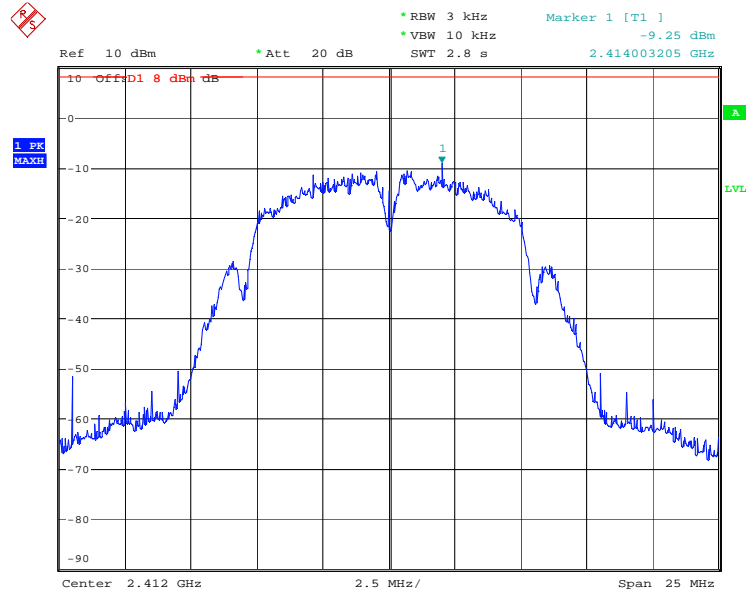

Date: 25.JUL.2014 07:00:54

PPSD (CH Mid)

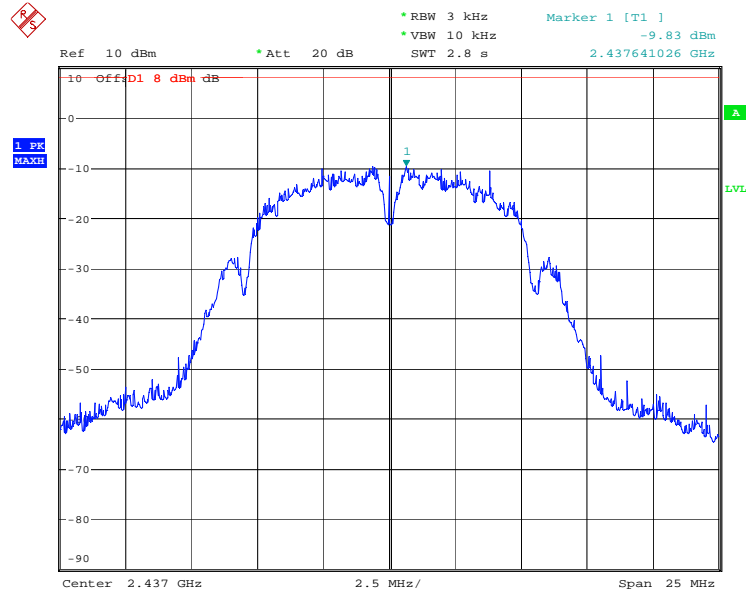

Date: 25.JUL.2014 07:06:00



PPSD (CH High)

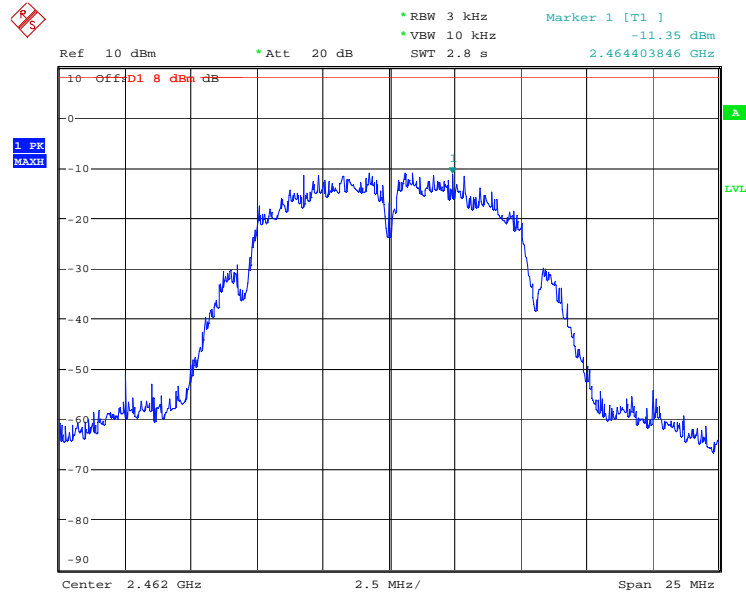

Date: 25.JUL.2014 07:04:01

IEEE 802.11b mode (Antenna 1)

PPSD (CH Low)

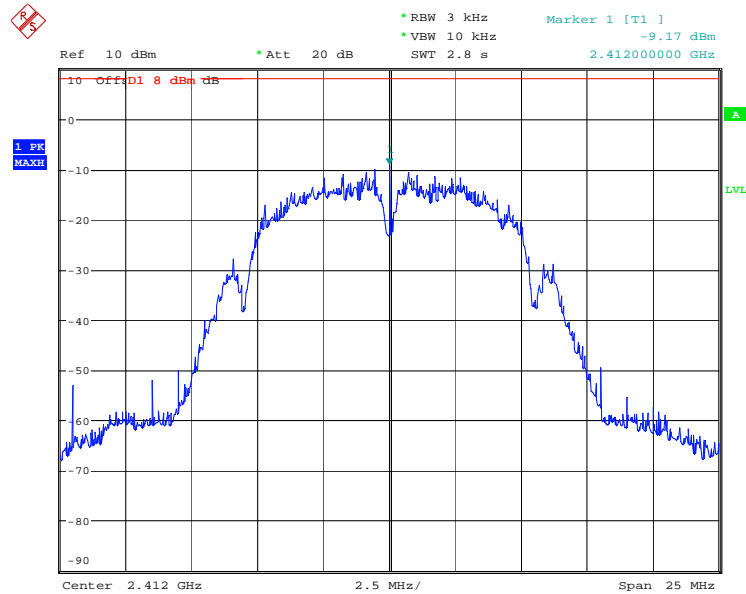

Date: 25.JUL.2014 05:38:10



PPSD (CH Mid)

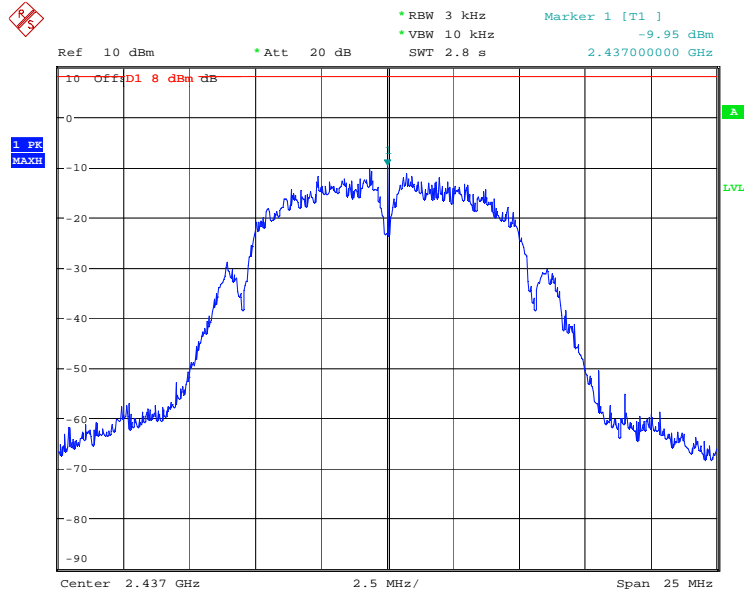

Date: 25.JUL.2014 07:12:53

PPSD (CH High)

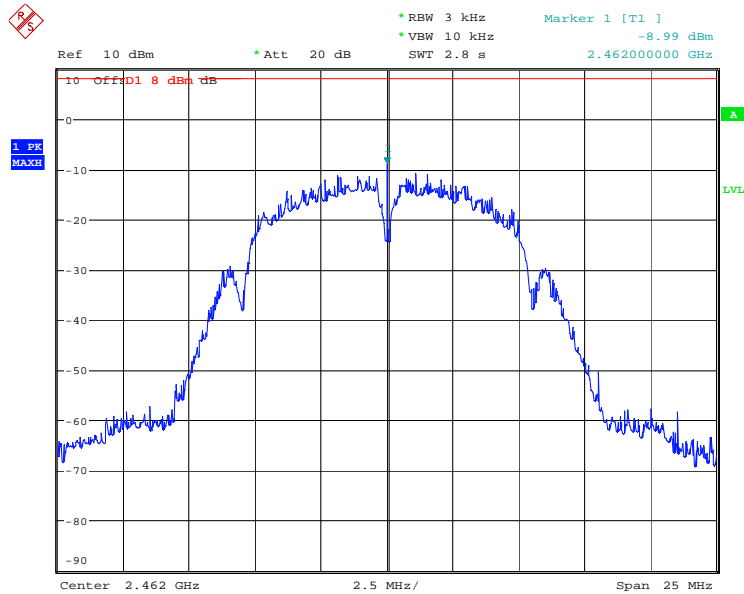

Date: 25.JUL.2014 07:13:41



IEEE 802.11g mode (Antenna 0)

PPSD (CH Low)

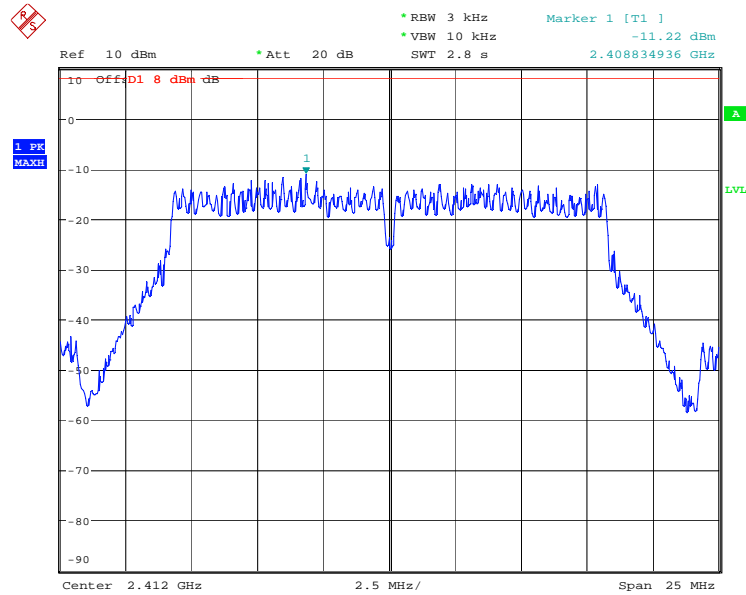

Date: 25.JUL.2014 07:06:52

PPSD (CH Mid)

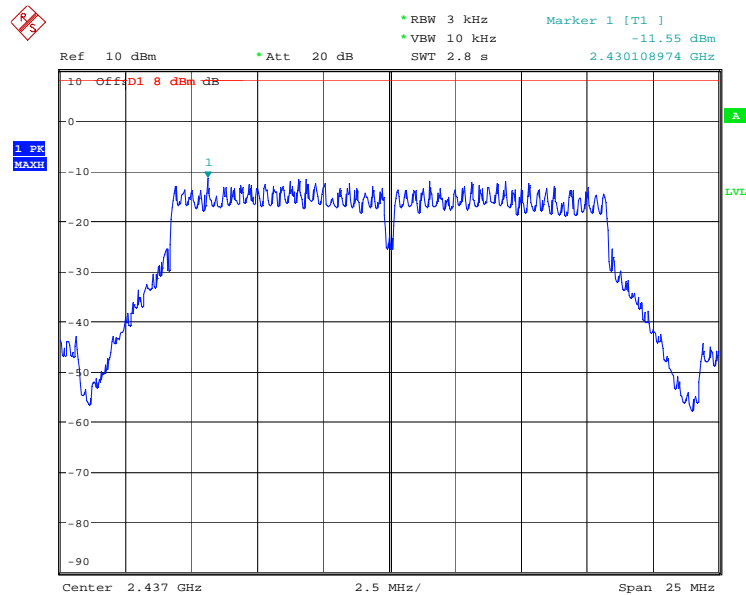

Date: 25.JUL.2014 07:08:02



PPSD (CH High)

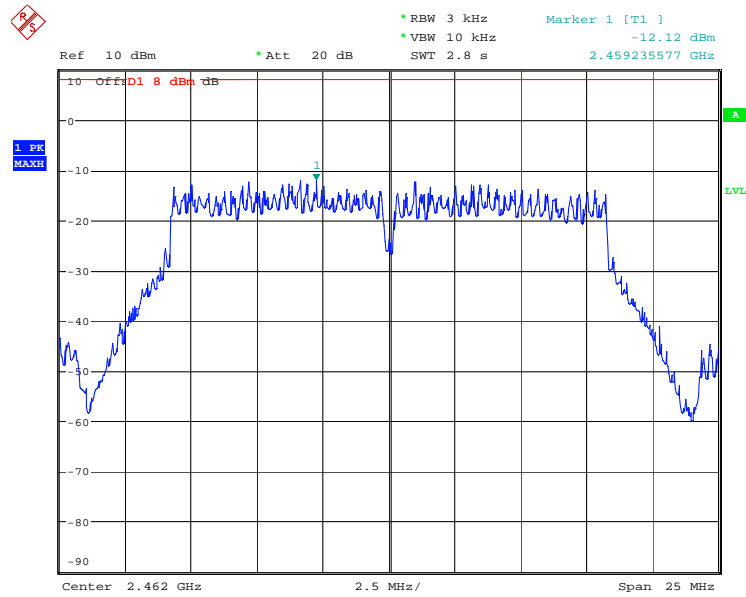

Date: 25.JUL.2014 07:08:37

IEEE 802.11g mode (Antenna 1)

PPSD (CH Low)

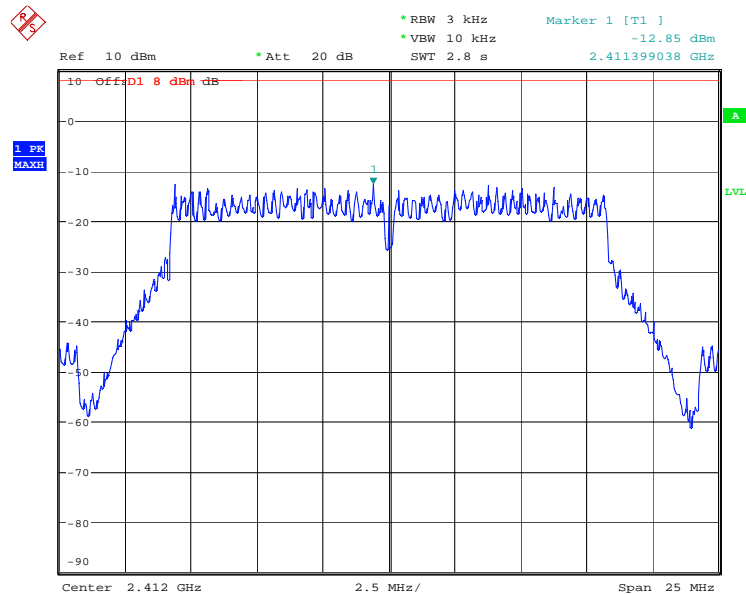

Date: 31.JUL.2014 19:10:56



PPSD (CH Mid)

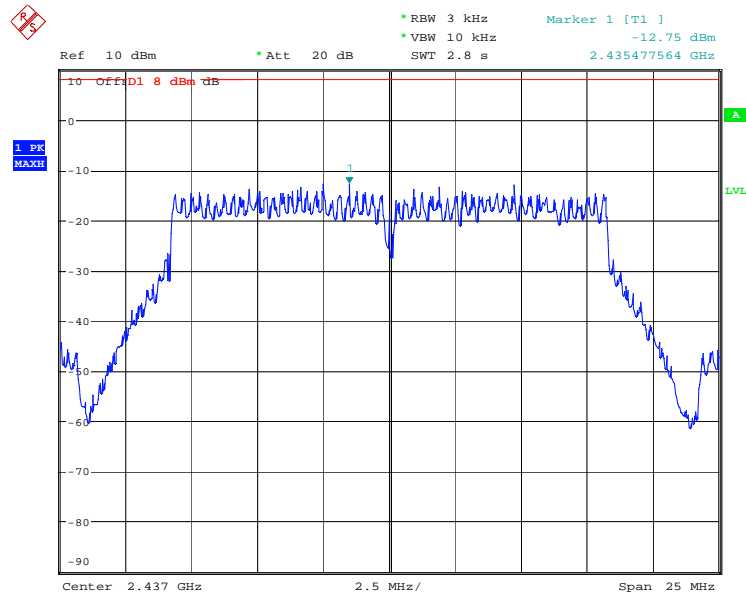

Date: 31.JUL.2014 19:12:16

PPSD (CH High)

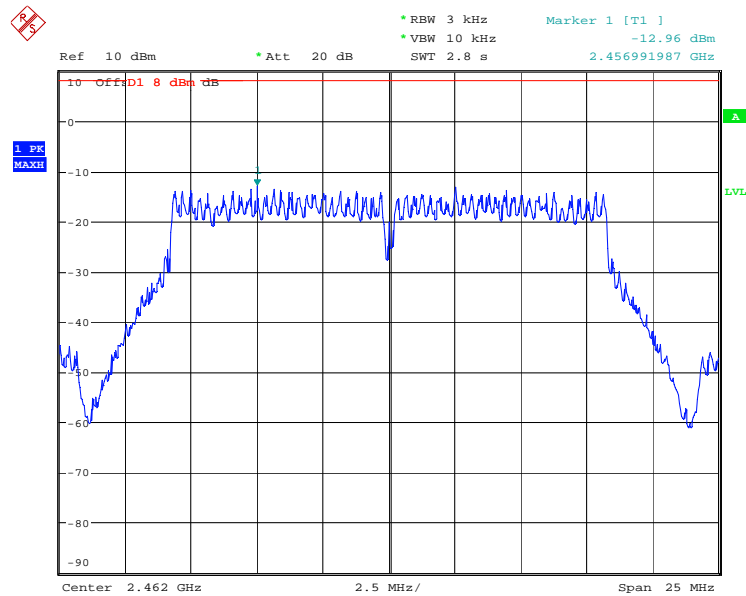

Date: 31.JUL.2014 19:13:03



IEEE 802.11n HT20 MHz mode (Antenna 0)

PPSD (CH Low)

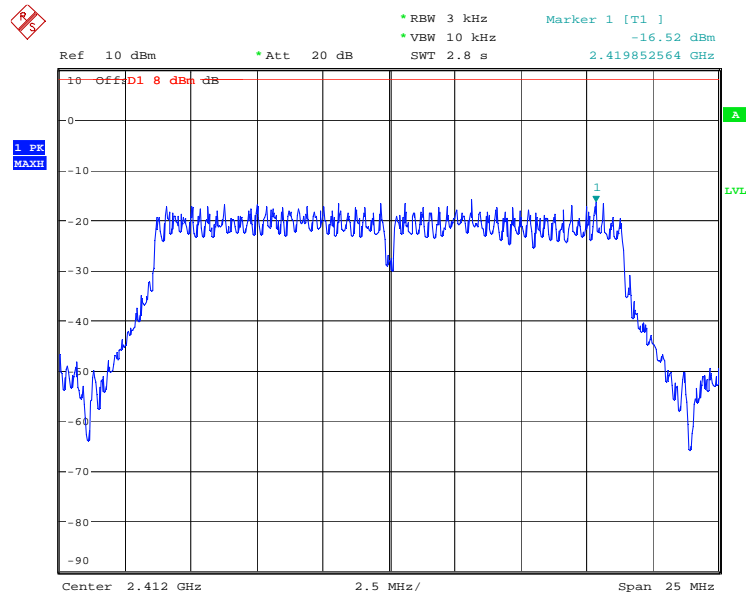

Date: 25.JUL.2014 07:09:15

PPSD (CH Mid)

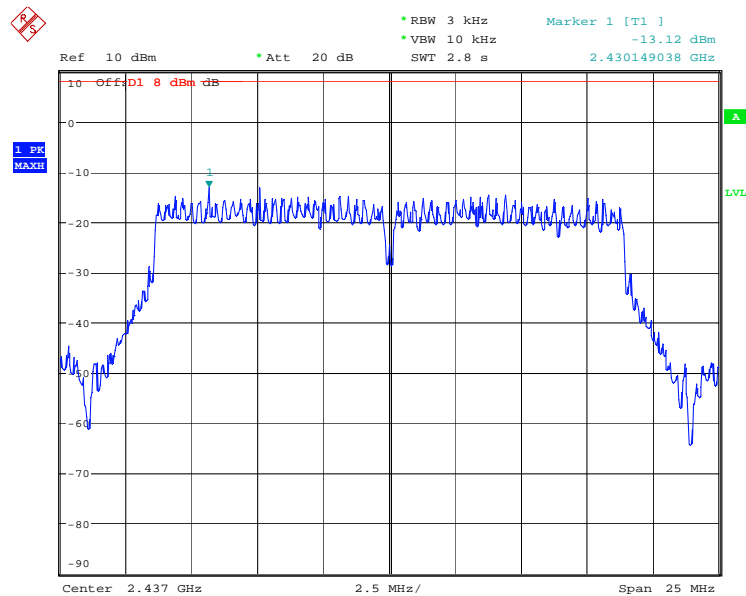

Date: 25.JUL.2014 07:10:06



PPSD (CH High)

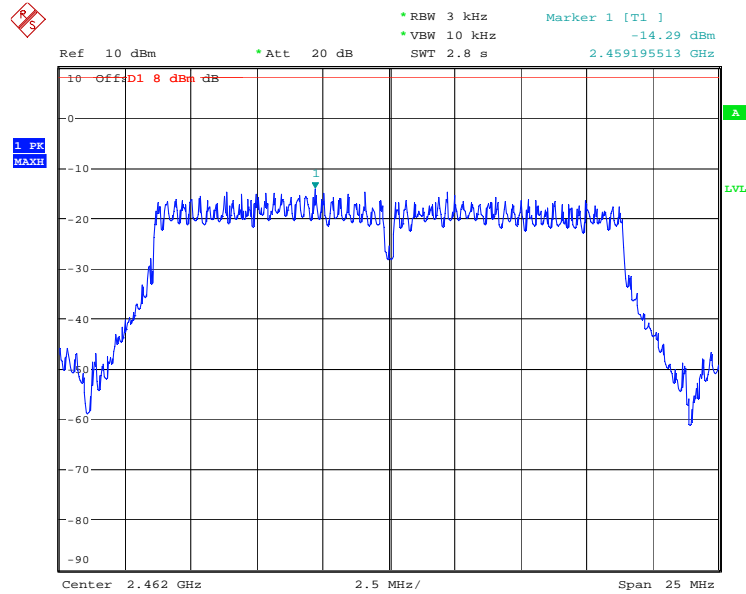

Date: 25.JUL.2014 07:10:44

IEEE 802.11n HT20 MHz mode (Antenna 1)

PPSD (CH Low)

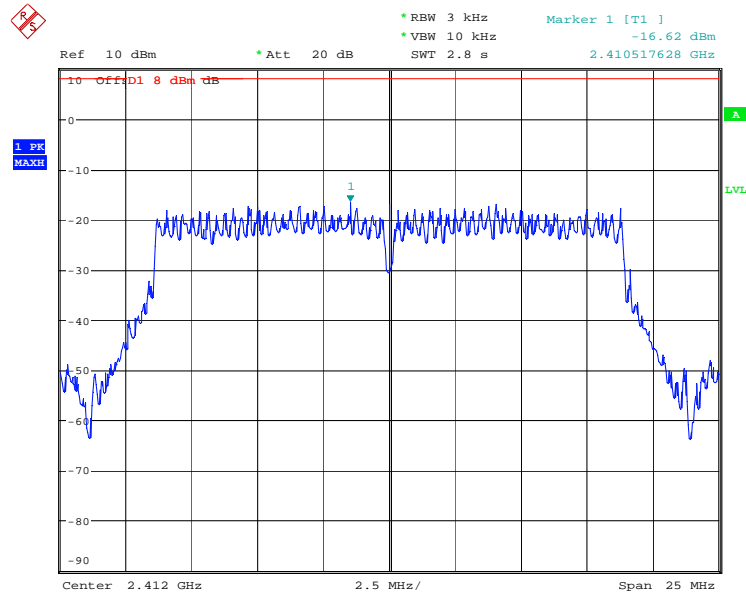

Date: 25.JUL.2014 05:42:33



PPSD (CH Mid)

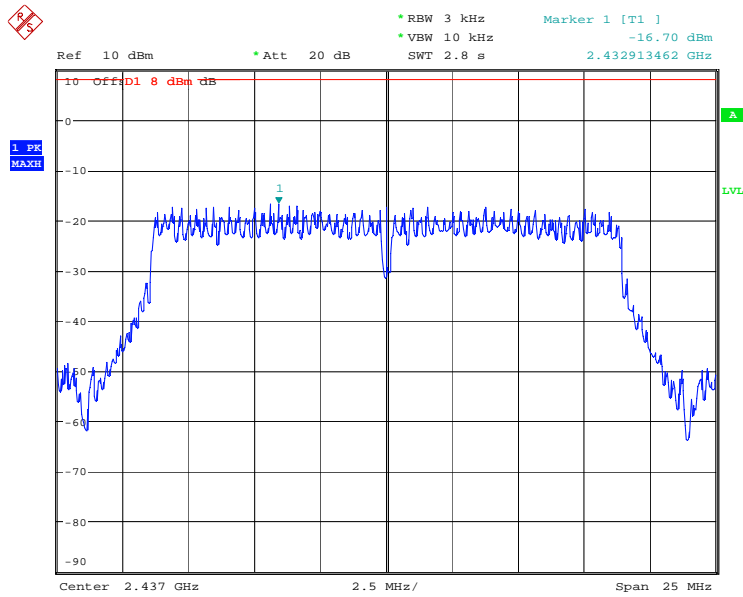

Date: 25.JUL.2014 07:12:02

PPSD (CH High)

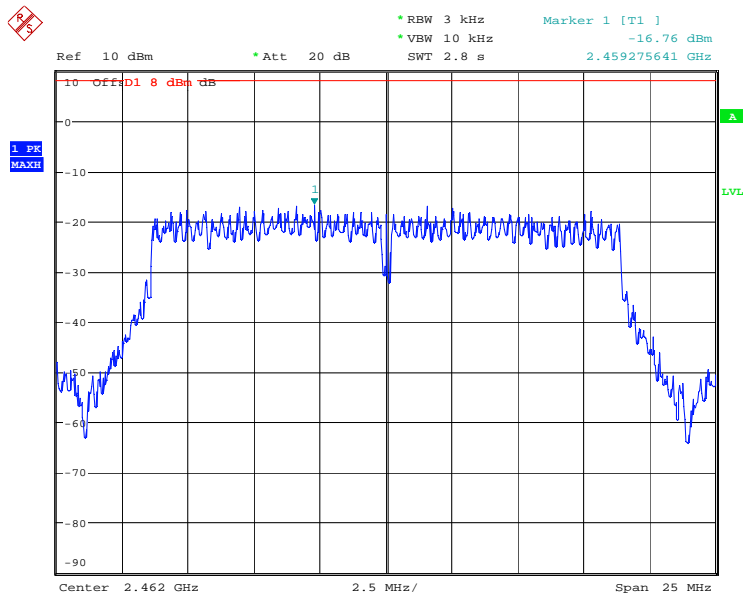

Date: 25.JUL.2014 07:11:20



IEEE 802.11n HT40 MHz mode (Antenna 0)

PPSD (CH Low)

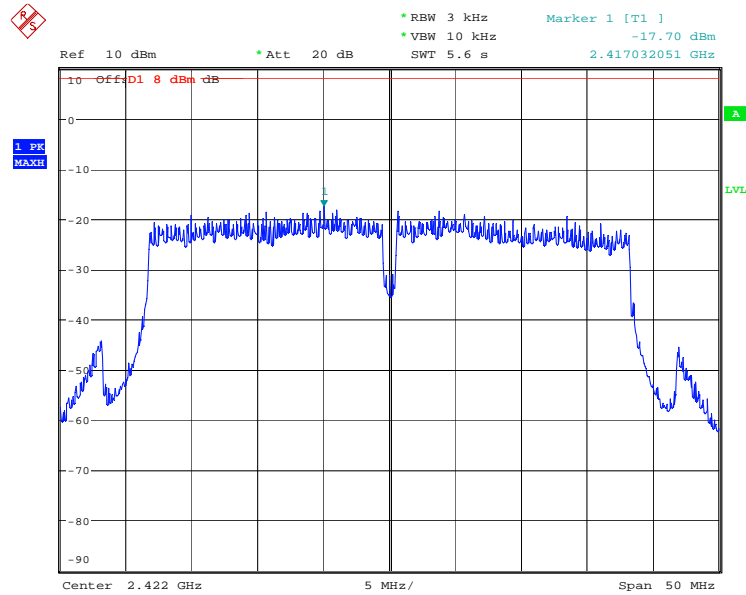

Date: 31.JUL.2014 19:20:44

PPSD (CH Mid)

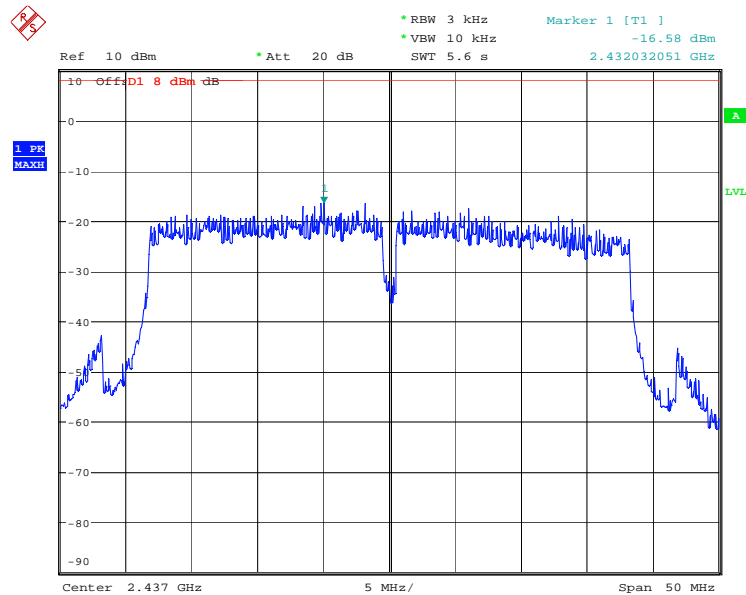

Date: 31.JUL.2014 19:18:49



PPSD (CH High)

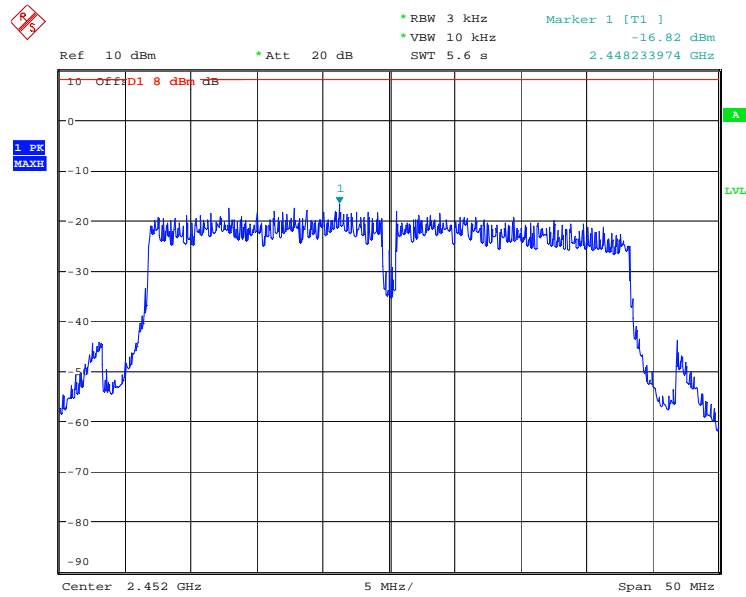

Date: 31.JUL.2014 19:17:02

IEEE 802.11n HT40 MHz mode (Antenna 1)

PPSD (CH Low)

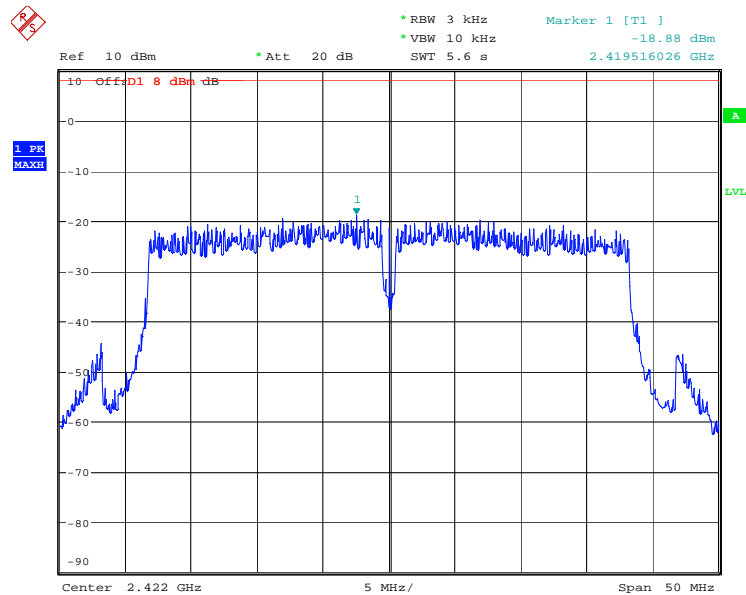

Date: 31.JUL.2014 19:14:16



PPSD (CH Mid)

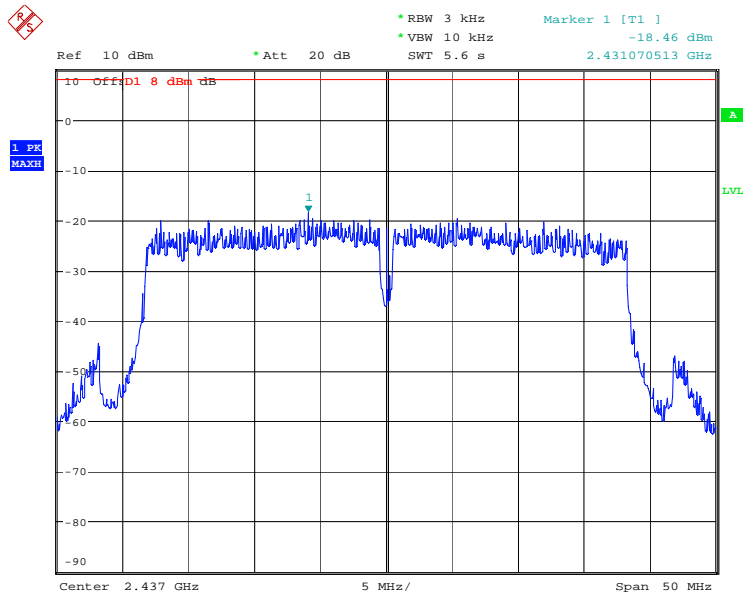

Date: 31.JUL.2014 19:15:07

PPSD (CH High)

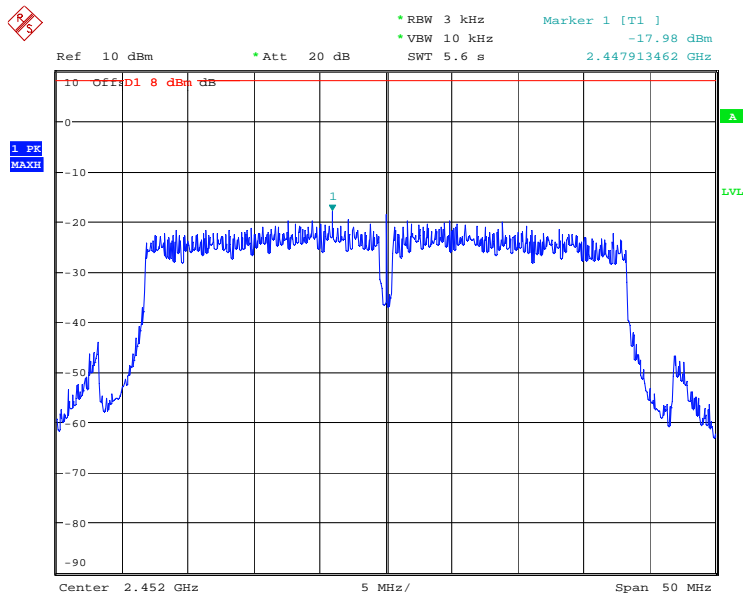

Date: 31.JUL.2014 19:16:10