

Chapter 1

- 1.1 Views of the Device
- 1.2 Get Started
- 1.3 Status Indicators
- 1.4 Enter Information

Chapter 2

- 2.1 Today Screen
- 2.2 Start Menu
- 2.3 Ring tones and Notifications
- 2.4 General Settings
- 2.5 Security

Chapter 3

- 3.1 Make a Call
- 3.2 Receive a Call
- 3.3 Video Telephony
- 3.4 In-Call Options
- 3.5 Special Dialling Requirements
- 3.6 Additional Settings

Chapter 4

- 4.1 Automatic Setup of Your Data Connections
- 4.2 Manual Setup of Your Data Connections
- 4.3 Bluetooth
- 4.4 Beams
- 4.5 Connect to a Wireless LAN

Chapter 5

- 5.1 Text Messaging
- 5.2 MMS
- 5.3 E-mail
- 5.4 Windows Live Messenger

Chapter 6

- 6.1 Introduction to ActiveSync
- 6.2 Install and Configure ActiveSync

Chapter 7

- 7.1 Contacts
- 7.2 Calendar
- 7.3 Tasks
- 7.4 Camera and Video Recorder
- 7.5 Pictures and Videos
- 7.6 Windows Media Player

- 7.7 Internet Explorer Mobile
- 7.8 Java
- 7.9 Wireless Manager
- 7.10 Notes
- 7.11 Office Mobile
- 7.12 Internet Sharing
- 7.13 File Explorer
- 7.14 Windows Live
- 7.15 Remote Desktop Mobile
- 7.16 ClearVue PDF
- 7.17 Voice Speed Dial
- 7.18 FM Radio
- 7.19 Monitor and Projector Connection
- 7.20 Nyditot Virtual display
- 7.21 Add More Programs to your device

Chapter 8

- 8.1 Maintain Your Phone
- 8.2 Reset Your Phone
- 8.3 Manage Your Program Memory

Appendix

- A.1 Battery Information
- A.2 PC Requirement to Run ActiveSync 4.5

A.3 Regulatory Notices
A.4 Specifications

1.1 Views of the Device

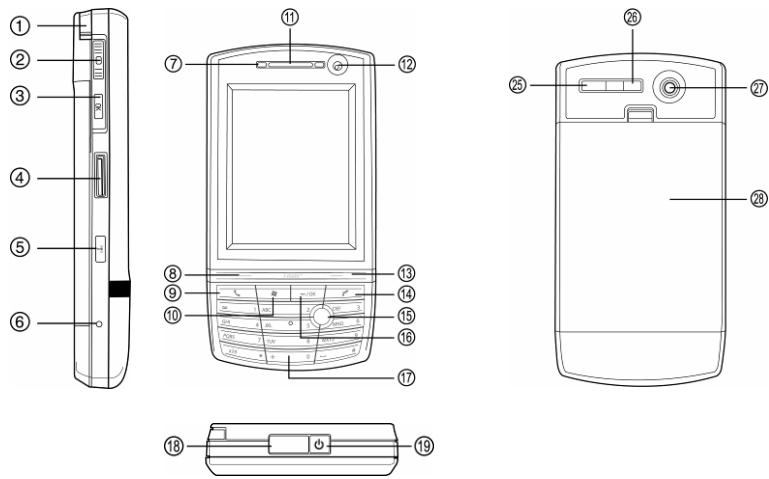

| No. | Item | Function |
|-----|--------------------|--|
| 1 | Stylus | Use the stylus to write, draw or select items on the touch screen. |
| 2 | Jog Wheel | Scroll up or down to move through menus and program instructions. Press for 3 seconds then scroll up or down to adjust the volume. |
| 3 | OK Button | Press to confirm your data entries or to exit the program in use. |
| 4 | Micro SD Card Slot | Insert micro SD memory card with metal contacts facing downwards. |
| 5 | Wi-Fi Button | Press to access the Wireless Manager application. |

| | | |
|----|--|---|
| 6 | Reset | Use the stylus to soft reset the device. |
| 7 | LED | Displays the status of the phone. |
| 8 | Left Soft Key | Open the Calendar from the Today screen and perform the command shown in the label above the button. |
| 9 | Call / Send Key | Press this key to answer an incoming phone call or dial a number. |
| 10 | Windows Start Menu Button | Press to bring up the Start menu. |
| 11 | Earpiece | For use during phone calls. |
| 12 | Video Camera | For making video telephone calls with another party who has a 3G phone with this feature. |
| 13 | Right Soft Key | Open the Contacts list from the Today screen and perform the command shown in the label above the button. |
| 14 | End Key | Press to end a phone call. |
| 15 | Action Button/ Navigation Controller | Action button - confirm the selection from the Navigation controller by pressing the centre button. Navigation controller - press this multi-directional control up, down, left, or right to move through menus or programs. |
| 16 | OK Key | Short Press – Backspace when typing. Long Press – Confirm your data entries or exit the program in use. |
| 17 | Keypad | Use for typing and dialling |
| 18 | Infrared Port | Enable you to exchange files or data with other devices without cables or wires or use the device as a remote control. |
| 19 | Power Button | Press and hold for 2 seconds and then release to put the device in Standby mode. Press and hold for 5 seconds to shut down and turn off the device. |

| | | |
|-----|-----------------------|--|
| 20 | Wi-Fi Plug | External Wi-Fi antenna plug. |
| 21 | Mini-USB Connector | Connect the USB data cable to a PC for synchronization of information, data transmission and battery charging or use the device as an earphone jack or use the hands-free kit. |
| 22 | Multimedia Connector | To send image and sound to a projector or monitor. |
| 23. | Camera & Video Button | Press to launch the camera function and take a picture or record high quality video. |
| 24 | GSM/UMTS Plug | External GSM/UMTS antenna plug. |
| 25 | Video Microphone | Microphone for recording sound whilst recording a video. |
| 26 | Flash | White LED strobe flash. |
| 27 | Camera Lens | The CMOS camera supports a 2 mega-pixel resolution with auto-focus function for high quality colour photos or high quality video recording. |
| 28 | Battery Cover | To remove or replace the battery, push and slide out the battery cover. |

1.2 Get Started

Install the SIM/USIM Card

Follow these steps to install the SIM/USIM card provided by your local network service provider. The SIM/USIM card contains your phone number, service details and phonebook/message memory.

Your device supports both 3V and 1.8V SIM/USIM cards. Some legacy SIM/USIM cards will not function within this device. Consult with your service provider for a replacement SIM card. There might be a fee for this service.

1. Make sure your device is turned off.
2. Pull the battery cover catch up (away from the battery cover) and lift the battery cover up to remove it.
3. Lift the battery to remove it. Then, insert the SIM/USIM card into the SIM card slot with its gold contacts facing down (the cut-off corner of the SIM/USIM card should match the cut-off corner in the slot).
4. Replace the battery and gently push down to fit it into place.
5. Replace the battery cover.

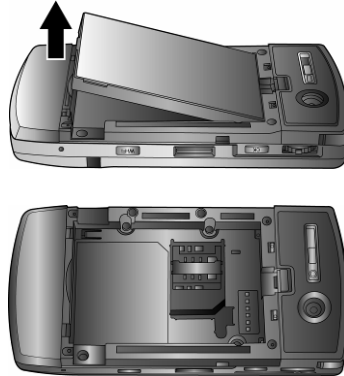

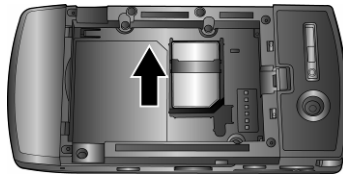



Turn on the device

To turn **ON** the device, press and hold the **Power** button for 4 seconds. When you turn on the device for the first time, you will be asked to complete the screen calibration process. Calibrating the device screen involves tapping the centre of a cross with the stylus as the cross moves around the screen. This process ensures that when you tap the screen with your stylus, the tapped item is activated.

The **Today** screen displays important information, such as upcoming appointments and status indicators. You can tap a section on the screen to open the associated program. If at any point you need to access the **Today** screen, just tap **Start > Today**.





















| No. | Description | No. | Description |
|-----|--|-----|---|
| 1 | Tap to open the Start menu. | 9 | Displays the current owner information. Tap to change the details. |
| 2 | Tap to view the connectivity status. | 10 | Tap to open the related messages, tasks and appointments. |
| 3 | Indicates the radio signal strength. Tap to configure the phone settings . | 11 | Tap to sign into Windows Live.* |
| 4 | Tap to control device/ringer volume level. | 12 | Enter the word to search for and your device will connect to the internet and search using Microsoft Live Search. |
| 5 | Indicates the battery status. Tap to open the Power Settings screen. | 13 | Tap to lock or unlock the device. |
| 6 | Displays the current date and time. Tap to set up date, time, alarm, etc. | 14 | Shows the current function of the left soft key. Tap to open the Calendar screen. |
| 7 | Tap to open the Wireless Manager. If the Wi-Fi  (left) and Bluetooth  (right) icons are displayed, they are available. | 15 | Shows the current function of the right soft key. Tap to open the Contacts screen. |
| 8 | Indicates the status of internet calling. Tap to change the status. | | |















Note: Not supported on all language versions of Windows Mobile Operating System.*

To power **OFF** the device completely, press and hold the **POWER** button for 2 seconds and the system will prompt you to power off the device. In this state, the device cannot receive calls or text messages. To save battery power, your device will automatically go into standby mode if not used for a period of time.

1.3 Status Indicators

Status indicators appear at the top of the screen and on the **Today** screen. The following table lists common status indicators and their meanings.

| Icon | Description | Icon | Description |
|--|--|--|---|
|  | Battery level. |  | Voice call in progress. |
|  | Battery is very low / Charge battery soon. |  | Calls are forwarded. |
|  | Battery charging. |  | Call on hold. |
|  | Battery fault. |  | Missed call. |
|  | Ringer off. |  | GPRS Connection in progress. |
|  | Ringer on. |  | GPRS Connected. |
|  | New instant message. |  | GPRS available. |
|  | Ringer in vibration mode. |  | Indicates if the device is locked / unlocked. |
|  | New e-mail or text message. |  | Connected to the PC. |

| | | | |
|---|--|---|---|
|  | There are more notifications. Tap the icon to view all. |  | Connected to the PC. Synchronization error. |
|  | No SIM card installed. |  | Synchronization in progress |
|  | Roaming. |  | Bluetooth |
|  | No signal |  | Indicates Wi-Fi is turned on. |
|  | Reception is turned off. |  | Wi-Fi network in range |
|  | GSM signal strength. The number of bars indicates the signal strength. |  | Wi-Fi is connected |
|  | 3G in range |  | 3G connected |

1.4 Enter Information





Input Panel

Input Panel provides access to the various available input methods for your device, including **Block Recognizer**, **Keyboard**, **Letter Recognizer** and **Transcriber**. By default, the Input Panel icon appears on the menu bar to indicate which input method is currently selected. The Input Selector arrow (shown at the right side of the Input Panel icon) opens a list of available input methods.



Note: Not supported on all language versions of Windows Mobile Operating System.

The following input methods are available when text entry is possible.

| Icon | Input Method |
|---|--|
|  | Press to switch the keyboard input on or off. |
|  | Input Panel Icon / Press the Input Selector Arrow to change input methods. |
|  | Letter Recognizer or Block Recognizer. |
|  | Transcriber. |

Draw and Write on the Screen

With your device, you can draw directly on the screen or write on the screen and save notes (**Start > Programs > Notes**) in your own handwriting. If you prefer to use handwriting or frequently add drawings to your notes, you may find it helpful to set **Writing** as the default input mode. If you prefer typed text, set **Typing** as the default input mode.

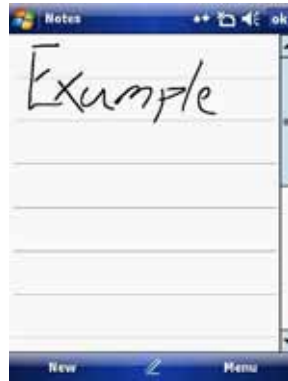



To change the default input mode in **Notes**, tap **Menu > Options** in the notes list and then, in the **Default mode** box, tap either **Writing** or **Typing**, depending on your personal preferences. Tap **OK**.

Voice Recording

You can create a standalone voice recording or you can add a recording to a note.

Create a voice note

1. Tap **Start > Programs > Notes**.
2. If you do not see the **Recording Toolbar**, tap **Menu > View Recording Toolbar**.
3. Tap the record icon  to begin recording.
4. Hold your device's microphone near your mouth or other audio source.
5. Tap the stop icon  when finished recording.

Change recording formats

1. Tap **Start > Settings > Personal tab > Input**.
2. Tap the **Options** tab and in the voice recording format list, tap the format you want.
3. Tap **OK**.

Chapter 2

2.1 Today Screen

2.2 Start Menu

2.3 Ring tones and Notifications

2.4 General Settings

2.5 Security

2.1 Today Screen

The **Today** screen shows your upcoming appointments, active tasks, and information about e-mail messages.

Customise background items on the Today Screen

1. Tap **Start > Settings > Personal tab > Today**.
2. On the **Appearance** tab, select the desired theme for the background of the **Today** screen. You can use one of your own pictures as the background image on the **Today** screen by selecting the **Use this picture as the background** check box and tap **Browse** to view a list of your picture files.
3. On the **Items** tab, select the items you want to appear on the **Today** screen. To change the order of items displayed on the **Today** screen, tap the item and then tap **Move Up** or **Move Down**.
4. Tap **OK**.

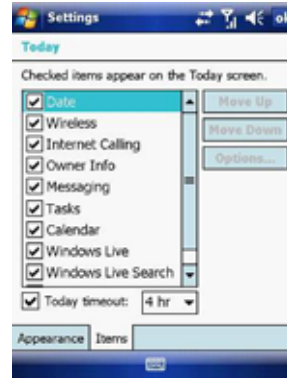

Enter Owner Information

Entering and displaying Owner Information on the **Today** Screen is recommended and allows someone to return the device if lost.

1. Tap **Start > Settings > Personal tab > Owner Information**.
2. In the **Identification** tab, enter your personal information.

If owner information is displayed on the **Today** screen, you can open and edit the information directly from it. Just tap that section of the screen.

2.2 Start Menu

The **Start** menu, located at the top left corner of the **Today** screen, displays a list of programs. It lets you close a screen and switch from one program to another. You can start a program by scrolling through the programs list and then pressing **Enter** or by tapping a program with the stylus.

You can choose which items appear in the **Start** menu:

1. Tap **Start > Settings > Personal tab > Menus**.
2. Select the check boxes of the items you want to appear in the **Start** menu.
You can select up to seven items.

Create folders and shortcuts

You can also create folders and shortcuts that appear on the **Start** menu. Open **ActiveSync** on your PC, click **Explore**. In the Mobile Device window, double click **Mobile Device > Windows > Start Menu**, then create the folders and shortcuts that you want. You will see the added items after you synchronize.

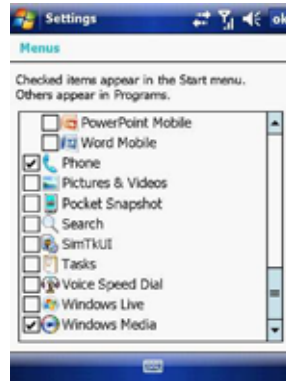

2.3 Ring tones and Notifications

Change ring tones

1. From the **Phone** screen, tap **Menu > Options > Phone** tab.
2. In the **Ring tone** list, tap the sound you want to use.

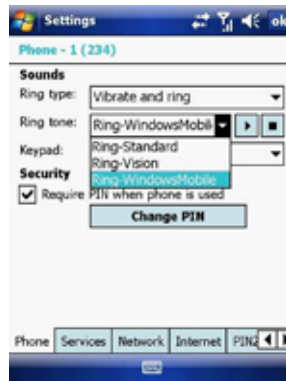

Note: To use custom *.wav, *.mid, *.mp3, or *.wma files as ring tones, use ActiveSync on your PC to copy the file to the **Windows/Rings** folder on your device. Then, select the sound from the ring tone list. For more information about copying files to your device, see ActiveSync Help on your PC.

Assign ring tones to Contacts

It is also possible to assign a specific ring tone to a Contact:

1. Go to **Start > Contacts** and tap on the desired Contact.
2. Select **Menu > Edit**.
3. In the **Ring tone** field, select your desired ring tone.

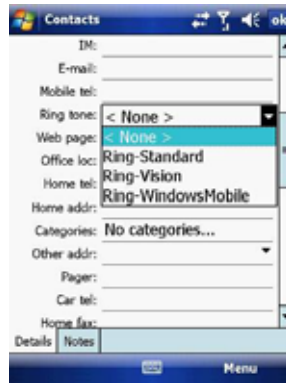

Change the ring type

You can change the way that you are notified of incoming calls. For example, you can choose to be notified by a ring, vibration or a combination of both.

1. From the Phone keypad, tap **Menu > Options > Phone** tab.
2. In the **Ring type** list, tap the desired option.

Set an alarm

1. Tap **Start > Settings > System** tab > **Clock & Alarms > Alarms** tab.
2. Tap **<Description>** and enter a name for the alarm.
3. Tap the day of the week for the alarm. You can select multiple days by tapping each desired day.
4. Tap the time to open a clock and set the time for the alarm.
5. Tap the alarm icon  to specify the type of alarm you want. You can choose a flashing light, a single sound, a repeating sound or vibration.
6. If you choose to play a sound, tap the list next to the **Play sound** check box and tap the sound you want.

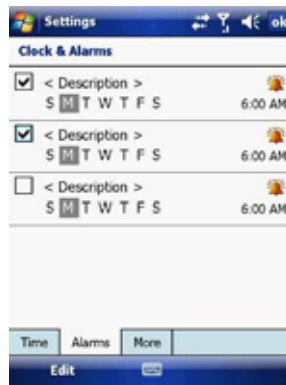

Choose how to be notified about events or actions

1. Tap **Start** > **Settings** > **Personal** tab > **Sounds & Notifications**.
2. On the **Sounds** tab, choose how you want to be notified by selecting the appropriate check boxes.
3. On the **Notifications** tab, tap an event name and choose how you want to be notified by selecting the appropriate check boxes. You can choose from several options, such as a special sound, a message, or a flashing light.

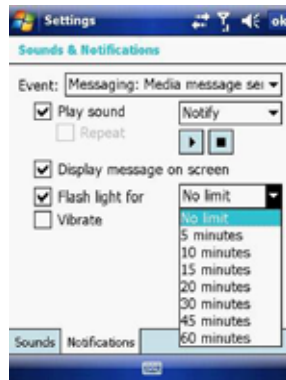

2.4 General Settings

Set the time and date:

1. Tap **Start > Settings > System tab > Clock & Alarms.**
2. Select the correct time zone and change the date or time.

Set the time and date for a different location

If you visit or communicate with someone in a particular time zone often, you can select it as your visiting time zone.

1. Tap **Start > Settings > System tab > Clock & Alarms.**
2. Tap **Visiting.**
3. Select the correct time zone and change the time or date.

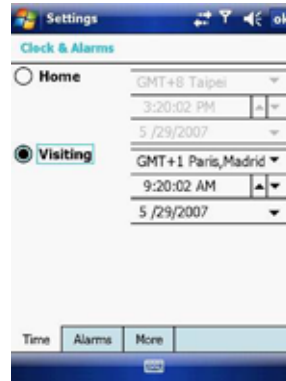

Change language and regional settings

The style in which numbers, currency, dates, and times are displayed is specified in regional settings.

1. Tap **Start > Settings > System tab > Regional Settings**.
2. On the **Region** tab, select your region and language.
3. The region you select determines which options will be available on the other tabs.
4. To customise settings further, tap the appropriate tabs and select desired options.

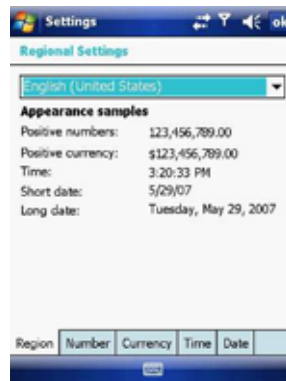

Reassign programs or shortcuts to program buttons

1. Tap **Start > Settings > Personal tab > Buttons**.
2. A list of buttons and their current assignments is displayed on the **Program Buttons** tab.
3. Tap the button you want to reassign. To help you identify the buttons, there are numbers and icons representing their original functions.
4. In the **Assign a program** box, tap the program or shortcut to assign.
5. Tap **OK**.

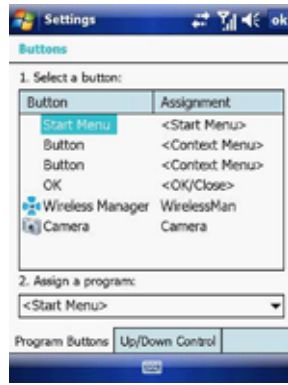

Increase or decrease screen text size

1. Tap **Start > Settings > System tab > Screen > Text Size** tab.
2. Move the slider to increase or decrease the text size.

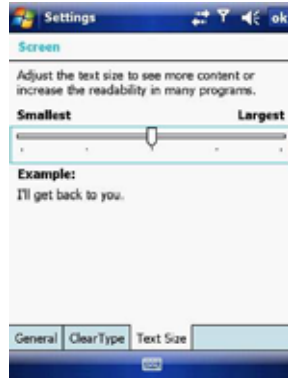

Adjust the speed for scrolling

1. Tap **Start** > **Settings** > **Personal** tab > **Buttons** > **Up/Down Control** tab.
2. Do one of the following:
 - Under **Delay before first repeat**, move the slider to shorten or lengthen the time that elapses before scrolling begins.
 - To change the time it takes to scroll from one item to the next, under **Repeat rate**, move the slider to adjust the speed.

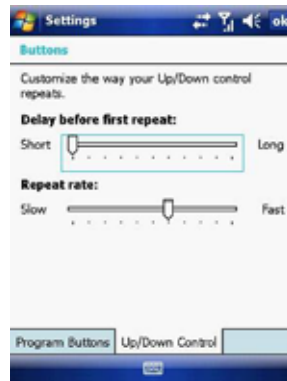

Change the device name

1. Tap **Start** > **Settings** > **System** tab > **About**.
2. Tap the **Device ID** tab.
3. Enter a name.

The device name is used to identify the device in the following situations:

- Synchronizing with a PC.
- Connecting to a network.
- Restoring information from a backup.



Note: The device name must begin with a letter, consisting of letters from A to Z, numbers from 0 to 9, and cannot contain spaces. Use the underscore character to separate words. If you synchronize multiple devices with the same PC, each device must have a unique name.

Make the battery last longer

1. Tap **Start > Settings > System tab > Power**. On the **Advanced** tab, you can specify when your device turns off, to conserve battery power. For optimum conservation, specify 3 minutes or less.
2. Use the AC adapter to plug your device into external power whenever possible, especially when using a microSD card, a modem or other peripheral.
3. Adjust the backlight settings.

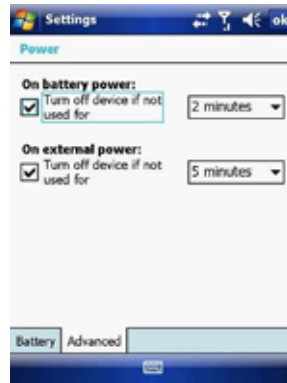

Adjust backlight brightness

1. Tap **Start > Settings > System tab > Backlight > Brightness** tab.
2. Move the sliders right to increase the brightness or left to decrease it.

Set the backlight to dim after a time delay

1. Tap **Start > Settings > System tab > Backlight**.
2. Tap the **Battery power** tab or the **External power** tab.
3. Select the **Turn off backlight if device is not used for** check box and specify the time delay.



Close a program

In most cases, programs automatically close to free needed memory. However, you can close programs manually.

1. Tap **Start > Settings > System > Memory** tab > **Running Programs**.
2. In the **Running Programs** list, tap the program you want to close and tap **Stop**.



Change the orientation of the screen

You can use your Pocket PC in landscape or portrait modes, depending on how you wish to use the device.

1. Tap **Start > Settings > System tab > Screen > General tab**.
2. Choose whether you wish to use the device in **Portrait** or **Landscape** modes. **Landscape** can be right or left-handed. Tap **OK** to make the changes.



2.5 Security

SIM Security

To protect your phone with a PIN:

1. From the Phone screen, tap **Menu > Options > Phone** tab.
2. Tap **Require PIN** when the phone is used.
3. To change the PIN at any time, tap **Change PIN**.

Note: Emergency calls can be placed at any time, without a PIN.

Protect your device with a password

You can help keep your data more secure by requiring a password every time the device is turned on.

1. Tap **Start > Settings > Personal** tab > **Lock**.
2. Select the **Prompt if device unused for** check box. In the box to the right, select how long your device must be turned off before a password is needed. In the **Password type** box, select the type of password you want to use. Enter the password and, if necessary, confirm it. If the device is configured for network connection, use a strong password for better network security.
3. On the **Hint** tab, enter a phrase that will help you remember your password but does not allow others to guess it. The hint will be displayed after the wrong password is entered four times.
4. Tap **OK**. The next time the device is turned on you will be prompted to enter your password.

Note: Each time a wrong password is entered, the time the device takes to respond will get longer and longer until the device appears to be not responding. If you forget your password, you must follow the instructions in your owner's manual to clear memory before you can access your device.

Change your password

1. Tap **Start > Settings > Personal** tab > **Lock**. You will be prompted to enter your current password.
2. In the **Password** box, enter your new password.
3. On the **Hint** tab, enter a phrase that will help you remember your new password but does not allow others to guess your password. The hint will be displayed after the wrong password is entered four times.
4. Tap **OK**.

Encrypt your files

1. Tap **Start > Settings > System tab > Encryption**.
2. Select **Encrypt files placed on storage cards** to encrypt files as they are placed on a storage card.

Chapter 3

3.1 Make a Call

3.2 Receive a Call

3.3 Video Telephony

3.4 In-Call Options

3.5 Special Dialling Requirements

3.6 Additional Settings

3.1 Make a Call

Like a standard mobile phone, you can use your i-mate™ Windows Mobile® Pocket PC Phone to make, receive and keep track of calls. You can also take notes while talking, dial directly from **Contacts** and easily copy SIM/USIM contacts to **Contacts** on the device.

In order to make calls, you will need to insert your SIM/USIM card into the device as described in *Chapter 1*. Most SIM/USIM cards are preset with a PIN (personal identification number), provided by your wireless service provider. If this option is enabled in your SIM/USIM card, you will be prompted to enter the PIN when the unit is switched on.

Note: If your PIN is entered incorrectly three times, the SIM/USIM card will be blocked. If this happens, you can unblock it with the PUK (PIN Unblocking Key) obtained from your wireless service provider.

You can make a call from **Phone**, **Contacts**, **Speed Dial**, **Call History** and **SIM/USIM Manager**.

Make a call from the Phone screen

On the **Phone** screen:

1. Tap the desired phone number and then tap the **SEND** button.
2. To open the Phone screen, either use the stylus to tap **Start > Phone** or press the **SEND** button.



Make a call from the Contacts screen

1. Tap **Start > Contacts**.
2. To search for a contact, enter the desired name and number in the search field, or tap the letter corresponding to the name in the alphabet bar.
3. Tap the desired contact and tap **Call** or press the **SEND** button.

You can also tap the desired contact in the **Contacts** list and tap the phone number that you want to call. Or, tap and hold the desired contact. On the shortcut menu, tap **Call Work**, **Call Home**, or **Call Mobile**.

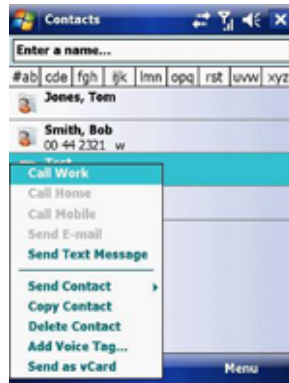

By default, the mobile telephone number (m) of a contact is dialed when you make a call from **Contacts**. However, you can specify that a different phone number is used instead.

1. Tap **Start > Contacts**.
2. Press the **Navigation Controller** up or down to select the contact.
3. Press the **Navigation Controller** left or right. The letters representing the number will change as you scroll through them.

Make a call from Call History

1. On the **Phone** screen, tap **Call History**.
2. Tap **Menu > Filter** and tap a category.
3. Scroll to the desired contact or phone number and tap **Call** or press the **SEND** button.

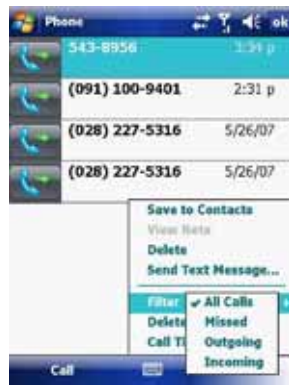

Make a call from Speed Dial

Use **Speed Dial** to call frequently-used numbers with a single tap. For example, if you assign a contact to **Location 2** in **Speed Dial**, you can tap and hold it on the **Phone** screen to dial the contact's number. Before you can create a **Speed Dial** entry, the number must be in **Contacts**. To create a **Speed Dial** entry:

1. On the **Phone** screen, tap **Speed Dial**.
2. Tap **Menu > New**.
3. Tap a contact. Tap the phone number for which you want to create a **Speed Dial** entry.
4. In the **Location** box, select an available location for the new **Speed Dial** entry.



Note: To create a **Speed Dial** entry from **Contacts**, tap and hold the contact name, tap **Menu** > **Add to Speed Dial** and select an available location for the new **Speed Dial** entry. To delete a **Speed Dial** entry, in the **Speed Dial** list, tap and hold the desired entry and tap **Delete**.

Make an emergency call

To make an emergency call, just enter the emergency phone number for your location and press **SEND**.

Note: You can make calls to emergency services under any circumstances, even if you have enabled the SIM PIN or locked the device. The ability to make emergency calls depends on network availability.

3.2 Receive a Call

When you receive a phone call, a message will appear, giving you the option to either answer or ignore the incoming call.

1. To answer the call, tap **Answer** or press the **SEND** button.
2. To reject the call, tap **Ignore** or press the **END** button.



End a call

Once an incoming or outgoing call is in progress, you can tap **End** or press **END** on the device to hang up.

3.3 Video Telephony

Tapping the **Video Call** button allows you to make a VT (video telephone) call.



| No | Item | Description |
|----|----------------------------|---|
| 1 | Caller Image | Displays the caller image. |
| 2 | Brightness | Use + and - to increase or decrease the screen brightness. |
| 3 | Camera | Turn on or off the caller image. |
| 4 | Keypad | Tap to return to the keypad. |
| 5 | Internal / External Camera | Switches between the camera facing you and the camera pointing away from you. |
| 6 | View Mode | There are 4 view modes available, tap this button to switch between them:  Only Receiver - Displays only the person you are calling.  Only Sender - Displays your image only.  Standard Mode - Displays both the caller and the receiver (the sender is smaller). |

| | | |
|----|----------------|---|
| | |  Sender is large - The sender image is large and the receiver image is small. |
| 7 | Speaker | Turn the speaker on/off. |
| 8 | Menu | <p>Contains:</p> <p>Hold - Place the current call on hold</p> <p>Mute - Mute the speaker</p> <p>Turn Speakerphone On – Turn the speaker phone on or off.</p> <p>Turn Handsfree On - Turn handsfree on or off.</p> <p>Conference – Begin a call with more than one person.</p> <p>Paste</p> <p>Save to contacts – Save the current caller to the contacts.</p> <p>Create note - Add a note to the call.</p> <p>Call history -Display the call history.</p> <p>Speed dial – Tap to see speed dial numbers. See <i>Chapter 3.5 for details</i>.</p> <p>Options</p> <p>Video call options – Contain 3 tabs: General, Services and About.</p> <ul style="list-style-type: none"> - General – Select the default video image setting, File when selecting a user defined video image and video call ringtone. - Services – Select the available services and tap Getting settings to change the settings. - About – Displays information about the application. |
| 9 | End | End the call. |
| 10 | Receiver Image | See the person who receives your call. |

3.4 In-Call Options

Put a call on hold

If this option is enabled, your device notifies you when you have another incoming call and gives you the choice of rejecting or accepting the call.

If you are already on a call and accept the new call, you can choose to switch between the two callers or set up a conference call between all three parties.

- Tap **Answer** to take the second call, which will put the first call on hold.
- To end the second call and return to the first call, tap **End** or press the **END** button on your device.

To switch between calls, tap **Swap** or press the **SEND** button.

Set up a conference call

1. Either put a call on hold and dial a second number or accept a second incoming call when you already have one in progress.
2. Tap **Conference**.

Note: Not all service providers support conference calling. Contact your service provider for details.

Turn on and off the speakerphone

The built-in speakerphone on your device allows handsfree operation or lets other people listen to the conversation. To activate the speakerphone mode, press and hold the **SEND** button or tap **Speaker On** on the screen. The

speakerphone icon  will appear in the title bar. To turn off the speakerphone, tap **Speaker Off**.

Mute a call

You can turn off the microphone during a call so that you can hear the caller but the caller cannot hear you. During a call, tap **Mute**.

- When the microphone is turned off, the mute icon will appear on the screen.
- Tap **Unmute** to turn on the microphone again.

3.5 Special Dialling Requirements

Insert a pause in a dialling sequence

Calls to certain networks may require a pause in between the dialled digits:

1. Tap **Start > Contacts**.
2. Click the contact whose phone you want to insert a pause.
3. Select the phone number and add a 'p' character where you want to insert a 3 second pause.
4. Select the phone number and add a 'w' character where you want to insert a manual pause.
5. To resume dialling after reaching a manual pause, press **SEND**.

Insert an International Country Code

To make an international call, you must insert a country code at the beginning of the dialling sequence for the phone number. Tap and Hold '0' on the **Phone** screen until a (+) sign appears and then insert the rest of the number.

3.6 Additional Settings

Phone services

Phone Services, such as **Call Waiting**, enable you to choose how to handle all incoming calls on your device.

Choose services

1. Tap **Start > Settings > Personal tab > Phone > Services tab**.
2. Tap the service you want to use and tap **Get Settings**.



Networks

You can view available wireless networks, determine the order in which your device accesses another network if the current one is unavailable, and specify whether you want to change networks manually or automatically.

Change phone network settings

1. Tap **Start > Settings > Phone > Network tab**.
2. By default, your device displays the current network as offered by your service provider. You can customise this to your preferred network.

Set preferred networks

1. Tap **Start > Settings > Phone > Network** tab. By default, network selection field is set to **Automatic**. However, you can set it to **Manual** to choose your own network at any point of time.
2. Tap **Set Networks**.
3. Select the networks in **Preferred networks** and sort them according to your preference.
4. Tap **OK**.

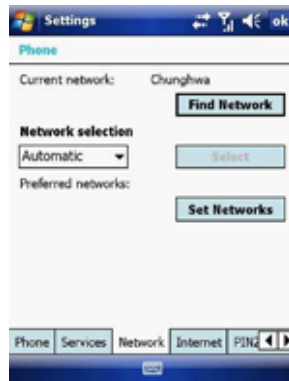

Change the keypad tone

You can change the tone you hear when entering a phone number on the keypad. If set to **Long tones**, the tone is heard continuously for as long as the number on the keypad is tapped. Use this setting if you are having trouble accomplishing tasks that rely on tones from your phone such as accessing messages from an answering machine. If set to **Short tones**, the tone is heard only for one or two seconds. If set to **Off**, no tone will be heard.

1. From the **Phone** screen, tap **Menu > Options > Phone** tab.
2. In the Keypad list, tap the option you want.

Automatic answering

You can set the phone to automatically answer calls when using the headset. To do this:

1. From the **Today** screen, tap **Start > Settings > Personal tab > Phone > Auto-answer** tab.
2. Tap the **When using headset, auto answer after** check box.
3. Select the number of seconds from the drop down menu.

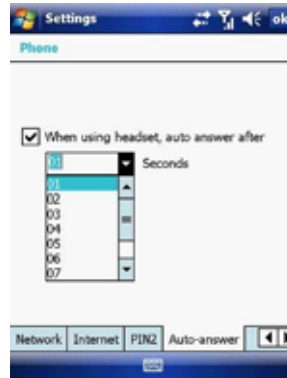

Chapter 4

4.1 Automatic Setup of Your Data Connections

4.2 Manual Setup of Your Data Connections

4.3 Bluetooth

4.4 Beams

4.5 Connect to a Wireless LAN

4.1 Automatic Setup of Your Data Connections

Your device is equipped with powerful networking functions that enable you to connect to the Internet through a General Packet Radio Service (GPRS) network.

GPRS is a service that allows information to be sent and received across a mobile telephone network.

Your device is able to configure itself for data services from many of the major GSM/GPRS operators across the world. Simply insert your SIM/USIM card and switch on your device. When the device powers on it will prompt for the configuration steps and configure itself for Web, MMS, and WAP services. If the settings are not known for your operator, the device will notify you and you will need to enter them manually.

Note: The use of Web, WAP and Multimedia Messaging Services is subject to your Mobile Service Provider. You must ensure that your subscription has Web, WAP and MMS before using those services.

4.2 Manual Setup of Your Data Connections

You can set up connections to the Internet or to a corporate network and exchange e-mail or instant messages.

Your device has two connection setting categories: **My ISP** (Internet Service Provider) and **My Work Network**. The **My ISP** settings are used to connect to the Internet, and the **My Work Network** settings can be used to connect to any private corporate network.

To ensure that both **My ISP** and **My Work Network** connections are displayed:

- Tap **Start > Settings > Connections** tab > **Connections > Advanced** tab > tap the **Select Networks** button.
- From **Programs that automatically connect to the Internet**, select **My ISP**.
- From **Programs that automatically connect to a private network**, select **My Work Network**.

Connect to the Internet via ISP

Obtain the following information from your ISP:

- Access point name or server phone number.
- User name (if required).
- Password (if required).
- Domain (if provided by an ISP or a network administrator).
- Proxy settings (if required).

1. Tap **Start > Settings > Connections** tab > **Connections**.
2. Tap **Add a new modem connection**.
3. Enter a name for the connection.
4. Select a modem from the list. For example, if you want to use the mobile phone network, select **Cellular Line** or **Cellular Line (GPRS)**.
5. Tap **Next**.
6. Complete the Connection Wizard by entering the required information and tapping **Finish**.



Connect to a private network

Obtain the following information from your ISP:

- Access Point name or server phone number.
- User name (if required).
- Password (if required).
- Domain (If provided by an ISP or a network administrator).
- Proxy settings (if required).

1. Tap **Start > Settings > Connections** tab > **Connections**.
2. In **My Work Network**, follow the instructions for each type of connection.
3. Once finished, tap **Edit my proxy server** and enter the Proxy Information, including any WAP Proxy required by the operator if you are setting up a connection to their WAP site.
4. Complete the Connection Wizard and tap **Finish**.

Connect to a VPN using the Internet

Please ensure that you have setup a successful GPRS / Wi-Fi connection. The VPN connection uses existing Internet connections to connect to your work network. Refer to the next section, *Connect to an Intranet URL*, for more information.

1. If the Work Connection is not being used for any other connection, tap on **Add a new VPN server connection** and skip to step 4.
2. Tap **Start > Settings > Connections > Connections > Advanced tab > tap Select Networks.**
3. Create a new connection to a private network by tapping **New...** under the **Programs that automatically connect to a private network** list. This new network connection must be selected from this menu when necessary to connect to a VPN. Assign a name for your choice and tap the **VPN tab > New.**
4. Complete the VPN setup wizard using the settings provided by your network administrator, which should include Host Name/IP, VPN Type, User Name, Password and Domain.



5. If you selected **IPSec VPN type**, tap **Next** to select the type of authentication required. If **Pre-Shared** key is selected, enter the key.
6. Check the advanced settings and complete the settings according to the instructions from your network administrator.

Connect to an Intranet URL

A work URL exception tells Internet Explorer Mobile and/or ActiveSync to look on the work network to find that URL instead of searching the Internet. This also has to be setup if you wish to browse intranet websites through your VPN connection:

1. On the **Today** screen, tap **Start > Settings > Connections > Advanced > Exceptions**.
2. In **Work URL Exceptions**, tap **Add new URL** and enter the URL. Tap **OK**.

Note: Separate multiple URLs with a semicolon.

You should not create URL exceptions for URLs on the Internet. An Intranet URL can be either an IP address or FQDN (Fully Qualified Domain Name).

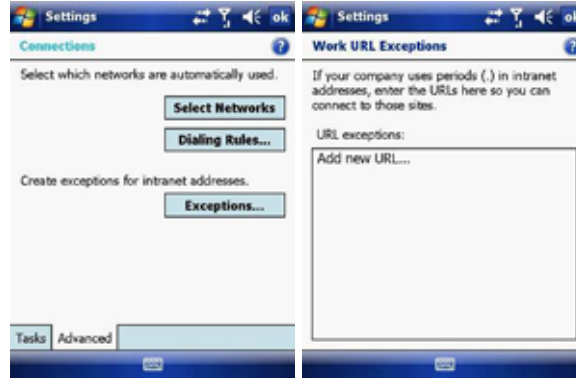

4.3 Bluetooth

Bluetooth is a short-range wireless communications technology. Devices with Bluetooth capabilities can exchange information over a distance of about 10 meters without a physical connection. You can even beam information to a device in a different room as long as it is within the Bluetooth signal coverage range.

The software included with your device allows you to use Bluetooth in the following ways:

1. Beam information such as files, appointments, tasks and contact cards between devices that have Bluetooth capabilities.
2. Use a Bluetooth headset.

Turn Bluetooth on or off

1. On your device, tap **Start > Settings > Connections tab > Wireless Manager**.
2. Select **Turn on Bluetooth**.
3. Tap Bluetooth **Settings > Mode** tab. Check the **Make this device visible to other devices** box if you want your device to be visible to other Bluetooth users within a range of approximately 10 meters.
4. Tap **OK**.

Create a Bluetooth partnership

A Bluetooth partnership is a relationship that you create between your device and another Bluetooth enabled device in order to exchange information in a secure manner. Creating a partnership between two devices involves entering the same personal identification number (PIN) or Passkey on both devices. Creating a partnership between two devices is a one-time process. Once a partnership is created, the devices can recognize the partnership and exchange information without requiring a PIN. Make sure the two devices are within a range of 10 meters from one another and that Bluetooth is on and discoverable.

1. On the **Today** screen, tap **Start > Settings > Connections tab > Bluetooth**.



2. On the **Devices** tab, tap **Add new device**. Your device searches for other Bluetooth devices and displays them in the box.



3. Tap the desired device name in the box and tap **Next**.



4. Enter a passkey to establish a secure connection. The passkey must be between 1 and 16 characters.
5. Tap **Next**.



6. Enter the same passkey that is entered on the other device. You can, however, edit and enter a new name for the other device.
7. Tap **Finish** after checking the services offered by the other Bluetooth device.



Accept a Bluetooth partnership

1. Ensure that Bluetooth is turned on and discoverable.
2. Tap **Yes** when prompted to establish a partnership with the other device.
3. Enter a passkey (the same passkey that is entered on the device requesting the partnership) to establish a secure connection. The passkey must be between 1 and 16 characters.
4. Tap **Next**.
5. Tap **Finish**. You can now exchange information with the other device.

Rename a Bluetooth partnership

1. On the **Today** screen, tap **Start > Settings > Connections** tab > **Bluetooth**.
2. Tap and hold the partnership on the **Devices** tab.
3. On the shortcut menu, tap **Edit**.
4. Enter a new name for the partnership.
5. Tap **Save**.

Delete a Bluetooth partnership

1. On the **Today** screen, tap **Start > Settings > Connections** tab > **Bluetooth**.
2. Tap and hold the partnership on the **Devices** tab.
3. Tap **Delete** from the shortcut menu.



4.4 Beams

The term Beam is used to describe the short range transferring of information between two units via Bluetooth. An example of beaming could be sending the details of a contact to another Windows Mobile device.

By default, the option to receive incoming beams is disabled for security and battery conservation. Make sure that **Receive All Incoming beams** is enabled in **Start > Settings > Connections > Beam**.



Beam an item

In the **Calendar**, **Contacts**, **Notes**, **Tasks** and **Pictures** programs, you can beam files and information to other devices using Bluetooth.

1. From the program, select the item you want to beam, such as an appointment in **Calendar**, a task in **Tasks**, a contact card in **Contacts**, or a picture in **Pictures**. In **Calendar**, first open the appointment in **Agenda view**.
2. Different applications have different ways of beaming:
 - In **Calendar**, tap **Menu** > **Beam**.
 - In **Contacts**, tap **Menu** > **Send Contact** > **Beam**.

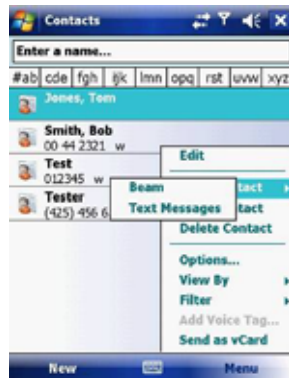

3. Via Bluetooth, select the device to which you want to send the item.
4. Tap on **Tap to Send**.

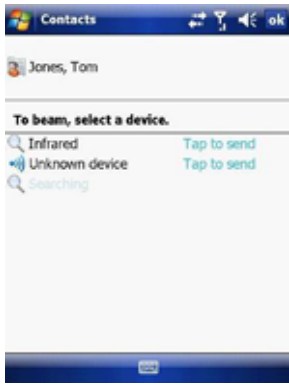

4.5 Connect to a Wireless LAN

Connect to a Wi-Fi network

1. On the **Today** screen, tap **Start > Settings > Connections** tab > **Wireless Manager**. You may also access **Wireless Manager** from the **Today** screen or by pressing the Wi-Fi button on the left side of the device.
2. Press the **Wi-Fi** button to turn the wireless function on and off.



3. When the Wi-Fi function is turned on, the device will start scanning for available networks and will prompt the user to select one. Select whether this network is used to connect to **The Internet** or as a **Work** connection and enter the password for this access point, if requested.

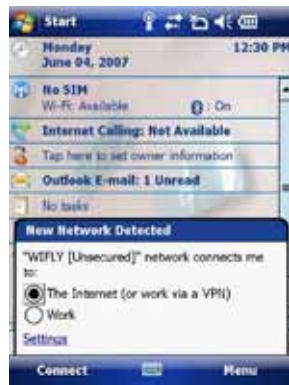

4. To configure the required settings on the **Wireless Manager** screen, tap **Settings** next to each of the wireless functions. When the configuration is completed, you can connect to a Wi-Fi network using your device.

Check Wireless LAN status

You can check the current wireless connection status from the following the screens of your device:

- Tap **Start > Settings > Connections > Wi-Fi** or tapping the  icon on the title bar provides information about the connection status and signal quality for the current connection.



- To manually configure your connection, tap **Start > Settings > Connections tab > Network Cards**. This screen displays the wireless networks currently available and allows you to change the connection settings and create new connections to other access points not broadcasting their **SSIDs**.



On <http://www.clubimate.com> you can find step-by-step guidelines for connecting your device to public and private Wi-Fi access points. Those guidelines are also available in the CD that came with your device.

Chapter 5

5.1 Text Messaging

5.2 MMS

5.3 E-mail

5.4 Windows Live Messenger

This chapter describes how you can create or delete, send or receive, and organize or store your messages in the phone. The following types of messages are all stored under the Messaging Application:

- Text message (SMS - Short Message Service)
- E-mail messages
- Multimedia messages (MMS)

Real-time messaging is also possible on your device by signing into the MSN Messenger application, as explained in this chapter.

5.1 Text Messaging

Text Messaging is a popular way of sending short messages to other mobile phone users and, in some countries, to land lines as well. Each text message is a maximum of 160 characters long. In some countries the maximum size is 70 characters if accents or other special characters are used. Your device will automatically join multiple texts together.

Create a text message

1. On the **Today** screen, tap **Start > Messaging**.
2. Select an account from the list. You are automatically taken to the **Inbox** of the chosen account.
3. From the bottom of the screen, press **Menu > New**.
4. In the **To:** field, enter the mobile phone number of the recipient. Insert a semicolon (;) between multiple recipients. You may also choose a contact by pressing **Menu > Add Recipient**.
5. Tap **Send**. Text messages are sent immediately.

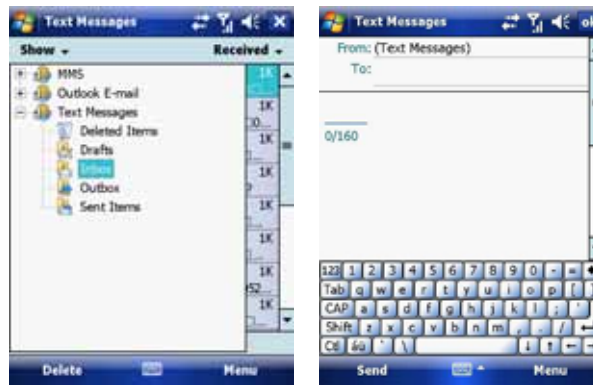

Note: In the **To:** field, you can enter phone numbers from your contact cards quickly. Press the **Action** button when the cursor is in this field. A new screen displays the contact list for your selection. Press the **Action** button again for the selection and the phone returns to the SMS text message screen. Repeat this for all contacts you wish to send the SMS to.

Cancel a text message

To cancel a message, tap **Menu** > **Cancel Message**. If you require Delivery notification, in the message creation screen tap **Menu** > **Message Options...** and check the **Request message delivery notification** box.

Insert predefined text into a message

To save time when entering text, you can insert predefined text into messages.

1. Tap **Menu** > **My Text**.
2. Select the text you want to insert by tapping the phrase you wish to insert.

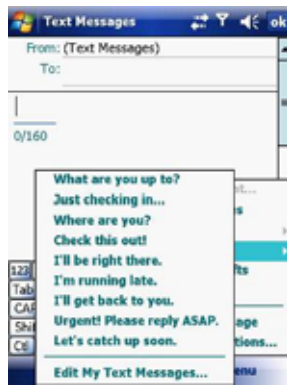

Reply to and Forward a message

1. From the text message inbox tap **Menu** > **Reply** > **Reply All** or from an open message, tap **Reply** (bottom left corner).

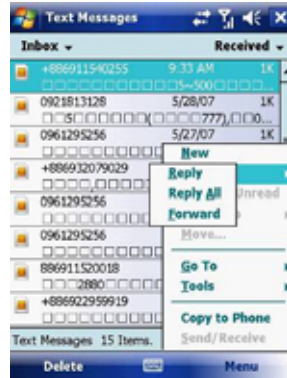

2. Enter a message in the message area.
3. Tap **Send**.

Forward a message

1. From an open message, tap **Menu** > **Reply** > **Forward**.

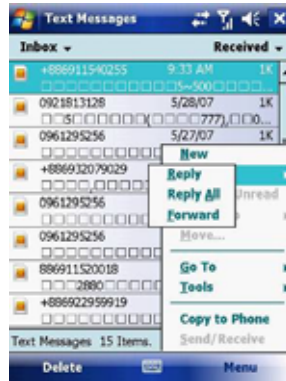

2. Enter a message in the message area.

3. Choose a recipient to send the message to. Type in the name or tap **Menu** > **Add recipient**.

4. Tap **Send**.

Delete a message

1. On the **Today** screen, tap **Start > Messaging** and select an account.
2. Select the message to delete.
3. Tap **Delete** or press the **Left Soft Key**.



5.2 MMS

Creating and sharing MMS messages with your friends and family is easy with your device. You can even use the device's camera to capture photos while composing a new MMS message, and send them along it.

Set up an MMS account

Before you can use MMS, you have to configure the required settings on your device. If your mobile operator settings are recognised by the device when it first boots-up, MMS settings should be set up automatically.

Manually set up an MMS account

To set up your default MMS Messaging account, tap **Start > Messaging > MMS**.

1. Tap **Menu > Options > Accounts tab > MMS**.
2. Tap the **Servers** tab > **New**.
3. Enter the details of your mobile operator's MMSC.

Manage MMS messages

After configuring the required settings, you can start to compose and manage your MMS messages.

Compose MMS messages

You can compose MMS messages in a combination of various slides, where each slide can consist of a photo, audio or video clip and/or text.

1. Tap **Start > Messaging > MMS**.
2. Tap **Menu > New**. Select either a custom message from your collection or a predefined message.
3. In the **To:** field, enter the recipient's phone number or e-mail address directly, or tap **To**, **Cc**, or **Bcc** to choose a phone number or e-mail address from **Contacts**.
4. Enter a subject for your message.
5. Tap the **Insert** icon to select and send a photo or video clip. By default, it will open the **My Pictures** folder. To navigate to any other folder containing pictures or videos, tap **Show**.
6. Tap the image to insert it. Once selected you may remove the image by pressing and holding the image.

7. Enter text and insert audio clips by tapping the respective areas.
8. Tap **Send** to send the message.

The following icons act as shortcuts to some of the operations on the MMS message screen:

Tap  to preview your message.

Tap  to go to the previous slide.

Tap  to go to the next slide.

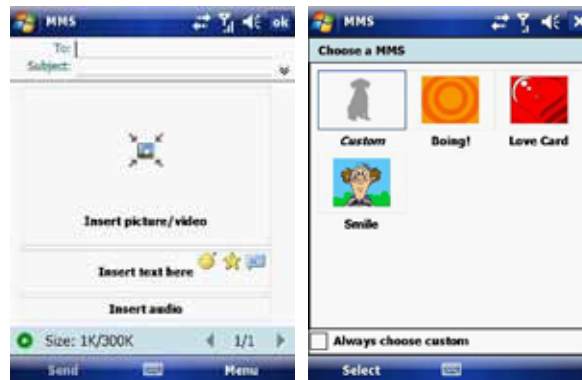

Add an audio clip to an MMS message

You can add audio clips to your MMS message. However, you can add only one audio clip per slide.

1. Tap **Insert audio**. By default, it will open the **My Sounds** folder. To navigate to any other folder containing pictures or videos, tap **Show**.
2. Select an audio file.



Note: To record a new audio clip and add it to your MMS message, tap . This activates the recording control mode for a new audio clip. Tap **Record** to start recording and **Stop** to stop recording. The new audio clip is automatically inserted into your MMS message.

Reply to an MMS message

Tap **Menu** > **Reply** > **Reply** or **Reply All** to reply to the sender of the message, or to all persons listed in **To**, **Cc**, and **Bcc** of the message.

View an MMS message

You can view MMS messages in several ways.

- Use the playback controls ,  and .
- Tap **Objects** to see a list of files included in the message. To save a file, select it and tap **Tools** > **Save**.
- View the slides manually by scrolling through the message using the **Navigation** control.

Set advanced options for an MMS message

From the selected message you can change the following:

- Tap **Menu** > **Options** > **Background** to choose a background colour from the list.
- Tap **Menu** > **Options** > **Text Layout** to align the included text to appear above, below, left or right of the message.
- Tap **Menu** > **Options** > **Text Size** to choose the size of the text.
- Tap **Menu** > **Options** > **Text Color** to choose the text colour from the list.
- Tap **Menu** > **Options** > **Text background** to choose the text background colour from the list.
- Tap **Menu** > **Options** > **Send Options** to set the **Delivery Time** (**1-72 hours** or **Now**), **Expiration** (**1-72 hours** or **Maximum**) and **Priority** (**Low**, **Normal** or **High**). Check the **Delivery report** and **Read report** check boxes to activate them.

Change MMS settings

You can set options to keep track of your messages, retrieve messages immediately, accept or reject messages, and request a delivery or read receipt. You can also specify resolution for the images you send and message delivery attempts, and set up a server to access messages.

Configure MMS settings

1. Tap **Start > Messaging**.
2. Tap **Menu > Options > MMS**.
3. Select any of the following:
 - **Retrieve messages immediately:** Select this check box to download new messages automatically without being notified. (Typically, when you are connected to a network, you receive a notification whenever you receive a new message.) You can also choose to download messages when you are on your home network only.
 - **Confirm to receive messages while roaming:** Receive messages when moving between wireless network sites.
 - **Save sent messages:** Select this check box to save a copy of messages that you send.
 - **Allow read report:** Select this check box to send and receive read reports.
 - **Disconnect network connection after MMS:** Once an MMS message has been sent, disconnect from the network.
 - **Attempts before giving up:** Select a value from this list to limit the number of times the program attempts to send your message.
 - **Photo resolution:** Select a value from this list to choose the resolution for images that you send. Decreasing the original resolution helps speed up the sending and receiving of messages.
 - **Servers:** On this tab, you can create a new server or select an existing one from the list to store and manage your messages. You can also set a server as default by tapping **Set As Default**.

5.3 E-mail

Before you can send or receive e-mails, you will need to setup an e-mail account. There are different types of e-mail accounts supported by the device. This is described in the next few pages.

- Internet e-mail account (POP3/IMAP4).
- Microsoft Exchange Server (Microsoft Outlook).

Set up an Internet e-mail account automatically

1. On the **Today** screen, tap **Start > Messaging > New E-mail Account**.
2. Enter the e-mail address.
3. Check the **Try to get e-mail settings... checkbox**.
4. Tap **Next** to begin searching.



5. If the e-mail address cannot be found, you will be asked to set up the account manually.

Note: If the account is set up successfully, you will be prompted to send and receive e-mail. If not, you must tap **Next** and set up the account manually, which is described in the following pages. You will need to enter your user name and password for your e-mail account.

View the Inbox message list

On the **Today** screen, tap **Start > Messaging**, and select an account. The **Inbox** message list displays your received messages.

Note: To view new messages when they arrive, tap the notification on the **Today** screen.

Create an e-mail message

1. On the **Today** screen, tap **Start > Messaging**.
2. Select an e-mail account from the list.
3. Tap **Menu > New**.
4. In **To**, **Cc**, and/or **Bcc**, enter the recipient's e-mail address. Insert a semicolon (;) between multiple addresses.
5. In **Subject**, enter a subject for the message.
6. Enter a message.
7. Tap **Send**. E-mail messages are stored in the **Outbox** and are sent to recipients the next time you synchronize or connect to your e-mail server and send and receive mail.

Note: You can quickly enter e-mail addresses from your contact cards. In the **To:** field, press **ENTER** and select a recipient from the list. Then, select the recipient's e-mail address. The semicolon separator is automatically inserted if you enter multiple recipients.

- To set the priority of the message (i.e. to make it appear as **Low**, **Normal** or **High** priority in the recipient's inbox), tap **Menu > Message Options**.
- To cancel a message, tap **Menu > Cancel Message**.

Insert predefined text into a message

Please refer to *Section 5.1 Text Messaging* for details on how to use this feature. You can use it when creating a new message or replying to an e-mail. When the message screen appears, tap **Menu > My Text**.

Create and add a signature to message

For each account in **Messaging**, you can specify a signature to be automatically inserted into messages that you send.

1. On the **Today** screen, tap **Start > Messaging**.
2. Select an e-mail account from the list.
3. Tap **Menu > Options > Signatures....**
4. Scroll to the account for which you are creating the signature.
5. Select **Use Signature** with this account.



6. To insert a signature into every message you send, select **Include when replying and forwarding**. Otherwise, a signature is inserted only into new messages.
7. Tap **OK**.

Reply to a message

1. From an open message, tap either the soft-key **Reply** or tap **Menu > Reply > Reply** or **Reply All**.
2. Enter a message in the message area.
3. Tap **Send**.

If you are replying to an e-mail in the Outlook E-mail account, you will send less data if you do not edit the original message. This may reduce data transfer costs, depending on your rate plan.

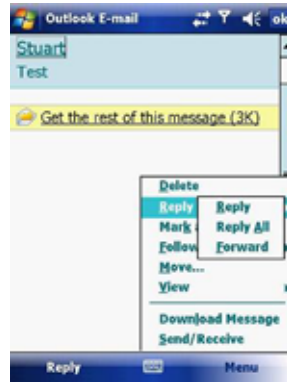

Send and receive Internet e-mail messages

1. On the **Today** screen, tap **Start > Messaging**
2. Select an e-mail account from the list.
3. Tap **Menu > Send/Receive**. The phone should then connect to your e-mail server via the Internet and send/receive your messages.
4. To manage your folders for ActiveSync, tap on **Menu > Tools > Manage Folders**.

Note: To stop this process, tap **Menu > Stop Send/Receive**.

Download a complete e-mail message

1. On the **Today** screen, tap **Start > Messaging**
2. Select an e-mail account from the list.
3. Select the message to download.
4. Tap **Menu > Download Message**. The complete message is retrieved the next time you synchronize or connect to your e-mail server to send and receive e-mail.

Note: Alternatively, you can scroll down to the bottom of the message and tap **Get the rest of this message**. The message will be downloaded the next time your phone connects to the e-mail server to send/receive e-mail. The frequency of this is determined by the schedule setup in your ActiveSync configuration, described in *Chapter 6*.

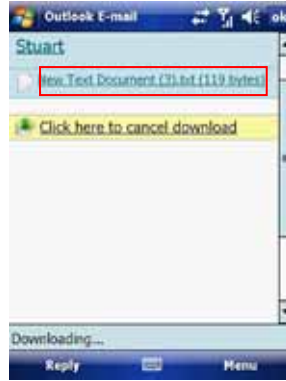

After you scroll down to the file name shown, tap it and the attached file will be downloaded when your phone connects to your e-mail server to send/ receive e-mails again.

View an attachment

In an open message containing a downloaded attachment, tap the attachment.

Note: You can view attachments only for file formats supported by the device.

Digitally sign a message

Digitally signing a message applies your public-key certificate to the message. This proves to the recipient that the message is from you and not from an impostor, and that the message has not been altered.

1. On the **Today** screen, tap **Start > Messaging**.
2. Select an e-mail account from the list.
3. Click **Menu > New**.
4. Click **Menu > Message Options**.

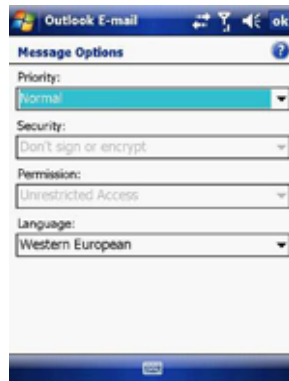

5. From the **Security** list, choose from the drop down menu.
6. Tap **OK**.

Note: S/MIME encryption and digital signatures for Windows Mobile®-based devices are available only with Exchange Server 2003 Service Pack 2 or later versions that support S/MIME. If you are not using one of these products, or have not yet synchronized, these options are unavailable.

Change e-mail folders and accounts

1. On the **Today** screen, tap **Start > Messaging**
2. Select an e-mail account from the list.
3. Tap **Go To > Folders**.
4. You can select the new folder you wish to view.
5. To manage your folders for ActiveSync, tap **Menu > Tools > Manage Folders**.

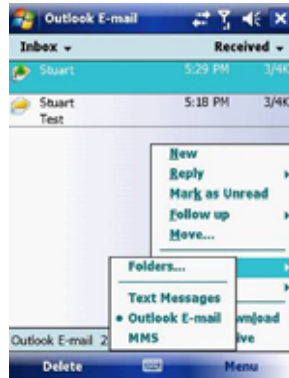

5.4 Windows Live Messenger

Before you can use Windows Live Messenger you must be connected to the Internet.

Pocket MSN Messenger overview

With MSN Messenger you can send instant messages to your contacts' mobile devices or computers. For instructions, select a task below.

Get started with MSN Messenger

To use MSN Messenger, you need Microsoft Passport Network credentials. After obtaining credentials, complete the following tasks:

1. Setup a connection with your phone: refer to *Chapter 4 Getting Connected*. This enables you to connect to the Internet.
2. Setup an MSN Messenger account. For more information, see *Set Up an Account*.
3. Sign in to MSN Messenger. For more information, see *Sign In and Out*.

To obtain a Passport, go to <http://www.passport.com>.

To create a Hotmail account, go to <http://www.hotmail.com>.

Setup an account

Before you can use MSN Messenger, you must set up an instant messaging account. For MSN Messenger service, you must have Microsoft Passport Network credentials or a Hotmail account. To use MSN Messenger, you need to create a connection to the Internet.

1. On the **Today** screen, tap **Start > Messaging > New E-mail Account**.
2. Enter the e-mail address.
3. Check the **Try to get e-mail settings automatically from the Internet** check box.
4. Tap **Next** to begin searching.
5. Once found, you will be taken to **Windows Live**.

Sign In and Out

1. On the **Today** screen, tap **Start > Programs > Messenger** or go to Windows Live, tap **Start > Programs > Windows Live**.
2. Tap **Sign in**.
3. Enter the e-mail address and password for your Microsoft® Passport Network credentials or Hotmail account, and tap **Sign in**.

Note: The phone will only prompt for your **Sign in** account and password the first time you sign in for that account. After successful sign in, you will not be prompted for your **Sign in** details the next time. To switch to a different account, tap **Menu > Switch User**.

Signing in to an account may take several minutes, depending on your connection speed and how busy your mobile network is.

Add and delete Contacts

After you have signed into Messenger, you will be able to perform the functions below.

- To add a contact, tap **Menu > Add New Contact** and then follow the directions on the screen.
1. To delete a contact, select the contact and tap **Menu > Contact options > Remove contact**. Check the boxes to **Block this contact** and/or **Remove this contact from my Windows Live contact list**.
 2. Tap **OK** to permanently delete the contact.

Manage Contacts

- To block a contact from viewing your status and sending you messages, select the contact and tap **Menu > Contact options > Block contact**.
- To unblock a contact, select the blocked contact from the list and tap **Menu > Contact options > Unblock Contact**.

Change your display name and personal message

1. In MSN Messenger, tap **Menu > Change Appearance**.
2. In **My display name** and **Personal message**, enter the name and phrase that you want to display in MSN Messenger. Tap **Done**.

Check your Messenger Status

- Tap the messenger title bar. Your current status is indicated in the list by a bullet point. You can change your status by selecting another description.

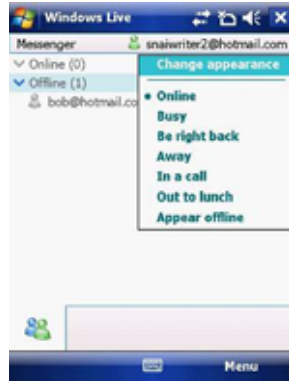

Let Contacts know you are not available

Select your own name at the top of the page and then tap the desired status description. For example, tap **Away**.

Send a message

1. Tap the contact you want to send a message to.
2. Enter your message in the text entry area at the bottom of the screen and tap **Send**.
3. **Emoticons, Pictures, Voice Clips and Files** can also be sent to the contact. Tap **Menu > Add emoticon** or **Menu > Send > Picture, Voice Clip or File**.

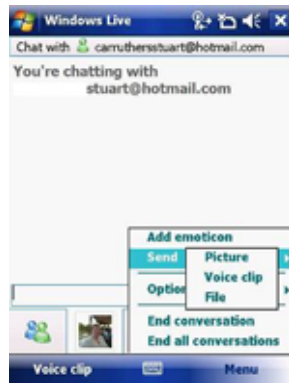

Add Participants

Extra participants can be added to the current conversation.

1. Tap **Menu > Options > Add participant**.
2. Select the contact.
3. Tap **Add**.

End a conversation

- Tap **Menu > End Conversation**.

Chapter 6

6.1 Introduction to ActiveSync

6.2 Install and Configure ActiveSync

6.1 Introduction to ActiveSync

Your device contains ActiveSync software that allows you to create a synchronisation relationship between your mobile device and your PC. This means that when your device is connected to your PC, data is shared between them, according to your preferences. If you make a change in one place, the next time you connect your PC and device, the change is automatically made to the other machine.

You may connect to your PC using a cable or a Bluetooth connection. Accessing files from your PC remotely on your device is also possible using the 1-View component of the i-mate™ Suite. Go to <http://www.imatesuite.com> for more information.

To allow the connection to be made, the ActiveSync software provided on the getting started CD must also be installed on your PC.

Note that upon connecting the device, Windows Vista™ users will be prompted to download Windows Mobile Device Center software and do not require ActiveSync on their PC.

To access e-mails or other Outlook information whilst away from your PC, you may also connect your device to your Microsoft Exchange E-mail server.

This connection may be performed over GPRS, 3G, Wi-Fi or through your PC's connection to the Internet. If your Exchange Server is running Exchange 2003 SP2 or later, you may also be able to receive Push e-mails. Any new e-mails will be sent directly to your device.

6.2 Install and Configure ActiveSync

You can either install ActiveSync from your Windows Mobile Getting started CD or download it from <http://www.microsoft.com>. After the software has been installed and the USB cable is connected between your PC and phone, the ActiveSync setup wizard starts up. Click **Next** to continue.



If you only intend to synchronize directly with your Microsoft Exchange Server and not your PC, select the option below. The alternative is to synchronize your phone with your PC. Note that you cannot do both at the same time while connected to your PC.

Synchronize with Exchange Server

The next few steps explain how to synchronize directly with Exchange Server. If you plan to synchronize with your PC, go to the *Synchronize with your PC* section below.

If you have a PC which is already fully synchronized with your Exchange Server, then synchronize your device to your PC the very first time instead of synchronising to the Exchange Server. This will allow faster synchronisation.

First, check the box **Synchronize directly with a server running Microsoft Exchange Server** and click **Next**.



Complete the details below. Contact your network administrator if you do not know this information.



Ensure that your PC has a connection which is accessible to the Server as the setup will check the connection and your User name and Password setting validity.

To synchronize directly through to your Exchange Server instead of your PC, click the box above and enter the Exchange Server details, as shown below:



You can view additional setting information by selecting an item and clicking **Settings** below. For example, you may choose to synchronize details of your **Calendar** for the past two weeks only.



After you click **Finish**, you should get a screen prompt as below. This needs to be selected as appropriate to your own requirements, depending on the state of your PC. The time required for synchronisation depends on how much data is to be transferred.



Note: Files can only be synchronized with Microsoft Exchange SP 2 or later.

Synchronize with your PC

First you must choose a name for your PC. If you have more than two synchronisations already established, one must be erased in order to proceed.



After choosing a name, click **Next**.



This window allows you to choose which information to synchronize and which will remain private.



Check the box to maintain wireless connection while the device is plugged into your PC.



To begin the PC Sync, click **Finish** but leave the device plugged in.

Change ActiveSync settings

After setting up synchronisation using the Sync Setup wizard on the PC, the synchronisation settings can subsequently be changed:

- If you want to change ActiveSync settings when synchronising with your PC, use the **Changing the amount of information synchronized** section in the Help files on your PC.
- If you want to change ActiveSync settings for synchronising through to your Exchange Server, use the ActiveSync settings on your device, as described in *Change settings for an information type* below.

Change settings for an information type

Before changing synchronisation settings on the device, first disconnect it from your PC.

1. On the **Today** screen, tap **Start > Programs > ActiveSync > Menu > Options**.
2. Select one of the information types.
 - To view or change settings for an information type (when available), tap **Settings**.
 - To view or change settings for a computer or Exchange Server, tap **Menu > Settings**.

3. Change the amount of information to be synchronized or other settings.
4. Click **Done** (or **Finish** in the Exchange Server settings wizard).

Connect to a PC using Bluetooth

1. Follow the instructions in **ActiveSync Help** on the PC for configuring Bluetooth on your PC to support ActiveSync. Make sure that your PC's Bluetooth is set to **Visible (Discoverable)** and that ActiveSync on the PC has the Bluetooth COM port enabled – see below.
2. From the device's **Today** screen, tap **Start > Programs > ActiveSync**.
3. Tap **Menu > Connect via Bluetooth**. Ensure that the phone and PC are within close range.
4. If this is the first time you have connected to this PC via Bluetooth, you must complete the Bluetooth wizard on the phone and setup a Bluetooth partnership with the PC before synchronising.
5. Tap **Sync**.
6. When finished, tap **Menu > Disconnect Bluetooth**.
7. To preserve battery power, turn off Bluetooth.

Ensure that the PC ActiveSync Serial port corresponds to the PC's Bluetooth Serial port configuration. In the example below, the Bluetooth Serial Port has already been set up as **COM4** by the computer. Because **COM4** is allocated to Bluetooth, the **Allow connections to one of the following** field has been set to **COM4** to match this.



In the sample screenshot below, the PC Bluetooth Manager indicates that the Bluetooth Serial Port is set to **COM4**.



If, for example, you wish to synchronize your phone to the Exchange Server for **E-mail** and **Tasks**, and to your PC for **Contacts** and **Calendar**, tap **Start > Programs > ActiveSync > Menu > Options** from your device and select from the list as shown.



Before connecting your device to your PC, you may first need to check your ActiveSync **Connection Settings** by double clicking on the ActiveSync icons at the bottom right of your PC screen.



When complete, connect your device and synchronisation should take place as below.

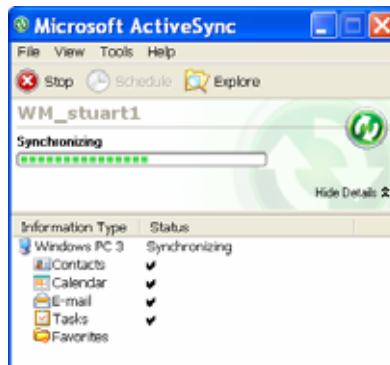

Set up an Exchange Server connection

You can synchronize your **E-mail**, **Calendar Appointments** and **Contacts** directly with your Exchange server. Tasks may also be synchronized if your company is running Exchange Server 2003 SP 2 or later.

To complete this configuration, you will need to get the name of the server and the server domain name from your service provider or system administrator. You must also know your Exchange user name and password.

Note: Before changing synchronisation settings on the phone, disconnect it from your PC. You can also refer to some of the screenshots in the previous section of *Install and Setup ActiveSync* (with Exchange Server).

1. On the **Today** Screen, tap **Start > Programs > ActiveSync > Menu > Configure Server**. If you have not yet set up ActiveSync with Exchange Server, it will say **Add Server Source**.
2. In **Server Address**, enter the name of the server running Exchange Server and click **Next**.
3. Enter your user name, password and domain name and click **Next**. If you want the phone to save your password so that you will not need to enter it again when connecting, select the **Save password** checkbox.
4. Select the check boxes for the types of information items that you want to synchronize with Exchange Server.
5. To change available synchronisation settings, select the type of information and tap **Menu > Settings**.
6. To change the rules for resolving synchronisation conflicts, tap **Menu > Advanced**.
7. Tap **Finish**.

Start and stop synchronisation

1. On the **Today** screen, tap **Start > Programs > ActiveSync**.
2. To start synchronisation, tap **Sync**.
3. To stop synchronising, tap **Stop**.

Note: This menu only appears during synchronisation.



Synchronize your Music and Video files

Your device is able to synchronize music and video files from your PC. This is described in detail in *Chapter 7*.

Chapter 7

7.1 Contacts

7.2 Calendar

7.3 Tasks

7.4 Camera and Video Recorder

7.5 Pictures and Videos

7.6 Windows Media Player

7.7 Internet Explorer Mobile

7.8 Java

7.9 Wireless Manager

7.10 Notes

7.11 Office Mobile

7.12 Internet Sharing

7.13 File Explorer

7.14 Windows Live

7.15 Remote Desktop Mobile

7.16 ClearVue PDF

7.17 Voice Speed Dial

7.18 FM Radio

7.19 Monitor and Projector Connection

7.20 Nyditot Virtual display

7.21 Add More Programs to your device

Introduction

Your Windows Mobile Pocket PC Edition device contains several applications to make you more productive at home, in the office or on the move.

Your device comes with mobile versions of Microsoft Office Word Mobile, Excel Mobile, Outlook Mobile and PowerPoint Mobile, as well as Windows Media Player Mobile.

You can also take pictures, shoot video, record notes and use Java applications using the built-in programs.

This chapter will guide you through use of these applications and let you know how to add more.

7.1 Contacts

Contacts is your address book and information storage for the people and businesses you communicate with. Store home numbers and addresses, e-mail addresses and any other information that relates to a contact, such as a birthday or anniversary date. You can also add a picture or assign a ringtone to a contact.

From the contact list, you can quickly communicate with people. Tap a contact in the list for a summary of contact information. From there, you can call or send a message to that contact.

If you use Outlook on your PC, you can synchronize contacts between your device and PC. If you have synchronized your contacts with an Exchange Server, then your contacts will be updated there too. In the list of contact information, you'll see where you can add a picture or assign a ringtone to a contact.

Create a contact

1. Tap **Start > Contacts**.
2. Tap **New**.
3. Enter contact information. When finished, tap **OK**.

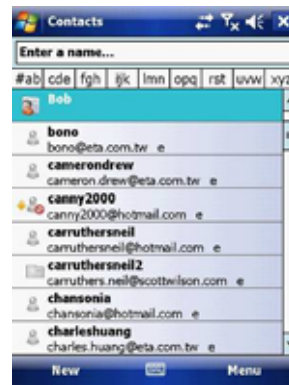

Note: If someone not in your list of contacts calls or sends you a message, you can create a contact from **Call History** or from the message by tapping **Menu > Save to Contacts**.

Change contact information

1. Tap **Start > Contacts**.
2. Tap the contact.
3. Tap **Menu > Edit** and enter the changes.
4. When finished, tap **OK**.

Work with the contact list

There are several ways to use and customise the contact list. Here are a few:

1. Tap **Start > Contacts**.
2. In the contact list, do any of the following:
 - In name view, you can search for a contact by entering a name or number, or by using the alphabetical index. To switch to name view, tap **Menu > View By > Name**.
 - To see a list of available actions for a contact, tap and hold the contact.
 - To see a list of contacts employed by a specific company, tap **Menu > View By > Company**. Then, tap the company name.

Find a contact

There are several ways to find a contact:

1. Tap **Start > Contacts**.
2. If you are not in name view, tap **Menu > View By > Name**.
3. Do one of the following:
 - Begin entering a name or phone number in the provided textbox until the contact you want is displayed. To show all contacts again, tap the textbox and clear the text, or tap the arrow to the right of the textbox.
 - Use the alphabetical index displayed at the top of the contact list.
 - Filter the list by categories. In the contact list, tap **Menu > Filter**. Then tap a category you've assigned to a contact. To show all contacts again, select **All Contacts**.

7.2 Calendar

Use **Calendar** to schedule appointments such as meetings and other events. Your appointments for the day can be displayed on the **Today** screen. If you use Microsoft Outlook on your PC, you can synchronize appointments between your device and PC. If you synchronize your calendar over your cellular connection to your e-mail account, it will also be kept up to date.

You can also set **Calendar** to remind you of appointments through methods such as a sound or flashing light. You can look at your appointments in several different views (**Day**, **Week**, **Month**, **Year**, and **Agenda**).



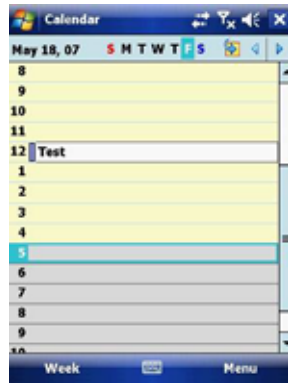

To see detailed appointment information in any view, tap the appointment.

To schedule an appointment

1. Tap **Start > Calendar**.
2. Tap **Menu > New Appointment**.
3. Enter a name for the appointment, and enter information such as start and end times.
4. To schedule an all-day event, in the **All Day** box, tap **Yes**.
5. When finished, tap **OK** to return to the calendar.



Note: All-day events do not occupy blocks of time in **Calendar**. Instead, they appear in banners at the top of the calendar. To cancel an appointment, tap the appointment and then tap **Menu > Delete Appointment**. To have the time entered automatically in Day view, tap the time slot for the new appointment, and tap **Menu > New Appointment**.

Send a meeting request

Use **Calendar** to schedule meetings via e-mail with contacts who use Microsoft Outlook or Outlook Mobile.

1. Tap **Start > Calendar**.
2. Schedule a new appointment or open an existing one and tap **Edit**.
3. Tap **Attendees**.
4. Tap **Required Attendees** and/or **Optional Attendees**.
5. Tap the name of the contact you want to invite.
6. To invite each additional attendee, tap **Add** and tap the name.
7. Tap **OK**.
8. The meeting request will be sent to the attendees the next time you synchronize your device with your PC.

Note: When attendees accept your meeting request, the meeting is automatically added to their schedules. When their response is sent back to you, your calendar is updated as well.

Set a default reminder for all new appointments

You can have an automatic reminder for all new appointments.

1. Tap **Start > Calendar**.
2. Tap **Menu > Tools > Options > Appointments** tab.
3. Select the **Set reminders for new items** check box.
4. Set the time when you want the reminder to alert you.
5. Tap **OK** to return to the calendar.

7.3 Tasks

Use **Tasks** to keep track of things you need to do. A task can occur once or repeatedly (recurring). You can set reminders for your tasks and you can organise them using categories. Your tasks are displayed in a task list. Overdue tasks are displayed in red.

Create a task

1. Tap **Start > Programs > Tasks**.
2. Tap **Menu > New Task** or the **Tap here to add new task** field at the top of the screen. Enter a subject for the task and fill in information such as its start, due date, priority, etc.
3. When finished, tap **OK**.



Note: You can easily create a short to-do type of task. Simply tap the **Tap here to add a new task** box, enter a subject and press **Enter**. If the task entry box is not available, tap **Menu > Options** and select the **Show Tasks entry bar** checkbox.

Change the priority of a task

Before you can sort tasks by priority, you need to specify their priority levels.

1. Tap **Start > Programs > Tasks**.
2. Tap the task you want to change the priority for.
3. Tap **Edit** and in the **Priority** box, tap a priority level.
4. Tap **OK** to return to the task list.

Note: All new tasks are assigned a **Normal** priority by default.

You can have a reminder automatically turned on for all new tasks you create.

1. Tap **Start > Programs > Tasks**.
2. Tap **Menu > Options**.
3. Select the **Set reminders for new items** check box.
4. Tap **OK** to return to the task list.

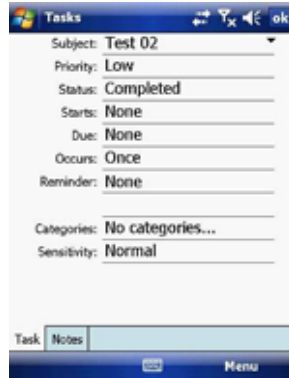

Note: The new tasks must have due dates set in order for the reminder to take effect.

Show start and due dates in the task list

1. Tap **Start > Programs > Tasks**.
2. Tap **Menu > Options**.
3. Select the **Show start and due dates** check box.
4. Tap **OK**.

Filter a task

When your list of tasks is long, you can display a subset of the tasks or sort the list to quickly find a specific task.

1. Tap **Start > Programs > Tasks**.
2. Tap **Menu > Filter > All Tasks, Recently Viewed, No Categories, Active Tasks or Completed Tasks**.



7.4 Camera and Video Recorder

Taking photos and recording video clips with audio is easy with your device's built-in camera.

Start the camera



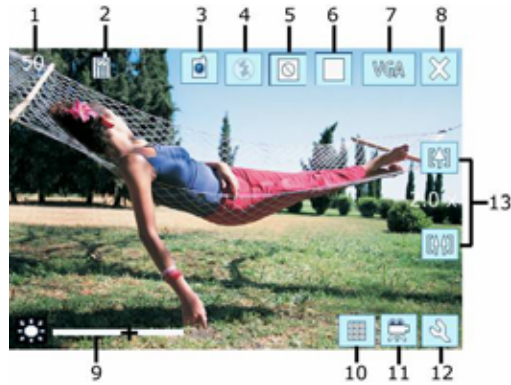

Tap **Start** > **Programs** > **Camera** or press the **Camera** button  on your device.

Camera

By using either the Navigation controller keys or tapping the screen you can adjust the various options.



| No: | Name | Description |
|-----|------------------|--|
| 1 | Number of photos | Show the number of photos that can be captured. |
| 2 | Storage Location | Display the current storage location (Micro SD card or device memory). |
| 3 | Switch Camera | Switch between the front or rear cameras. |

| | | |
|----|-------------------|--|
| 4 | Flash | Switch the flash on or off. |
| 5 | Effects | Switch between None (default), Monochrome (M), Negative (N), Sepia (S) and Posterization (an artistic effect) (P) |
| 6 | Capture Mode | Switch between Normal () , Burst () , Timer () , and MMS () modes. |
| 7 | Photo Resolution | Switch between VGA, 1.3M, 2M, S and QVGA. |
| 8 | Close | Close the application. |
| 9 | Brightness | Push the controller left and right to adjust the brightness. |
| 10 | Pictures & Videos | Launch the Pictures and Videos application. <i>See section 7.5 Pictures & Videos.</i> |
| 11 | Video Mode | Switch between camera and video modes. |
| 12 | Options | View the camera options. |
| 13 | Zoom | Push the controller up and down to adjust the zoom level. |

Taking pictures

Press the **Camera** button on the device to take a picture.

Adjusting Brightness and Zoom

- Press the **Navigation controller** up or down to change the zoom level.
- Press the **Navigation controller** left or right to alter the brightness.



Capture modes

While using Still Image capture modes, such as **Photo**, **Burst** or **Timer**, you can capture still image(s) by pressing the **Camera** or **Action** buttons on the device, or tapping **Capture** on the screen. Still Image capture modes support JPEG.

- Normal: Captures standard still images.
- Burst: Captures a sequence of still images (5 max.) as long as the **Camera** button or **Enter** on the **Navigation controller** is kept pressed.
- Timer: After 10 seconds the picture is taken automatically.

Picture Resolution

Your device is equipped with a 2.0 Megapixel Digital-Effect camera. The larger the number of megapixels, the more detailed the picture will be. However a larger picture means that more data has to be stored, resulting in available memory for other pictures.

To set the resolution of the pictures to be captured, tap the camera options icon or the Photo resolution switch  icon or the Photo resolution switch .

Switching to video mode



Tap the **video mode** icon  to switch to the video mode.

Video

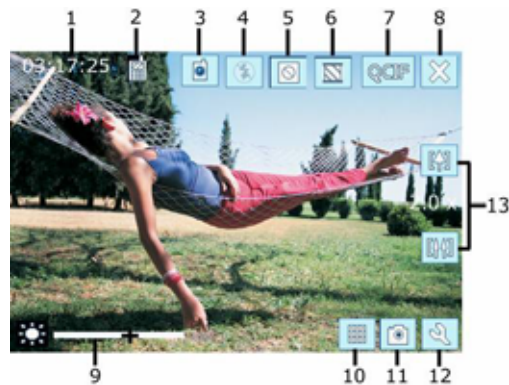
By using either the Navigation controller keys or tapping the screen you can adjust the various options.



| | | |
|---|----------------|--|
| 1 | Recording Time | Display the amount of time the video has |
|---|----------------|--|

| | | |
|----|-------------------|---|
| | | been recording for. |
| 2 | Storage Location | Display the current storage location (Micro SD card or device memory). |
| 3 | Switch Camera | Switch between the front or rear cameras. |
| 4 | Flash | Switch the flash on or off. |
| 5 | Effects | Switch between None (default), Monochrome (M), Negative (N), Sepia (S) and Posterization (an artistic effect) (P) |
| 6 | Recording Mode | Switch between Normal () and MMS () modes. |
| 7 | Video Resolution | Switch between QVGA, and QCIF. |
| 8 | Close | Close the application. |
| 9 | Brightness | Push the controller left and right to adjust the brightness. |
| 10 | Pictures & Videos | Launch the Pictures and Videos application. <i>See section 7.5 Pictures & Videos.</i> |
| 11 | Camera Mode | Switch between camera and video modes. |
| 12 | Options | View the camera options. |
| 13 | Zoom | Push the controller up and down to adjust the zoom level. |

Capturing Video

Your device is capable of recording moving pictures and sound. To enter Video recording mode:

1. Press the **Camera** button or then tap **Start > Programs > Camera**.
2. Tap the video icon .

While using the Video capture mode, you can press the **Camera** button to start recording a video clip (with audio if desired). To stop recording, press the **Camera** button again.

Your device displays the first frame of the captured video clip by default on the **Review** screen. From this screen you will be able to:

- Send the video by e-mail or MMS.
- Delete the video.

- Play the video in Windows Media Player.

Adjusting Brightness and Zoom

- Press the **Navigation controller** up or down to change the zoom level.
- Press the **Navigation controller** left or right to alter the brightness.

Before you capture a video clip, you can specify the recording limit in terms of time and file size on the Camera Settings screen so that the recording stops automatically when the clip size reaches that limit.

Set the limit on the maximum video recorded:

Video is captured by default as a WMV (Windows Media Video) file. This can be played back on your Pocket PC or on a desktop PC.

1. Tap **Menu > Options > Video**.
2. Select from the Time limits for videos: **15 seconds**, **30 seconds** or **No limit**.

Video resolution

You can change the video resolution size between the two below. But as with the *photo resolution*, the larger the resolution the larger the file size.

- QVGA – The larger of the 2 formats provides you with images at 320 x 240 pixels.
- QCIF – Smaller than QVGA at 176 x 144 pixels.

Options

From either camera or video modes tap the  icon.

The Options screen contains four tabs:

| | |
|-------|---|
| Basic | <ul style="list-style-type: none"> • Enable shutter sound – Check this box to play a shutter sound when you take a picture. • Photo file prefix – Begin a photo file name with the name displayed here. • Video file prefix - Begin a video file name with the name displayed here. • Photo quality – From the drop down list choose between Low, Normal or High. • White balance – Change the options depending on the light conditions choose between Auto, Clear Sky, Cloudy, |
|-------|---|

| | |
|-------|--|
| | <p>Incandescent or Fluorescent.</p> <ul style="list-style-type: none"> • Effect – Choose an effect to apply to the image between Normal, Monochrome, Sepia, Negative or Posterization. Or tap the icons in the main screen. • Flicker – Choose the flicker rate of the screen between Auto, 50Hz or 60Hz. • Save file to – Choose to save the recorded image to either the phone or the Micro SD card (if inserted). |
| Photo | <ul style="list-style-type: none"> • Capture mode – Choose between Normal, Timer, Burst or MMS. Or tap the icons in the main screen. • Resolution – Choose the resolution if the photos to be taken. Choose between S(160*120), QVGA(320x240), VGA (640x480), 1.3M(1280x1024 or 2M (1600 x 1200). Or tap the icons in the main screen. Note: the higher the resolution the larger the file size. • Date Imprint – Check the box to insert the date into the photo. |
| Video | <ul style="list-style-type: none"> • Video format – Choose the video format to record video files in, either MPEG4 or H263. • Resolution – Choose the resolution to record in between QCIF (176x144) or QVGA(320x240). Note: the higher the resolution the larger the file size. • Time format – Choose the time format to be displayed either Hours, Minutes and Seconds or Minutes and Seconds. • Record voice – Check the box to activate the microphone when recording video. |
| About | Displays information about the camera application. |

7.5 Pictures & Videos

The **Pictures & Videos** program collects, organises and sorts images and video clips in the following formats on your device.

| File Type | File Extensions |
|-----------|-----------------------|
| Image | *.jpg, *.gif, *.bmp |
| Video | *.wmv, *.3gp, *.mpeg4 |

You can view the pictures as a slide show, beam them to another nearby device, e-mail them, edit them or set them as the background on the **Today** screen.

Copy a picture or video clip to your device

You can copy pictures from your PC and view them on your device.

- Connect your device to your PC using ActiveSync. You can find out more about how to do this in *Chapter 6*. Then drag the images from your PC and place them in the **My Pictures** folder on your Pocket PC.

For more information about copying files from your PC to your device, see ActiveSync Help on your PC.

Note: You can also copy pictures from your PC to your device using a memory card. Insert the memory card into the memory card slot on your device and then copy the pictures from your PC to the folder you created on the memory card.

View pictures

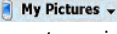
1. Tap **Start > Programs > Pictures & Videos**. The images in the **My Pictures** folder appear as thumbnails by default.
2. Select a picture and tap **View**. If you cannot find a picture in the default **My Pictures** folder, go to another folder by tapping the  icon. A list of other folders will be displayed. Click on a folder name to navigate to access it. This folder will become the default folder the next time you access the **Pictures** icon.

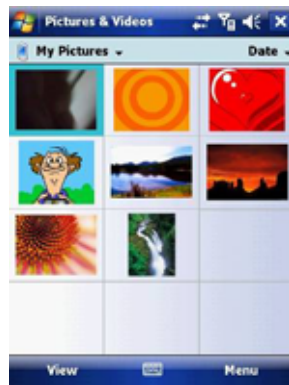

Play videos with audio

1. Tap **Start > Programs > Pictures & Videos**. The video files in the **My Pictures** folder appear as thumbnails by default, which appear with a media icon (🎵).
2. Select a video and tap the thumbnail to play it with the built-in Windows Media Player.

View slide shows

You can view your pictures as a slide show on your device. Pictures are shown in full screen view with 5-second intervals between slides.

1. Tap **Start > Programs > Pictures & Videos**.
2. Tap **Menu > Play Slide Show**.
 - Tap anywhere on the screen to display the **Slide Show** toolbar, which you can use to stop or pause the slide show, rotate the view and more.
 - Press the **Navigation controller** right or left to move forward or backward through the slides.

Note: You can specify how pictures are scaled to optimize their display in a slide show. Tap **Menu > Options > Portrait Pictures** or **Landscape Pictures** on the **Slide Show** tab.

Sort pictures and video clips

If you store a large number of pictures or video clips on your device, you may find it helpful to sort them to quickly find a specific picture or clip. You can sort by **Name**, **Date** and **Size**.

1. Tap **Start > Programs > Pictures & Videos**.
2. Tap the sort list (upper right hand corner) which is labeled **Date** by default and select the item that you want to sort by.

Delete a picture or video clip

Do any of the following to remove a picture or a video clip:

1. Highlight a picture or video clip on the **Pictures & Videos** screen and tap **Menu > Delete**. Or Tap and hold the thumbnail of the picture you want to delete, then tap **Delete**.
2. Tap **Yes** to confirm the deletion.

Edit a picture or video clip

You can rotate, crop and adjust the brightness and colour contrast of your pictures.

1. Tap **Start > Programs > Pictures & Videos**.
2. Tap the picture you want to edit.
3. Tap **Menu > Edit**, and do any of the following:
 - To rotate a picture 90 degrees anticlockwise, tap **Rotate**.
 - To crop a picture, tap **Menu > Crop**. Then, tap and drag to select the area to crop. Tap outside the box to stop cropping.
 - To adjust the brightness and contrast levels of a picture, tap **Menu > AutoCorrect**.
 - To undo an edit, tap **Menu > Undo**. To cancel all unsaved edits you made to the picture, tap **Revert to Saved**.

Set a picture as the Today screen background

You can use a picture as the background on the **Today** screen.

1. Tap **Start > Programs > Pictures & Videos**.
2. Select the picture you want to set as the background.
3. Tap **Menu > Set as Today Background**.
4. In **Transparency Level**, select a higher percentage for a more transparent picture or a lower percentage for a more opacity.
5. Tap **OK**.

Send pictures and video clips via e-mail

You can send pictures and video clips to other devices via e-mail.

1. First, set up messaging to send and receive messages.
2. From **Pictures & Videos**, select the item you want to send.
3. Tap **Send** and select one account (such as Outlook E-mail or MMS) to send the attached item.
4. A new message is created with the item attached.
5. Enter the recipient name, subject and tap **Send**. The message will be sent the next time you synchronize your device.

Note: Pictures and video clips are saved automatically before they are sent.

Assign pictures to contacts

You can assign a picture to a contact. This picture will be shown alongside the contact's name when it is used, such as when you receive a telephone call from the contact or write an e-mail to him/her.

1. Tap **Start > Programs > Pictures & Videos**.
2. Highlight the picture you want to assign to a contact.
3. Tap **Menu > Save to Contact**.
4. Tap the contact or navigate and tap **Select** to choose the contact from your **Contacts** list.

Use advanced options of the Pictures & Videos program

1. Tap **Start > Programs > Pictures & Videos**.
2. Select the picture for which you want to configure further settings.
3. Tap **Menu > Options**. The **Options** screen appears, allowing you to:
 - Resize a picture so that you can send it faster to someone through e-mail.
 - Configure the view settings during slide shows and activate screensaver options.











7.6 Windows Media Player

You can use Microsoft Windows Media Player Mobile for Pocket PC to play digital audio and video files that are stored on your device or on a network. Using Windows Media Player, you can play both audio and video files. These are the file formats that are supported by this version of Windows Media Player.

| Supported File Formats | File Extensions |
|------------------------|-----------------|
| Video | |
| • Windows Media Video | *.wmv |
| • H.263 | *.3gp |
| • MPEG4 | *.mp4 |
| Audio | |
| • Windows Media Audio | *.wma |
| • MP3 | *.mp3 |
| • MIDI | *.mid, *.mid |
| • AMR Narrow Band | *.amr |
| • AAC | *.m4a |

About the controls

The following are available controls on the Windows Media Player. From the Windows Media Player application, for convenience, many of these functions are also available from the Media Control panel on the **Today** screen.

| Icon | Description | Icon | Description |
|--|---|--|---|
|  | Plays a file. |  | Increases the volume. |
|  | Pauses a file. |  | Decreases the volume. |
|  | Skips to the start of the current file or to the previous file. |  | Turns the sound off. |
|  | Skips to the next file. |  | Displays a video by using the entire screen. |
|  | Adjusts the playback progress of a selected file. |  | Displays a website where you can find music and |

| | | | |
|--|--|--|-----------------|
| | | | videos to play. |
|--|--|--|-----------------|

Note: You can rewind and fast-forward files by pressing the **Navigation controller** left or right.

About the screens and menus

Windows Media Player has three primary screens: the **Playback** Screen, the **Library** Screen and the **Now Playing** screen. At the bottom of each screen is an option called Menu. The commands on this menu change depending upon which screen you are viewing.

Playback screen

The default screen that displays the playback controls (such as **Play**, **Pause**, **Next**, **Previous** and **Volume**). If the playback is of an audio file, any album art will be shown in this screen. If the file is a video, it will be shown here. You can change the appearance of this screen by choosing a different skin.

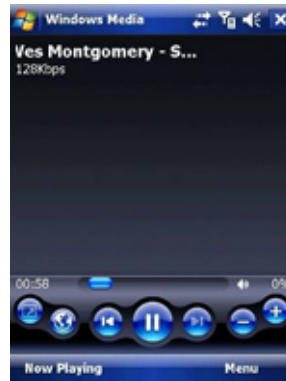

When viewing the **Playback** screen, the following commands appear in **Menu**.

| Command | Description |
|----------------|--|
| Library | Displays the library screen so that you can choose a file to play. |
| Play/Pause | Starts or pauses the playback. |
| Stop | Stops playback. |
| Shuffle/Repeat | Plays the items in the Now Playing playlist randomly / repeatedly. |
| Full Screen | When a video is playing, tapping this will make the playback fill the entire screen. Touch the screen to return to the Playback screen. |
| Options | Lets you adjust various Windows Media Player options including: network, skin and hardware options. |
| Properties | Displays information about the file currently playing. |
| About | Displays information about Windows Media Player such as the version number. |

Now Playing screen menu

The screen that displays the **Now Playing** playlist. This special playlist indicates the currently playing file and any files that are queued to play next.



When you are viewing the **Now Playing** screen, the following commands appear in **Menu**.

| Command | Description |
|----------------------|---|
| Library | Displays the Library screen so that you can choose a file to play. |
| Move Up/Down | Moves the selected item up/down in the playlist order. |
| Remove from Playlist | Deletes the selected item from the playlist. |
| Shuffle/Repeat | Plays the items in the Now Playing playlist randomly/repeatedly. |
| Clear Now Playing | Deletes all items from the Now Playing playlist. |
| Error Details | Displays error information about the selected item (an exclamation mark appears before the item name if error details are available). |
| Properties | Displays information about the selected file. |

Library screen

The screen that lets you quickly find your audio files, video files, and play lists. It contains categories such as **My Music**, **My Video**, **My TV** and **My Playlists**.



When viewing the **Library** screen, the following commands appear in **Menu**.

| Command | Description |
|---------------------|--|
| Queue Up | Adds the selected item to the end of the current (Now Playing) playlist. |
| Delete from Library | Deletes the selected item from the library. |
| Now Playing | Displays the Now Playing screen. |
| Library | Displays the Library screen so you can choose a file to play. |
| Update Library | Adds new items to the library by searching your device or storage card. |
| Open File | Lets you find and play files that are stored on your device or storage card but that are not in the library. |
| Open URL | Lets you play a file on a network, such as the internet. |
| Properties | Displays information about the selected file. |

About licenses and protected files

Some content (such as digital media files downloaded from the internet, CD tracks, and videos) have associated licenses that protect them from being unlawfully distributed or shared. Licenses are created and managed by using digital rights management (DRM), which is the technology for securing content and managing its access rights. Some licenses may prevent you from playing files that have been copied to your device. Files that have licenses associated with them are called "protected files."

If you want to copy a protected file from your PC to your device, use the desktop Player to synchronize the file to your device (instead of dragging the file from a folder on your PC to a folder on your device, for example). This will ensure that the license is copied along with the protected file. For more information about synchronizing files to your device and other mobile devices, see desktop Player Help.

Note: You can view the protection status of a file by checking its file properties. Highlight the file and tap **Menu > Properties**.

Play items on your device

Use the library to find and play songs, videos, and playlists that are stored on your device or removable storage card.

1. If you are not on the **Library** screen, tap **Menu > Library**.
2. On the **Library** screen, tap the Library arrow (near the top of the screen), then tap the library you want to use (such as **My Device** or **Storage Card**).
3. Tap a category (such as **My Music** or **My Playlists**). Tap and hold the item that you want to play (such as a song, album, or artist name) and tap **Play**.

Note: To play a file that is stored on your device but is not in a library, tap **Menu > Open File** on the **Library** screen. Tap and hold the item that you want to play (such as a file or a folder) and then tap **Play**.

Play an item on a network

Use the Open URL command to play a song or video that is stored on the internet or on a network server.

1. If you are not on the **Playback** screen, tap **OK** to close the current screen and display the **Playback** screen.
2. Tap **Menu > Open URL**.
3. Do one of the following:
 - In the **URL** box, enter a network address.
 - In the **History** box, tap a URL that you have previously used.

Note: To play an item on a network, you must be connected to one. For more information about creating a remote connection between your device and a network, see the *Getting Connected* chapter in this manual and **Connections** help on the device.

Copy files to your device

Use the latest version of the desktop Player (Windows Media Player 10 or later) to synchronize digital media files to your device (instead of dragging a file from a folder on your PC to a folder on your device). Using the desktop Player ensures that licenses are copied with protected files.

When synchronizing files, always synchronize them to a storage card that is inserted into your device. Do not synchronize to a storage card that is inserted into a storage card reader. In addition, do not synchronize to the internal

storage location in your device. For more information about synchronizing files to mobile devices, see desktop Player Help on the PC.

Note: Audio files copy faster if the desktop Player is configured to automatically set the quality level for audio files copied to your device. For more information, see desktop Player Help on the PC.

Troubleshooting

If you encounter a problem while using the Windows Media Player, a number of resources are available to help you troubleshoot the issue.

For more information, see the Troubleshooting Windows Media Player Mobile page at the Microsoft website
<http://www.microsoft.com/windows/windowsmedia/player/windowsmobile/troubleshooting.aspx>.

7.7 Internet Explorer Mobile

Internet Explorer Mobile is a full-featured internet browser, optimised for use on your mobile device.

Start Internet Explorer Mobile:

From the **Today** Screen, tap **Start > Internet Explorer**.



Use Internet Explorer

To go to a website, tap in the address bar and enter the address of the site. Tap the green arrow to the right of the address bar to go there, or tap **Go** on the bottom left menu option when you have typed in the new address.

Go to a website using the Favorites list

You can store the websites you want to visit most frequently in the **Favorites** list.

This list can also be synchronized with your PC so that **Favorites** in your PC are also carried with you on your Pocket PC.

Open the Favorites list

In Internet Explorer Mobile, tap **Menu > Favorites**.



Go to a webpage on the Favorites list

Tap on the name of the link to go to that webpage.

Edit the Favorites list

With the Favorites list open, click on the **Add/Delete** tab at the bottom of the screen. You may select links, edit their names, delete them or add new links.

Add the current webpage to the Favorites list

1. Navigate to a page you wish to appear on the **Favorites** list.
2. Tap **Menu > Add to Favorites**.

Transfer favorites from your PC

You can transfer the favourites you have stored on your PC to your device by synchronizing the Internet Explorer favourites on your PC with your device.

1. In ActiveSync on your PC, on the **Tools** menu, click **Options**, and select **Favorites**.
2. In Internet Explorer on your PC, save or move favourite links to the **Mobile Favorites** subfolder in the **Favorites** list.
3. Connect your mobile device to your PC. If synchronization does not start automatically, click **Sync**.

Choose a Homepage

1. In Internet Explorer Mobile, tap **Menu > Tools > Options > General** tab.
2. Do one of the following:
 - To use the displayed page as your Homepage, tap **Use Current**.
 - To use the default Homepage, tap **Use Default**.

Note: To open your Homepage, tap **Menu > Home**.

Change the size of text on web pages

In Internet Explorer Mobile, tap **Menu > View > Text Size** and tap the size you want.

Show or hide pictures on web pages

In Internet Explorer Mobile, tap **Menu > View > Show Pictures**. A check mark next to **Show Pictures** indicates that pictures will be displayed on Web pages.

Change how web pages fill the screen

1. In Internet Explorer Mobile, tap **Menu > View**.
2. Tap one of the following:
 - **One Column:** Arranges the content into one column that is as wide as the screen. This means that you will rarely have to scroll horizontally.
 - **Fit to Screen:** Maintains a layout similar to what you see on a desktop computer, but it makes items smaller and arranges the content so that you can see most of it without having to scroll horizontally.
 - **Desktop:** Keeps the same layout and size as on a desktop computer, which requires both horizontal and vertical scrolling.



Clear the History list

1. In Internet Explorer Mobile, tap **Menu > Tools > Options > Memory** tab.
2. Tap **Clear History**.

Save a picture from a web page

1. In Internet Explorer Mobile, tap and hold the picture, and tap **Save Image**.
2. Do one of the following:
 - To save the picture in My Pictures on your device, tap **Yes**.
 - To save the picture in another location, such as a storage card, tap **Save As**.

Change cookies and security settings

Internet Explorer Mobile supports the protocols used by Secure Sockets Layer (SSL). A connection that uses SSL helps send personal information more safely.

Cookies are small files containing information about your identity and preferences so that a page is tailored with information to suit your needs. The page sends the file and it is stored on your mobile device.

1. In Internet Explorer® Mobile, tap **Menu > Tools > Options > Security** tab.
2. Select the checkboxes for the options you want, and tap **OK**.

Note: To prevent Internet Explorer Mobile from accepting any cookies, clear the **Allow cookies** checkbox.

Delete temporary internet files

Some Web content is stored as you view it to speed up the display of pages you frequently visit or have already seen. You may want to delete these files to free storage space.

1. In Internet Explorer Mobile, tap **Menu > Tools > Options > Memory** tab.
2. Tap **Delete Files**. All pages stored on your device, including offline favourite's content, will be deleted.

Note: To end a GPRS session go to: **Start > Settings > Connections** tab > **Wireless Manager > GPRS Turn Off**.

7.8 Java

MIDlets are Java applications that can run on mobile devices. Your device supports Java 2 Micro Edition, J2ME. The Java software allows you to download Java applications, such as games and tools that are specifically designed for mobile devices. This gives you the flexibility of installing and managing additional J2ME applications from the internet.

Install MIDlets from the internet

1. Locate the MIDlet / MIDlet suite while connected to the internet.
2. Select the MIDlet / MIDlet suite to download.
3. Confirm to start downloading.
4. Run the file(s) to install.

Note: You can cancel the installation at any time.

Install MIDlets from a PC

You can install the MIDlets / MIDlet suites on your device from a PC using the USB cable or Bluetooth. MIDlets copied to your device using Bluetooth or e-mail attachments are automatically saved in the **My Documents** folder.

However, you can copy the MIDlet file(s) from a PC to any of the following temporary folders on your device from where MIDlet Manager can install them.

1. Device memory: /My device/My Documents/My MIDlets.
2. Storage card: /My device/Storage Card.

Note: If the My **MIDlets** folder does not exist in **My Documents**, you can create one with the same folder name. However, a folder named Storage Card automatically appears after you insert a storage card into your device.

Install a MIDlet / MIDlet suite

1. Tap **Start > Programs > MIDlet Manager > Menu > Install > Local** to install the MIDlets currently saved on your phone, or **Browse** to search the internet for midlets.
2. Select the MIDlet / MIDlet suite from the list by using the **Navigation controller**.
3. Tap **Install**.
4. Tap **OK** to install.
5. Tap **Continue** to confirm the installation.

Note: To remove MIDlet files from the temporary folder, tap **Delete** from the shortcut menu.

Run MIDlets on your device

1. Tap **Start > Programs > MIDlet Manager**.
2. Select a MIDlet from the list by using the **Navigation controller**.
3. Press the **Action** button to run the MIDlet.

Manage MIDlets

You can organise MIDlets into folders in order to find them easily:

1. Click **All** on the top left.
2. Arrange by **All**, **Recent** or **Running**.

Change the display name of a MIDlet

1. Tap **Start > Programs > MIDlet Manager**.
2. Select a MIDlet by using the **Navigation controller**.
3. Tap and hold to open the secondary menu.
4. Select **Rename**.
5. Enter the new name.
6. Tap **OK**.

Note: You cannot change the name of a MIDlet suite.

Uninstall a MIDlet

1. On the **MIDlet Manager** screen, tap and hold on a MIDlet in order to open the secondary Menu.
2. Tap **Uninstall > OK**.

Note: You cannot uninstall a single MIDlet from a MIDlet suite; you must uninstall the complete MIDlet suite.

Configure MIDlet security

You can adjust security settings for each MIDlet / MIDlet suite.

1. Tap and hold on a MIDlet in order to open the secondary menu.



2. Configure security options such as **Local Connectivity**, **Net Access** and **App Auto Run**.

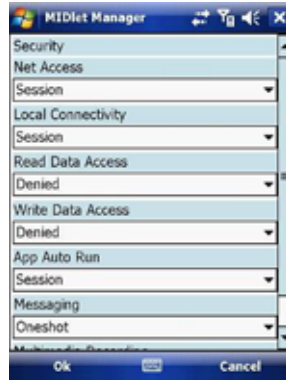

Below are security options that you can set for a running MIDlet / MIDlet suite.

| Security Option | Description |
|------------------------|---|
| Net Access | Determines whether a MIDlet / MIDlet suite can access the internet. |
| Local Connectivity | Enables a MIDlet / MIDlet suite to access services such as Bluetooth. |
| App Auto Run | Enables a MIDlet / MIDlet suite to run at specified times or anytime. |

7.9 Wireless Manager

Wireless Manager is an integrated interface that combines **Bluetooth**, **Wi-Fi**, and **Phone** functions into one page. To manage these wireless connections, tap **Start > Settings > Connections tab > Wireless Manager**. You may also access **Wireless Manager** from the **Today** screen.



Note: Tap **All Wireless Turn On/All Wireless Turn Off** to turn on/off all wireless connections. If you only want to turn one connection, such as Bluetooth, tap **Bluetooth Turn Off**. Tap **Settings** to set up the individual wireless connections.

7.10 Notes

Notes help you quickly capture thoughts, questions, reminders, to-do lists, and meeting notes. You can create handwritten and typed notes, record voice notes, convert handwritten notes to text for easy readability and send notes to others.

Enter information in Notes

There are several ways to enter information in a note. You can enter text using the onscreen keyboard or handwriting recognition software. You can also use the stylus to write or draw on the screen. On devices that support recording, you can create a standalone recording or embed a recording in a note.

Set the default input mode for Notes

If you frequently add drawings to your notes, you may find it helpful to set **Writing** as the default input mode. If you prefer typed text, select **Typing**.

1. Tap **Start > Programs > Notes**.
2. In the note list, tap **Menu > Options**.
3. In the **Default mode** box, tap one of the following:
 - **Writing** if you want to draw or enter handwritten text in a note.
 - **Typing** if you want to create a typed note.
4. Tap **OK**.

Create a note

1. Tap **Start > Programs > Notes > New**.
2. Tap the **Input Selection** arrow next to the **Input Method** icon on the menu bar, tap the input method you want, and enter your text.
3. If the **Input Selection** arrow is not displayed, tap the **Input Method** icon.
4. When finished, tap **OK** to return to the note list.



7.11 Office Mobile

Office mobile is a suite of mobile Microsoft applications. These applications (Excel Mobile, PowerPoint Mobile and Word Mobile) are cut down versions of the full package available for PCs. Access Office Mobile by tapping **Start > Office Mobile**.

Microsoft Word Mobile

Microsoft Word Mobile is a pocket version of Microsoft Word. Word documents created on your PC can be opened and edited on your device. You can also create and edit documents and templates in Microsoft Word Mobile and save them as *.doc, *.rtf, *.txt, and *.dot files.

You can have only one document open at a time. When you open a second document, the first one is saved and closed automatically.

When you close a newly created document, it is automatically named after the first several words in the document and placed in the Word Mobile document list. You can easily rename the document with a more meaningful name and move it to another folder or a storage card.

Run Microsoft Word Mobile

- Tap **Start > Office Mobile > Word Mobile**.



Create a new document

Tap **Menu** > **File** > **New**.

Send a document

To send to another device nearby, you may use Bluetooth beaming.

1. Tap the file you would like to send to another device.
2. Go to **Menu** > **File** > **Beam...**
3. Select the device to which you want to beam the file.

Send via a messaging account

You may send the file via e-mail or MMS to another user.

1. Tap the file you would like to send out.
2. Tap **Menu** > **File** > **Send via E-mail**.
3. Choose the account from which you wish to send the file (e.g. Outlook, Hotmail, MMS, etc).
4. Type in the recipient address into the e-mail. The file is already attached.
5. Tap **Send**.

Note: Work in full-screen mode to see as much of your workbook as possible. Tap **View** > **Zoom** and select a percentage so that you can easily read the worksheet.

Unsupported features in Word Mobile

Word Mobile does not fully support some features of Microsoft Word such as revision marks and password protection. Some data and formatting may be lost when you save the document on your device.

The following features are not supported in Word Mobile:

- Backgrounds.
- Shapes and text boxes.
- Artistic page borders.
- Smart tags.
- Metafiles.
- Bidirectional text. While Word Mobile will open documents containing bidirectional text, the indentations and alignment may be displayed and saved incorrectly.
- Password-protected files. Word Mobile cannot open password-protected documents. You must first remove the password protection in Microsoft Word Mobile on the PC if you want to view the document on the device.
- Document protection. Microsoft Word Mobile does not support displaying files that have been protected in Microsoft Word on the PC.

The following features are partially supported by Microsoft Word Mobile:

- Picture bullets.
- Revision marks.
- Table styles.
- Underlining styles. Underlining styles not supported by Microsoft Word Mobile become one of these four supported styles: regular, dotted, wavy or thick/bold/wide.
- Legacy Pocket Word files. You can open *.psw files in Microsoft Word Mobile. However, if you edit a file, you will need to save it in *.doc, *.rtf, *.txt, or *.dot formats.

The following features are not supported on the device. However, they are retained so that when a file is opened on the PC again, they appear as before.

- Footnotes, endnotes, headers, footers.
- Page breaks.
- Lists.
- Fonts and font sizes. Fonts not supported by the device are mapped to the closest font available, although the original font will be listed on the device.

Microsoft Excel Mobile

Microsoft Excel Mobile makes it easy for you to open and edit Excel workbooks and templates created on your PC. You can also create new workbooks and templates on your device.

Run Microsoft Excel Mobile

Tap **Start** > **Office Mobile** > **Excel Mobile**.

The program operates much as the desktop PC version, allowing entry of numbers, formulas, text, sorting and auto filtering.

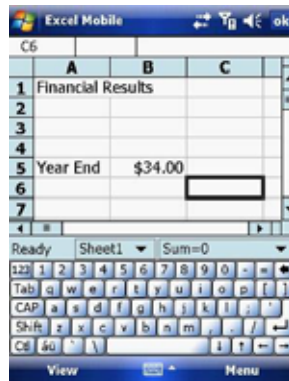

Create a new Workbook

Tap **Menu** > **File** > **New**.

Send a Workbook

To send a workbook to a device nearby, you may use Bluetooth beaming.

1. Tap the file you would like to send to another device.
2. Go to **Menu** > **File** > **Beam...**
3. Select the device to which you want to beam the file.

Send via a messaging account

You may send a file via e-mail or MMS to another user.

1. Tap the file you would like to send.
2. Tap **Menu** > **File** > **Send via E-mail**.
3. Choose the account from which you wish to send the file (e.g. Outlook, Hotmail, MMS, etc).
4. Type the recipient address into the e-mail. The file is already attached.
5. Tap **Send**.

Note: Work in full-screen mode to see as much of your workbook as possible. Tap **View** > **Zoom** and select a percentage so that you can easily read the worksheet.

Unsupported features in Excel Mobile

- Alignment: Horizontal, Vertical, and Wrap-Text attributes remain the same, but vertical text appears horizontal.
- Borders appear as a single line.
- Cell patterns: Patterns applied to cells are removed.
- Fonts and font sizes: Fonts not supported by your device are mapped to the closest font available. The original font is listed on your device. When the workbook is opened on your PC again, data is displayed in the original font.
- Number formats: Numbers formatted using the Microsoft Excel 97 conditional formatting feature are displayed in Number format.
- Formulas and functions: If an Excel file contains a function that is not supported by Excel Mobile, the function is removed. Only the returned value of the function appears. The following formulas are also converted to values: formulas entered as an array or containing an array argument (=SUM({1;2;3;4})), formulas containing external link references or an intersection range reference and formulas containing references past row 16384 are replaced with #REF!
- Protection settings: Most worksheet and workbook protection features are disabled but not removed. However, support for password protection is removed. Workbooks that are password-protected or workbooks in which one or more worksheets are password-protected cannot be opened. You must remove the password protection in Excel on the PC and then synchronize to open the file on the device.
- Zoom settings are not retained. Excel supports a per worksheet zoom setting, while the Excel Mobile zoom setting is applied to the entire workbook.
- Worksheet names: Names that reference worksheets within the same workbook are displayed accurately, but names that refer to other workbooks,

arrays (=A1:A3;B4)), array formulas, or intersection ranges are removed from the name list. If a name is removed from the list, it is left in formulas and functions, causing those formulas to be resolved as "#NAME?". All hidden names are not hidden.

- AutoFilter settings are removed. However, you can use the AutoFilter command in Excel Mobile to perform similar functions. If you have an AutoFilter applied to a worksheet that causes rows to be hidden, the rows remain hidden when the file is opened in Excel Mobile. Use the Unhide command to display the hidden rows.
- Chart formatting. All charts will be saved the way they are shown in Excel Mobile. Unsupported chart types are changed to one of these supported types: Column, Bar, Line, Pie, Scatter, and Area. Background colours, gridlines, data labels, trend lines, shadows, 3D effects, secondary axes, and logarithmic scales are turned off.
- Worksheet features. The following features are not supported in Excel Mobile and are removed or modified when a workbook is opened on the device: hidden sheets are not hidden; VBA modules, macro sheets and dialog sheets are removed and replaced with a place holder sheet; text boxes, drawing objects, pictures, lists, conditional formats, and controls are removed; pivot table data is converted to values.

Microsoft PowerPoint Mobile

With PowerPoint Mobile, you can open and view slideshows created on your PC in *.ppt and *.pps format with PowerPoint '97 and later. Many presentation elements built into the slideshows such as slide transitions and animations will play back on the device. If the presentation is set up as a timed slideshow, one slide will advance to the next automatically. Links to URLs are also supported. PowerPoint features not supported on the device include:

- Notes. Notes written for slides will not be visible.
- Rearranging or editing slides. PowerPoint Mobile is a viewer only.
- File formats. Files created in *.ppt format before PowerPoint 97 and HTML files in *.htm and *.mht formats are not supported.

Start a slideshow presentation

1. Tap **Start > Office Mobile > PowerPoint Mobile**.
2. In the presentation list, tap the slideshow you want to view.
3. Tap the current slide to advance to the next slide.

If the presentation is set up as a timed slide show, slides advance automatically.

Stop a slide show

In a PowerPoint Mobile presentation, tap and hold a slide and tap **End Show**.

Navigate between slides

You can advance to the next slide (if the presentation is not set as a timed slideshow), return to the previous slide or go to any slide out of sequence.

1. Tap **Start > Office Mobile > PowerPoint Mobile**.
2. Open the presentation you want to view.
3. Tap **Next** or **Previous**, or tap **Go to Slide** and tap the slide you want to view.

Tap the current slide to go to the next one.

If you have zoomed in to see a slide in more detail, you cannot navigate to another slide until you zoom out. Tapping **Next** or **Previous** may play an animation on a slide rather than navigate to another slide.

7.12 Internet Sharing

Internet sharing is a way to use your Pocket PC as a cellular modem for your laptop or desktop PC. Here, we provide a brief overview of the subject. You can find step-by-step guidelines for configuring your device for use as a Wireless Modem on <http://www.clubimate.com> and on the Getting Started CD that came with your device.

Note: Your cellular account must already be enabled with a data plan.

Start Internet Sharing

From the **Today** Screen, tap **Start > Programs > Internet Sharing**.



You should choose how you wish to connect your desktop/laptop PC to your Pocket PC.

In the **PC connection** field, choose USB (for a wired connection) or Bluetooth PAN.

Next, you must choose the data connection that you will use to connect to the internet. You can choose this from a drop-down list of all connections that have been configured. If you have not already set up a connection for accessing the internet, please refer to *Chapter 4, Get Connected*.

If you have chosen to connect over USB

1. Tap **Connect** at the bottom of the screen.
2. Now connect your Pocket PC to your computer using the USB cable supplied.
3. Pocket PC Status will show **Connected**. Your PC is now connected to the Internet.



Note: You must run ActiveSync 4.5 or later to use this feature. If you are running an earlier version, upgrade to this using the companion CD that came with your device.

If you have chosen to connect using Bluetooth PAN:

1. You will be prompted about your wish to make your device visible to other users. Click **Yes** if this is the first time that you are setting up the connection.
2. On your PC, perform a Bluetooth Search for the Pocket PC.
3. Follow the process shown on your PC screen to bond it to the Pocket PC.
4. On your PC, go to **Start > Connect to > Show All connections**.
5. Double click the Icon in the Bluetooth Personal Area Network area.
6. Choose to connect the PC to the Pocket PC.

7. Your PC will now be connected to the Internet.

Full further detailed instructions for performing this procedure through Windows XP, running the standard Microsoft Bluetooth stack, can be found at <http://www.clubimate.com> or on the Companion CD that came with your device.

7.13 File Explorer

Your pocket PC has a **File Explorer** application, just like your PC, that allows you to manage files.

Run File Explorer

On the Today Screen go to **Start > Programs > File Explorer**.

You are presented with a list of files and folders inside the current folder. To move up a level, tap **Up**. To go into a folder, click on a folder name.

Copy a file

1. Tap and hold a file name. A menu will then appear.
2. Choose **Copy**.
3. Move to another folder. When you reach the folder where you want the file to be, tap and hold it with the stylus and tap **Paste**. To move the file rather than copy it, select **Cut** in step 2.

E-mail a file

1. Tap and hold on the name of a file.
2. Select the **Send...** option from the menu that appears.
3. Choose an account from which you will send this file.
4. Enter an file addressee and tap **Send**. The file is sent as an attachment.

Delete a file

1. Tap and hold on the name of a file.
2. Select **Delete**.

Create a new folder on the device

1. Move to the directory where you want to create a new directory.
2. Tap **Menu > New Folder**.

View a Web Folder from your device

You can access folders on your corporate intranet.

To do this tap **Menu > Open Path > New Path** and type in the path of the folder on the network. Your device will connect to the Work Connection in order to find the web folder.

7.14 Windows Live

Windows Live enables you to send instant messages and e-mail, search for information, directions, maps and images, and have access to your own space.

Start Windows Live

1. Tap **Start > Programs > Windows Live**
2. Tap **Sign in to Windows Live**. Follow the onscreen instructions.

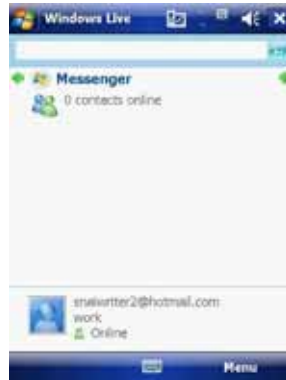

Use the arrows at the top to cycle between **Sync**, **Mail** and **Messenger**.

Options

Tap **Menu > Options**. To see the options below:

| | |
|-------------------------|---|
| 1. Today screen options | Check the boxes to show the Live Search bar and Windows Live services . |
| 2. Sync Options | Selects which options to sync. |
| 3. Sync Schedule | Chooses when to synchronize. |
| 4. Sync Status | Displays when Windows Live was last synchronized. |
| 5. E-mail | Chooses the preview size and check whether or not to send messages immediately. |

| | |
|--------------|---|
| 6. Messenger | Sets the notification types and font and check the box to automatically play voice clips. |
|--------------|---|

Account Options

Tap **Menu** > **Account options**. To see the options below:

| | |
|----------------------|--|
| 1. Clear password | Tap Yes to clear the password. |
| 2. Switch Account | Tap to switch e-mail accounts. |
| 3. Terms of use | Displays the terms of use for Windows Live. |
| 4. Privacy Statement | Displays the Windows Live privacy statement. |

Messenger

See *Chapter 5.4* for details on using messenger services.

Mail

- Tap anywhere on the **Mail** screen to go to the **Mail Inbox**.
- Tap **Menu** to send new e-mails, reply and set the options.

Sync

Display the last sync time and date.

7.15 Remote Desktop Mobile

The remote desktop mobile application is a client that allows you to access your Windows XP Professional desktop from your mobile phone.

Before starting

You need the following things:

1. Install the Windows XP Remote Desktop on the PC you want to remotely access. Click **Start > Settings > Control Panel > System > Remote** tab. Check the **Allow users to connect...** box in **Remote Desktop**. Click **Apply** and **OK**.

Note: See your system administrator or www.Microsoft.com for further help.

2. Connect to the internet through a VPN or use the host computer IP address.

Start Remote Connection

1. Tap **Start > Programs > Remote Desktop Mobile**.
2. Insert the **Computer** name or **IP address**, **User name**, **Password** and **Domain**.
3. Tap **Connect**.



Options

| Tab | Description |
|---------|---|
| Display | Selects the number of colours: 256 or High Color (16 bit) . Check either Full screen or Fit remote desktop to screen . |
| Sound | Choose: Mute , Play on remote computer or Play on this device . |

7.16 ClearVue PDF

ClearVue PDF is a standalone Adobe Acrobat file viewer for your Pocket PC. Use ClearVue PDF to open and view Adobe Acrobat PDF files on your device.

Open a PDF file

1. Launch ClearVue PDF by tapping **Start > Programs > ClearVue PDF**.
2. Tap **File > Open**.
3. Select the folder to browse.
4. View a list of .pdf files, and then tap the file you want to view.

To open a recently opened file, tap **File > Recent Files**.

Move around in a document

When a PDF document is larger than a single screen, you can navigate in the following ways:

- Use scroll bars to move up/down and right/left.
- Use the **navigation** pad to move one line in the desired direction.

The Zoom feature

- The **Zoom** feature allows you to enlarge or reduce the document content on display. **Zoom** is available on the bottom left corner of the screen. Any percentage in the range from 25-200% is valid.
- Select **Page Width** to display the entire width of the page.
- Select **Whole Page** to display the entire page.
- Tap **Zoom > Custom...** to choose your desired percentage of magnification.

7.17 Voice Speed Dial



Voice Speed Dial enables you to record voice tags for contacts or launch programs simply by speaking a single word.

Create a voice tag for a phone number from contacts

1. On the Today screen, tap **Contacts**.
2. Tap and hold the contact listing to add a voice tag. Select the contact > tap **Menu** > **Add Voice Tag** or open the contact and select the phone number and tap **Menu** > **Add Voice Tag**.



Create a voice tag for a phone number or application from Voice Speed Dial

1. Tap **Start** > **Settings** > **Personal** tab > **Voice Speed Dial**.
2. Select the contact from either the **Contact** tab, **SIM** tab or **Application** tab.
3. If adding a tag to a phone number select the phone number.
4. Tap the  icon.
5. Tap the  icon and after the beep record your tag.
6. Once done, a voice tag icon will appear to the right of the number.
 - To re-record the tag, repeat steps 2-4.
 - To delete the tag select the contact on the **Voice Tag** tab and tap the delete  icon,

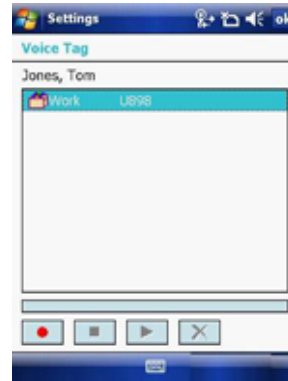

Make a call or launch an application using voice tags

1. Tap **Start > Programs > Voice Speed Dial**.
2. After the beep, say the word that you have assigned to the contact or application.
3. The voice tag will be played back and either dial or launch the application.

Note 1: If no voice tags have been recorded, the device will beep twice and a warning message will be displayed.

Note 2: If the command is not recognised, the device will beep twice and a warning message will be displayed. Reduce the background noise and speak clearly again.

View created voice tags

1. Tap **Start > Settings > Personal tab > Voice Speed Dial > Voice tag** tab.
2. All listed voice tags are displayed.
3. Users can play, record and delete the voice tag. Settings can also be imported and exported by clicking the icons on the right.



7.18 FM Radio

You can listen to **FM Radio** through your device. You can search channels by tapping and holding the rewind and fastforward keys or by tapping **Menu > Channels > Auto search**. This application also allows 100 user-defined favorite groups (each contains up to 18 preset channels), volume control, record button to record audio files and fine-tuned channels.

Note: The FM Radio can be used only when the headset is plugged in (as an external antenna).

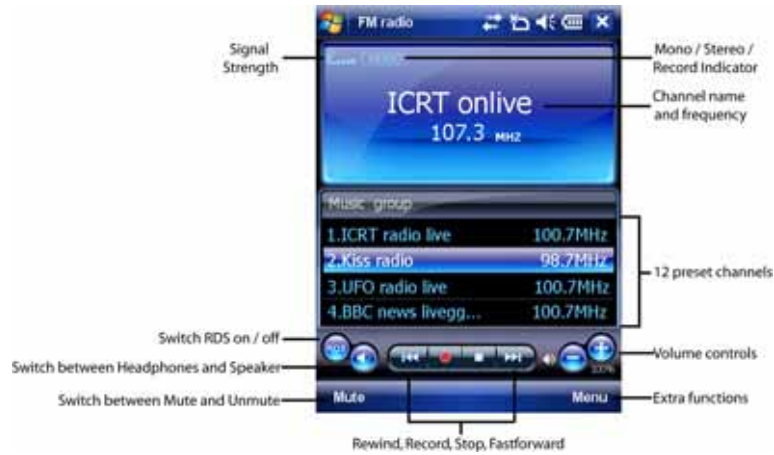

| Item | Description |
|--------------------------------|---|
| Signal Strength | Displays the strength of the radio reception. |
| RDS | If switched on, the Radio Data System identifies the station name, auto retunes and goes to traffic broadcasts. |
| Headphones and speakers | Headphones must be plugged in, but you can listen through headphones or the device speaker. |
| Mute and Unmute | Switch the sound on or off. |
| Volume | Decrease/Increase volume. |

| | |
|-----------------------------------|--|
| Rewind / Fastforward | Use for manual scanning of frequencies. |
| Record | Tap to start recording. |
| Stop | Tap to stop recording or to stop playing an audio file. |
| Mono/Stereo/Record | Tells the user if the radio is in mono, stereo or record modes. |
| Channel name and frequency | The channel name is displayed if RDS is active. The frequency is permanently displayed. |
| Preset Channels | The radio contains 12 preset channels. These can be changed using the auto search function or the rewind and fast forward buttons. |
| Volume controls | Increase and decrease the volume. |
| Menu | Extra functions such as changing channels and audio file play. See below for further details. |

Tap **Menu** to access the following features:

- **Channels** – Automatically search for, save and delete channels.
- **Set frequency** – Manually set the frequency by typing the frequency number.
- **Group** – Create a group of radio channels to listen to.
- **Playback** – Play .wav and .gsm files.
- **Setting** – Use the **General** tab to select the country where you are using the radio (Europe, USA or Australia) and to automatically exit the radio after a set period of time. Use the **Record** tab to choose where to record audio files to and their format (Wav or GSM 610).

7.19 Monitor and Projector Connection

You can connect your phone to monitor or projector to view and present documents. See the image below for an explanation on how to connect the phone to an external device.

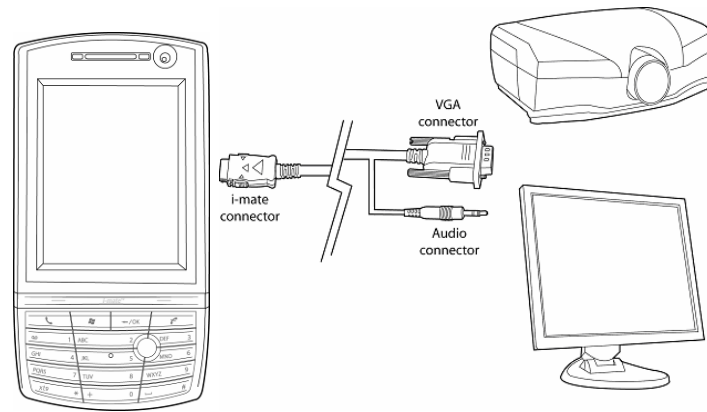

7.20 Nyditot Virtual display

NVD creates a customisable virtual display that can be much larger than the physical display. The physical display becomes a view window into this larger virtual display. The dimensions of the virtual display are limited only by the amount of available memory on your device.

External display

1. Tap **Start > Programs > External Display**.
2. Check/uncheck the **Enable External Display Driver** checkbox to enable/disable the software that controls the External Display.
3. Select the **Output Type (VGA, NTSC, or PAL)** for the External Display or select **Off** to turn off the External Display.
4. In the **Touch Pad Orientation** list, tap the orientation type you want.
5. To change the speed of the mouse pointer when using the internal display as a touch pad or when using an external mouse. Under **Pointer Speed**, move the slider to adjust the speed.
6. Press **Apply** to apply any changes or **OK** to apply changes and exit.

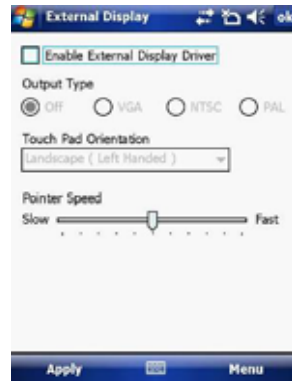

7.21 Add More Programs to your device

You can add more programs to your device by Internet purchase or through a local retailer. Programs may be added using ActiveSync or by installing the memory card that may come with your new purchase.

Chapter 8

8.1 Maintain Your Phone

8.2 Reset Your Phone

8.3 Manage Your Program Memory

8.1 Maintain Your Phone

Your phone is a well-designed and engineered product and the following tips and suggestions will enable you to make the best use of it.

- Keep the phone in a dry environment. If the phone or battery were to get wet due to misuse, this could invalidate the manufacturer's warranty.
- Do not use the phone with wet hands to avoid shocks and risks of water entering in the device, which increases the risks of damage to internal circuits. This also applies if you have to replace the SIM/USIM or micro SD card inside the phone, for whatever reason.
- Keep the phone and its accessories out of reach of young children and pets. They may accidentally damage the phone or run the risk of the smaller components being swallowed.
- Avoid storing the phone in hot environments as high temperatures can shorten the life of electronic components. There is the risk that the plastic casing can warp or melt if the temperature is high enough.
- Also avoid storing the phone in cold environments. When the phone is switched on and warms to its normal operating temperature, moisture can form inside the device, which may damage the circuit boards.
- Avoid dropping or any hard knocks to the phone as they can damage the internal circuit boards.
- If you need to clean the phone, wipe it with a soft clean cloth – avoid the use of cleaning solvents or detergents. **DO NOT** use water to clean the LCD screen.
- Do not attempt to re-spray or paint the phone.
- Do not keep the phone in or near heat sources such as radiators or microwave ovens – this can cause the battery inside the phone to overheat and explode.
- Ensure the volume is turned down if you are using headphones.
- If the phone does not work, carry out some basic troubleshooting checks and try the reset procedures described in the following section. If the problem persists, do not attempt to service or repair the device yourself as this may invalidate the terms of the warranty with the device provider. Repairs should be carried out by an authorised service provider.

8.2 Reset Your Phone

Occasionally, you may need to reset your Pocket PC Phone. A normal (or soft) reset of your device clears all active program memory and shuts down all active programs. This can be useful when the device is running slower than normal or a program is not performing properly. A soft reset is also necessary after the installation of some programs. If a soft reset is performed when programs are running, unsaved work will be lost.

You can also perform a hard reset (also known as a Cold Boot). A hard reset should be performed only if a normal reset does not solve a system problem. After a hard reset, the device is restored to its default settings (the way it was when you first purchased it and turned it on). Any programs you installed, data you entered and settings you customised on the device will be lost. Only Windows Mobile software and other pre-installed programs will remain.

To perform a soft reset

Locate the small hole on the left of the device known as the soft reset button and, using the tip of your stylus, gently push the button inwards. This type of reset will **NOT** affect your data. Otherwise simply remove the battery, wait a few seconds and insert the battery again.

To perform a hard reset

Hard reset by accessing the Master Clear Application:

1. Tap **Start > Settings > System tab > Factory Setting**
2. Proceed to enter the confirmation code: 1234. Confirm by tapping **Yes**. The system will reboot to complete the operation.

Alternatively, a hard reset may be performed using the following process:

1. Simultaneously hold the **Power** button and push the soft reset button inwards.
2. Release the buttons and the device will hard reset.

8.3 Manage Your Program Memory

You may need to stop a program if the program memory is low or if the application stops responding.

To see how much memory is available

1. Tap **Start > Settings > System tab > Memory**.
2. On the **Main** tab, the amount of memory allocated to file and data storage versus program storage is displayed, as well as the amount of memory in use versus the available memory.

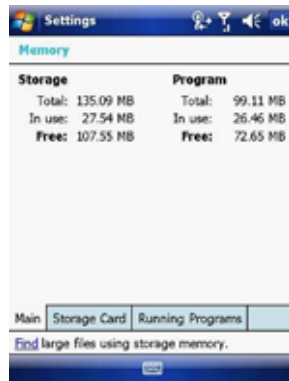

| Storage | Program |
|------------------|------------------|
| Total: 135.09 MB | Total: 99.11 MB |
| In use: 27.54 MB | In use: 26.46 MB |
| Free: 107.55 MB | Free: 72.65 MB |

Main Storage Card Running Programs

[Find large files using storage memory.](#)

Done

To see available storage card memory

You can see how much memory is available on a storage card that is inserted in your device.

1. Tap **Start > Settings > System tab > Memory**.
2. Tap the **Storage Card** tab.



To free up memory

Try the following to free memory on your device:

- Close programs you are not currently using.
- Move e-mail attachments to a storage card.
- Move files to a storage card. Tap **Start > Programs > File Explorer**. Tap and hold the file and tap **Cut**. Browse to the storage card folder and tap **Edit > Paste**.
- Delete unnecessary files. Tap **Start > Programs > File Explorer**. Tap and hold the file and tap **Delete**.
- Delete large files. To find your largest files, tap **Start > Programs > Search**. In the Type list, tap **Larger than 64 KB** and **Search**.
- In Internet Explorer Mobile, delete temporary Internet files and clear history information. For more information, see *Internet Explorer Mobile* in *Chapter 7*.
- Remove programs you no longer use.
- Reset your device.

Appendix

A.1 Battery Information

A.2 PC Requirement to Run ActiveSync 4.5

A.3 Regulatory Notices

A.4 Specifications

A.1 Battery Information

Battery performance depends on many factors, including your wireless service provider's network configuration, signal strength, the temperature of the environment in which you operate your phone, the features and/or settings you select and use, items attached to your device's connecting ports, and your voice, data, and other program usage patterns. The original mains A.C. charger included in the box must be used to charge your device from flat.

Battery life estimates (approximations):

- Talk time: 4 hours/ Standby time: 150 hours.

To check the battery power

- Tap **Start** > **Settings** > **System Tab** > **Power**.
- On the Today screen, tap the battery icon. 

To optimize the power performance

- Tap **Start** > **Settings** > **System Tab** > **Backlight**, and adjust the automatic turn-off feature.



To change a flat battery

- Always use the AC charger supplied in the box

To manage a low battery

1. Immediately save your current date.
2. Plug the AC charger into the device.
3. Synchronize with your PC to charge the device.
4. Turn off your phone.

WARNING! Danger of explosion if battery is incorrectly replaced. To reduce risk of fire or burns, do not disassemble, crush, puncture, short external contacts, expose to temperature above 60 °C (140 °F), or dispose of in fire or water. Replace only with specified batteries. Recycle or dispose of used batteries according to the local regulations or reference guide supplied with your product.



A.2 PC Requirement to Run ActiveSync 4.5

At the time of writing this manual, the requirements for this were published from Microsoft's website for ActiveSync 4.5.
(<http://www.microsoft.com/windowsmobile/activesync/activesync45.msp>)

Supported Operating Systems

- Windows 2000 Service Pack 4;
- Windows Server 2003 Service Pack 1;
- Windows Server 2003 Service Pack 1 for Itanium-based Systems;
- Windows Server 2003, Standard x64 Edition.

For 64-Bit Itanium-Based System

- Windows XP Media Center Edition;
- Windows XP Professional x64 Edition;
- Windows XP Service Pack 1;;
- Windows XP Service Pack 2;
- Windows XP Tablet PC Edition
- Microsoft Outlook XP, Microsoft Outlook 2003 or Microsoft Outlook 2007 messaging and collaboration clients required for synchronization to the desktop or portable computer of e-mail, Calendar, Contacts, Tasks, and Notes. (Outlook 2007 is recommended)
- Microsoft Office XP, Microsoft Office 2003, or Microsoft Office 2007.
- Microsoft Internet Explorer 6. or later. (required)
- Microsoft Systems Management Server 2.0.

The following mobile device operating systems are supported by ActiveSync 4.5:

- Microsoft Windows Mobile 6.0.
- Microsoft Windows Mobile 5.0.
- Messaging and Security Feature Pack for Microsoft Windows Mobile 5.0.
- Microsoft Windows Mobile 2003 Second Edition.
- Microsoft Windows Mobile 2003.

- Microsoft Pocket PC 2002, Microsoft.
- Microsoft Smartphone 2002, Microsoft.

A.3 Regulatory Notices

Agency identification numbers

For regulatory identification purposes, your product (i-mate™ Ultimate) is assigned a model number of 6150.

To ensure continued reliable and safe operation of your Pocket PC, use only the accessories listed in this document.

This product is intended to be used only with an i-mate™ Ultimate approved charger (rated 5V, 1Ah).

European Union Notice

Products with CE marking comply with the R&TTE Directive (95//EC), the EMC Directive (89336//EEC) and the Low Voltage Directive (73213//EEC) issued by the Commission of the European Community.

Compliance with these directives implies conformity to the following European Norms:

- EN 60950-1 (IEC 60950) – Safety of Information Technology Equipment.
- ETSI EN 301 511 V9.0.2 (2003-03) for Mobile communications (GSM); Harmonized standard for mobile stations in the GSM 900 and DCS 1800 bands covering essential requirements under article 3.2 of the R&TTE directive (1995//EC)
- ETSI TS 51 010 – 1V7.0.1 (2006-02) Digital cellular telecommunications system (Phase 2+) Mobile Station (MS) conformance specification; Part 1: Conformance specifications.
- EN 50360-2001 – Product standard to demonstrate the compliance of mobile phones with the basic restrictions related to human exposure to electromagnetic fields (300MHz ~ 3GHz).
- EN 50361-2001 – Basic standard to demonstrate the compliance of mobile phones with the basic restrictions related to human exposure to electromagnetic fields (300MHz ~ 3GHz).
- SAR value: mW/g@10g (CE)
- ETSI EN 301 489-1 Electromagnetic compatibility and Radio spectrum Matters (ERM); ElectroMagnetic Compatibility (EMC) standard for radio equipment and services; Part 1: Common technical requirements.

- ETSI EN 301 489-7 – Electromagnetic compatibility and Radio spectrum Matters (ERM); ElectroMagnetic Compatibility (EMC) for radio equipment and services; Part 7: Specific conditions for mobile and portable radio and ancillary equipment of digital cellular radio telecommunications systems (GSM and DCS).
- ETSI EN 301 489-17 – Electromagnetic compatibility and Radio spectrum Matters (ERM); ElectroMagnetic Compatibility (EMC) for radio equipment and services; Part 17: Specific conditions for 2.4GHz wideband transmission systems.
- ETSI EN 300 208 – Electromagnetic compatibility and Radio spectrum Matters (ERM); Wideband Transmission systems; data transmission equipment operating in the 2.4GHz ISM band and using spread spectrum.



Federal Communications Commission (FCC) Statement

You are cautioned that changes or modifications not expressly approved by the part responsible for compliance could void the user's authority to operate the equipment.

This equipment has been tested and found to comply with the limits for a Class B digital device, pursuant to part 15 of the FCC rules. These limits are designed to provide reasonable protection against harmful interference in a residential installation. This equipment generates, uses and can radiate radio frequency energy and, if not installed and used in accordance with the instructions, may cause harmful interference to radio communications. However, there is no guarantee that interference will not occur in a particular installation. If this equipment does cause harmful interference to radio or television reception, which can be determined by turning the equipment off and on, the user is encouraged to try to correct the interference by one or more of the following measures:

- Reorient or relocate the receiving antenna.
- Increase the separation between the equipment and receiver.
- Connect the equipment into an outlet on a circuit different from that to which

the receiver is connected.

- Consult the dealer or an experienced radio/TV technician for help.

Operation is subject to the following two conditions:

- Device may not cause interference.
- Device must accept any interference, including interference that may cause undesired operation of the device.

FCC RF radiation exposure statement:

For body worn operation, this phone has been tested and meets FCC RF exposure guidelines when used with an accessory that contains no metal and that positions the handset a minimum of 1.5 cm from the body. Use of other accessories may not ensure compliance with FCC RF exposure guidelines."

Important health and safety information

Retain and follow all product safety and operating instructions. Observe all warnings on the product and in the operating instructions.

To reduce the risk of bodily injury, electric shock, fire and damage to the equipment, observe the following precautions.

General precautions

Safety precautions for RF exposure:

Use only original manufacture-approved accessories, or accessories that do not contain any metal.

Use of non-original manufacturer-approved accessories may violate your local RF exposure guidelines and should be avoided.

Safety precautions

- SAFETY IN AIRCRAFT: This product can cause interference to an aircraft's navigation system and network. In most countries it is against the law to use this product on board an airplane.
- ENVIRONMENTAL SAFETY: Do not use this product in gas stations, fuel stores, chemical plants and locations containing explosives.

- **ROAD SAFETY:** Vehicle drivers in motion are not permitted to use handheld telephony services, except in emergency. In some countries, using hands-free devices as an alternative is allowed.
- **MEDICAL EQUIPMENT SAFETY:** This product may cause medical equipment malfunction. In most hospitals or medical centers use of this product is forbidden.

Heed service markings

Except as explained elsewhere in the Operating or Service documentation, do not service any product yourself. Service needed on components inside these compartments should be done by an authorized service technician or provider.

Damage requiring service

Unplug the product from the electrical outlet and refer servicing to an authorized service technician or provider under the following conditions:

- Liquid has been spilled or an object has fallen into the product.
- The product has been exposed to rain or water.
- The product has been dropped or damaged.
- There are noticeable signs of overheating.
- The product does not operate normally when you follow the operating instructions.

Avoid hot areas

The product should be placed away from heat sources such as radiators, heat registers, stoves, or other products (including amplifiers) that produce heat.

Avoid wet areas

Never use the product in a wet location.

Avoid pushing objects into product

Never push objects of any kind into cabinet slots in the product.

Use product with approved equipment

This product should be used only with personal computer and options identified as suitable for use with your equipment.

Cleaning

Unplug the product from the wall outlet before cleaning. Do not use liquid cleaners or aerosol cleaners. Use a damp cloth for cleaning, but **NEVER** use water to clean the LCD screen

SAR information

SAR value: mW/g @ 10g (CE)

Use of non i-mate™ approved accessories may violate RF exposure guidelines and should be avoided.



WEEE Notice

The Directive on Waste Electrical and Electronic Equipment (WEEE), which entered into force as European law on 13th February 2003, resulted in a major change in the treatment of electrical equipment at end-of-life.

The purpose of this Directive is, as a first priority, the prevention of WEEE, and in addition, to promote the reuse, recycling and other forms of recovery of such wastes of as to reduce disposal.

The WEEE logo (shown on the top) on the product or on its box indicates that this product must not be disposed of or dumped with your other household waste. You are liable to dispose of all your electronic or electrical waste equipment by relocating over to the specified collection point of recycling of such hazardous waste. Isolated collection and proper recovery of your electronic and electrical wastes equipment at the time of disposal will allow us to help conserving natural resources. Moreover, proper recycling of the electronic and electrical waste equipment will ensure safety of human health and environment. For more information about electronic and electrical waste equipment disposal, recovery, and collection points, please contact your local city center, household waste disposal service, shop from where you purchased the equipment, or manufacturer of the equipment.

A.4 Specifications

System Information

| | |
|-------------------------|--|
| Processor | Intel PXA 270 520MHz |
| Memory | ROM: 256MB RAM: 128MB |
| Operating system | Microsoft Windows Mobile 6.0 for Pocket PC |

Display

| | |
|--------------------------|--|
| LCD type | 2.6" transmissive TFT-LCD with back-light LEDs, touch-sensitive screen |
| Resolution | 480 x 640 with 262k colour |
| Alignment support | Landscape and Portrait |

Radio Frequency

| | |
|-----------------|-------------------------------|
| GSM/EDGE | Quad band (850/900/1800/1900) |
| GPRS | Class 10 |
| UMTS | Tri band (850/1900/2100) |

Camera

| | |
|---------------------|---|
| Rear camera | 2M pixels camera with flash light, Auto Focus, Digital Zoom |
| Front camera | VGA |
| Resolution | Rear camera: - photo capture: 1600x1200, 1280x960, 640x480, 320x240, 160x120 - video record: 320x240, 176x144 Front camera: - photo capture: 640x480, 320x240 - video record: 320x240, 176x144 |

Physical

| | |
|------------------|---------------------|
| Dimension | 118.5X60.5X15.5 |
| Weight | 152g (with battery) |

Controls and Lights

| | |
|------------------------|---|
| Control buttons | <ul style="list-style-type: none"> - 5-way Navigation pad - Three customisable program buttons: Camera, Wireless Manager, and Start Menu - Two phone functions: Call and End - Start and OK keys - Two soft keys - Jog wheel - Power On/Off button |
| LEDs | Tri-color LED: Red , Green & Blue for GSM standby, Battery charging status, Wi-Fi and Bluetooth status, Notifications, |

Connections

| | |
|------------------|--|
| I/O port | Mini USB 1.1 |
| Wi-Fi | 802.11 b/g/e/i |
| Bluetooth | <ul style="list-style-type: none"> - 2.0 + EDR - Class 2 transmit power - Supported profiles - Generic Access profile - Serial Port profile - Headset profile - Object Push profile - DUN (Dial-Up Networking profile) - Hands-free profile - PAN (Personal Area Network profile) - Generic Object Exchange profile |

| | |
|--------------|---|
| | <ul style="list-style-type: none">- A2DP (Advanced Audio Distribution profile)- AVRCP (Audio/Video Remote Control profile)- HID (Human Interface Device profile)- ActiveSync profile |
| Audio | 10pin mini USB slot for Stereo headset |

Expansion Slot

| | |
|---------------------|-----|
| MicroSD card | Yes |
|---------------------|-----|