



FCC 47 CFR PART 15 SUBPART C

TEST REPORT

For

3.5G Pocket PC Phone

Brand Name: MWG

Model: ZINC II

Issued to

**Arima Communication Corp.
6F, No.866, Jhongjheng Rd., Jhonghe City,
Taipei County 23586, Taiwan**

Issued by

**Compliance Certification Services Inc.
No. 81-1, Lane 210, Bade Rd. 2, Luchu Hsiang,
Taoyuan Hsien, (338) Taiwan, R.O.C.
<http://www.ccsemc.com.tw>
service@tw.ccsemc.com**



Note: This report shall not be reproduced except in full, without the written approval of Compliance Certification Services Inc. This document may be altered or revised by Compliance Certification Services Inc. personnel only, and shall be noted in the revision section of the document.



TABLE OF CONTENTS

- 1. TEST RESULT CERTIFICATION.....3**
- 2. EUT DESCRIPTION4**
- 3. TEST METHODOLOGY5**
 - 3.1 EUT CONFIGURATION5
 - 3.2 EUT EXERCISE.....5
 - 3.3 GENERAL TEST PROCEDURES.....5
 - 3.4 FCC PART 15.205 RESTRICTED BANDS OF OPERATIONS.....6
 - 3.5 DESCRIPTION OF TEST MODES7
- 4. INSTRUMENT CALIBRATION.....8**
 - 4.1 MEASURING INSTRUMENT CALIBRATION.....8
 - 4.2 MEASUREMENT EQUIPMENT USED.....8
- 5. FACILITIES AND ACCREDITATIONS9**
 - 5.1 FACILITIES9
 - 5.2 EQUIPMENT.....9
 - 5.3 TABLE OF ACCREDITATIONS AND LISTINGS.....10
- 6. SETUP OF EQUIPMENT UNDER TEST11**
 - 6.1 SETUP CONFIGURATION OF EUT.....11
 - 6.2 SUPPORT EQUIPMENT.....11
- 7. FCC PART 15.247 REQUIREMENTS.....12**
 - 7.1 PEAK POWER.....12
 - 7.2 AVERAGE POWER.....14
 - 7.3 BAND EDGES MEASUREMENT.....15
 - 7.4 PEAK POWER SPECTRAL DENSITY.....24
 - 7.5 FREQUENCY SEPARATION.....30
 - 7.6 NUMBER OF HOPPING FREQUENCY.....33
 - 7.7 TIME OF OCCUPANCY (DWELL TIME).....36
 - 7.8 SPURIOUS EMISSIONS.....49
 - 7.9 POWERLINE CONDUCTED EMISSIONS.....64
- APPENDIX I RADIO FREQUENCY EXPOSURE.....67**
- APPENDIX II PHOTOGRAPHS OF TEST SETUP.....68**



1. TEST RESULT CERTIFICATION

Applicant: Arima Communication Corp.
6F, No.866, Jhongheng Rd., Jhonghe City,
Taipei County 23586, Taiwan

Equipment Under Test: 3.5G Pocket PC Phone

Brand Name: MWG

Model Number: ZINC II

Date of Test: March 10 ~ 12, 2008

APPLICABLE STANDARDS	
STANDARD	TEST RESULT
FCC 47 CFR Part 15 Subpart C	No non-compliance noted

We hereby certify that:

The above equipment was tested by Compliance Certification Services Inc. The test data, data evaluation, test procedures, and equipment configurations shown in this report were made in accordance with the procedures given in ANSI C63.4: 2003 and the energy emitted by the sample EUT tested as described in this report is in compliance with the requirements of FCC Rules Part 15.207, 15.209, 15.247.

The test results of this report relate only to the tested sample EUT identified in this report.

Approved by:

Reviewed by:

Rex Lai
Section Manager
Compliance Certification Services Inc.

Amanda Wu
Section Manager
Compliance Certification Services Inc.



2. EUT DESCRIPTION

Product	3.5G Pocket PC Phone
Brand Name	MWG
Model Number	ZINC II
Model Discrepancy	N/A
Power Supply	<ol style="list-style-type: none">Power Adapter: PHIHONG / PSAA05R-050 I/P: AC 100-240V, 50-60Hz, 0.3A, 13-16VA O/P: DC 5V, 1A MAXRechargeable Lithium Battery: Model: XP-16 Rating: 3.7V, 1530mAhPowered from Host device via USB cable.
Accessories	<ol style="list-style-type: none">HandsFree: FOXCONN (model name: AC0801001), Unshielded, 1.65 mUSB cable: FOXCONN (model name: CUHD005B-S13-EF), Unshielded, 1.25 m
Frequency Range	2402 ~ 2480 MHz
Transmit Power	-6.23 dBm
Modulation Technique	GFSK for 1Mbps; $\pi/4$ -DQPSK for 2Mbps; 8DPSK for 3Mbps
Transmit Data Rate	1, 2, 3Mbps
Number of Channels	79 Channels
Antenna Specification	Gain: 1.66 dBi
Antenna Designation	PIFA Antenna

Remark:

- The sample selected for test was production product and was provided by manufacturer.*
- This submittal(s) (test report) is intended for FCC ID: **PJO3617** filing to comply with Section 15.207, 15.209 and 15.247 of the FCC Part 15, Subpart C Rules.*



3. TEST METHODOLOGY

The tests documented in this report were performed in accordance with ANSI C63.4 and FCC CFR 47 2.1046, 2.1047, 2.1049, 2.1051, 2.1053, 2.1055, 2.1057, 15.207, 15.209 and 15.247.

3.1 EUT CONFIGURATION

The EUT configuration for testing is installed on RF field strength measurement to meet the Commissions requirement and operating in a manner that intends to maximize its emission characteristics in a continuous normal application.

3.2 EUT EXERCISE

The EUT was operated in the engineering mode to fix the TX frequency that was for the purpose of the measurements.

According to its specifications, the EUT must comply with the requirements of the Section 15.207, 15.209 and 15.247 under the FCC Rules Part 15 Subpart C.

3.3 GENERAL TEST PROCEDURES

Conducted Emissions

The EUT is placed on the turntable, which is 0.8 m above ground plane. According to the requirements in Section 13.1.4.1 of ANSI C63.4 Conducted emissions from the EUT measured in the frequency range between 0.15 MHz and 30MHz using CISPR Quasi-peak and average detector modes.

Radiated Emissions

The EUT is placed on a turn table, which is 0.8 m above ground plane. The turntable shall rotate 360 degrees to determine the position of maximum emission level. EUT is set 3m away from the receiving antenna, which varied from 1m to 4m to find out the highest emission. And also, each emission was to be maximized by changing the polarization of receiving antenna both horizontal and vertical. In order to find out the maximum emissions, exploratory radiated emission measurements were made according to the requirements in Section 13.1.4.1 of ANSI C63.4.



3.4 FCC PART 15.205 RESTRICTED BANDS OF OPERATIONS

(a) Except as shown in paragraph (d) of this section, only spurious emissions are permitted in any of the frequency bands listed below:

MHz	MHz	MHz	GHz
0.090 - 0.110	16.42 - 16.423	399.9 - 410	4.5 - 5.15
¹ 0.495 - 0.505	16.69475 - 16.69525	608 - 614	5.35 - 5.46
2.1735 - 2.1905	16.80425 - 16.80475	960 - 1240	7.25 - 7.75
4.125 - 4.128	25.5 - 25.67	1300 - 1427	8.025 - 8.5
4.17725 - 4.17775	37.5 - 38.25	1435 - 1626.5	9.0 - 9.2
4.20725 - 4.20775	73 - 74.6	1645.5 - 1646.5	9.3 - 9.5
6.215 - 6.218	74.8 - 75.2	1660 - 1710	10.6 - 12.7
6.26775 - 6.26825	108 - 121.94	1718.8 - 1722.2	13.25 - 13.4
6.31175 - 6.31225	123 - 138	2200 - 2300	14.47 - 14.5
8.291 - 8.294	149.9 - 150.05	2310 - 2390	15.35 - 16.2
8.362 - 8.366	156.52475 -	2483.5 - 2500	17.7 - 21.4
8.37625 - 8.38675	156.52525	2655 - 2900	22.01 - 23.12
8.41425 - 8.41475	156.7 - 156.9	3260 - 3267	23.6 - 24.0
12.29 - 12.293	162.0125 - 167.17	3332 - 3339	31.2 - 31.8
12.51975 - 12.52025	167.72 - 173.2	3345.8 - 3358	36.43 - 36.5
12.57675 - 12.57725	240 - 285	3600 - 4400	(²)
13.36 - 13.41	322 - 335.4		

¹ Until February 1, 1999, this restricted band shall be 0.490-0.510 MHz.

² Above 38.6

(b) Except as provided in paragraphs (d) and (e), the field strength of emissions appearing within these frequency bands shall not exceed the limits shown in Section 15.209. At frequencies equal to or less than 1000 MHz, compliance with the limits in Section 15.209 shall be demonstrated using measurement instrumentation employing a CISPR quasi-peak detector. Above 1000 MHz, compliance with the emission limits in Section 15.209 shall be demonstrated based on the average value of the measured emissions. The provisions in Section 15.35 apply to these measurements.



3.5 DESCRIPTION OF TEST MODES

The EUT (model: ZINC II) had been tested under operating condition.

Test program used to control the EUT for staying in continuous transmitting mode was programmed.

Software used to control the EUT for staying in continuous transmitting mode was programmed.

After verification, all tests were carried out with the worst case test modes as shown below except radiated spurious emission below 1GHz and power line conducted emissions below 30MHz, which worst case was in normal link mode only.

The field strength of spurious emission was measured in the following position: EUT stand-up position (Z axis), lie-down position (X, Y axis).

Following channels were selected for the for radiated emission testing only as listed below:

Tested Channel	Modulation Type	Packet Type	Date Rate	Axis
Low, Mid, High	GFSK	DH 5	1	X
Low, Mid, High	8DPSK	DH 5	3	X

The worst emission was found in lie-down position (X axis) for power line conducted emission testing and the worst case was recorded.



4. INSTRUMENT CALIBRATION

4.1 MEASURING INSTRUMENT CALIBRATION

The measuring equipment, which was utilized in performing the tests documented herein, has been calibrated in accordance with the manufacturer's recommendations for utilizing calibration equipment, which is traceable to recognized national standards.

4.2 MEASUREMENT EQUIPMENT USED

Equipment Used for Emissions Measurement

Remark: Each piece of equipment is scheduled for calibration once a year.

Conducted Emissions Test Site				
Name of Equipment	Manufacturer	Model	Serial Number	Calibration Due
Spectrum Analyzer	Agilent	E4446A	MY43360131	01/29/2009
Power Meter	Agilent	E4416A	GB41291611	03/19/2009
Power Sensor	Agilent	E9327A	US40441097	06/07/2008

3M Semi Anechoic Chamber				
Name of Equipment	Manufacturer	Model	Serial Number	Calibration Due
Spectrum Analyzer	Agilent	E4446A	US42510252	09/11/2008
Test Receiver	Rohde&Schwarz	ESCI	100064	11/30/2008
Switch Controller	TRC	Switch Controller	SC94050010	05/04/2008
4 Port Switch	TRC	4 Port Switch	SC94050020	05/04/2008
Horn-Antenna	TRC	HA-0502	06	06/05/2008
Horn-Antenna	TRC	HA-0801	04	06/20/2008
Horn-Antenna	TRC	HA-1201A	01	08/12/2008
Horn-Antenna	TRC	HA-1301A	01	08/12/2008
Bilog- Antenna	Sunol Sciences	JB3	A030205	03/28/2009
Turn Table	Max-Full	MFT-120S	T120S940302	N.C.R.
Antenna Tower	Max-Full	MFA-430	A440940302	N.C.R.
Controller	Max-Full	MF-CM886	CC-C-1F-13	N.C.R.
Site NSA	CCS	N/A	FCC: 965860 IC: IC 6106	09/25/2008
Test S/W	LABVIEW (V 6.1)			

Remark: The measurement uncertainty is less than +/-2.0dB (30MHz ~ 1GHz), +/-3.1dB (Above 1GHz) which is evaluated as per the NAMAS NIS 81 and CISPR/A/291/CDV.

Powerline Conducted Emissions Test Site				
Name of Equipment	Manufacturer	Model	Serial Number	Calibration Due
EMI Test Receiver 9kHz-30MHz	Rohde & Schwarz	ESHS30	828144/003	11/19/2008
Two-Line V-Network 9kHz-30MHz	Schaffner	NNB41	03/10013	06/12/2008
LISN 10kHz-100MHz	EMCO	3825/2	9106-1809	03/31/2009
ISN 9kHz-30MHz	FCC	FCC-TLISN-T4	20167	09/21/2008
Test S/W	LABVIEW (V 6.1)			

Remark: The measurement uncertainty is less than +/- 2.8dB, which is evaluated as per the NAMAS NIS 81 and CISPR/A/291/CDV.



5. FACILITIES AND ACCREDITATIONS

5.1 FACILITIES

All measurement facilities used to collect the measurement data are located at

No.199, Chunghsen Road, Hsintien City, Taipei Hsien, Taiwan, R.O.C.

Tel: 886-2-2217-0894 / Fax: 886-2-2217-1029

No.11, Wugong 6th Rd., Wugu Industrial Park, Taipei Hsien 248, Taiwan

Tel: 886-2-2299-9720 / Fax: 886-2-2298-4045

No.81-1, Lane 210, Bade 2nd Rd., Luchu Hsiang, Taoyuan Hsien 338, Taiwan

Tel: 886-3-324-0332 / Fax: 886-3-324-5235

The sites are constructed in conformance with the requirements of ANSI C63.7, ANSI C63.4 and CISPR Publication 22.

5.2 EQUIPMENT





Radiated emissions are measured with one or more of the following types of linearly polarized antennas: tuned dipole, biconical, log periodic, bi-log, and/or ridged waveguide, horn. Spectrum analyzers with pre-selectors and quasi-peak detectors are used to perform radiated measurements.

Conducted emissions are measured with Line Impedance Stabilization Networks and EMI Test Receivers.

Calibrated wideband preamplifiers, coaxial cables, and coaxial attenuators are also used for making measurements.

All receiving equipment conforms to CISPR Publication 16-1, "Radio Interference Measuring Apparatus and Measurement Methods."

5.3 TABLE OF ACCREDITATIONS AND LISTINGS

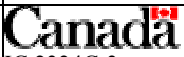
Country	Agency	Scope of Accreditation	Logo
USA	A2LA	EN 55011, EN 55014-1/2, CISPR 11, CISPR 14-1/2, EN 55022, EN 55015, CISPR 22, CISPR 15, AS/NZS 3548, VCCI V3 (2001), CFR 47, FCC Part 15/18, CNS 13783-1, CNS 13439, CNS 13438, CNS 13803, CNS 14115, EN 55024, IEC 801-2, IEC 801-3, IEC 801-4, IEC/EN 61000-3-2, IEC/EN 61000-3-3, IEC/EN 61000-4-2/3/4/5/6/8/11, EN 50081-1/ EN 61000-6-3, EN 50081-2/EN 61000-6-4, EN 50081-2/EN 61000-6-1: 2001	 ACCREDITED TESTING CERT #0824.01
USA	FCC	3/10 meter Open Area Test Sites (93105, 90471) / 3M Semi Anechoic Chamber (965860) to perform FCC Part 15/18 measurements	 93105, 90471 965860
Japan	VCCI	3/10 meter Open Area Test Sites to perform conducted/radiated measurements	VCCI R-393/1066/725/879 C-402/747/912
Norway	NEMKO	EN 50081-1/2, EN 50082-1/2, IEC 61000-6-1/2, EN 50091-2, EN 50130-4, EN 55011, EN 55013, EN 55014-1/2, EN 55015, EN 55022, EN 55024, EN 61000-3-2/3, EN 61326-1, IEC 61000-4-2/3/4/5/6/8/11, EN 60601-1-2, EN 300 328, EN 300 422-2, EN 301 419-1, EN 301 489-01/03/07/08/09/17, EN 301 419-2/3, EN 300 454-2, EN 301 357-2	 ELA 124a ELA 124b ELA 124c
Taiwan	TAF	EN 300 328, EN 300 220-1, EN 300 220-2, EN 300 220-3, 47 CFR FCC Part 15 Subpart C, EN 61000-3-2, EN 61000-3-3, CNS 13439, CNS 13783-1, CNS 14115, CNS 13438, AS/NZS CISPR 22, CNS 13022-1, IEC 61000-4-2/3/4/5/6/8/11, CNS 13022-2/3	 TAF Testing Laboratory 0363
Taiwan	BSMI	CNS 13438, CNS 13783-1, CNS 13439, CNS 14115	 SL2-IS-E-0014 SL2-IN-E-0014 SL2-A1-E-0014 SL2-R1-E-0014 SL2-R2-E-0014 SL2-L1-E-0014
Canada	Industry Canada	3/10 meter Open Area Test Sites (IC 2324C-3, IC 2324C-5) / 3M Semi Anechoic Chamber (IC 6106)	 Canada IC 2324C-3 IC 2324C-5 IC 6106

* No part of this report may be used to claim or imply product endorsement by A2LA or any agency of the US Government.



6. SETUP OF EQUIPMENT UNDER TEST

6.1 SETUP CONFIGURATION OF EUT

See test photographs attached in Appendix II for the actual connections between EUT and support equipment.

6.2 SUPPORT EQUIPMENT

No.	Device Type	Brand	Model	Series No.	FCC ID	Data Cable	Power Cord
1.	Notebook PC	ASUS	M5200AE	5BN0AG019631	PD9WM3B2100	N/A	AC I/P: Unshielded, 1.8m with a core DC O/P: Unshielded, 1.8m

Remark:

1. *All the equipment/cables were placed in the worst-case configuration to maximize the emission during the test.*
2. *Grounding was established in accordance with the manufacturer's requirements and conditions for the intended use.*

7. FCC PART 15.247 REQUIREMENTS

7.1 PEAK POWER

LIMIT

The maximum peak output power of the intentional radiator shall not exceed the following:

1. According to §15.247(a)(1), Frequency hopping systems shall have hopping channel carrier frequencies separated by a minimum of 25 kHz or the 20 dB bandwidth of the hopping channel, whichever is greater. Alternatively, frequency hopping systems operating in the 2400-2483.5 MHz band may have hopping channel carrier frequencies that are separated by 25 kHz or two-thirds of the 20 dB bandwidth of the hopping channel, whichever is greater, provided the systems operate with an output power no greater than 125 mW.
2. According to §15.247(b)(3), for systems using digital modulation in the bands of 902-928 MHz, 2400-2483.5 MHz, and 5725-5850 MHz: 1 Watt.
3. According to §15.247(b)(4), the conducted output power limit specified in paragraph (b) of this section is based on the use of antennas with directional gains that do not exceed 6 dBi. Except as shown in paragraph (c) of this section, if transmitting antennas of directional gain greater than 6 dBi are used, the conducted output power from the intentional radiator shall be reduced below the stated values in paragraphs (b)(1), (b)(2), and (b)(3) of this section, as appropriate, by the amount in dB that the directional gain of the antenna exceeds 6 dBi.

Test Configuration

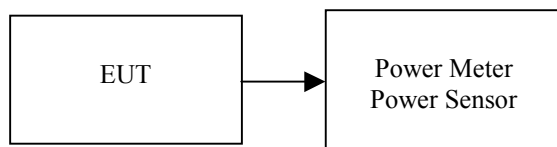

TEST PROCEDURE

The transmitter output is connected to the Power Meter. The Power Meter is set to the peak power detection.



TEST RESULTS

No non-compliance noted

Test Data

For GFSK

Channel	Frequency (MHz)	Output Power (dBm)	Output Power (W)	Limit (W)	Result
Low	2402	-6.23	0.00024	0.125	PASS
Mid	2441	-6.46	0.00023		PASS
High	2480	-6.58	0.00022		PASS

For 8DPSK

Channel	Frequency (MHz)	Output Power (dBm)	Output Power (W)	Limit (W)	Result
Low	2402	-6.58	0.00022	0.125	PASS
Mid	2441	-6.94	0.00020		PASS
High	2480	-7.12	0.00019		PASS



7.2 AVERAGE POWER

LIMIT

None; for reporting purposes only.

Test Configuration

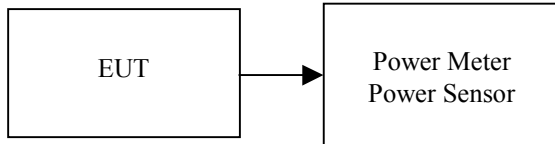

TEST PROCEDURE

The transmitter output is connected to the Power Meter. The Power Meter is set to the average power detection.

TEST RESULTS

No non-compliance noted.

Test Data

For GFSK

Channel	Frequency (MHz)	Output Power (dBm)	Output Power (W)
Low	2402	-7.73	0.00017
Mid	2441	-7.65	0.00017
High	2480	-7.90	0.00016

For 8DPSK

Channel	Frequency (MHz)	Output Power (dBm)	Output Power (W)
Low	2402	-7.61	0.00017
Mid	2441	-7.86	0.00016
High	2480	-8.09	0.00016

7.3 BAND EDGES MEASUREMENT

LIMIT

According to §15.247(d), in any 100 kHz bandwidth outside the frequency bands in which the spread spectrum intentional radiator is operating, the radio frequency power that is produced by the intentional radiator shall be at least 20 dB below that in the 100 kHz bandwidth within the band that contains the highest level of the desired power, based on either an RF conducted or a radiated measurement, provided the transmitter demonstrates compliance with the peak conducted power limits. In addition, radiated emissions which fall in the restricted bands, as defined in §15.205(a), must also comply with the radiated emission limits specified in 15.209(a) (see Section 15.205(c)).

Test Configuration

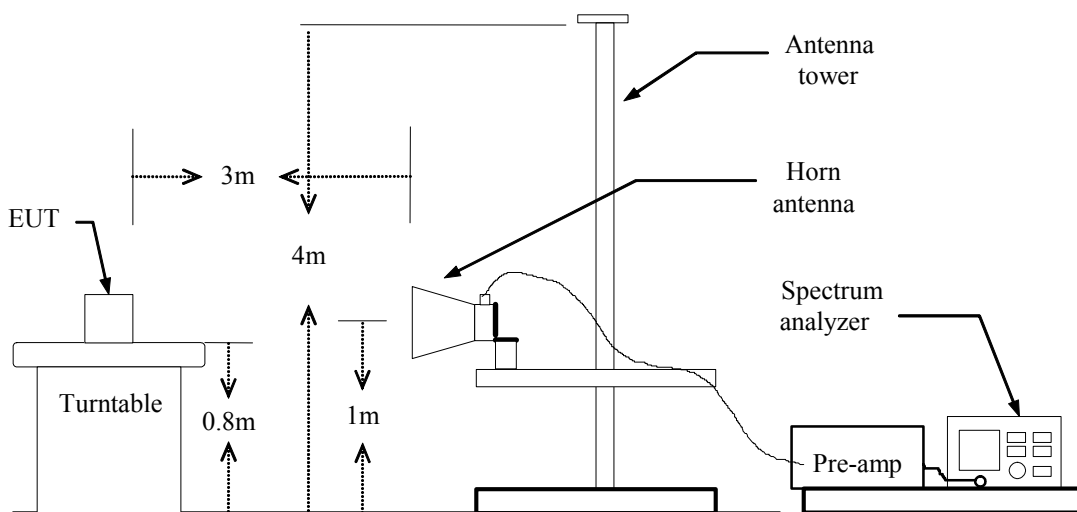

TEST PROCEDURE

1. The EUT is placed on a turntable, which is 0.8m above the ground plane.
2. The turntable shall be rotated for 360 degrees to determine the position of maximum emission level.
3. EUT is set 3m away from the receiving antenna, which is varied from 1m to 4m to find out the highest emission.
4. Set the spectrum analyzer in the following setting in order to capture the lower and upper band-edges of the emission:
 - (a) PEAK: RBW=VBW=1MHz / Sweep=AUTO
 - (b) AVERAGE: RBW=1MHz / VBW=10Hz / Sweep=AUTO
5. Repeat the procedures until all the PEAK and AVERAGE versus POLARIZATION are measured.

TEST RESULTS

Refer to attach spectrum analyzer data chart.



For GFSK

Band Edges (CH Low)

Detector mode: Peak

Polarity: Vertical

Agilent

R T

Mkr1 2.390 00 GHz
54.02 dBµV

Ref 117 dBµV

#Atten 10 dB

Peak
Log
10
dB/
Offst
10
dB
DI
74.0
dBµV
LgAv
M1 S2
S3 FC
A AA
£(f):
FTun
Swp

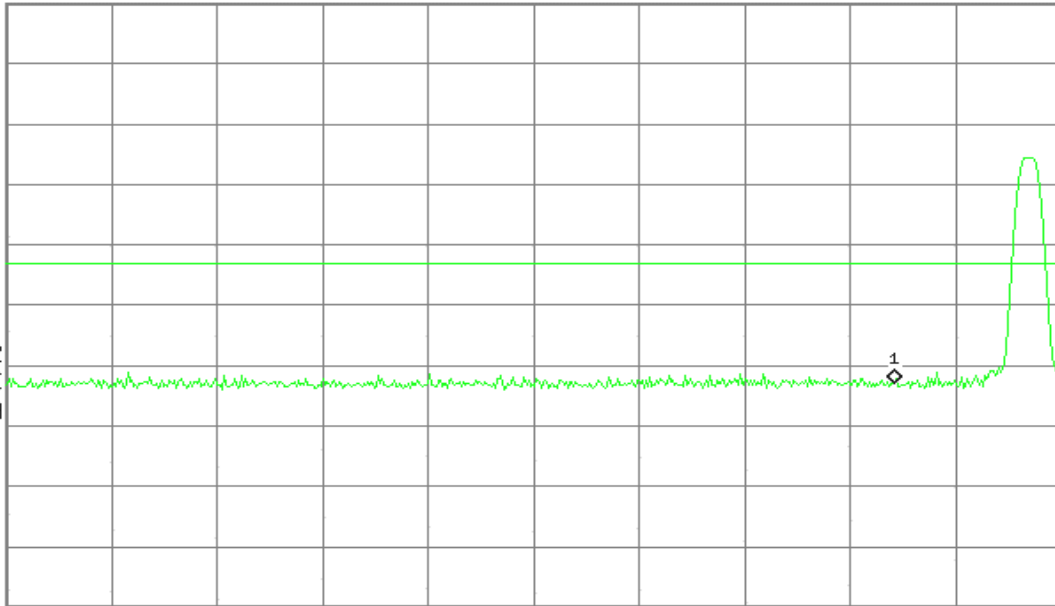

Start 2.310 00 GHz

Stop 2.405 00 GHz

#Res BW 1 MHz

#VBW 1 MHz

#Sweep 100 ms (601 pts)

Detector mode: Average

Polarity: Vertical

Agilent

R T

Mkr1 2.390 00 GHz
41.76 dBµV

Ref 117 dBµV

#Atten 10 dB

Peak
Log
10
dB/
Offst
10
dB
DI
54.0
dBµV
LgAv
M1 S2
S3 FC
A AA
£(f):
FTun
Swp

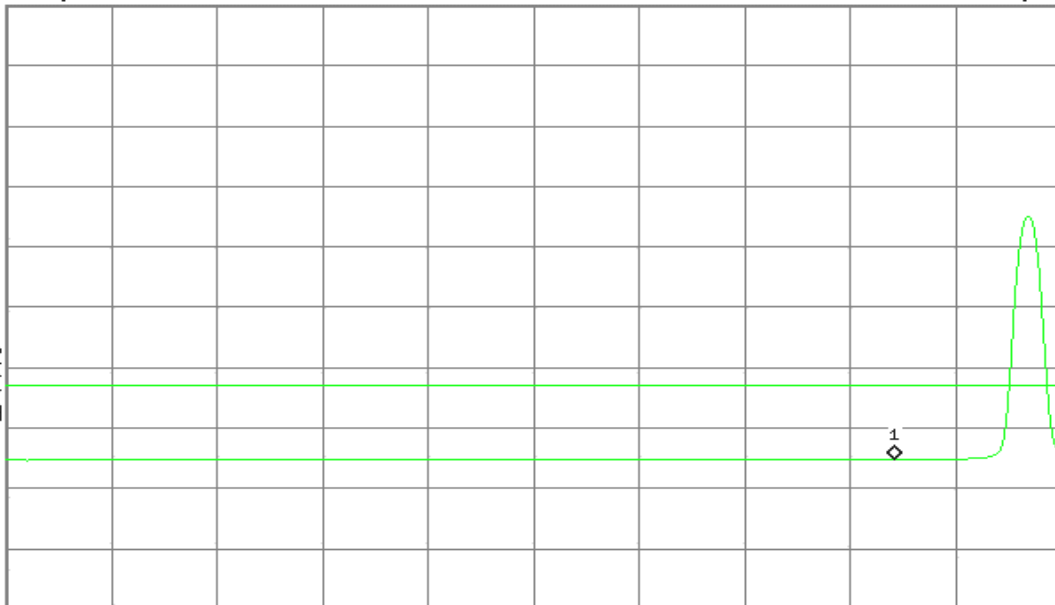

Start 2.310 00 GHz

Stop 2.405 00 GHz

#Res BW 1 MHz

#VBW 10 Hz

Sweep 7.408 s (601 pts)



Detector mode: Peak

Polarity: Horizontal

Agilent

R T

Mkr1 2.390 00 GHz
54.90 dBμV

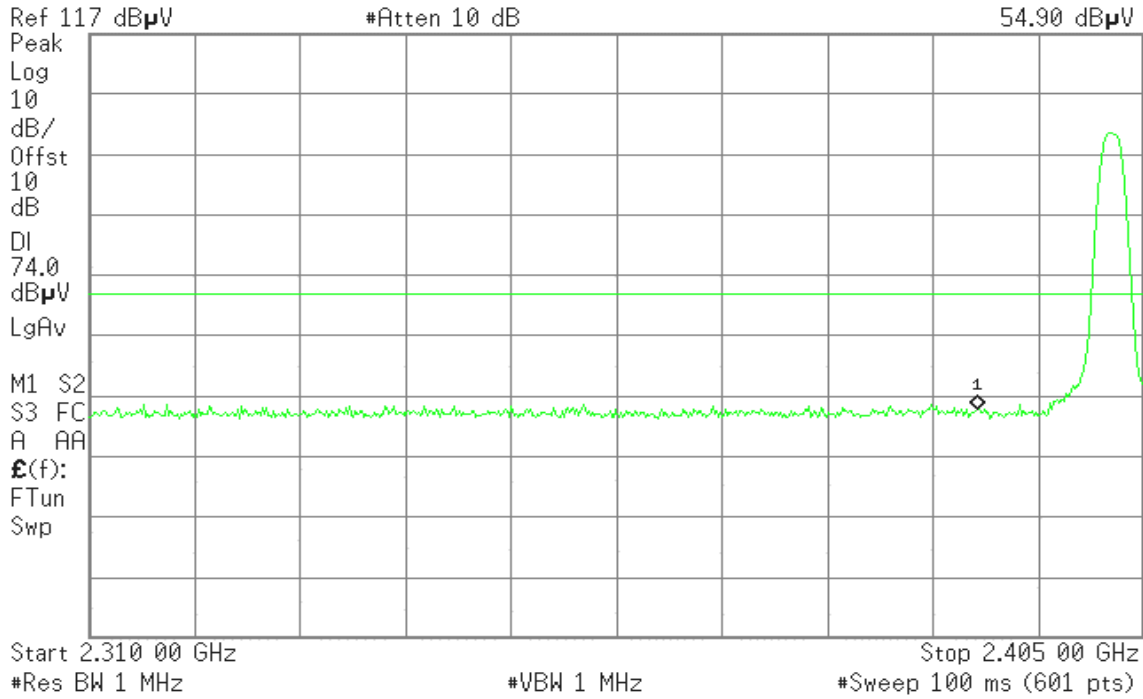

Detector mode: Average

Polarity: Horizontal

Agilent

R T

Mkr1 2.390 00 GHz
42.47 dBμV

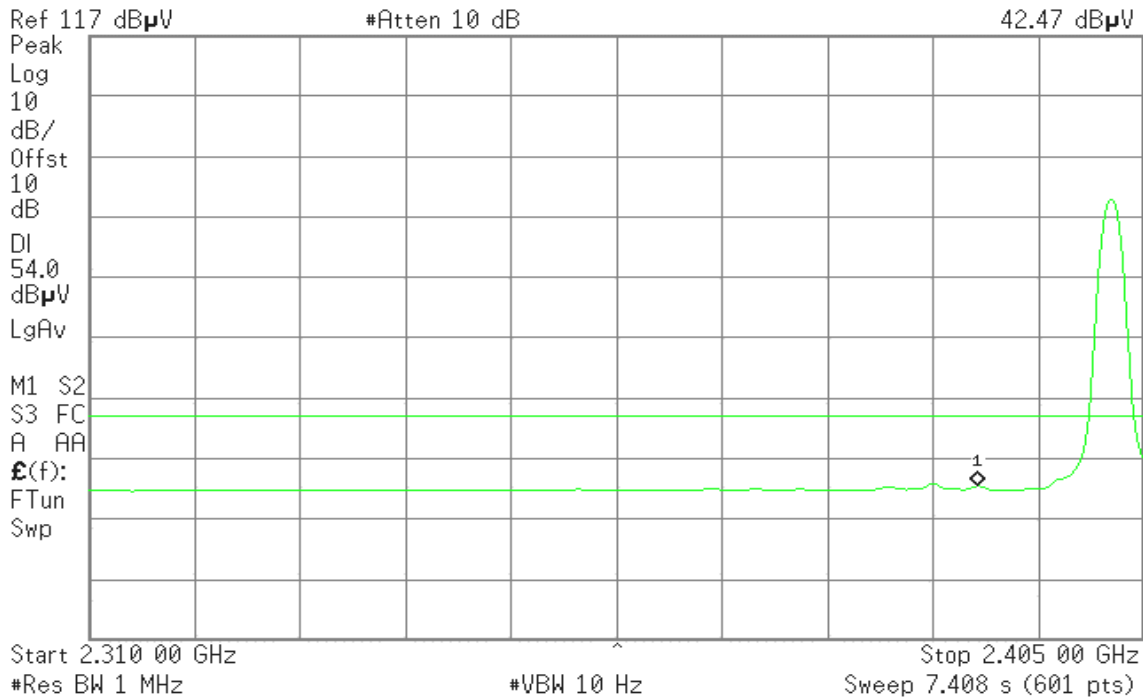



Band Edges (CH High)

Detector mode: Peak

Polarity: Vertical

Agilent

R T

Mkr1 2.483 50 GHz
57.71 dB μ V

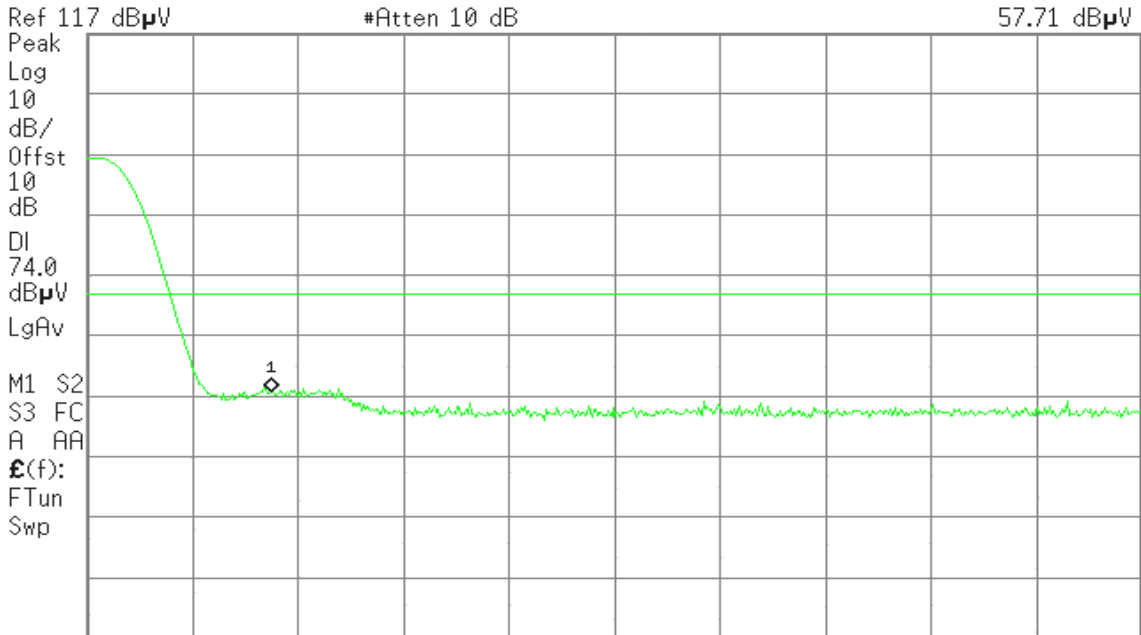

Start 2.480 00 GHz Stop 2.500 00 GHz
#Res BW 1 MHz #VBW 1 MHz #Sweep 100 ms (601 pts)

Detector mode: Average

Polarity: Vertical

Agilent

R T

Mkr1 2.484 07 GHz
46.57 dB μ V

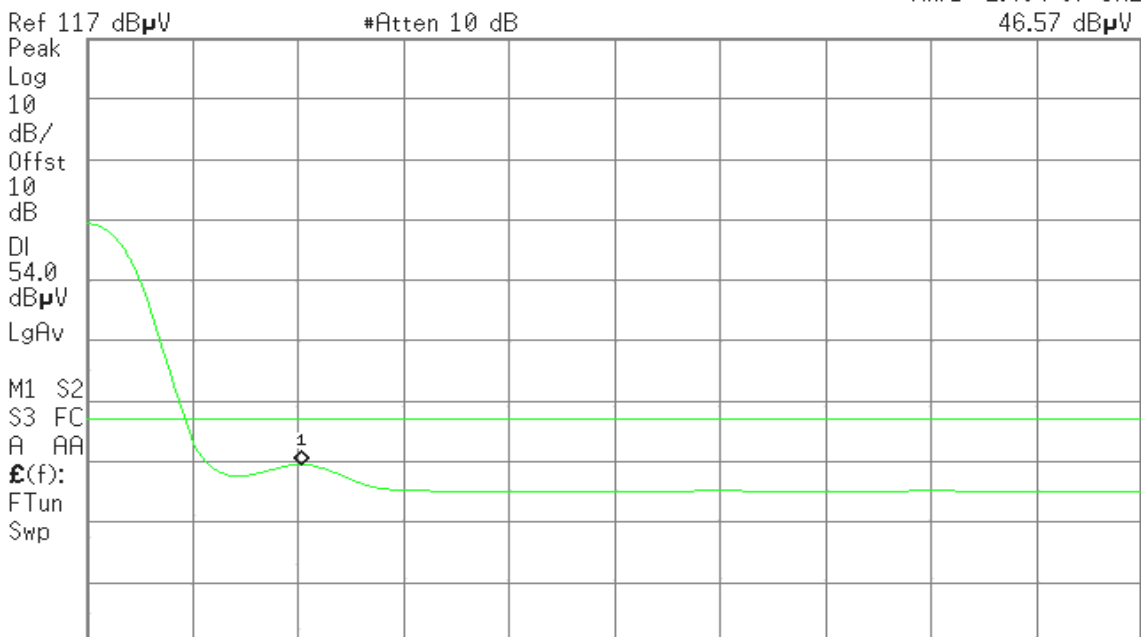

Start 2.480 00 GHz Stop 2.500 00 GHz
#Res BW 1 MHz #VBW 10 Hz Sweep 1.56 s (601 pts)



Detector mode: Peak

Polarity: Horizontal

Agilent

R T

Mkr1 2.483 50 GHz
58.93 dBμV

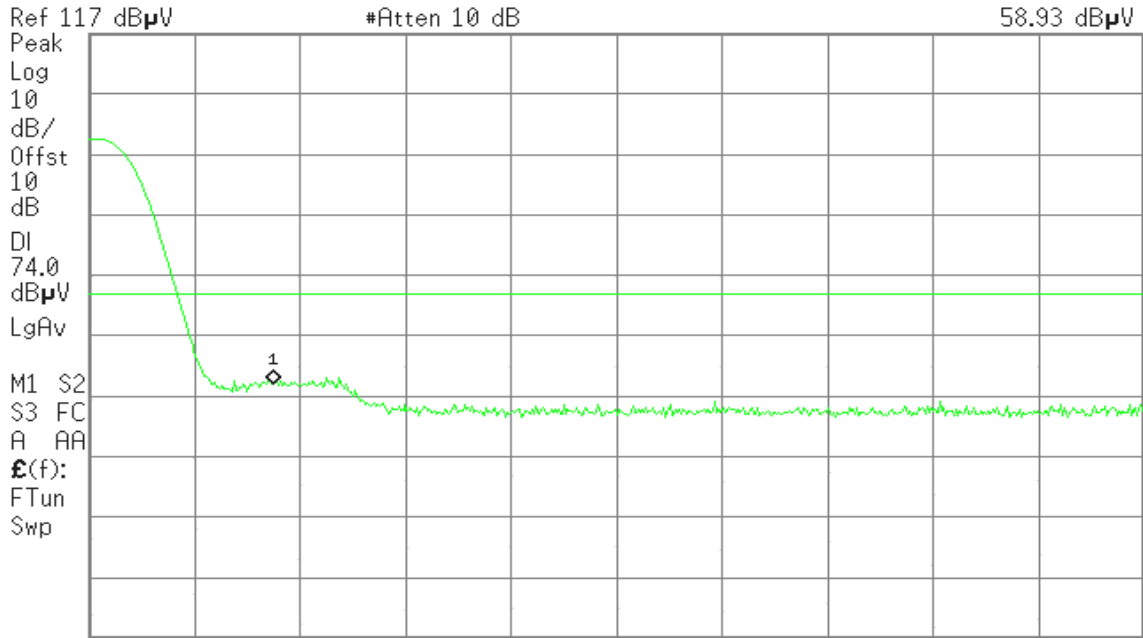

Start 2.480 00 GHz #Res BW 1 MHz #VBW 1 MHz Stop 2.500 00 GHz #Sweep 100 ms (601 pts)

Detector mode: Average

Polarity: Horizontal

Agilent

R T

Mkr1 2.484 00 GHz
48.55 dBμV

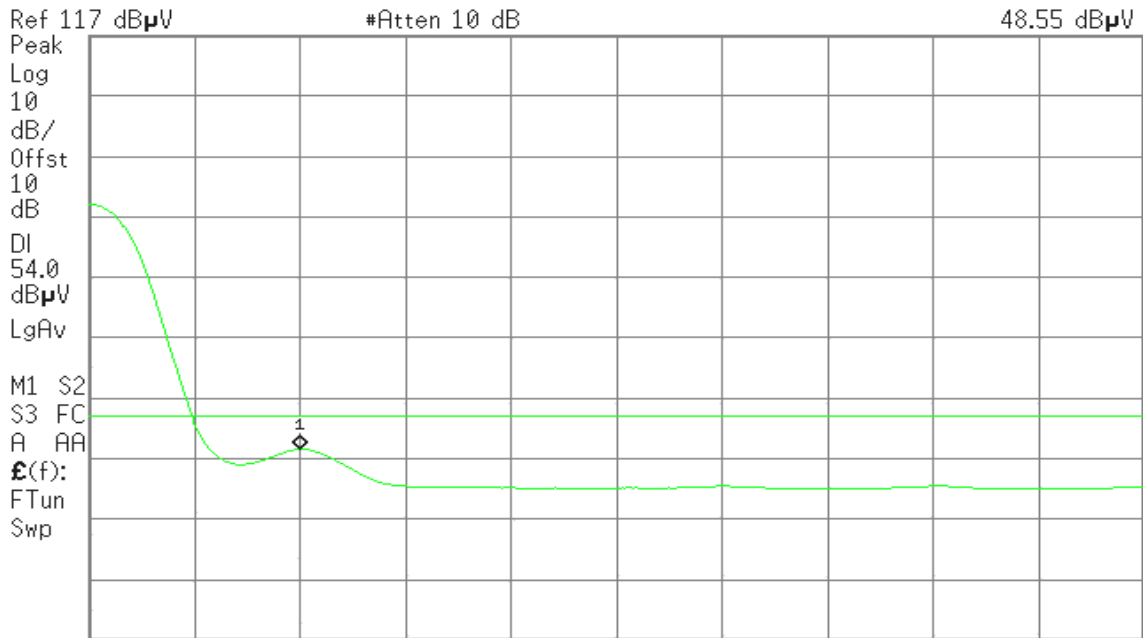

Start 2.480 00 GHz #Res BW 1 MHz #VBW 10 Hz Stop 2.500 00 GHz Sweep 1.56 s (601 pts)



For 8DPSK

Band Edges (CH Low)

Detector mode: Peak

Polarity: Vertical

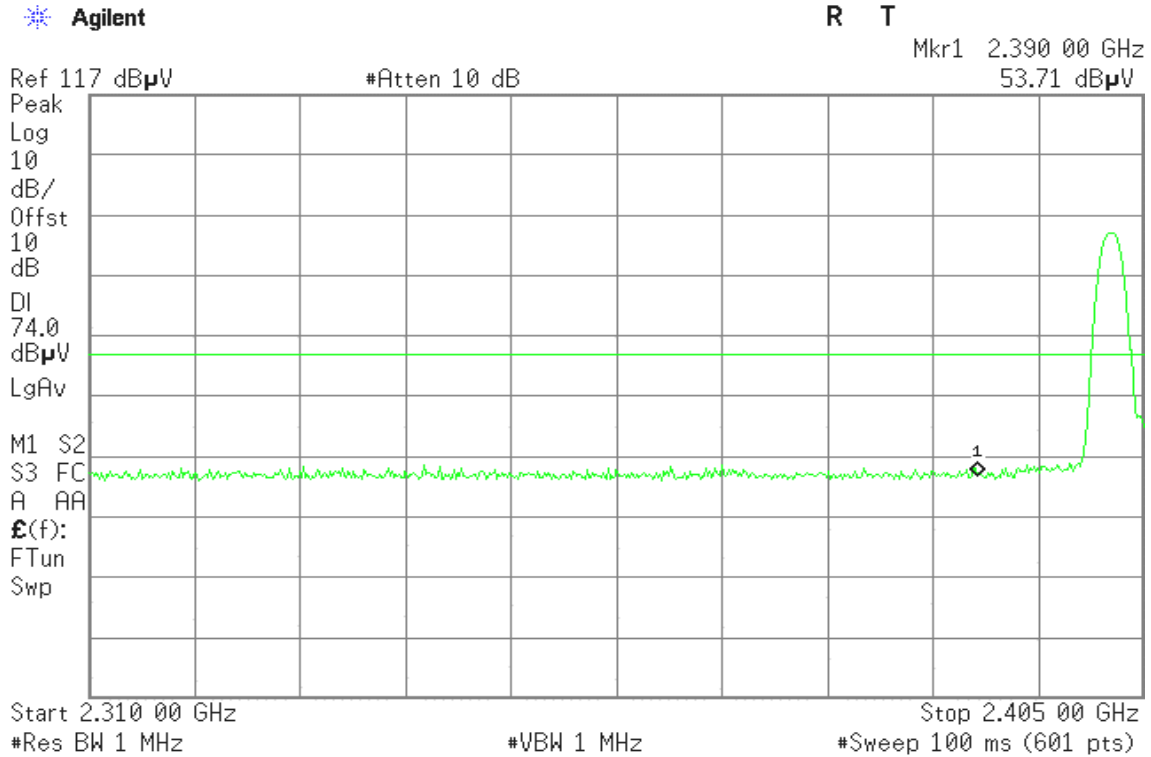

Detector mode: Average

Polarity: Vertical

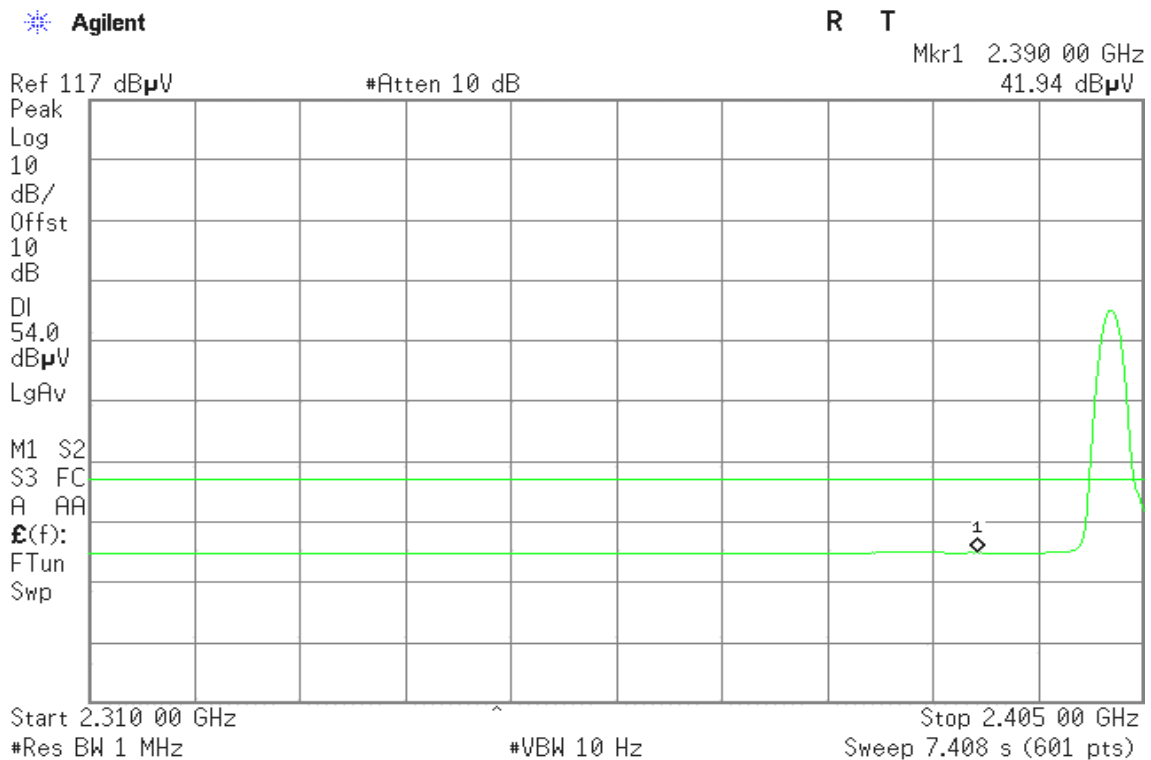



Detector mode: Peak

Polarity: Horizontal

Agilent

R T

Mkr1 2.390 00 GHz
54.71 dBμV

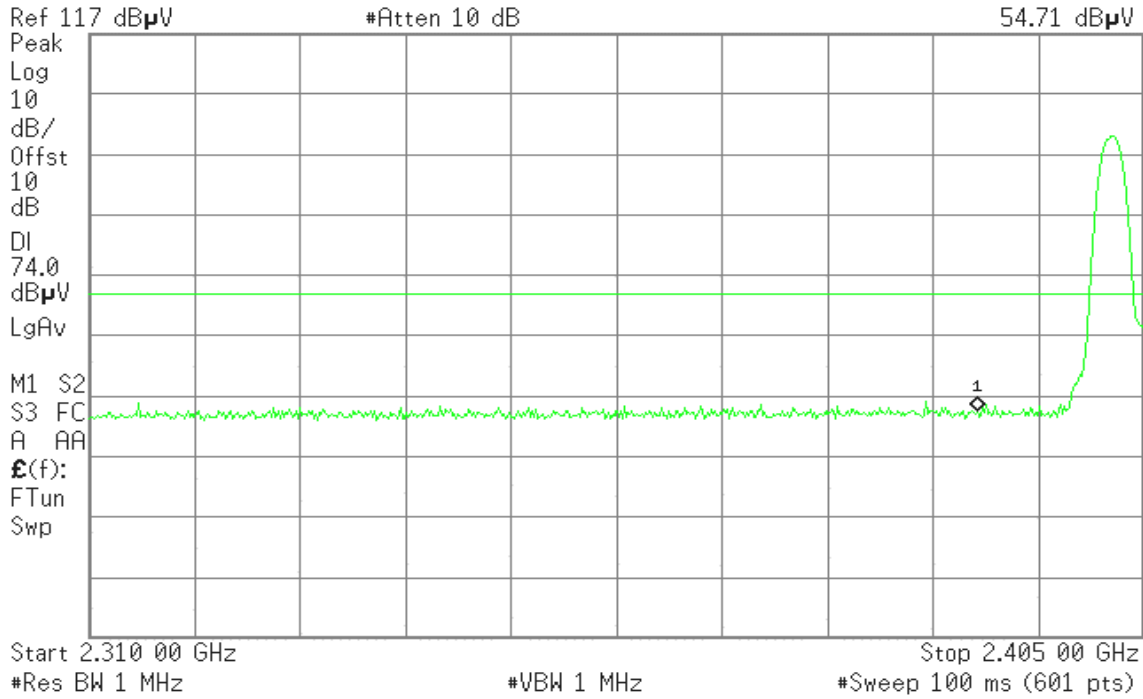

Detector mode: Average

Polarity: Horizontal

Agilent

R T

Mkr1 2.390 00 GHz
42.23 dBμV

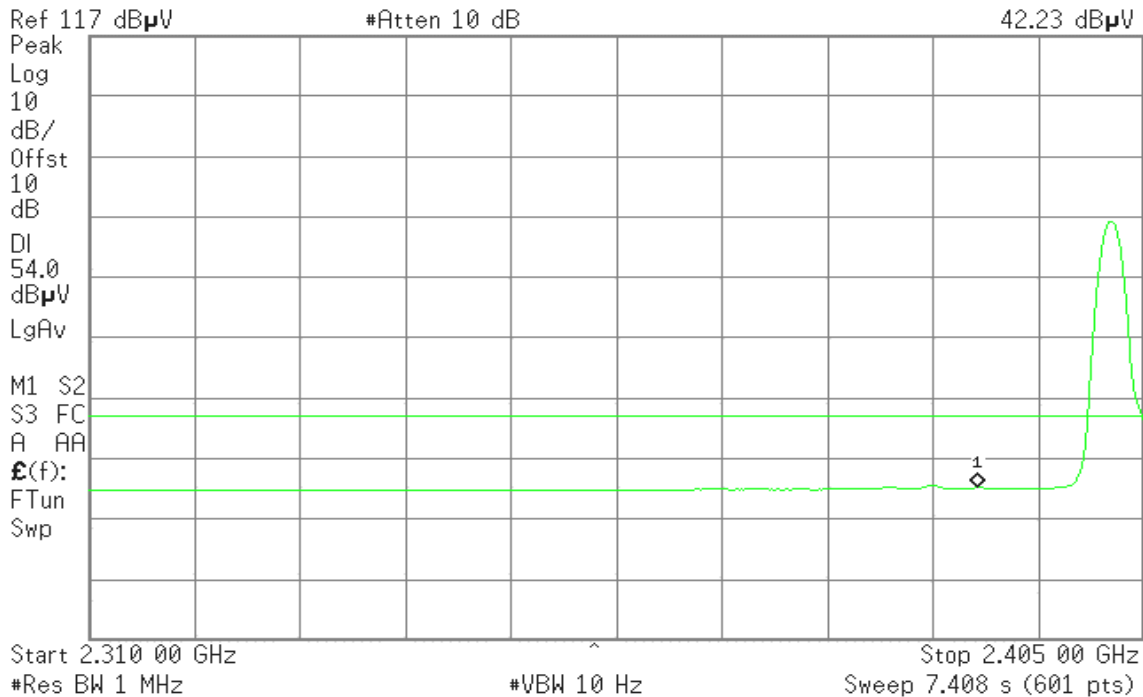



Band Edges (CH High)

Detector mode: Peak

Polarity: Vertical

Agilent

R T

Mkr1 2.483 50 GHz
61.91 dB μ V

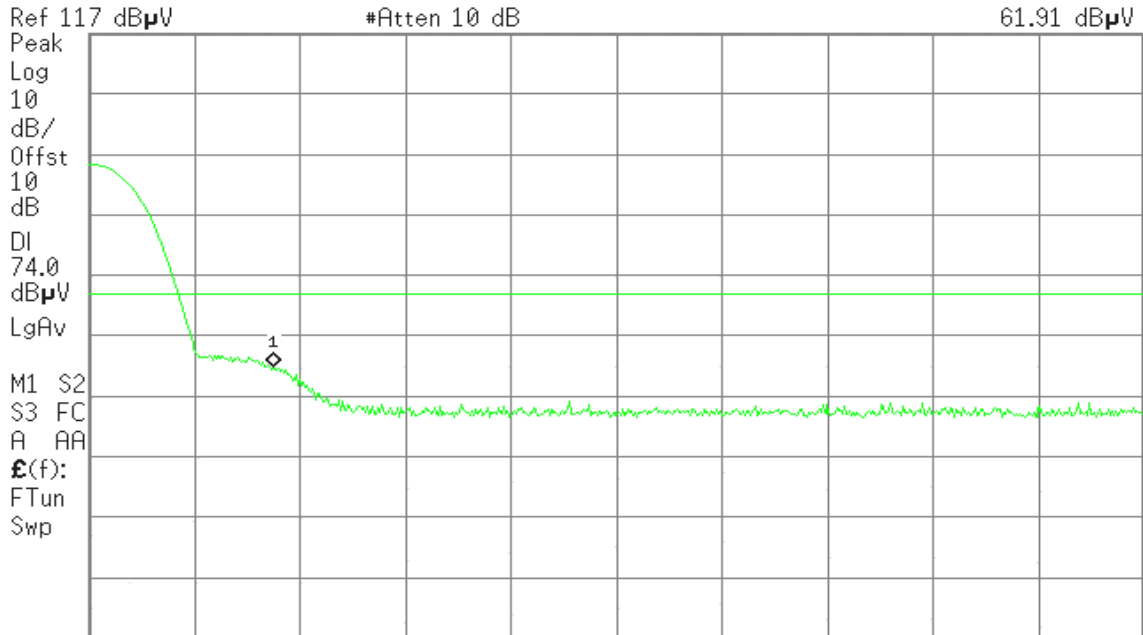

Detector mode: Average

Polarity: Vertical

Agilent

R T

Mkr1 2.483 50 GHz
47.73 dB μ V

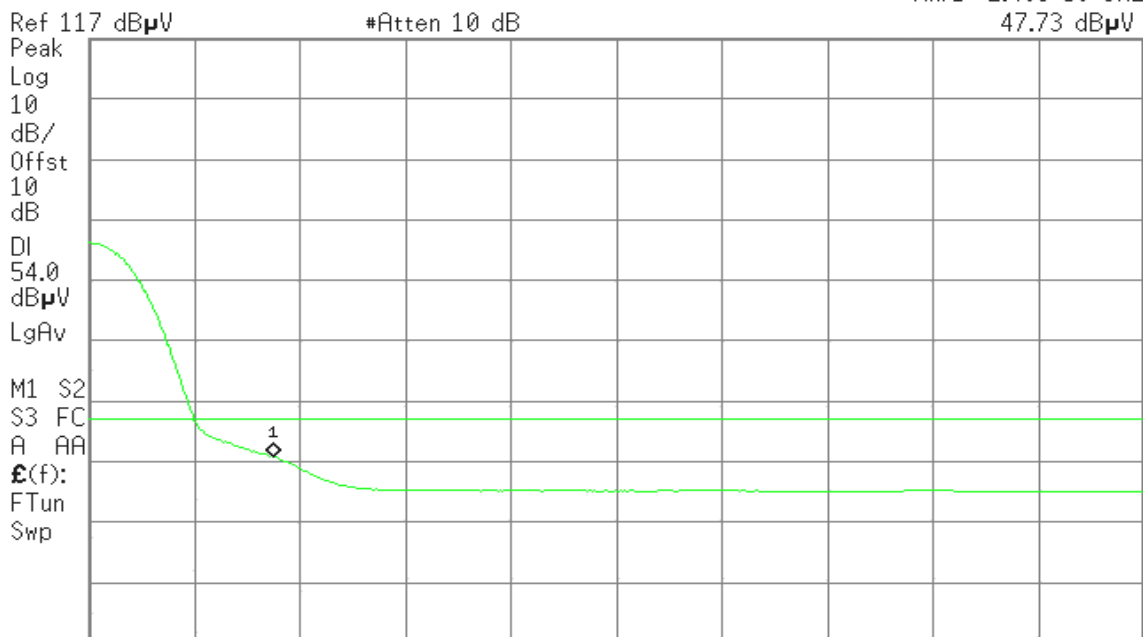



Detector mode: Peak

Polarity: Horizontal

Agilent

R T

Mkr1 2.483 50 GHz
62.92 dBμV

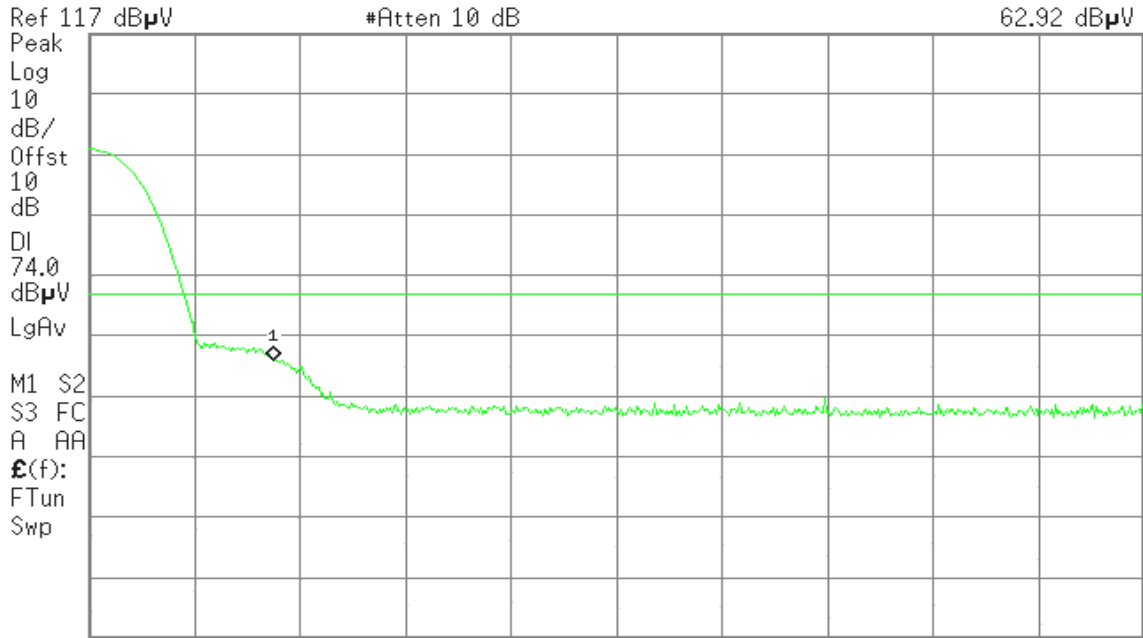

Start 2.480 00 GHz #Res BW 1 MHz #VBW 1 MHz Stop 2.500 00 GHz #Sweep 100 ms (601 pts)

Detector mode: Average

Polarity: Horizontal

Agilent

R T

Mkr1 2.483 50 GHz
49.08 dBμV

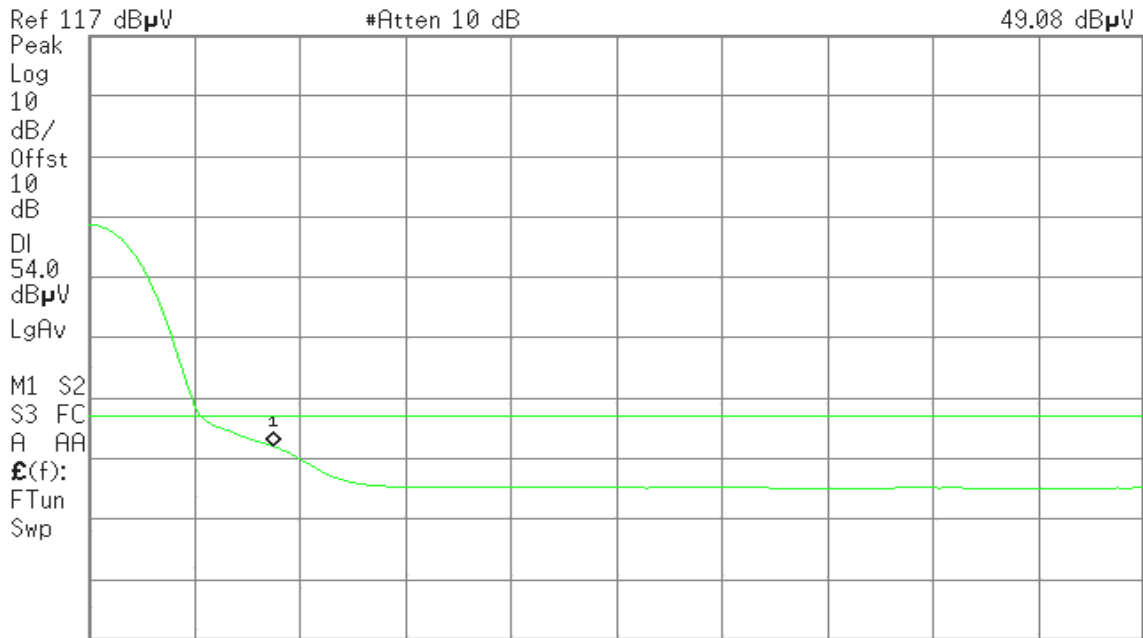

Start 2.480 00 GHz #Res BW 1 MHz #VBW 10 Hz Stop 2.500 00 GHz Sweep 1.56 s (601 pts)

7.4 PEAK POWER SPECTRAL DENSITY

LIMIT

1. According to §15.247(e), for digitally modulated systems, the power spectral density conducted from the intentional radiator to the antenna shall not be greater than 8 dBm in any 3 kHz band during any time interval of continuous transmission.
2. According to §15.247(f), the digital modulation operation of the hybrid system, with the frequency hopping turned off, shall comply with the power density requirements of paragraph (d) of this section.

Test Configuration

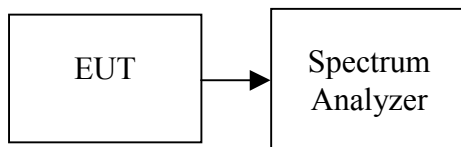

TEST PROCEDURE

1. Place the EUT on the table and set it in transmitting mode.
2. Remove the antenna from the EUT and then connect a low loss RF cable from the antenna port to the spectrum analyzer.
3. Set the spectrum analyzer as RBW = 3kHz, VBW = 10kHz, Span = 300kHz, Sweep=100s
4. Record the max. reading.
5. Repeat the above procedure until the measurements for all frequencies are completed.

TEST RESULTS

No non-compliance noted.



Test Data

For GFSK

Channel	Frequency (MHz)	PPSD (dBm)	Limit (dBm)	Result
Low	2402	-16.93	8.00	PASS
Mid	2441	-17.39		PASS
High	2480	-17.42		PASS

For 8DPSK

Channel	Frequency (MHz)	PPSD (dBm)	Limit (dBm)	Result
Low	2402	-19.88	8.00	PASS
Mid	2441	-20.31		PASS
High	2480	-20.51		PASS



Test Plot

For GFSK

PPSD (CH Low)

Agilent 10:49:42 Mar 10, 2008

R T
Mkr1 2.402 023 1 GHz
-16.93 dBm

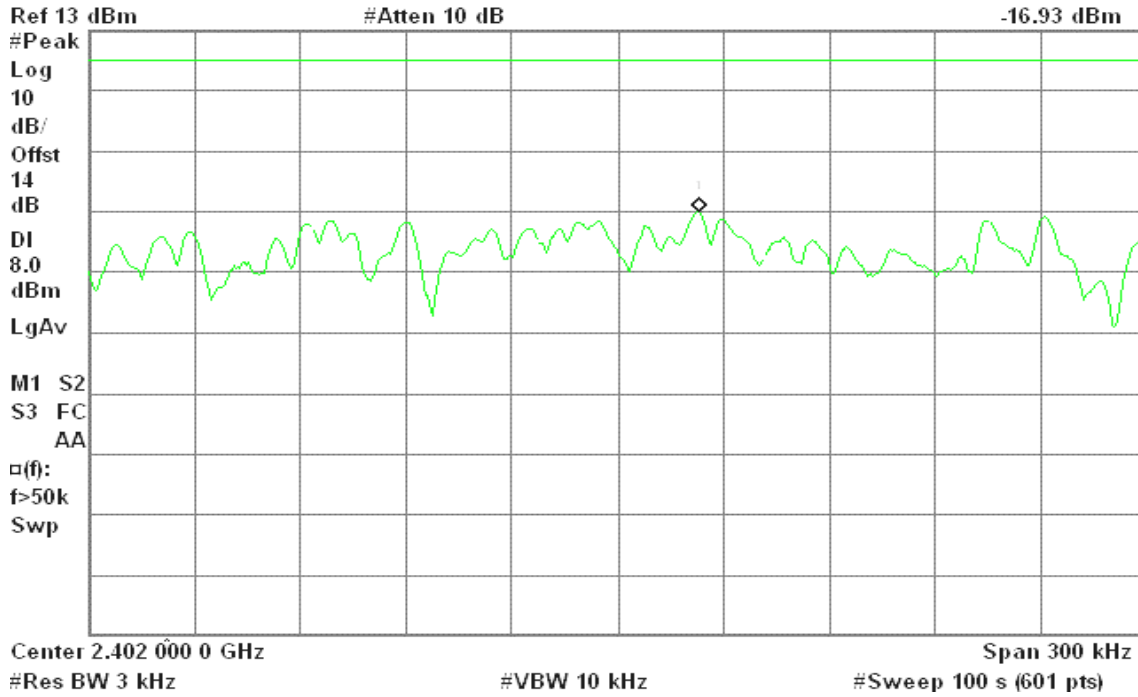

PPSD (CH Mid)

Agilent 10:47:31 Mar 10, 2008

R T
Mkr1 2.441 022 6 GHz
-17.39 dBm

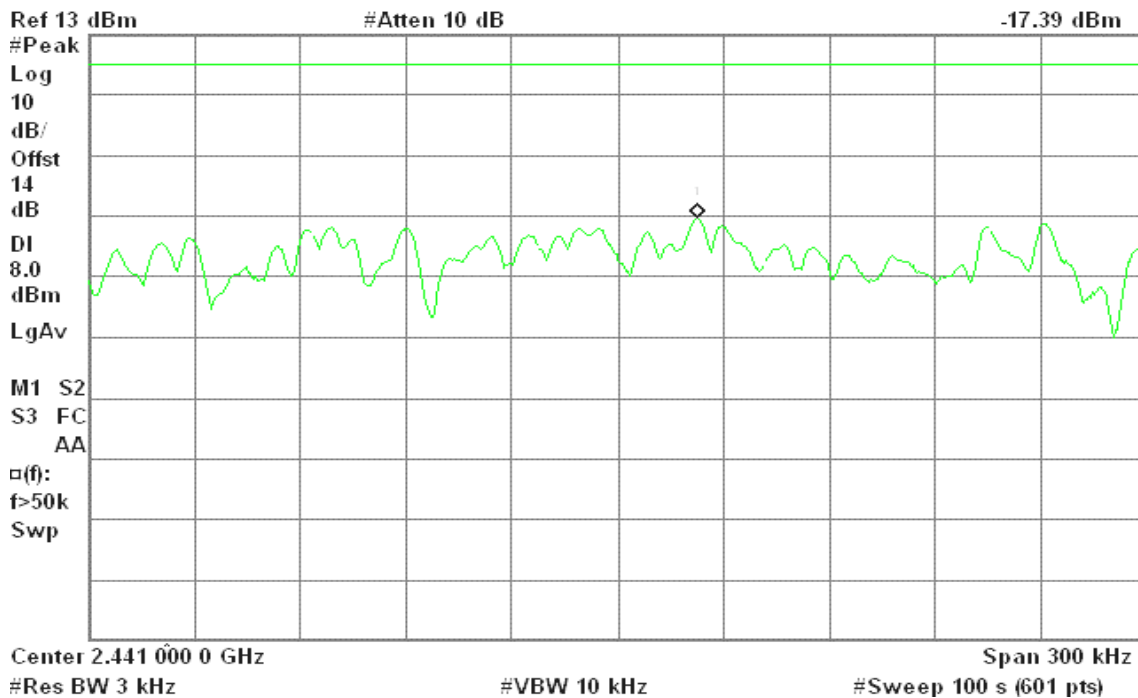



PPSD (CH High)

* Agilent 10:45:21 Mar 10, 2008

R T

Mkr1 2.480 022 6 GHz

-17.42 dBm

Ref 13 dBm

#Atten 10 dB

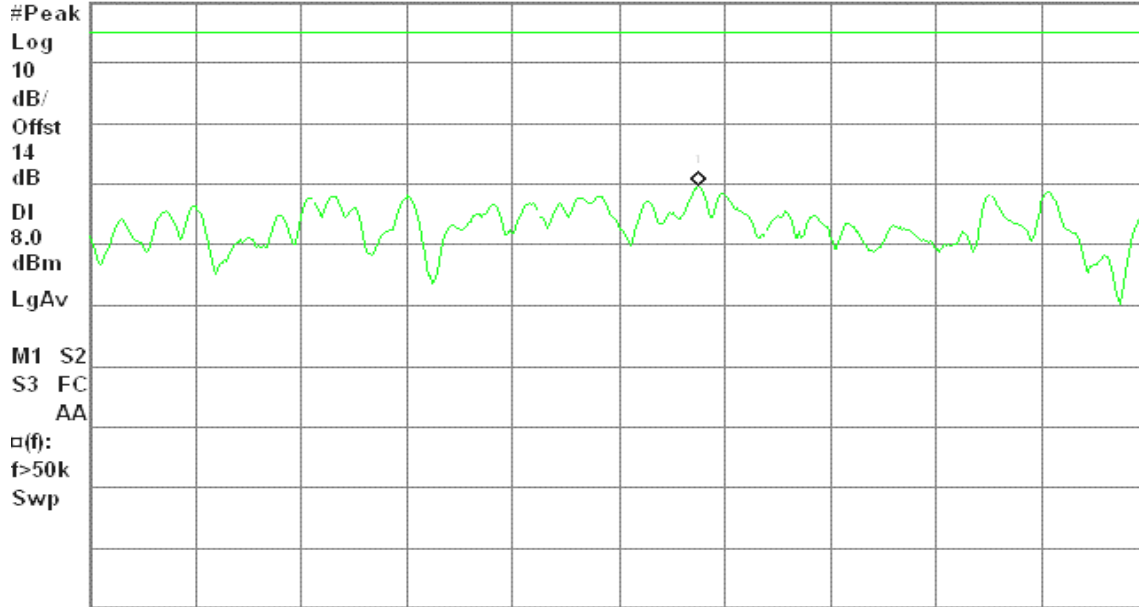

Center 2.480 000 0 GHz

Span 300 kHz

#Res BW 3 kHz

#VBW 10 kHz

#Sweep 100 s (601 pts)



For 8DPSK

PPSD (CH Low)

Agilent 12:52:34 Mar 10, 2008

R T

Mkr1 2.402 125 9 GHz
-19.88 dBm

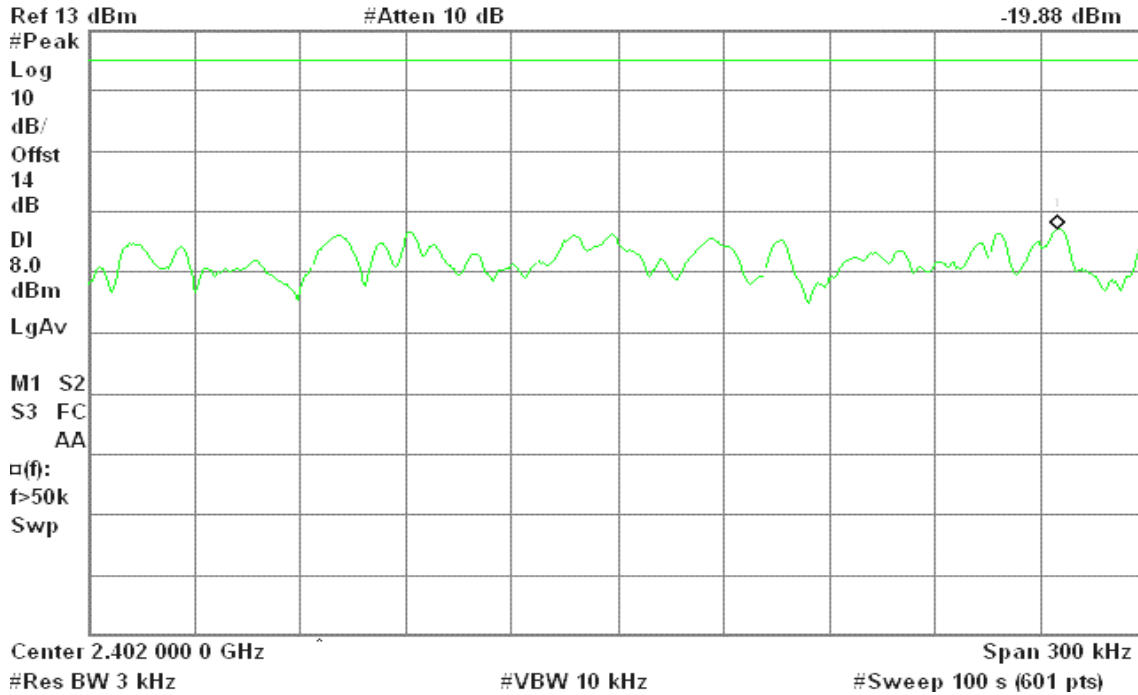

PPSD (CH Mid)

Agilent 12:44:39 Mar 10, 2008

R T

Mkr1 2.441 126 4 GHz
-20.31 dBm

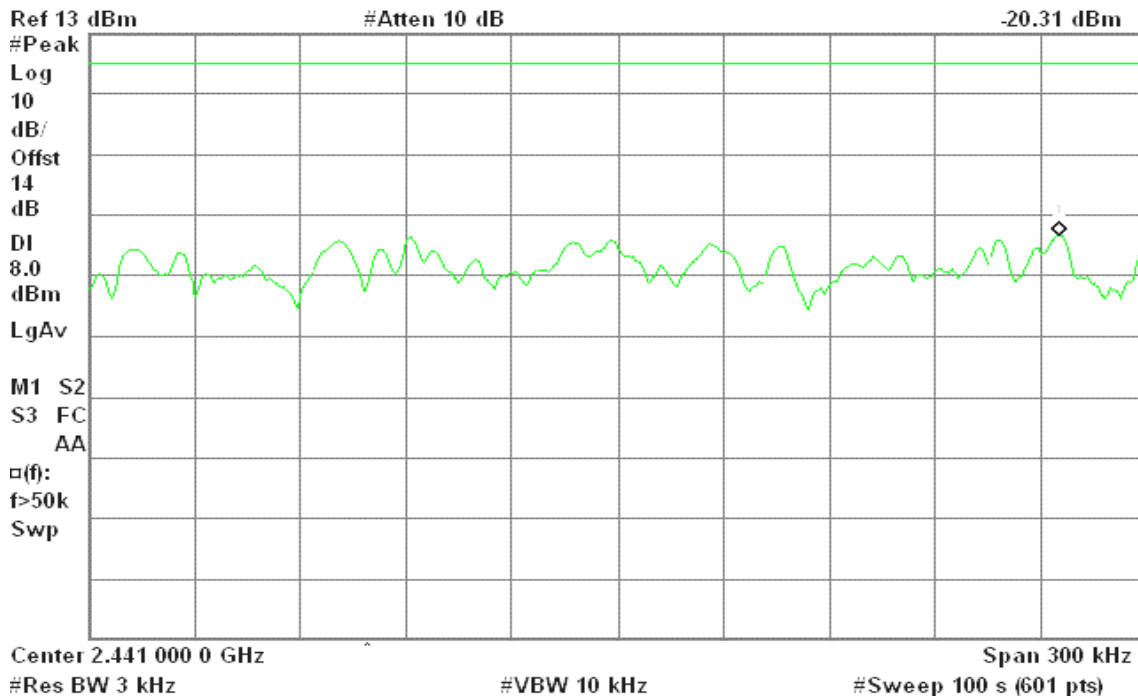



PPSD (CH High)

Agilent 12:42:05 Mar 10, 2008

R T

Mkr1 2.480 126 1 GHz

-20.51 dBm

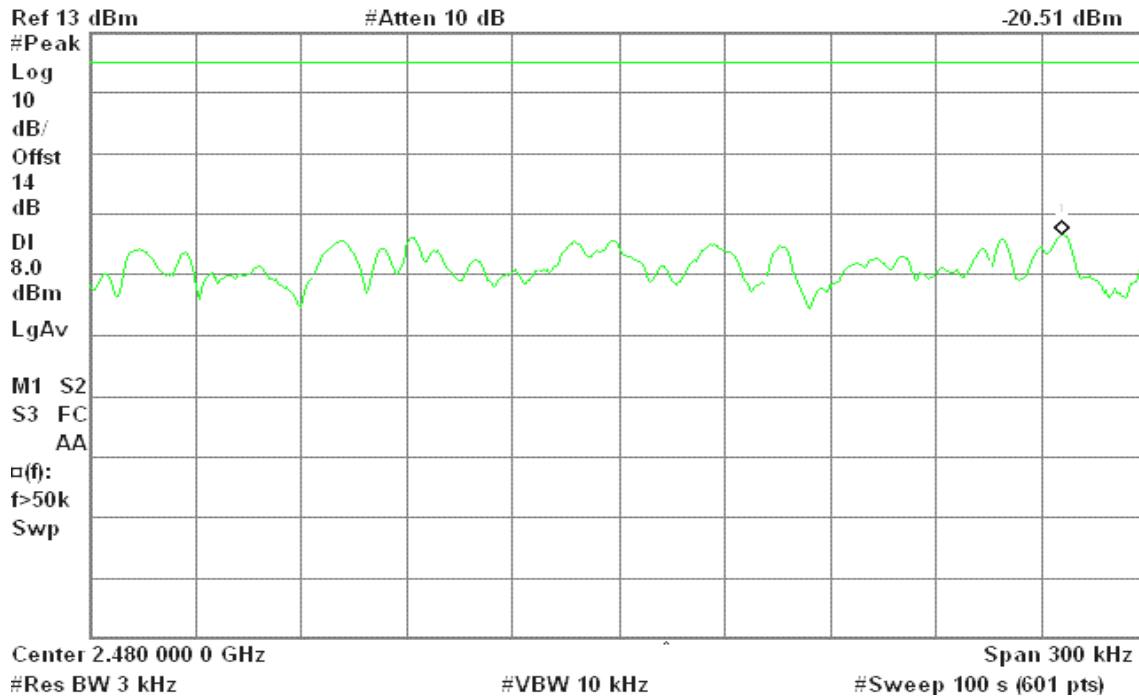



7.5 FREQUENCY SEPARATION

LIMIT

According to §15.247(a)(1), Frequency hopping systems shall have hopping channel carrier frequencies separated by a minimum of 25 kHz or the 20 dB bandwidth of the hopping channel, whichever is greater. Alternatively, frequency hopping systems operating in the 2400-2483.5 MHz band may have hopping channel carrier frequencies that are separated by 25 kHz or two-thirds of the 20 dB bandwidth of the hopping channel, whichever is greater, provided the systems operate with an output power no greater than 125 mW.

Test Configuration

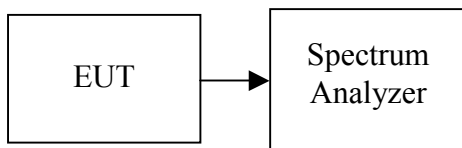

TEST PROCEDURE

1. Place the EUT on the table and set it in transmitting mode.
2. Remove the antenna from the EUT and then connect a low loss RF cable from the antenna port to the spectrum analyzer.
3. Set center frequency of spectrum analyzer = middle of hopping channel.
4. Set the spectrum analyzer as RBW = 30kHz, VBW = 100kHz, Span = 3MHz, Sweep = auto.
5. Max hold, mark 3 peaks of hopping channel and record the 3 peaks frequency.

TEST RESULTS

No non-compliance noted

Test Data

For GFSK

Channel Separation (MHz)	two-thirds of the 20 dB bandwidth (kHz)	Channel Separation Limit	Result
0.125	618	> two-thirds of the 20 dB bandwidth	Pass

For 8DPSK

Channel Separation (MHz)	two-thirds of the 20 dB bandwidth (kHz)	Channel Separation Limit	Result
0.125	855	> two-thirds of the 20 dB bandwidth	Pass



Test Plot

For GFSK

Measurement of Channel Separation

Agilent 12:19:59 Mar 10, 2008

R T

Mkr3 2.441 980 GHz
-7.73 dBm

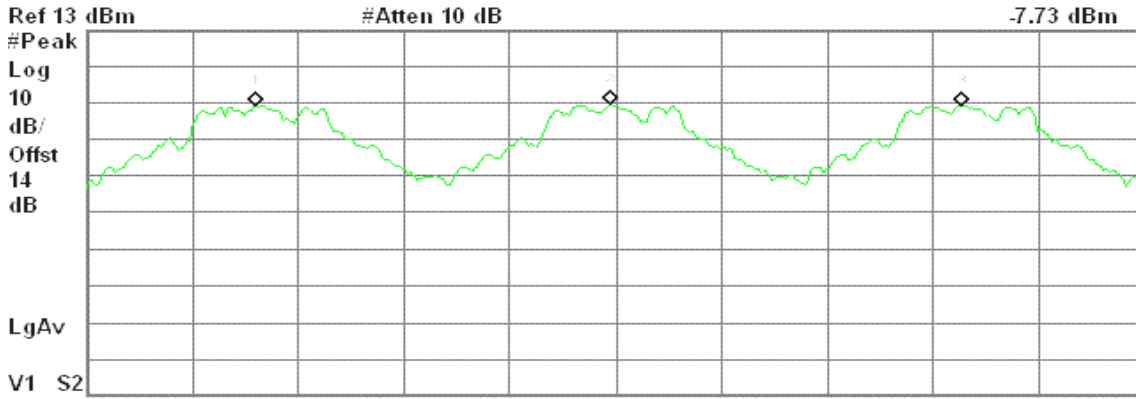

Center 2.441 000 GHz Span 3 MHz
#Res BW 30 kHz #VBW 100 kHz Sweep 3.2 ms (601 pts)

Marker	Trace	Type	X Axis	Amplitude
1	(1)	Freq	2.439 980 GHz	-7.71 dBm
2	(1)	Freq	2.440 980 GHz	-7.53 dBm
3	(1)	Freq	2.441 980 GHz	-7.73 dBm

Measurement of 20dB Bandwidth

Agilent 10:26:50 Mar 10, 2008

R T

Δ Mkr2 927 kHz
-0.03 dB

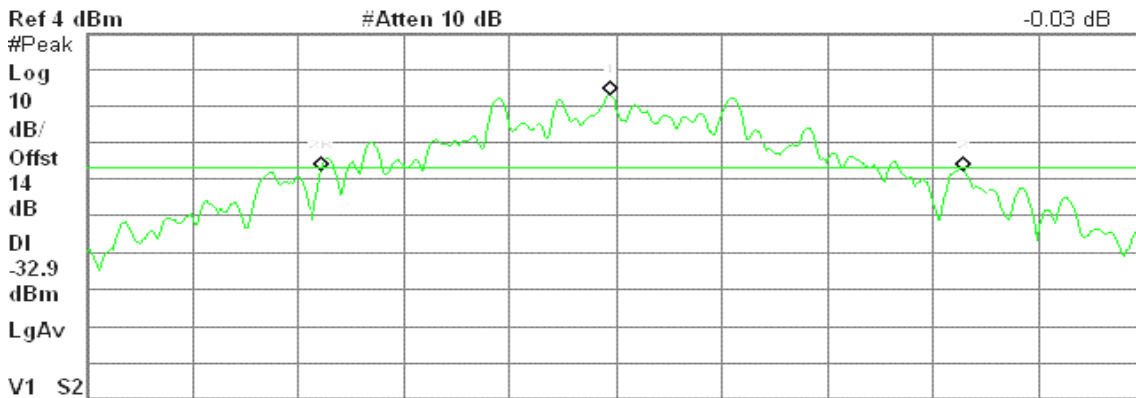

Center 2.480 000 GHz Span 1.5 MHz
#Res BW 10 kHz #VBW 30 kHz Sweep 14.36 ms (601 pts)

Marker	Trace	Type	X Axis	Amplitude
1	(1)	Freq	2.479 990 GHz	-12.94 dBm
2R	(1)	Freq	2.479 569 GHz	-33.51 dBm
2Δ	(1)	Freq	927 kHz	-0.03 dB



For 8DPSK

Measurement of Channel Separation

Agilent 12:59:02 Mar 10, 2008

R T

Mkr3 2.442 150 GHz

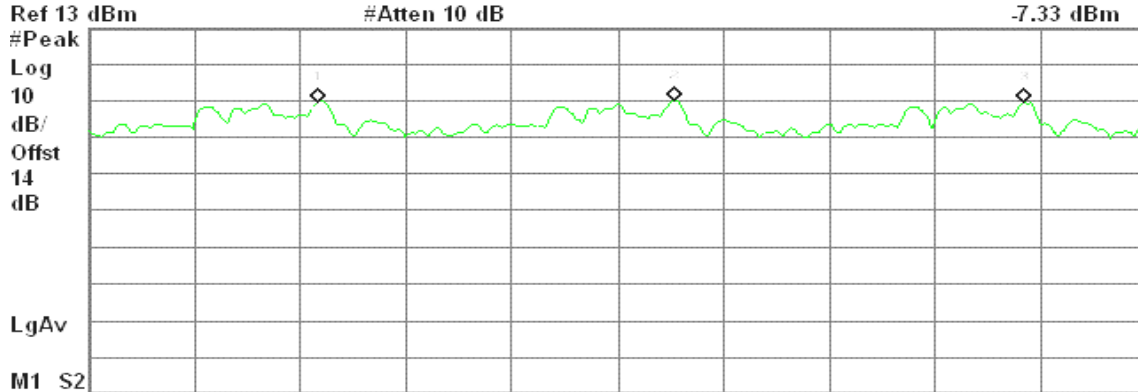

Center 2.441 000 GHz Span 3 MHz

#Res BW 30 kHz #VBW 100 kHz Sweep 3.2 ms (601 pts)

Marker	Trace	Type	X Axis	Amplitude
1	(1)	Freq	2.440 150 GHz	-7.34 dBm
2	(1)	Freq	2.441 160 GHz	-6.80 dBm
3	(1)	Freq	2.442 150 GHz	-7.33 dBm

Measurement of 20dB Bandwidth

Agilent 12:22:23 Mar 10, 2008

R T

Δ Mkr2 1.283 MHz

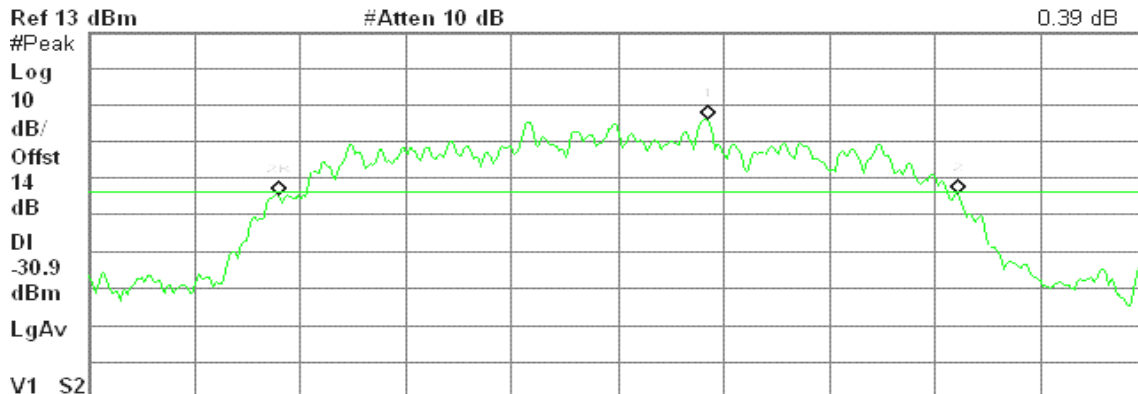

Center 2.402 000 GHz Span 2 MHz

#Res BW 10 kHz #VBW 30 kHz Sweep 19.12 ms (601 pts)

Marker	Trace	Type	X Axis	Amplitude
1	(1)	Freq	2.402 170 GHz	-10.91 dBm
2R	(1)	Freq	2.401 360 GHz	-31.39 dBm
2Δ	(1)	Freq	1.283 MHz	0.39 dB

7.6 NUMBER OF HOPPING FREQUENCY

LIMIT

According to §15.247(a)(1)(iii), Frequency hopping systems operating in the 2400MHz-2483.5 MHz bands shall use at least 15 hopping frequencies.

Test Configuration

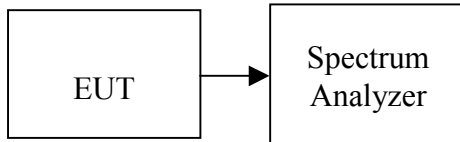

TEST PROCEDURE

1. Place the EUT on the table and set it in transmitting mode.
2. Remove the antenna from the EUT and then connect a low loss RF cable from the antenna port to the spectrum analyzer.
3. Set spectrum analyzer Start=2400MHz, Stop = 2441.5MHz, Sweep = auto and Start=2441.5MHz, Stop = 2483.5MHz, Sweep = auto.
4. Set the spectrum analyzer as RBW, VBW=510kHz.
5. Max hold, view and count how many channel in the band.

TEST RESULTS

No non-compliance noted

Test Data

For GFSK / 8DPSK

Result (No. of CH)	Limit (No. of CH)	Result
79	>15	PASS



Test Plot

For GFSK

Channel Number

2.4 GHz – 2.4415 GHz

Agilent 10:41:41 Mar 10, 2008

R T

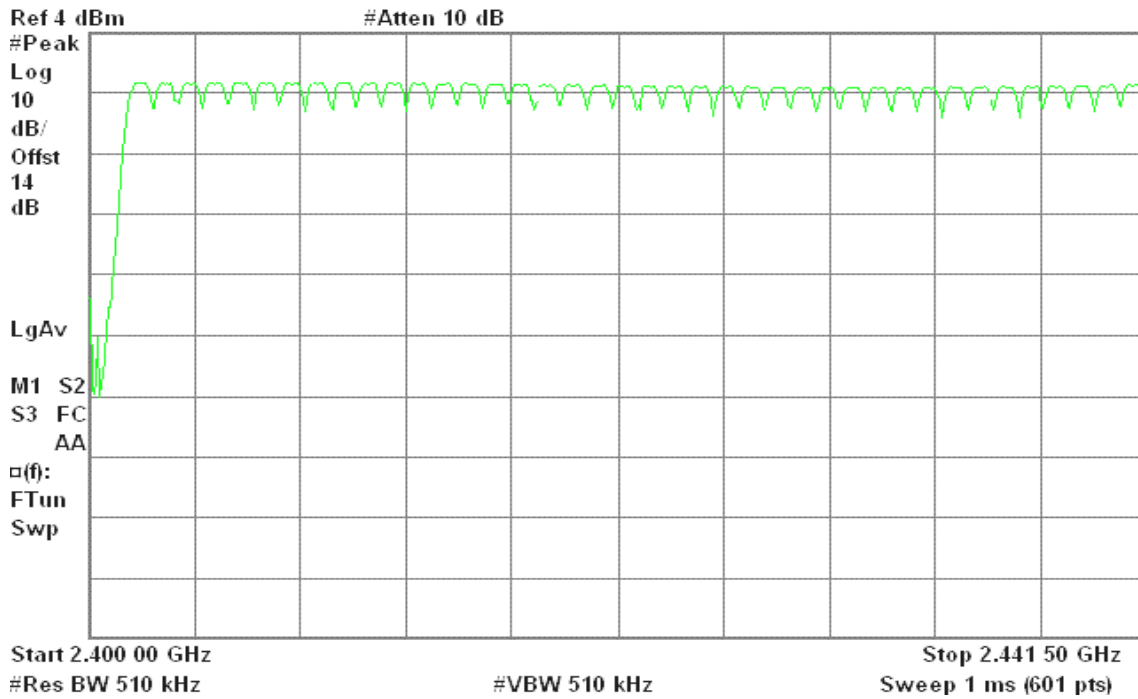

2.4415 GHz – 2.4835 GHz

Agilent 10:42:14 Mar 10, 2008

R T

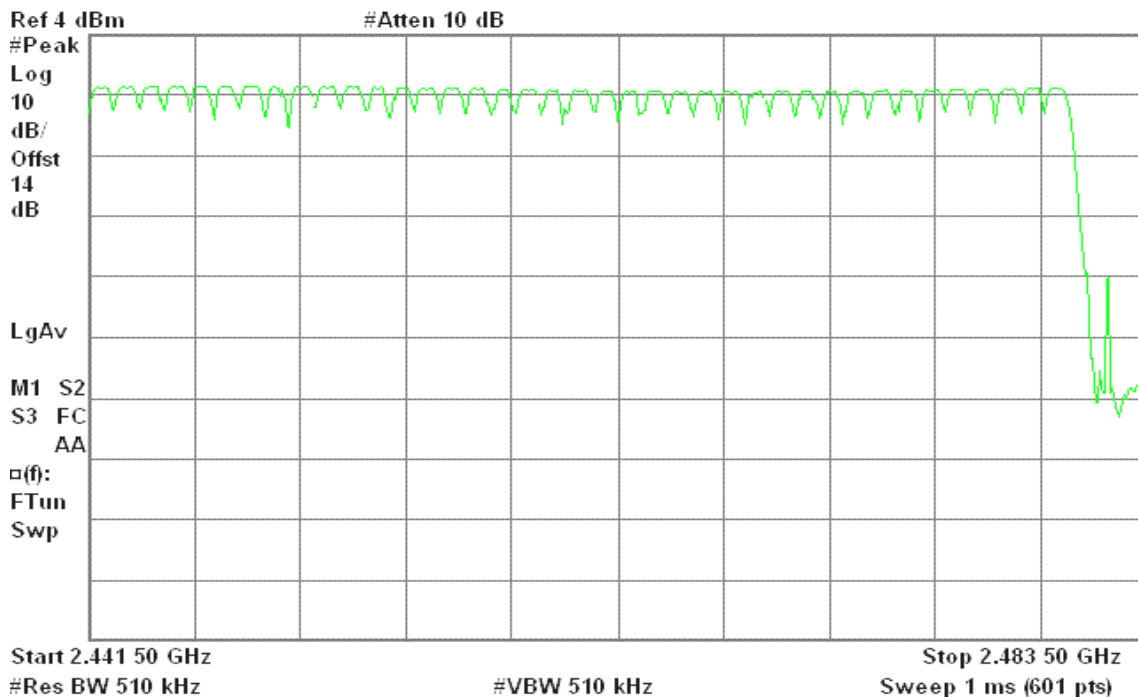



For 8DPSK

Channel Number

2.4 GHz – 2.4415 GHz

* Agilent 13:02:20 Mar 10, 2008

R T

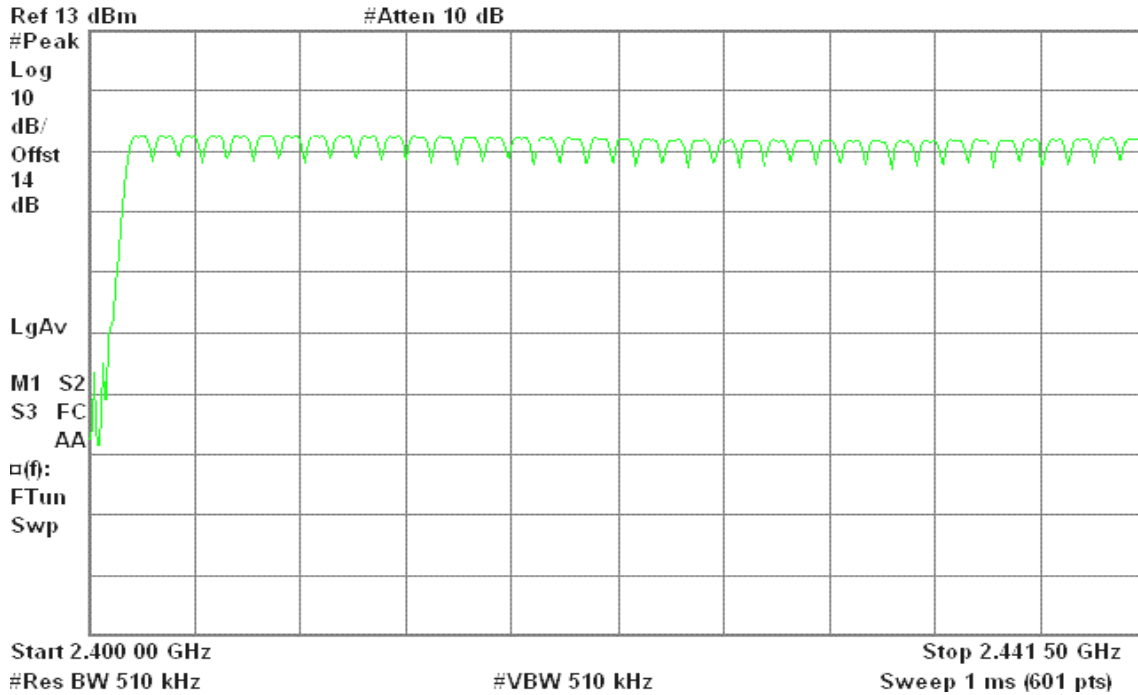

2.4415 GHz – 2.4835 GHz

* Agilent 13:03:06 Mar 10, 2008

R T

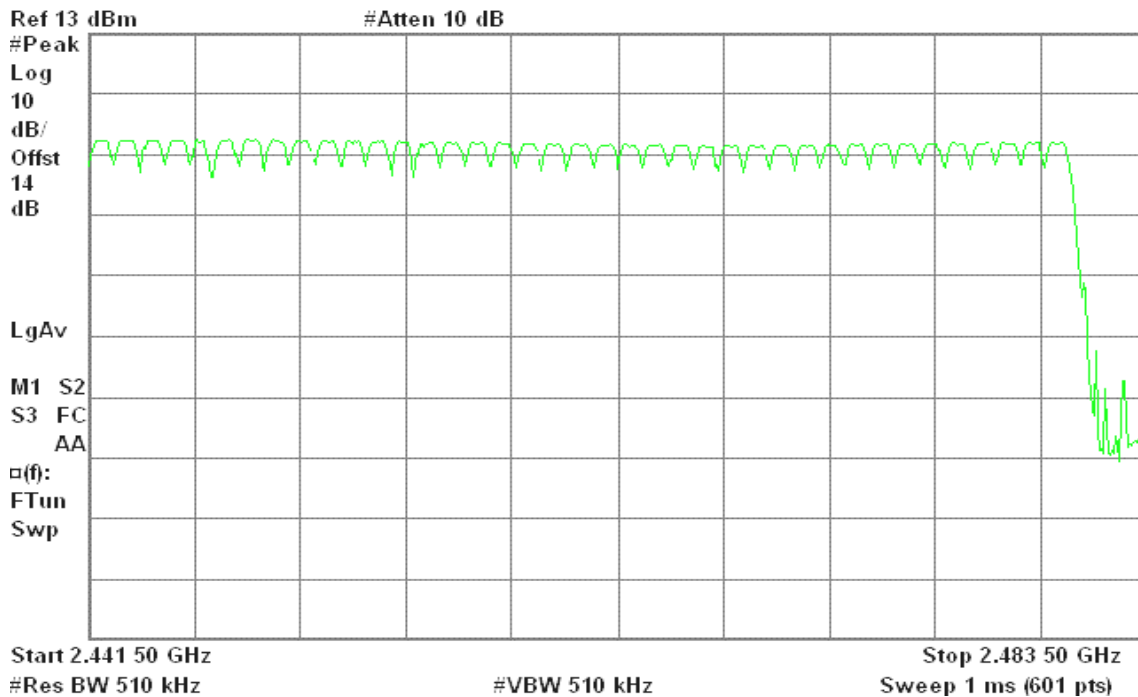

7.7 TIME OF OCCUPANCY (DWELL TIME)

LIMIT

According to §15.247(a)(1)(iii), Frequency hopping systems operating in the 2400MHz-2483.5 MHz bands. The average time of occupancy on any channels shall not greater than 0.4 s within a period 0.4 s multiplied by the number of hopping channels employed.

Test Configuration

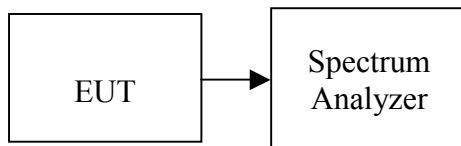

TEST PROCEDURE

1. Place the EUT on the table and set it in transmitting mode.
2. Remove the antenna from the EUT and then connect a low loss RF cable from the antenna port to the spectrum analyzer.
3. Set center frequency of spectrum analyzer = operating frequency.
4. Set the spectrum analyzer as RBW, VBW=1MHz, Span = 0Hz, Sweep = auto.
5. Repeat above procedures until all frequency measured were complete.



TEST RESULTS

No non-compliance noted.

Test Data

For GFSK

DH 1

CH Low: $0.3500 * (1600/2)/79 * 31.60 = 112.000$ (ms)

CH Mid: $0.3667 * (1600/2)/79 * 31.60 = 117.344$ (ms)

CH High: $0.3500 * (1600/2)/79 * 31.60 = 112.000$ (ms)

CH	Pulse Time (ms)	Total of Dwell (ms)	Period Time (s)	Limit (ms)	Result
Low	0.3500	112.000	31.60	400.00	PASS
Mid	0.3667	117.344	31.60		PASS
High	0.3500	112.000	31.60		PASS

DH 3

CH Low: $1.633 * (1600/4)/79 * 31.60 = 261.280$ (ms)

CH Mid: $1.617 * (1600/4)/79 * 31.60 = 258.720$ (ms)

CH High: $1.600 * (1600/4)/79 * 31.60 = 256.000$ (ms)

CH	Pulse Time (ms)	Total of Dwell (ms)	Period Time (s)	Limit (ms)	Result
Low	1.633	261.280	31.60	400.00	PASS
Mid	1.617	258.720	31.60		PASS
High	1.600	256.000	31.60		PASS

DH 5

CH Low: $2.867 * (1600/6)/79 * 31.60 = 305.813$ (ms)

CH Mid: $2.867 * (1600/6)/79 * 31.60 = 305.813$ (ms)

CH High: $2.883 * (1600/6)/79 * 31.60 = 307.520$ (ms)

CH	Pulse Time (ms)	Total of Dwell (ms)	Period Time (s)	Limit (ms)	Result
Low	2.867	305.813	31.60	400.00	PASS
Mid	2.867	305.813	31.60		PASS
High	2.883	307.520	31.60		PASS



For 8DPSK

DH 1

CH Low: $0.3833 * (1600/2)/79 * 31.60 = 122.656$ (ms)

CH Mid: $0.3833 * (1600/2)/79 * 31.60 = 122.656$ (ms)

CH High: $0.3500 * (1600/2)/79 * 31.60 = 112.000$ (ms)

CH	Pulse Time (ms)	Total of Dwell (ms)	Period Time (s)	Limit (ms)	Result
Low	0.3833	122.656	31.60	400.00	PASS
Mid	0.3833	122.656	31.60		PASS
High	0.3500	112.000	31.60		PASS

DH 3

CH Low: $1.617 * (1600/4)/79 * 31.60 = 258.720$ (ms)

CH Mid: $1.617 * (1600/4)/79 * 31.60 = 258.720$ (ms)

CH High: $1.617 * (1600/4)/79 * 31.60 = 258.720$ (ms)

CH	Pulse Time (ms)	Total of Dwell (ms)	Period Time (s)	Limit (ms)	Result
Low	1.617	258.720	31.60	400.00	PASS
Mid	1.617	258.720	31.60		PASS
High	1.617	258.720	31.60		PASS

DH 5

CH Low: $2.850 * (1600/6)/79 * 31.6 = 304.000$ (ms)

CH Mid: $2.850 * (1600/6)/79 * 31.6 = 304.000$ (ms)

CH High: $2.883 * (1600/6)/79 * 31.6 = 307.520$ (ms)

CH	Pulse Time (ms)	Total of Dwell (ms)	Period Time (s)	Limit (ms)	Result
Low	2.850	304.000	31.60	400.00	PASS
Mid	2.850	304.000	31.60		PASS
High	2.883	307.520	31.60		PASS



Test Plot
For GFSK
DH 1
(CH Low)

Agilent 10:31:49 Mar 10, 2008

R T

Delta Mkr2 383.3 us
-0.16 dB

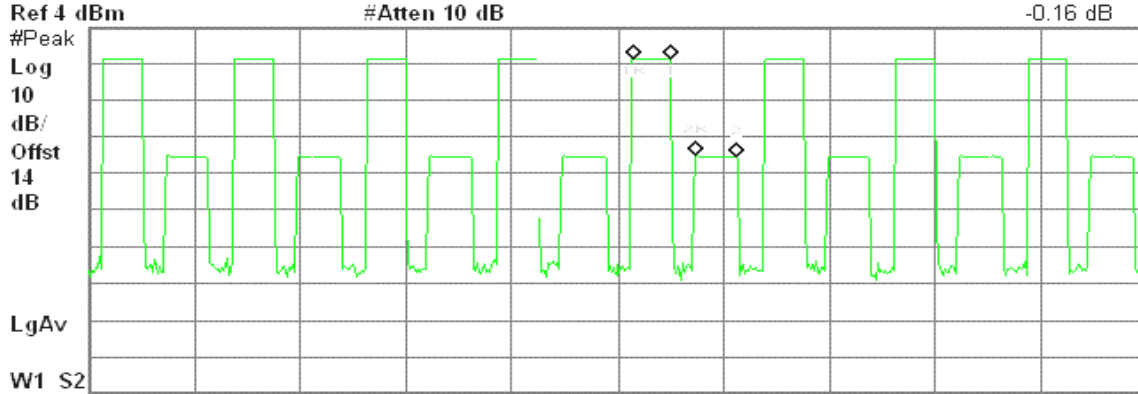

Table with 5 columns: Marker, Trace, Type, X Axis, Amplitude. Contains 4 rows of marker data.

(CH Mid)

Agilent 10:32:53 Mar 10, 2008

R T

Delta Mkr2 383.3 us
-0.21 dB

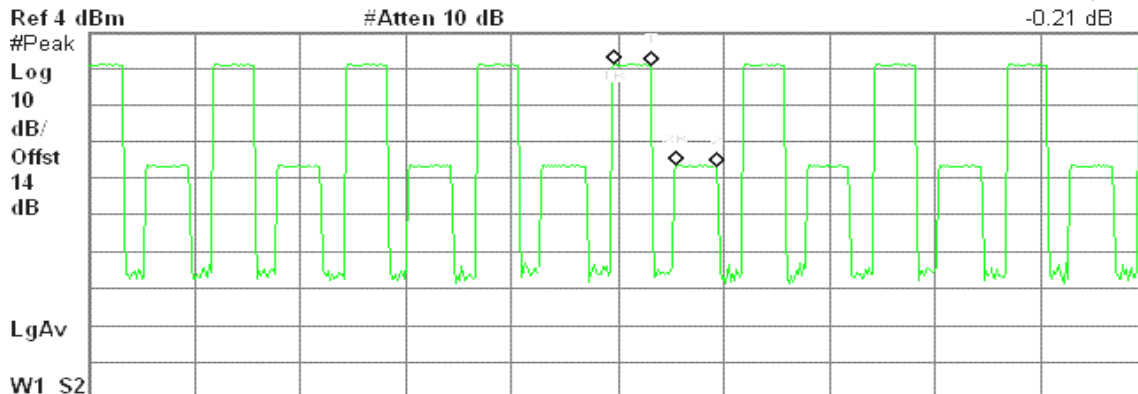

Table with 5 columns: Marker, Trace, Type, X Axis, Amplitude. Contains 4 rows of marker data.



(CH High)

Agilent 10:33:53 Mar 10, 2008

R T

Δ Mkr1 350 μs
-0.05 dB

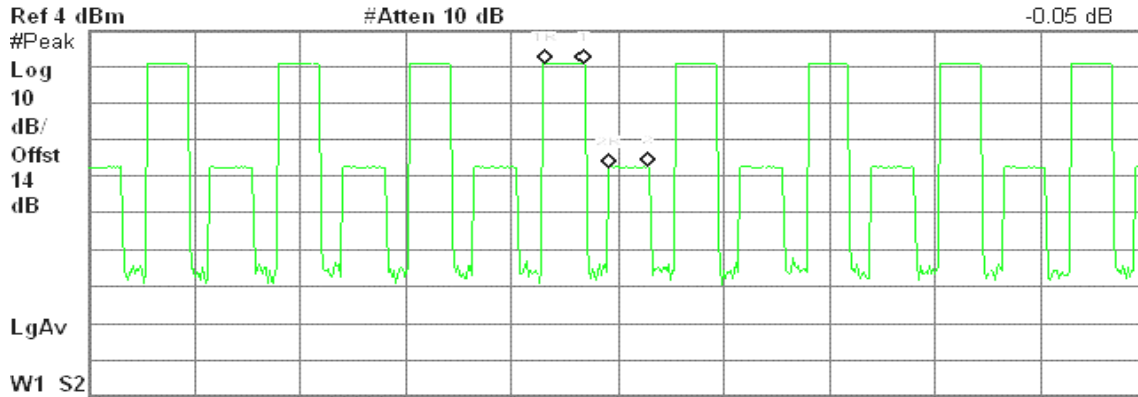

Center 2.480 000 GHz Span 0 Hz
Res BW 1 MHz #VBW 1 MHz Sweep 10 ms (601 pts)

Marker	Trace	Type	X Axis	Amplitude
1R	(1)	Time	4.317 ms	-4.99 dBm
1Δ	(1)	Time	350 μs	-0.05 dB
2R	(1)	Time	4.9 ms	-33.75 dBm
2Δ	(1)	Time	383.3 μs	0.33 dB

DH 3

(CH Low)

Agilent 10:36:19 Mar 10, 2008

R T

Δ Mkr2 1.633 ms
-1.06 dB

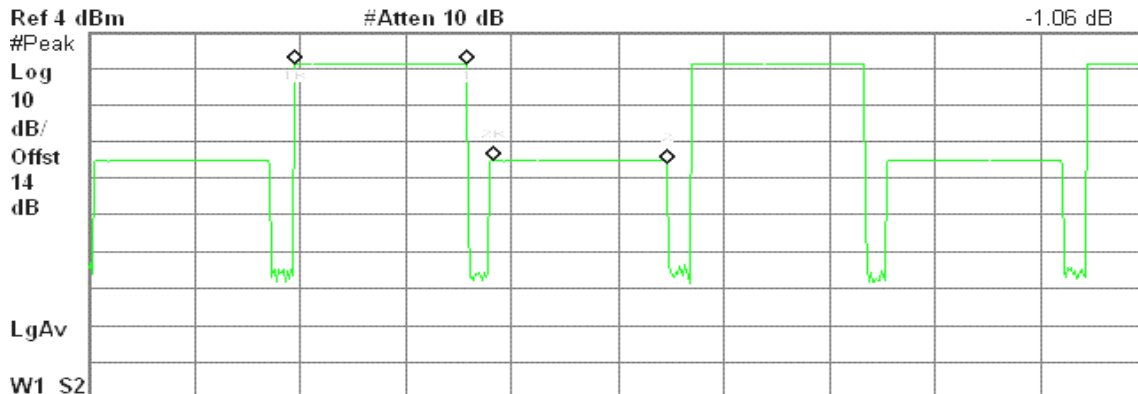

Center 2.402 000 GHz Span 0 Hz
Res BW 1 MHz #VBW 1 MHz Sweep 10 ms (601 pts)

Marker	Trace	Type	X Axis	Amplitude
1R	(1)	Time	1.95 ms	-4.68 dBm
1Δ	(1)	Time	1.633 ms	0.23 dB
2R	(1)	Time	3.833 ms	-30.99 dBm
2Δ	(1)	Time	1.633 ms	-1.06 dB



(CH Mid)

Agilent 10:35:38 Mar 10, 2008

R T

Δ Mkr1 1.617 ms
0.00 dB

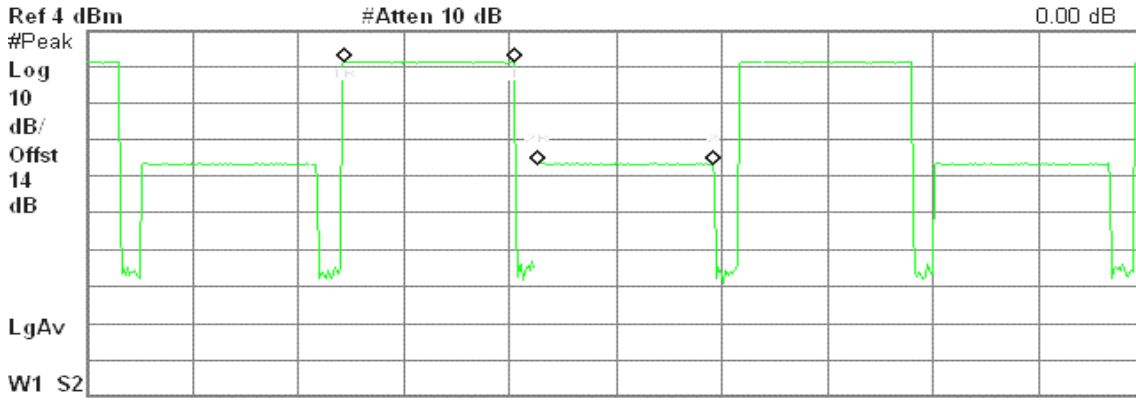

Marker	Trace	Type	X Axis	Amplitude
1R	(1)	Time	2.433 ms	-4.79 dBm
1Δ	(1)	Time	1.617 ms	0.00 dB
2R	(1)	Time	4.267 ms	-32.77 dBm
2Δ	(1)	Time	1.65 ms	0.17 dB

(CH High)

Agilent 10:34:57 Mar 10, 2008

R T

Δ Mkr2 1.617 ms
-0.02 dB

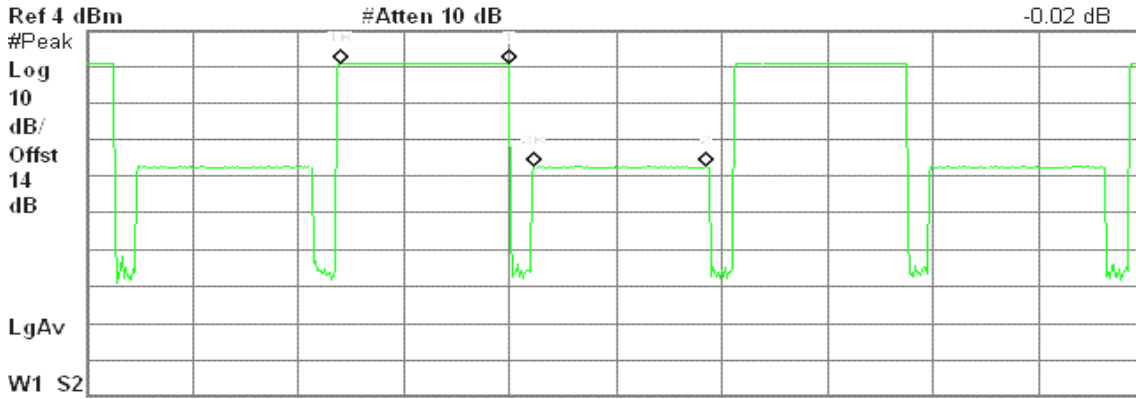

Marker	Trace	Type	X Axis	Amplitude
1R	(1)	Time	2.4 ms	-4.99 dBm
1Δ	(1)	Time	1.6 ms	0.02 dB
2R	(1)	Time	4.233 ms	-33.41 dBm
2Δ	(1)	Time	1.617 ms	-0.02 dB



DH 5

(CH Low)

Agilent 10:37:21 Mar 10, 2008

R T

Δ Mkr1 2.867 ms
0.05 dB

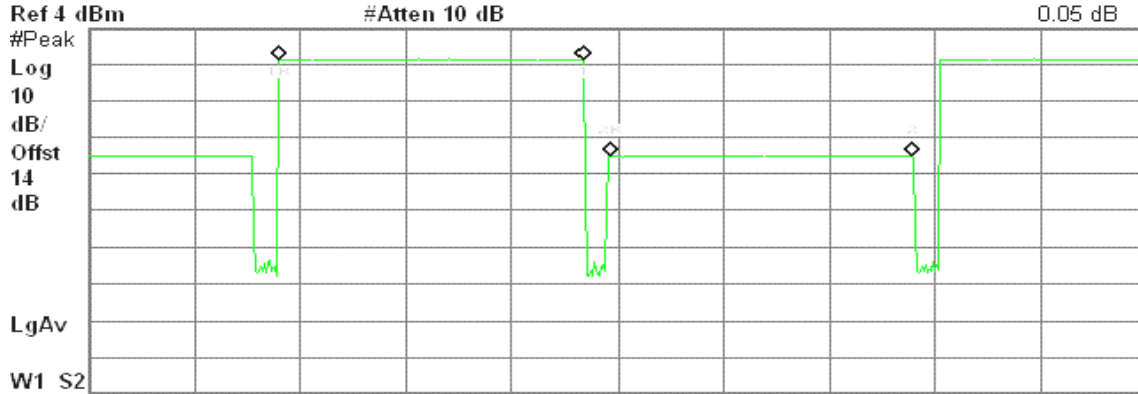

Ref 4 dBm #Atten 10 dB

Center 2.402 000 GHz Span 0 Hz

Res BW 1 MHz #VBW 1 MHz Sweep 10 ms (601 pts)

Marker	Trace	Type	X Axis	Amplitude
1R	(1)	Time	1.8 ms	-4.55 dBm
1Δ	(1)	Time	2.867 ms	0.05 dB
2R	(1)	Time	4.917 ms	-31.01 dBm
2Δ	(1)	Time	2.867 ms	-0.14 dB

(CH Mid)

Agilent 10:38:10 Mar 10, 2008

R T

Δ Mkr2 2.867 ms
-0.19 dB

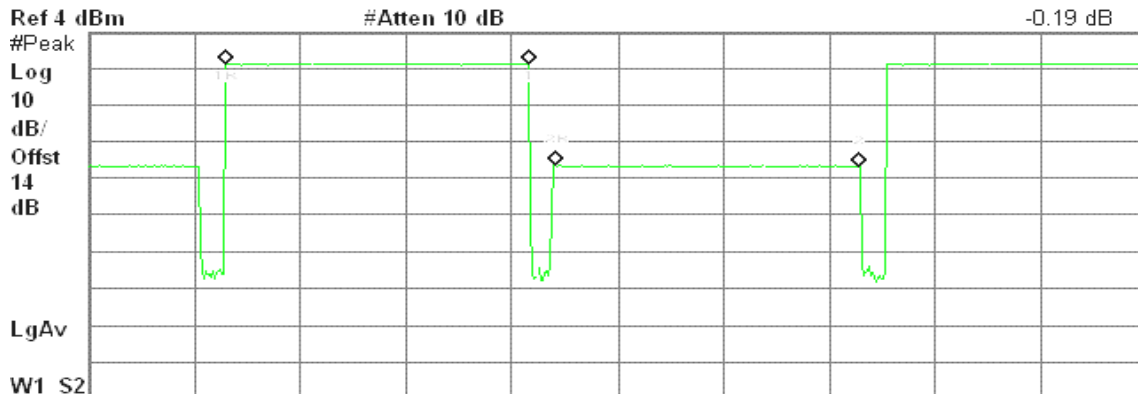

Ref 4 dBm #Atten 10 dB

Center 2.441 000 GHz Span 0 Hz

Res BW 1 MHz #VBW 1 MHz Sweep 10 ms (601 pts)

Marker	Trace	Type	X Axis	Amplitude
1R	(1)	Time	1.3 ms	-4.78 dBm
1Δ	(1)	Time	2.867 ms	-0.06 dB
2R	(1)	Time	4.417 ms	-32.47 dBm
2Δ	(1)	Time	2.867 ms	-0.19 dB



(CH High)

Agilent 10:39:11 Mar 10, 2008

R T

Δ Mkr1 2.883 ms
0.06 dB

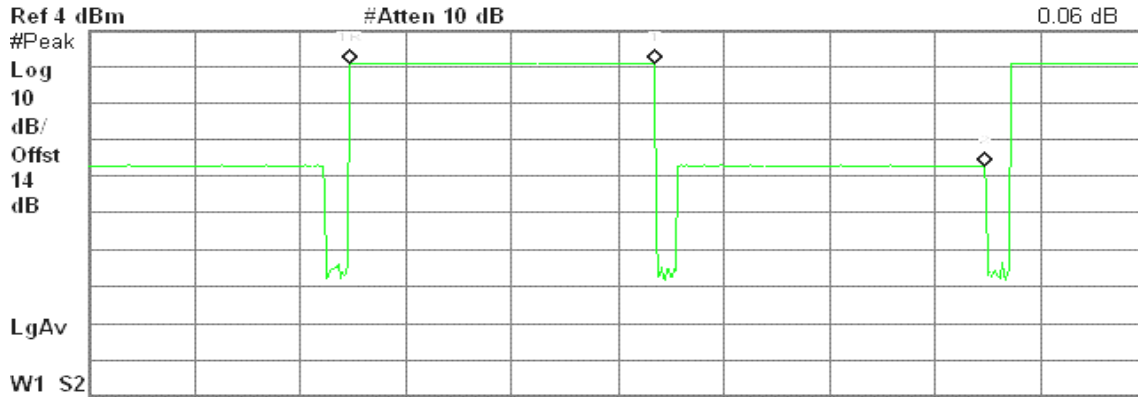

Center 2.480 000 GHz

Span 0 Hz

Res BW 1 MHz

#VBW 1 MHz

Sweep 10 ms (601 pts)

Marker	Trace	Type	X Axis	Amplitude
1R	(1)	Time	2.467 ms	-5.08 dBm
1Δ	(1)	Time	2.883 ms	0.06 dB
2	(1)	Time	8.467 ms	-33.12 dBm



For 8DPSK

DH 1

(CH Low)

Agilent 12:27:23 Mar 10, 2008

R T

Δ Mkr2 383.3 μs
-1.01 dB

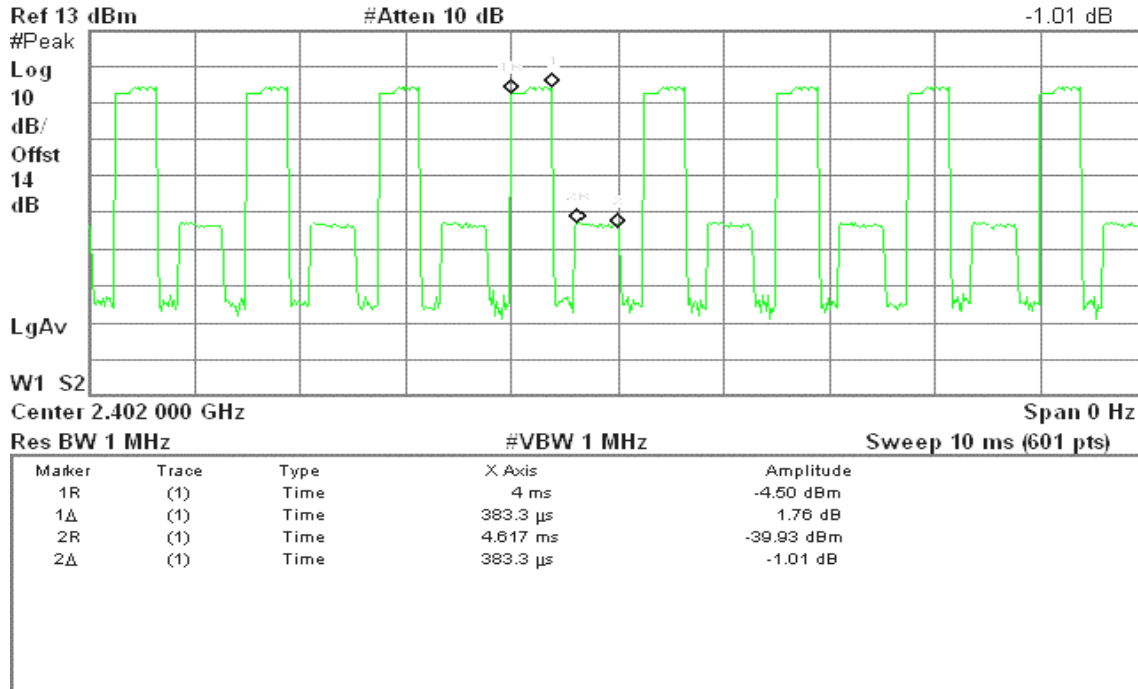

(CH Mid)

Agilent 12:28:15 Mar 10, 2008

R T

Δ Mkr1 383.3 μs
1.56 dB

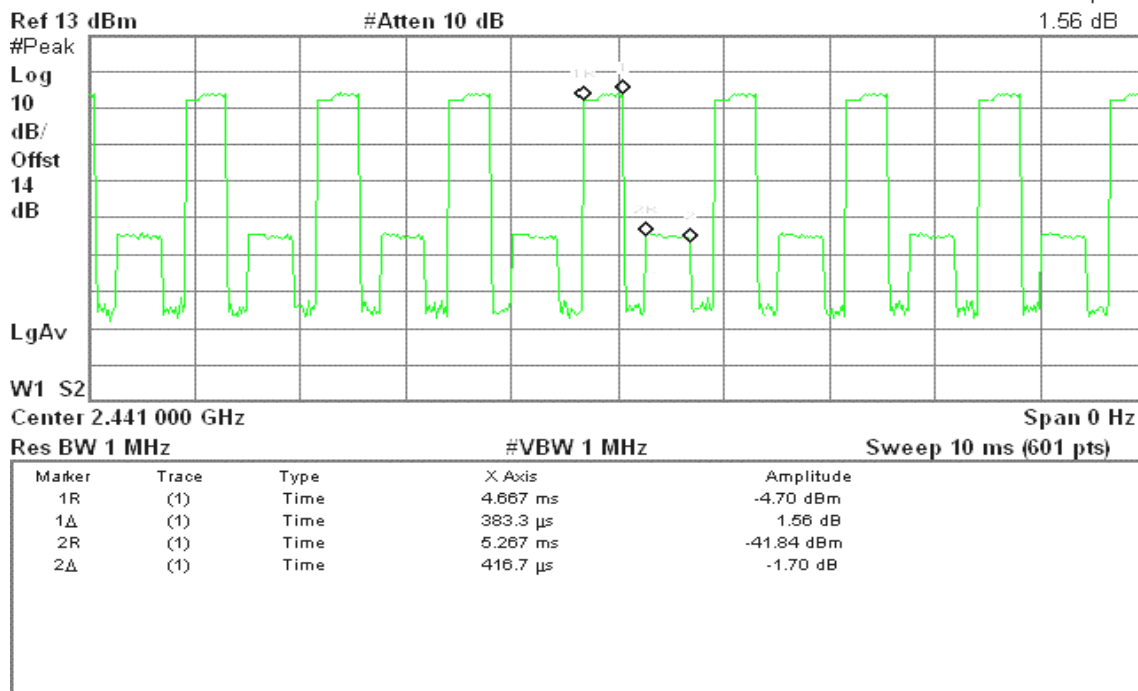



(CH High)

Agilent 12:29:12 Mar 10, 2008

R T

Δ Mkr2 383.3 μs
-0.73 dB



Center 2.480 000 GHz Span 0 Hz
Res BW 1 MHz #VBW 1 MHz Sweep 10 ms (601 pts)

Marker	Trace	Type	X Axis	Amplitude
1R	(1)	Time	5.15 ms	-4.65 dBm
1Δ	(1)	Time	350 μs	1.37 dB
2R	(1)	Time	5.75 ms	-41.85 dBm
2Δ	(1)	Time	383.3 μs	-0.73 dB

DH 3

(CH Low)

Agilent 12:31:35 Mar 10, 2008

R T

Δ Mkr1 1.617 ms
1.37 dB



Center 2.402 000 GHz Span 0 Hz
Res BW 1 MHz #VBW 1 MHz Sweep 10 ms (601 pts)

Marker	Trace	Type	X Axis	Amplitude
1R	(1)	Time	4.633 ms	-4.16 dBm
1Δ	(1)	Time	1.617 ms	1.37 dB
2R	(1)	Time	6.483 ms	-40.41 dBm
2Δ	(1)	Time	1.65 ms	-0.54 dB



(CH Mid)

Agilent 12:30:50 Mar 10, 2008

R T

Δ Mkr2 1.633 ms
-0.61 dB



Center 2.441 000 GHz Res BW 1 MHz #VBW 1 MHz Sweep 10 ms (601 pts) Span 0 Hz

Marker	Trace	Type	X Axis	Amplitude
1R	(1)	Time	3.517 ms	-4.66 dBm
1Δ	(1)	Time	1.617 ms	1.50 dB
2R	(1)	Time	5.383 ms	-41.70 dBm
2Δ	(1)	Time	1.633 ms	-0.61 dB

(CH High)

Agilent 12:30:10 Mar 10, 2008

R T

Δ Mkr1 1.617 ms
1.32 dB

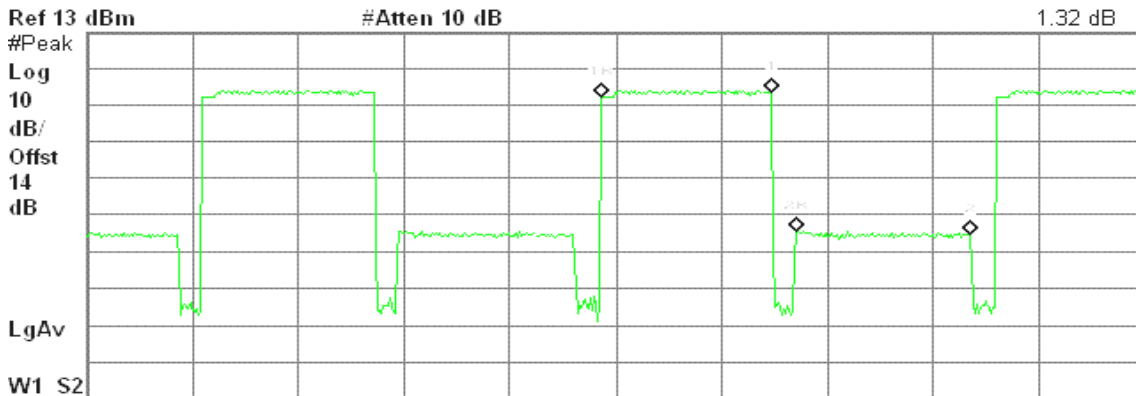

Center 2.480 000 GHz Res BW 1 MHz #VBW 1 MHz Sweep 10 ms (601 pts) Span 0 Hz

Marker	Trace	Type	X Axis	Amplitude
1R	(1)	Time	4.85 ms	-4.63 dBm
1Δ	(1)	Time	1.617 ms	1.32 dB
2R	(1)	Time	6.7 ms	-41.70 dBm
2Δ	(1)	Time	1.65 ms	-0.81 dB



DH 5

(CH Low)

Agilent 12:32:23 Mar 10, 2008

R T

Δ Mkr2 2.883 ms
-0.68 dB

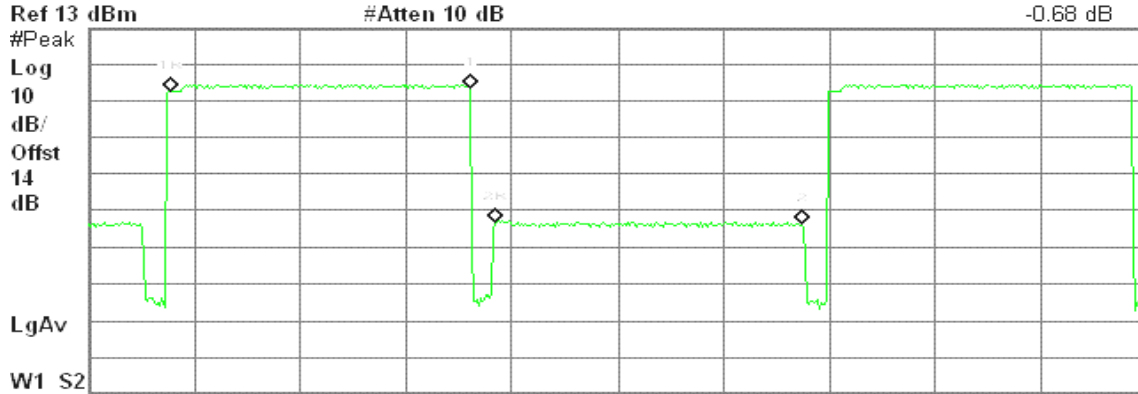

Ref 13 dBm #Atten 10 dB Center 2.402 000 GHz Res BW 1 MHz #VBW 1 MHz Sweep 10 ms (601 pts) Span 0 Hz

Marker	Trace	Type	X Axis	Amplitude
1R	(1)	Time	766.7 μs	-4.15 dBm
1Δ	(1)	Time	2.85 ms	0.90 dB
2R	(1)	Time	3.85 ms	-40.06 dBm
2Δ	(1)	Time	2.883 ms	-0.68 dB

(CH Mid)

Agilent 12:33:05 Mar 10, 2008

R T

Δ Mkr1 2.85 ms
1.47 dB



Ref 13 dBm #Atten 10 dB Center 2.441 000 GHz Res BW 1 MHz #VBW 1 MHz Sweep 10 ms (601 pts) Span 0 Hz

Marker	Trace	Type	X Axis	Amplitude
1R	(1)	Time	1.733 ms	-4.53 dBm
1Δ	(1)	Time	2.85 ms	1.47 dB
2R	(1)	Time	4.833 ms	-41.38 dBm
2Δ	(1)	Time	2.867 ms	-0.57 dB



(CH High)

Agilent 12:33:55 Mar 10, 2008

R T

Δ Mkr2 2.9 ms
-0.24 dB



Res BW 1 MHz #VBW 1 MHz Sweep 10 ms (601 pts)

Marker	Trace	Type	X Axis	Amplitude
1R	(1)	Time	2.317 ms	-4.79 dBm
1Δ	(1)	Time	2.883 ms	0.94 dB
2R	(1)	Time	5.417 ms	-42.12 dBm
2Δ	(1)	Time	2.9 ms	-0.24 dB



7.8 SPURIOUS EMISSIONS

7.8.1 Conducted Measurement

LIMIT

According to §15.247(d), in any 100 kHz bandwidth outside the frequency bands in which the spread spectrum intentional radiator is operating, the radio frequency power that is produced by the intentional radiator shall be at least 20 dB below that in the 100 kHz bandwidth within the band that contains the highest level of the desired power, based on either an RF conducted or a radiated measurement, provided the transmitter demonstrates compliance with the peak conducted power limits. In addition, radiated emissions which fall in the restricted bands, as defined in §15.205(a), must also comply with the radiated emission limits specified in 15.209(a) (see Section 15.205(c)).

Test Configuration

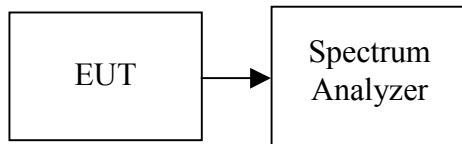

TEST PROCEDURE

Conducted RF measurements of the transmitter output were made to confirm that the EUT antenna port conducted emissions meet the specified limit and to identify any spurious signals that require further investigation or measurements on the radiated emissions site.

The transmitter output is connected to the spectrum analyzer. The resolution bandwidth is set to 100 kHz. The video bandwidth is set to 100 kHz.

Measurements are made over the 30MHz to 26GHz range with the transmitter set to the lowest, middle, and highest channels.

TEST RESULTS

No non-compliance noted



Test Plot
For GFSK
CH Low

Agilent 10:52:03 Mar 10, 2008

R T

Mkr1 2.41 GHz
-8.85 dBm



CH Mid

Agilent 12:11:44 Mar 10, 2008

R T

Mkr1 2.45 GHz
-5.62 dBm

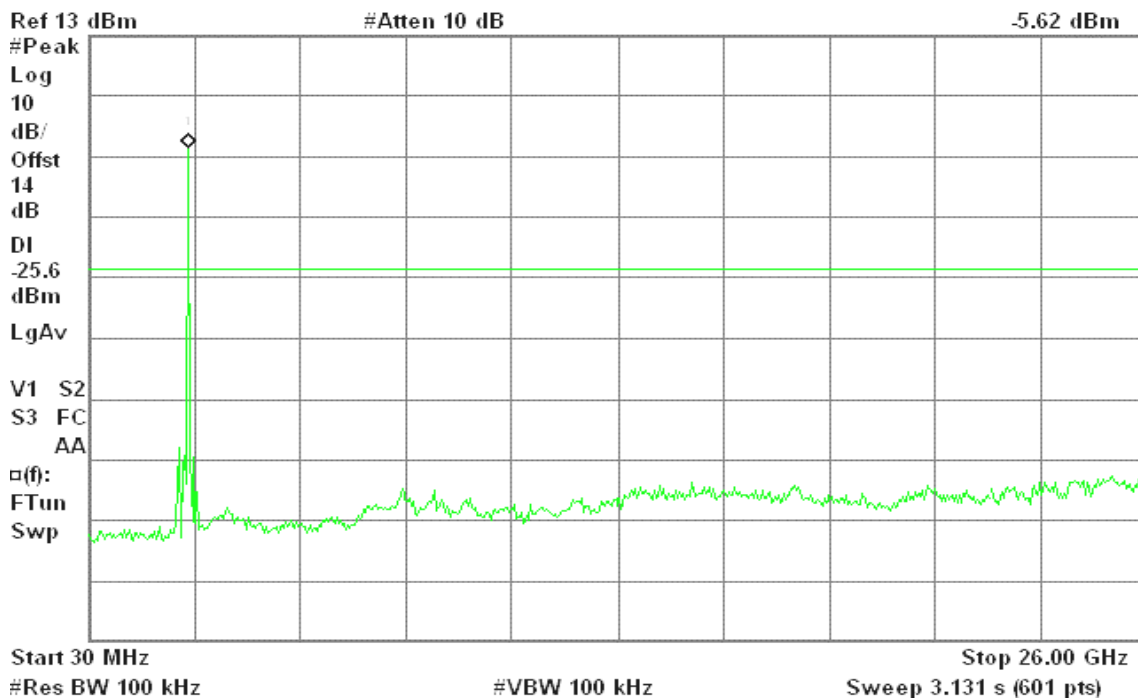



CH High

Agilent 12:15:17 Mar 10, 2008

R T

Mkr1 2.50 GHz
-5.02 dBm





For 8DPSK

CH Low

Agilent 12:54:23 Mar 10, 2008

R T



CH Mid

Agilent 12:55:32 Mar 10, 2008

R T

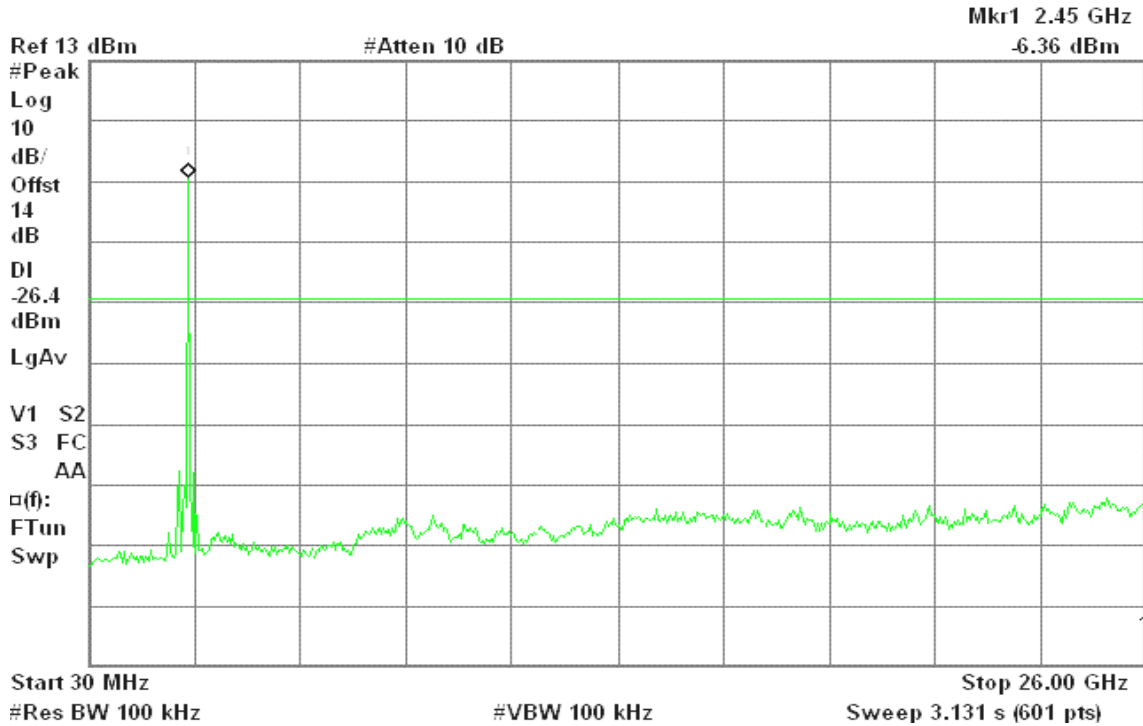



CH High

Agilent 12:56:13 Mar 10, 2008

R T

Mkr1 2.50 GHz
-5.30 dBm





7.8.2 Radiated Emissions

LIMIT

1. According to §15.209(a), except as provided elsewhere in this Subpart, the emissions from an intentional radiator shall not exceed the field strength levels specified in the following table:

Frequency (MHz)	Field Strength (µV/m)	Measurement Distance (m)
30-88	100*	3
88-216	150*	3
216-960	200*	3
Above 960	500	3

Remark: Except as provided in paragraph (g), fundamental emissions from intentional radiators operating under this Section shall not be located in the frequency bands 54-72 MHz, 76-88 MHz, 174-216 MHz or 470-806 MHz. However, operation within these frequency bands is permitted under other sections of this Part, e.g., Sections 15.231 and 15.241.

2. In the emission table above, the tighter limit applies at the band edges.

Frequency (MHz)	Field Strength (µV/m at 3-meter)	Field Strength (dBµV/m at 3-meter)
30-88	100	40
88-216	150	43.5
216-960	200	46
Above 960	500	54

Test Configuration

Below 1 GHz

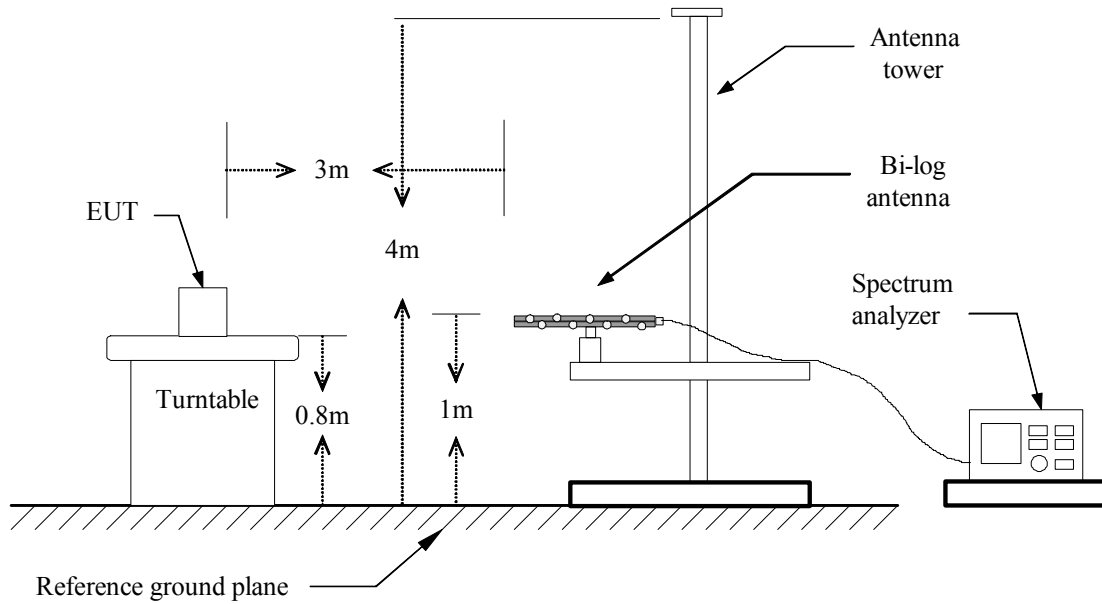

Above 1 GHz

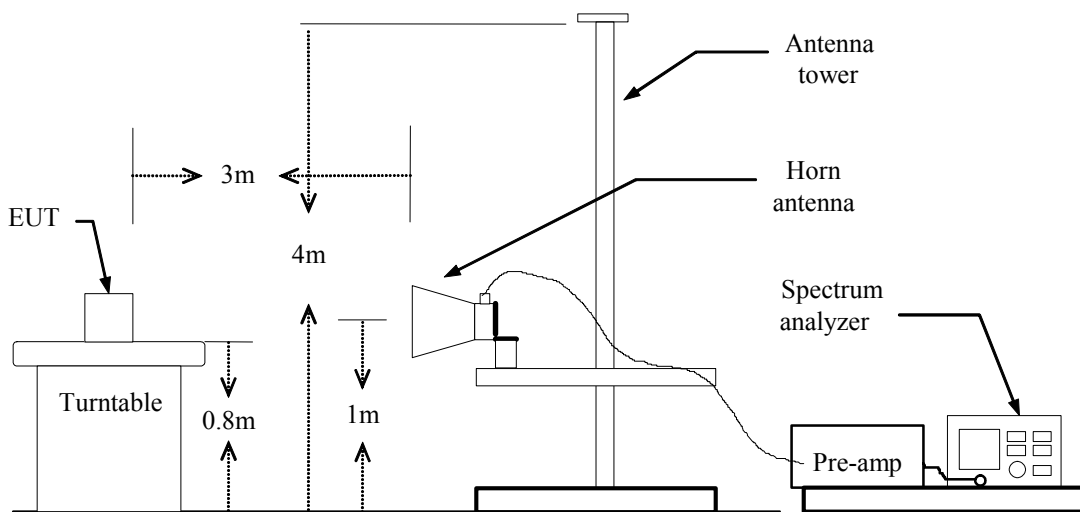



TEST PROCEDURE

1. The EUT is placed on a turntable, which is 0.8m above ground plane.
2. The turntable shall be rotated for 360 degrees to determine the position of maximum emission level.
3. EUT is set 3m away from the receiving antenna, which is varied from 1m to 4m to find out the highest emissions.
4. Maximum procedure was performed on the six highest emissions to ensure EUT compliance.
5. And also, each emission was to be maximized by changing the polarization of receiving antenna both horizontal and vertical.
6. Set the spectrum analyzer in the following setting as:
Below 1GHz:
RBW=100kHz / VBW=300kHz / Sweep=AUTO
Above 1GHz:
(a) PEAK: RBW=VBW=1MHz / Sweep=AUTO
(b) AVERAGE: RBW=1MHz / VBW=10Hz / Sweep=AUTO
7. Repeat above procedures until the measurements for all frequencies are complete.

**TEST RESULTS***No non-compliance noted.***Below 1 GHz****Operation Mode:** Normal Link**Test Date:** March 11, 2008**Temperature:** 25°C**Tested by:** Mimic Yang**Humidity:** 55 % RH**Polarity:** Ver. / Hor.

Frequency (MHz)	Ant.Pol. (H/V)	Reading (dBuV)	Correction Factor (dB/m)	Result (dBuV/m)	Limit (dBuV/m)	Margin (dB)	Remark
67.18	V	55.48	-19.25	36.23	40.00	-3.77	Peak
127.00	V	51.67	-13.15	38.52	43.50	-4.98	Peak
152.87	V	51.70	-14.20	37.50	43.50	-6.00	Peak
398.60	V	38.57	-10.01	28.55	46.00	-17.45	Peak
437.40	V	36.61	-8.90	27.71	46.00	-18.29	Peak
666.97	V	35.98	-4.89	31.09	46.00	-14.91	Peak
67.18	H	49.29	-19.25	30.03	40.00	-9.97	Peak
120.53	H	42.89	-12.88	30.01	43.50	-13.49	Peak
151.25	H	43.35	-14.15	29.20	43.50	-14.30	Peak
374.35	H	42.62	-10.20	32.41	46.00	-13.59	Peak
400.22	H	39.63	-10.00	29.62	46.00	-16.38	Peak
498.83	H	39.84	-7.86	31.98	46.00	-14.02	Peak

Remark:

1. *Measuring frequencies from 30 MHz to the 1GHz.*
2. *Radiated emissions measured in frequency range from 30 MHz to 1000MHz were made with an instrument using peak/quasi-peak detector mode.*
3. *Quasi-peak test would be performed if the peak result were greater than the quasi-peak limit or as required by the applicant.*
4. *Measurements above show only up to 6 maximum emissions noted, or would be lesser; with " N/A " remark, if no specific emissions from the EUT are recorded (ie: margin>20dB from the applicable limit) and considered that's already beyond the background noise floor.*
5. *Margin (dB) = Remark result (dBuV/m) – Quasi-peak limit (dBuV/m).*



Above 1 GHz

For GFSK

Operation Mode: TX / CH Low

Test Date: March 11, 2008

Temperature: 25°C

Tested by: Mimic Yang

Humidity: 55 % RH

Polarity: Ver. / Hor.

Frequency (MHz)	Ant.Pol. (H/V)	Reading (Peak) (dBuV)	Reading (Average) (dBuV)	Correction Factor (dB/m)	Result (Peak) (dBuV/m)	Result (Average) (dBuV/m)	Limit (Peak) (dBuV/m)	Limit (Average) (dBuV/m)	Margin (dB)	Remark
1423.33	V	60.04	---	-10.10	49.94	---	74.00	54.00	-4.06	Peak
N/A										
1450.00	H	59.68	---	-10.06	49.62	---	74.00	54.00	-4.38	Peak
4808.33	H	54.86	46.73	0.54	55.40	47.27	74.00	54.00	-6.73	AVG
N/A										

Remark:

1. Measuring frequencies from 1 GHz to the 10th harmonic of highest fundamental frequency.
2. Radiated emissions measured in frequency above 1000MHz were made with an instrument using peak/average detector mode.
3. Average test would be performed if the peak result were greater than the average limit or as required by the applicant.
4. Data of measurement within this frequency range shown “ --- ” in the table above means the reading of emissions are attenuated more than 20dB below the permissible limits or the field strength is too small to be measured.
5. Measurements above show only up to 6 maximum emissions noted, or would be lesser, with “ N/A ” remark, if no specific emissions from the EUT are recorded (ie: margin>20dB from the applicable limit) and considered that's already beyond the background noise floor.
6. Margin (dB) = Remark result (dBuV/m) – Average limit (dBuV/m).



Operation Mode: TX / CH Mid

Test Date: March 11, 2008

Temperature: 25°C

Tested by: Mimic Yang

Humidity: 55 % RH

Polarity: Ver. / Hor.

Frequency (MHz)	Ant.Pol. (H/V)	Reading (Peak) (dBuV)	Reading (Average) (dBuV)	Correction Factor (dB/m)	Result (Peak) (dBuV/m)	Result (Average) (dBuV/m)	Limit (Peak) (dBuV/m)	Limit (Average) (dBuV/m)	Margin (dB)	Remark
1416.67	V	60.27	---	-10.11	50.16	---	74.00	54.00	-3.84	Peak
N/A										
1476.67	H	59.69	---	-10.01	49.67	---	74.00	54.00	-4.33	Peak
N/A										

Remark:

1. Measuring frequencies from 1 GHz to the 10th harmonic of highest fundamental frequency.
2. Radiated emissions measured in frequency above 1000MHz were made with an instrument using peak/average detector mode.
3. Average test would be performed if the peak result were greater than the average limit or as required by the applicant.
4. Data of measurement within this frequency range shown " --- " in the table above means the reading of emissions are attenuated more than 20dB below the permissible limits or the field strength is too small to be measured.
5. Measurements above show only up to 6 maximum emissions noted, or would be lesser, with " N/A " remark, if no specific emissions from the EUT are recorded (ie: margin>20dB from the applicable limit) and considered that's already beyond the background noise floor.
6. Margin (dB) = Remark result (dBuV/m) – Average limit (dBuV/m).



Operation Mode: TX / CH High

Test Date: March 11, 2008

Temperature: 25°C

Tested by: Mimic Yang

Humidity: 55 % RH

Polarity: Ver. / Hor.

Frequency (MHz)	Ant.Pol. (H/V)	Reading (Peak) (dBuV)	Reading (Average) (dBuV)	Correction Factor (dB/m)	Result (Peak) (dBuV/m)	Result (Average) (dBuV/m)	Limit (Peak) (dBuV/m)	Limit (Average) (dBuV/m)	Margin (dB)	Remark
1486.67	V	59.08	---	-10.00	49.09	---	74.00	54.00	-4.91	Peak
N/A										
1490.00	H	59.16	---	-9.99	49.17	---	74.00	54.00	-4.83	Peak
N/A										

Remark:

1. Measuring frequencies from 1 GHz to the 10th harmonic of highest fundamental frequency.
2. Radiated emissions measured in frequency above 1000MHz were made with an instrument using peak/average detector mode.
3. Average test would be performed if the peak result were greater than the average limit or as required by the applicant.
4. Data of measurement within this frequency range shown " --- " in the table above means the reading of emissions are attenuated more than 20dB below the permissible limits or the field strength is too small to be measured.
5. Measurements above show only up to 6 maximum emissions noted, or would be lesser; with " N/A " remark, if no specific emissions from the EUT are recorded (ie: margin > 20dB from the applicable limit) and considered that's already beyond the background noise floor.
6. Margin (dB) = Remark result (dBuV/m) – Average limit (dBuV/m).



For 8DPSK

Operation Mode: TX / CH Low

Test Date: March 12, 2008

Temperature: 25°C

Tested by: Mimic Yang

Humidity: 55 % RH

Polarity: Ver. / Hor.

Frequency (MHz)	Ant.Pol. (H/V)	Reading (Peak) (dBuV)	Reading (Average) (dBuV)	Correction Factor (dB/m)	Result (Peak) (dBuV/m)	Result (Average) (dBuV/m)	Limit (Peak) (dBuV/m)	Limit (Average) (dBuV/m)	Margin (dB)	Remark
1533.33	V	59.84	---	-9.64	50.19	---	74.00	54.00	-3.81	Peak
N/A										
1386.67	H	59.37	---	-10.16	49.21	---	74.00	54.00	-4.79	Peak
N/A										

Remark:

1. Measuring frequencies from 1 GHz to the 10th harmonic of highest fundamental frequency.
2. Radiated emissions measured in frequency above 1000MHz were made with an instrument using peak/average detector mode.
3. Average test would be performed if the peak result were greater than the average limit.
4. Data of measurement within this frequency range shown " --- " in the table above means the reading of emissions are attenuated more than 20dB below the permissible limits or the field strength is too small to be measured.
5. Measurements above show only up to 6 maximum emissions noted, or would be lesser; with " N/A " remark, if no specific emissions from the EUT are recorded (ie: margin>20dB from the applicable limit) and considered that's already beyond the background noise floor.
6. Margin (dB) = Remark result (dBuV/m) – Average limit (dBuV/m).



Operation Mode: TX / CH Mid

Test Date: March 12, 2008

Temperature: 25°C

Tested by: Mimic Yang

Humidity: 55 % RH

Polarity: Ver. / Hor.

Frequency (MHz)	Ant.Pol. (H/V)	Reading (Peak) (dBuV)	Reading (Average) (dBuV)	Correction Factor (dB/m)	Result (Peak) (dBuV/m)	Result (Average) (dBuV/m)	Limit (Peak) (dBuV/m)	Limit (Average) (dBuV/m)	Margin (dB)	Remark
1350.00	V	59.75	---	-10.22	49.53	---	74.00	54.00	-4.47	Peak
N/A										
1476.67	H	59.67	---	-10.01	49.66	---	74.00	54.00	-4.34	Peak
N/A										

Remark:

1. Measuring frequencies from 1 GHz to the 10th harmonic of highest fundamental frequency.
2. Radiated emissions measured in frequency above 1000MHz were made with an instrument using peak/average detector mode.
3. Average test would be performed if the peak result were greater than the average limit.
4. Data of measurement within this frequency range shown " --- " in the table above means the reading of emissions are attenuated more than 20dB below the permissible limits or the field strength is too small to be measured.
5. Measurements above show only up to 6 maximum emissions noted, or would be lesser, with " N/A " remark, if no specific emissions from the EUT are recorded (ie: margin > 20dB from the applicable limit) and considered that's already beyond the background noise floor.
6. Margin (dB) = Remark result (dBuV/m) – Average limit (dBuV/m).



Operation Mode: TX / CH High

Test Date: March 12, 2008

Temperature: 25°C

Tested by: Mimic Yang

Humidity: 55 % RH

Polarity: Ver. / Hor.

Frequency (MHz)	Ant.Pol. (H/V)	Reading (Peak) (dBuV)	Reading (Average) (dBuV)	Correction Factor (dB/m)	Result (Peak) (dBuV/m)	Result (Average) (dBuV/m)	Limit (Peak) (dBuV/m)	Limit (Average) (dBuV/m)	Margin (dB)	Remark
1460.00	V	59.70	---	-10.04	49.66	---	74.00	54.00	-4.34	Peak
N/A										
1426.67	H	60.90	---	-10.09	50.81	---	74.00	54.00	-3.19	Peak
N/A										

Remark:

1. Measuring frequencies from 1 GHz to the 10th harmonic of highest fundamental frequency.
2. Radiated emissions measured in frequency above 1000MHz were made with an instrument using peak/average detector mode.
3. Average test would be performed if the peak result were greater than the average limit.
4. Data of measurement within this frequency range shown " --- " in the table above means the reading of emissions are attenuated more than 20dB below the permissible limits or the field strength is too small to be measured.
5. Measurements above show only up to 6 maximum emissions noted, or would be lesser, with " N/A " remark, if no specific emissions from the EUT are recorded (ie: margin > 20dB from the applicable limit) and considered that's already beyond the background noise floor.
6. Margin (dB) = Remark result (dBuV/m) – Average limit (dBuV/m).



7.9 POWERLINE CONDUCTED EMISSIONS

LIMIT

According to §15.207(a), except as shown in paragraphs (b) and (c) of this section, for an intentional radiator that is designed to be connected to the public utility (AC) power line, the radio frequency voltage that is conducted back onto the AC power line on any frequency or frequencies within the band 150 kHz to 30 MHz shall not exceed the limits in the following table, as measured using a 50 μ H/50 ohms line impedance stabilization network (LISN). Compliance with the provisions of this paragraph shall be based on the measurement of the radio frequency voltage between each power line and ground at the power terminal. The lower limit applies at the boundary between the frequency ranges.

Frequency Range (MHz)	Limits (dB μ V)	
	Quasi-peak	Average
0.15 to 0.50	66 to 56*	56 to 46*
0.50 to 5	56	46
5 to 30	60	50

* Decreases with the logarithm of the frequency.

Test Configuration

See test photographs attached in Appendix II for the actual connections between EUT and support equipment.

TEST PROCEDURE

1. The EUT was placed on a table, which is 0.8m above ground plane.
2. Maximum procedure was performed on the six highest emissions to ensure EUT compliance.
3. Repeat above procedures until all frequency measured were complete.



Test Plots

Conducted emissions (Line 1)

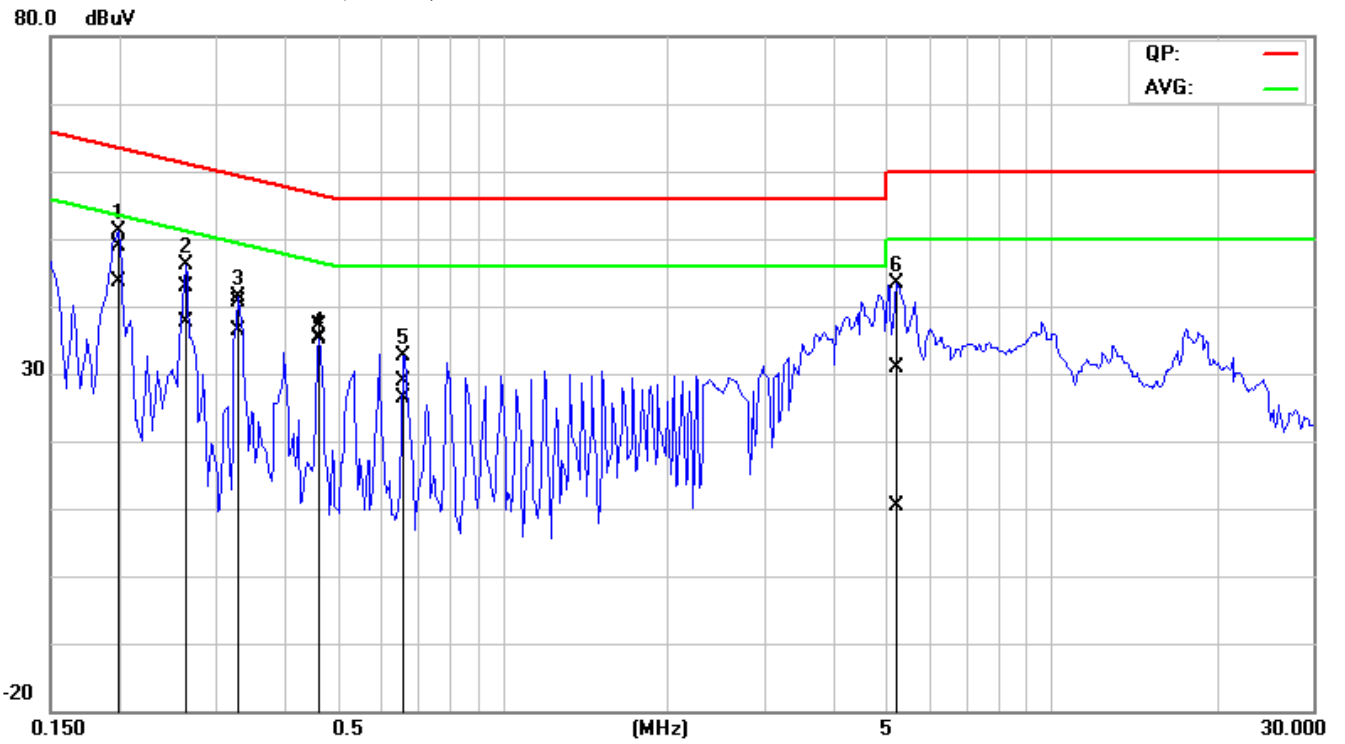

Conducted emissions (Line 2)

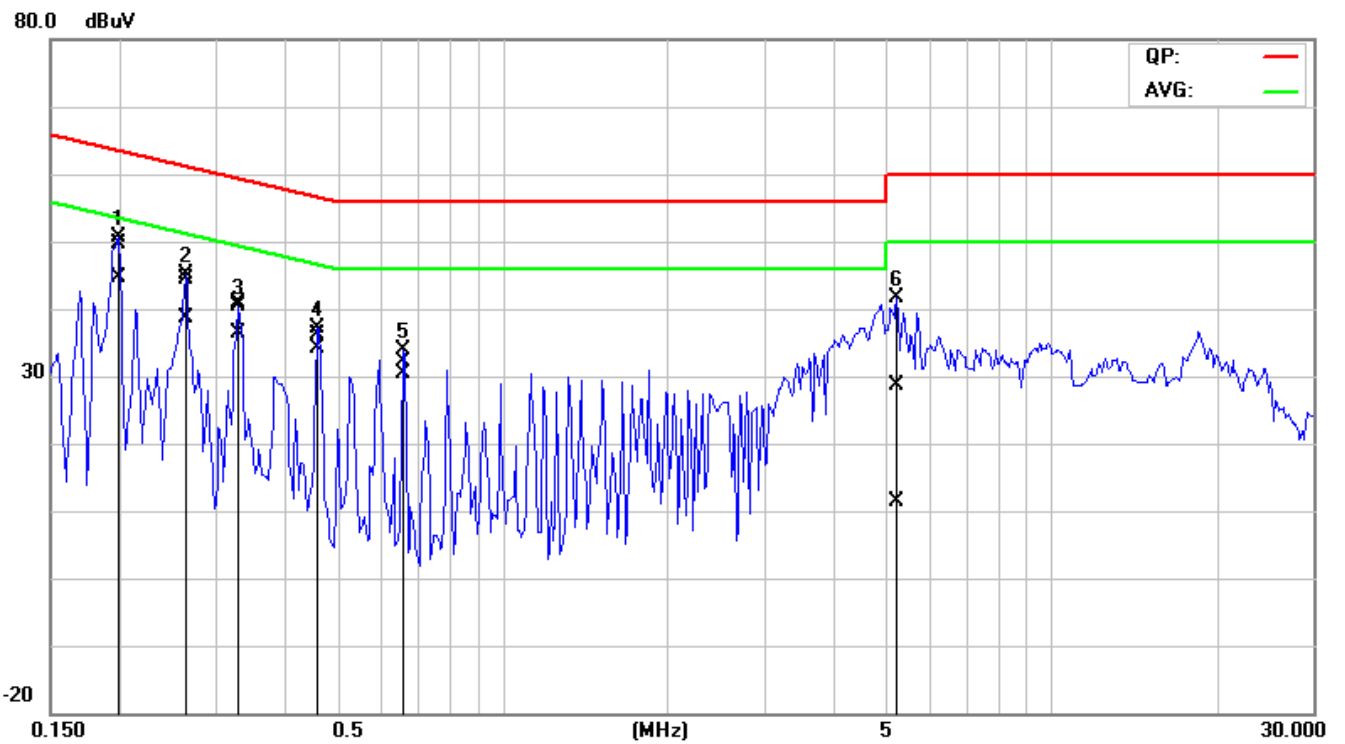



APPENDIX I RADIO FREQUENCY EXPOSURE

LIMIT

According to §15.247(i), systems operating under the provisions of this section shall be operated in a manner that ensures that the public is not exposed to radio frequency energy levels in excess of the Commission's guidelines. See § 1.1307(b)(1) of this chapter.

EUT Specification

EUT	3.5G Pocket PC Phone
Frequency band (Operating)	<input type="checkbox"/> WLAN: 2.412GHz ~ 2.462GHz <input type="checkbox"/> WLAN: 5.18GHz ~ 5.32GHz / 5.50GHz ~ 5.70GHz <input type="checkbox"/> WLAN: 5.745GHz ~ 5.825GHz <input checked="" type="checkbox"/> Others: <u>Bluetooth: 2.402GHz ~ 2.480GHz</u>
Device category	<input checked="" type="checkbox"/> Portable (<20cm separation) <input type="checkbox"/> Mobile (>20cm separation) <input type="checkbox"/> Others _____
Exposure classification	<input type="checkbox"/> Occupational/Controlled exposure ($S = 5mW/cm^2$) <input checked="" type="checkbox"/> General Population/Uncontrolled exposure ($S = 1mW/cm^2$)
Antenna diversity	<input checked="" type="checkbox"/> Single antenna <input type="checkbox"/> Multiple antennas <input type="checkbox"/> Tx diversity <input type="checkbox"/> Rx diversity <input type="checkbox"/> Tx/Rx diversity
Max. output power	-6.23 dBm (0.24mW)
Antenna gain (Max)	1.66 dBi (Numeric gain: 1.47)
Evaluation applied	<input type="checkbox"/> MPE Evaluation <input checked="" type="checkbox"/> SAR Evaluation* <input type="checkbox"/> N/A

Remark:

1. The maximum output power is -6.23 dBm (0.24mW) at 2402MHz (with 1.47 numeric antenna gain.)
2. DTS device is not subject to routine RF evaluation; MPE estimate is used to justify the compliance.
3. For mobile or fixed location transmitters, no SAR consideration applied. The maximum power density is $1.0 mW/cm^2$ even if the calculation indicates that the power density would be larger.

TEST RESULTS

No non-compliance noted.

Remark: Please refer to the separated SAR report.