

TEST REPORT

Test report no.: 1-5176/12-01-02-B



Testing laboratory

CETECOM ICT Services GmbH
Untertuerkheimer Strasse 6 – 10
66117 Saarbruecken / Germany
Phone: + 49 681 5 98 - 0
Fax: + 49 681 5 98 - 9075
Internet: <http://www.cetecom.com>
e-mail: ict@cetecom.com

Accredited Testing Laboratory:

The testing laboratory (area of testing) is accredited according to DIN EN ISO/IEC 17025 (2005) by the Deutsche Akkreditierungsstelle GmbH (DAkkS). The accreditation is valid for the scope of testing procedures as stated in the accreditation certificate with the registration number: D-PL-12076-01-01
Area of Testing: Radio/Satellite Communications

Applicant

FEIG ELECTRONIC GmbH
Lange Str. 4
35781 Weilburg-Waldhausen / GERMANY
Phone: +49 6471 31 09-0
Contact: Frieder Heinze
Phone: +49 6471 310-90

Manufacturer

FEIG ELECTRONIC GmbH
Lange Str. 4
35781 Weilburg-Waldhausen / GERMANY

Test standard/s

47 CFR Part 15	Title 47 of the Code of Federal Regulations; Chapter I Part 15 - Radio frequency devices
RSS – 210 Issue 8	Spectrum Management and Telecommunications – Radio Standards Specification Low-power Licence-exempt Radiocommunication Devices (All frequency Bands): Category I equipment

For further applied test standards please refer to section 3 of this test report.

Test Item

Kind of test item:	Wireless Safety System for industrial doors
Model name:	TST PD_FSAS 250 KBit
FCC ID:	PJMTSTPDFSASK
IC:	6633A-TSTPDFSASK
Frequency:	ISM band 2400 MHz to 2483.5 MHz (lowest channel 2402 MHz, highest channel 2480 MHz)
Technology tested:	Proprietary hopping system
Antenna:	External antenna
Power Supply:	24.0 V DC by external power supply
Temperature Range:	-40°C to +70 °C



This test report is electronically signed and valid without handwriting signature. For verification of the electronic signatures, the public keys can be requested at the testing laboratory.

Test report authorised:

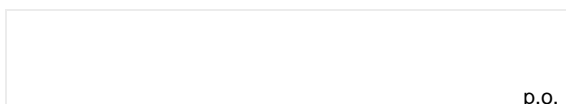
p.o.

Stefan Bös
Senior Testing Manager

Test performed:



Tobias Wittenmeier

1 Table of contents

1 Table of contents2

2 General information3

 2.1 Notes and disclaimer3

 2.2 Application details.....3

3 Test standard/s3

4 Test environment.....4

5 Test item4

6 Test laboratories sub-contracted4

7 Summary of measurement results5

 7.1 RSP100 test report cover sheet / performance test data6

8 RF measurements7

 8.1 Description of test setup7

 8.1.1 Radiated measurements.....7

 8.1.2 Additional comments8

9 Measurement results.....9

 9.1 Field strength of emissions (wanted signal)9

 9.2 Occupied bandwidth (99% bandwidth)11

 9.3 Field strength of emissions (radiated spurious).....15

 9.4 Conducted spurious emissions < 30 MHz32

 9.1 Results receiver mode34

 9.1.1 Spurious emissions radiated – receiver mode34

10 Test equipment and ancillaries used for tests.....40

11 Observations41

Annex A Photographs of the test setup42

Annex B External photographs of the EUT.....46

Annex C Internal photographs of the EUT53

Annex D Document history58

Annex E Further information.....58

Annex F Accreditation Certificate59

2 General information

2.1 Notes and disclaimer

The test results of this test report relate exclusively to the test item specified in this test report. CETECOM ICT Services GmbH does not assume responsibility for any conclusions and generalizations drawn from the test results with regard to other specimens or samples of the type of the equipment represented by the test item.

The test report may only be reproduced or published in full. Reproduction or publication of extracts from the report requires the prior written approval of CETECOM ICT Services GmbH.

The testing service provided by CETECOM ICT Services GmbH has been rendered under the current "General Terms and Conditions for CETECOM ICT Services GmbH".

CETECOM ICT Services GmbH will not be liable for any loss or damage resulting from false, inaccurate, inappropriate or incomplete product information provided by the customer.

Under no circumstances does the CETECOM ICT Services GmbH test report include any endorsement or warranty regarding the functionality, quality or performance of any other product or service provided.

Under no circumstances does the CETECOM ICT Services GmbH test report include or imply any product or service warranties from CETECOM ICT Services GmbH, including, without limitation, any implied warranties of merchantability, fitness for purpose, or non-infringement, all of which are expressly disclaimed by CETECOM ICT Services GmbH.

All rights and remedies regarding vendor's products and services for which CETECOM ICT Services GmbH has prepared this test report shall be provided by the party offering such products or services and not by CETECOM ICT Services GmbH.

In no case this test report can be considered as a Letter of Approval.

This test report is electronically signed and valid without handwritten signature. For verification of the electronic signatures, the public keys can be requested at the testing laboratory.

2.2 Application details

Date of receipt of order:	2012-08-14
Date of receipt of test item:	2012-08-27
Start of test:	2012-08-28
End of test:	2012-08-30
Person(s) present during the test:	-/-

3 Test standard/s

Test standard	Date	Test standard description
47 CFR Part 15	2010-10	Title 47 of the Code of Federal Regulations; Chapter I Part 15 - Radio frequency devices
RSS – 210 Issue 8	2010-12	Spectrum Management and Telecommunications – Radio Standards Specification Low-power Licence-exempt Radiocommunication Devices (All frequency Bands): Category I equipment

4 Test environment

Temperature:	T_{nom}	+22 °C during room temperature tests
	T_{max}	+70 °C during high temperature tests
	T_{min}	-40 °C during low temperature tests
Relative humidity content:		55 %
Barometric pressure:		not relevant for this kind of testing
Power supply:	V_{nom}	24.0 V DC by external power supply
	V_{max}	-/- V
	V_{min}	-/- V

5 Test item

Kind of test item	:	Wireless Safety System for industrial doors
Type identification	:	TST PD_FSAS 250 KBit
S/N serial number	:	-/-
HW hardware status	:	FE636 + FE637
SW software status	:	PDFSAS-ST-V00-04
Frequency band [MHz]	:	ISM band 2400 MHz to 2483.5 MHz (lowest channel 2402 MHz, highest channel 2480 MHz)
Type of modulation	:	GFSK
Number of channels	:	40
Antenna	:	External antenna
Power supply	:	24.0 V DC by external power supply
Temperature range	:	-40°C to +70 °C

6 Test laboratories sub-contracted

None

7 Summary of measurement results

- No deviations from the technical specifications were ascertained
- There were deviations from the technical specifications ascertained

TC Identifier	Description	Verdict	Date	Remark
RF-Testing	47 CFR Part 15	Passed	2012-10-04	-/-
RF-Testing	RSS 210	Passed	2012-09-04	-/-

Test specification clause	Test case	Temperature conditions	Power source voltages	Pass	Fail	NA	NP	Results
§15.249(a)	Field strength of emissions (wanted signal)	Nominal	Nominal	<input checked="" type="checkbox"/>	<input type="checkbox"/>	<input type="checkbox"/>	<input type="checkbox"/>	complies
§2.1049	Occupied bandwidth (99% bandwidth)	Nominal	Nominal	<input checked="" type="checkbox"/>	<input type="checkbox"/>	<input type="checkbox"/>	<input type="checkbox"/>	complies
§15.209(a) / §15.249(b)(1)(2)(3)	Field strength of emissions (spurious)	Nominal	Nominal	<input checked="" type="checkbox"/>	<input type="checkbox"/>	<input type="checkbox"/>	<input type="checkbox"/>	complies
§15.207(a)	Conducted emissions < 30 MHz	Nominal	Nominal	<input checked="" type="checkbox"/>	<input type="checkbox"/>	<input type="checkbox"/>	<input type="checkbox"/>	complies
§15.109	Field strength of emissions (spurious)	Nominal	Nominal	<input checked="" type="checkbox"/>	<input type="checkbox"/>	<input type="checkbox"/>	<input type="checkbox"/>	complies

Note: NA = Not Applicable; NP = Not Performed

7.1 RSP100 test report cover sheet / performance test data

Test report number	:	1-5176/12-01-02-B
Equipment model number	:	TST PD_FSAS 250 KBit
Certification number	:	6633A-TSTPDFSASK
Manufacturer (complete address)	:	FEIG ELECTRONIC GmbH Lange Str. 4 35781 Weilburg-Waldhausen / GERMANY
Tested to radio standards specification no.	:	RSS 210, Issue 8, Annex 8
Open area test site IC No.	:	IC 3462C-1
Frequency range	:	ISM band 2400 MHz to 2483.5 MHz (lowest channel 2402 MHz, highest channel 2480 MHz)
Field strength of the fundamental [dB μ V] (max.):		EIRP: 90.66 (highest channel) @ 3m distance
Occupied bandwidth (99%-BW) [kHz]	:	1033.97 (highest channel)
Type of modulation	:	GFSK modulation.
Emission designator (TRC-43)	:	1M03FXD (GFSK modulation)
Antenna information	:	External antenna
Transmitter spurious (worst case) [dB μ V/m @ 3m]:		48.14 @ 25.6 GHz
Receiver spurious (worst case) [dB μ V/m @ 3m]:		37.79 @ 2790 MHz

ATTESTATION:

DECLARATION OF COMPLIANCE:

I attest that the testing was performed or supervised by me; that the test measurements were made in accordance with the above-mentioned Industry Canada standard(s); and that the equipment identified in this application has been subjected to all the applicable test conditions specified in the Industry Canada standards and all of the requirements of the standard have been met.

Laboratory manager:

2012-10-04

Date

Tobias Wittenmeier

Name



Signature

8 RF measurements

8.1 Description of test setup

8.1.1 Radiated measurements

The radiated measurements are performed in vertical and horizontal plane in the frequency range from 9 kHz to 25 GHz in semi-anechoic chambers. The EUT is positioned on a non-conductive support with a height of 0.80 m above a conductive ground plane that covers the whole chamber. The receiving antennas are confirmed with specifications ANSI C63.2-1996 clause 15 and ANSI C63.4-2009 clause 4.1.5. These antennas can be moved over the height range between 1.0 m and 4.0 m in order to search for maximum field strength emitted from EUT. The measurement distances between EUT and receiving antennas are indicated in the test setups for the various frequency ranges. For each measurement, the EUT is rotated in all three axes until the maximum field strength is received. The wanted and unwanted emissions are received by spectrum analyzers where the detector modes and resolution bandwidths over various frequency ranges are set according to requirement ANSI C63-4-2009 clause 4.2.

Antennas are confirmed with ANSI C63.2-1996 item 15.

Semi anechoic chamber

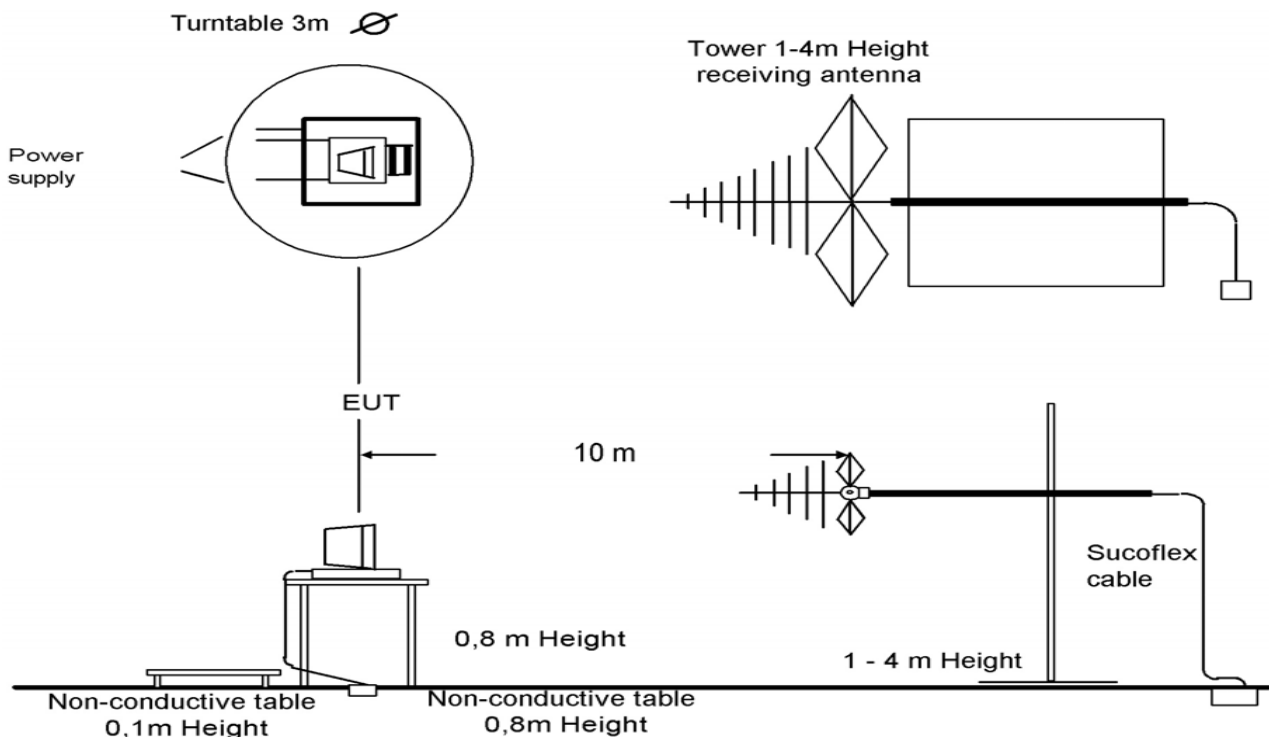

Picture 1: Diagram radiated measurements

9 kHz - 30 MHz:	active loop antenna
30 MHz – 1 GHz:	tri-log antenna
> 1 GHz:	horn antenna

The EUT is powered by an external power supply with nominal voltage

8.1.2 Additional comments

Reference documents: None

Special test descriptions: None

Configuration descriptions: None

Test mode: Normal operation, no special test mode available.

Special software is used.

9 Measurement results

9.1 Field strength of emissions (wanted signal)

Description:

Measurement of the maximum radiated field strength of the wanted signal.

Measurement:

Measurement parameter	
Detector:	Pos-Peak
Sweep time:	Auto
Video bandwidth:	Auto
Resolution bandwidth:	1 MHz
Span:	max. 100 MHz
Trace-Mode:	Max Hold

Limits:

FCC		
CFR Part 15.249(a)		
Field strength of emissions		
The field strength of emissions from intentional radiators operated within these frequency bands shall comply with the following:		
Frequency [MHz]	Field Strength [dB μ V/m]	Measurement distance
902 – 928 MHz	94	3

Result:Lowest channel:

Test condition	Maximum field strength	
	Frequency [MHz]	Field strength [dB μ V/m] @ 3 m
T_{nom} / V_{nom}	2402	89.87
Measurement uncertainty	± 3 dB	

Middle channel:

Test condition	Maximum field strength	
	Frequency [MHz]	Field strength [dB μ V/m] @ 3 m
T_{nom} / V_{nom}	2442	90.10
Measurement uncertainty	± 3 dB	

Highest channel:

Test condition	Maximum field strength	
	Frequency [MHz]	Field strength [dB μ V/m] @ 3 m
T_{nom} / V_{nom}	2480	90.66
Measurement uncertainty	± 3 dB	

Result: passed.

9.2 Occupied bandwidth (99% bandwidth)

Description:

Measurement of the 99% bandwidth of the wanted signal.

Measurement:

Measurement parameter	
Detector:	Peak
Sweep time:	Auto
Video bandwidth:	50 kHz
Resolution bandwidth:	100 kHz
Span:	8 MHz
Trace-Mode:	Max Hold

Results:Lowest channel:

Test condition	Occupied bandwidth	
	Frequency [MHz]	Occupied bandwidth [kHz]
T_{nom} / V_{nom}	2402	1019
Measurement uncertainty	± 3 dB	

Middle channel

Test condition	Occupied bandwidth	
	Frequency [MHz]	Occupied bandwidth [kHz]
T_{nom} / V_{nom}	2442	1009
Measurement uncertainty	± 3 dB	

Highest channel

Test condition	Occupied bandwidth	
	Frequency [MHz]	Occupied bandwidth [kHz]
T_{nom} / V_{nom}	2480	1034
Measurement uncertainty	± 3 dB	

Result: passed.

Plot 1: lowest channel

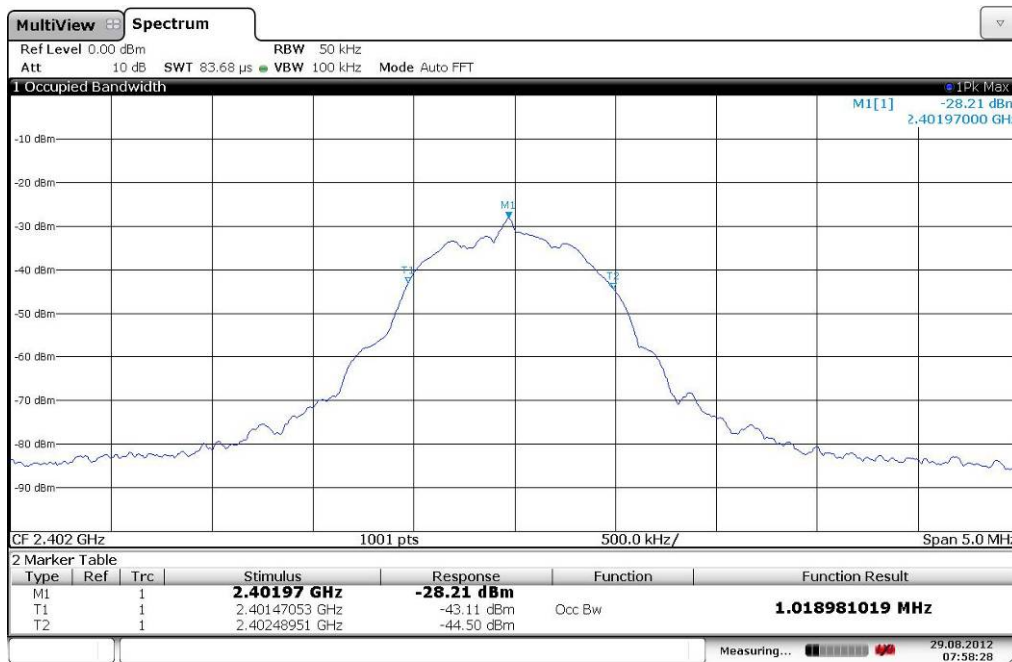

Plot 2: middle channel

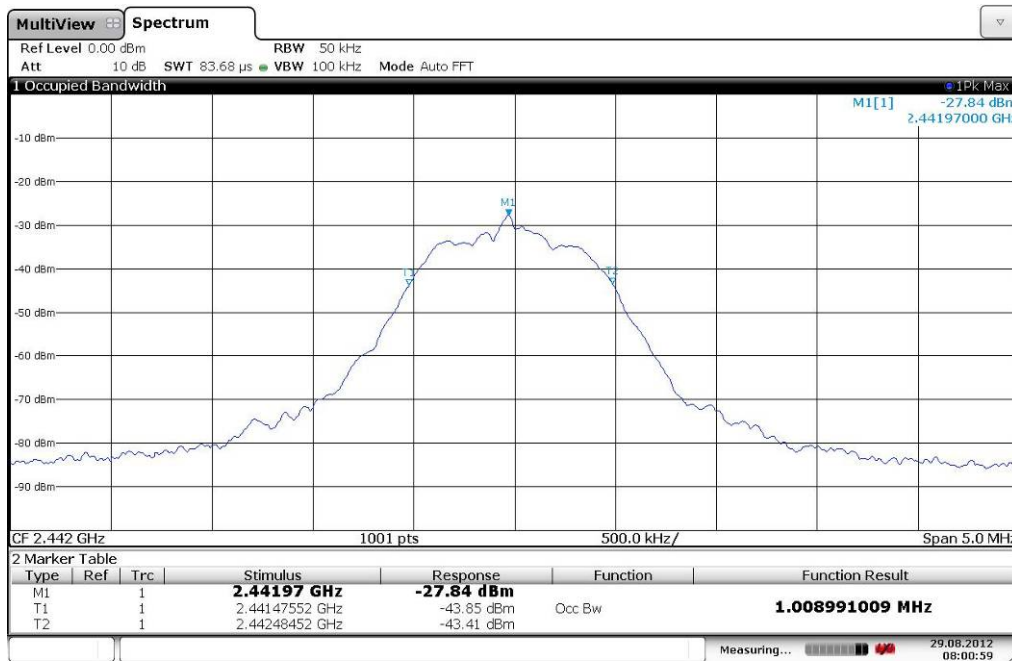

Plot 3: highest channel



9.3 Field strength of emissions (radiated spurious)

Description:

Measurement of the radiated spurious emissions in transmit mode.

Measurement:

Measurement parameter	
Detector:	Peak / Quasi Peak
Sweep time:	Auto
Video bandwidth:	Auto
Resolution bandwidth:	F < 1 GHz: 100 kHz F > 1 GHz: 1 MHz
Frequency range:	30 MHz to 100 GHz
Trace-Mode:	Max Hold

Limits:

FCC		
CFR Part 15.209(a)		
Radiated Spurious Emissions		
Emissions radiated outside of the specified frequency bands, except for harmonics, shall be attenuated by at least 50 dB below the level of the fundamental or to the general radiated emission limits in § 15.209, whichever is the lesser attenuation.		
Frequency (MHz)	Field Strength (dBµV/m)	Measurement distance
0.009 – 0.490	2400/F(kHz)	300
0.490 – 1.705	24000/F(kHz)	30
1.705 – 30.0	30	30
30 – 88	30.0	10
88 – 216	33.5	10
216 – 960	36.0	10
Above 960	54.0	3

Results:

TX Spurious Emissions Radiated [dB μ V/m]								
Lowest channel			Middle channel			Highest channel		
F [MHz]	Detector	Level [dB μ V/m]	F [MHz]	Detector	Level [dB μ V/m]	F [MHz]	Detector	Level [dB μ V/m]
No critical peaks found			No critical peaks found			No critical peaks found		
Measurement uncertainty			± 3 dB					

Result: passed.

Plot 1: Lowest channel; 30 MHz to 1 GHz, horizontal & vertical polarization

CETECOM ICT Services GmbH

Common Information

EUT: TST PDFSAS
 Serial Number:
 Test Description: FCC part 15 class B @ 10 m
 Operating Conditions: TX 2402 MHz
 Operator Name: Hennemann
 Comment: DC: 24 V

Scan Setup: STAN_Fin [EMI radiated]

Hardware Setup: Electric Field (NOS)
 Receiver: [ESC1 3]
 Level Unit: dBµV/m

Subrange	Step Size	Detectors	IF BW	Meas. Time	Preamp
30 MHz - 2 GHz	60 kHz	QPK	120 kHz	1 s	20 dB

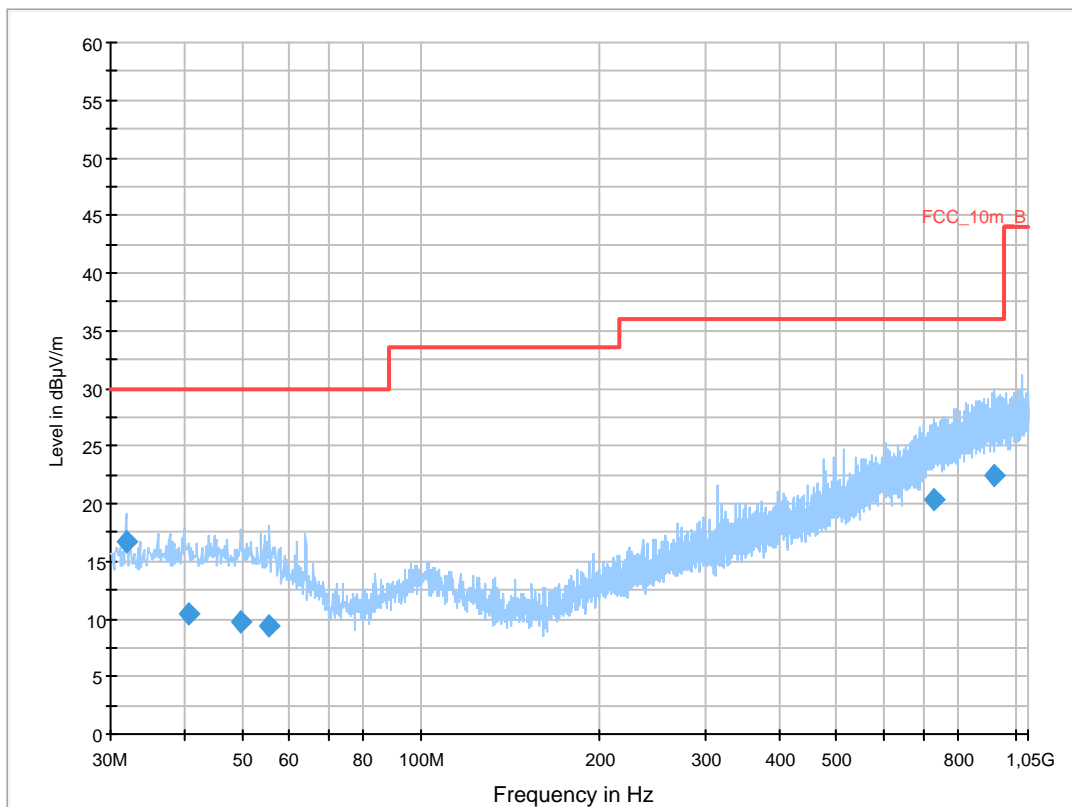

Final Result 1

Frequency (MHz)	QuasiPeak (dBµV/m)	Meas. Time (ms)	Bandwidth (kHz)	Height (cm)	Polarization	Azimuth (deg)	Corr. (dB)	Margin (dB)	Limit (dBµV/m)	Comment
31.989300	16.7	1000.0	120.000	121.0	V	-10.0	12.7	13.3	30.0	
40.532550	10.4	1000.0	120.000	170.0	H	0.0	13.4	19.6	30.0	
49.626150	9.8	1000.0	120.000	105.0	V	81.0	13.4	20.2	30.0	
55.582800	9.4	1000.0	120.000	120.0	H	272.0	12.7	20.6	30.0	
730.339800	20.3	1000.0	120.000	170.0	V	100.0	23.2	15.7	36.0	
923.228850	22.4	1000.0	120.000	170.0	H	-10.0	25.3	13.6	36.0	

Hardware Setup: EMI radiated\Electric Field (NOS) - [EMI radiated]

Subrange 1

Frequency Range:	30 MHz - 2 GHz
Receiver:	Receiver [ESCI 3] @ GPIB0 (ADR 20), SN 100083/003, FW 4.42
Signal Path:	without Notch FW 1.0
Antenna:	VULB 9163 SN 9163-295, FW --- Correction Table (vertical): VULP6113 Correction Table (horizontal): VULP6113 Correction Table (vertical): Cable_EN_1GHz (1005) Correction Table (horizontal): Cable_EN_1GHz (1005)
Antenna Tower:	Tower [EMCO 2090 Antenna Tower] @ GPIB0 (ADR 8), FW REV 3.12
Turntable:	Turntable [EMCO Turntable] @ GPIB0 (ADR 9), FW REV 3.12

EMC 32 Version 8.52

Plot 2: Lowest channel; 1 GHz to 4 GHz, horizontal & vertical polarization

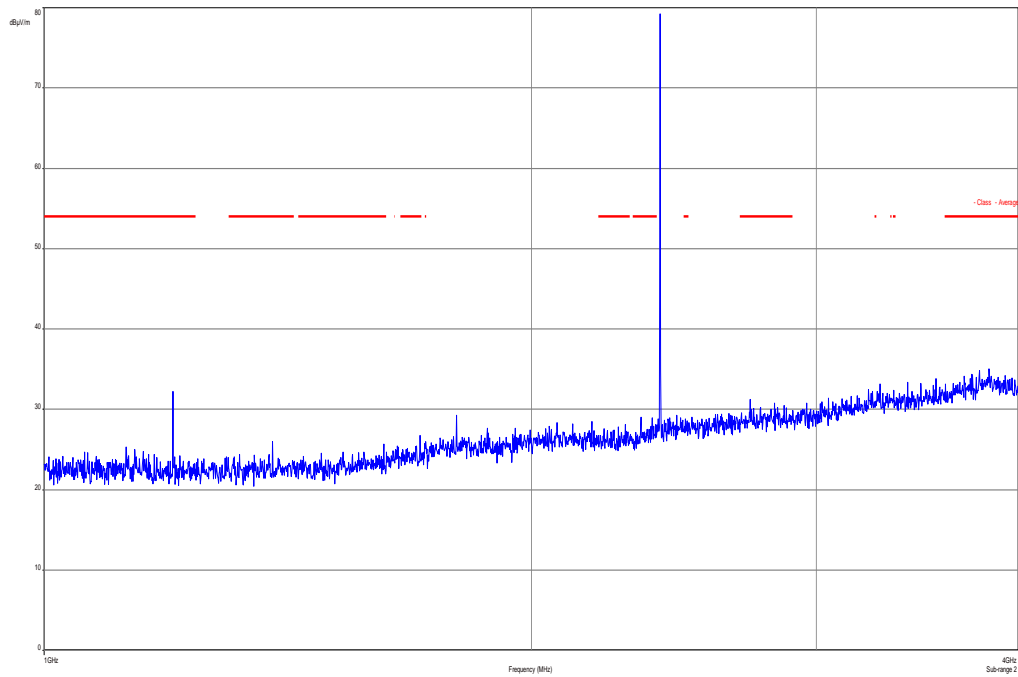

Plot 3: Lowest channel; Band-Edge-Compliance

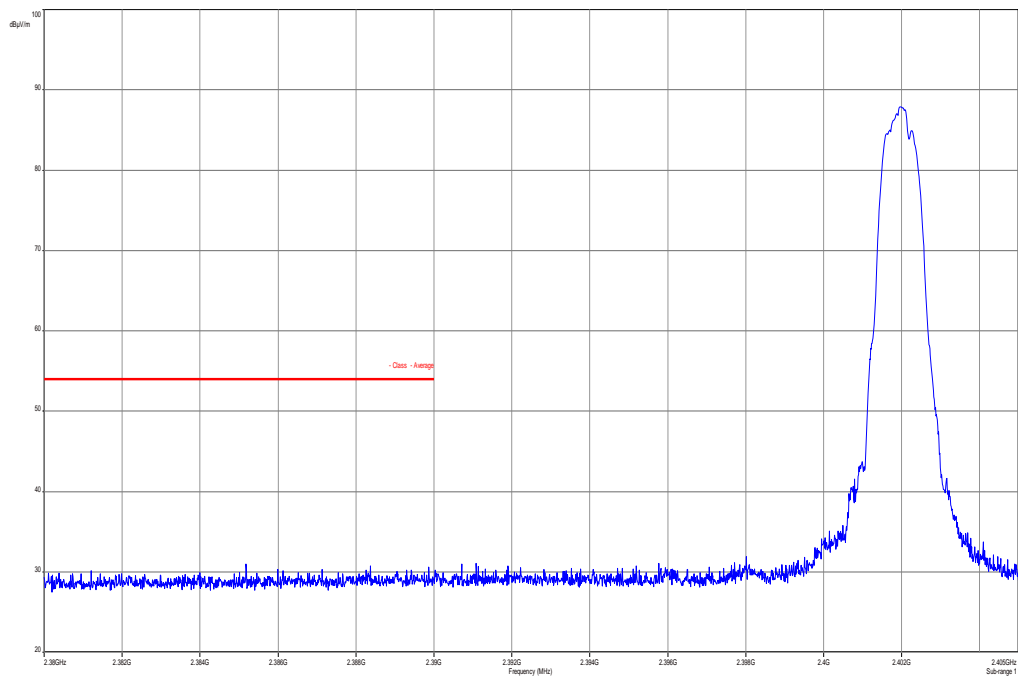

Plot 4: Lowest channel; 4 GHz to 12.75 GHz, horizontal & vertical polarization

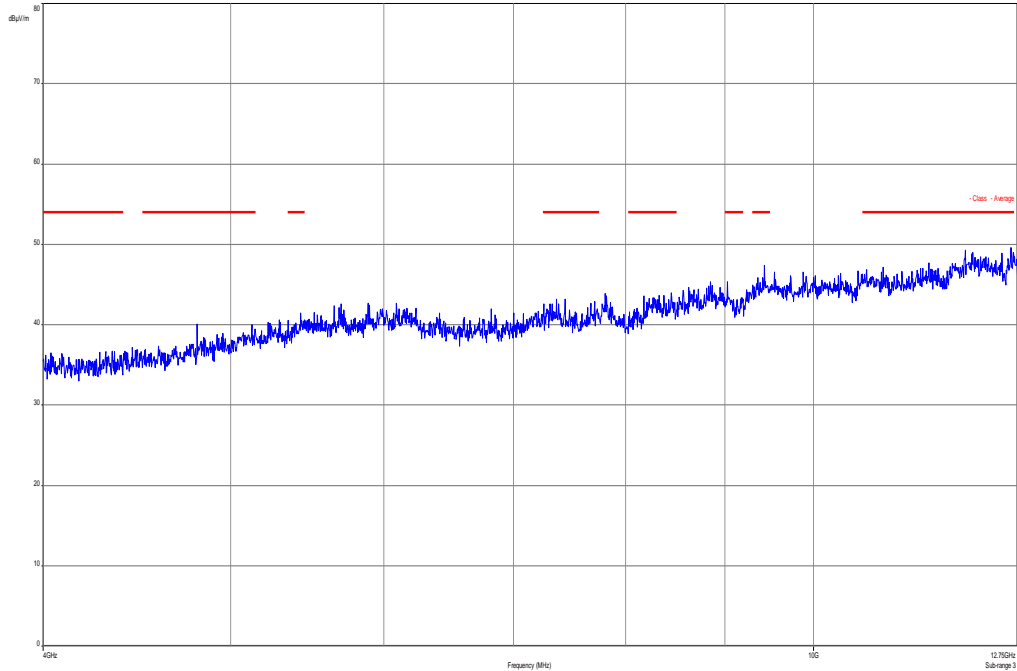

Plot 5: Lowest channel; 12.75 GHz to 18 GHz, horizontal & vertical polarization



Plot 6: Lowest channel; 18 GHz to 26 GHz, horizontal & vertical polarization

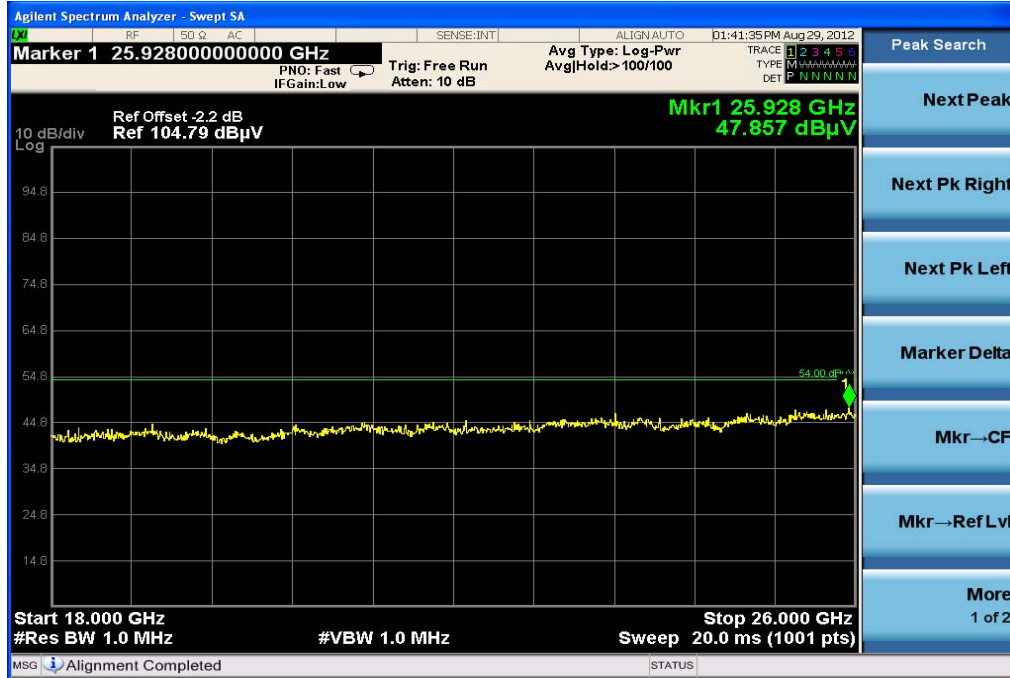

Plot 7: Middle channel; 9 kHz to 30 MHz

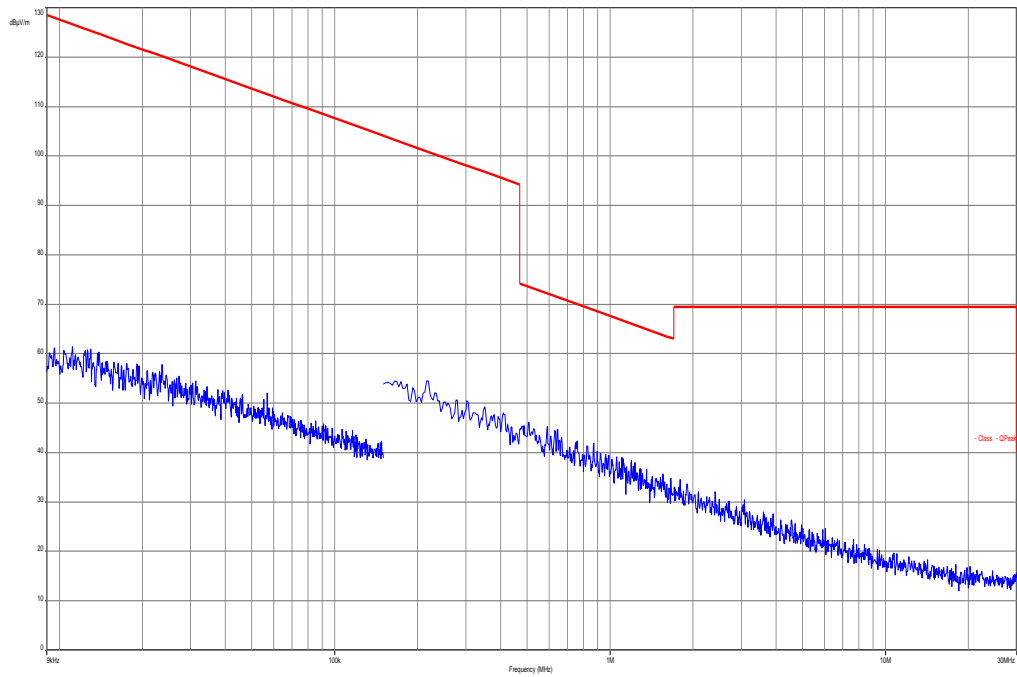

Plot 8: Middle channel; 30 MHz to 1 GHz, horizontal & vertical polarization

CETECOM ICT Services GmbH

Common Information

EUT: TST PDFSAS
 Serial Number:
 Test Description: FCC part 15 class B @ 10 m
 Operating Conditions: TX 2442 MHz
 Operator Name: Hennemann
 Comment: DC: 24 V

Scan Setup: STAN_Fin [EMI radiated]

Hardware Setup: Electric Field (NOS)
 Receiver: [ESC1 3]
 Level Unit: dBµV/m

Subrange	Step Size	Detectors	IF BW	Meas. Time	Preamp
30 MHz - 2 GHz	60 kHz	QPK	120 kHz	1 s	20 dB

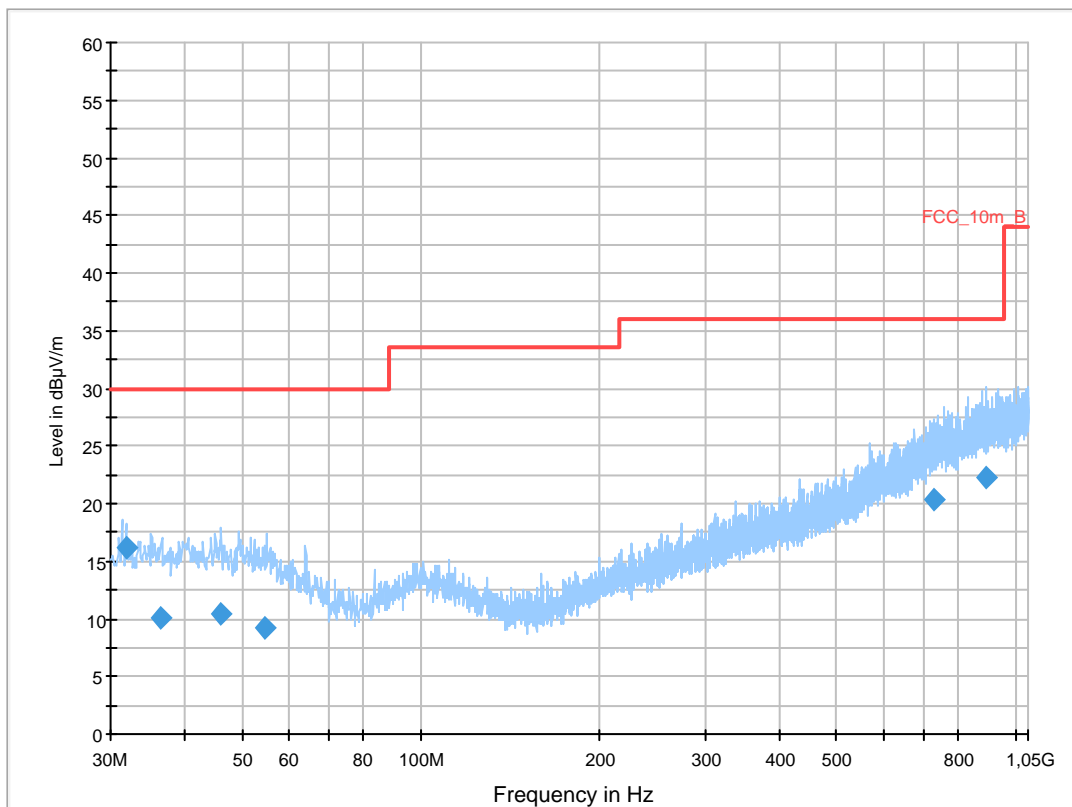

Final Result 1

Frequency (MHz)	QuasiPeak (dBµV/m)	Meas. Time (ms)	Bandwidth (kHz)	Height (cm)	Polarization	Azimuth (deg)	Corr. (dB)	Margin (dB)	Limit (dBµV/m)	Comment
31.986750	16.2	1000.0	120.000	170.0	V	182.0	12.7	13.8	30.0	
36.490200	10.1	1000.0	120.000	170.0	V	-5.0	13.2	19.9	30.0	
45.969600	10.4	1000.0	120.000	131.0	H	182.0	13.3	19.6	30.0	
54.547800	9.1	1000.0	120.000	120.0	V	-4.0	12.9	20.9	30.0	
728.013450	20.3	1000.0	120.000	170.0	H	190.0	23.2	15.7	36.0	
895.300650	22.3	1000.0	120.000	105.0	V	-2.0	25.1	13.7	36.0	

Hardware Setup: EMI radiated\Electric Field (NOS) - [EMI radiated]

Subrange 1

Frequency Range:	30 MHz - 2 GHz
Receiver:	Receiver [ESCI 3] @ GPIB0 (ADR 20), SN 100083/003, FW 4.42
Signal Path:	without Notch FW 1.0
Antenna:	VULB 9163 SN 9163-295, FW --- Correction Table (vertical): VULP6113 Correction Table (horizontal): VULP6113 Correction Table (vertical): Cable_EN_1GHz (1005) Correction Table (horizontal): Cable_EN_1GHz (1005)
Antenna Tower:	Tower [EMCO 2090 Antenna Tower] @ GPIB0 (ADR 8), FW REV 3.12
Turntable:	Turntable [EMCO Turntable] @ GPIB0 (ADR 9), FW REV 3.12

EMC 32 Version 8.52

Plot 9: Middle channel; 1 GHz to 4 GHz, horizontal & vertical polarization

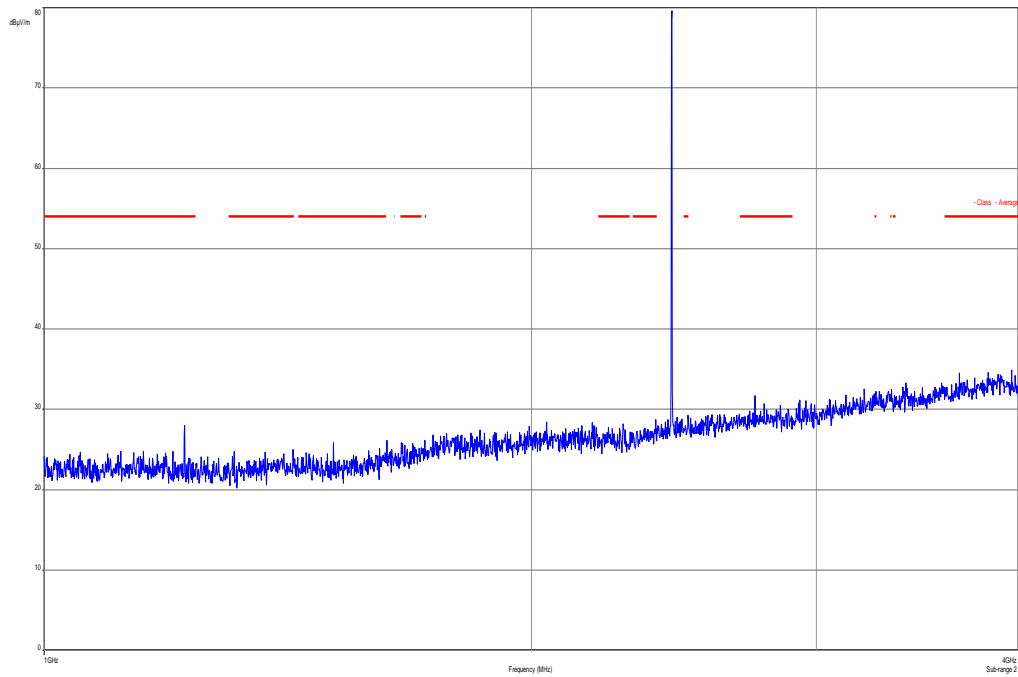

Plot 10: Middle channel; 4 GHz to 12.75 GHz, horizontal & vertical polarization

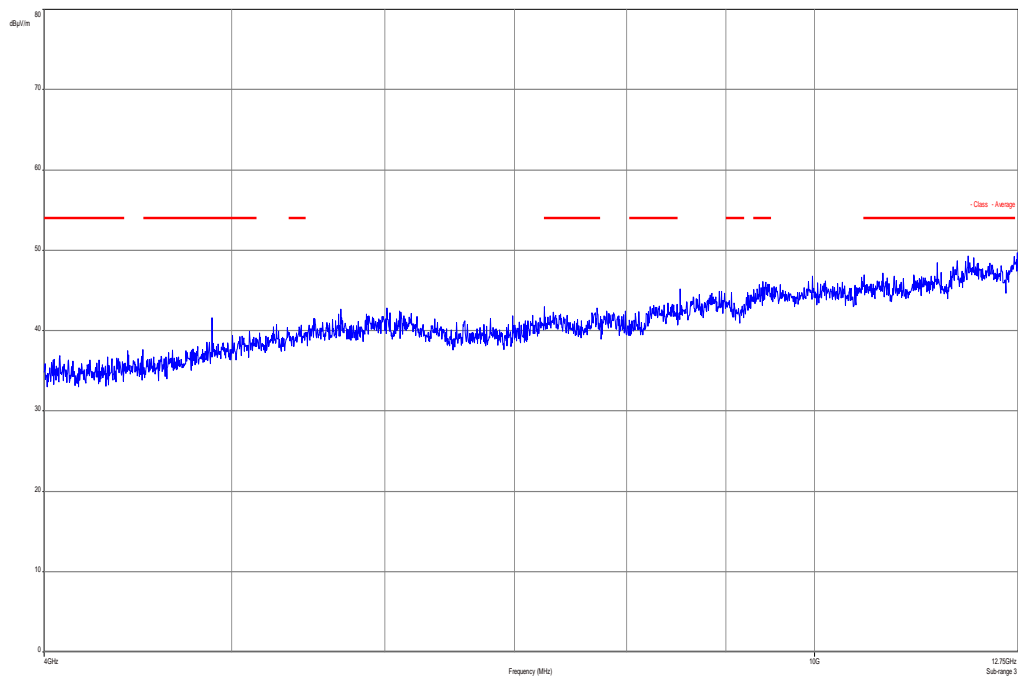

Plot 11: Middle channel; 12.75 GHz to 18 GHz, horizontal & vertical polarization



Plot 12: Middle channel; 18 GHz to 26 GHz, horizontal & vertical polarization

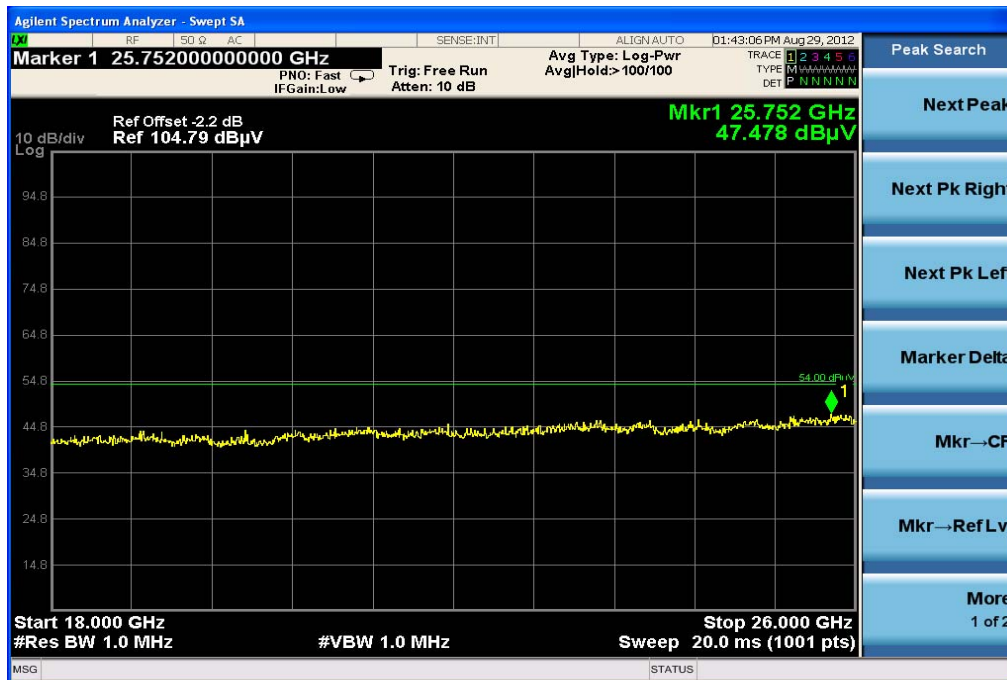

Plot 13: Highest channel; 30 MHz to 1 GHz, horizontal & vertical polarization

CETECOM ICT Services GmbH

Common Information

EUT: TST PDFSAS
 Serial Number:
 Test Description: FCC part 15 class B @ 10 m
 Operating Conditions: TX 2480 MHz
 Operator Name: Hennemann
 Comment: DC: 24 V

Scan Setup: STAN_Fin [EMI radiated]

Hardware Setup: Electric Field (NOS)
 Receiver: [ESC1 3]
 Level Unit: dBµV/m

Subrange	Step Size	Detectors	IF BW	Meas. Time	Preamp
30 MHz - 2 GHz	60 kHz	QPK	120 kHz	1 s	20 dB

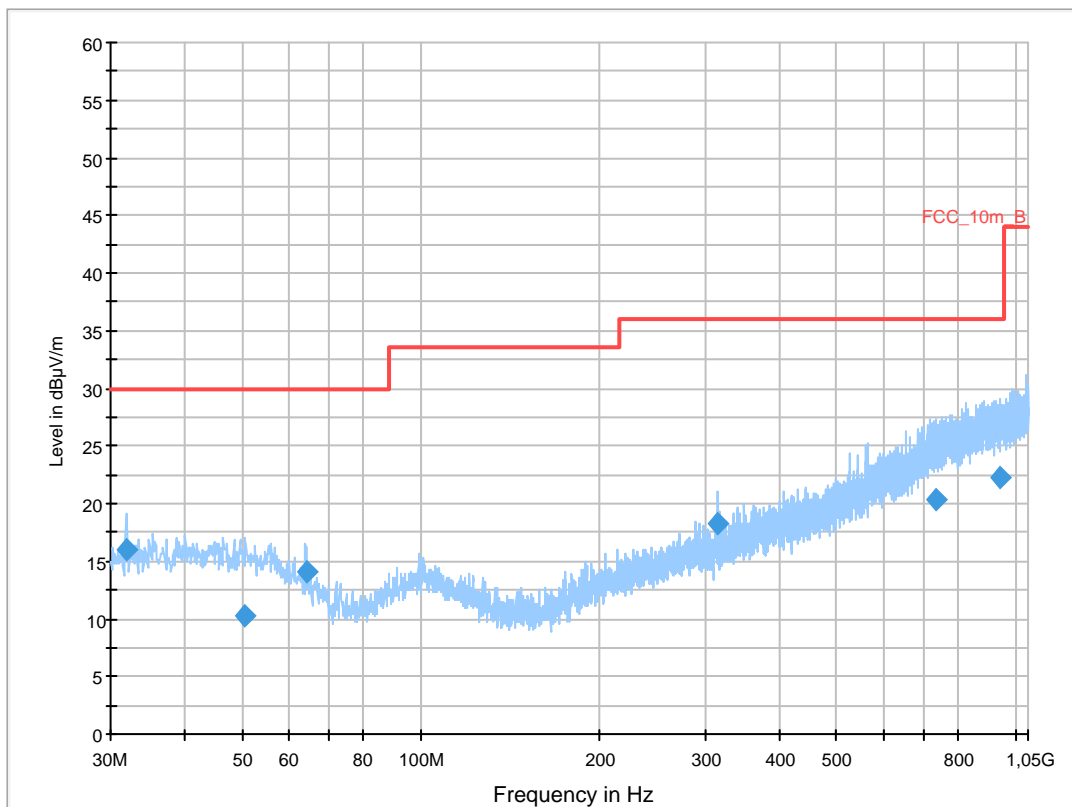

Final Result 1

Frequency (MHz)	QuasiPeak (dBµV/m)	Meas. Time (ms)	Bandwidth (kHz)	Height (cm)	Polarization	Azimuth (deg)	Corr. (dB)	Margin (dB)	Limit (dBµV/m)	Comment
32.014350	16.1	1000.0	120.000	170.0	V	81.0	12.7	13.9	30.0	
50.520000	10.2	1000.0	120.000	111.0	V	100.0	13.3	19.8	30.0	
64.021500	14.2	1000.0	120.000	161.0	V	270.0	10.6	15.8	30.0	
314.990550	18.3	1000.0	120.000	98.0	V	170.0	15.0	17.7	36.0	
734.858100	20.3	1000.0	120.000	120.0	V	175.0	23.3	15.7	36.0	
941.100450	22.3	1000.0	120.000	98.0	V	273.0	25.3	13.7	36.0	

Hardware Setup: EMI radiated\Electric Field (NOS) - [EMI radiated]

Subrange 1

Frequency Range:	30 MHz - 2 GHz
Receiver:	Receiver [ESCI 3] @ GPIB0 (ADR 20), SN 100083/003, FW 4.42
Signal Path:	without Notch FW 1.0
Antenna:	VULB 9163 SN 9163-295, FW --- Correction Table (vertical): VULP6113 Correction Table (horizontal): VULP6113 Correction Table (vertical): Cable_EN_1GHz (1005) Correction Table (horizontal): Cable_EN_1GHz (1005)
Antenna Tower:	Tower [EMCO 2090 Antenna Tower] @ GPIB0 (ADR 8), FW REV 3.12
Turntable:	Turntable [EMCO Turntable] @ GPIB0 (ADR 9), FW REV 3.12

EMC 32 Version 8.52

Plot 14: Highest channel; 1 GHz to 4 GHz, horizontal & vertical polarization

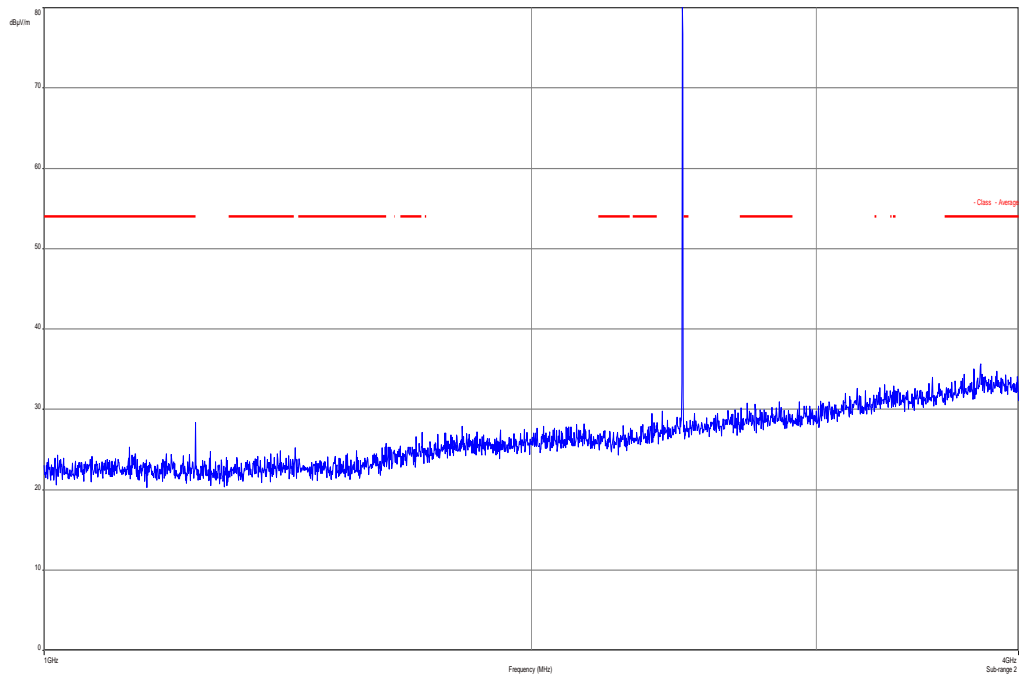

Plot 15: Highest channel; Band-Edge-Compliance

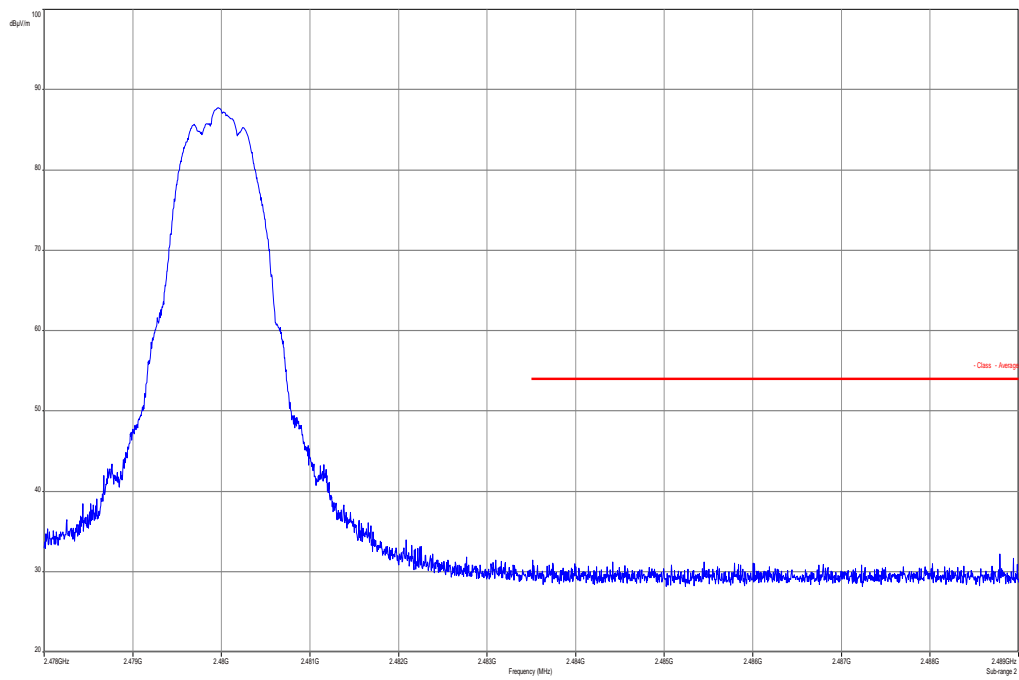

Plot 16: Highest channel; 4 GHz to 12.75 GHz, horizontal & vertical polarization

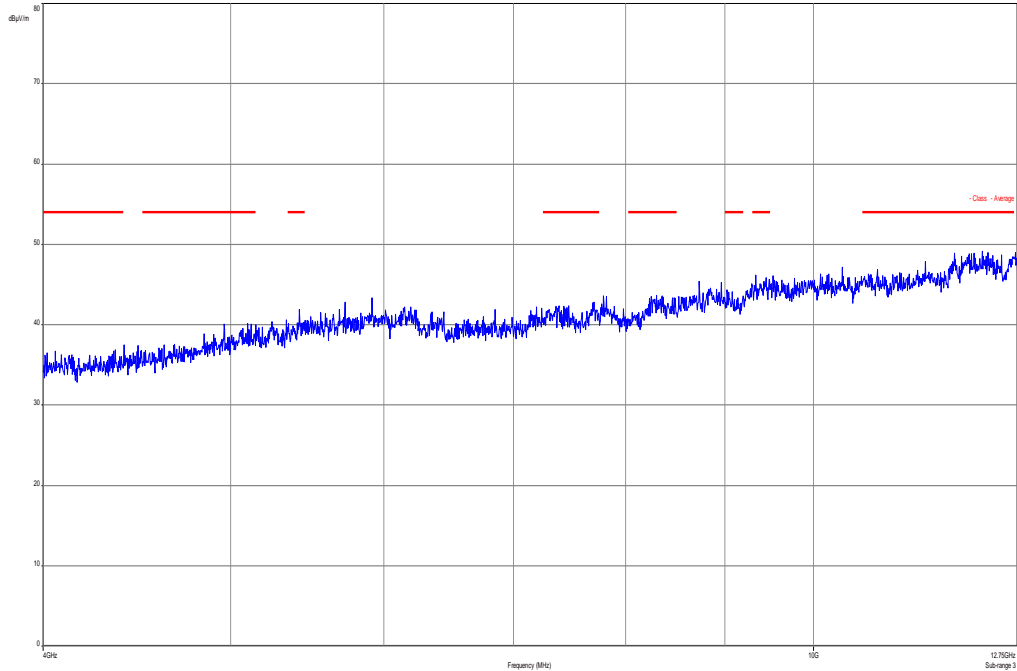

Plot 17: Highest channel; 12.75 GHz to 18 GHz, horizontal & vertical polarization

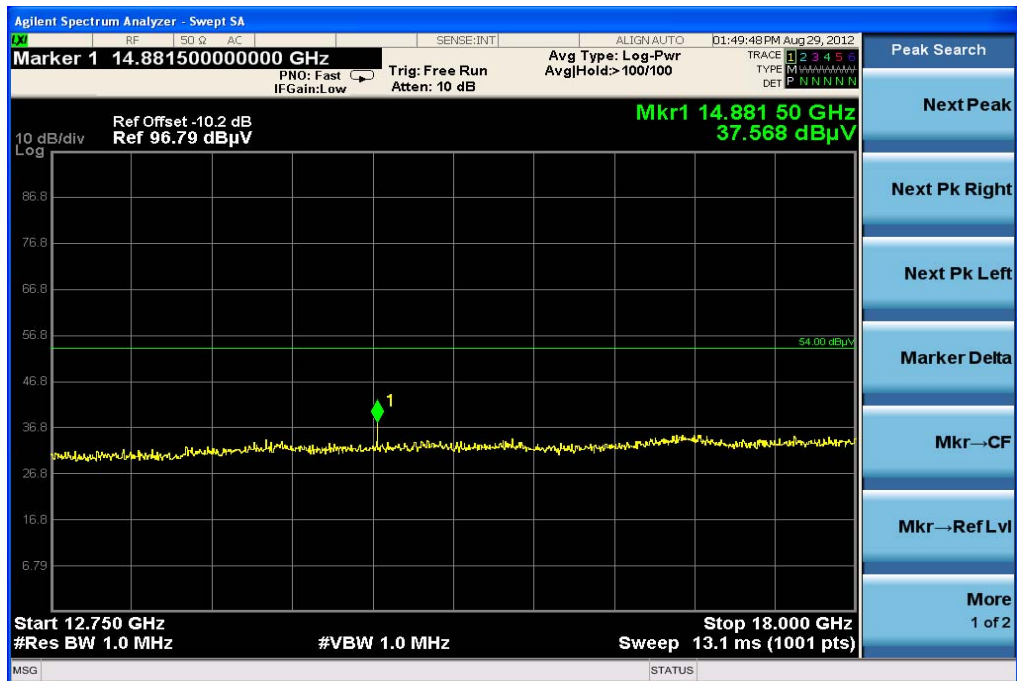

Plot 18: Highest channel; 18 GHz to 26 GHz, horizontal & vertical polarization



9.4 Conducted spurious emissions < 30 MHz

Description:

Measurement of the conducted spurious emissions in transmit mode below 30 MHz. Both power lines, phase and neutral line, are measured. Found peaks are re-measured with average and quasi peak detection to show compliance to the limits.

Measurement:

Measurement parameter	
Detector:	Peak - Quasi Peak / Average
Sweep time:	Auto
Video bandwidth:	F < 150 kHz: 200 Hz F > 150 kHz: 9 kHz
Resolution bandwidth:	F < 150 kHz: 1 kHz F > 150 kHz: 100 kHz
Span:	9 kHz to 30 MHz
Trace-Mode:	Max Hold

Limits:

FCC		
CFR Part 15.207(a)		
Conducted Spurious Emissions < 30 MHz		
Frequency (MHz)	Quasi-Peak (dBµV/m)	Average (dBµV/m)
0.15 – 0.5	66 to 56*	56 to 46*
0.5 – 5	56	46
5 – 30.0	60	50

*Decreases with the logarithm of the frequency

Results:

Conducted Spurious Emissions < 30 MHz [dBµV/m]		
F [MHz]	Detector	Level [dBµV/m]
No critical peaks found		
Measurement uncertainty	± 3 dB	

Result: passed.

Plot 1: Phase line

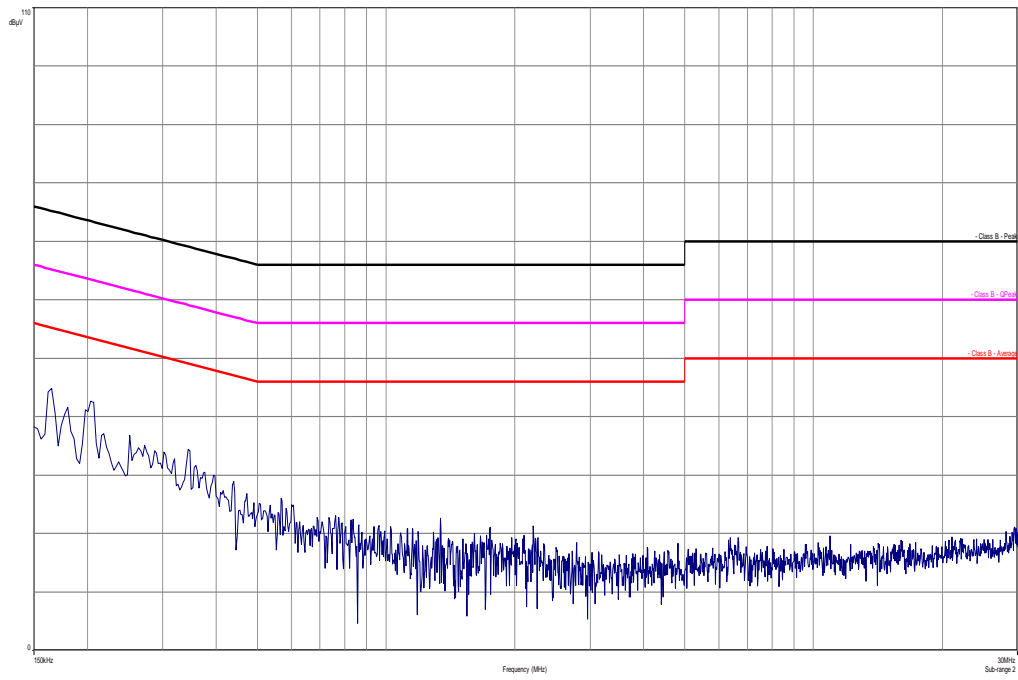

Plot 2: Neutral line

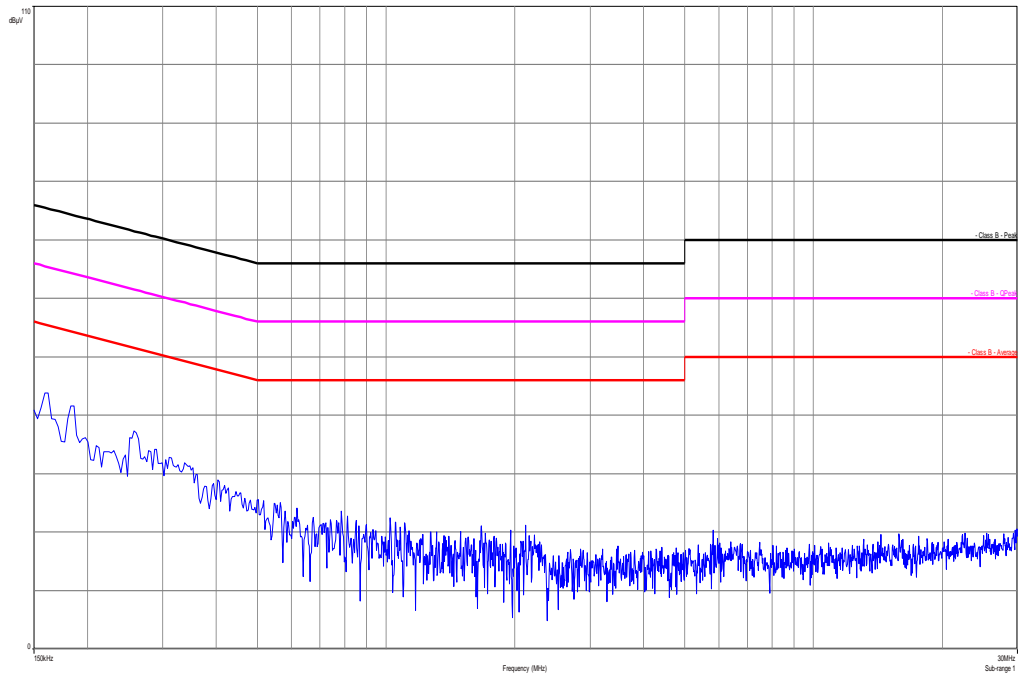

9.1 Results receiver mode

9.1.1 Spurious emissions radiated – receiver mode

Description:

The measurement was performed in worst case.

Measurement:

Measurement parameters	
Detector:	Below 1 GHz Peak / QuasiPeak Above 1 GHz Peak / Average
Sweep time:	2 sec
Video bandwidth:	Below 1 GHz 100 kHz Above 1 GHz 1 MHz
Resolution bandwidth:	1 MHz
Span:	100 MHz Steps
Trace-Mode:	Max Hold

Limits:

FCC		IC	
CFR Part 15.109 CFR Part 2.1053		RSS Gen, Issue 2, Section 4.10	
Spurious Emissions Radiated – Receiver Mode			
Frequency (MHz)	Field Strength (dB μ V/m)	Measurement distance (m)	
30 – 88	30.0	10	
88 - 216	33.5	10	
216 – 960	36.0	10	
Above 960	54.0	3	

Results:

SPURIOUS EMISSION LEVEL (DB μ V/M)		
Frequency (MHz)	Detector	Level (dB μ V/m)
No critical peaks found		
Measurement uncertainty		± 3dB

Result: Passed

Plots:

Plot 1: Receiver mode, 9 kHz – 30 MHz

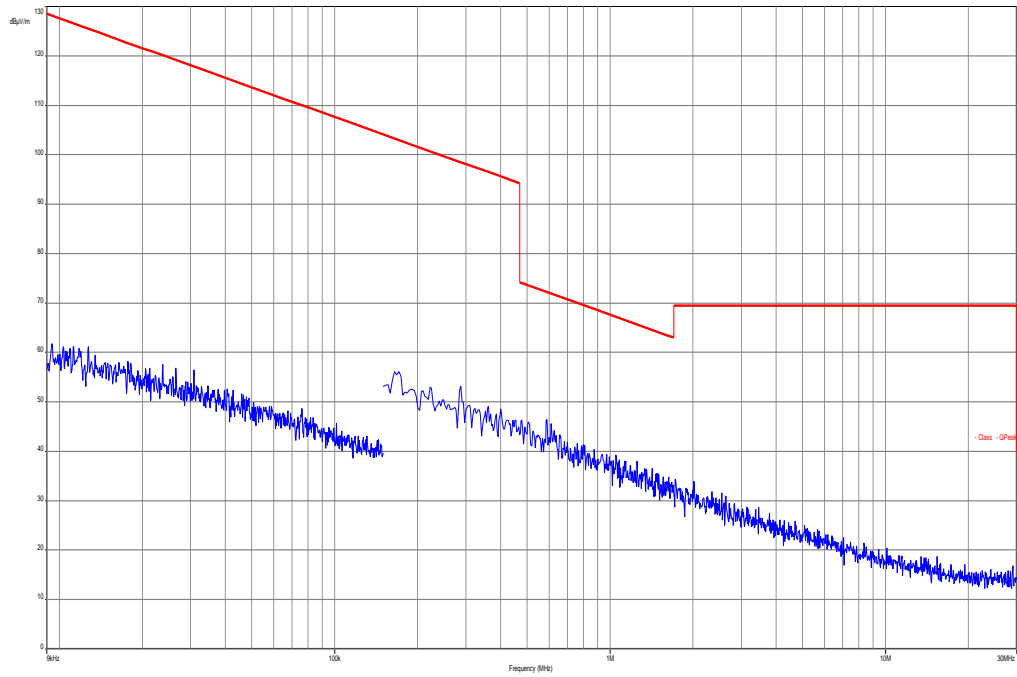

Plot 2: Receiver mode, 30 MHz - 1 GHz, horizontal & vertical polarisation

CETECOM ICT Services GmbH

Common Information

EUT: TST PDFSAS
 Serial Number:
 Test Description: FCC part 15 class B @ 10 m
 Operating Conditions: RX 2442 MHz
 Operator Name: Hennemann
 Comment: DC: 24 V

Scan Setup: STAN_Fin [EMI radiated]

Hardware Setup: Electric Field (NOS)
 Receiver: [ESCI 3]
 Level Unit: dBµV/m

Subrange	Step Size	Detectors	IF BW	Meas. Time	Preamp
30 MHz - 2 GHz	60 kHz	QPK	120 kHz	1 s	20 dB

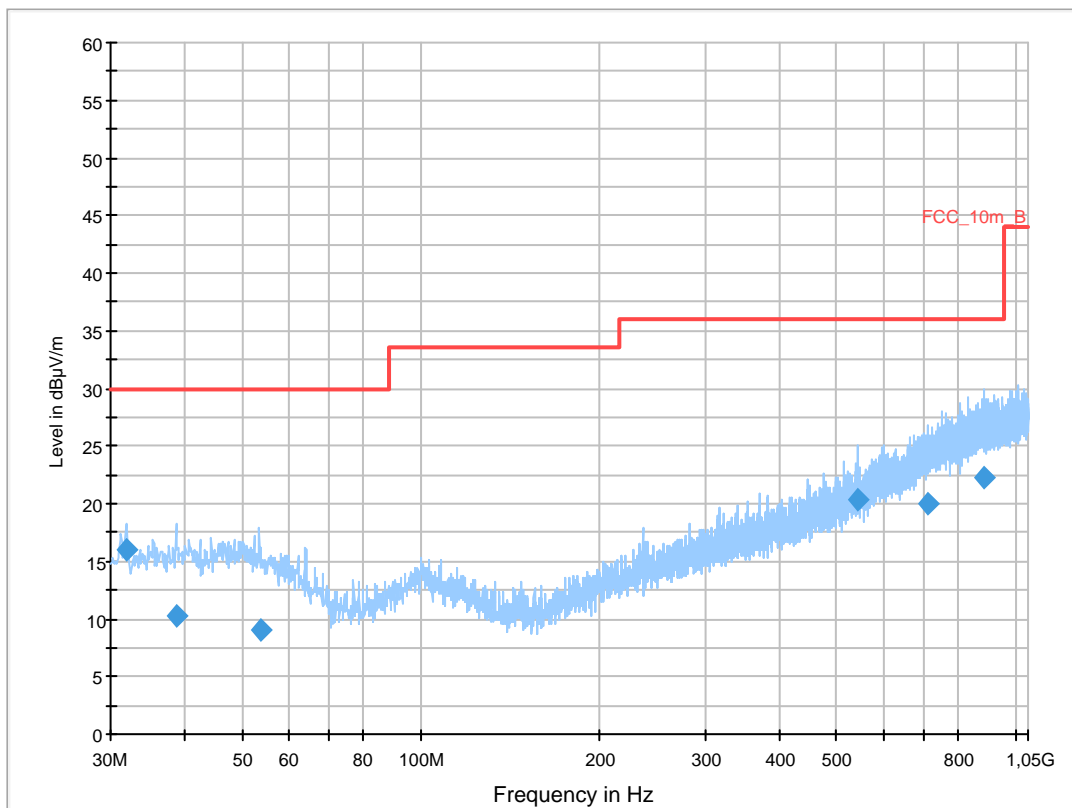

Final Result 1

Frequency (MHz)	QuasiPeak (dBµV/m)	Meas. Time (ms)	Bandwidth (kHz)	Height (cm)	Polarization	Azimuth (deg)	Corr. (dB)	Margin (dB)	Limit (dBµV/m)	Comment
31.983000	16.0	1000.0	120.000	152.0	V	10.0	12.7	14.0	30.0	
38.666250	10.3	1000.0	120.000	170.0	V	100.0	13.3	19.7	30.0	
53.521350	9.0	1000.0	120.000	105.0	V	92.0	13.0	21.0	30.0	
544.031400	20.4	1000.0	120.000	104.0	H	177.0	19.3	15.6	36.0	
714.860100	20.0	1000.0	120.000	120.0	V	272.0	22.9	16.0	36.0	
887.036850	22.2	1000.0	120.000	120.0	V	100.0	25.0	13.8	36.0	

Hardware Setup: EMI radiated\Electric Field (NOS) - [EMI radiated]

Subrange 1

Frequency Range: 30 MHz - 2 GHz

Receiver: Receiver [ESCI 3]
@ GPIB0 (ADR 20), SN 100083/003, FW 4.42

Signal Path: without Notch
FW 1.0

Antenna: VULB 9163
SN 9163-295, FW ---
Correction Table (vertical): VULP6113
Correction Table (horizontal): VULP6113
Correction Table (vertical): Cable_EN_1GHz (1005)
Correction Table (horizontal): Cable_EN_1GHz (1005)

Antenna Tower: Tower [EMCO 2090 Antenna Tower]
@ GPIB0 (ADR 8), FW REV 3.12

Turntable: Turntable [EMCO Turntable]
@ GPIB0 (ADR 9), FW REV 3.12

EMC 32 Version 8.52

Plot 3: Receiver mode, 1 GHz – 4 GHz, horizontal & vertical polarisation

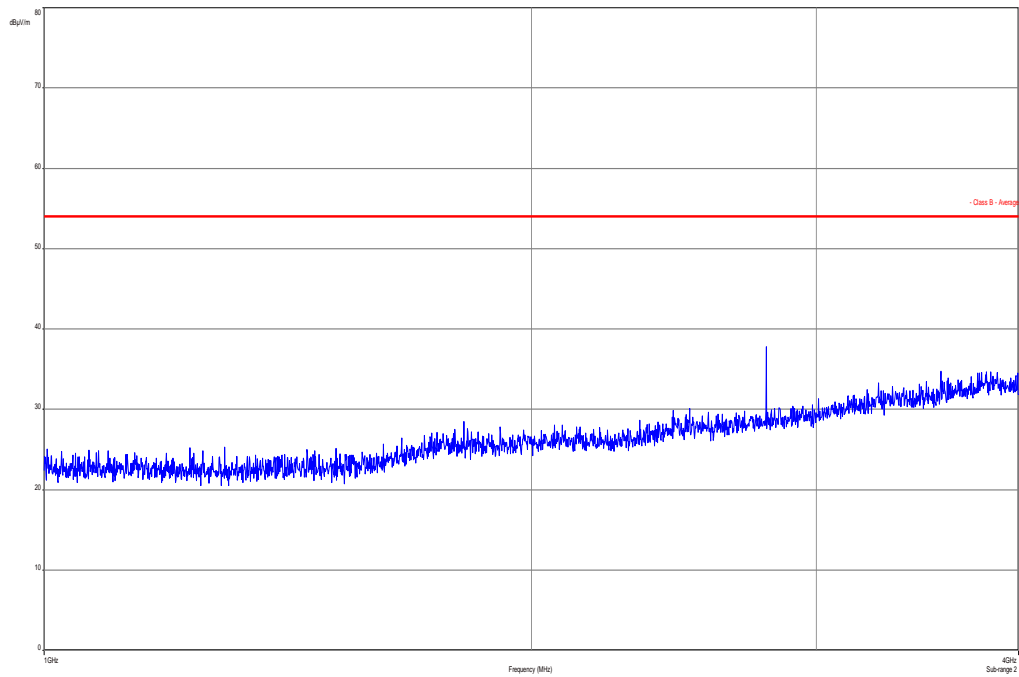

Plot 4: Receiver mode, 4 GHz – 12.75 GHz, horizontal & vertical polarisation

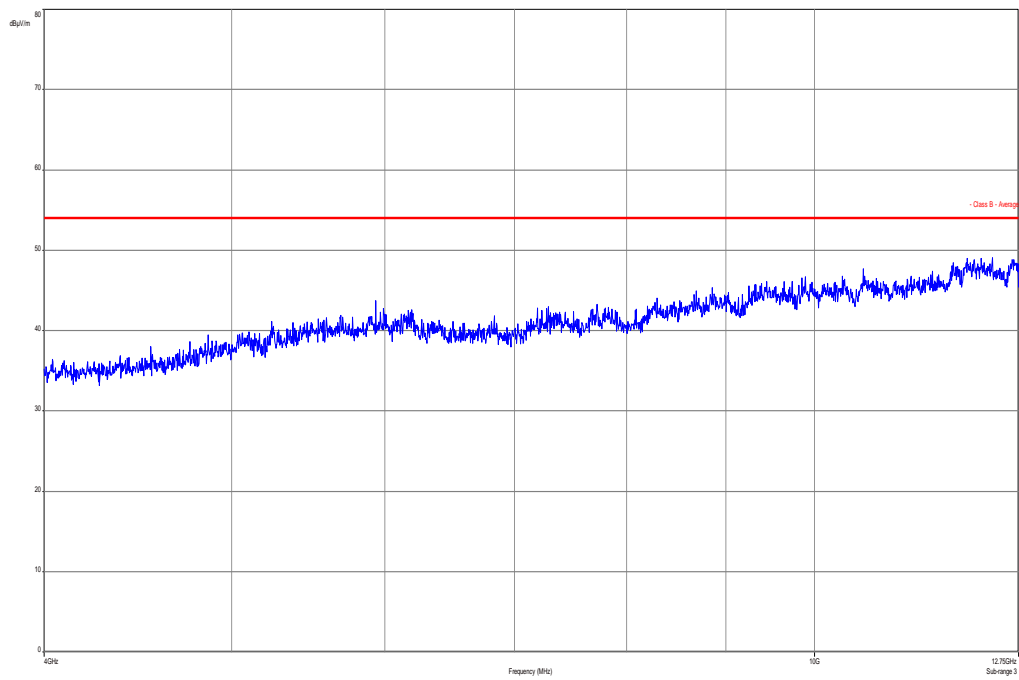

Plot 5: Receiver mode; 12.75 GHz to 18 GHz, horizontal & vertical polarization

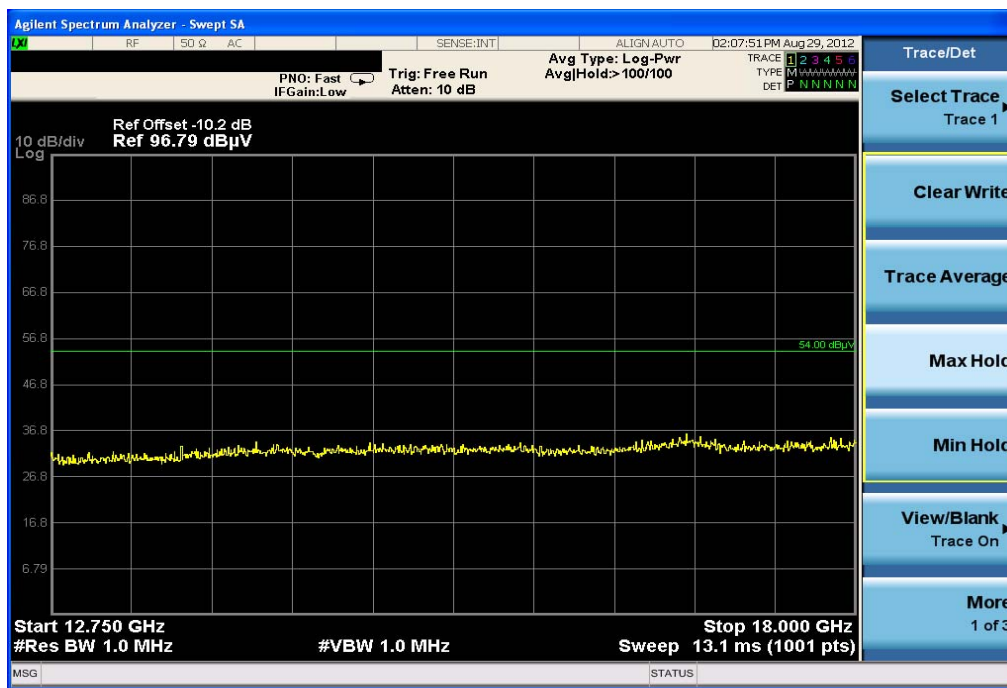

Plot 6: Receiver mode; 18 GHz to 26 GHz, horizontal & vertical polarization

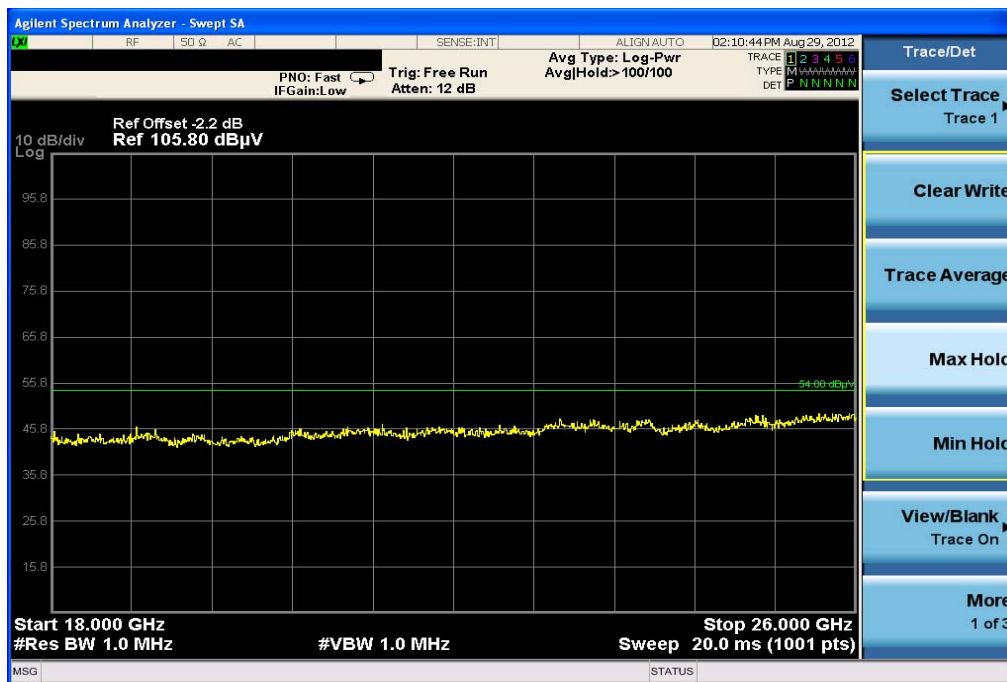

10 Test equipment and ancillaries used for tests

Typically, the calibrations of the test apparatus are commissioned to and performed by an accredited calibration laboratory. The calibration intervals are determined in accordance with the DIN EN ISO/IEC 17025. In addition to the external calibrations, the laboratory executes comparison measurements with other calibrated test systems or effective verifications. Weekly chamber inspections and range calibrations are performed. Where possible, rf-generating and signalling equipment as well as measuring receivers and analyzers are connected to an external high-precision 10 MHz reference (GPS-based or rubidium frequency standard).

In order to simplify the identification of the equipment used at some special tests, some items of test equipment and ancillaries can be provided with an identifier or number in the equipment list below (Labor/Item).

No.	Lab / Item	Equipment	Type	Manufact.	Serial No.	INV. No Cetecom	Kind of Calibration	Last Calibration	Next Calibration
1	n. a.	Temperature Test Chamber	VT 4002	Heraeus Voetsch	521/83761	300002326	Ve	20.09.2011	20.09.2013
2	n. a.	MXA Signal Analyzer 20 Hz - 26.5 GHz	N9020A MXA Signal Analyzer	Agilent Vertr. Bad Hom	US46220229	300003805	vIKI!	08.09.2010	08.09.2012
3	n. a.	DC power supply, 60Vdc, 50A, 1200 W	6032A	HP Meßtechnik	2818A03450	300001040	Ve	12.01.2012	12.01.2015
4	n. a.	Active Loop Antenna	6502	EMCO	2210	300001015	ne		
5	n. a.	Anechoic chamber	FAC 3/5m	MWB / TDK	87400/02	300000996	ev		
6	Spec.A. 2_2e	System rack for EMI measurement solution	85900	HP I.V.	*	300000222	ne		
7	9	Artificial Mains 9 kHz to 30 MHz	ESH3-Z5	R&S	828576/020	300001210	Ve	06.01.2012	06.01.2014
8	n. a.	Relais Matrix	3488A	HP Meßtechnik	2719A15013	300001156	ne		
9	n. a.	Relais Matrix	PSU	R&S	890167/024	300001168	ne		
10	n. a.	Isolating Transformer	RT5A	Grundig	9242	300001263	ne		
11	n. a.	Three-Way Power Splitter, 50 Ohm	11850C	HP Meßtechnik		300000997	ne		
12	n. a.	Switch / Control Unit	3488A	HP	2605e08770	300001443	ne		
13	n. a.	Amplifier	js42-00502650-28-5a	Parzich GMBH	928979	300003143	ne		
14	n. a.	Band Reject filter	WRCG1855/1910-1835/1925-40/8SS	Wainwright	7	300003350	ev		
15	n. a.	Band Reject filter	WRCG2400/2483-2375/2505-50/10SS	Wainwright	11	300003351	ev		
16	n. a.	Highpass Filter	WHKX2.9/18G-12SS	Wainwright	1	300003492	ev		
17	n. a.	Highpass Filter	WHK1.1/15G-10SS	Wainwright	3	300003255	ev		
18	n. a.	Highpass Filter	WHKX7.0/18G-8SS	Wainwright	18	300003789	ne		
19	n. a.	TRILOG Broadband Test-Antenna 30 MHz - 3 GHz	VULB9163	Schwarzbeck	371	300003854	vIKI!	14.10.2011	14.10.2014
20	n. a.	MXE EMI Receiver 20 Hz bis 26,5 GHz	N9038A	Agilent Technologies	MY51210197	300004405	k	19.12.2011	19.12.2012
21	n. a.	DC Power Supply 0 – 32V	1108-32	Heiden	001802	300001383	Ve	23.06.2010	23.06.2013

Agenda: Kind of Calibration

k	calibration / calibrated	EK	limited calibration
ne	not required (k, ev, izw, zw not required)	zw	cyclical maintenance (external cyclical maintenance)
ev	periodic self verification	izw	internal cyclical maintenance
Ve	long-term stability recognized	g	blocked for accredited testing
vkI!	Attention: extended calibration interval		
NK!	Attention: not calibrated	*)	next calibration ordered / currently in progress

11 Observations

No observations exceeding those reported with the single test cases have been made.

Annex A Photographs of the test setup

Photo documentation:

Photo 1:

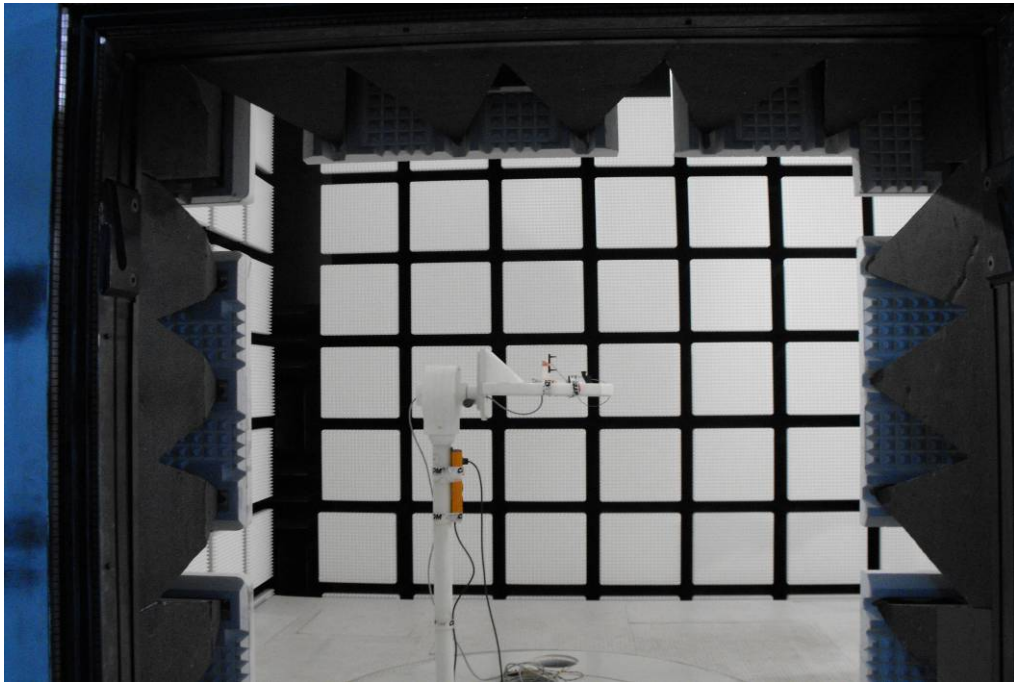

Photo 2:

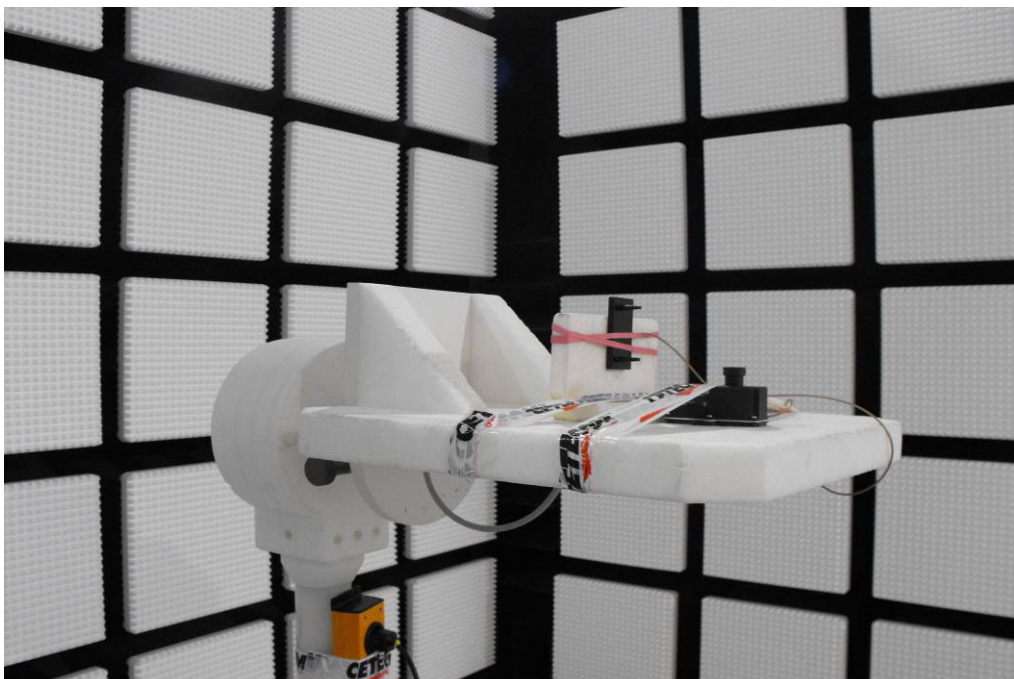

Photo 3:

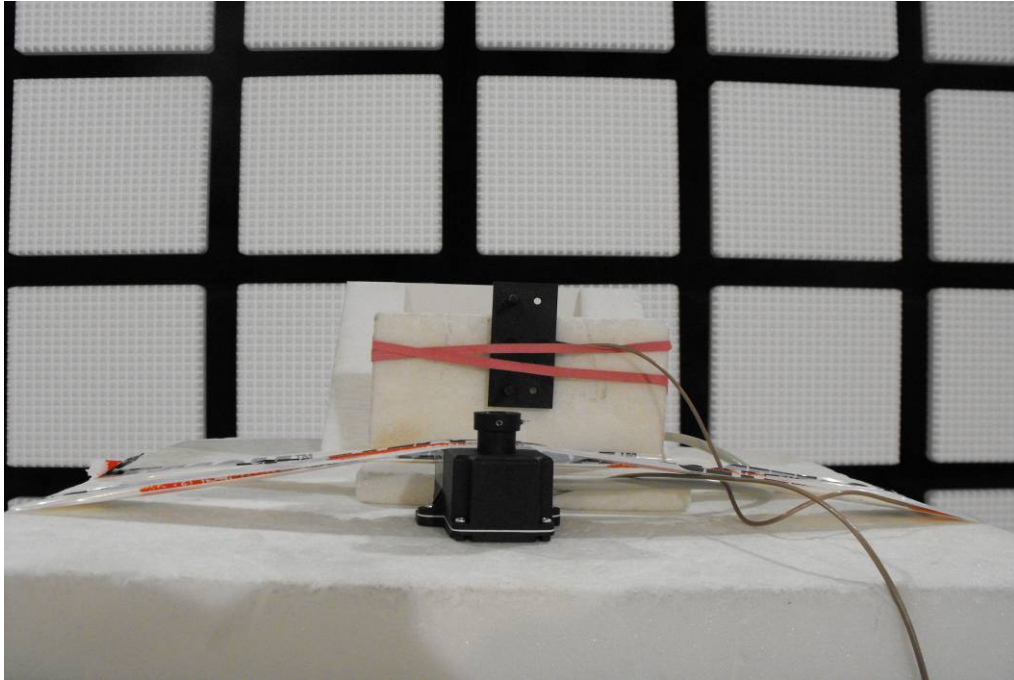

Photo 4:



Photo 5:



Photo 6:

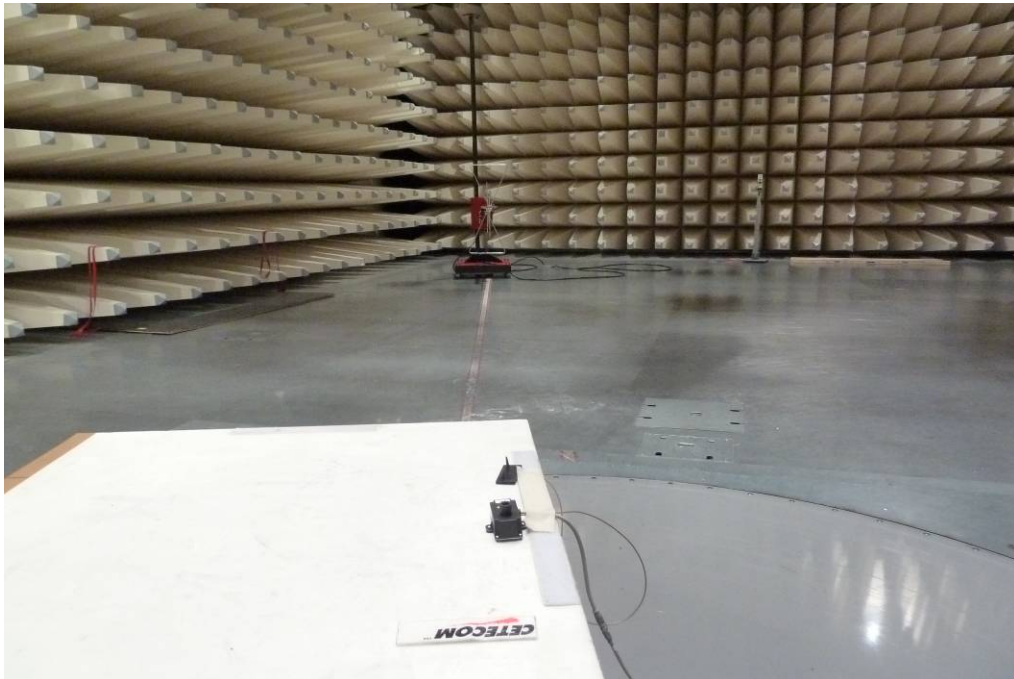

Photo 7:



Annex B External photographs of the EUT

Photo documentation:

Photo 1:

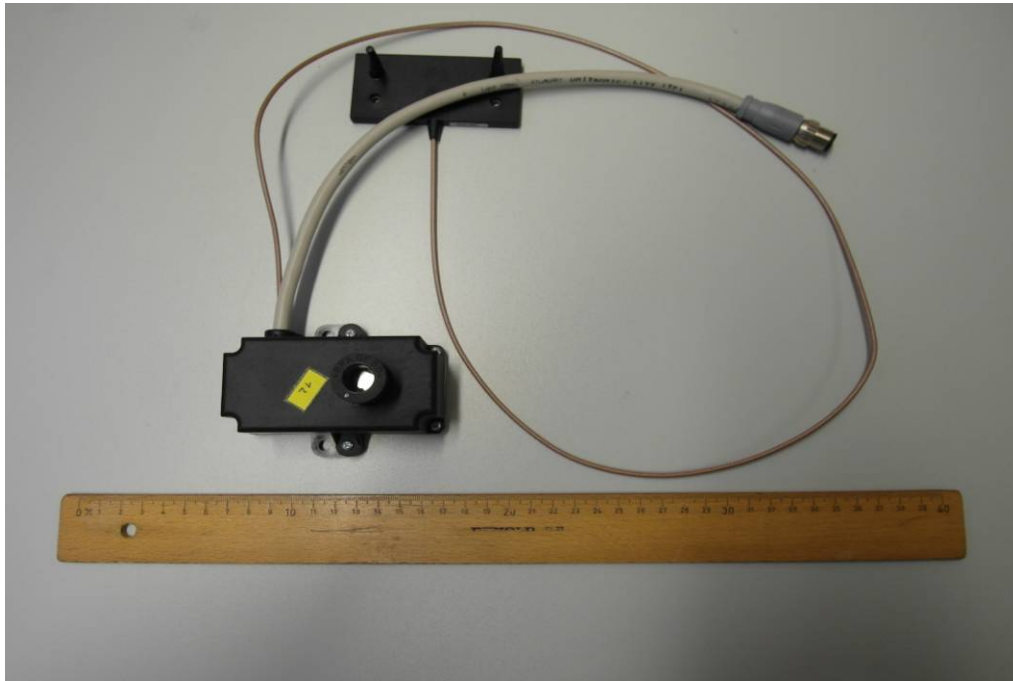

Photo 2:



Photo 3:



Photo 4:

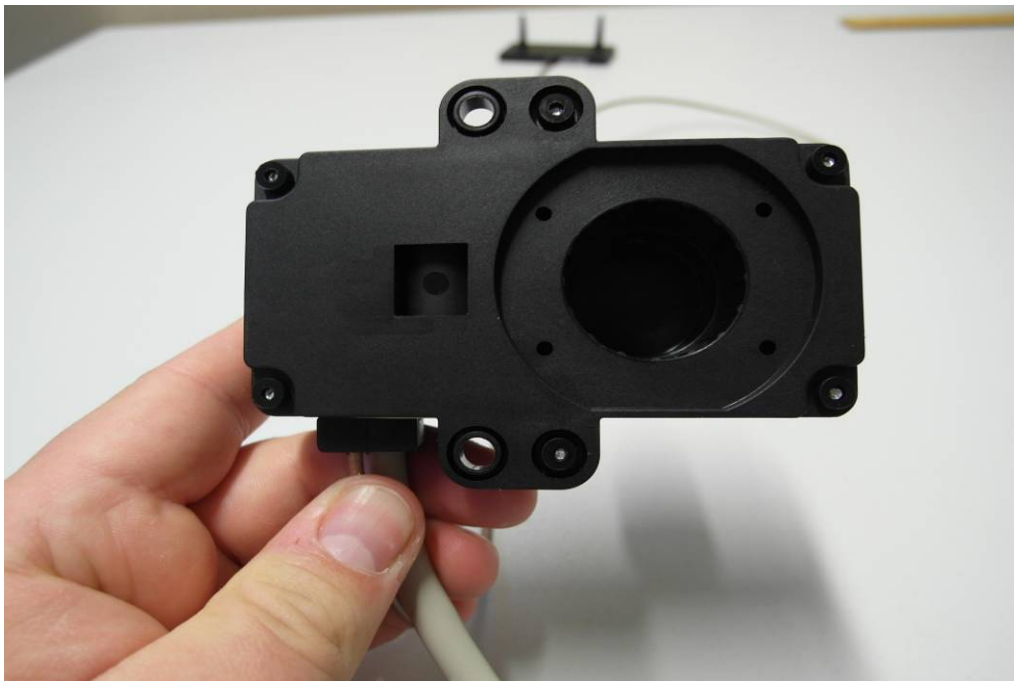

Photo 5:



Photo 6:



Photo 7:

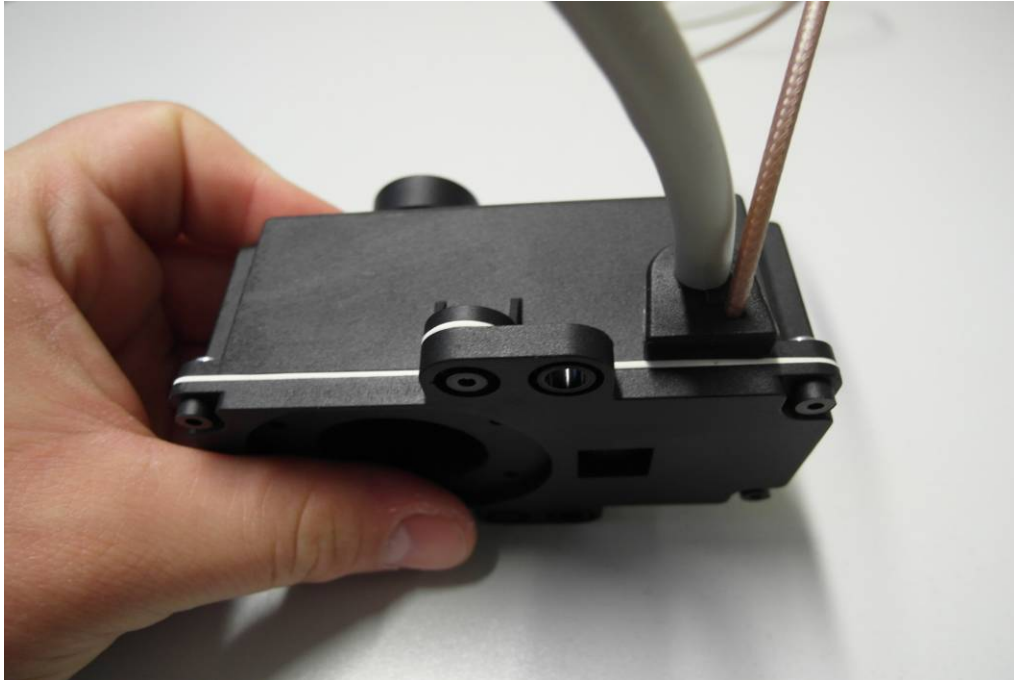

Photo 8:



Photo 9:



Photo 10:

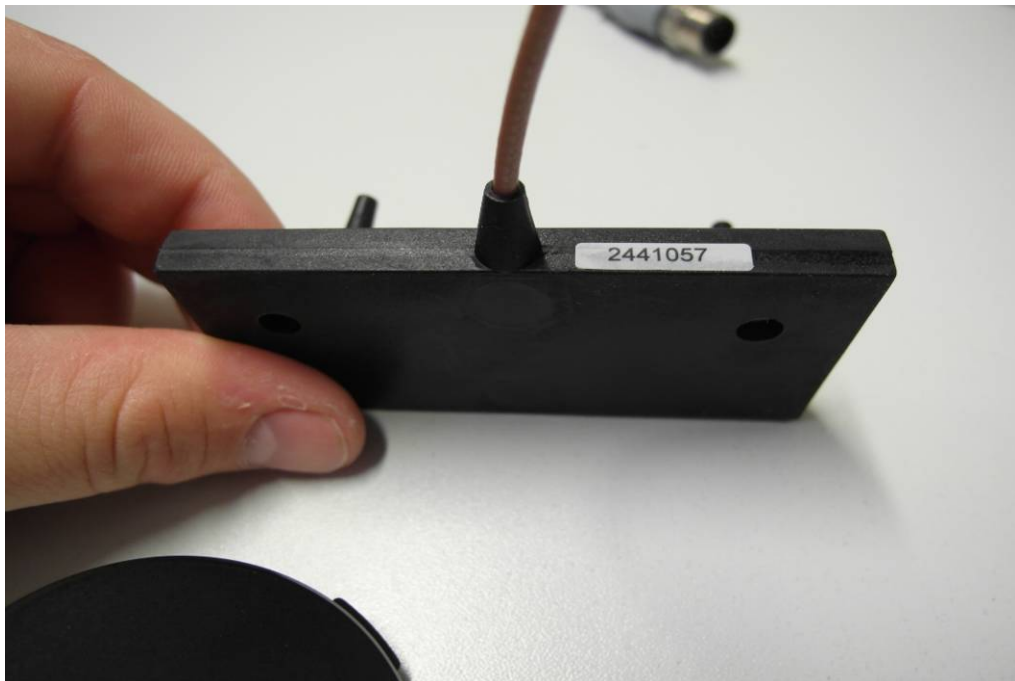

Photo 11:

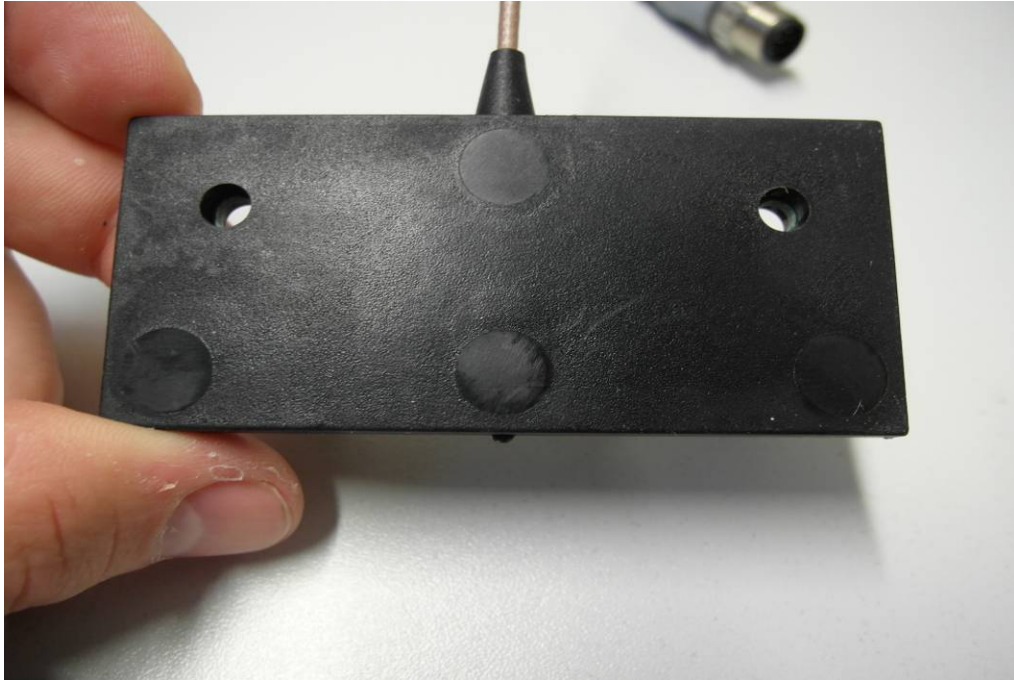

Photo 12:

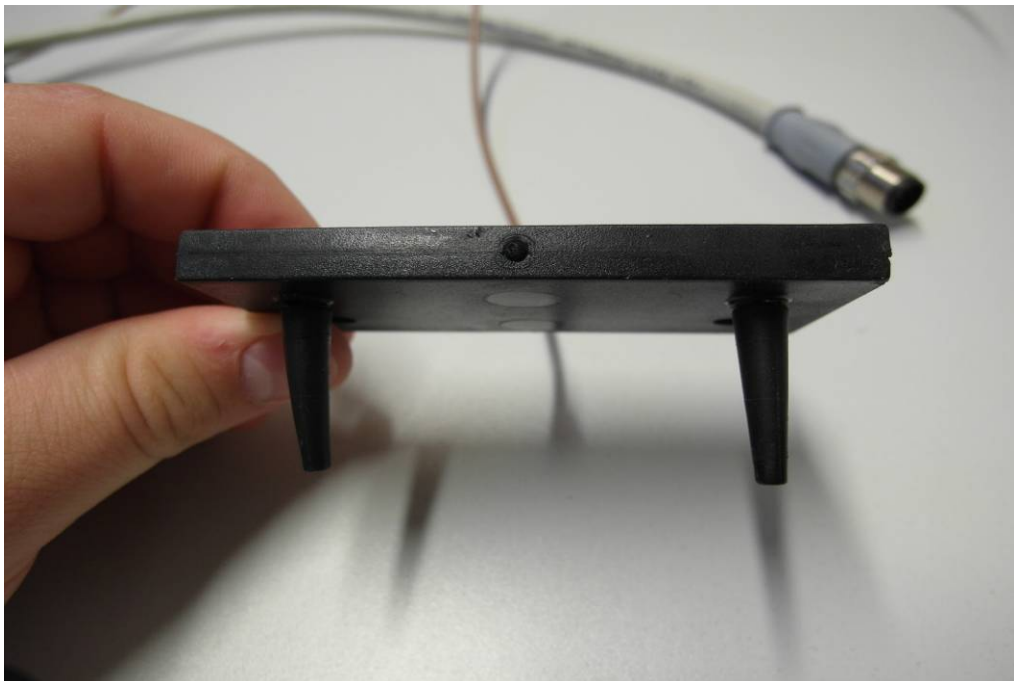

Photo 13:



Photo 14:



Annex C Internal photographs of the EUT

Photo documentation:

Photo 1:

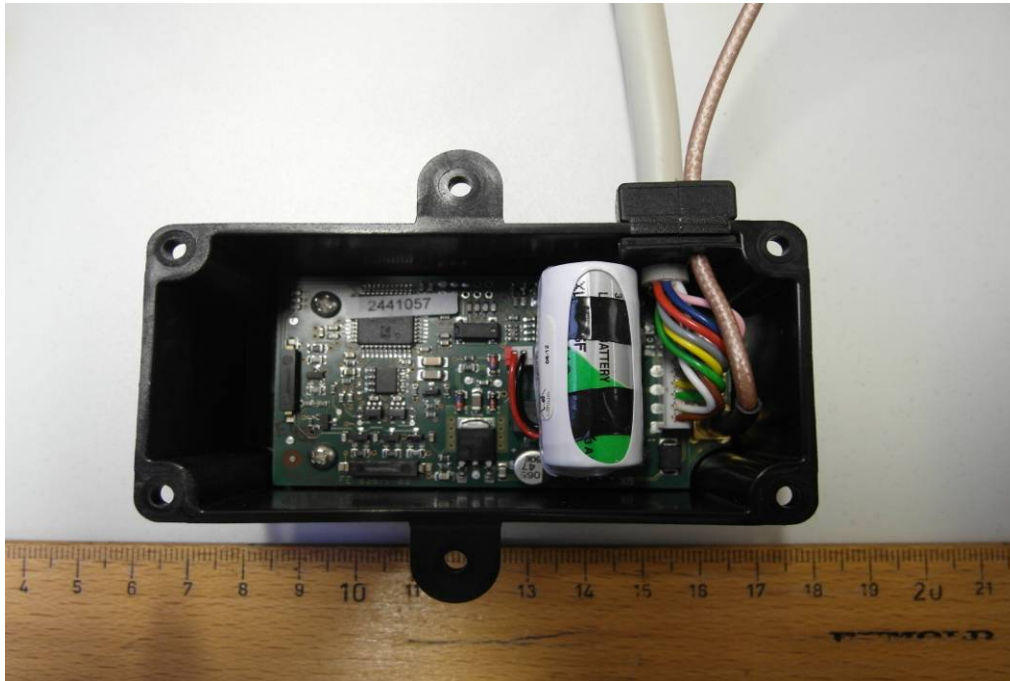

Photo 2:

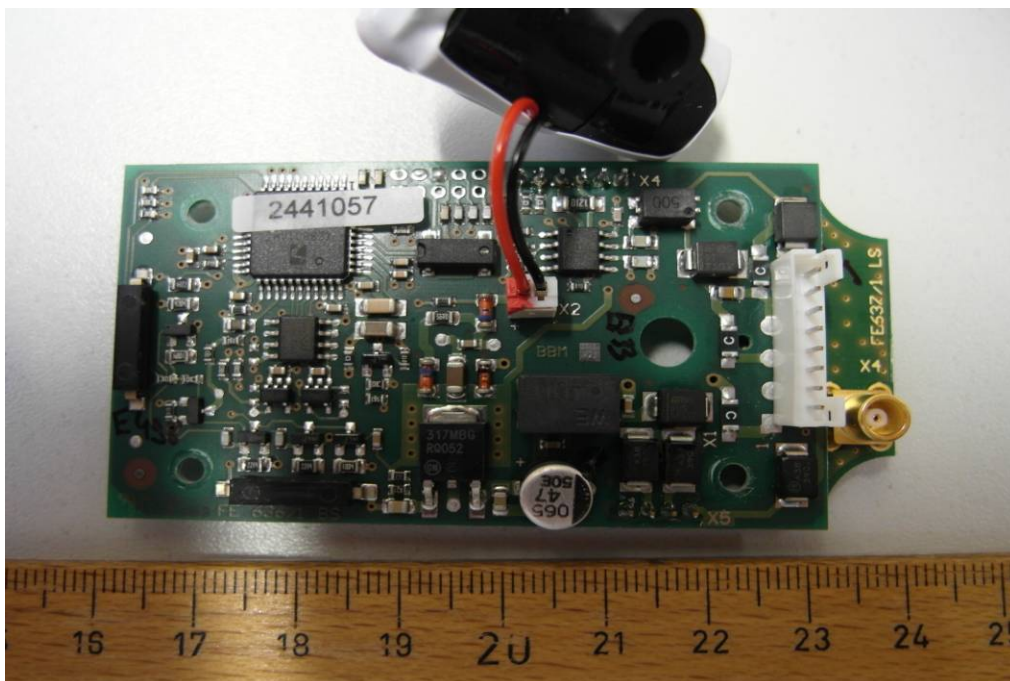

Photo 3:



Photo 4:



Photo 5:

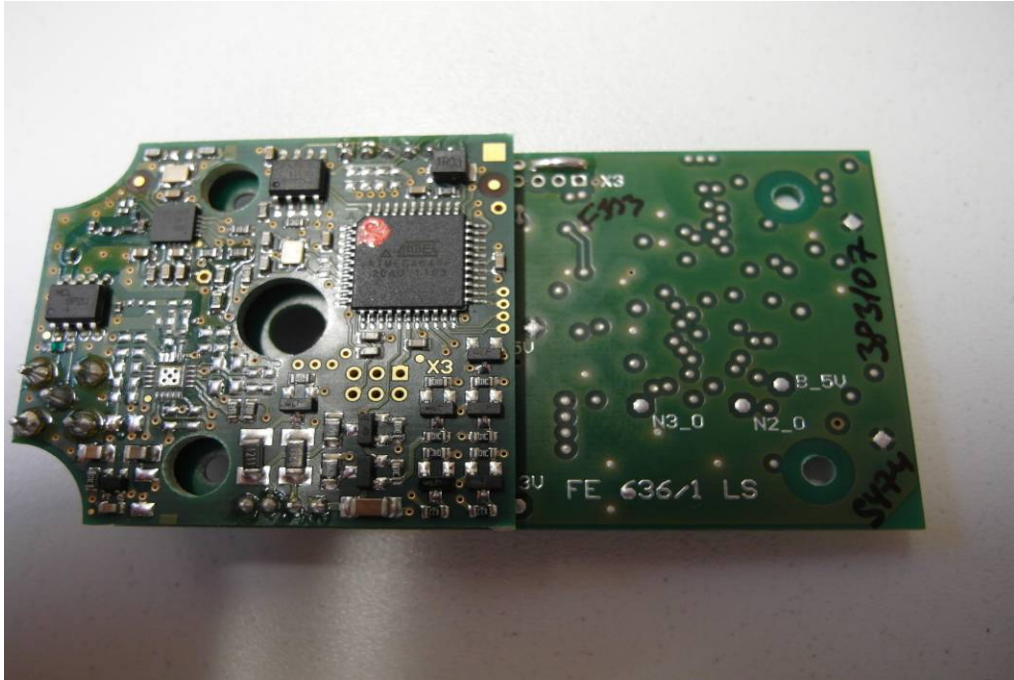

Photo 6:

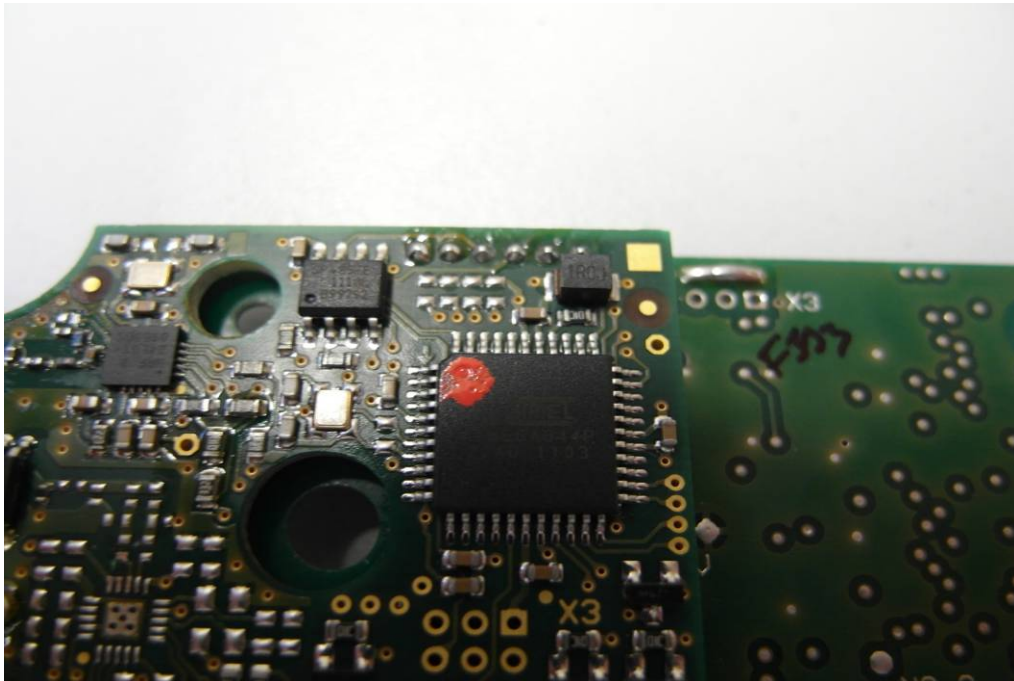

Photo 7:

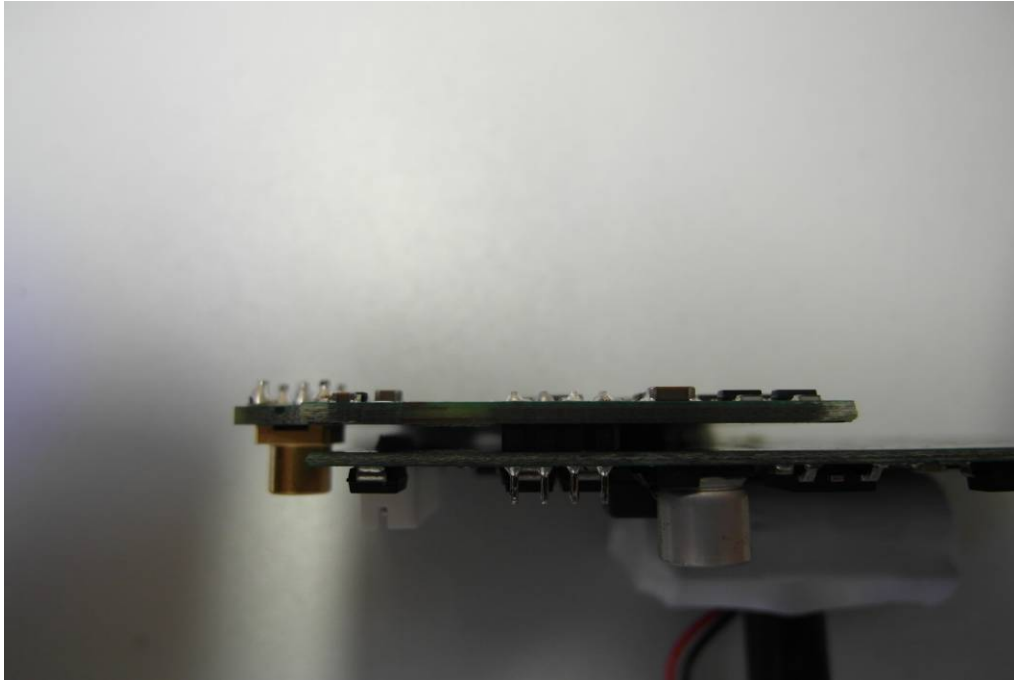

Photo 8:

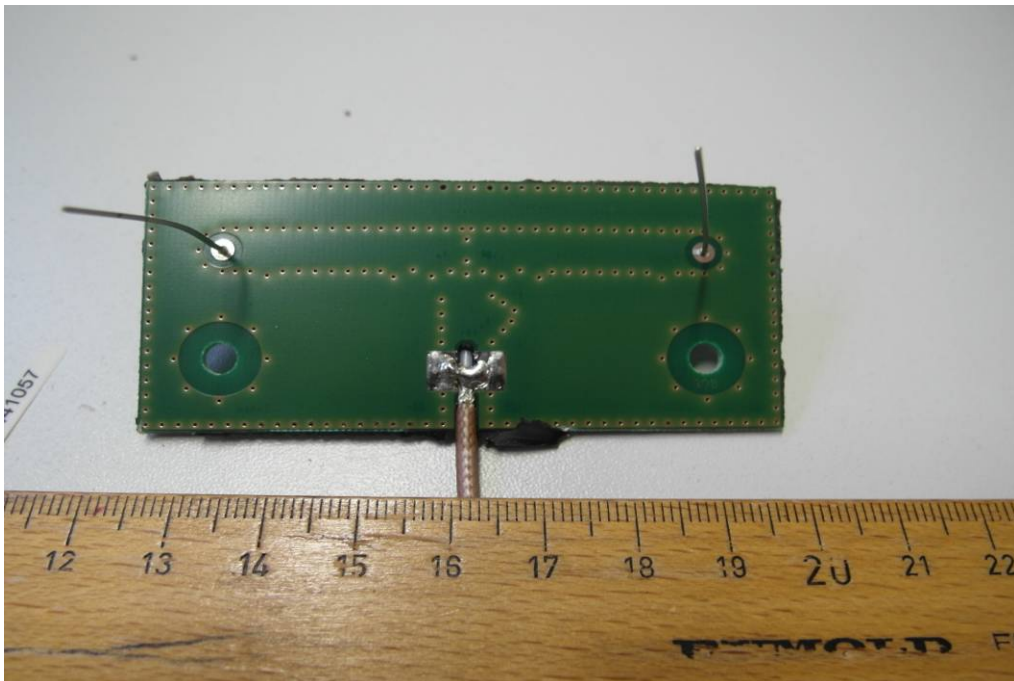
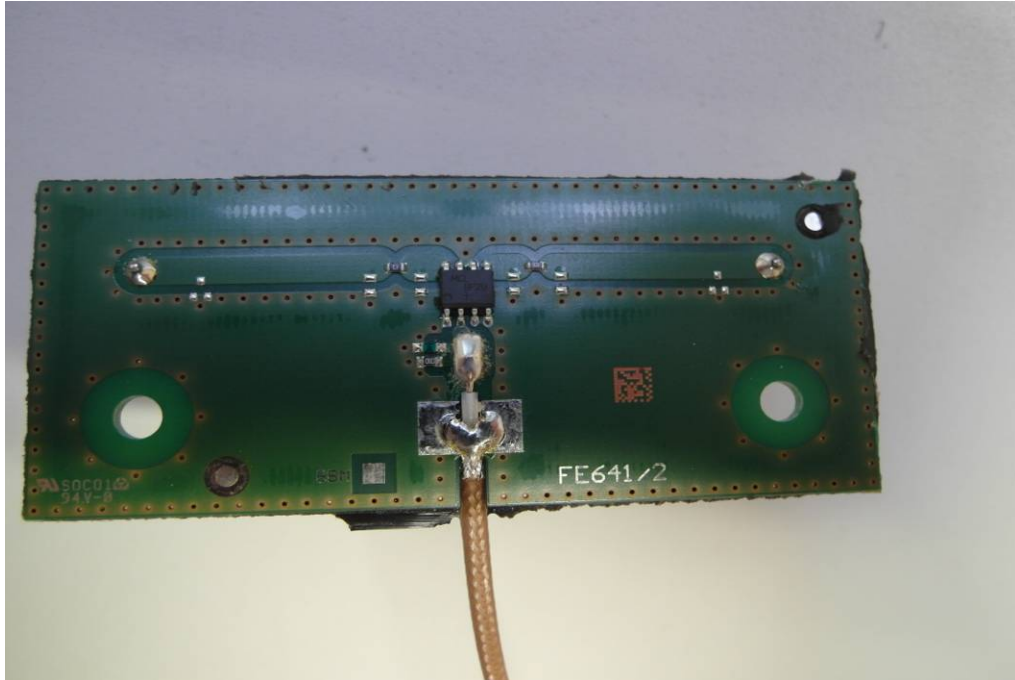

Photo 9:



Annex D Document history

Version	Applied changes	Date of release
1.0	Initial release	2012-09-04
-A	Addition of the measuring distance	2012-09-06
-B	Changing of product name	2012-09-19

Annex E Further information**Glossary**

AVG	-	Average
DUT	-	Device under test
EMC	-	Electromagnetic Compatibility
EN	-	European Standard
EUT	-	Equipment under test
ETSI	-	European Telecommunications Standard Institute
FCC	-	Federal Communication Commission
FCC ID	-	Company Identifier at FCC
HW	-	Hardware
IC	-	Industry Canada
Inv. No.	-	Inventory number
N/A	-	Not applicable
PP	-	Positive peak
QP	-	Quasi peak
S/N	-	Serial number
SW	-	Software

Annex F Accreditation Certificate



Front side of certificate



Back side of certificate

Note:

The current certificate including annex is published on our website (see link below) or may be received from CETECOM ICT Services on request.

http://www.cetecom.com/fileadmin/de/CETECOM_D_Saarbruecken/accreditations_Jan_2010/DAKKS_Akkredi_Urk_EN17025-En_incl_Annex.pdf