

Königswinkel 10

32825 Blomberg, Germany

Phone +49 (0) 52 35 95 00-0

Fax +49 (0) 52 35 95 00-10

office@phoenix-testlab.de

www.phoenix-testlab.de

Test Report

Report Number:

F160532E1

Equipment under Test (EUT):

MWD BPC-HU

Applicant:

FEIG ELECTRONIC GmbH

Manufacturer:

FEIG ELECTRONIC GmbH



Deutsche
Akkreditierungsstelle
D-PL-17186-01-01
D-PL-17186-01-02
D-PL-17186-01-03



References

- [1] **ANSI C63.10: 2013** American National Standard of Procedures for Compliance Testing of Unlicensed Wireless Devices
- [2] **FCC CFR 47 Part 15 (October 2015)** Radio Frequency Devices
- [3] **RSS-210 Issue 8 (December 2010)** Licence-exempt Radio Apparatus (All Frequency Bands): Category I Equipment
- [4] **RSS-Gen Issue 4 (November 2014)** General Requirements for Compliance of Radio Apparatus

TEST RESULT

The requirements of the tests performed as shown in the overview (clause 4) were fulfilled by the equipment under test.

The complete test results are presented in the following.

Test engineer:	Thomas KÜHN		02/01/2017
	Name	Signature	Date
Authorized reviewer:	Bernd STEINER		02/01/2017
	Name	Signature	Date

This test report is only valid in its original form.

Any reproduction of its contents in extracts without written permission of the accredited test laboratory PHOENIX TESTLAB GmbH is prohibited.

The test results herein refer only to the tested sample. PHOENIX TESTLAB GmbH is not responsible for any generalisations or conclusions drawn from these test results concerning further samples. Any modification of the tested samples is prohibited and leads to the invalidity of this test report. Each page necessarily contains the PHOENIX TESTLAB Logo and the TEST REPORT NUMBER.

Contents:	Page
1 Identification.....	4
1.1 Applicant.....	4
1.2 Manufacturer.....	4
1.3 Test laboratory.....	4
1.4 EUT (Equipment Under Test).....	5
1.5 Technical data of equipment.....	5
1.6 Dates.....	6
2 Operational states.....	6
3 Additional Information.....	7
4 Overview.....	7
5 Test results.....	8
5.1 Bandwidth.....	8
5.1.1 Method of measurement (bandwidth).....	8
5.1.2 Test results (20 dB bandwidth).....	9
5.1.3 Test results (99 % bandwidth).....	10
5.2 Band-edge compliance.....	11
5.2.1 Method of measurement (band-edge compliance).....	11
5.2.2 Test results (band-edge compliance).....	12
5.3 Radiated emissions.....	14
5.3.1 Method of measurement (radiated emissions).....	14
5.3.2 Test results (radiated emissions).....	21
5.3.2.1 Preliminary radiated emission measurement.....	21
5.3.3 Result final measurement from 9 kHz to 30 MHz.....	27
5.3.3.1 Final radiated emission measurement (30 MHz to 1 GHz).....	28
5.3.3.2 Final radiated emission measurement (1 GHz to 110 GHz).....	29
5.4 Conducted emissions on power supply line (150 kHz – 30 MHz).....	30
5.4.1 Method of measurement of conducted emission.....	30
5.4.2 Test results (conducted emission measurement on AC mains, EUT DC supplied).....	31
5.4.3 Test results (conducted emission measurement on AC mains, EUT AC supplied).....	32
6 Test equipment and ancillaries used for tests.....	33
7 Report history.....	35
8 List of annexes.....	35

1 Identification

1.1 Applicant

Name:	FEIG ELECTRONIC GmbH
Address:	Lange Straße 4 35781 Weilburg
Country:	Germany
Name for contact purposes:	Mr. Alwin SCHEU
Phone:	+49 64 71 31 09 -432
Fax:	+49 64 71 31 09 -99
eMail Address:	alwin.scheu@feig.de
Applicant represented during the test by the following person:	-

1.2 Manufacturer

Name:	FEIG ELECTRONIC GmbH
Address:	Lange Straße 4 35781 Weilburg
Country:	Germany
Name for contact purposes:	Mr. Alwin SCHEU
Phone:	+49 64 71 31 09 -432
Fax:	+49 64 71 31 09 -99
eMail Address:	alwin.scheu@feig.de
Manufacturer represented during the test by the following person:	-

1.3 Test laboratory

The tests were carried out at: **PHOENIX TESTLAB GmbH**
Königswinkel 10
32825 Blomberg
Germany

accredited by Deutsche Akkreditierungsstelle GmbH (DAkkS) in compliance with DIN EN ISO/IEC 17025 under Reg. No. D-PL-17186-01-02, FCC Test Firm Accreditation with the registration number 469623, designation number DE0004 and Industry Canada Test site registration SITE# IC3469A-1.

1.4 EUT (Equipment Under Test)

Test object: *	24 GHz doppler radar for motion detection
Model name / HVIN: *	MWD BPC-HU
FCC ID: *	PJMMWDBPC
IC: *	6633A-MWDBPC
Serial number: *	None
Hardware version: *	0.2-HU
Software version: *	V00-00.02
Lowest internal frequency: *	4 MHz

1.5 Technical data of equipment

Channel 1 *	RX:	24.075 GHz to 24.175 GHz	TX:	24.075 GHz to 24.175 GHz		
Channel 2 *	RX:	-	TX:	-		
Duty cycle:*	100 %					
Rated RF output power: *	< +20 dBm (e.i.r.p.)					
Antenna type:	Integral patch antenna					
Alignment range: *	24.075 GHz to 24.175 GHz					
Switching range: *	24.075 GHz to 24.175 GHz					
Modulation: *	CW					
Bit rate of transmitter: *	-					
Supply Voltage: *	$U_{Nom} =$	24.0 V _{DC}	$U_{Min} =$	12.0 V _{DC}	$U_{Max} =$	30.0 V _{DC}
Power Supply: *	External					
Temperature range: *	-20 °C to +55 °C					
Ancillaries to be tested with:	An external power supply type Mini-PS-100-240AC/24DC/1 was used during conducted emission measurement on power supply line while EUT supplied with DC. An isolating regulating transformer type B9701089 was used while the EUT supplied with AC. USB to CAN converter type IXXAT ** and two CAN to fibre optics converter SonTec type Optocan 2000.					

*: Declared by the applicant.

**: Provided by the applicant.

The following external I/O cables were used:

Identification	Connector		Length
	EUT	Ancillary	
Connection cable 1 (DC and CAN-bus)	4 pole M8 plug	-	2.5 m
Connection cable 1 (DC and CAN-bus)	4 pole M8 plug	CAN-termination	10 cm
-	-	-	-

*: As declared by the applicant, this interface is used during manufacturing only.

1.6 Dates

Date of receipt of test sample:	06/28/2016
Start of test:	06/29/2016
End of test:	07/01/2016

2 Operational states

All tests were carried out with an unmodified sample with integral antenna.

All measurements were carried out with the EUT supplied with 24.0 V_{DC}, because pre-tests have shown that there is no noticeable difference of the output signal with respect to the supply voltage.

The EUT is a motion detector, which is intended to be used in combination with building door / gate openers.

Because the final position of the EUT is unknown, the measurements were carried out in two directions of the EUT. These positions were defined as follows:

Position 1: Antenna patch shows to the measuring antenna, EUTs connector shows downwards.

Position 2: Antenna patch shows upwards to the ceiling.

For details of these positions refer also the photographs in annex A of this test report.

No tests in stand-by mode of the transmitter / receive mode were carried out, because the transmitter is operating continuously and has no stand-by mode.

The EUT has two connection lines which containing the CAN-bus and the DC supply line. One of these lines was used to supply the EUT and communicate with the tests software on a laptop PC via a USB to CAN converter type IXXAT and two CAN to fibre optics converter. The other line was terminated with the CAN-bus termination, which is part of the shipment.

For the whole frequency range a preliminary measurement in a fully anechoic chamber was carried out to determine the frequencies, which were radiated by the EUT. The final measurements on the detected frequencies were carried out on an outdoor test site without ground plane (for the frequency range 9 kHz to 30 MHz), on an open area test site with ground plane (for the frequency range 30 MHz to 1 GHz) or the fully anechoic chamber (for the frequency range 1 GHz to 110 GHz).

The physical boundaries of the Equipment Under Test are shown below.

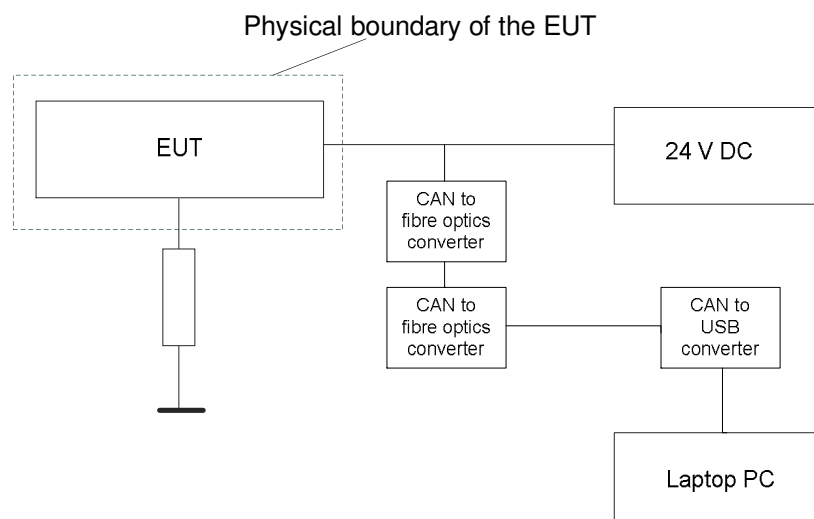

3 Additional Information

The EUT used for the tests was not labeled as required by FCC / IC.

4 Overview

Application	Frequency range	FCC 47 CFR Part 15 section [2]	RSS-210, issue 8 [3]; RSS-Gen, issue 4 [4]	Status	Refer page
20 dB / 99 % bandwidth	24.075 GHz to 24.175 GHz	15.215 (c)	6.6 [4]	Passed	8 et seq.
Band edge compliance	24.075 GHz to 24.175 GHz	15.215 (c)	2.5 [4]	Passed	10 et seq.
Field strength of fundamental	24.075 GHz to 24.175 GHz	15.245 (b)	Annex 7 [3]	Passed	14 et seq.
Field strength of harmonics	Restricted bands	15.245 (b) (1) (ii), 15.245 (b) (1) (iii)	Annex 7 [3]	Passed	14 et seq.
Emissions outside the specified bands	9 kHz to 110 GHz	15.205 (a), 15.209 (a), 15.245 (3)	Annex 7 (1) [3], 8.9 [4], 8.10 [4]	Passed	14 et seq.
Conducted emissions	150 kHz to 30 MHz	15.207	8.8 [4]	Passed	30 et seq.
Antenna requirement	-	15.203 [2]	-	Passed*	-

*: Integrated antenna only, requirement fulfilled.

5 Test results

5.1 Bandwidth

5.1.1 Method of measurement (bandwidth)

The calibration of the spectrum analyser has to be checked with the help of a known signal from a signal generator. The EUT has to be connected to the spectrum analyser via a low loss cable. If the EUT is not equipped with an antenna connector, a temporary antenna connector has to be installed or a test fixture shall be used. The EUT has to be switched on; the transmitter shall work with its maximum data rate.

The following spectrum analyser settings according to [1] shall be used:

- Span: App. 2 to 5 times the 20 dB bandwidth, centred on the actual channel.
- Resolution bandwidth: 1 to 5 % of the occupied bandwidth.
- Video bandwidth: App. three times the resolution bandwidth.
- Sweep: Auto.
- Detector function: peak.
- Trace mode: Max hold.

20 dB bandwidth:

After trace stabilisation the marker shall be set on the signal peak. The first display line has to be set on this value. The second display line has to be set 20 dB below the first line (or the peak marker). The frequency lines shall be set on the intersection points between the second display line and the measured curve.

99 % bandwidth:

After trace stabilisation the marker shall be set on the signal peak. The power measurement function of the spectrum analyser has to be used to determine the 99 % bandwidth.

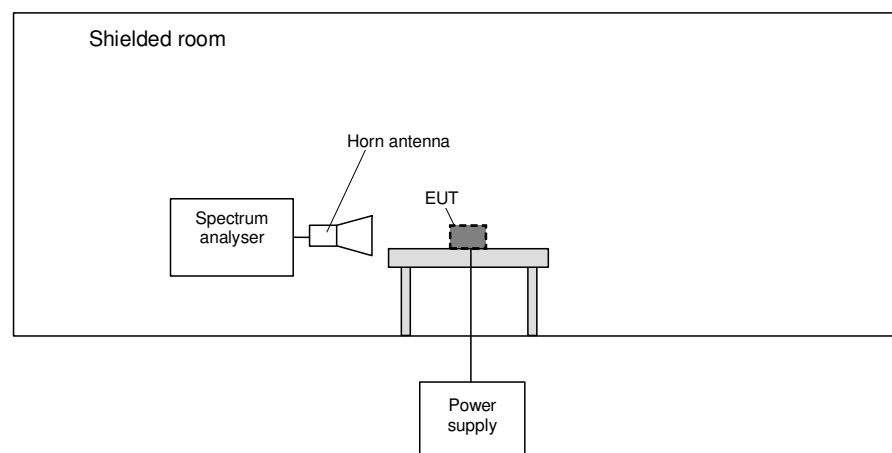

5.1.2 Test results (20 dB bandwidth)

Ambient temperature	22 °C	Relative humidity	60 %
---------------------	-------	-------------------	------

Position of EUT: The EUT was setup 30 cm in front of the measuring antenna

Supply voltage: During all measurements the EUT was supplied by an external 24 V_{DC}-Power-Supply.

160532_211.wmf: 20 dB bandwidth:

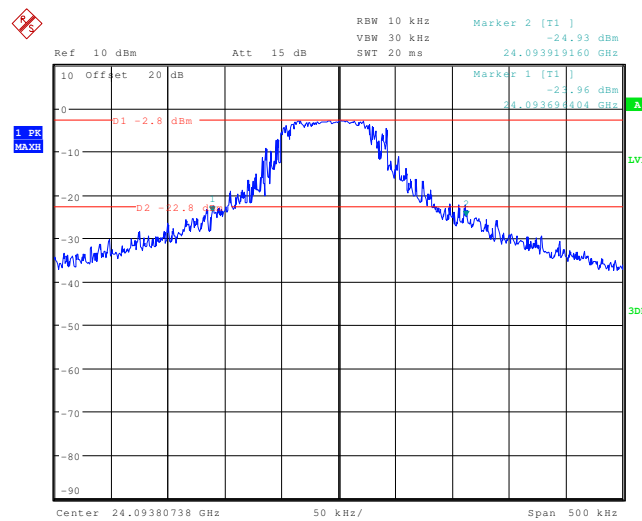

F_L	F_U	BW ($F_U - F_L$)
24.093696 GHz	24.093919 GHz	223.000 kHz
Measurement uncertainty		$< \pm 1 \cdot 10^{-7}$

Test: Passed

Test equipment used for the test (see chapter 6):

29, 40, 52, 149, 165, 176

5.1.3 Test results (99 % bandwidth)

Ambient temperature	22 °C	Relative humidity	60 %
---------------------	-------	-------------------	------

Position of EUT: The EUT was setup 30 cm in front of the measuring antenna

Supply voltage: During all measurements the EUT was supplied by an external 24 V_{DC}-Power-Supply.

160532_212.wmf: 99 % bandwidth:

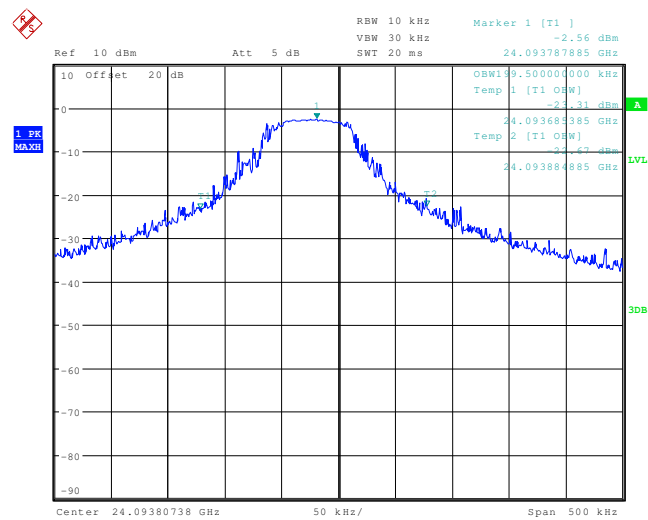

F_L	F_U	BW ($F_U - F_L$)
24.093685 GHz	24.093885 GHz	199.5 kHz
Measurement uncertainty		$< \pm 1 \cdot 10^{-7}$

Test: Passed

Test equipment used for the test (see chapter 6):

29, 40, 52, 149, 165, 176 - 178

5.2 Band-edge compliance

5.2.1 Method of measurement (band-edge compliance)

The same test setup as used for the final radiated emission measurement shall be used. The measurements shall be carried out with using a resolution bandwidth of 100 kHz.

The following spectrum analyser settings shall be used:

- Span: Wide enough to capture the peak level of the emission on the channel closest to the band-edge, as well as any modulation products, which fall outside the assigned frequency band.
- Resolution bandwidth: 100 kHz.
- Video bandwidth: \geq the resolution bandwidth.
- Sweep: Auto.
- Detector function: Peak.
- Trace mode: Max hold.

After trace stabilisation the marker shall be set on the signal peak. The frequency line shall be set on the edge of the assigned frequency band. Set the second marker on the emission at the band-edge, or on the highest modulation product outside of the band, if this level is higher than that at the band-edge. This frequency shall be measured with the EMI receiver as described in subclause 5.2.1 of this test report, but 100 kHz resolution bandwidth shall be used.

The measurement will be performed at the lower and upper end of the assigned frequency band.

5.2.2 Test results (band-edge compliance)

Ambient temperature	22 °C	Relative humidity	60 %
---------------------	-------	-------------------	------

160532_213.wmf: Band-edge compliance, lower band edge:

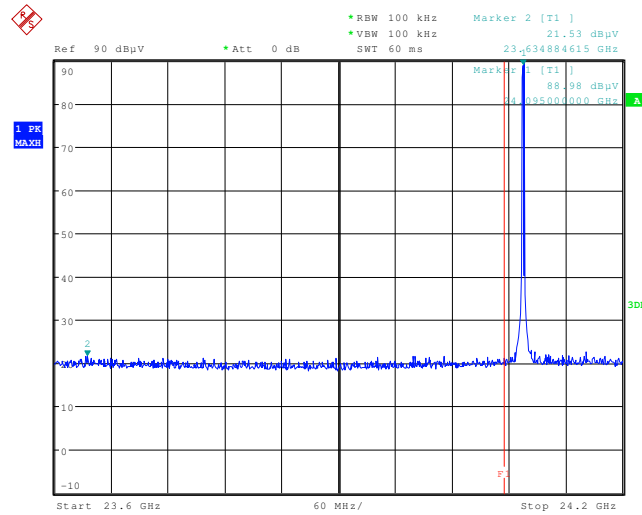

160532_214.wmf: Band-edge compliance, upper band edge:

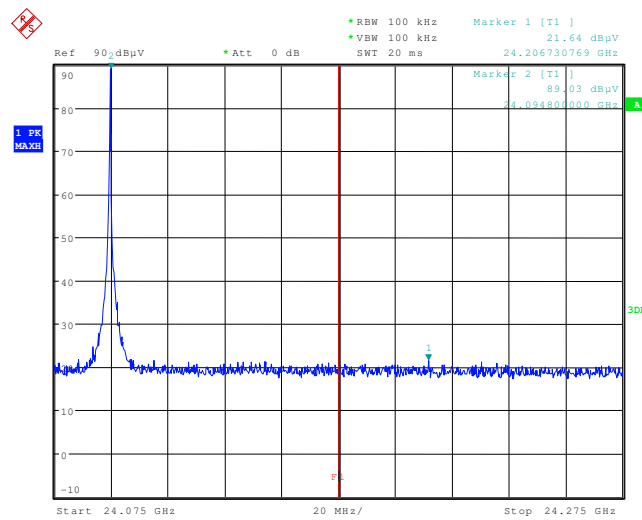

The plots on the page before are showing the band-edge compliance for the lower and upper band-edge. The frequency line 1 (F1) shows the edge of the assigned frequency.

Band-edge compliance (lower band edge)									
Result measured with the peak detector:									
Frequency GHz	Result dB μ V/m	Limit (3 m) dB μ V/m	Margin dB	Readings dB μ V	Antenna factor 1/m	Preamp dB	Cable loss dB	Corr. factor from 3 m to 30 cm	Restr. Band
23.634885	43.3	54.0	9.7	21.5	37.2	0.0	4.6	-20.0 dB	Yes
Measurement uncertainty							-3.6 dB / +2.2 dB		

Band-edge compliance (upper band edge)									
Result measured with the peak detector:									
Frequency GHz	Result dB μ V/m	Limit (3 m) dB μ V/m	Margin dB	Readings dB μ V	Antenna factor 1/m	Preamp dB	Cable loss dB	Corr. factor from 3 m to 30 cm	Restr. Band
24.206731	43.4	54.0	9.6	21.6	37.2	0.0	4.9	-20.0 dB	No
Measurement uncertainty							-3.6 dB / +2.2 dB		

Remark: No measurement with an average detector was carried out, because the peak value is already below the average limit.

Test: Passed

Test equipment used for the test (see chapter 6):

29, 40, 52, 149, 165, 176 - 178

5.3 Radiated emissions

5.3.1 Method of measurement (radiated emissions)

The radiated emission measurement is subdivided into 5 stages.

- A preliminary measurement carried out in a fully anechoic chamber with a fixed antenna height in the frequency range 9 kHz to 1 GHz.
- A final measurement carried out on an outdoor test site without reflecting ground plane and a fixed antenna height in the frequency range 9 kHz to 30 MHz.
- A final measurement carried out on an open area test site with reflecting ground plane and various antenna heights in the frequency range 30 MHz to 1 GHz.
- A preliminary measurement carried out in a fully anechoic chamber with a variable antenna distance and height in the frequency range 1 GHz to 110 GHz.
- A final measurement carried out in a fully anechoic chamber with a fixed antenna height in the frequency range 1 GHz to 110 GHz.

Preliminary measurement (9 kHz to 30 MHz):

In the first stage a preliminary measurement will be performed in a shielded room with a measuring distance of 3 meters. Tabletop devices will set up on a non-conducting support with a size of 1 m by 1.5 m and a height of 80 cm. Floor-standing devices will be placed directly on the turntable/ground plane. The setup of the Equipment under test will be in accordance to [1].

The frequency range 9 kHz to 30 MHz will be monitored with a spectrum analyser while the system and its cables will be manipulated to find out the configuration with the maximum emission levels if applicable. The EMI Receiver will be set to MAX Hold mode. The EUT and the measuring antenna will be rotated around their vertical axis to found the maximum emissions.

The resolution bandwidth of the spectrum analyser will be set to the following values:

Frequency range	Resolution bandwidth
9 kHz to 150 kHz	200 Hz
150 kHz to 30 MHz	10 kHz

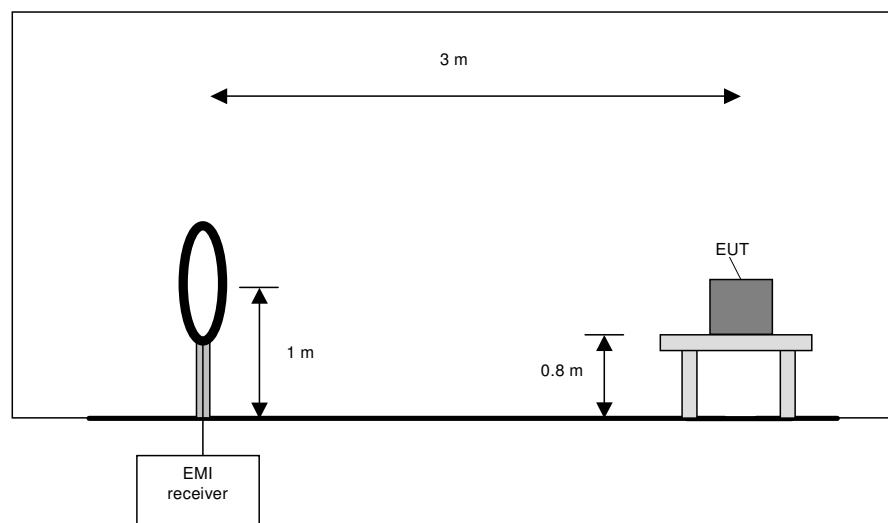

Preliminary measurement procedure:

Prescans were performed in the frequency range 9 kHz to 150 kHz and 150 kHz to 30 MHz.

The following procedure will be used:

- 1) Monitor the frequency range at horizontal polarisation and a EUT azimuth of 0 °.
- 2) Manipulate the system cables within the range to produce the maximum level of emission.
- 3) Rotate the EUT by 360 ° to maximize the detected signals.
- 4) Make a hardcopy of the spectrum.
- 5) Measure the frequencies of highest detected emission with a lower span and resolution bandwidth to increase the accuracy and note the frequency value.
- 6) Repeat steps 1) to 5) with the other orthogonal axes of the EUT (only if the EUT is a module or is used in a handheld application).
- 7) Rotate the measuring antenna and repeat steps 1) to 5).

Final measurement (9 kHz to 30 MHz):

In the second stage a final measurement will be performed on an open area test site with no conducting ground plane in a measuring distances of 3 m, 10 m and 30 m whichever is appropriate. In the case where larger measuring distances were required the results will be extrapolated based on the values measured on the closer distances according to [2]. The final measurement will be performed with a EMI Receiver set to Quasi Peak detector except for the frequency bands 30 kHz to 90 kHz and 110 kHz to 490 kHz where an average detector will be used according to [2].

On the during the preliminary measurement detected frequencies the final measurement will be performed while rotating the EUT and the measuring antenna in the range of 0 ° to 360 ° around their vertical axis until the maximum value is found.

The resolution bandwidth of the EMI Receiver will be set to the following values:

Frequency range	Resolution bandwidth
9 kHz to 150 kHz	200 Hz
150 kHz to 30 MHz	9 kHz

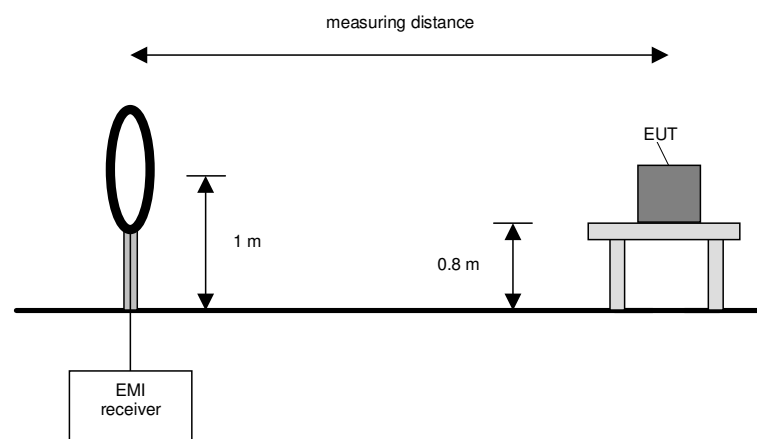

Final measurement procedure:

The following procedure will be used:

- 1) Monitor the frequency range with the measuring antenna at vertical orientation parallel to the EUT at an azimuth of 0 °.
- 2) Rotate the EUT by 360 ° to maximize the detected signals and note the azimuth and orientation.
- 3) Rotate the measuring antenna to find the maximum and note the value.
- 4) Rotate the measuring antenna and repeat steps 1) to 3) until the maximum value is found.
- 5) Repeat steps 1) to 4) with the other orthogonal axes of the EUT (only if the EUT is a module or is used in a handheld application).

Preliminary measurement (30 MHz to 1 GHz)

In the first stage a preliminary measurement will be performed in a fully anechoic chamber with a measuring distance of 3 meter. Table top devices will set up on a non-conducting support with a size of 1 m by 1.5 m and a height of 80 cm. Floor-standing devices will be placed directly on the turntable/ground plane. The setup of the Equipment under test will be in accordance to [1].

The frequency range 30 MHz to 1 GHz will be measured with an EMI Receiver set to MAX Hold mode and a resolution bandwidth of 100 kHz. The measurement will be performed in horizontal and vertical polarisation of the measuring antenna and while rotating the EUT in its vertical axis in the range of 0 ° to 360 °.

The resolution bandwidth of the EMI Receiver will be set to the following values:

Frequency range	Resolution bandwidth
30 MHz to 1 GHz	100 kHz

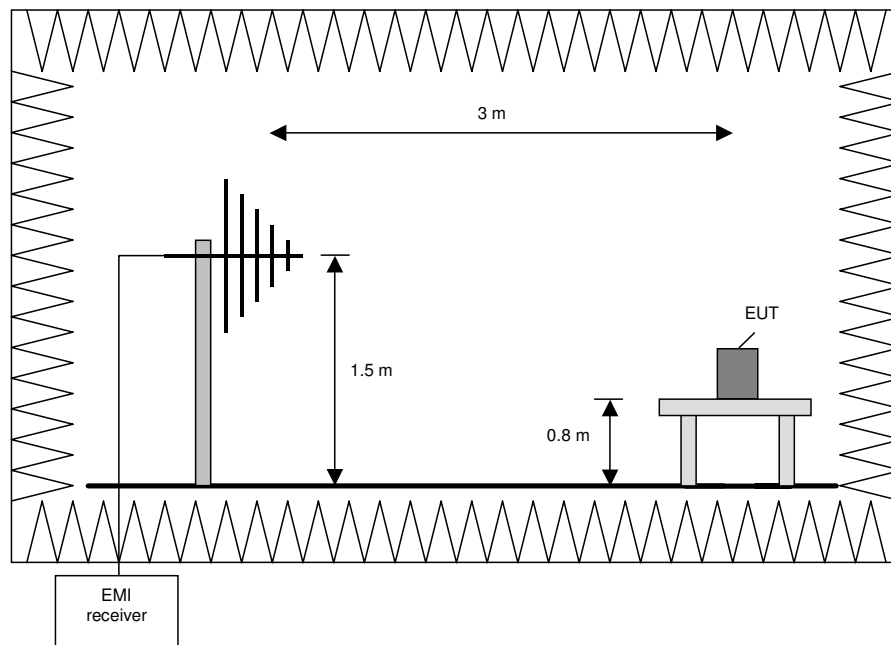

Procedure preliminary measurement:

Prescans were performed in the frequency range 30 MHz to 1 GHz.

The following procedure will be used:

1. Monitor the frequency range at horizontal polarisation and a EUT azimuth of 0 °.
2. Manipulate the system cables within the range to produce the maximum level of emission.
3. Rotate the EUT by 360 ° to maximize the detected signals.
4. Make a hardcopy of the spectrum.
5. Measure the frequency of the detected emissions with a lower span and resolution bandwidth to increase the accuracy and note the frequency value.
6. Repeat 1) to 4) with the other orthogonal axes of the EUT (only if the EUT is a module or is used in a handheld application).
7. Repeat 1) to 5) with the vertical polarisation of the measuring antenna.

Final measurement (30 MHz to 1 GHz)

A final measurement on an open area test site will be performed on selected frequencies found in the preliminary measurement. During this test the EUT will be rotated in the range of 0 ° to 360 °, the measuring antenna will be set to horizontal and vertical polarisation and raised and lowered in the range from 1 m to 4 m to find the maximum level of emissions.

The resolution bandwidth of the EMI Receiver will be set to the following values:

Frequency range	Resolution bandwidth
30 MHz to 1 GHz	120 kHz

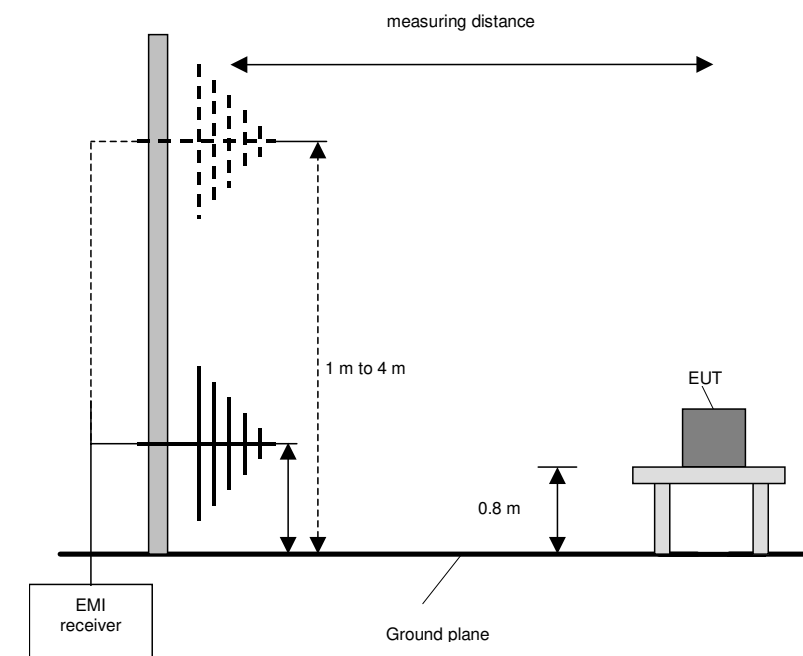

Procedure final measurement:

The following procedure will be used:

- 1) Measure on the selected frequencies at an antenna height of 1 m and a EUT azimuth of 23 °.
- 2) Move the antenna from 1 m to 4 m and note the maximum value at each frequency.
- 3) Rotate the EUT by 45 ° and repeat 2) until an azimuth of 337 ° is reached.
- 4) Repeat 1) to 3) for the other orthogonal antenna polarization.
- 5) Move the antenna and the turntable to the position where the maximum value is detected.
- 6) Measure while moving the antenna slowly +/- 1 m.
- 7) Set the antenna to the position where the maximum value is found.
- 8) Measure while moving the turntable +/- 45 °.
- 9) Set the turntable to the azimuth where the maximum value is found.
- 10) Measure with Final detector (QP and AV) and note the value.
- 11) Repeat 5) to 10) for each frequency.
- 12) Repeat 1) to 11) for each orthogonal axes of the EUT (only if the EUT is a module or is used in a handheld application).

Preliminary and final measurement (1 GHz to 110 GHz)

This measurement will be performed in a fully anechoic chamber. Table top devices will set up on a non-conducting turn device on the height of 1.5 m. The set-up of the Equipment under test will be in accordance to [1].

Preliminary measurement (1 GHz to 40 GHz)

The frequency range will be divided into different sub ranges depending of the frequency range of the used horn antenna. The spectrum analyser set to MAX Hold mode and a resolution bandwidth of 100 kHz. The measurement will be performed in horizontal and vertical polarisation of the measuring antenna and while rotating the EUT in its vertical axis in the range of 0 ° to 360 °. This measurement is repeated after raising the EUT in 30 ° steps according 6.6.5.4 in [1].

The resolution bandwidth of the EMI Receiver will be set to the following values:

Frequency range	Resolution bandwidth
1 GHz to 4 GHz	1 MHz
4 GHz to 12 GHz	1 MHz
12 GHz to 18 GHz	1 MHz
18 GHz to 26.5 GHz	1 MHz
26.5 GHz to 40 GHz	1 MHz
40 GHz to 60 GHz	1 MHz
50 GHz to 75 GHz	1 MHz
75 GHz to 110 GHz	1 MHz

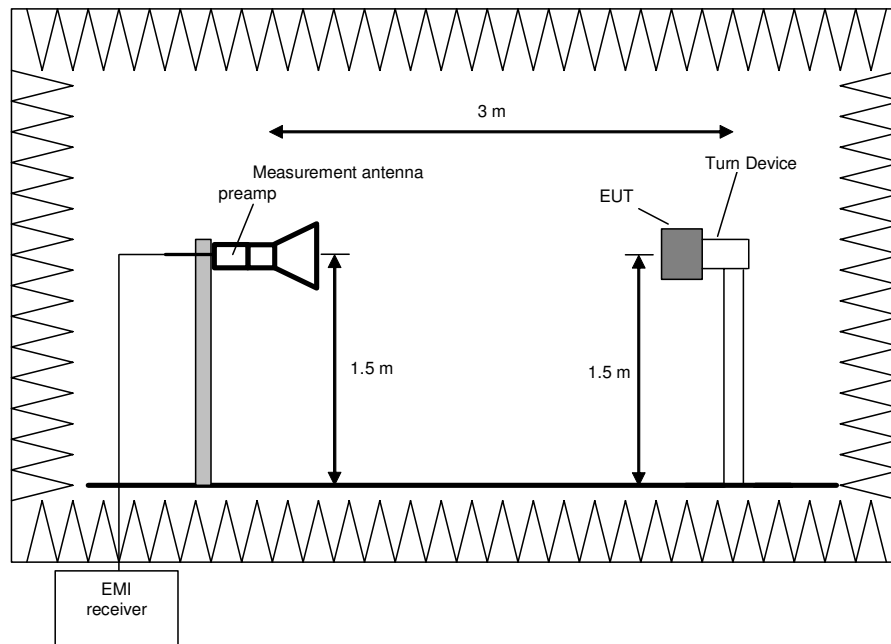

Procedure preliminary measurement:

Prescans were performed in the frequency range 1 to 40 GHz.

The following procedure will be used:

1. Monitor the frequency range at horizontal polarisation and a EUT azimuth of 0 °.
2. Rotate the EUT by 360° to maximize the detected signals.
3. Repeat 1) to 2) with the vertical polarisation of the measuring antenna.
4. Make a hardcopy of the spectrum.
5. Repeat 1) to 4) with the EUT raised by an angle of 30° (60°, 90°, 120° and 150°) according to 6.6.5.4 in [1].
6. Measure the frequency of the detected emissions with a lower span and resolution bandwidth to increase the accuracy and note the frequency value.
7. The measurement antenna polarisation, with the according EUT position (Turntable and Turn device) which produces the highest emission for each frequency will be used for the final measurement. The six closest values to the applicable limit will be used for the final measurement.

Final measurement (1 GHz to 110 GHz)

The frequency range will be divided into different sub ranges depending of the frequency range of the used antenna. The EMI Receiver set to peak and average mode and a resolution bandwidth of 1 MHz. The measurement will be performed by rotating the turntable through 0 to 360° in the worst-case EUT orientation which was obtained during the preliminary measurements.

The resolution bandwidth of the EMI Receiver will be set to the following values:

Frequency range	Resolution bandwidth
1 GHz to 4 GHz	1 MHz
4 GHz to 12 GHz	1 MHz
12 GHz to 18 GHz	1 MHz
18 GHz to 26.5 GHz	1 MHz
26.5 GHz to 40 GHz	1 MHz
40 GHz to 60 GHz	1 MHz
50 GHz to 75 GHz	1 MHz
75 GHz to 110 GHz	1 MHz

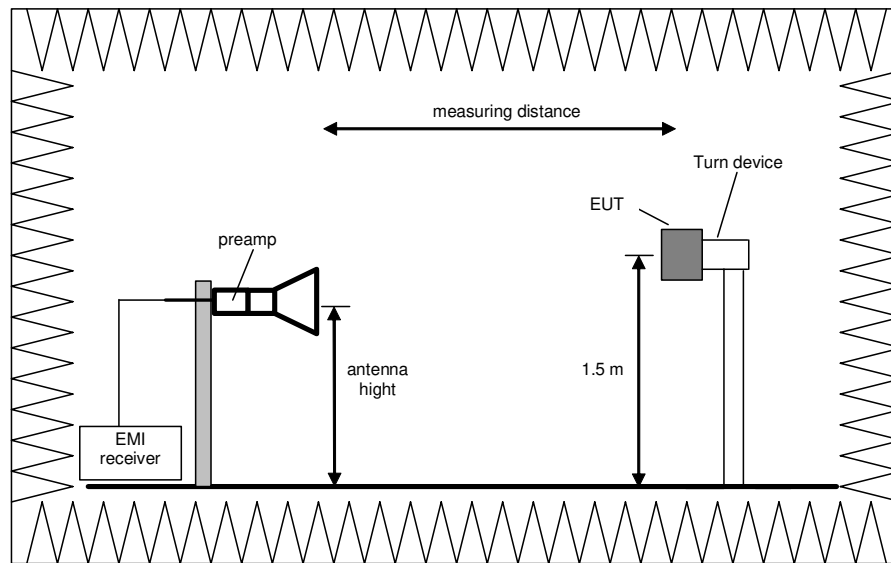

Procedure of measurement:

The measurements were performed in the frequency range 1 GHz to 110 GHz.

The following procedure will be used:

- 1) Set the turntable and the turn device to obtain the worst-case emission for the first frequency identified in the preliminary measurements.
- 2) Set the measurement antenna polarisation to the orientation with the highest emission for the first frequency identified in the preliminary measurements.
- 3) Set the spectrum analyser to EMI mode with peak and average detector activated.
- 4) Rotate the turntable from 0° to 360° to find the EUT angle that produces the highest emissions.
- 5) Note the highest displayed peak and average values
- 6) Repeat the steps 1) to 5) for each frequency detected during the preliminary measurements.

5.3.2 Test results (radiated emissions)

5.3.2.1 Preliminary radiated emission measurement

Ambient temperature	22 °C	Relative humidity	61 %
---------------------	-------	-------------------	------

Position of EUT: The EUT was setup on a non-conducting table of a height of 0.8 m. The distance between EUT and the antenna was 3 m (9 kHz to 1 GHz).

Cable guide: For further information refer to the pictures in annex A of this test report.

Test record: The test was carried out in normal operation mode of the EUT.

Supply voltage: The EUT was supplied by an external 24.0 V_{DC}-Power Supply.

Frequency range: The preliminary measurement was carried out in the frequency range 10 MHz to 110 GHz according to [2].

Measuring distance: 1 MHz to 30 MHz: 3 m
 30 MHz to 12 GHz: 3 m
 12 GHz to 18 GHz and 26.5 GHz to 40 GHz: 1 m
 18 GHz to 26.5 GHz and 40 GHz to 110 GHz: 30 cm

160532_201.wmf: Radiated emissions from 1 MHz to 30 MHz:

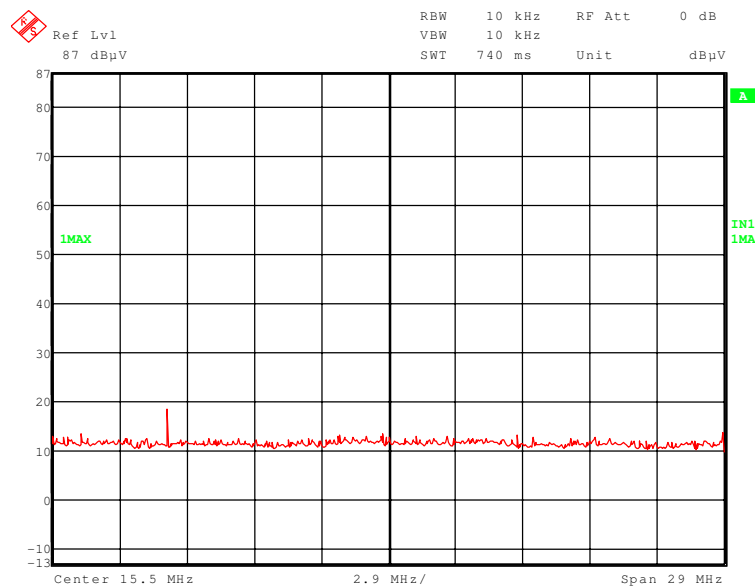

The following frequency was found during the preliminary radiated emission measurement:

- 5.960 MHz

This frequency has to be measured on the outdoor test site. The result is presented in the following.

Test equipment used for the test (see chapter 6):

29, 31 - 37, 43 - 45, 49, 52, 55, 146, 149, 150, 153 - 155, 159, 161, 165, 176 - 178
--

160532_202.wmf: Radiated emissions from 30 MHz to 1 GHz:

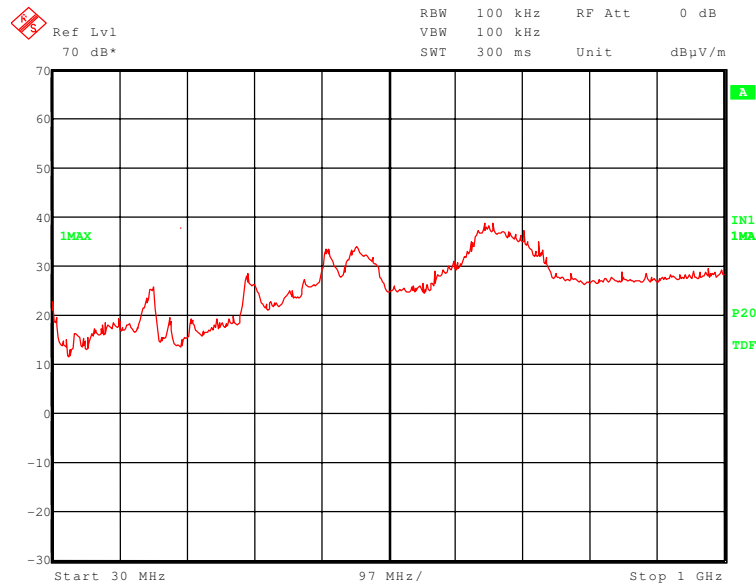

The following frequencies were found outside the restricted bands during the preliminary radiated emission measurement:

- 174.341 MHz, 309.901 MHz, 426.140 MHz, 466.356 MHz and 655.600 MHz.

No frequencies were found inside the restricted bands during the preliminary radiated emission measurement.

These frequencies have to be measured on the open area test site. The result is presented in the following.

160532_207.wmf: Radiated emissions from 26.5 GHz to 40 GHz:

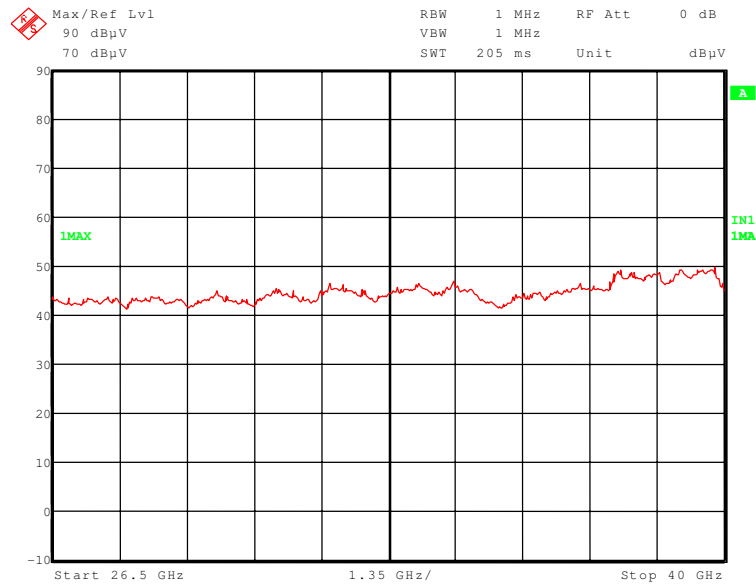

160532_208.wmf: Radiated emissions from 40 GHz to 60 GHz:

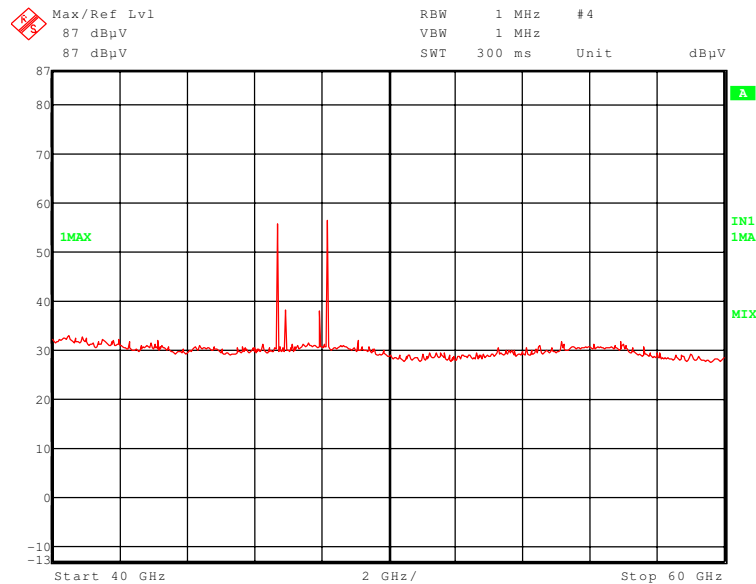

Remark: Peak at 48.2 GHz is an emission; the other peaks are mirror frequencies.

160532_209.wmf: Radiated emissions from 60 GHz to 75 GHz:

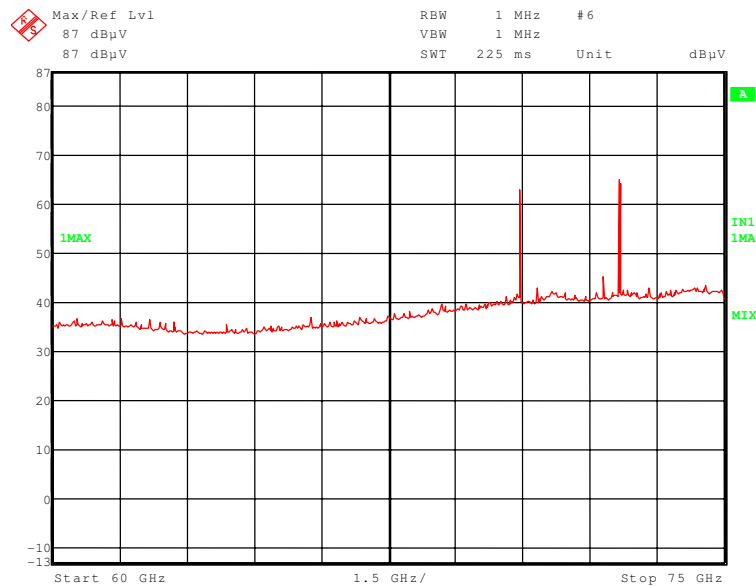

Remark: Peak at 72.3 GHz is an emission; the other peaks are mirror frequencies.

160532_210.wmf: Radiated emissions from 75 GHz to 110 GHz:

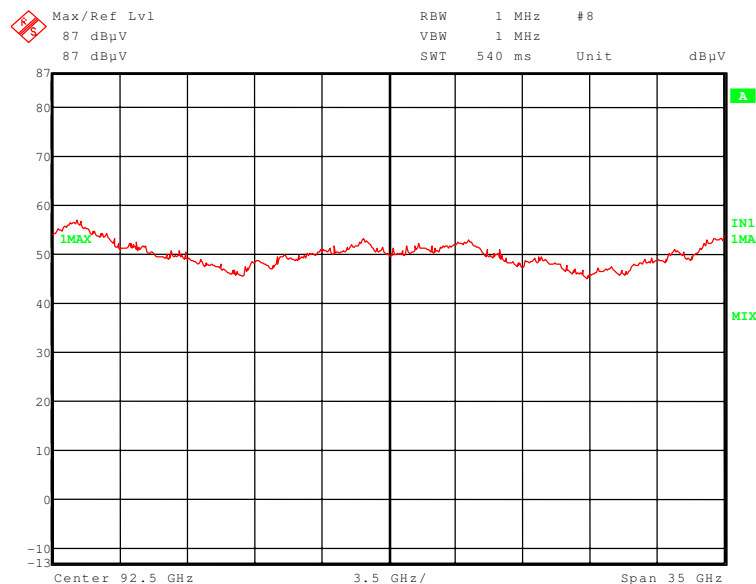

The frequencies were found inside the restricted bands during the preliminary radiated emission measurement.

- 48.200 GHz, 72.300 GHz.

The following frequency was found outside the restricted bands during the preliminary radiated emission measurement:

- 24.100 GHz.

This frequency has to be measured in a final measurement. The results were presented in the following.

5.3.3 Result final measurement from 9 kHz to 30 MHz

Ambient temperature	11 °C	Relative humidity	72 %
---------------------	-------	-------------------	------

- Position of EUT:** The EUT was set-up on a non-conducting table of a height of 0.8 m. The distance between EUT and antenna was 3 and 10 m.
- Cable guide:** The cable of the EUT was fixed on the non-conducting support. For further information of the cable guide refer to the pictures in annex A of this test report.
- Test record:** The test was carried out in normal operation mode of the EUT. All results are shown in the following.
- Power supply:** During all measurements the EUT was supplied with 24.0 V_{DC} by an external power supply.
- Test results:** The test results were calculated with the following formula:

$$\text{Result [dB}\mu\text{V/m]} = \text{reading [dB}\mu\text{V]} + \text{antenna factor [dB/m]}$$

Results with measuring distance of 3 m						
Frequency MHz	Result dB μ V/m	Limit ²⁾ dB μ V/m	Margin dB	Detector	Readings dB μ V	Antenna factor ¹⁾ dB/m
5.960	31.9	69.5	37.6	QP	11.9	20.0
Results with measuring distance of 10 m						
Frequency MHz	Result dB μ V/m	Limit ²⁾ dB μ V/m	Margin dB	Detector	Readings dB μ V	Antenna factor ¹⁾ dB/m
5.960	Signal was below the noise floor of the measuring system at 10 m distance					
Measurement uncertainty: +2.2 dB / -3.6 dB						

¹⁾: Cable loss included

²⁾: Limits according to [2] and [3] extrapolated with a factor of 40dB/decade according to [2]

Test: Passed

Test equipment used for the test (see chapter 6):

52, 53, 55, 177, 178

5.3.3.1 Final radiated emission measurement (30 MHz to 1 GHz)

Ambient temperature	22 °C	Relative humidity	56 %
---------------------	-------	-------------------	------

Position of EUT: The EUT was setup on a non-conducting table of a height of 0.8 m. The distance between EUT and antenna was 3 m.

Test record: The test was carried out in normal operation mode of the EUT.

Supply voltage: During all measurements the EUT was supplied with 24.0 V_{DC} by an external power supply.

Test results: The test results were calculated with the following formula:

$$\text{Result [dB}\mu\text{V/m]} = \text{reading [dB}\mu\text{V]} + \text{cable loss [dB]} + \text{antenna factor [dB/m]}$$

The results of the standard subsequent measurement on the open area test site are indicated in the table below. The limits as well as the measured results (levels) refer to the above mentioned standard while taking account of the specified requirements for a 3 m measuring distance.

The measurement time with the quasi-peak measuring detector is 5 seconds.

Result measured with the quasi-peak detector:

Spurious emissions inside restricted bands										
Frequency	Result	Limit	Margin	Readings	Antenna factor	Cable loss	Height	Azimuth	Pol.	Pos.
MHz	dB μ V/m	dB μ V/m	dB	dB μ V	dB/m	dB	cm	deg		
174.341	19.5	43.5	24.0	8.1	9.9	1.5	102	29	Vert.	1
309.901	23.1	46.0	22.9	8.3	12.9	1.9	178	32	Vert.	1
426.140	25.8	46.0	20.2	7.4	16.1	2.3	236	132	Hor.	2
466.356	37.6	46.0	8.4	18.5	16.7	2.4	357	181	Vert.	1
655.600	36.2	46.0	9.8	13.7	19.6	2.9	122	210	Hor.	2
Measurement uncertainty				+2.2 dB / -3.6 dB						

Test: Passed

Test equipment used for the test (see chapter 6):

14 - 21

5.3.3.2 Final radiated emission measurement (1 GHz to 110 GHz)

Ambient temperature	22 °C	Relative humidity	61 %
---------------------	-------	-------------------	------

Position of EUT: The EUT was setup on a non-conducting table of a height of 1.5 m. The distance between EUT and antenna was 30 cm.

Test record: The test was carried out in normal operation mode of the EUT.

Supply voltage: During all measurements the EUT was supplied with 24.0 V_{DC} by an external power supply.

Resolution bandwidth: For all measurements a resolution bandwidth of 1 MHz was used.

Test results: The test results were calculated with the following formula:

$$\text{Result [dB}\mu\text{V/m]} = \text{reading [dB}\mu\text{V]} + \text{cable loss [dB]} + \text{antenna factor [dB/m]} - \text{Preamp [dB]} + \text{measuring distance correction factor [dB]}$$

Remark: The worst case position for the emissions listed below is position 1.

Result measured with the peak detector:

Frequency GHz	Result dB μ V/m	Limit dB μ V/m	Margin dB	Readings dB μ V	Antenna factor 1/m	Preamp dB	Cable loss dB	Corr. Factor dB	Height cm	Pol.	Restr. Band
24.100	110.8	148.0	38.2	79.0	37.2	0.0	4.6	-10.0 * ¹	150	Hor.	Carrier
48.200	87.1	108.0	20.9	59.3	44.2	0.0	3.6	-20.0 * ²	150	Hor.	Second harmonic
72.300	70.7	108.0	37.3	44.3	42.8	0.0	3.6	-20.0 * ²	150	Hor.	Third harmonic
Measurement uncertainty							+2.2 dB / -3.6 dB				

*¹: Measuring distance correction factor from 3 m to 1 m according to [2]

*²: Measuring distance correction factor from 3 m to 30 cm according to [2]

Result measured with the average detector:

Frequency GHz	Result dB μ V/m	Limit dB μ V/m	Margin dB	Readings dB μ V	Antenna factor 1/m	Preamp dB	Cable loss dB	Corr. Factor* dB	Height cm	Pol.	Restr. Band
24.100	109.8	128.0	18.2	78.0	37.2	0.0	4.6	-10.0 * ¹	150	Hor.	Carrier
48.200	80.5	88.0	7.5	52.7	44.2	0.0	3.6	-20.0 * ²	150	Hor.	Second harmonic
72.300	64.7	88.0	23.3	36.3	42.8	0.0	3.6	-20.0 * ²	150	Hor.	Third harmonic
Measurement uncertainty							+2.2 dB / -3.6 dB				

*¹: Measuring distance correction factor from 3 m to 1 m

*²: Measuring distance correction factor from 3 m to 30 cm

Test: Passed

Test equipment used for the test (see chapter 6):

29, 31 - 34, 37, 52, 149, 154, 155, 165, 176 - 178

5.4 Conducted emissions on power supply line (150 kHz – 30 MHz)

5.4.1 Method of measurement of conducted emission

This test will be carried out in a shielded chamber. Tabletop devices will set up on a non-conducting support with a size of 1 m by 1.5 m and a height of 80 cm above the ground plane. Floor-standing devices will be placed directly on the ground plane. The setup of the Equipment under test will be in accordance to [1].

The frequency range 150 kHz to 30 MHz will be measured with an EMI Receiver set to MAX Hold mode with peak and average detector and a resolution bandwidth of 9 kHz. A scan will be carried out on the phase (or plus pole in case of DC powered devices) of the AC mains network. If levels detected 10 dB below the appropriate limit, this emission will be measured with the average and quasi-peak detector on all lines.

Frequency range	Resolution bandwidth
150 kHz to 30 MHz	9 kHz

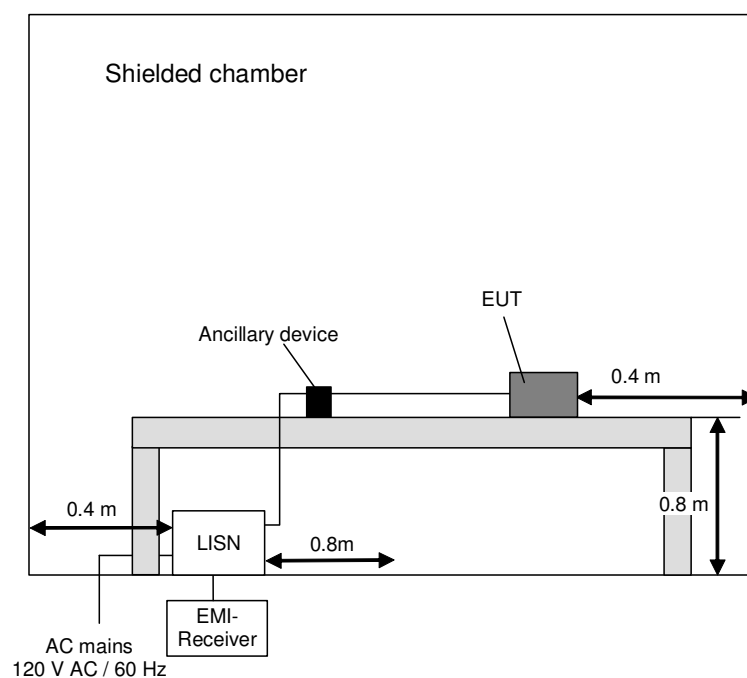

5.4.2 Test results (conducted emission measurement on AC mains, EUT DC supplied)

Ambient temperature	22 °C	Relative humidity	58 %
---------------------	-------	-------------------	------

Position of EUT: The EUT was setup on a wooden table of a height of 0.8 m.

Cable guide: The cable of the EUT was fixed on the wooden table. For further information of the cable guide refer to the pictures in annex A of this test report.

Test record: The test was carried out in normal operation mode of the EUT.

Power supply: During this test the EUT was powered with 24 V_{DC} by the Mini-PS-100-240AC/24DC/1, which was itself supplied with 120 V_{AC} / 60 Hz.

The curves in the diagram only represent for each frequency point the maximum measured value of all preliminary measurements which were made for each power supply line. The top measured curve represents the peak measurement and the bottom measured curve the average measurement. The quasi-peak measured points are marked by **◆** and the average measured points by **+**.

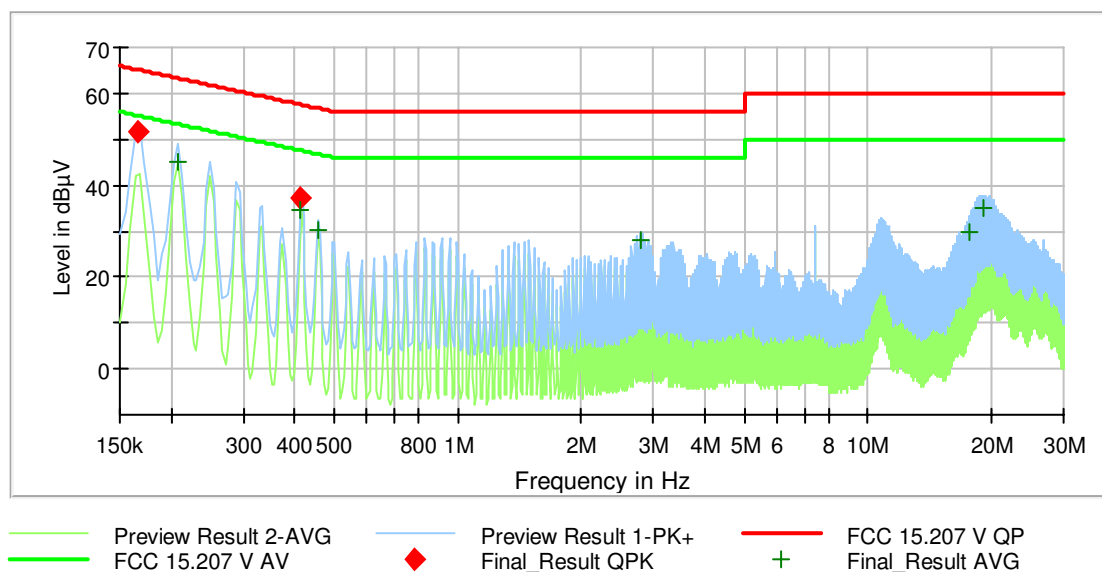

Frequency (MHz)	QuasiPeak (dBµV)	Average (dBµV)	Limit (dBµV)	Margin (dB)	Meas. Time (ms)	Bandwidth (kHz)	Line	PE	Transducer (dB)
0.166200	51.8	---	65.2	13.4	5000.0	9.000	L1	GND	9.8
0.207600	---	45.1	53.3	8.2	5000.0	9.000	L1	FLO	9.9
0.414600	---	34.6	47.6	13.0	5000.0	9.000	L1	FLO	9.9
0.414600	37.1	---	57.6	20.5	5000.0	9.000	L1	GND	9.9
0.456000	---	30.2	46.8	16.6	5000.0	9.000	L1	FLO	9.9
2.778900	---	28.0	46.0	18.0	5000.0	9.000	L1	GND	10.2
17.588400	---	29.7	50.0	20.3	5000.0	9.000	L1	FLO	10.9
19.040100	---	34.9	50.0	15.1	5000.0	9.000	L1	FLO	10.9
Measurement uncertainty			+6.7 dB / -6.0 dB						

Test: Passed

Test equipment used for the test (see chapter 6):

1 - 5 177, 178

5.4.3 Test results (conducted emission measurement on AC mains, EUT AC supplied)

Ambient temperature	22 °C	Relative humidity	58 %
---------------------	-------	-------------------	------

Position of EUT: The EUT was setup on a wooden table of a height of 0.8 m.

Cable guide: The cable of the EUT was fixed on the wooden table. For further information of the cable guide refer to the pictures in annex A of this test report.

Test record: The test was carried out in normal operation mode of the EUT.

Power supply: During this test the EUT was powered with 27 V_{AC} by the B9701089, which was itself supplied with 120 V_{AC} / 60 Hz.

The curves in the diagram only represent for each frequency point the maximum measured value of all preliminary measurements which were made for each power supply line. The top measured curve represents the peak measurement and the bottom measured curve the average measurement. The quasi-peak measured points are marked by **◆** and the average measured points by **+**.

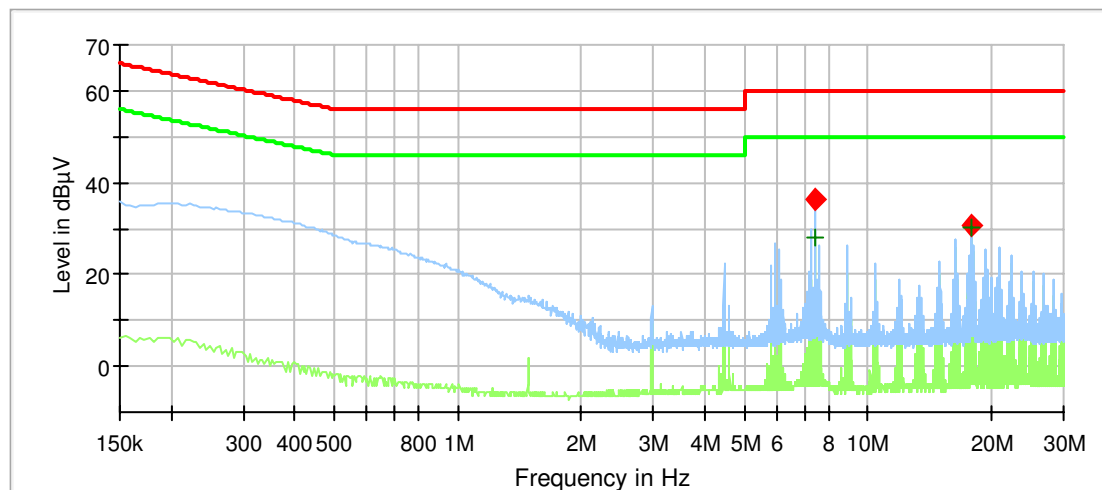

— Preview Result 2-AVG
 — Preview Result 1-PK+
 — FCC 15.207 V QP
— FCC 15.207 V AV
 ◆ Final_Result QPK
 + Final_Result AVG

Frequency (MHz)	QuasiPeak (dBµV)	Average (dBµV)	Limit (dBµV)	Margin (dB)	Meas. Time (ms)	Bandwidth (kHz)	Line	PE	Transducer (dB)
7.436400	36.5	---	60.0	23.5	5000.0	9.000	N	GND	10.5
7.437300	---	28.2	50.0	21.8	5000.0	9.000	N	GND	10.5
17.848500	---	30.3	50.0	19.7	5000.0	9.000	N	GND	10.9
17.849400	30.9	---	60.0	29.1	5000.0	9.000	N	GND	10.9
Measurement uncertainty			+6.7 dB / -6.0 dB						

Test: Passed

Test equipment used for the test (see chapter 6):

1 - 6, 177, 178

6 Test equipment and ancillaries used for tests

No.	Test equipment	Type	Manufacturer	Serial No.	PM. No.	Cal. Date	Cal. due
1	Shielded chamber M4	-	Siemens AG	B83117-S1-X158	480088	Weekly verification (system cal.)	
2	EMI Receiver	ESIB 26	Rohde & Schwarz	1088.7490	481182	02/15/2016	02/2018
3	LISN	NSLK8128	Schwarzbeck	8128161	480138	02/16/2016	02/2018
4	Transient Limiter	CFL 9206A	Teseq GmbH	38268	481982	Weekly verification (system cal.)	
5	EMI Software	EMC32	Rohde & Schwarz	-	481800	-	-
6	Isolating and regulating transformer	B9701089	Block	105713	480341	-	-
14	Open area test site	-	Phoenix Test-Lab	-	480085	Weekly verification (system cal.)	
15	EMI Receiver	ESIB 7	Rohde & Schwarz	1088.7490K07	480521	02/18/2016	02/2018
16	Controller	HD100	Deisel	100/670	480139	-	-
17	Turntable	DS420HE	Deisel	420/620/80	480087	-	-
18	Antenna support	AS615P	Deisel	615/310	480086	-	-
19	Antenna	CBL6111 D	Chase	25761	480894	09/18/2014	09/2017
20	EMI-Software	EMC 32	Rohde & Schwarz	-	481022	-	-
21	6 dB attenuator	R412706000	Radiall	9833	410082	Annual verification	
29	Fully anechoic chamber M20	-	Albatross Projects	B83107-E2439-T232	480303	Weekly verification (system cal.)	
31	Measuring receiver	ESI 40	Rohde & Schwarz	100064	480355	02/16/2016	02/2017
32	Controller	MCU	Maturo	MCU/043/971107	480832	-	-
33	Turntable	DS420HE	Deisel	420/620/80	480315	-	-
34	Antenna support	AS615P	Deisel	615/310	480187	-	-
35	Antenna	CBL6112 B	Chase	2688	480328	04/14/2014	04/2017
36	Antenna	3115 A	EMCO	9609-4918	480183	11/10/2014	11/2017
37	Turn device	TDF 1.5- 10Kg	Maturo	-	482034	-	-
40	Spectrum analyser	FSU46	Rohde & Schwarz	200125	480956	02/17/2016	02/2017
43	RF-cable No. 36	Sucoflex 106B	Suhner	0522/6B	480571	Weekly verification (system cal.)	
44	RF-cable No. 3	Sucoflex 106B	Suhner	0563/6B	480670	Weekly verification (system cal.)	
45	RF-cable No. 40	Sucoflex 106B	Suhner	0708/6B	481330	Weekly verification (system cal.)	
49	Preamplifier	JS3-00101200-23-5A	Miteq	681851	480337	Six month verification (system cal.)	
52	Power supply	TOE 8752	Toellner	31566	480010	-	-
53	Outdoor test site	-	Phoenix Testlab	-	480293	-	-
55	Loop antenna	HFH2-Z2	Rohde & Schwarz	100417	481912	09/15/2015	09/2016
146	Standard Gain Horn 11.9 GHz – 18 GHz	18240-20	Flann Microwave	483	480294	Six month verification (system cal.)	
149	Standard Gain Horn 17.9 GHz – 26.7 GHz	20240-20	Flann Microwave	410	480296	Six month verification (system cal.)	

No.	Test equipment	Type	Manufacturer	Serial No.	PM. No.	Cal. Date	Cal. due
150	Standard Gain Horn 26.4 GHz – 40.1 GHz	22240-20	Flann Microwave	469	480299	Six month verification (system cal.)	
153	Harmonic mixer with Standard Gain Horn 40 GHz – 60 GHz	FZ-Z60 / 24240-20	Rohde & Schwarz / Flann Microwave	100071 / 133313	480481	Six month verification (system cal.)	
154	Harmonic mixer with Standard Gain Horn 50 GHz – 75 GHz	FS-Z75 / 25240-20	Rohde & Schwarz / Flann Microwave	100045 / 135181	480480	Six month verification (system cal.)	
155	Harmonic mixer with Standard Gain Horn 75 GHz – 110 GHz	FS-Z110 / 27240-20	Rohde & Schwarz / Flann Microwave	100049 / 138294	480482	Six month verification (system cal.)	
159	Preamplifier	JS3-12001800- 16-5A	Miteq	571667	480343	02/18/2016	02/2018
160	Preamplifier	JS3-18002600- 20-5A	Miteq	658697	480342	02/17/2016	02/2018
161	Preamplifier	JS3-26004000- 25-5A	Miteq	563593	480344	02/18/2016	02/2018
165	RF-cable 1m	KPS-1533-400- KPS	Insulated Wire	-	480300	Six month verification (system cal.)	
176	Multimeter	971A	Hewlett Packard	JP39009358	480721	01/19/2016	01/2017
177	CAN to fibre optics converter	Optocan 2000	SonTec electronic	-	481877	-	-
178	CAN to fibre optics converter	Optocan 2000	SonTec electronic	-	481878	-	-

7 Report history

Report Number	Date	Comment
F160532E1	02/01/2017	Document created

8 List of annexes

Annex A Test setup photographs 11 pages

160532_100.jpg: MWD BPC-HU, test setup fully anechoic chamber
 160532_102.jpg: MWD BPC-HU, test setup fully anechoic chamber (pos. 1)
 160532_101.jpg: MWD BPC-HU, test setup fully anechoic chamber (pos. 2)
 160532_103.jpg: MWD BPC-HU, test setup fully anechoic chamber <1 GHz
 160532_104.jpg: MWD BPC-HU, test setup fully anechoic chamber <1 GHz
 160532_105.jpg: MWD BPC-HU, test setup fully anechoic chamber >1 GHz
 160532_106.jpg: MWD BPC-HU, test setup fully anechoic chamber >1 GHz
 160532_107.jpg: MWD BPC-HU, test setup outdoor test site
 160532_109.jpg: MWD BPC-HU, test setup open area test site
 160532_111.jpg: MWD BPC-HU (DC supplied), test setup shielded room
 160532_112.jpg: MWD BPC-HU (AC supplied), test setup shielded room

Annex B External photographs 3 pages

160532_a.jpg: MWD BPC-HU, 3D-view 1
 160532_b.jpg: MWD BPC-HU, 3D-view 2
 160532_c.jpg: MWD BPC-HU, type plate view

Annex C Internal photographs 8 pages

160532_4.jpg: MWD BPC-HU, internal view 1
 160532_5.jpg: MWD BPC-HU, internal view 2
 160532_7.jpg: MWD BPC-HU, PCB, top view
 160532_9.jpg: MWD BPC-HU, PCB, top view, radar module removed
 160532_8.jpg: MWD BPC-HU, PCB, bottom view
 160532_11.jpg: MWD BPC-HU, radar module, top view
 160532_10.jpg: MWD BPC-HU, radar module, bottom view
 160532_12.jpg: MWD BPC-HU, radar module, shielding removed