

# **Instruction manual**

## **Digital Radar Motion Detector with Infrared Remote Control**

**MWD BF**

**FEIG**  
**ELECTRONIC**

**FEIG ELECTRONIC GmbH Lange Straße 4 35781 Weilburg/Lahn**

22.08.02

## General

© Copyright 2002 by

**FEIG ELECTRONIC GmbH**  
Lange Straße 4  
D - 35781 Weilburg

The indications made in these operating instructions may be altered without previous notice. With the edition of these instructions, all previous editions become void.

Composition of the information given in this manual has been done to the best of our knowledge. FEIG ELECTRONIC does not guarantee the correctness of the details given in these instructions and may not be held liable for damages ensuing from incorrect installation.

Since, despite of all our efforts, errors may not be completely avoided, we are always grateful for your useful tips.

The installation instructions given in this manual are based on advantageous boundary conditions. FEIG ELECTRONIC does not give any guarantee promise for perfect function of the traffic detector in a cross surrounding.

Copy or reproduction of these instructions, even if only partial, as well as translation into other languages is forbidden unless a written consent has been granted by FEIG ELECTRONIC. This also applies to the complete or partial storage of these operating instructions on modern input- and output media for further processing in data processing systems.

***Please read the operating- and safety instructions thoroughly before putting the motion detector into operation!!***

## Contents

<b>FUNCTIONAL DESCRIPTION</b> .....	<b>4</b>
<b>2 INSTALLATION</b> .....	<b>5</b>
2.1 Place of installation.....	5
2.2 Mounting of the bracket.....	5
2.3 How to connect the motion detector .....	5
2.4 How to screw down the housing .....	5
<b>3 ADJUSTMENT AND INITIATION</b> .....	<b>7</b>
3.1 Direction identification.....	7
3.2 Device address .....	8
3.3 LED display .....	8
3.4 Fall-delay time of relay .....	8
3.6 Adjustment with key buttons.....	9
3.6.1 Selection of sensitivity .....	9
3.6.2 Personal suppression.....	9
3.6.3 Factory setting.....	9
3.7 Adjustments with the infrared remote control MWD RC.....	9
3.7.1 How to activate the adjustment mode .....	9
3.7.2 Selection of sensitivity .....	10
3.7.3 Personal suppression.....	10
3.7.4 How to terminate the adjustment mode.....	10
3.8 Adjustment of the detection zone .....	10
3.9 Initiation procedure .....	11
3.10 Possible reasons of malfunctions.....	11
<b>5 SAFETY INSTRUCTIONS</b> .....	<b>13</b>
<b>6 TYPE APPROVAL</b> .....	<b>14</b>
<b>7 ABSTRACT</b> .....	<b>16</b>

## Functional description

The MWD BF is a radar motion detector with direction identification, which has been especially designed for applications in the area of industrial gate- and barrier systems. In some cases, the operational parameters may also be adjusted with an infrared remote control.

Motion detection is done according to the Doppler's principle. The sensor sends out 24 GHz microwaves. These microwaves are reflected by objects in motion and thus their frequency changes. The sensor receives these altered frequencies and analyses them. Thus, each motion within the detection range is recorded, analysed by a logic and transmitted to the gate- resp. barrier control by connecting potential-free change-over contacts.

### Range of application:

Entry-/access recognition for the drive of industrial gate- and barrier systems

### Special features:

- Insensitive to fluctuations of temperature and humidity
- Distinction vehicles/persons
- Reversible and cutoff direction logic
- Adjustable sensitivity
- Potential-free relay exit with change-over contacts
- Large supply voltage range - AC or DC
- Adjustment of operational parameters by key buttons or infrared remote control
- Compact plastic housing
- IP 65 housing
- Easy and fast installation with mounting bracket

## 2 Installation

### 2.1 Place of installation

The device is centrally mounted above the area to be monitored. Both wall- and ceiling mounting are possible. The maximum mounting height is approx. 6m.

#### **Hints for planning and installation:**

- The device has to be mounted *vibrationless*.
- In order to avoid incorrect release, there must not be *any objects in motion within the radiation field*.
- There must not be *any fluorescent tubes* within the radiation field of the detector.
- It should be avoided that the radiation fields of two motion detectors overlap, since this may lead to incorrect releases.
- Do not install behind objects, building coverings or elements.
- If the motion detector is exposed to rain or snow, it should be adjusted to directional recognition.
- If *conductive floors* are used and the radiation direction is almost vertical, incorrect releases may be caused by reflections.

### 2.2 Mounting of the bracket

The bracket is suitable for both wall- and ceiling mounting. In case of ceiling mounting, it has to be turned by 180° opposite the housing of the motion detector.

### 2.3 How to connect the motion detector

Connection is done as shown in figure 2. Deposit the leads of the flexible connecting cable 10 cm from the appliance, lead it through the lateral PG-screwing and fix it. In case of DC power supply, polarity is insignificant.

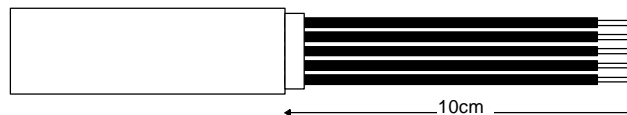

### 2.4 How to screw down the housing

The cover should be screwed down with a torque of approx. 1 Nm. Put the cover evenly into the groove of the housing and screw it down.

**Attention!** *If the cover is tilt, for example due to squeezed cable leads in between the screw guides, the tightness of the housing is not guaranteed!*

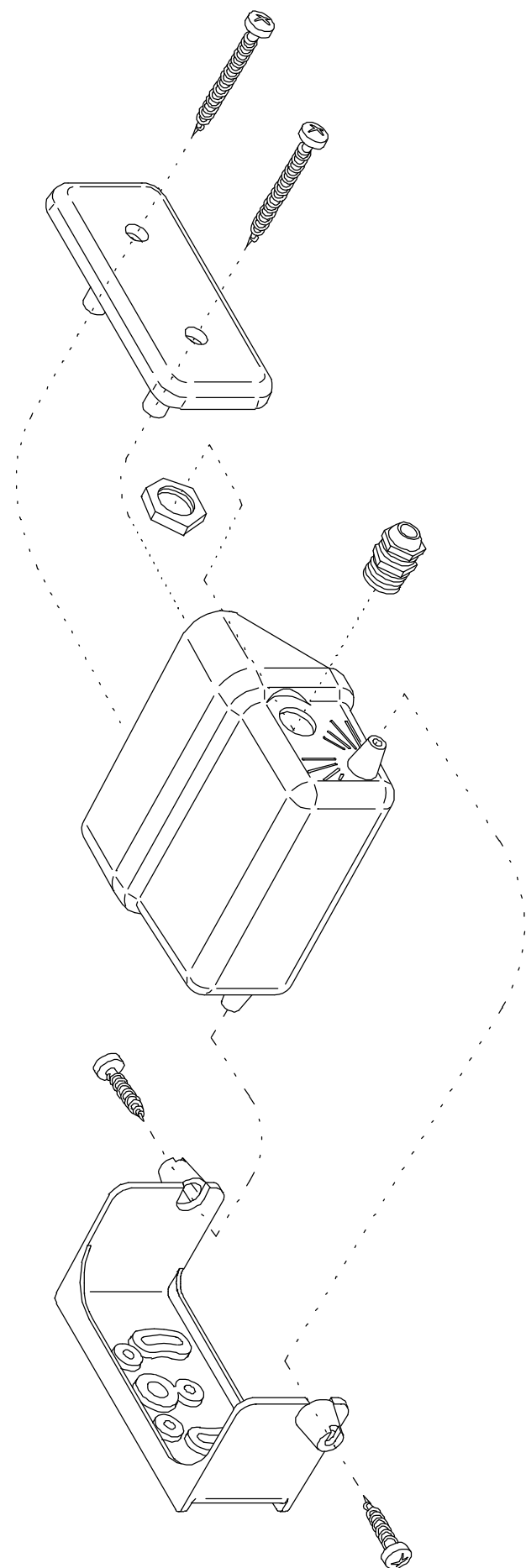

**Figure 1: Magnified diagram of the housing.**

### 3 Adjustment and Initiation

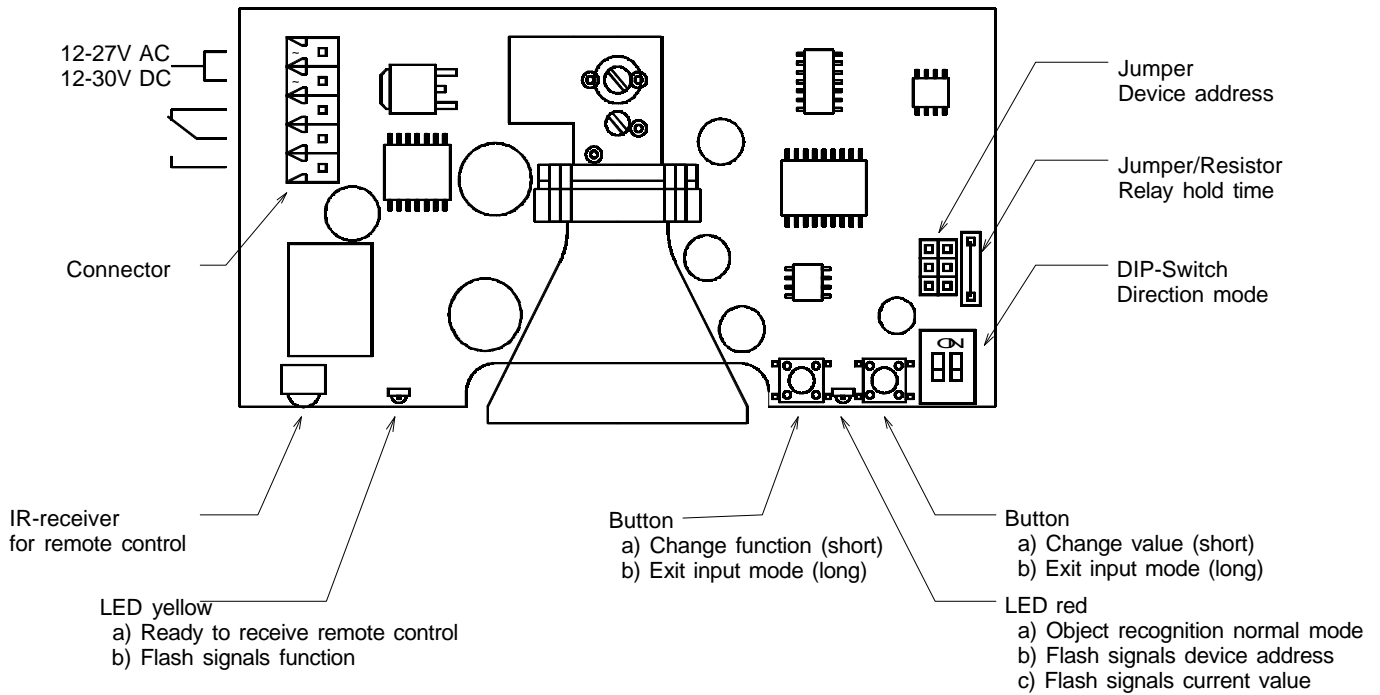





Figure 2: Operating elements on PCB





#### 3.1 Direction identification

The direction identification device of the motion detector may be adjusted by the DIP-switches located on the right side. DIP-switch No. 1 is assigned to *approaching* objects, which is adjusted most often. If DIP-switch No. 2 is switched on, the device reacts to objects that are *departing from* the motion detector. If both DIP-switches are switched on or off, the direction identification is deactivated.

Direction identification	DIP-switch	
	1	2
<i>approaching</i>		ON OFF
departure		OFF ON
off		OFF OFF
		ON ON

### 3.2 Device address

In order to be able to adjust neighboring motion detectors with a remote control, an address may be assigned to each device in the range of 1-4. For this purpose, a jumper field is located above the DIP-switches.

Address	Jumper position
1	
2	
3	
4	

### 3.3 LED display

Mode of operation	Yellow LED – left side	Red LED – right side
object recognition	off	object identified
adjustment with key button	flash signals for function numbers	flash signals acc. to parameter significance
adjustment with remote control	a) ready to receive infrared remote control b) flash signals for function numbers	a) flash signals acc. to parameter significance b) flash signals for device address

### 3.4 Fall-delay time of relay

The factory-alignment for the fall-delay time of the relay is 0,5 seconds.

An extension of the fall-delay time to 2 seconds may be reached by removing the resistor which is located next to the jumpers for the device address (figure 2).

**Warning:** *The resistor may only be cut through in power off condition !  
Please make sure that no components or strip conductors are damaged !*

### 3.5 Personal suppression

If personal suppression is activated, the appearance of single persons will not trigger the device. For more information regarding adjustment of personal suppression, please see section 3.6.2 resp. 3.7.3.

Personal suppression is designed for the use in typical internal traffic situations at a shed gate. Deviating conditions (very low or high mounting height, setting angle is too steep or too flat, oblique mounting position) or untypical objects (e.g. fast moving persons, groups, very slow



vehicles, fork-lift trucks with fabric rolls etc.) may lead to malfunctions if personal suppression is activated.

### 3.6 Adjustment with key buttons

Operational parameters (sensitivity, personal suppression) may be adjusted with the buttons located at the right side of the horn antenna.

<i>Left button / yellow LED:</i>	<i>select/indicate function</i>
<i>Right button / red LED:</i>	<i>change/indicate value</i>

If a function is selected for the first time, the function number is indicated on the yellow LED , followed by the currently set value on the red LED.

The adjustment process is terminated automatically 30 seconds after the last button has been pressed or by pressing a button for a longer time.

#### 3.6.1 Selection of sensitivity

The sensitivity of the motion detector may be adjusted in the range of 1 to 15. Each time the right button is pressed, the sensitivity is increased by one degree. Degree 15 is followed by degree 1.

<i>Yellow LED</i>	<i>flashes</i>	<i>1x</i>
<i>Red LED</i>	<i>flashes</i>	<i>1 x acc. to value of the current degree of sensitivity</i>

#### 3.6.2 Personal suppression

The personal suppression of the motion detector may be activated (position 1) and deactivated (position 2) by using the button on the right side.

<i>Yellow LED</i>	<i>flashes</i>	<i>2x</i>
<i>LED rot</i>	<i>flashes</i>	<i>1x if personal suppression is activated</i> <i>2x if personal suppression is deactivated</i>

#### 3.6.3 Factory setting

In order to reset the parameters to the factory setting, both buttons are pressed while switching on power supply. Now, the following adjustments are made:

<i>Degree of sensitivity:</i>	<i>7</i>
<i>Personal suppression:</i>	<i>off</i>

### 3.7 Adjustments with the infrared remote control MWD RC

#### 3.7.1 How to activate the adjustment mode

Before the parameters of a motion detector can be changed with the remote control, the device has to be activated for this adjustment. For this purpose, please press the  -key. Now, all motion detectors within the range of reception of the remote control will indicate the set device address on the red LED. If the address of the desired device is entered within 3 seconds by the numeral keys of the remote control, the activated device shows its readiness for entry on the yellow LED. All other devices are not activated and return to their normal mode.

### 3.7.2 Selection of sensitivity

After the device has been cleared, the sensitivity of the motion detector may be changed with the keys ◀ and ▶ . When the keys are pressed for the first time, the yellow LED indicates the number of the desired function with flash signals. The adjusted value is indicated by flash signals of the red LED. Sensitivity ranges from 1 to 15.

Yellow LED	flashes	1x	(function 1)
Red LED	flashes	1 x acc.	to value of current sensitivity level

Notice: Please switch off personal suppression when adjusting sensitivity.

### 3.7.3 Personal suppression

The  -key changes the setting of the personal suppression.

Yellow LED	flashes	2x	(function 2)
Red LED	flashes	1x	if personal suppression is switched on
		2x	if personal suppression is switched off

### 3.7.4 How to terminate the adjustment mode

Adjustment with the remote control is terminated by pressing the  -key. The motion detector now returns to the normal detection mode. The yellow LED is extinguished. The red LED now continues to indicate detected objects. The object recognition mode is automatically activated, if no entry has been made with the key buttons or remote control for 30 seconds.

## 3.8 Adjustment of the detection zone

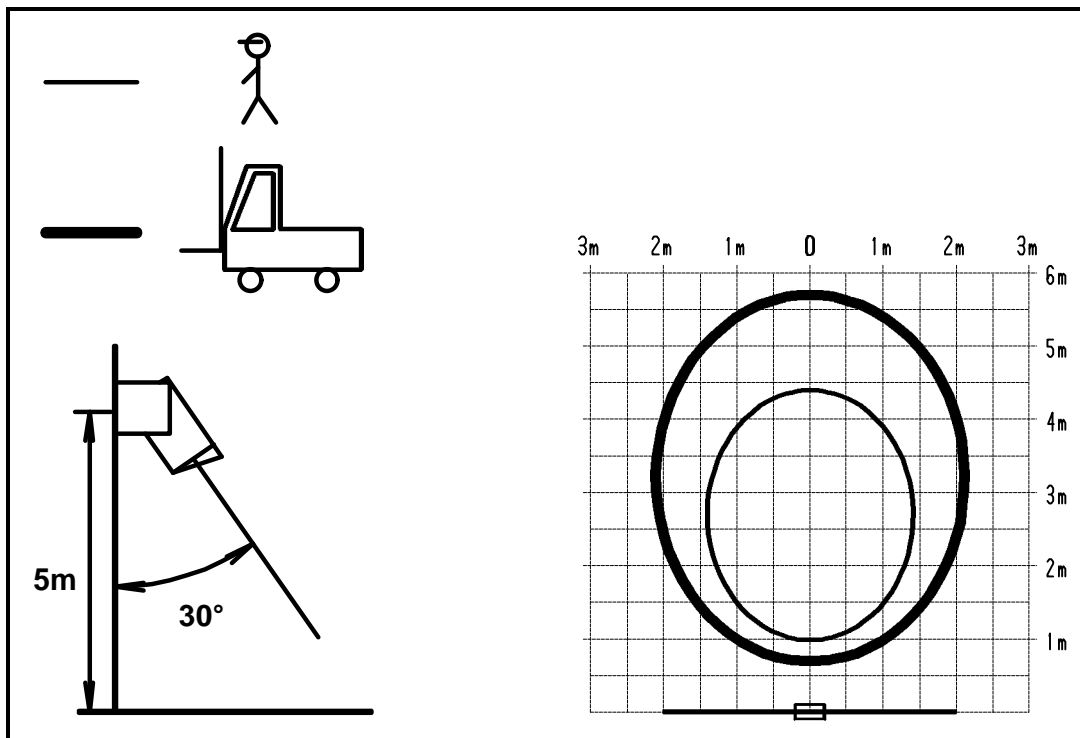

The MWD BF has a circular detection zone. Size and position of the detection zone may be altered by adjusting sensitivity and inclination angle. In general, the optimum inclination angle lies between 30° and 45°.

In order to change the angle of radiation, please loosen the lateral screws located between mounting bracket and housing. On both sides of the housing there are division marks in a 15° grid system.

The size of the detection zone may change depending on the size and speed of the object to be detected. If the motion detector is mounted in a height of more than 4 meters and sensitivity is low, the detection zone for persons becomes very small.

### 3.9 Initiation procedure

- Sensitivity adjustment should always be done with the personal suppression mode being switched off. If need be, the personal suppression mode may then be activated and the function may be tested with a vehicle ( $v > 10\text{km/h}$ ).
- The first attempts of putting the device into operation should be carried out with the opening system of the downstream gate- or barrier system being switched off. The personal suppression mode should be switched off as well.
- In order to test the device, please approach the motion detector from one point outside the detection field and observe the reaction of the device by means of the LED. This test should be carried out from all directions.
- With the help of the information gained by this test, the detection zone of the motion detector may be changed by using the sensitivity adjustment.
- The gate- resp. barrier control may now be put into operation again. After that, one trial run should be carried out with the gate operating. If the motion detector reacts to the movements of the gate, the inclination angle to the gate has to be increased, until this effect may not be noticed anymore.
- If need be, the size of the detection zone has to be readjusted by using sensitivity selection.

### 3.10 Possible reasons of malfunctions

- The reasons for malfunctions of the motion detector may be the following
  - moving parts in the surrounding area,
  - vibrations which are transmitted to the appliance through the mounting bracket,
  - electric disturbances in the connecting cable
  - or electric fields

## 4 Technical Data

<b>Housing</b>	Dimensions (without cable) 132 x 155 x 58 mm Color black Housing plastic ASA Mounting bracket plastic ASA Cover plastic PC
<b>Weight (incl. mounting bracket)</b>	0,3 kg
<b>Protective system</b>	IP 65
<b>Supply voltage</b>	12-27 V AC 12-30 V DC
<b>Power consumption</b>	typ. 1,5 W max. 2,4 W
<b>Operating temperature</b>	-20 °C to +55 °C
<b>Storing temperature</b>	-30 °C to +75 °C
<b>Air moisture</b>	< 95 % non fogging
<b>Frequency</b>	24,125 GHz
<b>Transmitting power</b>	typ. 5 mW
<b>Output relay</b>	
max. turn-on voltage	24 V AC/DC
max. switching current	1 A at resistive load
min. switching current	1 mA
Contact type	1 change-over contact (potential-free) In case of inductive load please provide for an external protective wiring or the relay contacts !
<b>Connecting cable</b>	Flexible, max. 5x1,0 qmm
<b>Fall-delay time of relay</b>	0,5 s / 2 s , selection with jumper
<b>Maximum mounting height</b>	6 m
<b>Adjustable functions</b>	By means of sliding switch on printed card Direction recognition off/approaching/departure  By means of key button or infrared remote control Sensitivity Personal suppression Factory setting (only key buttons)
<b>Applicable standards</b>	
Radio approval	ETS 300 440 FCC CFR 47, Part 15 Subpart C, Section 15.245
EMC	ETS 300 683

## 5 Safety instructions

- This device shall only be used for the purpose intended by the manufacturer.
- The operating instructions have to be handed out to each user and accessible at any time.
- Improper changes and spare parts resp. special features which are not sold or recommended by the manufacturer of the device may cause fires, electric shock and injuries. Such measures therefore lead to nonliability of the manufacturer and no guarantee will be given.
- For this device, the warranty regulations act applies in the version valid at the time of purchase. We exclude liability for improper or wrong manual or automatic adjustment of parameters resp. improper use of the appliance.
- Repair work should only be carried out by the manufacturer.
- Connection, initiation, maintenance, measuring and adjustment of the motion detector should only be carried out by electrical engineers with accident prevention skills.
- When handling appliances which get into contact with electric current, VDE-rules have to be observed - especially VDE 0100, VDE 0550/0551, VDE 0700, VDE 0711, VDE 0860, VDE 0105 as well as the fire – and accident prevention standard VBG4.
- Please switch off current supply prior to opening the device and make sure that it remains off.
- If an indicator lamp goes out, this is not a proof that the device is without electricity and disconnected from power supply. All work that is carried out at the device as well as installation has to be carried out in conformance with the national electric regulations and the local rules.
- The user has to make sure that the appliance is mounted and connected according to the technical rules of the country of installation as well as other regional regulations. This applies especially to cable dimensioning, protection, earthing, cutoff, disconnection, isolation supervision and excess current cut-out.
- Low-voltage operation is not allowed at the relay outputs.
- According to machine rule 89/392/EWG, appendix IV, the device may not be used as a *safety component*. In facilities with a high danger potential, additional safety devices are necessary !
- The hard gold alloy of the relay contacts is destroyed if switching currents of more than 100 mA are used. Relays with such predamaged contacts may only switch currents of more than 100 mA reliably!
- If the place of operation is located in direct proximity to foil gates, suitable measures have to be taken to branch off the electrostatic charging of the gate foil.

## 6 Type approval

### Europe (CE)

When used according to regulation, this radio equipment conforms with the basic requirements of article 3 and the other relevant provisions of the R&TTE guideline 1999/5/EC dated March 99.

# CETECOM ICT Services GmbH

## EC Identification number 0682

authorized by the German Government



with decree Vfg 28/2000, issued in the Official Journal 6/2000  
of the Regulierungsbehörde für Telekommunikation und Post,  
to act as Notified Body in accordance with the R&TTE Directive 1999/5/EC of 09. March 1999.

### CERTIFICATE EXPERT OPINION

Registration-No.:	<b>E811674M-EO</b>
Certificate Holder:	<b>FEIG ELECTRONIC GmbH</b>
	<b>Lange Str. 4 D-35781 Weilburg-Waldhausen</b>
Product Designation:	<b>MWD BF</b>
Product Description:	<b>Radar Movement Detector</b>
Product Manufacturer:	<b>FEIG ELECTRONIC GmbH</b>
	<b>Lange Str. 4 D-35781 Weilburg-Waldhausen</b>

Essential requirements	Specifications / Standards	Submitted documents	Result
Radio spectrum (R&TTE, Article 3.2)	ETSI I-ETS 300 440 (1995-12) BAPT 211 ZV 3/2099(1994-04)	Test Report Approval Certificate G115672E	conform

Marking: **The product shall be signed with CE, our notified body number and the Class II identifier (Alert sign) as shown right hand.**

CE 0682 ⓘ

The scope of this evaluation relates to the submitted documents only.  
The certificate is only valid in conjunction with the following **number** of annexes.

Number of annexes: **1**

Saarbrücken, 07.12.2000  
Place, Date of Issue

  
 Signed by Lothar Spitzer  
 Notified Body



---

CETECOM ICT Services GmbH, Untertürkheimer Straße 6-10, D-66117 Saarbrücken, Germany  
<http://www.cetecom.de>

**USA (FCC)****FCC ID: PJMMWDBF**

This device complies with part 15 of the FCC Rules. Operation is subject to the following two conditions:

- (1) This device may not cause harmful interference, and
- (2) this device must accept any interference received, including interference that may cause undesired operation.

Unauthorized modifications may void the authority granted under Federal communications Commission Rules permitting the operation of this device.

# 7 Abstract

## Operating elements and pin configuration:

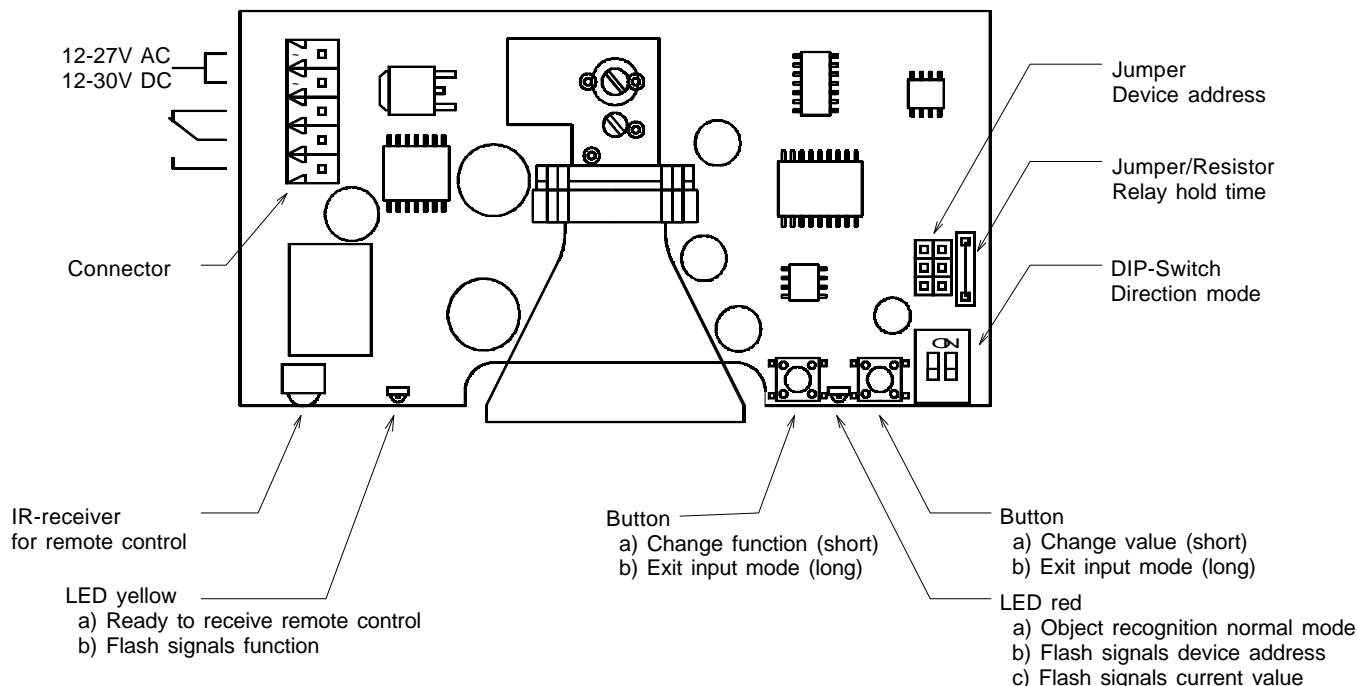

Direction recognition	DIP-switches	
	1	2
Off		OFF OFF
		ON ON
Approaching		ON OFF
Departure		OFF ON

Device address for remote control	Jumper position
1	
2	
3	
4	

Remote control key	Function	Flash signal of LED		Adjustment range
		Left	right	
	Activation	Ready	Address	1 .. 4 (address)
	Sensitivity	1x	current value	1=low .. 15=high
	personal suppression	2x	current value	1=on 2=off
<b>i</b>	-	-	-	-