

INTEGRATION

ID ISC.LRM1002-E

Long Range Reader Modul

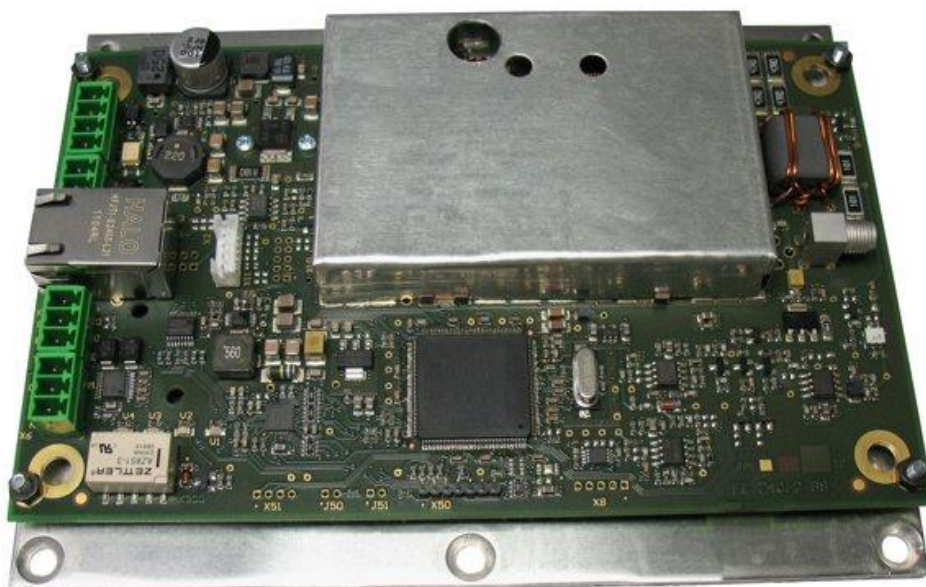

Note

© Copyright by
FEIG ELECTRONIC GmbH
Industriestraße 1a
D-35781 Weilburg (Germany)
Tel.: +49 6471 3109-0
<http://www.feig.de>
identification-support@feig.de

With the edition of this document, all previous editions become void. Indications made in this manual may be changed without previous notice.

Copying of this document and giving it to others and the use or communication of the contents thereof are forbidden without express authority. Offenders are liable to the payment of damages. All rights are reserved in the event of the grant of a patent or the registration of a utility model or design.

Composition of the information in this document has been done to the best of our knowledge. FEIG ELECTRONIC GmbH does not guarantee the correctness and completeness of the details given in this manual and may not be held liable for damages ensuing from incorrect or incomplete information. Since, despite all our efforts, errors may not be completely avoided, we are always grateful for your useful tips.

The instructions given in this manual are based on advantageous boundary conditions.

FEIG ELECTRONIC GmbH does not give any guarantee promise for perfect function in cross environments and does not give any guarantee for the functionality of the complete system which incorporates the subject of this document.

FEIG ELECTRONIC GmbH calls explicit attention that devices which are subject of this document are not designed with components and testing methods for a level of reliability suitable for use in or in connection with surgical implants or as critical components in any life support systems whose failure to perform can reasonably be expected to cause significant injury to human health. To avoid damage, injury or death the user or application designer must take reasonably prudent steps to protect against system failures.

FEIG ELECTRONIC GmbH assumes no responsibility for the use of any information contained in this document and makes no representation that they are free of patent infringement. FEIG ELECTRONIC GmbH does not convey any license under its patent rights nor the rights of others.

Content

1	Safety Instructions	4
2	Performance Features of Reader Family ID ISC.LRM1002	5
2.1	Performance Features.....	5
2.2	Available Reader Types	5
3	Installation and mounting	6
3.1	Mounting ID ISC.LRM1002-E.....	6
3.2	Terminals	7
3.2.1	Antenna connection.....	8
3.2.2	Supply voltage.....	11
3.2.3	OptocouplerInputs (X5 / IN1).....	12
3.2.4	Relay (X6 / REL1)	15
3.2.5	Output 24V $\overline{\text{---}}$ (X5 / VIN, GND).....	17
3.3	Interfaces	18
3.3.1	RS232-Interface X4.....	18
3.3.2	USB – Interface X11 (Host Communication)	19
3.3.3	Ethernet-Interface on X3 (10/100 Base-T).....	20
4	Operating and Display Elements	21
4.1	LEDs	21
5	Radio Approvals	22
5.1	Declaration of Conformity (CE), (UKCA), (USA), (Canada)	22
5.2	USA (FCC) and Canada (IC)	23
5.2.1	Label Information Reader Modul ID ISC.LRM1002-E	24
5.2.2	USA (FCC) and Canada (IC) approved antennas.....	24
6	Technical Data	25

1 Safety Instructions

- ▶ The device may only be used for the intended purpose designed by for the manufacturer.
- ▶ The operation manual should be conveniently kept available at all times for each user.
- ▶ Unauthorized changes and the use of spare parts and additional devices which have not been sold or recommended by the manufacturer may cause fire, electric shocks or injuries. Such unauthorized measures shall exclude any liability by the manufacturer.
- ▶ The liability-prescriptions of the manufacturer in the issue valid at the time of purchase are valid for the device. The manufacturer shall not be held legally responsible for inaccuracies, errors, or omissions in the manual or automatically set parameters for a device or for an incorrect application of a device.
- ▶ Repairs may only be executed by the manufacturer.
- ▶ Installation, operation, and maintenance procedures should only be carried out by qualified personnel.
- ▶ Use of the device and its installation must be in accordance with national legal requirements and local electrical codes.
- ▶ When working on devices the valid safety regulations must be observed.
- ▶ Before touching the device, the power supply must always be interrupted. Make sure that the device is without voltage by measuring. The fading of an operation control (LED) is no indicator for an interrupted power supply or the device being out of voltage!
- ▶ Special advice for wearers of cardiac pacemakers:
Although this device doesn't exceed the valid limits for electromagnetic fields you should keep a minimum distance of 25 cm between the device and your cardiac pacemaker and not stay in the immediate proximity of the device's antenna for any length of time.

2 Performance Features of Reader Family ID ISC.LRM1002

2.1 Performance Features

The Reader has been developed for reading passive data carriers, so-called „Smart Labels“, using an operating frequency of 13.56 MHz. For the operation it is necessary to connect a appropriate external antenna to the connector ANT1.

2.2 Available Reader Types

The following Reader type's are currently available:

Reader type	Description
ID ISC.LRM1002-E	Module version with RS232 / USB / LAN-Interface
ID ISC.LR1002-E	Housing version with RS232 / USB / LAN-Interface

Table 1: Available Reader types

3 Installation and mounting

3.1 Mounting ID ISC.LRM1002-E

The Reader Module is designed for installation on a heat sink. Mounting is accomplished using the $\varnothing 4.5$ mm holes located on the base plate (see: Figure 1).

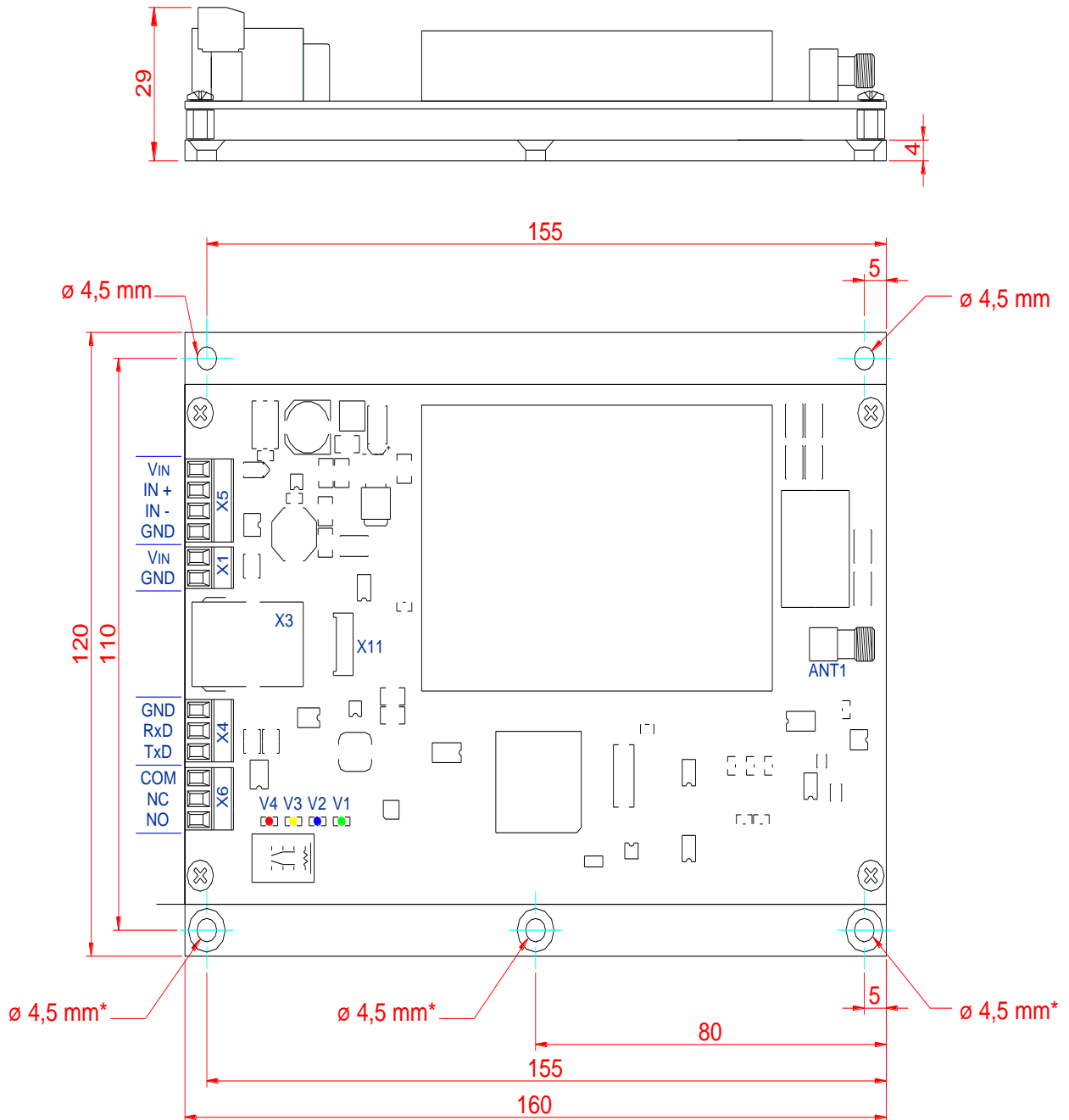

Figure 1: Scale drawing off the Reader module ID ISC.LRM1002-E with mounting plate

To fully exploit the performance of the Reader Module, the heat sink should have a thermal resistance R_{ThK} of max. 2 K/W. When attaching the Reader Module to the heat sink you should strive for a little heat transfer resistance between the base plate and the heat sink as possible. The use of heat sink compound is recommended.

If the antenna is properly tuned and there is sufficient air convection along the mounting plate, the ID ISC.LRM1002-E can be operated without an additional heat sink at up to 2W of power. Note here however that detuning of the antenna can result in additional heating of the Reader. In such cases the Reader regulates its output power down until the upper temperature limit of its final stage fallen down again.

3.2 Terminals

Figure 2 shows the terminals and control elements of the ID ISC.LR(M)1002-E

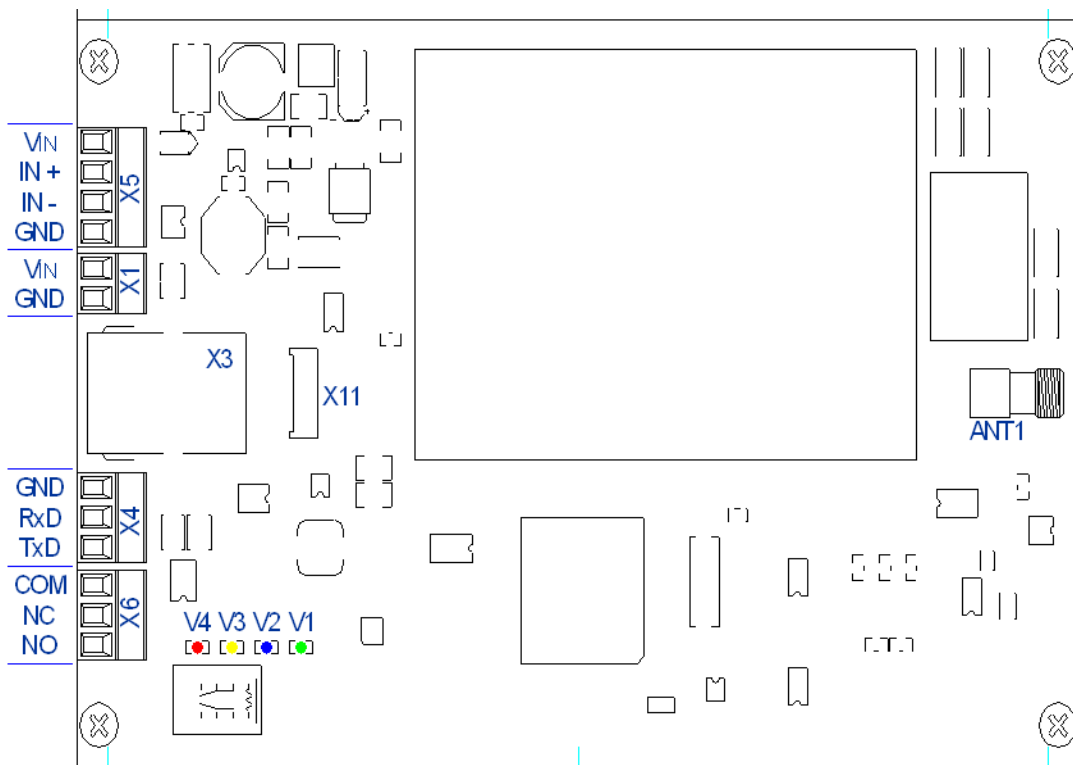

Figure 2: Reader terminals

3.2.1 Antenna connection

The SMA socket „ANT1“ is located on the circuit board for connecting the antenna to the ID ISC.LRM1002.

A external LED can also be supplied with 6,5 V $\overline{\text{---}}$ through the antenna terminal.

This can be controlled by software. The maximum current draw is then not allowed to exceed 20mA.

The voltage is not sufficient to support the dynamic antenna tuning board ID ISC.DAT

See:

[Connection of a ID ISC.DAT \(Dynamic Antenna Tuning Board\)](#)

The maximum tightening torque for the SMA socket is 0.45 Nm (4.0 lbf in).

Attention:

Exceeding the tightening torque will destroy the socket.

Terminal	Description
ANT1	For connecting the antenna (Input Impedance 50Ω)

Table 2: Antenna jack

- The standing wave ratio VSWR for the antenna should not exceed a value of 1,3.
- For reaching optimal read ranges the coaxial cables between readers and antenna must have defined lengths. For all antennas of the company FEIG ELECTRONICS GmbH and for all antennas which with the tuning boards (e.g. ID ISC.DAT, ID ISC.MAT b and ID ISC.MAT s) of FEIG ELECTRONICS GmbH is made the optimal length of the coaxial cable is 1.35 m (Article No. 1654.004.00.00, Name ID ISC.ANT.C-B). See also Mounting Manual Power Splitter ID ISC.ANT.PS-B and ID ISC.ANT.MUX.
- The optimum operating Q factor of the antenna should be in a range of $Q_{oper} = 10...30$. To determine the operating Q the antenna must be supplied with a 50 Ohm source such as a network analyzer or frequency generator.
- To prevent external coupled noise, the antenna cable must be fitted with a EMC ferrite ring core \varnothing 28 mm x 20 mm. The antenna line must be wound around the ring core for at least 4 turns. The distance between the Reader termination and the ring core should be maximum 10 cm (see Figure 3).
- When connecting an antenna, ensure that it does not exceed the permissible limits prescribed by the national regulations for radio frequency devices.



Figure 3: Antenna line with EMC ring cores

3.2.1.1 Connection of a ID ISC.DAT (Dynamic Antenna Tuning Board)

For tuning a ID ISC.DAT tuning board a DC voltage is required. This DC voltage must be provided via a power splitter (ID ISC.ANT.PS-B) or a antenna multiplexer (ID ISC.ANT.MUX)

Figure 4 shows the DC supply of the ID ISC.DAT with a power splitter.

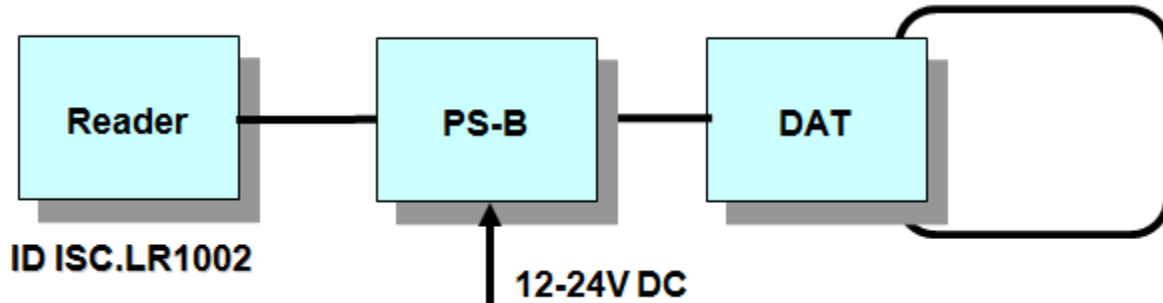

Figure 4: DC supply of a ID ISC.DAT using a power splitter ID ISC.ANT-PS-B

Figure 5 shows the DC supply of the ID ISC.DAT with a Antenna Multiplexer.

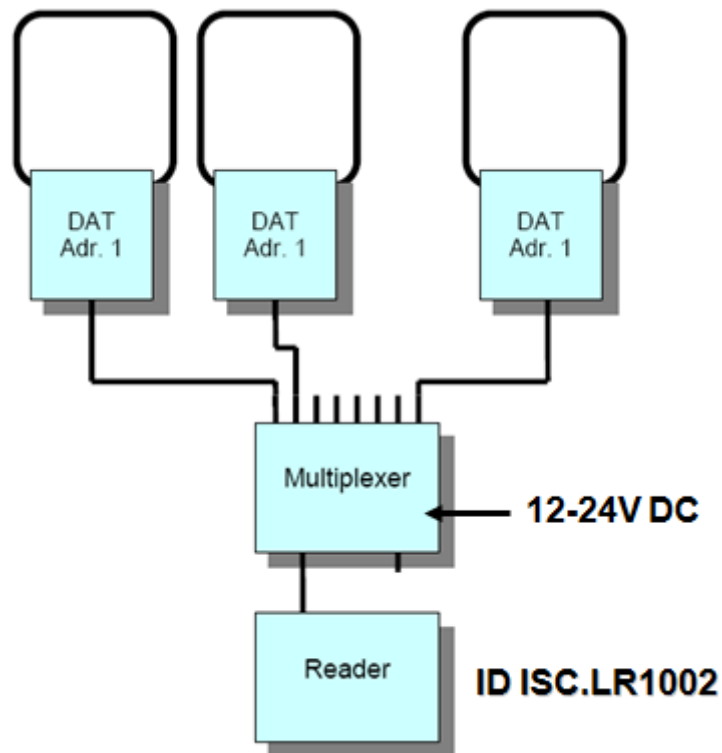

Figure 5: DC supply of a ID ISC.DAT using a ID ISC.ANT.MUX.

3.2.2 Supply voltage

The reader has to be supplied by a limited power supply according EN 62368-1 Chapter Q.1, or with a NEC Class 2/LPS certified power supply.

The external wiring for the power supply must be compliant with

- IEC 60332-2-1 and IEC 60332-2-2 for Wire Cross Section < 0.5 mm²
- IEC 60332-1-2 and IEC 60332-1-3 for Wire Cross Section > 0.5 mm²

The supply voltage of 24 V $\overline{\text{---}}$ is connected to Terminal X1.

Terminal	Abbreviation	Description
X1	VIN	Vcc – supply voltage + 24 V $\overline{\text{---}}$ $\overline{\text{---}}$ Direct current symbol
X1	GND	Ground – supply voltage

Table 3: Pin-outs for supply voltage on X1

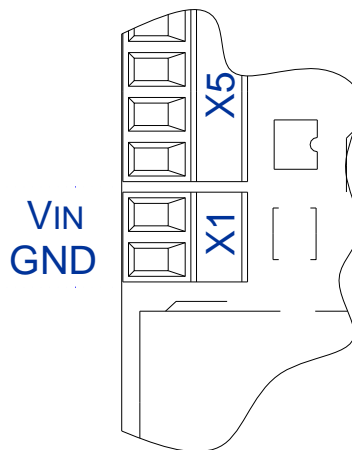

Figure 6: Position of the connector X1 for the power supply

Note:

- Reversing the supply voltage polarity may destroy the device.
- For reducing the noise the power supply line can be fitted with one EMC ring cores $\varnothing 28$ mm x 20 mm. The power supply line must be wound around the ring core for at least 5 turns. The distance between the Reader termination and the ring core should be maximum 10 cm.

3.2.3 OptocouplerInputs (X5 / IN1)

The optocoupler input is available on Terminal X5.

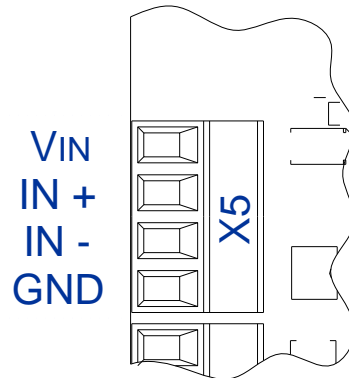

Figure 7: Optocoupler pin-outs on terminal X5

The optocoupler on terminal strips X5 is galvanically isolated from the Reader electronics and must therefore be powered externally. The external VCC voltage and GND (Ground) may however be provided by the connector VIN (24VDC) and GND from the reader. See:

Output **24V** --- (X5 / VIN, GND)

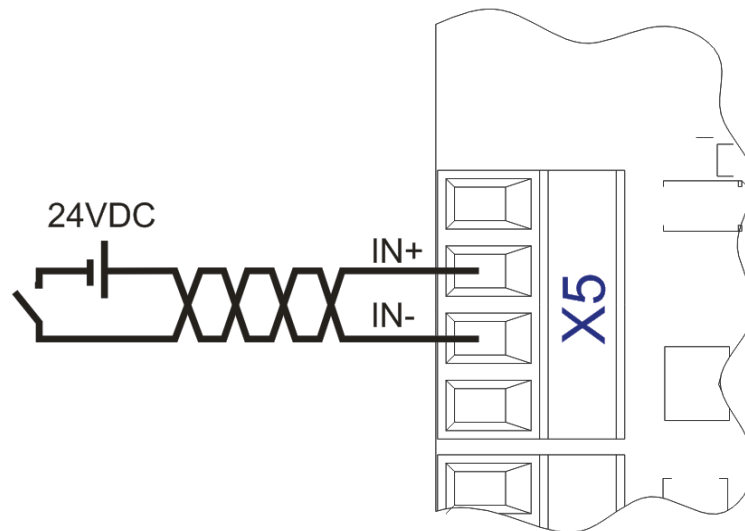

Figure 8: External power supply for the optocouplers

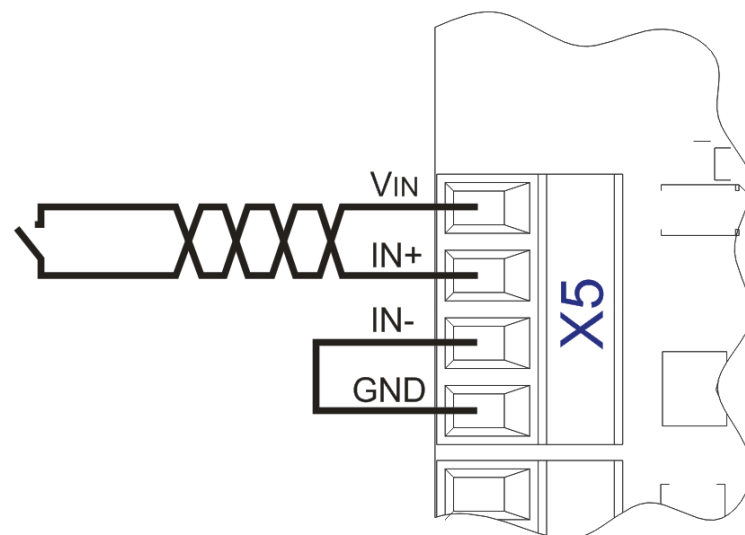

Figure 9: Possible internal power supply for the optocouplers

The input LED for the optocoupler is internally connected to a series resistor of 3,74k Ω and is limited to an input current of max. 6mA.

Note:

- **The input is configured for a maximum input voltage of 24 V --- and an input current of maximum 6mA.**
- **Reversing the polarity or overloading the input can destroy the device.**
- **Using internal and external voltage at the same time can destroy the reader.**

3.2.4 Relay (X6 / REL1)

The relay output has a changeover contact. These outputs, which are located on terminals X6, is galvanically isolated from the Reader electronics and must therefore be externally supplied. The external voltage may however be provided by the reader from connector X5 VIN and GND. See:

Output 24V --- (X5 / VIN, GND)

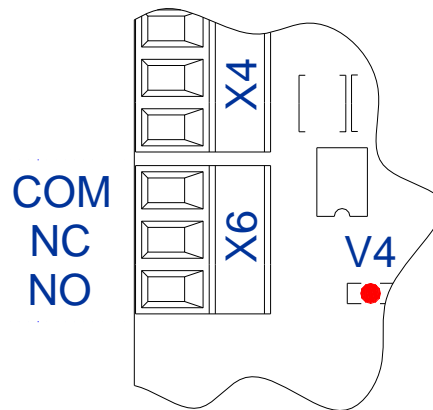

Figure 10: Relay Outputs on terminal X6

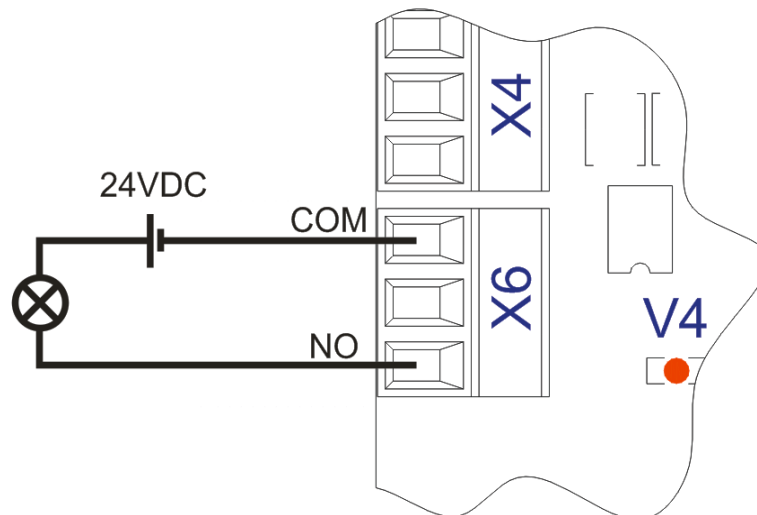

Figure 11: External wiring of the relay output's with external voltage

Notes:

- The relay output is configured for max. 24 V --- / 1 A.
- The relay output is intended for switching resistive loads only. If an inductive load is connected, the relay contacts must be protected by means of an external protection circuit.
- Using internal and external voltage at the same time can destroy the reader.

3.2.5 Output 24V $\overline{\text{---}}$ (X5 / V_{IN} , GND)

The output **V_{IN}/GND** can be used to power the optional external circuitry of the digital inputs or relay. The maximum current consumption must not exceed 1A.

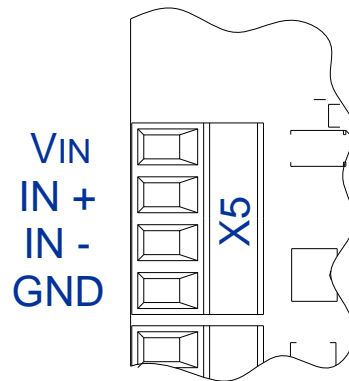

Figure 12: Optional 24V $\overline{\text{---}}$ external voltage supply

Note:

- *For the dimensioning of the power supply the power consumption for the external output circuitry must be additional considered to the typical reader power consumption.*
- The internal 24V $\overline{\text{---}}$ voltage on X5 is not protected by a fuse.

3.3 Interfaces

3.3.1 RS232-Interface X4

The RS232 interface is connected on X4. The transmission parameters can be configured by means of software protocol.

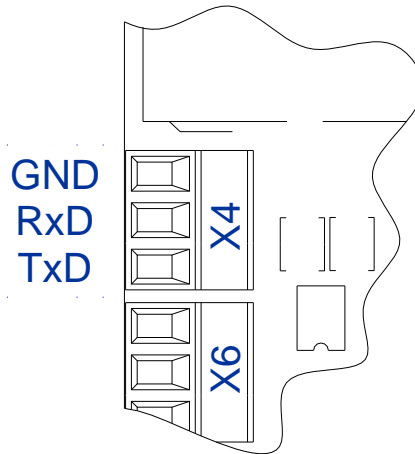

Figure 13: RS232 interface pin-outs on X4

Kurzzeichen	Description
TxD	RS232 – (Transmit)
RxD	RS232 – (Receive)
GND	RS232 – (Ground)

Table 4: Pin assignment of the RS232-Interface

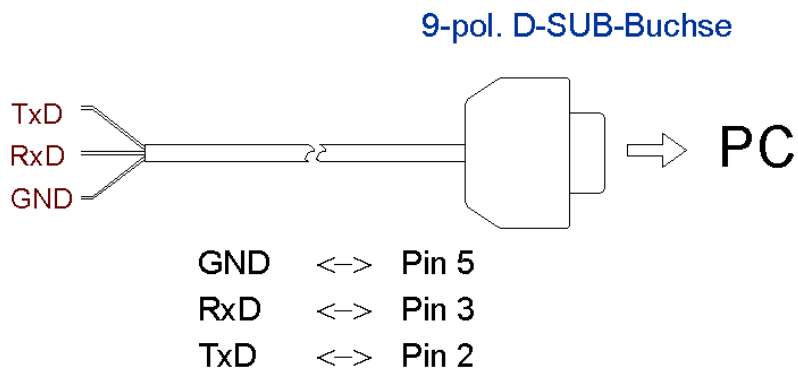

Figure 14: Wiring example for connecting the RS232 interface

3.3.2 USB – Interface X11 (Host Communication)

The USB socket on the board is terminal X11. The data rate is reduced to 12 Mbit (USB full speed). A standard USB-cable can be used.

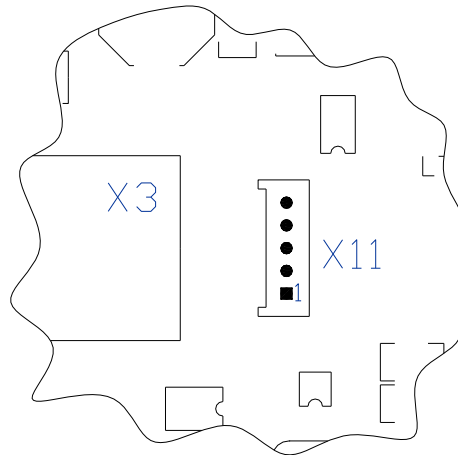

Figure 15: USB-Interface for host communication

The Figure 16 and table shows the connection of connector X11 (5pol.) type “JST PH” RM 2 mm (vertical).

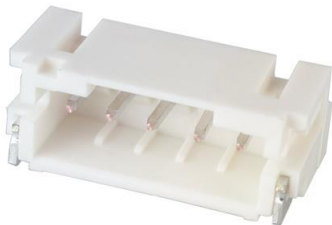

Figure 16: Connector „JST PH“

X2 Pin-No.		
1	Shielding	USB cable - shielding
2	GND	
3	USB-D PLUS	
4	USB-D MINUS	
5	VCC	+ 5 V DC \pm 5 %

Optional the following USB cable can be ordered:

3541.000.00	ID CAB.USB-B Cable for Interface USB/JST PH
-------------	---

Note:

The length of the USB-cable can be a max. of 5m (200 inch). It is not allowed to use longer cables.

3.3.3 Ethernet-Interface on X3 (10/100 Base-T)

The Reader has an integrated 10 / 100 Base-T network port for an RJ-45. Connection is made on X3 and has an automatic "Crossover Detection" according to the 1000 Base-T Standard.

X3

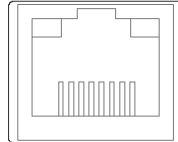

Figure 17: LAN interface for host communication

The prerequisite for using TCP/IP protocol is that each device has a unique address on the network. All Readers have a factory set IP address.

Network	Address
IP-Adresse	192.168.10.10
Subnet-Mask	255.255.255.0
Port	10001
DHCP	OFF

Table 5 Standard factory configuration of the Ethernet connection

Note:

- **The Reader TCP/IP interface has a DHCP option.**
- **With structured cabling STP CAT 5 cables must be used. This ensures a reliable operation at 10 Mbps or 100 Mbps.**

4 Operating and Display Elements



4.1 LEDs

Abbreviation	Description
LED V1 (green)	"RUN-LED 1" <ul style="list-style-type: none">- Indicates proper running of the internal Reader software (DSP)- Comes on during Reader initialization after power-on or after a reset.
LED V2 (blue)	Diagnostic 1: RF communication / EEPROM status <ul style="list-style-type: none">- Short flashing indicates errorless communication with a transponder on the RF interface- Flashes alternately with V1 after a reset following a software update- Flashes alternately with V1 in case of a data error when reading the parameters after a reset
LED V3 (yellow)	Diagnostic 2: Host communication <ul style="list-style-type: none">- Short flashing indicates sending of a protocol to the host on the RS232/USB and LAN-Interface
LED V4 (red)	Diagnostic 4: RF warning <ul style="list-style-type: none">- Comes on when there is an error in the RF section of the Reader. The error type can be read out via software over the RS232/USB and LAN-Interface

Table 6: LED configuration

5 Radio Approvals

5.1 Declaration of Conformity (CE), (UKCA), (USA), (Canada)

	<p>Declaration of Conformity (CE)</p> <p>Hereby, FEIG ELECTRONIC GmbH declares that the radio equipment type ID ISC.LRM1002-Eis in compliance with Directive 2014/53/EU.</p> <p>The full text of the EU declaration of conformity is available at the following internet address: https://www.feig.de/en/service/eu-declarations-of-conformity/</p>
	<p>UKCA Declaration of Conformity</p> <p>Hereby FEIG ELECTRONIC GmbH declares that the radio equipment type ID ISC.LRM1002-Eis in compliance with Directive No. 1206 Radio Equipment Regulations 2017.</p> <p>The full text of the UKCA declaration of conformity is available at the following internet address: https://www.feig.de/en/service/ukca-declarations-of-conformity/</p>

5.2 USA (FCC) and Canada (IC)

Product name:	ID ISC.LRM1002-E
Reader name:	ID ISC.LRM1002-E
FCC ID: IC:	PJMLRM1002 6633A-LRM1002
Notice for USA and Canada	<p>This device complies with Part 15 of the FCC Rules and with RSS-210 of Industry Canada.</p> <p>Operation is subject to the following two conditions.</p> <p>(1) this device may not cause harmful interference, and</p> <p>(2) this device must accept any interference received, including interference that may cause undesired operation.</p> <p>Unauthorized modifications may void the authority granted under Federal communications Commission Rules permitting the operation of this device.</p> <p>This equipment has been tested and found to comply with the limits for a Class A digital device, pursuant to Part 15 of the FCC Rules. These limits are designed to provide reasonable protection against harmful interference when the equipment is operated in a commercial environment. This equipment generates, uses, and can radiate radio frequency energy and, if not installed and used in accordance with the instruction manual, may cause harmful interference to radio communications. Operation of this equipment in a residential area is likely to cause harmful interference in which case the user will be required to correct the interference at his own expense.</p> <p>Le présent appareil est conforme aux CNR d'Industrie Canada applicables aux appareils radio exempts de licence. L'exploitation est autorisée aux deux conditions suivantes :</p> <p>(1) l'appareil ne doit pas produire de brouillage, et</p> <p>(2) l'utilisateur de l'appareil doit accepter tout brouillage radioélectrique subi, même si le brouillage est susceptible d'en compromettre le fonctionnement.</p>

Warning: Changes or modification made to this equipment not expressly approved by FEIG ELECTRONIC GmbH may void the FCC authorization to operate this equipment.

Installation with FCC / IC Approval:

FCC-/IC-NOTICE: To comply with FCC Part 15 Rules in the United States / with IC Radio Standards in Canada, the system must be professionally installed to ensure compliance with the Part 15 certification / IC certification. It is the responsibility of the operator and professional installer to ensure that only certified systems are deployed in the United States / Canada.

5.2.1 Label Information Reader Modul ID ISC.LRM1002-E

The following information has to be mount outside on the housing of the reader.

<p>Contains FCC ID: PJMLRM1002 Contains IC: 6633A-LRM1002</p>

5.2.2 USA (FCC) and Canada (IC) approved antennas

This radio transmitter (identify the device by certification number, or model number if Category II) has been approved by Industry Canada to operate with the antenna types listed below with maximum permission gain and required antenna impedance for each antenna type indicated. Antenna types, not included in this list, having a gain greater than the maximum gain indicated for that type, are strictly prohibited for use with this device

Le présent émetteur radio (identifier le dispositif par son numéro de certification ou son numéro de modèle s'il fait partie du matériel de catégorie I) a été approuvé par Industrie Canada pour fonctionner avec les types d'antenne énoncé ci-dessus et ayant un gain admissible maximal et l'impédance requise pour chaque type d'antenne. Les types d'antenne non inclus dans cette liste, ou dont le gain est supérieur au gain maximal indiqué, sont strictement interdits pour l'exploitation de l'émetteur

Following antennas are approved by FCC according FCC Part 15 and IC Canada according RS210

- ID ISC.ANT310/310-A (magnetic antenna)
- ID ISC.ANTS370/270-A (magnetic antenna)
- ID ISC.ANT1300/680-A (magnetic antenna)

6 Technical Data

Mechanical Data					
Weight	0,35 kg				
Dimensions (W x H x D)	160 mm x 120 mm x 35 mm (6.29 inch x 4.72 inch x 1,38 inch)				
Electrical Data					
Power supply	24 V \pm 15 %				
Power consumption	Max.16 VA				
Antenna	External (50 Ω , SWR \leq 1.3)				
Antenna Connection					
DC Supply at Antenna Connector	6,5 V (max. 20mA)				
Diagnostic Options	internal impedance monitoring internal temperature monitoring				
Outputs – 1 Relay (1 x NO)	24 V / 1 A				
Inputs – 1 Optocoupler	24 V / 6 mA				
Operating frequency	13,56 MHz				
RF transmitting power	1 W – 5 W (adjustable)				
Supported Transponder	<ul style="list-style-type: none"> ISO15693, ISO18000-3-A (EM HF ISO Chips, Fujitsu HF ISO Chips, KSWSensor Chips, Infineon my-d, NXP I-Code, STM ISO Chips, TI Tag-it) ISO18000-3M3 (Upgrade Code required) 				
Protocol Modes	ISO Host Mode BRM (Data Filtering and Data Buffering) Scan Mode Notification Mode				
Indicator	4 x LED				
Interface	RS232 USB Ethernet (TCP/IP)				
Environmental Conditions					
Temperature range	<table border="0"> <tr> <td style="text-align: right;">Operation</td> <td>-13 °F – +131 °F</td> </tr> <tr> <td style="text-align: right;">Storage</td> <td>-13 °F – +185 °F</td> </tr> </table>	Operation	-13 °F – +131 °F	Storage	-13 °F – +185 °F
Operation	-13 °F – +131 °F				
Storage	-13 °F – +185 °F				
Humidity	5% - 80% (non-condensing)				
Vibration	EN 60068-2-6 10 Hz to 150 Hz : 0,075 mm / 1 g				
Shock	EN 60068-2-27 Acceleration: 30 g				

Applicable Standards

RF Approval	Europe	EN 300 330
	UK	EN 300 330
	USA	FCC 47 CFR Part 15
	Canada	RSS-210
EMC		EN 301 489
Safety	Low Voltage Directive	EN 62368-1
	Human Exposure	EN 50364