

INSTALLATION

ID PAD74-U

PAD Reader with USB Interface



NOTE

© Copyright by

FEIG ELECTRONIC GmbH
Industriestraße 1a
D-35781 Weilburg (Germany)
Tel.: +49 6471 3109-0

[https://www.feig.de/en/
identification-support@feig.de](https://www.feig.de/en/identification-support@feig.de)

With the edition of this document, all previous editions become void. Indications made in this manual may be changed without previous notice.

Copying of this document and giving it to others and the use or communication of the contents thereof are forbidden without express authority. Offenders are liable to the payment of damages. All rights are reserved in the event of the grant of a patent or the registration of a utility model or design.

Composition of the information in this document has been done to the best of our knowledge. FEIG ELECTRONIC GmbH does not guarantee the correctness and completeness of the details given in this manual and may not be held liable for damages ensuing from incorrect or incomplete information. Since, despite all our efforts, errors may not be completely avoided, we are always grateful for your useful tips.

The instructions given in this manual are based on advantageous boundary conditions. FEIG ELECTRONIC GmbH does not give any guarantee promise for perfect function in cross environments and does not give any guarantee for the functionality of the complete system which incorporates the subject of this document.

FEIG ELECTRONIC GmbH calls explicit attention that devices which are subject of this document are not designed with components and testing methods for a level of reliability suitable for use in or in connection with surgical implants or as critical components in any life support systems whose failure to perform can reasonably be expected to cause significant injury to human health. To avoid damage, injury or death the user or application designer must take reasonably prudent steps to protect against system failures.

FEIG ELECTRONIC GmbH assumes no responsibility for the use of any information contained in this document and makes no representation that they are free of patent infringement. FEIG ELECTRONIC GmbH does not convey any license under its patent rights nor the rights of others.

All brand names, trademarks or logos are the property of their respective owners.

Safety Instructions

- ▶ The device may only be used for the intended purpose designed by for the manufacturer.
- ▶ The operation manual should be conveniently kept available at all times for each user.
- ▶ Unauthorized changes and the use of spare parts and additional devices which have not been sold or recommended by the manufacturer may cause fire, electric shocks or injuries. Such unauthorized measures shall exclude any liability by the manufacturer.
- ▶ The liability-prescriptions of the manufacturer in the issue valid at the time of purchase are valid for the device. The manufacturer shall not be held legally responsible for inaccuracies, errors, or omissions in the manual or automatically set parameters for a device or for an incorrect application of a device.
- ▶ Repairs may only be executed by the manufacturer.
- ▶ Installation, operation, and maintenance procedures should only be carried out by qualified personnel.
- ▶ Use of the device and its installation must be in accordance with national legal requirements and local electrical codes.
- ▶ When working on devices the valid safety regulations must be observed.
- ▶ Before touching the device, the power supply must always be interrupted. Make sure that the device is without voltage by measuring. The fading of an operation control (LED) is no indicator for an interrupted power supply or the device being out of voltage!
- ▶ Special advice for wearers of cardiac pacemakers:
Although this device doesn't exceed the valid limits for electromagnetic fields you should keep a minimum distance of 25 cm between the device and your cardiac pacemaker and not stay in the immediate proximity of the device's antenna for any length of time.

Content

1	ID PAD74-U PAD Reader with USB-Interface	5
1.1	Scope of delivery	5
1.2	Available Software-Tools, USB drivers and Firmware	6
1.3	Difference between ID PAD74-U and ID CPR74-CUSB	6
2	Dimension	7
3	Installation	9
3.1	Table top mounting	9
3.2	Under table mounting.....	9
4	Commissioning	12
4.1	DC Power supply	12
4.2	LED Indication	12
5	Radio Approvals	13
5.1	Declaration of Conformity (CE), (UKCA)	13
6	Technical Data	14
7	Cleaning / Care	15

1 ID PAD74-U PAD Reader with USB-Interface

- The ID PAD74-U is an RFID PAD reader for contactless data exchange with passive transponders and combines a reader and an antenna in one housing.
- The compact format allows the PAD74-U to be positioning "on" and "under" any nonmetallic mounting or table top.
- It is suitable for many desktop applications in offices, industry or libraries (output and return). The high processing speed and easy configuration allow ideal adaptation to the customer application.
- There are three status LEDs (color green, blue, red) on the front side, which indicates the status of the reader with antenna ([see 4.2 LED Indication](#)).

Features	
Supported Standards	<ul style="list-style-type: none"> • ISO 15693 • ISO 18000-3 Mode1
Operating Frequency	<ul style="list-style-type: none"> • $f = 13,56$ MHz
Max. RF Transmitting Power	<ul style="list-style-type: none"> • $P = 400$ mW
Antenna Connection	<ul style="list-style-type: none"> • fixed cable • USB Interface
Protection Class	<ul style="list-style-type: none"> • IP30
Status LED	<ul style="list-style-type: none"> • LED (green, blue, red)

Table 1: Features

1.1 Scope of delivery

- ID PAD74-U PAD Reader with USB-Interface
- Document "Quickstart"

1.2 Available Software-Tools, USB drivers and Firmware

The service software and the corresponding USB driver (HF/UHF reader or FEIG ID driver) for personal computers with Microsoft® Windows® operating systems, are available on the Feig homepage under "Service -> Driver".

Further documents and software tools can be found under the link:

<https://www.feig.de/en/login/>

Login: CPR74

Password : FE900

① **NOTE:**

- The Reader ID PAD74-U reports itself in ISOStart+ 2023 (version 11.08.xx or higher) as "ID CPR74".
- A firmware update tool and an xml firmware file are available for firmware updates.

1.3 Difference between ID PAD74-U and ID CPR74-CUSB

The reader module installed in the ID PAD74-U does not support all commands and functions that are available in the reader module ID CPR74-CUSB.

[\(see Manual H60410-Xe-ID-B\)](#)

Since ISO 15693 and ISO 14443-A/B transponders are mainly used in the intended applications, the following transponder drivers have been switched off in the reader configuration and cannot be activated.

Unavailable functions and transponder drivers:

- ISO 18000-3M3

① **NOTE:**

- The ID PAD74-U rejects the activation of an invalid transponder driver" with the error message "Parameter Range Error".
- The commands of the internal reader ID CPR74-CUSB belonging to the disabled transponder driver are not available.
- In the factory default state, the provided antenna (ANT2) inside ID PAD74-U is activated. The internal antenna installed on the reader module ID CPR74-CUSB can additionally be activated via the reader configuration.

2 Dimension



Figure 1: Front view

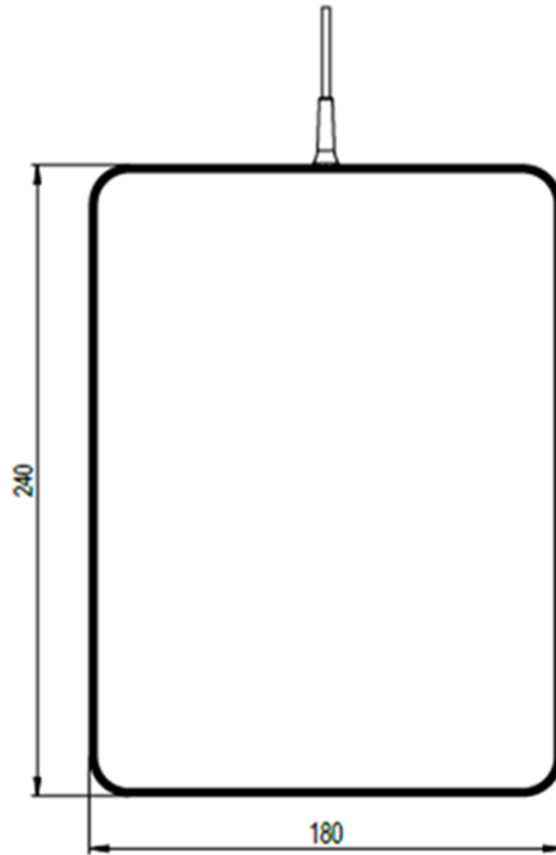

Figure 2: Top view with housing dimension

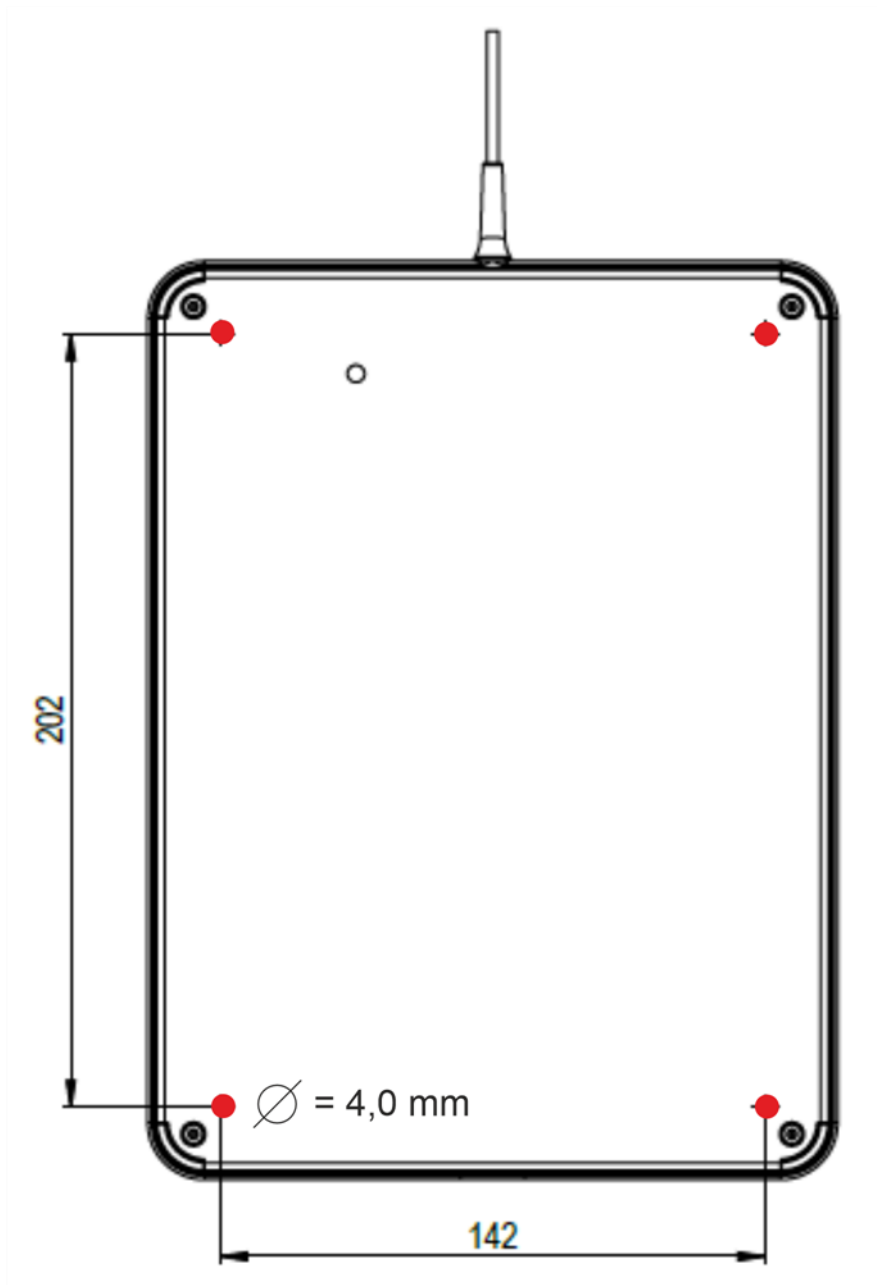

Figure 3: Drilling pattern under table mounting

3 Installation

- The PAD74-U is designed for operation on a non metallic, flat surface (e.g. table) or for under table mounting (non metallic) indoors.
- Device connection via USB cable (2.3 m)
- The cable length must not be changed.

3.1 Table top mounting

- Positioning the device on the table top.
- The rubber feet on the bottom of the case prevent it from moving.

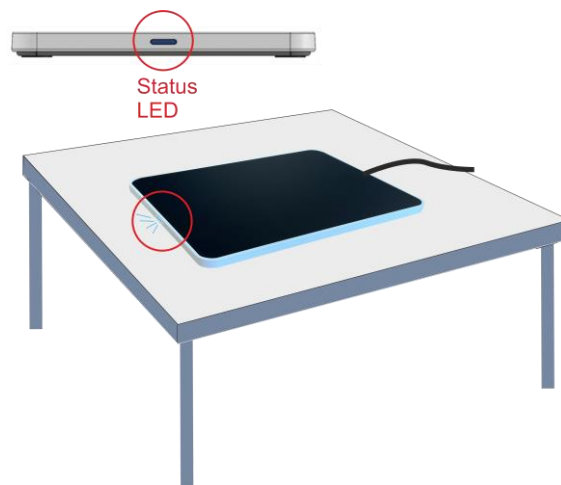

Figure 4: Table top mounting

3.2 Under table mounting

Please follow the instructions in the Table 2: "Instructions for under table mounting".

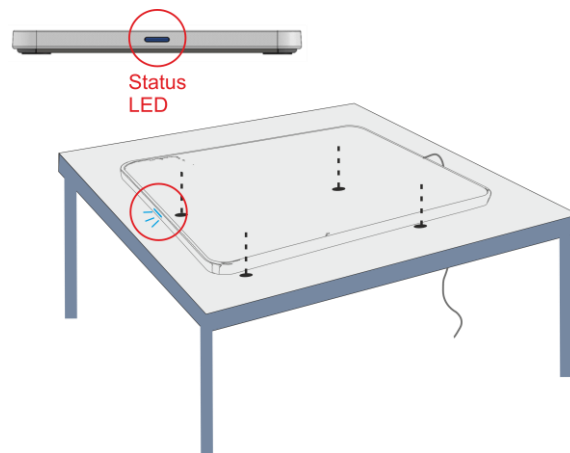

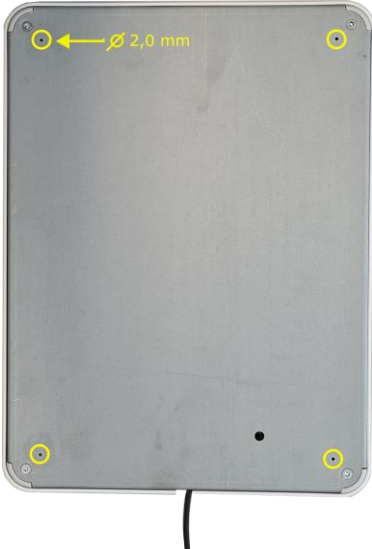



Figure 5: Under table mounting

<ul style="list-style-type: none"> Remove rubber feet Use drilling pattern, (see Fig. 3) The predrilled holes (2.0 mm) are located under the rubber feet. 	 <p>Figure 6: Remove rubber feet</p>	 <p>Figure 7: Predrilled holes (2.0 mm)</p>
<ul style="list-style-type: none"> Drill out factory holes from 2.0 mm to 4.0 mm 	 <p>Figure 8: Drill out factory holes to 4.0 mm</p>	
<ul style="list-style-type: none"> The under-table mounting is carried out via the rear of the housing using pan head screws (max. M3 x 3.5 mm). The four pan head screws must penetrate the top of the antenna. 	 <p>Figure 9: Pan head screws (max. M3 x 3.5 mm)</p>	

- The antenna is aligned with the top (front foil side) facing up and mounted.



Figure 10: Under table mounting

① **NOTE:**

- Before mounting, the rubber feet must be removed.
- Use drilling pattern
- Drilling holes at locations other than provided in drilling pattern, will destroy the electronics.
- Make sure that the surface of the tabletop is not damaged.
The length of the screws must be dimensioned according to the table top thickness.
- The table top must not be made of metal or magnetically materials.
- If the mounting/table top is too thick (wood, plastic), the reading range is reduced (ideally < 25 mm).

Table 2: Under table mounting

4 Commissioning

- Device connection via USB cable (2.3 m)
The cable length must not be changed.
- The device has no ON/OFF switch. All functions (status displays, transponder detection) are displayed via the status LEDs (green, blue, red) and are available after the startup process
([see 4.2 LED Indication](#))
- The standard reader configuration can be adapted to the application using the ISOStart service software from version 11.07.xx or higher
- The service software can be found on the download area of FEIG ELECTRONIC GmbH at <https://www.feig.de/en/>

4.1 DC Power supply

- $U = 5 \text{ VDC}$
- $I_{\text{max}} = 500 \text{ mA}$
- Via USB 2.0

4.2 LED Indication







	LED-Signal	Description
	Green LED / RUN LED flashes	Reader is in Host-Mode
	Green LED / RUN LED is on	Reader is in Scan-Mode
	Blue LED is on (1 s)	Transponder detected
	Green and red LED flashes alternately	ERROR message

Table 3: LED Indication

5 Radio Approvals

5.1 Declaration of Conformity (CE), (UKCA)

	<p>CE Declaration of Conformity</p> <p>Hereby FEIG ELECTRONIC GmbH declares that the radio equipment type ID PAD240-U is in compliance with directive 2014/53/EU.</p> <p>The full text of the EU declaration of conformity is available at the following internet address: https://www.feig.de/en/service/eu-declarations-of-conformity/</p>
	<p>UKCA Declaration of Conformity</p> <p>Hereby FEIG ELECTRONIC GmbH declares that the radio equipment type ID PAD240-U is in compliance with directive No. 1206 Radio Equipment Regulations 2017.</p> <p>The full text of the UKCA declaration of conformity is available at the following internet address: https://www.feig.de/en/service/ukca-declarations-of-conformity/</p>

6 Technical Data

Mechanical Data	
Wight:	approx. 0,5 kg
Dimension: (L x W x H)	(240 x 180 x 13) mm ³ (9,45 x 7,08 x 0,51) in ³
Front cover:	Insensitive surface
Housing:	ABS
Protection class:	IP30
Color: PAD Upper side	RAL 9003 (white) black
Electrical Data	
Operating frequency:	13,56 MHz
Max. RF transmitting power:	P = 400 mW
Power supply:	5 V DC via USB
Max. Power consumption:	P = 2,5 W
Interface:	USB 2.0
LED Indicator:	3 x LEDs (green, blue, red)
Supported Transponder:	<ul style="list-style-type: none"> • ISO 15693 • ISO 14443-A/B • NFC Tag Type 1-4 • ISO 18000-3 MODE 1 e. g. EM HF ISO Chips, Fujitsu HF ISO Chips, Infineon my-d, KSW Sensor Chips, NXP ICODE SLI family, STM ISO Chips, TI Tag-it, NXP MIFARE family, NFC Devices in Card Emulation Mode (Tag Type 1...5)
Reader Mode :	ISO Host Mode Scan Mode
Temperature range: Operation Storage	-25 °C bis +55 °C (-13 °F up to 131 °F) -25 °C bis +70 °C (-13 °F up to 158 °F)
Relative air humidity:	5 % bis 95 % (no condensing)
Standard conformity	
Radio license: Europe UK USA Canada	EN 300 330 EN 300 330 FCC 47 CFR Part 15 IC RSS-GEN, RSS-210
EMC:	EN 301 489
Safety & Health:	EN 62368-1, EN 50364

Table 4: Technical Data

7 Cleaning / Care

Clean surfaces with clean, soft microfiber cloth and a solution of water with a little detergent.

① **NOTE:**

- Using the wrong cleaning agents or cleaning cloths can damage the surface of the front foil.
- Do not use harsh, solvent-based or corrosive cleaning agents.

Document: Installation ID PAD74-U
Id-No. Document Version: M30521-1e-ID-B
Date: 01.09.2023

© Copyright

All brand names, product names or trademarks cited are the property of their respective owners.

FEIG ELECTRONIC GmbH
Industriestraße 1a
35781 Weilburg, Germany
Phone: +49 6471 3109-0

Homepage: <https://www.feig.de/en/>
Email: identification-support@feig.de