

---

**Electromagnetic Emission**  
**FCC MEASUREMENT REPORT**  
**CERTIFICATION OF COMPLIANCE**  
**FCC Part 15 Certification Measurement**

---

**PRODUCT** : LCD MONITOR  
**MODEL/Serial No.** : L24C0F080 / NONE  
**FCC ID** : PJIL24C0F080  
**BRAND NAME** : HYUNDAI  
**APPLICANT** : HYUNDAI IT CORP.  
San 136-1, Ami-ri, Bubal-eub, Icheon-si, Gyeonggi-do,  
467-701, Korea  
Attn. : Kim, Kyoung-Ok / Assistant Manager  
**MANUFACTURER** : HYUNDAI IT CORP.  
San 136-1, Ami-ri, Bubal-eub, Icheon-si, Gyeonggi-do,  
467-701, Korea  
**FCC CLASSIFICATION** : Class B Personal computers and peripherals  
**RULE PART(S)** : FCC Part 15 Subpart B & ICES-003 Issue 4  
**FCC PROCEDURE** : ANSI C63.4-2003  
**TEST REPORT No.** : ETLE090320.03  
**DATES OF TEST** : March 24, 2009 to March 26, 2009  
**REPORT ISSUE DATE** : April 16, 2009  
**TEST LABORATORY** : ETL Inc. (FCC Designation Number : KR0022)

This LCD MONITOR, Model L24C0F080 has been tested in accordance with the measurement procedures specified in ANSI C63.4-2003 at the ETL Test Laboratory and has been shown to be complied with the electromagnetic radiated emission limits specified in FCC Rule Part15 Subpart B & ICES-003 Issue 4: I attest to the accuracy of data. All measurement herein was performed by me or was made under my supervision and is correct to the best of my knowledge and belief. I assume full responsibility for the completeness of these measurements and vouch for the qualifications of all persons taking them. The results of testing in this report apply to the product/system which was tested only. Other similar equipment will not necessarily produce the same results due to production tolerance and measurement uncertainties.



---

Yo Han, Park / Chief Engineer

**ETL Inc.**  
**#584, Sangwhal-ri, Ganam-myeon, Yaju-gun, Gyeonggi-do, 469-885, Korea**  
**Tel: 82-2-858-0786 Fax: 82-2-858-0788**

## Table of Contents

### FCC Measurement Report

1. Introduction
2. Product Information
3. Description of Tests
4. Test Condition
5. Test Results
  - 5.1 Summary of Test Results
  - 5.2 Conducted Emissions Measurement
  - 5.3 Radiated Emissions Measurement
6. Sample Calculation
7. List of test Equipment used for Measurement

Appendix A. N/A

Appendix B. Test Setup Photographs

Appendix C. External Photographs

Appendix D. Internal Photographs

Appendix E. Block Diagram

Appendix F. User Manual

## FCC MEASUREMENT REPORT

**Scope** – Measurement and determination of electromagnetic emission(EME) of radio frequency devices including intentional radiators and/or unintentional radiators for compliance with the technical rules and regulations of the U.S Federal Communications Commission(FCC)

### General Information

<b>Applicant Name</b>	: HYUNDAI IT CORP.
<b>Address</b>	: San 136-1, Ami-ri, Bubal-eub, Icheon-si, Gyeonggi-do, 467-701, Korea
<b>Attention</b>	: Kim, Kyoung-Ok / Assistant Manager

- **EUT Type :** LCD MONITOR
- **Model Number :** L24C0F080
- **S/N :** NONE
- **Frequency Range :** X-TAL → 14.31818 MHz
- **FCC Rule Part(s) :** FCC Part 15 Subpart B & ICES-003 Issue 4
- **Test Procedure :** ANSI C63.4-2003
- **FCC Classification :** Class B Personal computers and peripherals
- **Dates of Tests :** March 24, 2009 to March 26, 2009
- **Place of Tests :** ETL Inc. Testing Lab.  
  
Radiated Emission test;  
#499-1, Sagot-ri, Seosin-myeon, Hwaseong-si,  
Gyeonggi-do, 445-882, Korea  
  
Conducted Emission test;  
ETL Inc. Testing Lab.  
371-51, Gasan-dong, Geumcheon-gu, Seoul, 153-803, Korea
- **Test Report No. :** ETLE090320.03

## 1. INTRODUCTION

The measurement test for radiated and conducted emission test were conducted at the ETL Inc. The site is constructed in conformance with the requirements of the ANSI C63.4-2003 and CISPR Publication 16. The ETL has site descriptions on file with the FCC for 3 m and 10 m site configurations. Detailed description of test facility was found to be in compliance with FCC Rules according to the ANSI C63.4-2003 and registered to the Federal Communications Commission (FCC Designation Number : KR0022).

The measurement procedure described in American National Standard for Method of Measurement of Radio-Noise Emission from Low-Voltage Electrical and Electronic Equipment in the Range of 9 kHz to 40 GHz (ANSI C63.4-2003) was used in determining radiated and conducted emissions from the HYUNDAI IT CORP. Model: L24C0F080

## 2. PRODUCT INFORMATION

### 2.1 Equipment Description

The Equipment Under Test (EUT) is the HYUNDAI IT CORP. (model: L24C0F080)

### 2.2 General Specification

LCD	24" viewable, Diagonal, Pixel pitch 0.270mm, A-si TFT
Display area	518.4(H) X 324(V), 24" Diagonal
Number of color	16.7 million colors (true 8-bit color)
Input signals	R.G.B Analog(15pin D-sub)/ DVI-D / Component / HDMI
Frequency rate	Horizontal: 30.0 kHz to 80.0 kHz, Vertical: 56 Hz to 76 Hz
Maximum resolution	1 920 X 1 200 @ 60 Hz
Recommended resolution	1 920 X 1 200 @ 60 Hz
Input voltage	100 V – 240 V AC, 2.0 A
Power consumption	85 W (Typ.)
Power management	VESA DPMS
Plug & Play	VESA DDC 1/2B
OSD menu	BRIGHTNESS, CONTRAST, H/W POSITION, CLOCK, PHASE, AUTO ADJUST, AUTO COLOR, SOUND, OSD CONFIGURATION, INPUT SOURCE, DISPLAYCONTROL, GENERAL RECALL, LANGUAGE
Audio system	2 CH x 3 Watts / Ear Phone Jack
Operating Temperature	5 °C ~ 40 °C
Weight	9.9 kg unpacked, 7.9 kg packed
Dimensions	579.5 mm (W) x 455.0 mm (H) x 240.0 mm (D)

## 3. DESCRIPTION OF TESTS

### 3.1 Conducted Emission Measurement

Conducted emissions measurements were made in accordance with section 11, "Measurement of Information Technology Equipment" of ANSI C63.4-2003. The measurements were performed over the frequency range of 0.15 MHz to 30 MHz using a 50  $\Omega$  / 50  $\mu$ H LISN as the input transducer to a Spectrum Analyzer or a Test Receiver. The measurements were made with the detector set for "Peak" amplitude within a bandwidth of 9 kHz or for "quasi-peak" within a bandwidth of 9 kHz.

The line-conducted emission test is conducted inside a shielded anechoic chamber room with 1 m x 1.5 m x 0.8 m wooden table which is placed 0.4 m away from the vertical wall and 1.5 m away from the side wall of the chamber room. Two LISN are bonded to the shielded room. The EUT is powered from the LISN and the support equipment is powered from the other LISN. Power to the LISNs are filtered by a noise cut power line filters. All electrical cables are shielded by braided tinned steel tubing with inner  $\phi$  1.2 cm. If the EUT is a DC-powered device, power will be derived from the source power supply it normally will be powered from and these supply lines will be connected to the LISN. Non-inductive bundling to a 1 m length shortened all interconnecting cables more than 1 m. Sufficient time for the EUT, support equipment, and test equipment was allowed in order for them to warm up to their normal operating condition. The RF output of the LISN was connected to the EMI Test Receiver to determine the frequency producing the maximum emission from the EUT. The frequency producing the maximum level was reexamined using to set Quasi-Peak mode by manual, after scanned by automatic Peak mode from 0.15 MHz to 30 MHz. The bandwidth of the spectrum analyzer was set to 9 kHz. The EUT, support equipment, and interconnecting cables were arranged and manipulated to maximize each emission.

Photographs of the worst-case emission can be seen in photographs of conducted emission test setup in Appendix B.

## 3.2 Radiated Emission Measurement

Radiated emission measurements were made in accordance with section 11, "Measurement of Information Technology Equipment" of ANSI C63.4-2003. The measurements were performed over the frequency range of 30 MHz to 1 GHz using antenna as the input transducer to a spectrum analyzer or a field intensity meter. The measurements were made with the detector set for "Quasi-peak" within a bandwidth of 120 kHz.

Preliminary measurements were made at 3 m using broadband antennas, and spectrum analyzer to determine the frequency producing the maximum emission in shielded room. Appropriate precaution was taken to ensure that all emission from the EUT were maximized and investigated. The system configuration, mode of operation, turntable azimuth and height with respect to the antenna were noted for each frequency found. The spectrum was scanned from 30 MHz to 1000 MHz using Log-Bicon antenna. Above 1 GHz, linearly polarized double ridge horn antennas were used. Final measurements were made open site at 10 m. The test equipment was placed on a wooden turn-table. Sufficient time for the EUT, support equipment, and test equipment was allowed in order for them to warm up to their normal operating condition. Each frequency found during pre-scan measurements was re-examined by manual. The detector function was set to CISPR Quasi-peak mode and the bandwidth of the receiver was set to 120 kHz or 1 MHz depending on the frequency of type of signal. The EUT, support equipment and interconnecting cables were re-configured to the set-up producing the maximum emission for the frequency and were placed on top of a 0.8 m high nonmetallic 1m x 1.5 m table. The EUT, support equipment, and interconnecting cables were re-arranged and manipulated to maximize each emission. The turntable containing the system was rotated; the antenna height was varied 1 m to 4 m and stopped at the azimuth or height producing the maximum emission. Each emission was maximized by: varying the mode of operation to the EUT and/or support equipment and changing the polarity of the antenna, whichever determined the worst-case emission.

Photographs of the worst-case emission can be seen in Photographs of the worst-case emission test setup can be seen in Appendix B.

## 4. TEST CONDITION

### 4.1 Test Configuration

The device was configured for testing in a typical fashion (as a customer would normally use it). During the tests, the following conditions and configurations were used.

### 4.2 EUT operation

- The EUT was connected as user's guide. And during the executed test program for EMI program with "H" pattern display (1 920 x 1 200, 60 Hz) on monitor and MP3 file play.

### 4.3 Support Equipment Used

Description	Model Name	Serial No.	Manufacturer
PC	DCMF	6CW7KBX	DELL INC.
DVD Player	DVR-530C	NONE	Ellion Digital
Keyboard	SK-8115	NONE	Yet Foundate Ltd
Mouse	MOC5UO	NONE	Dongguan Primax Electronics Ltd
Ear-phone	NONE	NONE	NONE

### 4.4 Type of Cables Used

Device from	Device to	Type of I/O port	Length(m)	Type of shield
EUT	PC	RGB	1.5	Shielded
EUT	PC	DVI	1.5	Shielded
EUT	PC	HDMI	1.8	Shielded
EUT	PC	PC Audio In	1.5	Shielded
EUT	DVD Player	Component	1.8	Shielded
EUT	DVD Player	Component Audio In	1.5	Shielded
EUT	Ear-phone	Ear-phone	1.2	Shielded
EUT	Power socket	AC Input	1.0	Unshielded
PC	Keyboard	USB	1.2	Shielded
PC	Mouse	USB	1.2	Shielded
PC	Power socket	AC Input	1.0	Unshielded
DVD Player	Power socket	AC Input	1.5	Unshielded



## 4.5 The setup drawing(s)

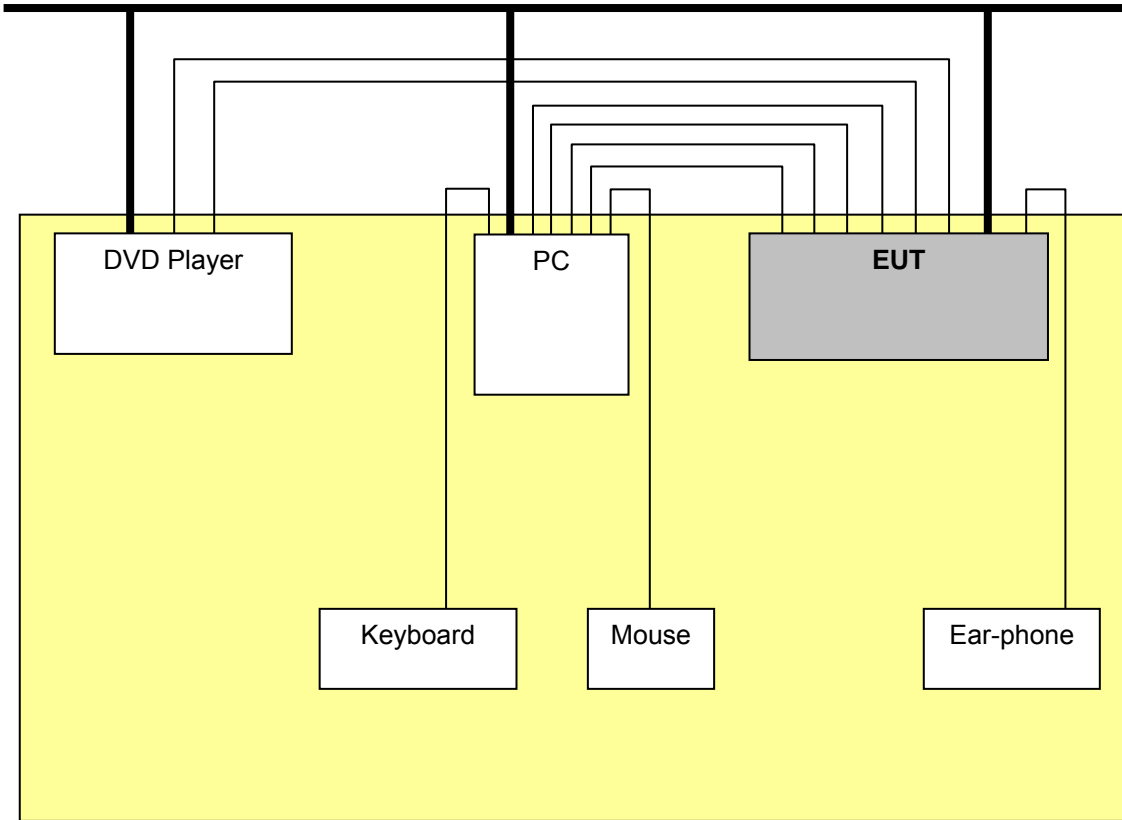

————— : Data Line  
————— : Power Line

## 5. TEST RESULTS

### 5.1 Summary of Test Results

The measurement results were obtained with the EUT tested in the conditions described in this report. Detailed measurement data and plots showing the maximum emission of the EUT are reported.

FCC Rule	Measurement Required	Result
15.107(a)	Conducted Emission Measurement	<b>Passed by 10.80 dB</b>
15.109(g)	Radiated Emission Measurement	<b>Passed by 3.30 dB</b>

The data collected shows that the HYUNDAI IT CORP. / **LCD MONITOR / L24C0F080** complied with technical requirements of above rules part 15.107(a) and 15.109(g) Class B Limits and CISPR Publication 22.

The equipment is modified anything, mechanical or circuits to improve EMI status during a measurement. EMI suppression device(s) was added and/or modified during testing.

## 5.2 Conducted Emissions Measurement

EUT	LCD MONITOR / L24C0F080 (S/N: N/A)
Limit apply to	FCC Part 15.107(a) Class B
Test Date	March 24, 2009
Operating Condition	Full "H" pattern display mode (1 920 * 1 200, Vf = 60 Hz)
Result	Passed by 10.80 dB

### Conducted Emission Test Data

The following table shows the highest levels of conducted emissions on both polarizations of hot and neutral line. Detector mode: CISPR Quasi-Peak mode (6 dB Bandwidth: 9 kHz)

Frequency [MHz]	Result [dB $\mu$ V]		Phase (*L/**N)	Limit [dB $\mu$ V]		Margin [dB]	
	Quasi-peak	Average		Quasi-peak	Average	Quasi-peak	Average
0.173	50.00	43.30	N	64.80	54.80	14.80	11.50
0.231	47.10	40.40	N	62.40	52.40	15.30	12.00
0.292	42.60	33.80	N	60.40	50.40	17.80	16.60
1.120	38.60	31.00	N	56.00	46.00	17.40	15.00
1.677	39.50	35.20	H	56.00	46.00	16.50	10.80
4.375	40.20	29.30	H	56.00	46.00	15.80	16.70
5.259	40.10	28.50	H	60.00	50.00	19.90	21.50
6.750	37.10	30.10	N	60.00	50.00	22.90	19.90

NOTES:

- \* H : HOT Line , \*\*N : Neutral Line
- Margin value = Limit – Result
- Measurement were performed at the AC Power Inlet in the frequency band of 150 kHz ~ 30 MHz according to the FCC Part 15.107(a) Class B
- If the average limit is met when using a Quasi-peak detector receiver, the EUT shall be deemed to meet both limits and measurement with the average detector receiver is unnecessary.

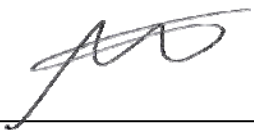

Test Engineer: **Hyung-min, Choi**

Line: HOT Line

Limit : — Quasi-Peak  
— Average

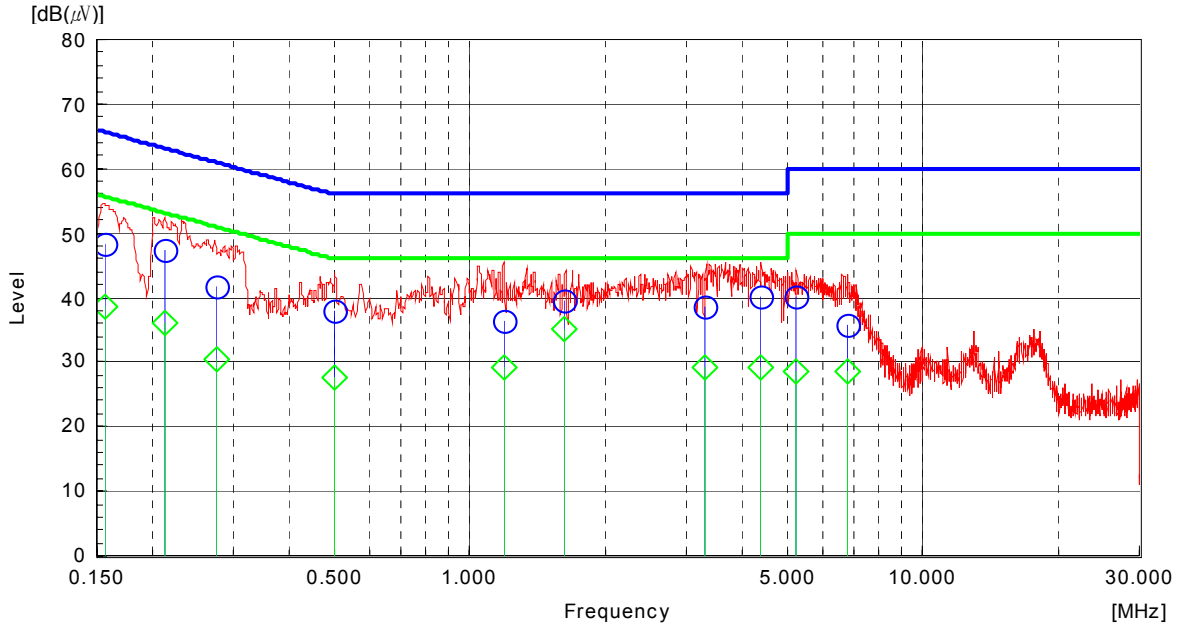

Line: Neutral Line

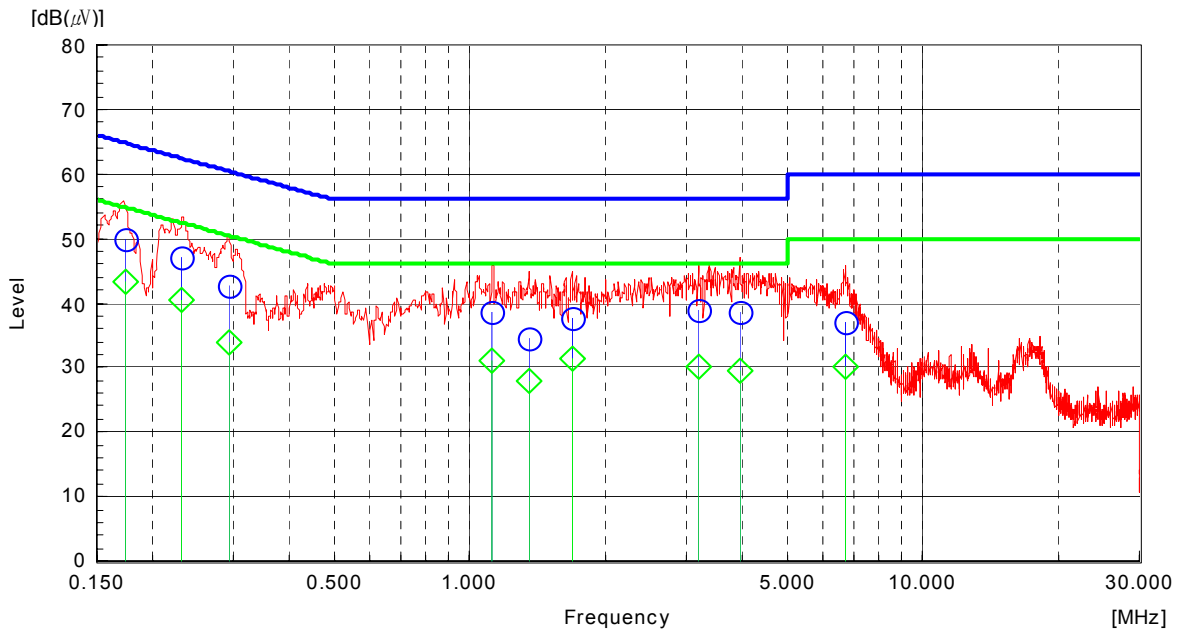

Quasi-peak ○ Average ◇

## 5.3 Radiated Emissions Measurement

EUT	LCD MONITOR / L24C0F080 (S/N: N/A)
Limit apply to	FCC Part 15.109(g) (CISPR 22 Class B)
Test Date	March 26, 2009
Operating Condition	Full "H" pattern display mode (1 920 * 1 200, Vf = 60 Hz)
Result	Passed by 3.30 dB

### Radiated Emission Test Data

The following table shows the highest levels of radiated emissions on both polarizations of horizontal and vertical. Detector mode: CISPR Quasi – Peak mode (6 dB Bandwidth: 120 kHz)

Frequency [MHz]	Reading [dB $\mu$ V]	Polarization (*H/**V)	Ant. Factor [dB/m]	Cable Loss [dB]	Result [dB $\mu$ V/m]	Limit [dB $\mu$ V/m]	Margin [dB]
34.27	12.79	V	11.23	0.88	24.90	30.00	5.10
47.29	10.59	V	12.16	1.15	23.90	30.00	6.10
67.11	13.20	V	10.13	1.37	24.70	30.00	5.30
141.12	10.78	V	12.51	2.41	25.70	30.00	4.30
184.77	11.15	V	10.42	2.83	24.40	30.00	5.60
222.12	13.19	V	9.86	3.05	26.10	30.00	3.90
248.16	17.15	H	10.86	3.19	31.20	37.00	5.80
297.94	16.02	H	12.40	3.68	32.10	37.00	4.90
310.66	15.60	V	12.71	3.79	32.10	37.00	4.90
430.77	12.40	H	15.52	4.78	32.70	37.00	4.30
542.14	10.31	H	17.74	5.65	33.70	37.00	3.30

#### NOTES:

- \* H : Horizontal polarization , \*\* V : Vertical polarization
- Result = Reading + Antenna factor + Cable loss
- Margin value = Limit - Result
- The measurement was performed for the frequency range 30 MHz – 1 000 MHz according to FCC Part 15.109(g) and CISPR 22 Class B.



Test Engineer: **Hyung-min, Choi**

## 6. SAMPLE CALCULATION

### Sample Field Strength Calculation

The field strength is calculated by adding the Antenna Factor and Cable Factor.  
The basic equation with a sample calculation is as follows:

$$FS = RA + AF + CF$$

Where FS = Field Strength

RA = Receiver Amplitude

AF = Antenna Factor

CF = Cable Attenuation Factor

$$dB(\mu V) = 20 \log_{10} (uV) : \text{Equation}$$

Example : @ 542.14 MHz

Class B Limit	=	37.00 dBuV/m (CISPR 22 Class B)
Reading	=	10.31 dBuV
Antenna Factor + Cable Loss	=	17.74 + 5.65 = 23.39 dBuV/m
Total	=	33.70 dBuV/m
Margin	=	37.00 – 33.70 = 3.30 dB
	=	3.30 dB below Limit

## 7. List of test equipments used for measurements

	Test Equipment	Model	Mfg.	Serial No.	Cal. Due Date
<input checked="" type="checkbox"/>	EMI TEST Receiver	ESVS10	R & S	835165/001	10.04.02
<input checked="" type="checkbox"/>	EMI TEST Receiver	ESPI3	R & S	100478	09.10.02
<input checked="" type="checkbox"/>	LISN	3825/2	EMCO	9208-1995	09.10.01
<input checked="" type="checkbox"/>	LISN	3816-2	EMCO	1002	09.10.01
<input checked="" type="checkbox"/>	LogBicon Antenna	VULB9160	Schwarzbeck	3082	10.01.25
<input checked="" type="checkbox"/>	Turn-Table	MFT-120S	Max-Full Antenna Corp	-	N/A
<input checked="" type="checkbox"/>	Antenna Master	MFA-440E	Max-Full Antenna Corp	-	N/A