





Test Report

Test Report No.:	KT108EF07003		
Registration No.:	99058		
Applicant:	HYUNDAI IT CORP.		
Applicant Address:	San 136-1, Ami-ri, Bubal-eup, Icheon, gyeonggi-do, 467-701, Korea		
Product:	15" TFT LCD Touch Monitor		
FCC ID:	PJIL15T0C060	Model No.	L15T0C060, G1510TR
Receipt No.:	08-0617	Date of receipt:	June 10, 2008
Date of Issue:	July 04, 2008		
Testing location:	Korea Technology Institute Co., Ltd. 51-19, Sanglim3-Ri, Docheok-Myeun, Gwangju-Shi, Gyeonggi-Do, Korea		
Test Standards:	FCC/ANSI. C63.4: 2003		
Rule Parts: FCC:	Part 15, Class B		
Equipment Class:	Computing Device Peripheral		
Test Result:	The above-mentioned product has been tested with compliance.		
Tested by: T. W. Lee / Engineer  _____ Signature Date		Approved by: G. C. Min /President  _____ Signature Date	
Other Aspects:			
Abbreviations:	• OK, Pass=passed • Fail=failed • N/A=not applicable		
⚠ <ul style="list-style-type: none"> ▪ This test report is not permitted to copy partly without our permission. ▪ This test result is dependent on only equipment to be used. ▪ This test result is based on a single evaluation of one sample of the above mentioned. ▪ This test report must not be used by the client to claim product endorsement by NVLAP or any agency of the U.S Government. ▪ We certify this test report has been based on the measurement standards that is traceable to the national or international standards. 			



»» Contents ««

Contents	2
List of Tables	2
List of Figures	2
List of Photographs	2
1. General	3
2. Test Site	3
2.1 Location	3
2.2 List of Test and Measurement Instruments	4
2.3 Test Data	4
2.4 Test Environment	4
3. Description of the tested samples	5
3.1 Rating and Physical characteristics	5
3.2 Submitted documents	5
4. Measurement conditions	6
4.1 Modes of operation	6
4.2 List of peripherals	6
4.3 Uncertainty	6
4.4 Test Setup	7
5. Emission Test	8
5.1 Conducted Emissions	8
5.2 Radiated Emissions	12
6. Photographs of the Test Set-up	14
Annex1 Label	16
Annex2 Photographs of EUT	18~21
» List of Tables	
Table 1 List of test and measurement equipment	4
Table 2 Test Data. Conducted Emissions	11
Table 3 Test Data. Radiated Emissions	13
» List of Figures	
Figure 1 Spectral Diagram, LINE-PE	9
Figure 2 Spectral Diagram, Neutral-PE	10
» List of Photographs	
Photograph 1 Setup for Radiated Emissions	14
Photograph 2 Setup for Conducted Emissions	15



1. General

This equipment has been shown to be capable of compliance with the applicable technical standards and was tested in accordance with the measurement procedures as indicated in this report.

We attest to the accuracy of data. Korea Technology Institute Co., Ltd. performed all measurements reported herein. And were made under Chief Engineer's supervisor.

We assume full responsibility for the completeness of these measurements and vouch for the qualifications of all persons taking them.

2. Test Site

Korea Technology Institute Co., Ltd.

Location

51-19, Sanglim3-Ri, Docheok-Myeun, Gwangju-Shi, Gyeongki-Do, Korea

The Test Site is in compliance with ANSI C63.4/2003 for measurement of radio Interference.



List of Test and Measurement Instruments

Table 1: List of Test and Measurement Equipment

• Conducted Emissions

Kind of Equipment	Type	S/N	Calibrated until
Field Strength Meter	ESIB40	100093	07.2008
LISN	KNW407	8-1157-2	05.2009
LISN	EM-7823	115019	05.2009
Conducted Cable	N/A	N/A	11.2008

• Radiated Emissions

Kind of Equipment	Type	S/N	Calibrated until
Field Strength Meter	ESIB40	100093	07.2008
Biconic Logarithmic PeriodicAntenna	VULB9163	9163-281	09.2008
Horn Antenna	3115	6443	07.2008
Open Site Cable	N/A	N/A	11.2009
Antenna Mast	DETT-03	N/A	N/A
Antenna & Turntable controller	DETT-04	91X519	N/A

Test Date

Date of Application: June 10, 2008

Date of Test: June 23, 2008

Test Environment

Indoor: 25°C/39%/1000mbar

Outdoor: 27.1°C/23%/1000mbar



3. Description of the tested samples

The EUT is 15" TFT LCD Touch Monitor.

Rating and Physical Characteristics

Part	Specifications
LCD	15"viewable, Diagonal, Pixel pitch 0.29 mm, A-Si TFT
Display area	304.1(H) x 228.1(V) mm
Number of color	16.2 million colors
Input signals	R.G.B Analog, 15 pin D-sub / Digital TMDS(DVI-D)
Frequency rate	Horizontal: 31.0 to 60.0kHz, Vertical: 56 to 76Hz
Maximum bandwidth	65MHz
Maximum resolution	Analog: 1024 x 768@75Hz, Digital TMDS: 1024 x 768@75Hz
Recommended resolution	1024 x 768@60Hz
Input voltage	DC 12V, 3.0A
Power consumption	19W(Typ.)
Power management	VESA DPMS
Plug & Play	VESA DDC 1/2B
Audio system	2ch x 2watts / Ear Phone Jack
VESA FPMPMI	75 mm x 75 mm screw mounting
Operating Temperature	5 ~ 35 °C
Weight	2.75Kg unpacked, 4.1Kg packed
Dimensions (W x H x D mm)	348 x 340 x 185 mm

Submitted Documents

- User's Guide
- Block Diagram



4. Measurement Conditions

Testing Input Voltage: AC 220V

Modes of Operation

The EUT was in the following operation mode during all testing;

Prior to a measurement, the Instruments of education shall be operated until stabilization has been reached.

Additional Equipment

DEVICE TYPE	Manufacturer	M/N	S/N	FCC ID
PC	COMPAQ	EvoD5M	6F28KN8ZH110	DOC
Keyboard	COMPAQ	SK-2880	B943C0ADPS0ZL	DOC
Mouse	Logitech	M-UV96	265986-003	DOC
Mouse	SEJIN ELECTRON INC.	SMB-400	0CIM004047	GJJS965M3
Printer	HEWLETT PACKARD	C4569A	SG6A7160PJ	DOC

Uncertainty

1) Radiated disturbance

U_c (Combined standard Uncertainty) = $\pm 1.8\text{dB}$

Expanded uncertainty $U=KU_c$

$K = 2$

$\therefore U = \pm 3.6\text{dB}$

2) Conducted disturbance

$U_c = \pm 0.88\text{dB}$

$U = KU_c=2 \times U_c = \pm 1.8\text{dB}$



4.4 Test Setup

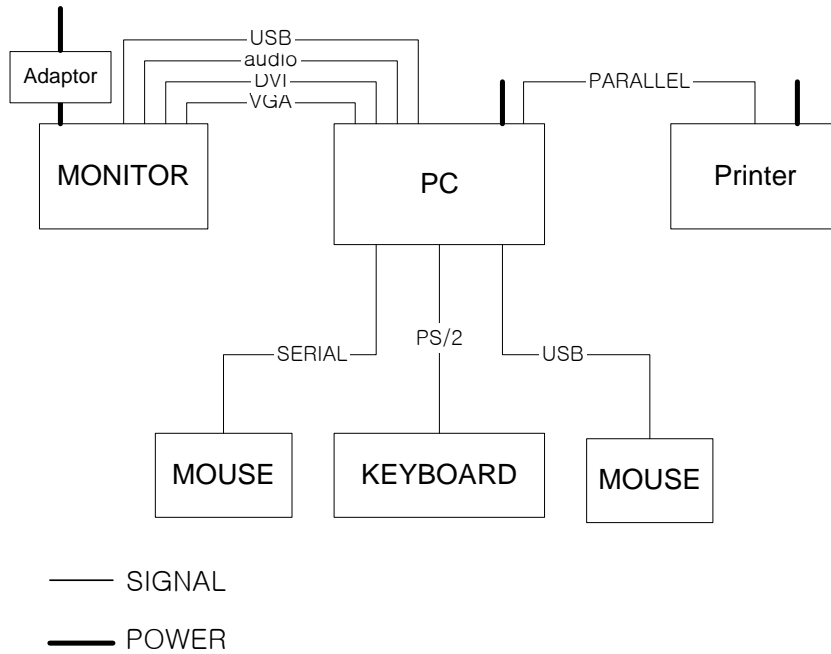



5. EMISSION Test

5.1. Conducted Emissions

Result:

Pass

The line-conducted facility is located inside a 2.3M x 3.5M x 5.5M shielded closure.

The shielding effectiveness of the shielded room is in accordance with MIL-Std-285 or NSA 605-05. A 1m x 1.5m wooden table 80cm high is placed 80cm away from the conducting ground plane and 40cm away from the sidewall of the shielded room. Electro-Metroics Model EM-7823 (9kHz-30MHz) 50ohm/50 uH Line-Impedance Stabilization Networks (LISN) are bonded to the shielded room.

The EUT is powered from the Electro-Metroics LISN and the support equipment is powered from the Kyoritsu LISN. Power to the LISN are filtered by a high-current high-insertion loss shield enclosures power line filters (100dB 14kHz-1GHz).

The purpose of the filter is to attenuate ambient signal interference and this filter is also bonded to the shielded enclosure.

All electrical cables are shielded by copper pipe with inner diameter of 1”.

If the EUT is a DC-Powered device, power will be derived from the source power supply it normally will be powered from and this supply lines will be connected to the Rohde & Schwarz LISN.

All interconnecting cables more than 1 meter were shortened by non-inductive bundling (serpentine fashion) to a 1-meter length.

Sufficient time for the EUT, Support equipment, and test equipment was allowed in order for them to warm up to their normal operating condition. The RF output of the LISN was connected to the spectrum analyzer to determine the frequency producing the maximum EME from the EUT.

The frequency producing the maximum level was reexamined using EMI field Intensity meter (ESIB40). The detector function was set to CISPR quasi-peak mode.

The bandwidth of the receiver was set to 10kHz. The EUT, support equipment, and interconnecting cables were arranged and manipulated to maximize each emission. Each emission was maximized by: switching power lines; varying the mode of operation or resolution; clock or data exchange speed; if applicable; whichever determined the worst-case emission.

Photographs of the worst-case emission can be seen in photograph of conducted test.

Each EME reported was calibrated using self-calibrating mode.



Figure 1: Spectral Diagram, LINE-PE

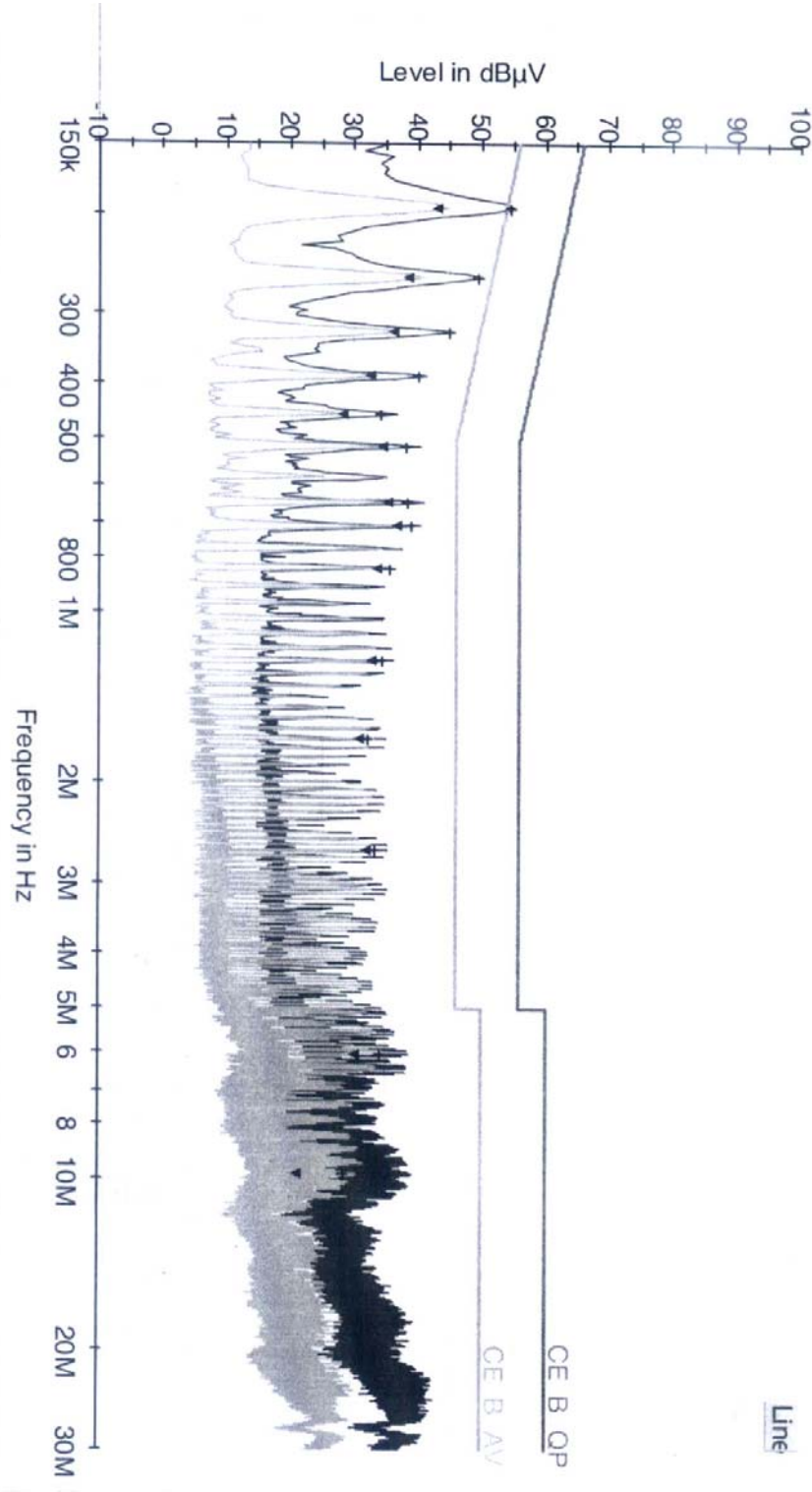



Figure 2: Spectral Diagram, NEUTRAL-PE

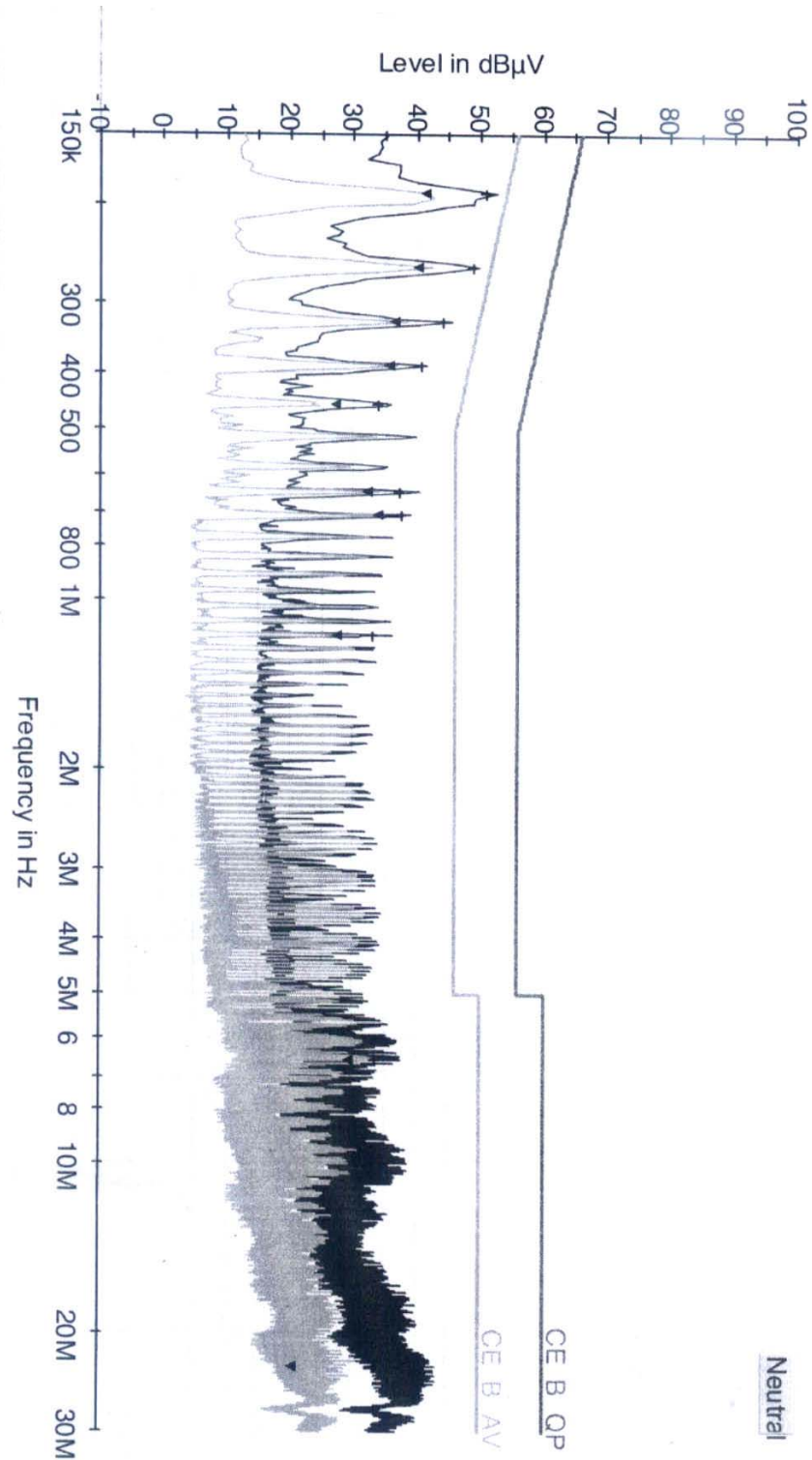



Table 2: Test Data, Conducted Emissions

Frequency (MHz)	(1) Reading (dBµV)	Line	(2)C/F (dB)	(3)Actual (dBµV)	(4) Limit (dBµV)	(5) Margin (dB)
0.19	54.53	L1	0.10	54.63	64.04	9.41
0.26	49.52	L1	0.10	49.62	61.43	11.81
0.32	44.96	L1	0.08	45.04	59.71	14.67
0.39	40.74	L2	0.09	40.83	58.06	17.23
0.64	38.47	L1	0.09	38.56	56.00	17.44
0.71	39.05	L1	0.10	39.15	56.00	16.85

NOTES:

1. All modes of operation were investigated
And the worst-case emissions are reported.
2. All other emissions are non-significant.
3. All readings are calibrated by self-mode in receiver.
4. Measurements using CISPR Quasi-peak mode.
5. L1 = LINE-PE, L2 = NEUTRAL-PE
6. C/F = Correction Factor(LISN factor + Cable loss)
7. The limit for Class B digital device is 66dBuV to 56dBuV from 150KHz to 500KHz, 56dBuV from 500KHz to 5MHz, 60dBuV Above 5MHz.

♣ Margin Calculation

(5) Margin = (4) Limit – (3) Actual

[(3) Actual = (1) Reading + (2) C/F]



5.2 Radiated Emissions

Result:

Pass

Preliminary measurements were made indoors at 1 meter using broadband antennas, broadband Amplifier, and spectrum analyzer to determine the frequency producing the maximum EME. Appropriate precaution was taken to ensure that all EME from the EUT were maximized and Investigated. The system configurations, clock speed, mode of operation or video resolution, turntable azimuth with respect to the antenna were noted for each frequency found. The spectrum was scanned from 30MHz to 1GHz using Biconic Logarithmic Periodic Antenna. Above 1GHz, Double ridged horn Antenna was used.

Final measurements were made outdoors at 3-meter test range using Schwarzbeck antennas. The test equipment was placed on a wooden table situated on a 4x4 meter area adjacent to the measurement area. Turntable was to protect from weather in the dome that made with Polyethylene film. Sufficient time for the EUT, support equipment, and test equipment was allowed in order for them to warm up to their normal operating condition. Each frequency found during pre-scan measurements was re-examined and investigated using EMI/Field Intensity Meter (ESIB40). The detector function was set to CISPR quasi-peak or peak mode as appropriate and the bandwidth of the receiver was set to 120kHz or 1 MHz depending on the frequency or type or signal.

The EUT, support equipment and interconnecting cables were re-configured to the set-up producing the maximum emission for the frequency and were placed on top of a 0.8meter high non-metallic 1 x 1.5 meter table.

The EUT, support equipment, and interconnecting cables were re-arranged and manipulated to maximize each EME emission. The turntable containing the system was rotated; the antenna height was varied 1 to 4 meters and stopped at the azimuth or height producing the maximum emission. Each emission was maximized by: varying the mode of operation or resolution; clock or data exchange speed, and/or support equipment, if applicable; and changing the polarity of the antenna and rotating the EUT in turns with three orthogonal axes for portable devices, whichever determined the worst-case emission.

Photographs of the worst-case emission can be seen in photograph of radiated emission test.

Each EME reported was calibrated using self-calibrating mode.



Table 3: Test Data, Radiated Emissions

Frequency (MHz)	(1) Reading (dB μ V)	Pol	Hei(m)	(2) AFCL (dB/m)	(3) Total (dB μ V/m)	(4) Limit (dB μ V/m)	(5) Margin (dB)
48.36	19.0	V	1.05	13.40	32.40	40.00	7.60
74.68	20.2	V	1.08	8.25	28.45	40.00	11.55
149.36	21.4	V	1.12	9.98	31.38	43.50	12.12
213.84	13.7	H	2.94	14.39	28.09	43.50	15.41
522.80	18.9	V	1.13	22.72	41.62	46.00	4.38
896.20	12.3	V	1.02	29.56	41.86	46.00	4.14

* Radiated Measurements at 3-meters

Notes:

- 1.All modes of operation were investigated.
And the worst-case emissions are reported.
- 2.All other emission is non-significant.
- 3.All readings are calibrated by self-mode in receiver.
- 4.Measurements using CISPR quasi-peak mode.
- 5.AFCL = Antenna factor and cable loss
- 6.H = Horizontal, V = Vertical Polarization
7. The limit for Class B digital device is 100uV(40dBuV) from 30MHz to 88MHz, 150 uV (43.5dBuV) from 88MHz to 216MHz, 200uV(46dBuV) from 216MHz to 960MHz and 500 uV (54dBuV) from above 960MHz.

♣ **Margin Calculation**

(5) Margin = (4) Limit – (3) Total

[(3) Total = (1) Reading + (2) AFCL]