



HYUNDAI CALIBRATION & CERTIFICATION TECH. CO., LTD.

PRODUCT COMPLIANCE TEAM
SAN 136-1, AMI-RI, BUBAL-EUP, ICHEON-SI, KYOUNGKI-DO, 467-701, KOREA
TEL : +82 31 639 8518 FAX : +82 31 639 8525

CERTIFICATION

Manufacture;
IMAGEQUEST CO., LTD.

SAN 136-1, AMI-RI, BUBAL-EUP, ICHEON-SI,
KYOUNGKI-DO, 467-701, KOREA

IMAGEQUEST FRN : 0005-8664-39

Date of Issue: APRIL 9, 2002

Test Report No.: HCT-F02-0403

Test Site: HYUNDAI CALIBRATION & CERTIFICATION
TECHNOLOGIES CO., LTD.

HCT FRN : 0005-8664-21

FCC ID :

PJIC19F16110

MODEL / TYPE :

Q910

FCC Rule Part(s):

Part 15 & 2; ET Docket 95-19

Classification:

FCC Class B Peripheral Device (JBP)

Standard(s):

FCC Class B: 1998 (CISPR 22)

Equipment(EUT) Type:

19" CRT Monitor

Max Resolution:

1600 X 1200 Non-interlaced (@106.3KHz/ 85Hz)

Port/ Connector(s)

15-pin D-sub VGA connector

The device bearing the trade name and model specified above, has been shown to comply with the applicable technical standards as indicated in the measurement report and was tested in accordance with the measurement procedures specified in ANSI C63.4-1992.(See Test Report if any modifications were made for compliance)

I attest to the accuracy of data. All measurements reported herein were performed by me or were made under my supervision and are correct to the best of my knowledge and belief. I assume full responsibility for the completeness of these measurements and vouch for the qualifications of all persons taking them.

HYUNDAI C-Tech. certifies that no party to application has been denied the FCC benefits pursuant to Section 5301 of the Anti-Drug Abuse of 1988,21 U.S.C.853(a).

Report prepared by : Ki-Soo Kim
Manager of EMC Tech. Part



TABLE OF CONTENTS

	PAGE
1. GENERAL INFORMATION.....	3
1.1 Product Description.....	3
1.2 Related submittal(s)/Grant(s).....	3
1.3 Tested System Details.....	4
1.4 Test Methodology.....	4
1.5 Test Facility.....	4
2. SYSTEM TEST CONFIGURATION.....	5
2.1 Justification.....	5
2.2 EUT Exercise Software.....	5
2.3 Cable Description.....	5
2.4 Noise Suppression Parts on Cable.....	6
2.5 Equipment Modifications.....	6
2.6 Configuration of Tested System.....	7
3. PRELIMINARY TESTS.....	8
3.1 Power line Conducted Emissions Tests.....	9
3.2 Radiated Emissions Tests.....	9
4. FINAL CONDUCTED AND RADIATED EMISSION TESTS SUMMARY.....	9
4.1 Conducted Emission Tests.....	10
4.2 Radiated Emission Tests.....	11
5. FIELD STRENGTH CALCULATION.....	12
6. LIST OF TEST EQUIPMENT	13

ATTACHMENT A	ID Label / Location Info.
ATTACHMENT B.....	External Photos.
ATTACHMENT C	Block Diagram..
ATTACHMENT D	Test Setup Photos.
ATTACHMENT E	User's Manual.
ATTACHMENT F	Internal Photos.

1. GENERAL INFORMATION

1.1 Product Description

The ImageQuest CO., LTD. Model Q910 (referred to as the EUT in this report) is a 17" CRT Monitor with HOR. Freq. 106.3KHz (Max) and Resolution of 1600 X 1200 (Non-Interlaced). Product specification information described herein was obtained from product data sheet or user's manual.

CHASSIS TYPE	PLASTIC
LIST OF EACH OSC. OR XTAL. FREQ.(FREQ. 1MHz)	12MHz
POWER REQUIREMENT	100 - 240 VAC 2.5A 60/50Hz
NUMBER OF LAYERS	MAIN BOARD 1 LAYER CRT BOARD 1 LAYER OSD BOARD 1 LAYER
MAX. RESOLUTION	1600 X 1200 NON-INTERLACED(@106.3KHz/ 85Hz)
H-SYNC FREQUENCY RANGE	30KHz 107KHz
V-SYNC FREQUENCY RANGE	50Hz 150Hz
CRT TYPE	19" (CRT Type :M46QCK761X123)

1.2 Related Submittal(s) / Grant(s)

ORIGINAL SUBMITTAL ONLY

1.3 Tested System Details

The Model names for all equipment, plus descriptions used in the tested system (including inserted cards) are:

DEVICE TYPE	MANUFACTURER	MODEL NUMBER	FCC ID / DoC	CONNECTED TO
MONITOR (EUT)	IMAGEQUEST CO., LTD.	Q910	PJIC19F16110	HOST
PC(HOST)	H/P	DTPC-17	DoC	N/A
KEY BOARD	H/P	SK-2501-2D-K	GYUR385K	HOST
PRINTER	H/P	HP895C	DoC	HOST
MODEM	3COM CORPORATION	56K FAX MODEM	DoC	HOST
VIDEO CARD	MATROX	MIL2P/4G	DoC	HOST
MOUSE	H/P	M-S34	DZL211029	HOST

1.4 Test Methodology

Both conducted and radiated testing were performed according to the procedures in ANSI C63.4/1992. Radiated testing was performed at an antenna to EUT distance of 10 meters.

1.5 Test Facility

The open area test site and conducted measurement facility used to collect the radiated data are located at the 254-1, MAEKOK-RI, HOBUP-MYUN, ICHON-SI, KYOUNGKI-DO, 467-701, KOREA. The site is constructed in conformance with the requirements of ANSI C63.4 and CISPR Publication 22. Detailed description of test facility was submitted to the Commission and accepted dated July 24, 2000 (Confirmation Number: EA90661)

2.SYSTEM TEST CONFIGURATION

2.1 Justification

The device was configured for testing in a typical fashion (as a customer would normally use it). During the tests, the following components and I/O cards inside the E.U.T were used.

DEVICE TYPE	MANUFACTURE	MODEL/PART NUMBER
MAIN BOARD	ImageQuest CO., Ltd.	3040100893
CRT BOARD	ImageQuest CO., Ltd.	3040100894
OSD BOARD	ImageQuest CO., Ltd.	3040100894

2.2 EUT exercise Software

The EUT exercise program used during radiated and conducted testing was designed to exercise the various system components in a manner similar to a typical use. The software, contained on a 3-1/2 inch disc, was inserted into drive A and is auto starting on power-up. Once loaded, the program sequentially exercises each system component in turn. The sequence used is :(1) Display test, (2) RS 232 test (3) Key board test,(4) Printer test,(5) FDD test,(6) HDD test. The complete cycle takes about 20 seconds and is repeated continuously. As the keyboard and mouse are strictly input devices, no data is transmitted to them during test. They are however, continuously scanned for data input activity. The video resolution modes setup and change program was used during the radiated and conducted emission testing.

2.3 Cable Description

The marked "(D)" means the Data Cable and "(P)" means the Power Cable.

	Power Cord Shielded (Y/N)	I/O Cable Shielded (Y/N)	Length (M)
MONITOR(EUT)	N	Y	1.8(P), 1.5(D)
PC(HOST)	N	N/A	1.8(P)
PRINTER	N	Y	2.0(P),1.8(D)
KEY BOARD	N/A	Y	2.0(D)
MODEM	N	Y	2.0(P),0.8(D)
MOUSE	N/A	Y	1.8(D)

2.4 Noise Suppression Parts on Cable. (I/O CABLE)

	Ferrite Bead (Y/N)	Location	Metal Hood (Y/N)	Location
MONITOR(EUT)	Y	PC END	Y	PC END
PRINTER	Y	PC END	Y	BOTH END
KEY BOARD	Y	PC END	Y	PC END
MODEM	Y	PC END	Y	BOTH END
MOUSE	N	N/A	Y	PC END

2.5 Equipment Modifications

N/A

2.6 Configuration of Test system

Line Conducted Test : EUT was connected to LISN, all other supporting equipment were connected to another LISN.
 Preliminary Power line Conducted Emission tests were performed by using the procedure in ANSI C63.4/1992 7.2.3 to determine the worse operating conditions.

Radiated Emission Test : Preliminary Radiated Emissions tests were conducted using the procedure in ANSI C63.4/1992 8.3.1.1 to determine the worse operating condition. Final Radiated Emission tests were conducted at 10 meter open area test site.

[Configuration of Tested System]

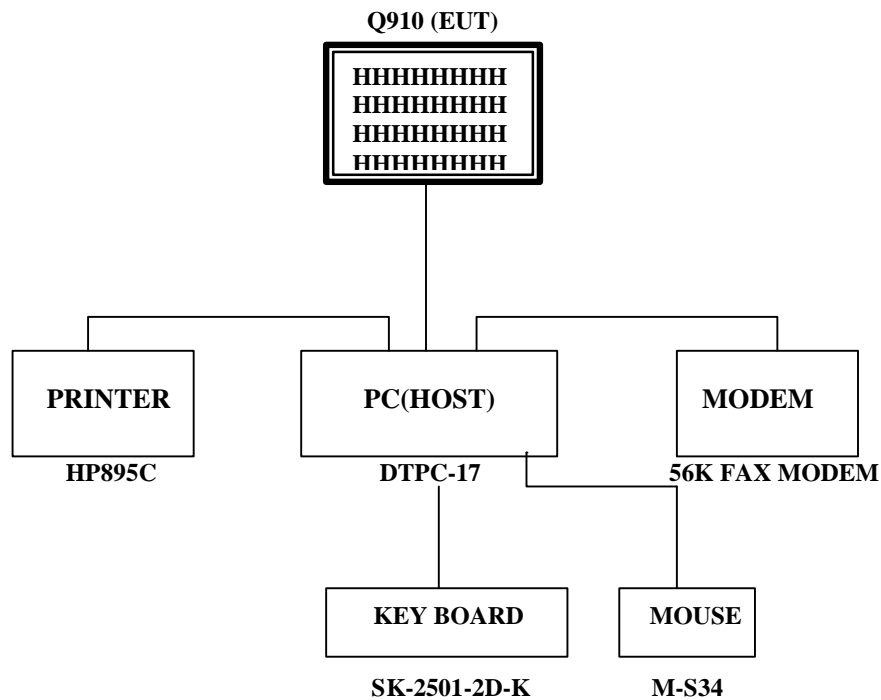

3. PRELIMINARY TESTS

3.1 AC Power line Conducted Emission Tests

During Preliminary Tests, the following operating mode were investigated

Processor Speed (MHz)	Video Resolution (w/max)	The worst operating condition
Pentium 350 MHz	1600 X 1200 Non-Interlaced (106.3KHz/85Hz)	X
	1280 X 1024 Non-Interlaced (91.1KHz/85Hz)	
	1024 x 768 Non-Interlaced (68.67KHz/85Hz)	
	800 x 600 Non-Interlaced (63.70KHz/120Hz))	
	640 x 480 Non-Interlaced (43.27KHz/85Hz)	

4.2 Radiated Emission Tests

During Preliminary Tests, the following operating mode were investigated

Processor Speed (MHz)	Video Resolution (w/max)	The worst operating condition
Pentium 350 MHz	1600 X 1200 Non-Interlaced (106.3KHz/85Hz)	X
	1280 X 1024 Non-Interlaced (91.1KHz/85Hz)	
	1024 x 768 Non-Interlaced (68.67KHz/85Hz)	
	800 x 600 Non-Interlaced (63.70KHz/120Hz))	
	640 x 480 Non-Interlaced (43.27KHz/85Hz)	

Tested by **Kyoung-Houn Seo / Engineer**

Date : **MARCH 12, 2002**

4. FINAL CONDUCTED AND RADIATED EMISSION TESTS SUMMARY

4.1 Conducted Emission Test

The following table shows the highest levels of conducted emissions on both polarization of hot and neutral line.

Humidity Level	: 35%	Temperature	: 22
Limit apply to	: CISPR 22		
Type of Tests	: CLASS B		
Date	: MARCH 16, 2002		
Result	: PASSED BY		-4.2 dB

EUT	: 19" CRT MONITOR
Operating Condition	: 1600 X 1200 Non-Interlaced (Hf : 106.3KHz, Vf : 85Hz)
Detector	: CISPR Quasi-Peak (6 dB Bandwidth : 9 KHz) CISPR Average(6 dB Bandwidth : 9 KHz)

Line Conducted Emission Tabulated Data

Power Line Conducted Emissions			CISPR 22		
Frequency (MHz)	Amplitude (dBuV)	Conductor	Limit (dBuV)	Margin (dB)	Detector Mode
14.995	45.8	NEUTRAL	50.0	-4.2	Average
15.205	44.8	NEUTRAL	50.0	-5.2	Average
14.890	43.5	NEUTRAL	50.0	-6.5	Average
14.995	43.2	HOT	50.0	-6.8	Average

NOET:

- All video modes and resolutions were investigated and the worst-case emissions are reported
Other video modes & resolution were tested and found to be in compliance.

Measured by : **Kyoung-Houn Seo / Engineer**

Date : **MARCH 16, 2002**

HYUNDAI C-TECH. CO., LTD.
EMC TEST LAB.

EUT: Q910
 Manufacturer: IMAGEQUEST
 Operating Condition: 1600 X 1200 106K 85Hz
 Test Site: Shield Room
 Operator: KH-SEO
 Test Specification: EN 55022
 Comment: N
 Start of Test: 3/16/02 / 5:02:11AM

SCAN TABLE: "EN 55022 Voltage"

Short Description: EN 55022 Voltage
 Start Stop Step Detector Meas. IF Transducer
 Frequency Frequency Width Time Bandw.
 150.0 kHz 30.0 MHz 5.0 kHz MaxPeak 10.0 ms 9 kHz old-C/E FACTOR
 Average

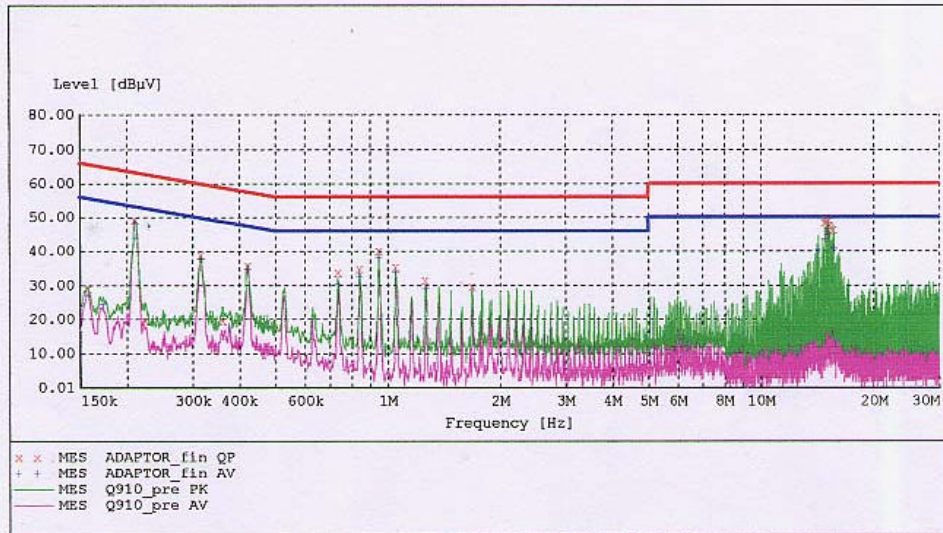

MEASUREMENT RESULT: "ADAPTOR_fin_QP"

3/16/02 5:05AM

Frequency MHz	Level dBµV	Transd dB	Limit dBµV	Margin dB	Line	PE
0.158000	29.10	1.0	66	36.5	1	---
0.211000	49.10	1.0	63	14.1	1	---
0.225000	19.60	1.0	63	43.0	1	---
0.317000	39.00	1.0	60	20.8	1	---
0.363000	19.60	1.0	59	39.0	1	---
0.423000	35.80	1.0	57	21.6	1	---
0.740000	33.70	1.0	56	22.3	1	---
0.845000	34.90	1.0	56	21.1	1	---
0.950000	40.20	1.0	56	15.8	1	---
1.055000	35.40	1.0	56	20.6	1	---
1.265000	31.60	1.1	56	24.4	1	---
1.690000	29.80	1.2	56	26.2	1	---
14.890000	48.40	1.7	60	11.6	1	---
14.995000	50.00	1.7	60	10.0	1	---

MEASUREMENT RESULT: "ADAPTOR_fin QP"
(continued)

Frequency MHz	Level dBuV	Transd dB	Limit dBuV	Margin dB	Line	PE
15.105000	46.00	1.7	60	14.0	1	---
15.205000	48.90	1.7	60	11.1	1	---
15.310000	47.60	1.7	60	12.4	1	---
15.630000	46.30	1.7	60	13.7	1	---

MEASUREMENT RESULT: "ADAPTOR_fin AV"

3/16/02 5:05AM

Frequency MHz	Level dBuV	Transd dB	Limit dBuV	Margin dB	Line	PE
0.158000	27.40	1.0	56	28.2	1	---
0.173000	24.70	1.0	55	30.2	1	---
0.211000	44.10	1.0	53	9.0	1	---
0.317000	38.00	1.0	50	11.8	1	---
0.377000	17.50	1.0	48	30.9	1	---
0.423000	34.70	1.0	47	12.7	1	---
0.740000	30.40	1.0	46	15.6	1	---
0.845000	32.50	1.0	46	13.5	1	---
0.950000	38.20	1.0	46	7.8	1	---
1.055000	34.00	1.0	46	12.0	1	---
1.265000	29.10	1.1	46	16.9	1	---
1.690000	28.50	1.2	46	17.5	1	---
14.255000	40.50	1.7	50	9.5	1	---
14.890000	43.50	1.7	50	6.5	1	---
14.995000	45.80	1.7	50	4.2	1	---
15.205000	44.80	1.7	50	5.2	1	---
15.630000	41.00	1.7	50	9.0	1	---
15.735000	40.70	1.7	50	9.3	1	---

HYUNDAI C-TECH. CO., LTD.
EMC TEST LAB.

EUT: Q910
 Manufacturer: IMAGEQUEST
 Operating Condition: 1600 X 1200 106K 85Hz
 Test Site: Shield Room
 Operator: KH-SEO
 Test Specification: EN 55022
 Comment: H
 Start of Test: 3/16/02 / 4:55:57AM

SCAN TABLE: "EN 55022 Voltage"

Short Description: EN 55022 Voltage
 Start Stop Step Detector Meas. IF Transducer
 Frequency Frequency Width Time Bandw.
 150.0 kHz 30.0 MHz 5.0 kHz MaxPeak 10.0 ms 9 kHz old-C/E FACTOR
 Average

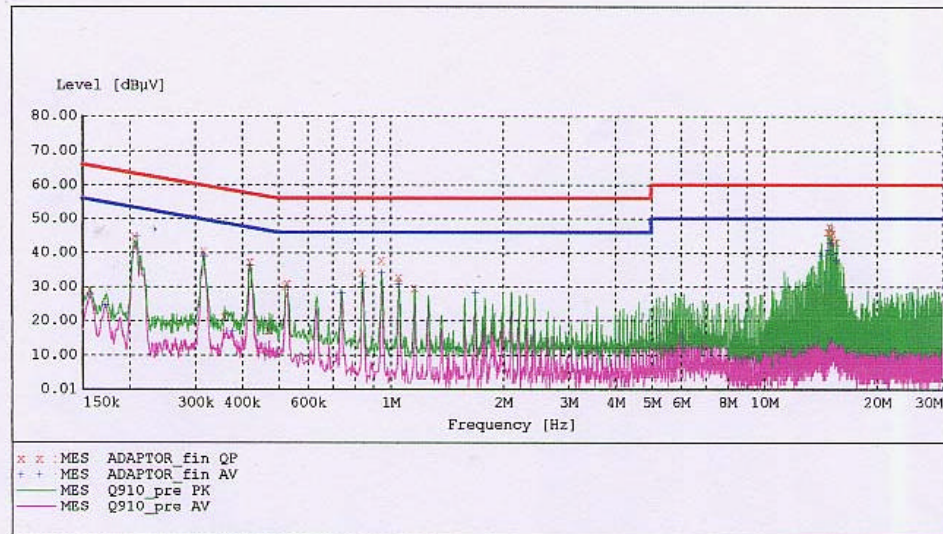

MEASUREMENT RESULT: "ADAPTOR_fin QP"

3/16/02 5:00AM

Frequency MHz	Level dBµV	Transd dB	Limit dBµV	Margin dB	Line	PE
0.157000	29.10	1.0	66	36.5	1	---
0.207000	44.90	1.0	63	18.4	1	---
0.317000	40.60	1.0	60	19.2	1	---
0.360000	21.30	1.0	59	37.4	1	---
0.422000	37.30	1.0	57	20.1	1	---
0.474000	17.30	1.0	56	39.2	1	---
0.525000	30.40	1.0	56	25.6	1	---
0.530000	31.20	1.0	56	24.8	1	---
0.845000	34.30	1.0	56	21.7	1	---
0.950000	37.70	1.0	56	18.3	1	---
1.055000	32.90	1.0	56	23.1	1	---
1.160000	29.80	1.1	56	26.2	1	---
14.890000	46.30	1.7	60	13.7	1	---
14.995000	47.80	1.7	60	12.2	1	---

MEASUREMENT RESULT: "ADAPTOR_fin QP"
(continued)

Frequency MHz	Level dBµV	Transd dB	Limit dBµV	Margin dB	Line	PE
15.105000	43.80	1.7	60	16.2	1	---
15.205000	46.90	1.7	60	13.1	1	---
15.310000	45.80	1.7	60	14.2	1	---
15.630000	43.40	1.7	60	16.6	1	---

MEASUREMENT RESULT: "ADAPTOR_fin AV"

3/16/02 5:01AM

Frequency MHz	Level dBµV	Transd dB	Limit dBµV	Margin dB	Line	PE
0.157000	27.70	1.0	56	27.9	1	---
0.173000	24.70	1.0	55	30.1	1	---
0.210000	44.80	1.0	53	8.4	1	---
0.317000	39.00	1.0	50	10.8	1	---
0.378000	17.10	1.0	48	31.2	1	---
0.422000	36.40	1.0	47	11.0	1	---
0.530000	29.90	1.0	46	16.1	1	---
0.740000	28.20	1.0	46	17.8	1	---
0.845000	31.10	1.0	46	14.9	1	---
0.950000	34.30	1.0	46	11.7	1	---
1.055000	31.00	1.0	46	15.0	1	---
1.690000	28.40	1.2	46	17.6	1	---
14.255000	39.40	1.7	50	10.6	1	---
14.890000	40.90	1.7	50	9.1	1	---
14.995000	43.20	1.7	50	6.8	1	---
15.105000	39.70	1.7	50	10.3	1	---
15.205000	42.90	1.7	50	7.1	1	---
15.630000	37.80	1.7	50	12.2	1	---

5. Field Strength Calculation

The field strength is calculated by adding the Antenna Factor and Cable Factor.

The basic equation with a sample calculation is as follows:

$$FS = RA + AF + CF$$

where FS = Field Strength

RA = Receiver Amplitude

AF = Antenna Factor

CF = Cable Attenuation Factor

Assume a receiver reading of 21.5 dBuV is obtained. The Antenna Factor of 7.4 and a Cable Factor of 1.1 is added. The 30 dBuV/m value was mathematically converted to its corresponding level in uV/m.

$$FS = 21.5 + 7.4 + 1.1 = 30 \text{ dBuV/m}$$

Level in uV/m = Common Antilogarithm [(30 dBuV/m)/20] = 31.6 uV/m

6. LIST OF TEST EQUIPMENT

<u>TYPE</u>	<u>MANUFACTURE</u>	<u>MODEL</u>	<u>CAL. DATE</u>
EMI Test Receiver	Rohde & Schwarz	ESH3	2001.6.29
EMI Test Receiver	Rohde & Schwarz	ESVP	2002.2.14
EMI Test Receiver	Rohde & Schwarz	ESI40	2001.11.5
EMI Test Receiver	Rohde & Schwarz	ESVS30	2002.3.6
Spectrum Monitor	Rohde & Schwarz	EZM	N.A
Graphic Plotter	Rohde & Schwarz	DOP2	N.A
Printer	Rohde & Schwarz	PDN	N.A
Spectrum Analyzer	H.P	8591EM	2001.7.11
LISN	EMCO	3825/2	2002.2.7
LISN	Rohde & Schwarz	ESH2-Z5	2001.8.12
Amplifier	Hewlett-Packard	8447E	2002.3.2
Dipole Antennas	Rohde & Schwarz	VHAP	2001.6.28
Dipole Antennas	Rohde & Schwarz	UHAP	2001.6.28
Biconical Antenna	Rohde & Schwarz	BBA-9106	2001.6.28
Log-Periodic Antenna	Rohde & Schwarz	UHALP-9107	2001.6.26
Antenna Position Tower	EMCO	1051-12	N.A
Turn Table	EMCO	1060-06	N.A
Line Filter	KEENE	ULW 2X30-60	N.A
Power Analyzer	Voltech	PM 3300	2002.2.20
Reference Network Impedance	Voltech	IEC 555	N.A
AC Power Source	PACIFIC	Magnetic Module	N.A
AC Power Source	PACIFIC	360AMX	N.A