



FCC PART 22/24 TEST REPORT

FCC Part 22 /Part 24

Report Reference No...... : **TRE1312005401 R/C: 30385**

FCC ID..... : **PJ7-1232**

Compiled by

(position+printed name+signature)..: File administrators Jerome Luo

Jerome Luo

Supervised by

(position+printed name+signature)..: Test Engineer Yuchao Wang

yuchao.wang

Approved by

(position+printed name+signature)..: Manager Wenliang Li

Wenliang Li

Date of issue..... : Jan 14, 2014

Testing Laboratory Name : **Shenzhen Huatongwei International Inspection Co., Ltd**

Address..... : Keji Nan No.12 Road, Hi-tech Park, Shenzhen, China

Applicant's name : **Shenzhen Neoway Technology Co.,Ltd**

Address..... : 4F-2#, Lianjian Science & Industry Park, Huarong Road, Dalang, Longhua new district, Shenzhen. P.R.C

Test specification

Standard : **FCC Part 22: PUBLIC MOBILE SERVICES**
FCC Part 24: PERSONAL COMMUNICATIONS SERVICES

TRF Originator..... : Shenzhen Huatongwei International Inspection CO., Ltd

Master TRF..... : Dated 2006-06

Shenzhen Huatongwei International Inspection Co., Ltd. All rights reserved.

This publication may be reproduced in whole or in part for non-commercial purposes as long as the Shenzhen Huatongwei International Inspection Co., Ltd is acknowledged as copyright owner and source of the material. Shenzhen Huatongwei International Inspection Co., Ltd takes no responsibility for and will not assume liability for damages resulting from the reader's interpretation of the reproduced material due to its placement and context.

Test item description : GPRS Module

Trade Mark : **neoway**

Manufacturer..... : **Shenzhen Eternity Technology Co.,Ltd**

Model/Type reference..... : M680

Listed Models : /

Ratings..... : DC 3.90V

Modulation : GMSK for GSM/GPRS/EDGE

GPRS Class : 12

GPRS operation mode : Class B

Frequency Band : GPRS850/EDGE850/GPRS1900/EDGE1900

Result..... : **PASS**

TEST REPORT

Test Report No. :	TRE1312005401	Nov 23, 2013
		Date of issue

Equipment under Test : GPRS Module

Model /Type : M680

Listed Models : /

Applicant : **Shenzhen Neoway Technology Co.,Ltd**

Address : 4F-2#,Lianjian Science & Industry Park,Huarong Road,Dalang,Longhua new district,Shenzhen.P.R.C

Manufacturer : **Shenzhen Eternity Technology Co.,Ltd**

Address : Block A2,Yingzhan Industrial Zone, Longtian Community, KengziOffice,Pingshan New District,Shenzhen,Guangdong Province,P.R.China

Test Result	PASS
--------------------	-------------

The test report merely corresponds to the test sample.

It is not permitted to copy extracts of these test result without the written permission of the test laboratory.

Contents

1.	<u>TEST STANDARDS.....</u>	4
2.	<u>SUMMARY</u>	5
2.1.	General Remarks	5
2.2.	Product Description	5
2.3.	Equipment under Test	5
2.4.	Short description of the Equipment under Test (EUT)	5
2.5.	Internal Identification of AE used during the test	6
2.6.	Normal Accessory setting	6
2.7.	EUT configuration	6
2.8.	Related Submittal(s) / Grant (s)	6
2.9.	Modifications	6
2.10.	Note	6
3.	<u>TEST ENVIRONMENT.....</u>	7
3.1.	Address of the test laboratory	7
3.2.	Test Facility	7
3.3.	Environmental conditions	8
3.4.	Statement of the measurement uncertainty	8
3.5.	Test Description	8
3.6.	Equipments Used during the Test	9
4.	<u>TEST CONDITIONS AND RESULTS.....</u>	10
4.1.	Conducted Emissions Test	10
4.2.	OUTPUT POWER	12
4.3.	Radiated Spurious Emssion	17
4.4.	OCCUPIED BANDWIDTH	21
4.5.	EMISSION BANDWIDTH	29
4.6.	BAND EDGE COMPLIANCE	37
4.7.	Spurious Emssion on Antenna Port	43
4.8.	Frequency Stability Test	66
5.	<u>TEST SETUP PHOTOS OF THE EUT</u>	68
6.	<u>EXTERNAL AND INTERNAL PHOTOS OF THE EUT</u>	70

1. TEST STANDARDS

The tests were performed according to following standards:

[FCC Part 22 \(10-1-12 Edition\)](#): PRIVATE LAND MOBILE RADIO SERVICES.

[FCC Part 24\(10-1-12 Edition\)](#): PUBLIC MOBILE SERVICES

[TIA/EIA 603 D June 2010](#): Land Mobile FM or PM Communications Equipment Measurement and Performance Standards.

[FCC Part 2](#): FREQUENCY ALLOCA-TIONS AND RADIO TREATY MAT-TERS; GENERAL RULES AND REG-ULATIONS

[KDB971168 D01:201](#): Procedures for Compliance Measurement of the Fundamental Emission Power of Licensed Wideband (> 1 MHz) Digital Transmission Systems

[ANSI C63.4:2009](#): Methods of Measurement of Radio-Noise Emissions from Low-Voltage Electrical and Electronic Equipment in the Range of 9 kHz to 40 GHz

2. SUMMARY

2.1. General Remarks

Date of receipt of test sample	:	Dec12, 2013
Testing commenced on	:	Jan 13, 2014
Testing concluded on	:	Jan 14, 2014

2.2. Product Description

The **Shenzhen Neoway Technology Co.,Ltd**'s Model: M680 or the "EUT" as referred to in this report; more general information as follows, for more details, refer to the user's manual of the EUT.

Name of EUT	GPRS Module
Model Number	M680
FCC ID	PJ7-1232
Modulation Type	GMSK for GPRS/EDGE
Antenna Type	External
Voice Function	Not Supported Voice function
GSM/EDGE/GPRS	Supported GPRS/EDGE
Extreme temp. Tolerance	-40°C to +85°C
Extreme vol. Limits	3.50VDC to 4.30VDC (nominal: 3.90VDC)
GPRS/EGPRS Operation Frequency Band	GPRS850/EGPRS850/GPRS1900/EGPRS1900
GSM Release Version	R99
GPRS operation mode	Class B
GPRS Multislot Class	12
EGPRS Multislot Class	12

2.3. Equipment under Test

Power supply system utilised

Power supply voltage	:	<input type="radio"/> 120V / 60 Hz	<input type="radio"/> 115V / 60Hz
		<input type="radio"/> 12 V DC	<input type="radio"/> 24 V DC
		<input checked="" type="radio"/> Other (specified in blank below)	

DC 3.90V

Test frequency list

Modulation Type	Test Channel	Channel Number	Test Frequency
GPRS850/GSM850	Low	128	824.20 MHz
	Middle	188	836.60 MHz
	High	251	848.80 MHz
GPRS1900/GSM850	Low	512	1850.20 MHz
	Middle	661	1880.00 MHz
	High	810	1909.80 MHz

2.4. Short description of the Equipment under Test (EUT)

The Equipment Under Test (EUT) is a model of GPRS Module with external antenna. Manual and specifications of the EUT were provided to fulfil the test.

Samples undergoing test were selected by the Client.

2.5. Internal Identification of AE used during the test

AE ID*	Description

*AE ID: is used to identify the test sample in the lab internally.

2.6. Normal Accessory setting

Fully charged battery was used during the test.

2.7. EUT configuration

The following peripheral devices and interface cables were connected during the measurement:

- supplied by the manufacturer
- supplied by the lab

<input type="radio"/>	Power Cable	Length (m) :	/
		Shield :	/
		Detachable :	/
<input type="radio"/>	Multimeter	Manufacturer :	/
		Model No. :	/

2.8. Related Submittal(s) / Grant (s)

This submittal(s) (test report) is intended for **FCC ID:PJ7-1232** filing to comply with FCC Part 22 and Part 24 Rules.

2.9. Modifications

No modifications were implemented to meet testing criteria.

2.10. Note

1. The EUT is a GPRS Module, The functions of the EUT listed as below:

	Test Standards	Reference Report
GPRS/EDGE	FCC Part 22/FCC Part 24	TRE1312005401
MPE	FCC Part 2.1091(d)	TRE1312005402

3. TEST ENVIRONMENT

3.1. Address of the test laboratory

Shenzhen Huatongwei International Inspection Co., Ltd
Keji Nan No.12 Road, Hi-tech Park, Shenzhen, China
Phone: 86-755-26715686 Fax: 86-755-26748089

The sites are constructed in conformance with the requirements of ANSI C63.7, ANSI C63.4 (2009) and CISPR Publication 22.

3.2. Test Facility

The test facility is recognized, certified, or accredited by the following organizations:

CNAS-Lab Code: L1225

Shenzhen Huatongwei International Inspection Co., Ltd has been assessed and proved to be in compliance with CNAS-CL01 Accreditation Criteria for Testing and Calibration Laboratories (identical to ISO/IEC 17025: 2005 General Requirements) for the Competence of Testing and Calibration Laboratories, Date of Registration: Mar 01, 2012. Valid time is until Feb 28, 2015.

A2LA-Lab Cert. No. 2243.01

Shenzhen Huatongwei International Inspection Co., Ltd, EMC Laboratory has been accredited by A2LA for technical competence in the field of electrical testing, and proved to be in compliance with ISO/IEC 17025: 2005 General Requirements for the Competence of Testing and Calibration Laboratories and any additional program requirements in the identified field of testing. Valid time is until Sept 30, 2015.

FCC-Registration No.: 662850

Shenzhen Huatongwei International Inspection Co., Ltd, EMC Laboratory has been registered and fully described in a report filed with the FCC (Federal Communications Commission). The acceptance letter from the FCC is maintained in our files. Registration 662850, Renewal date June 01, 2015.

IC-Registration No.: 5377

The 3m Alternate Test Site of Shenzhen Huatongwei International Inspection Co., Ltd has been registered by Certification and Engineering Bureau of Industry Canada for the performance of radiated measurements with Registration No. 5377 on Dec 31, 2013. Valid time is until Dec 31, 2016.

ACA

Shenzhen Huatongwei International Inspection Co., Ltd, EMC Laboratory can also perform testing for the Australian C-Tick mark as a result of our A2LA accreditation.

VCCI

The 3m Semi-anechoic chamber (12.2m×7.95m×6.7m) and Shielded Room (8m×4m×3m) of Shenzhen Huatongwei International Inspection Co., Ltd has been registered in accordance with the Regulations for Voluntary Control Measures with Registration No.: R-2484. Date of Registration: December 20, 2012. Valid time is until December 19, 2015.

Main Ports Conducted Interference Measurement of Shenzhen Huatongwei International Inspection Co., Ltd has been registered in accordance with the Regulations for Voluntary Control Measures with Registration No.: C-2726. Date of Registration: December 20, 2012. Valid time is until December 19, 2015.

DNV

Shenzhen Huatongwei International Inspection Co Ltd has been found to comply with the requirements of DNV towards subcontractor of EMC and safety testing services in conjunction with the EMC and Low voltage Directives and in the voluntary field. The acceptance is based on a formal quality Audit and follow-ups according to relevant parts of ISO/IEC Guide 17025(2005), in accordance with the requirements of the DNV Laboratory Quality Manual towards subcontractors. Valid time is until Aug 24, 2016.

3.3. Environmental conditions

During the measurement the environmental conditions were within the listed ranges:

Temperature:	15-35 ° C
Humidity:	30-60 %
Atmospheric pressure:	950-1050mbar

3.4. Statement of the measurement uncertainty

The data and results referenced in this document are true and accurate. The reader is cautioned that there may be errors within the calibration limits of the equipment and facilities. The measurement uncertainty was calculated for all measurements listed in this test report acc. to CISPR 16 - 4 „Specification for radio disturbance and immunity measuring apparatus and methods – Part 4: Uncertainty in EMC Measurements“ and is documented in the Shenzhen Huatongwei International Inspection Co., Ltd quality system acc. to DIN EN ISO/IEC 17025. Furthermore, component and process variability of devices similar to that tested may result in additional deviation. The manufacturer has the sole responsibility of continued compliance of the device.

Hereafter the best measurement capability for Shenzhen Huatongwei laboratory is reported:

Test Items	Measurement Uncertainty	Notes
Frequency stability	25 Hz	(1)
Transmitter power conducted	0.57 dB	(1)
Transmitter power Radiated	2.20 dB	(1)
Conducted spurious emission 9KHz-12.75 GHz	1.60 dB	(1)
Conducted Emission 9KHz-30MHz	3.39 dB	(1)
Radiated Emission 30~1000MHz	4.24 dB	(1)
Radiated Emissio 1~18GHz	5.16 dB	(1)
Radiated Emissio 18-40GHz	5.54 dB	(1)
Occupied Bandwidth	-----	(1)
Emission Mask	-----	(1)
Modulation Characteristic	-----	(1)
Transmitter Frequency Behavior	-----	(1)

- (1) This uncertainty represents an expanded uncertainty expressed at approximately the 95% confidence level using a coverage factor of k=1.96.

3.5. Test Description

Test Items	Clause in FCC rules	Verdict
Conducted Emission	15.107/15.207	N/A
Output Power	22.913(a)/24.232(c)	PASS
Radiated Spurious Emission	2.1051/22.917/24.238	PASS
Frequency Stability	2.1055/24.235	PASS
Occupied Bandwidth	2.1049(h)(i)	PASS
Emission Bandwidth	22.917(b)/24.238(b)	PASS
Band Edge Compliance	22.917(b)/24.238(b)	PASS
Conducted Spurious Emission	2.1057/22.917/24.238	PASS

Remark:

1. The measurement uncertainty is not included in the test result.

3.6. Equipments Used during the Test

Output Power(Conducted) & Occupied Bandwidth & Emission Bandwidth & Band Edge Compliance & Conducted Spurious Emission					
No.	Equipment	Manufacturer	Model No.	Serial No.	Last Cal.
1	UNIVERSAL RADIO COMMUNICATION	Rohde&Schwarz	CMU200	112012	2013/10/26
2	Spectrum Analyzer	Rohde&Schwarz	FSU26	201141	2013/10/26
3	Splitter	Mini-Circuit	ZAPD-4	400059	2013/10/26

Frequency Stability					
No.	Equipment	Manufacturer	Model No.	Serial No.	Last Cal.
1	UNIVERSAL RADIO COMMUNICATION	Rohde&Schwarz	CMU200	112012	2013/10/26
2	Spectrum Analyzer	Rohde&Schwarz	FSU26	201141	2013/10/26
3	Climate Chamber	ESPEC	EL-10KA	05107008	2013/10/26
4	Splitter	Mini-Circuit	ZAPD-4	400059	2013/10/26

Output Power (Radiated) & Radiated Spurious Emission					
No.	Equipment	Manufacturer	Model No.	Serial No.	Last Cal.
1	UNIVERSAL RADIO COMMUNICATION	Rohde&Schwarz	CMU200	112012	2013/10/26
2	Spectrum Analyzer	Rohde&Schwarz	FSU26	201141	2013/10/26
3	HORN ANTENNA	ShwarzBeck	9120D	1012	2013/10/26
4	HORN ANTENNA	ShwarzBeck	9120D	1011	2013/10/26
5	Ultra-Broadband Antenna	ShwarzBeck	VULB9163	538	2013/10/26
6	Ultra-Broadband Antenna	ShwarzBeck	VULB9163	539	2013/10/26
7	TURNTABLE	MATURO	TT2.0	----	N/A
8	ANTENNA MAST	MATURO	TAM-4.0-P	----	N/A
9	EMI Test Software	Audix	E3	N/A	N/A
10	EMI Test Receiver	Rohde&Schwarz	ESIB 26	100009	2013/10/26
11	RF Test Panel	Rohde&Schwarz	TS / RSP	335015/ 0017	N/A
12	High pass filter	Compliance Direction systems	BSU-6	34202	2013/10/26
13	Splitter	Mini-Circuit	ZAPD-4	400059	2013/10/26
14	Horn Antenna	SCHWARZBECK	BBHA9170	25841	2013/10/26
15	Horn Antenna	SCHWARZBECK	BBHA9170	25842	2013/10/26
16	Preamplifier	ShwarzBeck	BBV 9718	BBV 9718	2013/10/26
17	Broadband Preamplifier	ShwarzBeck	BBV743	9743-0079	2013/10/26
18	Signal Generator	Rohde&Schwarz	SMF100A	101932	2013/10/26
19	Amplifier	Compliance Direction systems	PAP1-4060	120	2013/10/26
20	TURNTABLE	ETS	2088	2149	N/A
21	ANTENNA MAST	ETS	2075	2346	N/A
22	HORN ANTENNA	Rohde&Schwarz	HF906	100068	2013/10/26
23	HORN ANTENNA	Rohde&Schwarz	HF906	100039	2013/10/26

The calibration interval was one year.

4. TEST CONDITIONS AND RESULTS

4.1. Conducted Emissions Test

TEST APPLICABLE

The EUT was tested according to ANSI C63.4 - 2009. The frequency spectrum from 0.15 MHz to 30 MHz was investigated. The LISN used was 50 ohm / 50 u Henry as specified by section 5.1 of ANSI C63.4 - 2009. Cables and peripherals were moved to find the maximum emission levels for each frequency.

TEST CONFIGURATION

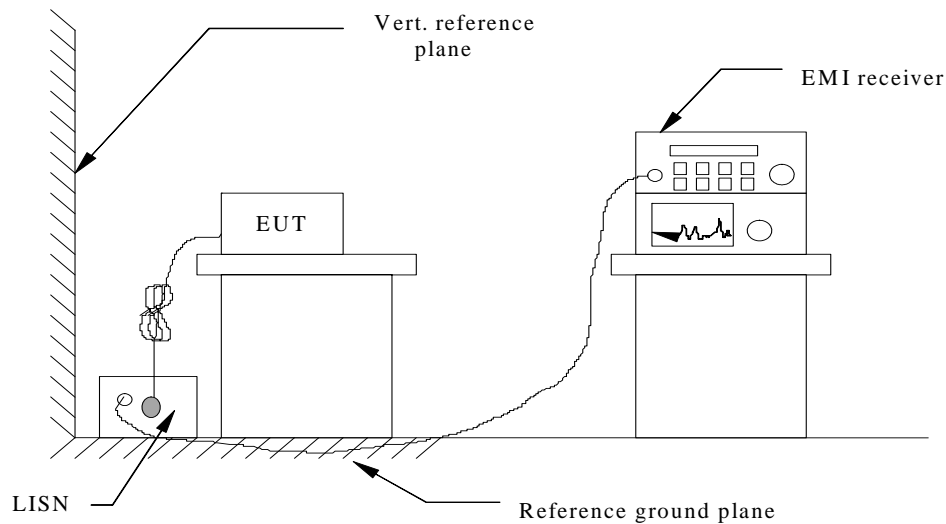

TEST PROCEDURE

- 1 The equipment was set up as per the test configuration to simulate typical actual usage per the user's manual. The EUT is a tabletop system; a wooden table with a height of 0.8 meters is used and is placed on the ground plane as per ANSI C63.4-2009.
- 2 Support equipment, if needed, was placed as per ANSI C63.4-2009.
- 3 All I/O cables were positioned to simulate typical actual usage as per ANSI C63.4-2009.
- 4 If EUT received DC power from the adapter, the adapter received AC120V/60Hz power through a Line Impedance Stabilization Network (LISN) which supplied power source and was grounded to the ground plane.
- 5 All support equipments received AC power from a second LISN, if any.
- 6 The EUT test program was started. Emissions were measured on each current carrying line of the EUT using a spectrum Analyzer / Receiver connected to the LISN powering the EUT. The LISN has two monitoring points: Line 1 (Hot Side) and Line 2 (Neutral Side). Two scans were taken: one with Line 1 connected to Analyzer / Receiver and Line 2 connected to a 50 ohm load; the second scan had Line 1 connected to a 50 ohm load and Line 2 connected to the Analyzer / Receiver.
- 7 Analyzer / Receiver scanned from 150 KHz to 30MHz for emissions in each of the test modes.
- 8 During the above scans, the emissions were maximized by cable manipulation.

Conducted Power Line Emission Limit

For unintentional device, according to § 15.107(a) Line Conducted Emission Limits is as following :

Frequency (MHz)	Maximum RF Line Voltage (dBµV)			
	CLASS A		CLASS B	
	Q.P.	Ave.	Q.P.	Ave.
0.15 - 0.50	79	66	66-56*	56-46*
0.50 - 5.00	73	60	56	46
5.00 - 30.0	73	60	60	50

* Decreasing linearly with the logarithm of the frequency

For intentional device, according to §15.207(a) Line Conducted Emission Limit is same as above table.

TEST RESULTS

N/A

4.2. OUTPUT POWER

TEST APPLICABLE

During the process of testing, the EUT was controlled via Rhode & Schwarz Digital Radio Communication tester (CMU-200) to ensure max power transmission and proper modulation. This result contains output power and EIRP measurements for the EUT. In all cases, output power is within the specified limits.

4.2.1. Conducted Output Power

TEST CONFIGURATION

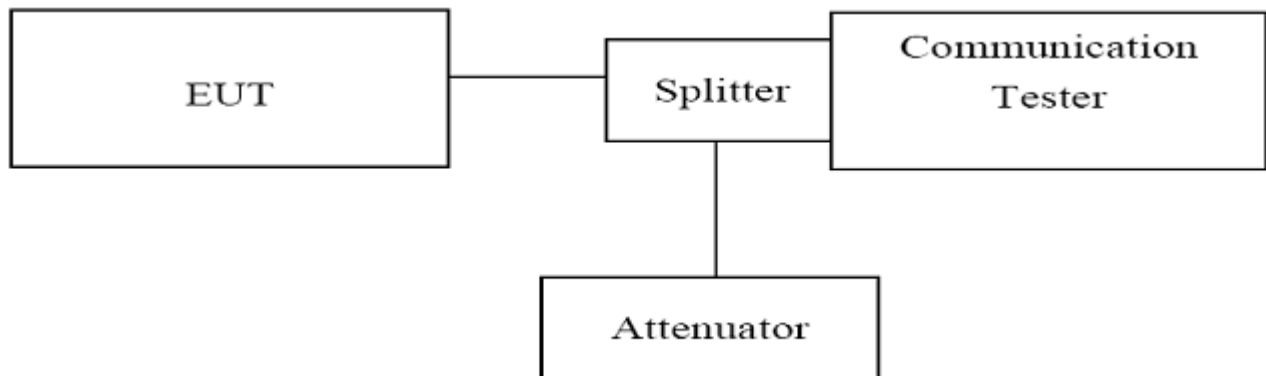

TEST PROCEDURE

1. The EUT was set up for the max output power with pseudo random data modulation.
2. The power was measured with Rhode & Schwarz Spectrum Analyzer FSU (peak)
3. These measurements were done at 3 frequencies, 1850.20 MHz, 1880.00 MHz and 1909.80 MHz for PCS1900 band; 824.20 MHz, 836.60 MHz and 848.80 MHz for GSM850 band. (low, middle and high of operational frequency range).

TEST CONDITION

RBW	VBW	Sweep Time	Span
1MHz	3MHz	300ms	10MHz

GSM850				
Function	Power step	Nominal Peak output power (dBm)	Power & Multislot class	Operation class
GSM	5	33dBm(2W)	4	/
GPRS	3	33dBm(2W)	12	B
EGPRS	3	33dBm(2W)	12	B

PCS1900				
Function	Power step	Nominal Peak output power (dBm)	Power & Multislot class	Operation class
GSM	0	30dBm(1W)	1	/
GPRS	3	30dBm(1W)	12	B
EGPRS	3	30dBm(1W)	12	B

TEST RESULTS

GPRS850(GMSK,1Slot)		
Frequency (MHz)	Power Step	Output Power (dBm)
824.20	3	31.69
836.60	3	31.85
848.80	3	32.24

EGPRS850(GMSK,1Slot)		
Frequency (MHz)	Power Step	Output Power (dBm)
824.20	3	31.68
836.60	3	31.89
848.80	3	32.25

GPRS1900(GMSK,1Slot)		
Frequency (MHz)	Power Step	Output Power (dBm)
1850.20	3	29.98
1880.00	3	29.80
1909.80	3	29.40

EGPRS1900(GMSK,1Slot)		
Frequency (MHz)	Power Step	Output Power (dBm)
1850.20	3	29.92
1880.00	3	29.81
1909.80	3	29.56

4.2.2. Radiated Output Power

TEST DESCRIPTION

This is the test for the maximum radiated power from the EUT.

Rule Part 24.232(c) specifies, "Mobile/portable stations are limited to 2 watts e.i.r.p. Peak power" and 24.232(e) specifies that "Peak transmit power must be measured over any interval of continuous transmission using instrumentation calibrated in terms of an rms-equivalent voltage." Rule Part 22.913(a) specifies "The ERP of mobile transmitters and auxiliary test transmitters must not exceed 7 Watts."

TEST CONFIGURATION

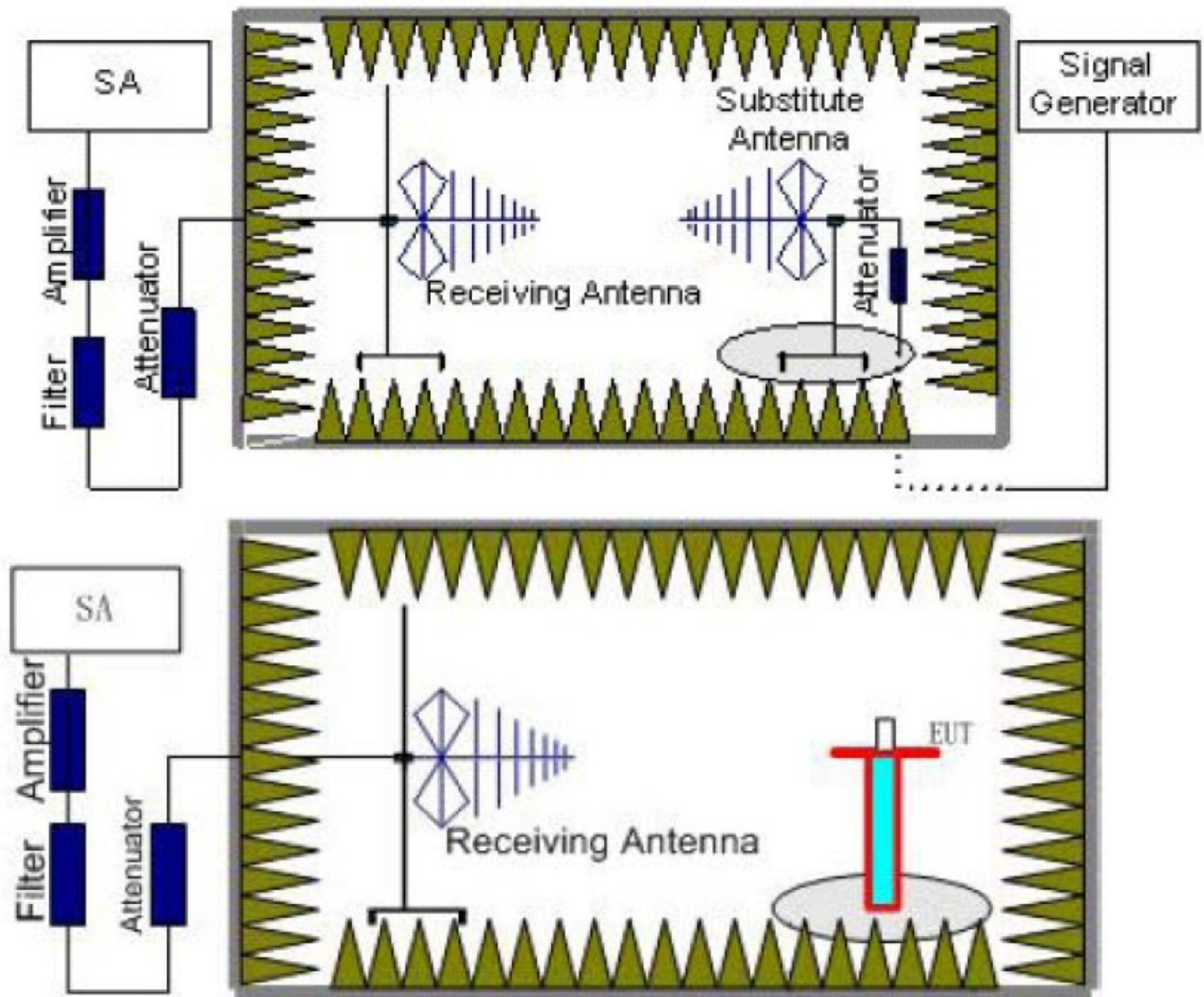

TEST PROCEDURE

1. EUT was placed on a 1.50 meter high non-conductive stand at a 3 meter test distance from the receive antenna. A receiving antenna was placed on the antenna mast 3 meters from the EUT for emission measurements. The height of receiving antenna is 1.50m. Detected emissions were maximized at each frequency by rotating the EUT through 360° and adjusting the receiving antenna polarization. The radiated emission measurements of all transmit frequencies in three channels (High, Middle, Low) were measured with peak detector.
2. A log-periodic antenna or double-ridged waveguide horn antenna shall be substituted in place of the EUT. The log-periodic antenna will be driven by a signal generator and the level will be adjusted till the same power value on the spectrum analyzer or receiver. The level of the spurious emissions can be calculated through the level of the signal generator, cable loss, the gain of the substitution antenna and the reading of the spectrum analyzer or receiver.

3. The EUT is then put into continuously transmitting mode at its maximum power level during the test. Set Test Receiver or Spectrum RBW=1MHz, VBW=3MHz, And the maximum value of the receiver should be recorded as (P_r).
4. The EUT shall be replaced by a substitution antenna. In the chamber, an substitution antenna for the frequency band of interest is placed at the reference point of the chamber. An RF Signal source for the frequency band of interest is connected to the substitution antenna with a cable that has been constructed to not interfere with the radiation pattern of the antenna. A power (P_{Mea}) is applied to the input of the substitution antenna, and adjust the level of the signal generator output until the value of the receiver reach the previously recorded (P_r). The power of signal source (P_{Mea}) is recorded. The test should be performed by rotating the test item and adjusting the receiving antenna polarization.
5. A amplifier should be connected to the Signal Source output port. And the cable should be connect between the Amplifier and the Substitution Antenna. The cable loss (P_{cl}), the Substitution Antenna Gain (G_a) and the Amplifier Gain (P_{Ag}) should be recorded after test. The measurement results are obtained as described below:

$$\text{Power(EIRP)} = P_{Mea} - P_{Ag} - P_{cl} + G_a$$
 We used SMF100A microwave signal generator which signal level can up to 33dBm, so we not used power Amplifier for substitution test; The measurement results are amend as described below:

$$\text{Power(EIRP)} = P_{Mea} - P_{cl} + G_a$$
6. This value is EIRP since the measurement is calibrated using an antenna of known gain (2.15 dBi) and known input power.
7. ERP can be calculated from EIRP by subtracting the gain of the dipole, $ERP = EIRP - 2.15\text{dBi}$.

TEST LIMIT

According to 22.913(a) and 24.232(c), the ERP should be not exceed following table limits:

GSM850(GPRS850,EDGE850)		
Function	Power Step	Burst Peak ERP (dBm)
GSM	5	$\leq 38.45\text{dBm}$ (7W)
GPRS	3	$\leq 38.45\text{dBm}$ (7W)
EGPRS	3	$\leq 38.45\text{dBm}$ (7W)

PCS1900(GPRS1900,EDGE1900)		
Function	Power Step	Burst Peak EIRP (dBm)
GSM	0	$\leq 33\text{dBm}$ (2W)
GPRS	3	$\leq 33\text{dBm}$ (2W)
EGPRS	3	$\leq 33\text{dBm}$ (2W)

TEST RESULTS

GPRS850						
Frequency (MHz)	P_{Mea} (dBm)	P_{cl} (dB)	G_a Antenna Gain (dB)	Correction (dB)	ERP (dBm)	Polarization
824.20	26.68	1.56	8.45	2.15	31.42	H
836.60	26.99	1.50	8.45	2.15	31.79	H
848.80	27.20	1.67	8.39	2.15	31.77	H
824.20	26.48	1.56	8.45	2.15	31.22	V
836.60	26.92	1.50	8.45	2.15	31.72	V
848.80	26.90	1.67	8.39	2.15	31.47	V

EGPRS850						
Frequency (MHz)	P_{Mea} (dBm)	P_{cl} (dB)	G_a Antenna Gain (dB)	Correction (dB)	ERP (dBm)	Polarization
824.20	26.67	1.56	8.45	2.15	31.41	H
836.60	27.03	1.50	8.45	2.15	31.83	H
848.80	27.21	1.67	8.39	2.15	31.78	H
824.20	26.47	1.56	8.45	2.15	31.21	V
836.60	26.96	1.50	8.45	2.15	31.76	V
848.80	26.91	1.67	8.39	2.15	31.48	V

GPRS1900						
Frequency (MHz)	P _{Mea} (dBm)	P _{cl} (dB)	G _a Antenna Gain (dB)	Correction (dB)	EIRP (dBm)	Polarization
1850.20	25.03	3.52	8.35	2.15	29.86	H
1880.00	25.21	3.61	8.29	2.15	29.89	H
1909.80	24.38	3.67	8.37	2.15	29.08	H
1850.20	24.83	3.52	8.35	2.15	29.66	V
1880.00	25.14	3.61	8.29	2.15	29.82	V
1909.80	24.08	3.67	8.37	2.15	29.78	V

EGPRS1900						
Frequency (MHz)	P _{Mea} (dBm)	P _{cl} (dB)	G _a Antenna Gain (dB)	Correction (dB)	EIRP (dBm)	Polarization
1850.20	24.97	3.52	8.35	2.15	29.80	H
1880.00	25.22	3.61	8.29	2.15	29.90	H
1909.80	24.54	3.67	8.37	2.15	29.24	H
1850.20	24.77	3.52	8.35	2.15	29.60	V
1880.00	25.15	3.61	8.29	2.15	29.83	V
1909.80	24.24	3.67	8.37	2.15	28.94	V

4.3. Radiated Spurious Emission

TEST APPLICABLE

According to the TIA/EIA 603D:2010 test method, The Receiver or Spectrum was scanned from 30 MHz to the 10th harmonic of the highest frequency generated within the equipment, which is the transmitted carrier that can be as high as 1910 MHz. The resolution bandwidth is set as outlined in Part 24.238 and Part 22.917. The spectrum is scanned with the mobile station transmitting at carrier frequencies that pertain to low, mid and high channels of PCS1900 and GSM850.

TEST CONFIGURATION

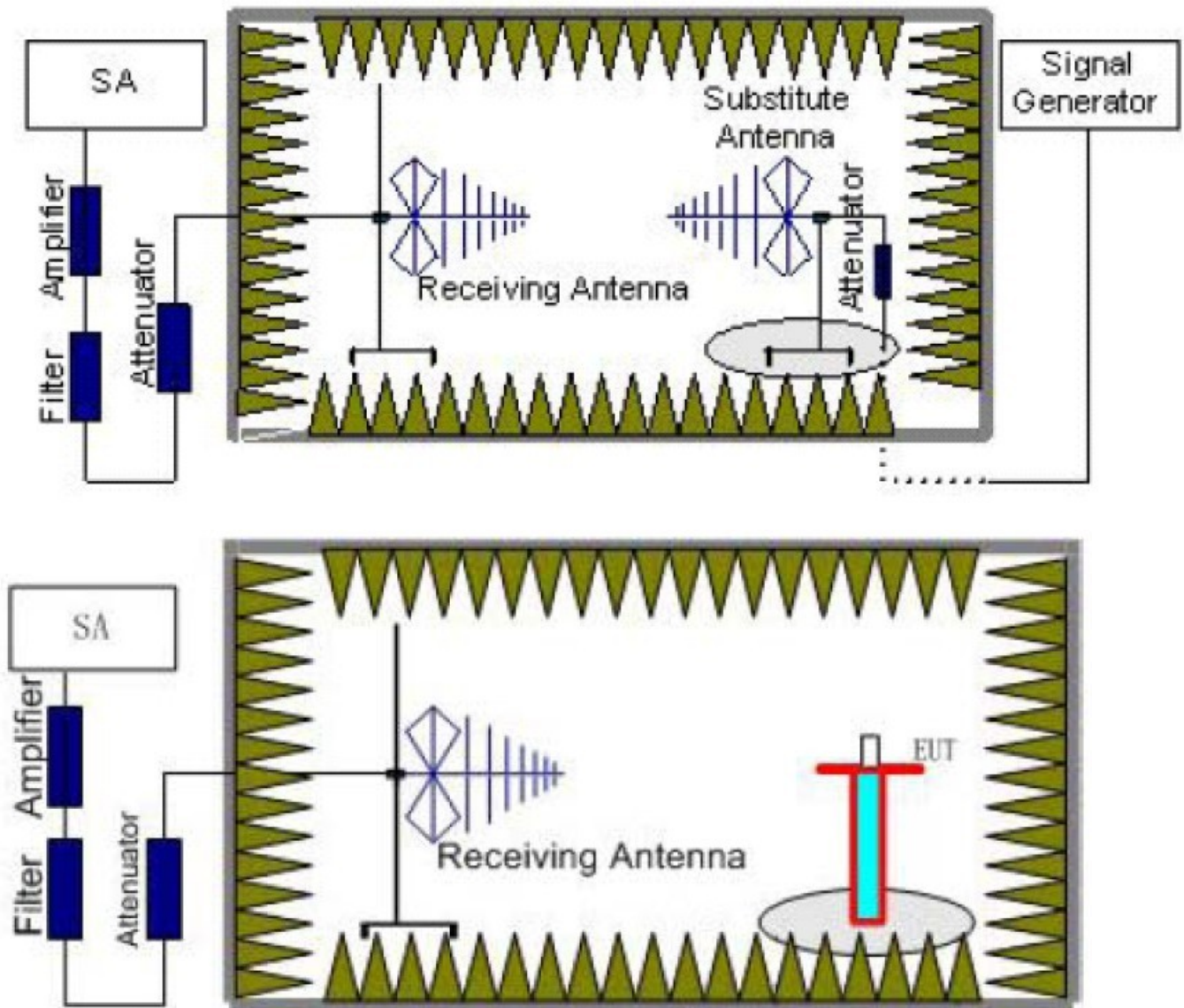

TEST PROCEDURE

1. EUT was placed on a 1.50 meter high non-conductive stand at a 3 meter test distance from the receive antenna. A receiving antenna was placed on the antenna mast 3 meters from the EUT for emission measurements. The height of receiving antenna is 1.50m. Detected emissions were maximized at each frequency by rotating the EUT through 360° and adjusting the receiving antenna polarization. The radiated emission measurements of all transmit frequencies in three channels (High, Middle, Low) were measured with peak detector.
2. A log-periodic antenna or double-ridged waveguide horn antenna shall be substituted in place of the EUT. The log-periodic antenna will be driven by a signal generator and the level will be adjusted till the same power value on the spectrum analyzer or receiver. The level of the spurious emissions can be calculated through the level of the signal generator, cable loss, the gain of the substitution antenna and the reading of the spectrum analyzer or receiver.

3. The EUT is then put into continuously transmitting mode at its maximum power level during the test. Set Test Receiver or Spectrum RBW=1MHz, VBW=3MHz, And the maximum value of the receiver should be recorded as (P_r).
4. The EUT shall be replaced by a substitution antenna. In the chamber, an substitution antenna for the frequency band of interest is placed at the reference point of the chamber. An RF Signal source for the frequency band of interest is connected to the substitution antenna with a cable that has been constructed to not interfere with the radiation pattern of the antenna. A power (P_{Mea}) is applied to the input of the substitution antenna, and adjust the level of the signal generator output until the value of the receiver reach the previously recorded (P_r). The power of signal source (P_{Mea}) is recorded. The test should be performed by rotating the test item and adjusting the receiving antenna polarization.
5. A amplifier should be connected to the Signal Source output port. And the cable should be connect between the Amplifier and the Substitution Antenna. The cable loss (P_{cl}), the Substitution Antenna Gain (G_a) and the Amplifier Gain (P_{Ag}) should be recorded after test. The measurement results are obtained as described below:
Power(EIRP)= $P_{Mea} - P_{Ag} - P_{cl} + G_a$
6. This value is EIRP since the measurement is calibrated using an antenna of known gain (2.15 dBi) and known input power.
7. ERP can be calculated from EIRP by subtracting the gain of the dipole, ERP = EIRP -2.15dBi.
8. In order to make sure test results more clearly, we set frequency range and sweep time for difference frequency range as follows table:

Working Frequency	Subrange (GHz)	RBW	VBW	Sweep time (s)
850MHz	0.03~1	100KHz	300KHz	10
	1-2	1 MHz	3 MHz	2
	2~5	1 MHz	3 MHz	3
	5~8	1 MHz	3 MHz	3
	8~10	1 MHz	3 MHz	3
1900MHz	0.03~1	100KHz	300KHz	10
	1-2	1 MHz	3 MHz	2
	2~5	1 MHz	3 MHz	3
	5~8	1 MHz	3 MHz	3
	8~11	1 MHz	3 MHz	3
	11~14	1 MHz	3 MHz	3
	14~18	1 MHz	3 MHz	3
18~20	1 MHz	3 MHz	2	

TEST LIMITS

According to 24.238 and 22.917 specify that the power of any emission outside of the authorized operating frequency ranges must be attenuated below the transmitting power (P) by a factor of at least $43 + 10 \log(P)$ dB.

The specification that emissions shall be attenuated below the transmitter power (P) by at least $43 + 10 \log(P)$ dB, translates in the relevant power range (1 to 0.001 W) to -13 dBm. At 1 W the specified minimum attenuation becomes 43 dB and relative to a 30 dBm (1 W) carrier becomes a limit of -13 dBm. At 0.001 W (0 dBm) the minimum attenuation is 13 dB, which again yields a limit of -13 dBm. In this way a translation of the specification from relative to absolute terms is carried out.

Frequency	Channel	Frequency Range	Verdict
GSM 850MHz	Low	30MHz-10GHz	PASS
	Middle	30MHz-10GHz	PASS
	High	30MHz-10GHz	PASS
GSM 1900MHz	Low	30MHz-20GHz	PASS
	Middle	30MHz-20GHz	PASS
	High	30MHz-20GHz	PASS

GPRS850							
Channel Number: 128				Test Frequency: 824.20 MHz			
Frequency (MHz)	P _{Mea} (dBm)	Path Loss	Antenna Gain	Correction (dB)	Peak ERP(dBm)	Limit (dBm)	Polarization
2475.45	-22.13	4.32	6.77	2.15	-21.83	-13.00	H
3293.71	-25.25	4.55	12.25	2.15	-19.70	-13.00	H
4944.71	-26.43	4.70	12.92	2.15	-20.36	-13.00	H
2475.45	-20.69	4.32	6.77	2.15	-20.39	-13.00	V
3298.21	-23.53	4.55	12.25	2.15	-17.98	-13.00	V
4116.53	-23.76	4.59	12.76	2.15	-17.74	-13.00	V

GPRS850							
Channel Number: 190				Test Frequency: 836.60 MHz			
Frequency (MHz)	P _{Mea} (dBm)	Path Loss	Antenna Gain	Correction (dB)	Peak ERP(dBm)	Limit (dBm)	Polarization
3343.86	-28.36	4.55	12.25	2.15	-22.81	-13.00	H
4186.45	-27.43	4.59	12.76	2.15	-21.41	-13.00	H
5017.03	-26.51	4.78	12.88	2.15	-20.56	-13.00	H
3345.27	-26.57	4.55	12.25	2.15	-21.02	-13.00	V
4185.67	-24.10	4.59	12.76	2.15	-18.08	-13.00	V
5016.94	-23.79	4.78	12.88	2.15	-17.84	-13.00	V

GPRS850							
Channel Number: 251				Test Frequency: 848.80 MHz			
Frequency (MHz)	P _{Mea} (dBm)	Path Loss	Antenna Gain	Correction (dB)	Peak ERP(dBm)	Limit (dBm)	Polarization
2548.83	-25.80	4.29	6.83	2.15	-25.41	-13.00	H
3392.75	-29.14	4.58	12.59	2.15	-23.28	-13.00	H
4235.82	-24.45	4.59	12.76	2.15	-18.43	-13.00	H
2549.93	-23.17	4.29	6.83	2.15	-22.78	-13.00	V
3393.20	-27.04	4.58	12.59	2.15	-21.18	-13.00	V
4234.15	-22.99	4.59	12.76	2.15	-16.97	-13.00	V

GPRS1900							
Channel Number: 512				Test Frequency: 1850.20 MHz			
Frequency (MHz)	P _{Mea} (dBm)	Path Loss	Antenna Gain	Correction (dB)	Peak ERP(dBm)	Limit (dBm)	Polarization
3704.61	-29.84	4.55	12.34	2.15	-24.20	-13.00	H
5553.81	-27.34	5.05	13.53	2.15	-21.01	-13.00	H
7405.82	-27.04	4.64	11.60	2.15	-22.23	-13.00	H
3704.24	-28.59	4.55	12.34	2.15	-22.95	-13.00	V
5554.25	-25.57	5.05	13.53	2.15	-19.24	-13.00	V
7406.92	-25.27	4.64	11.60	2.15	-20.46	-13.00	V

GPRS1900							
Channel Number: 661				Test Frequency: 1880.00 MHz			
Frequency (MHz)	P _{Mea} (dBm)	Path Loss	Antenna Gain	Correction (dB)	Peak ERP(dBm)	Limit (dBm)	Polarization
3768.95	-29.59	4.55	12.40	2.15	-23.89	-13.00	H
5646.85	-28.89	4.96	13.60	2.15	-22.40	-13.00	H
7528.10	-26.28	4.71	11.89	2.15	-21.25	-13.00	H
3764.94	-27.36	4.55	12.40	2.15	-21.66	-13.00	V
5645.14	-26.23	4.96	13.60	2.15	-19.74	-13.00	V
7524.32	-23.90	4.71	11.89	2.15	-18.87	-13.00	V

GPRS1900							
Channel Number: 810				Test Frequency: 1909.80 MHz			
Frequency (MHz)	P _{Mea} (dBm)	Path Loss	Antenna Gain	Correction (dB)	Peak ERP(dBm)	Limit (dBm)	Polarization
3824.21	-29.83	4.51	12.43	2.15	-24.06	-13.00	H
5735.80	-29.57	4.90	13.61	2.15	-23.01	-13.00	H
7641.69	-25.75	4.78	12.00	2.15	-20.68	-13.00	H
3823.38	-27.51	4.51	12.43	2.15	-21.74	-13.00	V
5734.75	-26.87	4.90	13.61	2.15	-20.31	-13.00	V
7635.90	-23.35	4.78	12.00	2.15	-18.28	-13.00	V

Note: 1. In general, the worse case attenuation requirement shown above was applied.

3. *** means that the emission level is too low to be measured or at least 20 dB down than the limit.

4.4. OCCUPIED BANDWIDTH

TEST APPLICABLE

Similar to conducted emissions; occupied bandwidth measurements are only provided for selected frequencies in order to reduce the amount of submitted data. Data were taken at the extreme and mid frequencies of PCS1900 band and GSM850 band. The table below lists the measured 99% BW.

TEST CONFIGURATION

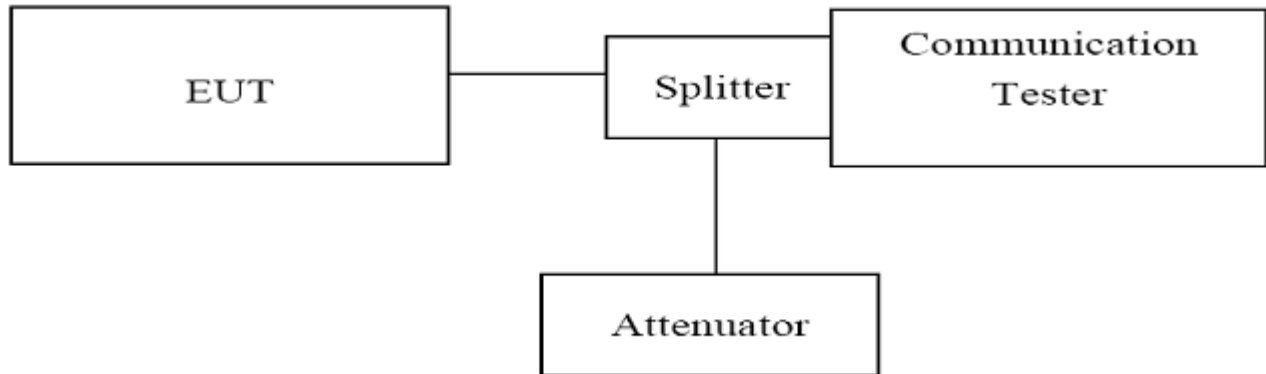

TEST PROCEDURE

1. The EUT was set up for the max output power with pseudo random data modulation;
2. The Occupied bandwidth was measured with Rhode & Schwarz Spectrum Analyzer FSU (peak);
3. Set RBW=5KHz,VBW=50KHz,Span=500KHz,SWT=20ms;
4. Set SPA Max hold. Mark peak, Set 99% Occupied Bandwidth
5. These measurements were done at 3 frequencies, 1850.20 MHz, 1880.00 MHz and 1909.80 MHz for PCS1900 band; 824.20MHz, 836.60 MHz and 848.80 MHz for GSM850 band. (low, middle and high of operational frequency range).

TEST RESULTS

GPRS850				
Channel Number	Frequency (MHz)	Occupied Bandwidth (99% BW) (kHz)	Refer to Plot	Verdict
128	824.20	241.99	Plot 4.4.1 A	PASS
190	836.60	243.59	Plot 4.4.1 B	PASS
251	848.80	244.39	Plot 4.4.1 C	PASS

EGPRS850				
Channel Number	Frequency (MHz)	Occupied Bandwidth (99% BW) (kHz)	Refer to Plot	Verdict
128	824.20	244.39	Plot 4.4.2 A	PASS
190	836.60	241.99	Plot 4.4.2 B	PASS
251	848.80	241.19	Plot 4.4.2 C	PASS



*RBW 5 kHz
*VBW 50 kHz
*SWT 20 ms

Marker 1 [T1]
25.51 dBm
824.202403846 MHz

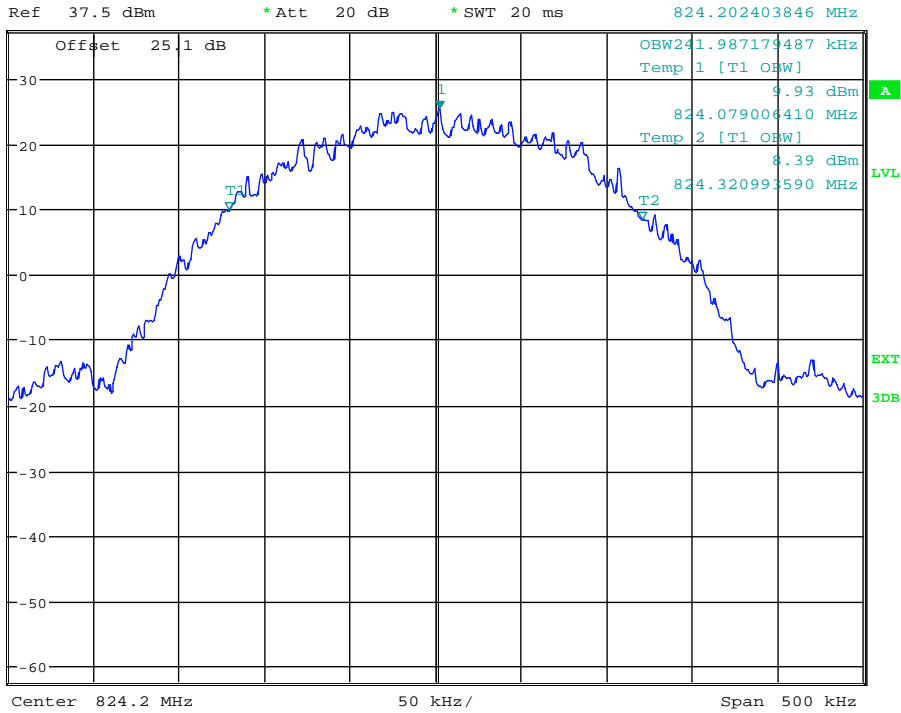

Date: 2.JAN.2014 15:43:44

(Plot 4.4.1 A: Channel 128: 824.20MHz @ GPRS850)



*RBW 5 kHz
*VBW 50 kHz
*SWT 20 ms

Marker 1 [T1]
25.35 dBm
836.575961538 MHz

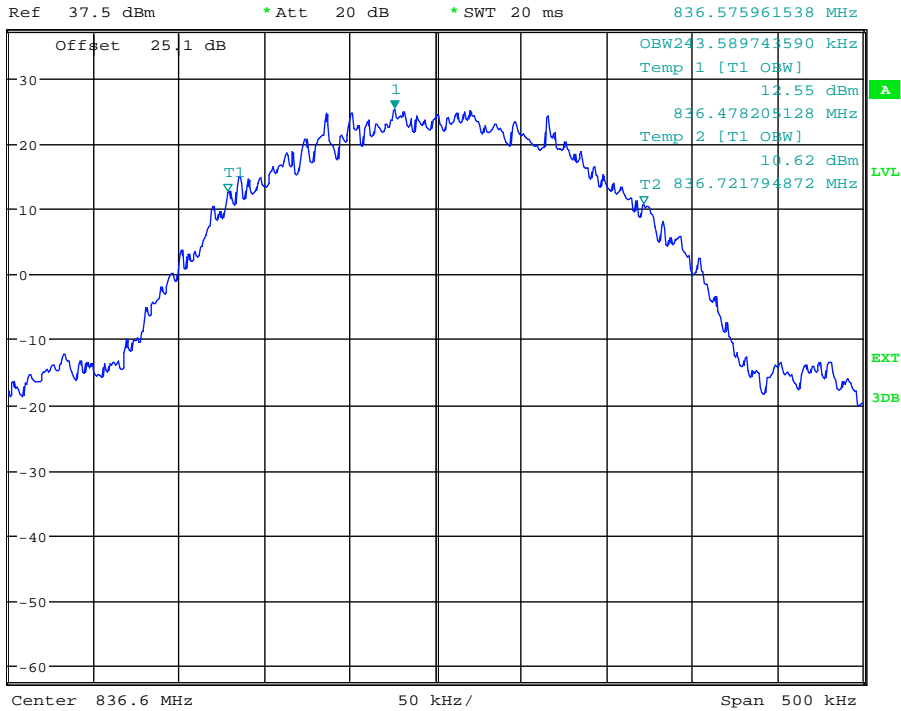

Date: 2.JAN.2014 15:43:15

(Plot 4.4.1 B: Channel 190: 836.60MHz @ GPRS850)

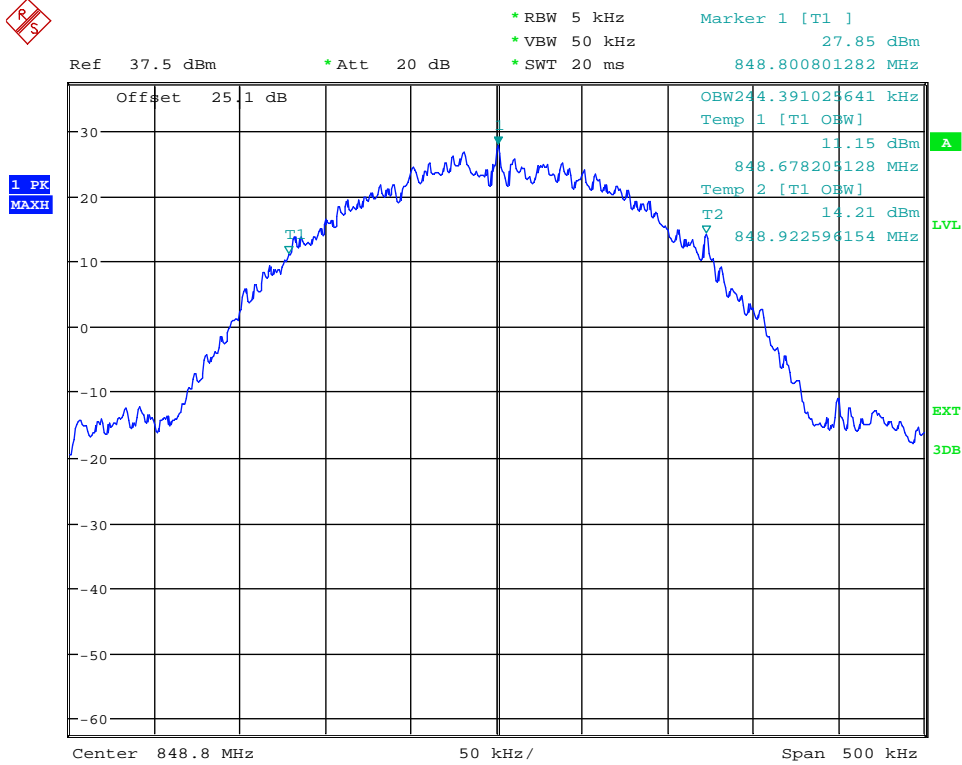

Date: 2.JAN.2014 15:42:46

(Plot 4.4.1 C: Channel 251: 848.80MHz @ GPRS850)

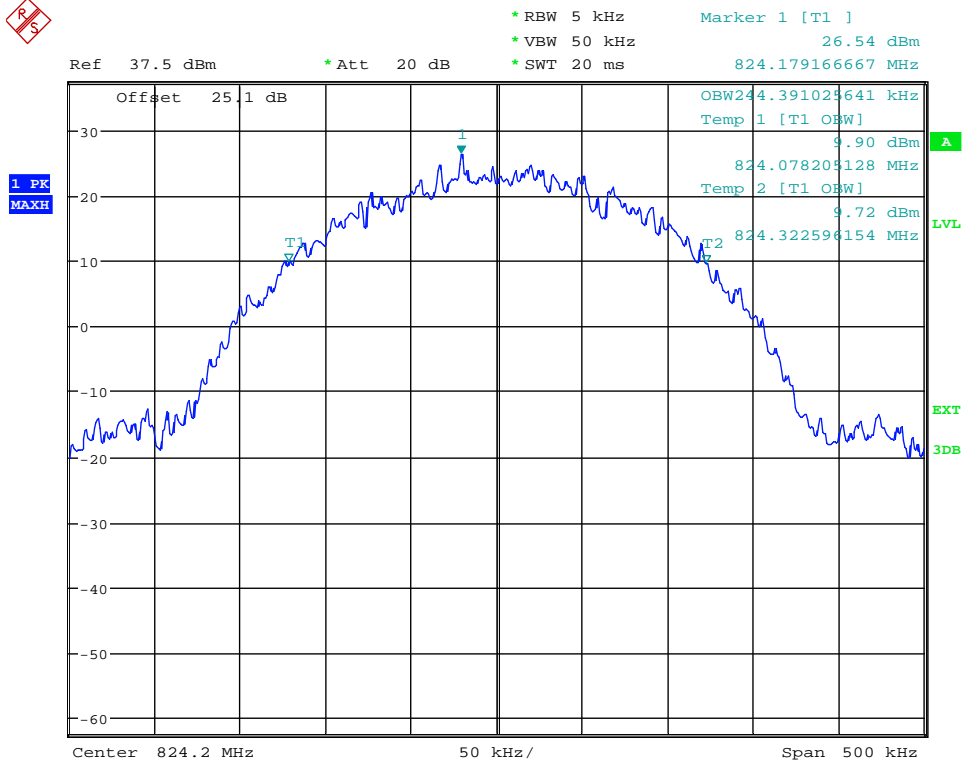

Date: 2.JAN.2014 16:02:08

(Plot 4.4.2 A: Channel 128: 824.20MHz @ EGPRS850)



*RBW 5 kHz Marker 1 [T1]
*VBW 50 kHz 24.88 dBm
*SWT 20 ms 836.623237179 MHz

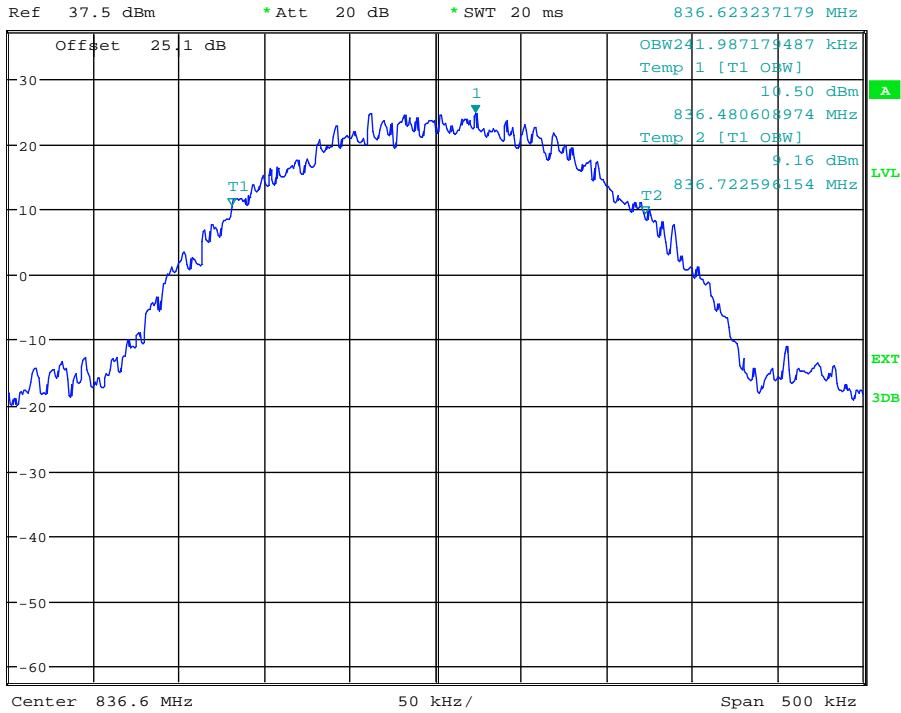

Date: 2.JAN.2014 16:01:47

(Plot 4.4.2 B: Channel 190: 836.60MHz @ EGPRS850)



*RBW 5 kHz Marker 1 [T1]
*VBW 50 kHz 25.90 dBm
*SWT 20 ms 848.764743590 MHz

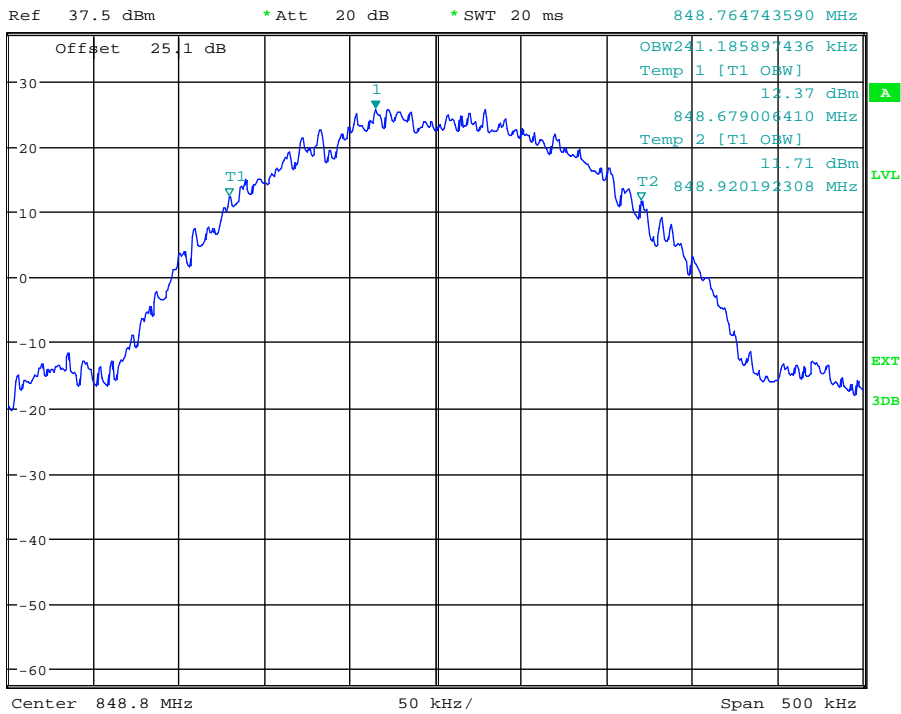

Date: 2.JAN.2014 16:01:21

(Plot 4.4.2 C: Channel 251: 848.80MHz @ EGPRS850)

GPRS1900				
Channel Number	Frequency (MHz)	Occupied Bandwidth (99% BW) (kHz)	Refer to Plot	Verdict
512	1850.20	241.99	Plot 4.4.3 A	PASS
661	1880.00	247.60	Plot 4.4.3 B	PASS
810	1909.80	241.99	Plot 4.4.3 C	PASS

EGPRS1900				
Channel Number	Frequency (MHz)	Occupied Bandwidth (99% BW) (kHz)	Refer to Plot	Verdict
512	1850.20	240.38	Plot 4.4.4 A	PASS
661	1880.00	246.79	Plot 4.4.4 B	PASS
810	1909.80	241.99	Plot 4.4.4 C	PASS

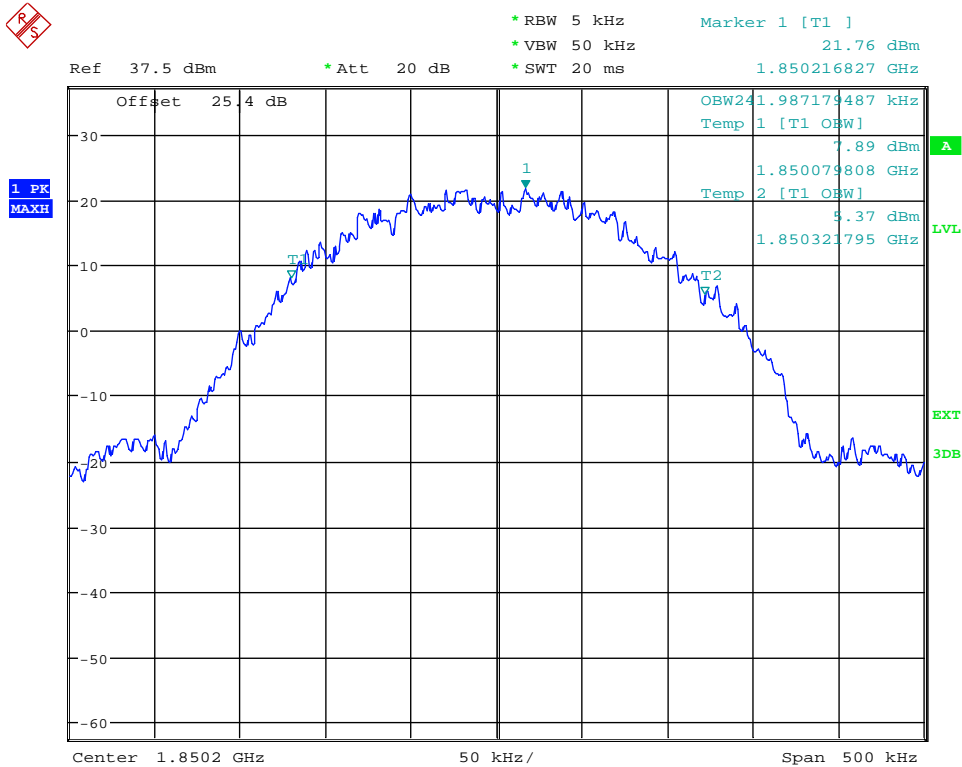

Date: 2.JAN.2014 16:15:35

(Plot 4.4.3 A: Channel 512:1850.20MHz @ GPRS1900)



Ref 37.5 dBm * Att 20 dB * RBW 5 kHz * VBW 50 kHz * SWT 20 ms Marker 1 [T1] 23.45 dBm 1.879998397 GHz

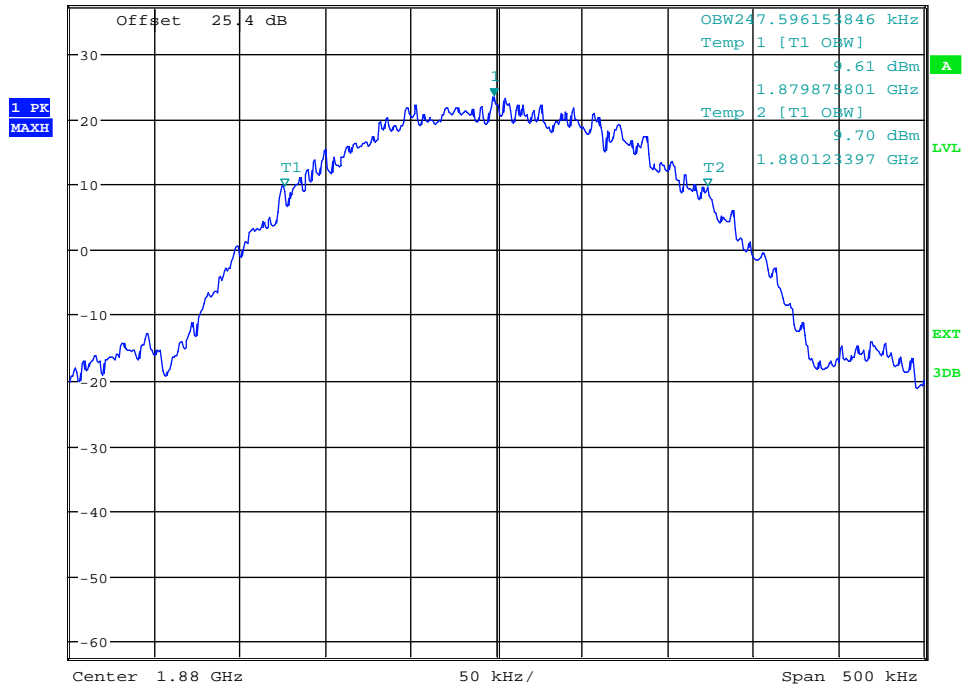

Date: 2.JAN.2014 16:15:14

(Plot 4.4.3 B: Channel 661:1880.00MHz @ GPRS1900)



Ref 37.5 dBm * Att 20 dB * RBW 5 kHz * VBW 50 kHz * SWT 20 ms Marker 1 [T1] 22.91 dBm 1.909803205 GHz

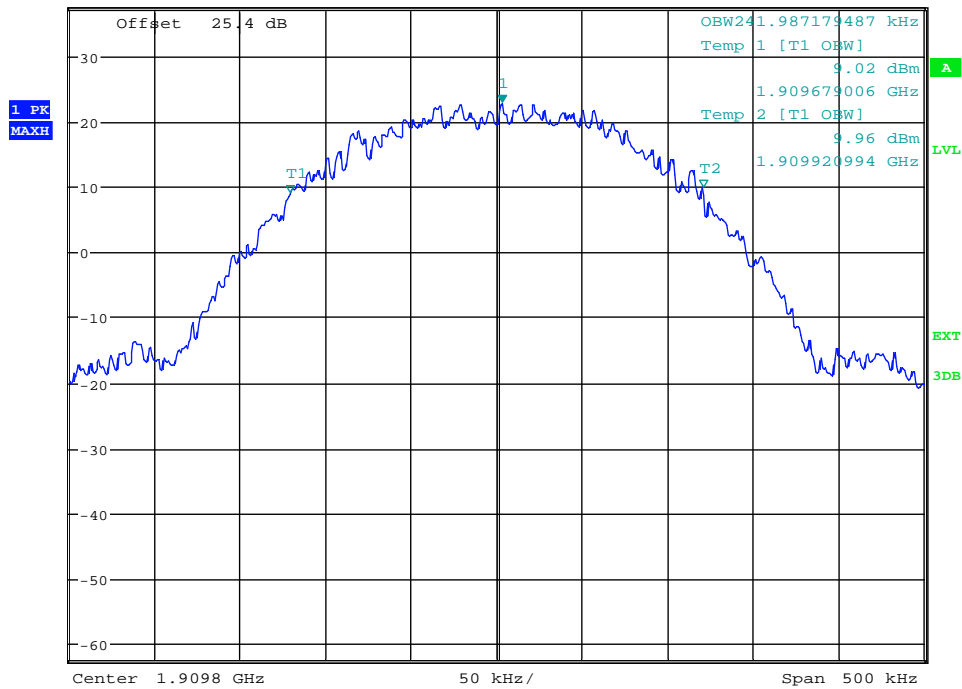

Date: 2.JAN.2014 16:14:48

(Plot 4.4.3 C: Channel 810:1909.80MHz @ GPRS1900)



Ref 37.5 dBm * Att 20 dB * RBW 5 kHz * VBW 50 kHz * SWT 20 ms Marker 1 [T1] 23.22 dBm 1.850201603 GHz

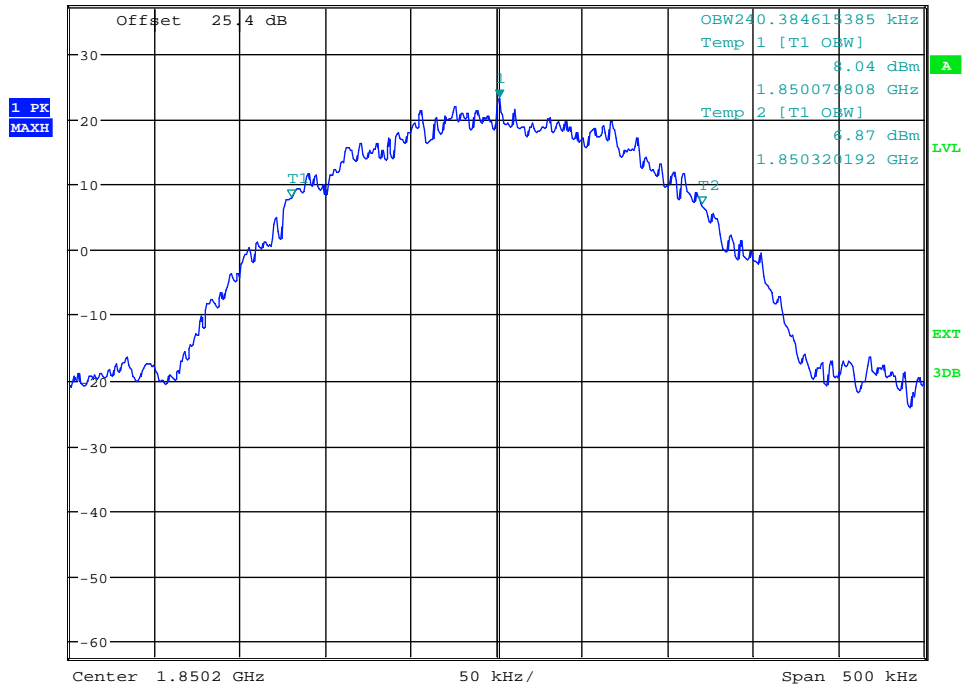

Date: 2.JAN.2014 16:42:54

(Plot 4.4.4 A: Channel 512:1820.20MHz @ EGPRS1900)



Ref 37.5 dBm * Att 20 dB * RBW 5 kHz * VBW 50 kHz * SWT 20 ms Marker 1 [T1] 23.90 dBm 1.879971955 GHz

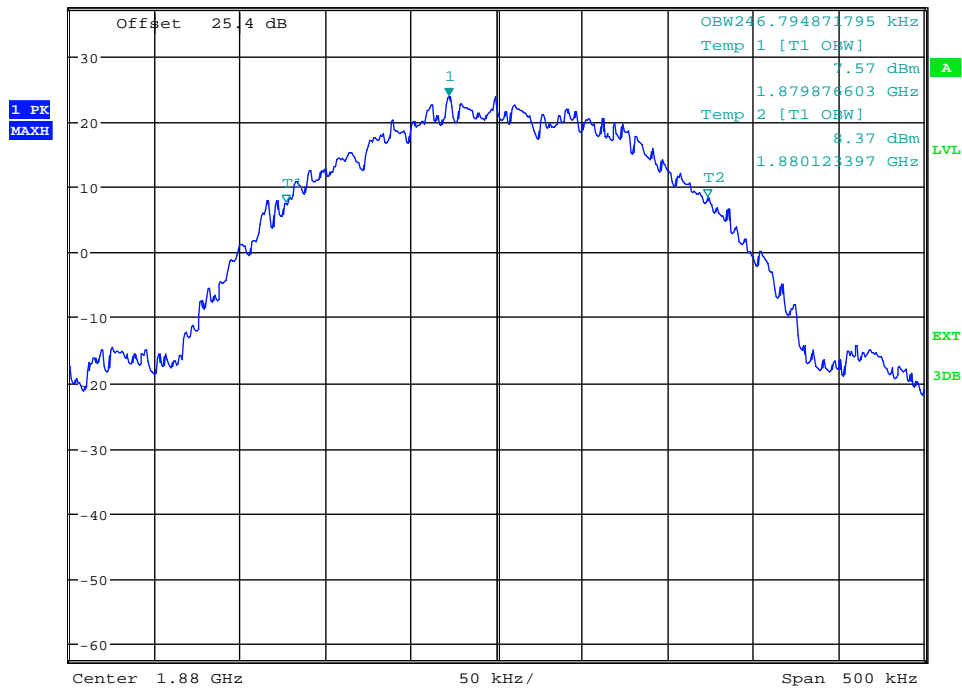

Date: 2.JAN.2014 16:42:37

(Plot 4.4.4 B: Channel 661:1880.00MHz @ EGPRS1900)



*RBW 5 kHz Marker 1 [T1]
*VBW 50 kHz 22.94 dBm
*SWT 20 ms 1.909815224 GHz

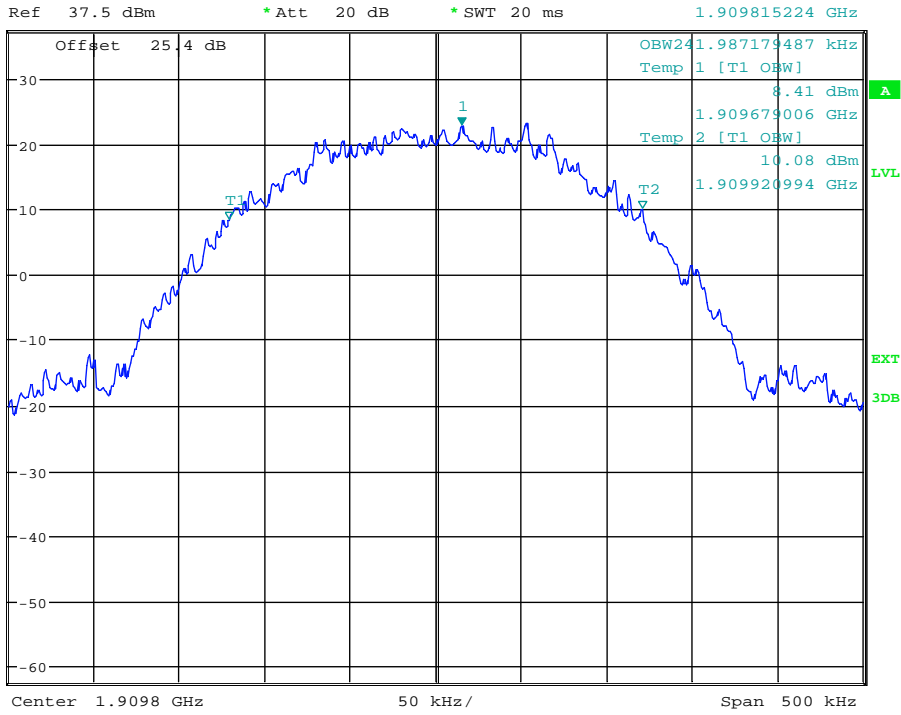

Date: 2.JAN.2014 16:42:14

(Plot 4.4.4 C: Channel 810:1909.80MHz @ EGPRS1900)

4.5. EMISSION BANDWIDTH

TEST APPLICABLE

Similar to conducted emissions; occupied bandwidth measurements are only provided for selected frequencies in order to reduce the amount of submitted data. Data were taken at the extreme and mid frequencies of PCS1900 band and GSM850 band. The table below lists the measured -26dBc BW.

TEST CONFIGURATION

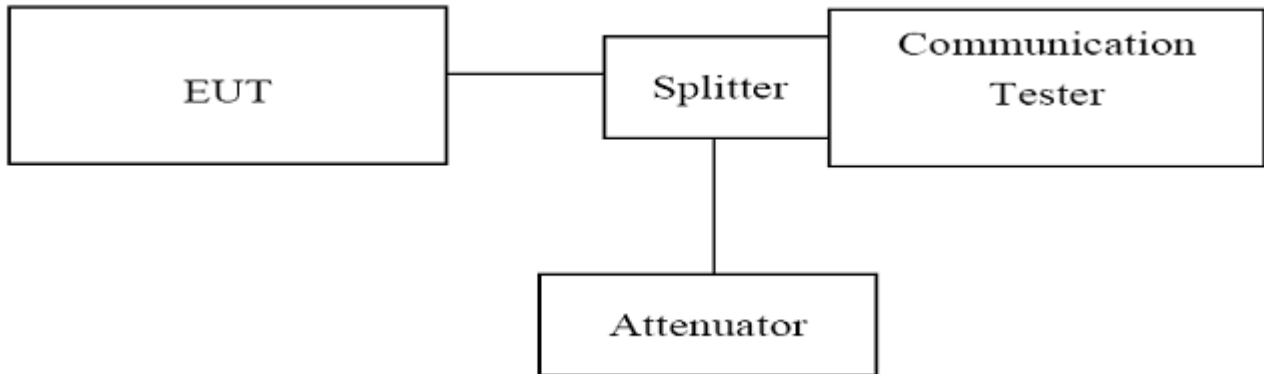

TEST PROCEDURE

1. The EUT was set up for the max output power with pseudo random data modulation;
2. The Occupied bandwidth was measured with Rhode & Schwarz Spectrum Analyzer FSU (peak);
3. Set RBW=5KHz,VBW=50KHz,Span=500KHz,SWT=20ms;
4. Set SPA Max hold. Mark peak, Set -26dBc Occupied Bandwidth
5. These measurements were done at 3 frequencies, 1850.20 MHz, 1880.00 MHz and 1909.80 MHz for PCS1900 band; 824.20MHz, 836.60 MHz and 848.80 MHz for GSM850 band. (bottom, middle and top of operational frequency range).

TEST RESULTS

GPRS850				
Channel Number	Frequency (MHz)	Occupied Bandwidth (-26dBc BW) (kHz)	Refer to Plot	Verdict
128	824.20	310.90	Plot 4.5.1 A	PASS
190	836.60	311.70	Plot 4.5.1 B	PASS
251	848.80	310.90	Plot 4.5.1 C	PASS

EGPRS850				
Channel Number	Frequency (MHz)	Occupied Bandwidth (-26dBc BW) (kHz)	Refer to Plot	Verdict
128	824.20	310.90	Plot 4.5.2 A	PASS
190	836.60	318.11	Plot 4.5.2 B	PASS
251	848.80	310.90	Plot 4.5.2 C	PASS



Ref 37.5 dBm * Att 20 dB * RBW 5 kHz * VBW 50 kHz * SWT 20 ms Marker 1 [T1] 25.36 dBm 824.216025641 MHz

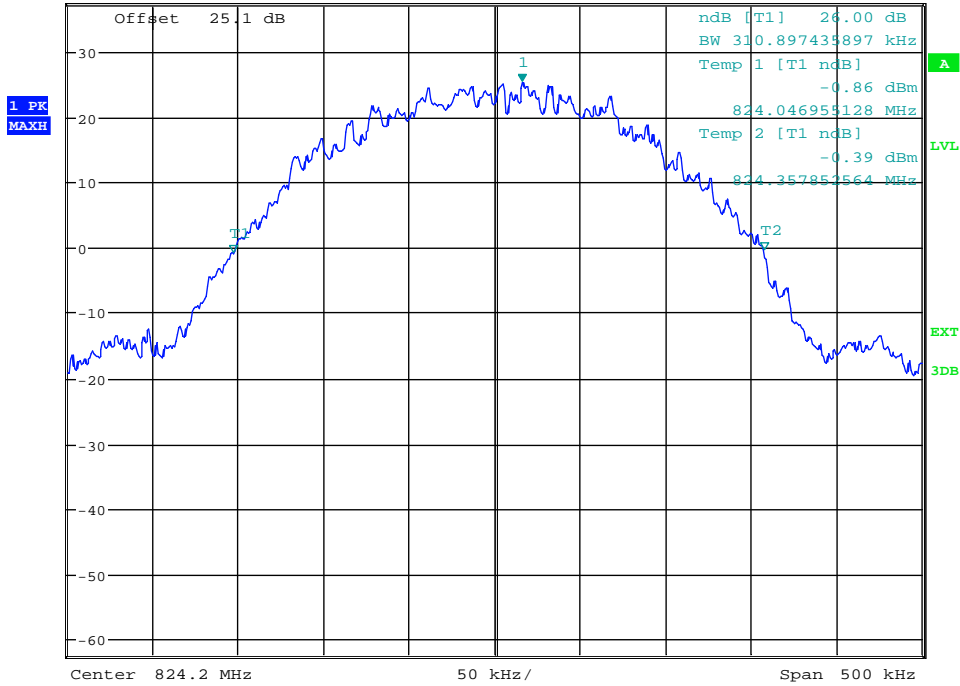

Date: 2.JAN.2014 15:44:03

(Plot 4.5.1 A: Channel 128: 824.20MHz @ GPRS850)



Ref 37.5 dBm * Att 20 dB * RBW 5 kHz * VBW 50 kHz * SWT 20 ms Marker 1 [T1] 26.83 dBm 836.606410256 MHz

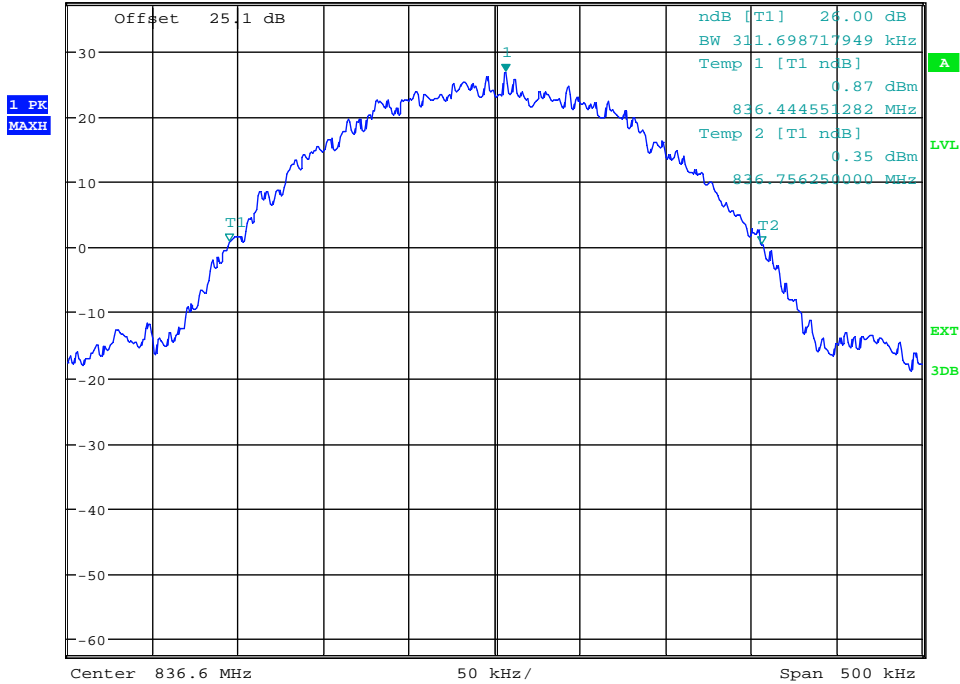

Date: 2.JAN.2014 15:44:45

(Plot 4.5.1 B: Channel 190: 836.60MHz @ GPRS850)



Ref 37.5 dBm * Att 20 dB * RBW 5 kHz * VBW 50 kHz * SWT 20 ms Marker 1 [T1] 27.05 dBm 848.806410256 MHz

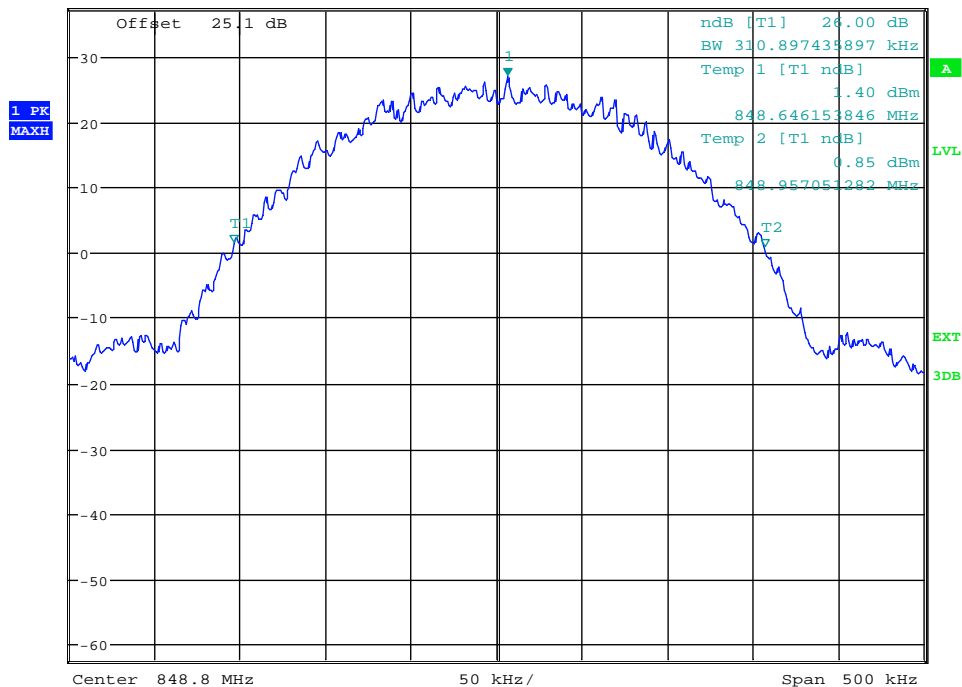

Date: 2.JAN.2014 15:45:18

(Plot 4.5.1 C: Channel 251: 848.80MHz @ GPRS850)



Ref 37.5 dBm * Att 20 dB * RBW 5 kHz * VBW 50 kHz * SWT 20 ms Marker 1 [T1] 25.70 dBm 824.175961538 MHz

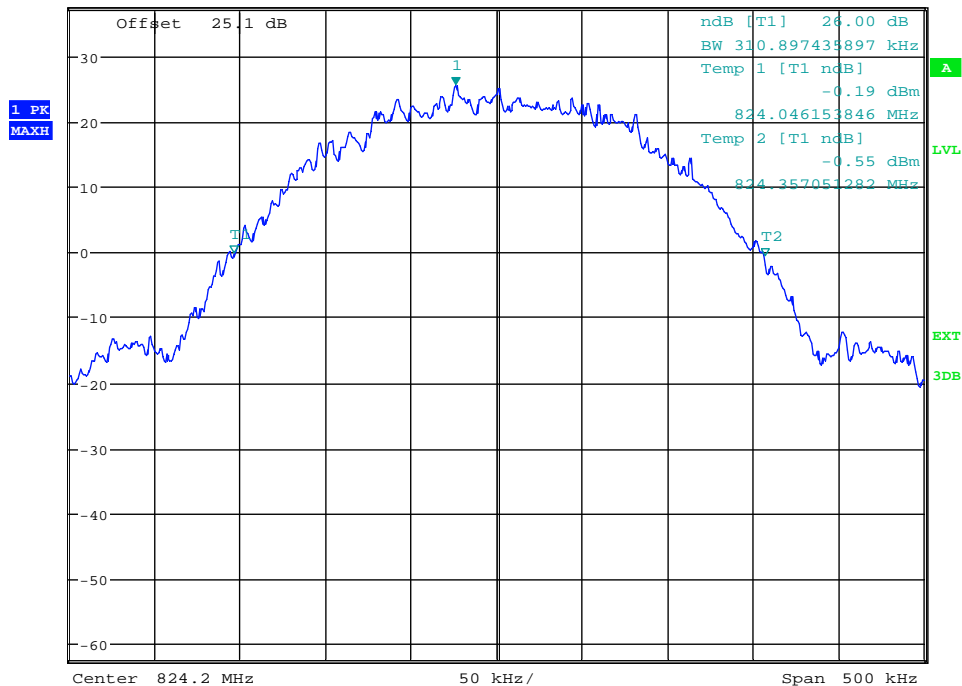

Date: 2.JAN.2014 16:02:37

(Plot 4.5.2 A: Channel 128: 824.20MHz @ EGPRS850)



*RBW 5 kHz Marker 1 [T1]
*VBW 50 kHz 25.55 dBm
*SWT 20 ms 836.580769231 MHz

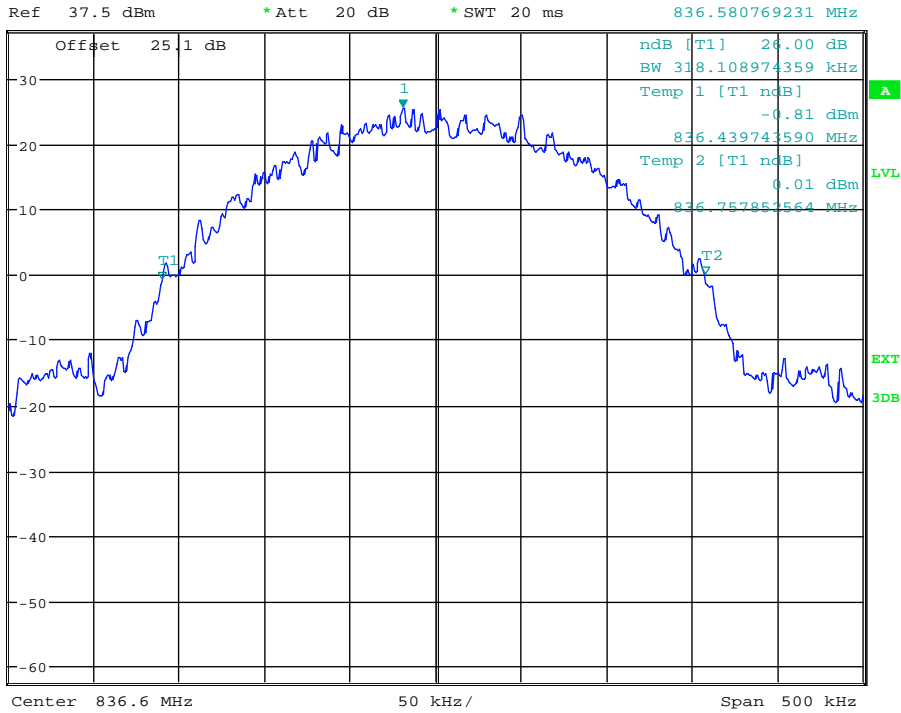

Date: 2.JAN.2014 16:03:01

(Plot 4.5.2 B: Channel 190: 836.60MHz @ EGPRS850)



*RBW 5 kHz Marker 1 [T1]
*VBW 50 kHz 26.32 dBm
*SWT 20 ms 848.773557692 MHz

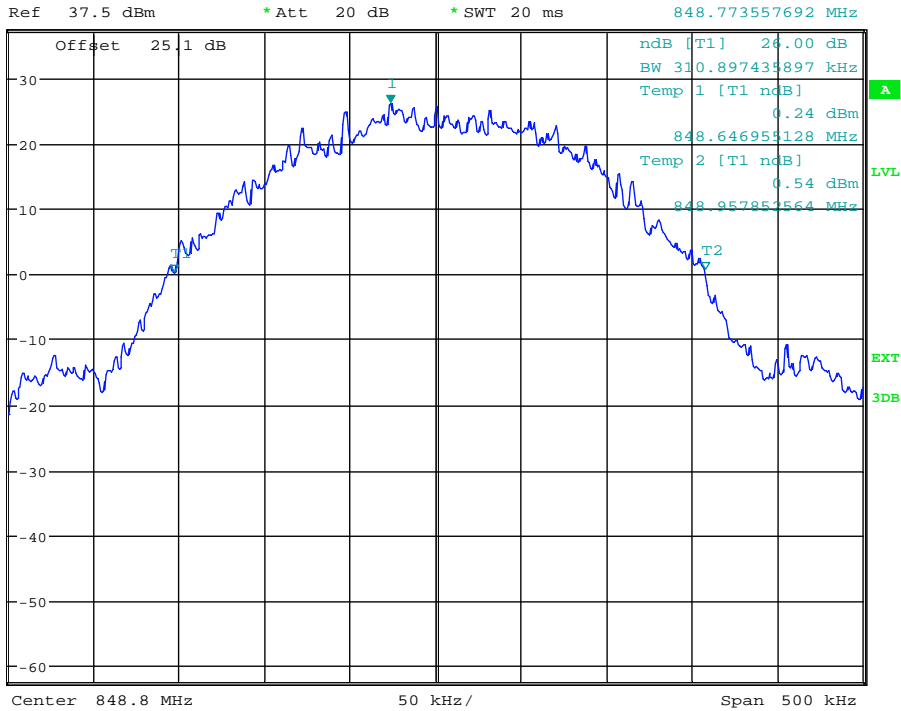

Date: 2.JAN.2014 16:03:29

(Plot 4.5.2 C: Channel 251: 848.80MHz @ EGPRS850)

GPRS1900				
Channel Number	Frequency (MHz)	Occupied Bandwidth (-26dBc BW) (kHz)	Refer to Plot	Verdict
512	1850.20	310.10	Plot 4.5.3 A	PASS
661	1880.00	314.90	Plot 4.5.3 B	PASS
810	1909.80	314.10	Plot 4.5.3 C	PASS

EGPRS1900				
Channel Number	Frequency (MHz)	Occupied Bandwidth (-26dBc BW) (kHz)	Refer to Plot	Verdict
512	1850.20	315.70	Plot 4.5.4 A	PASS
661	1880.00	315.71	Plot 4.5.4 B	PASS
810	1909.80	313.30	Plot 4.5.4 C	PASS

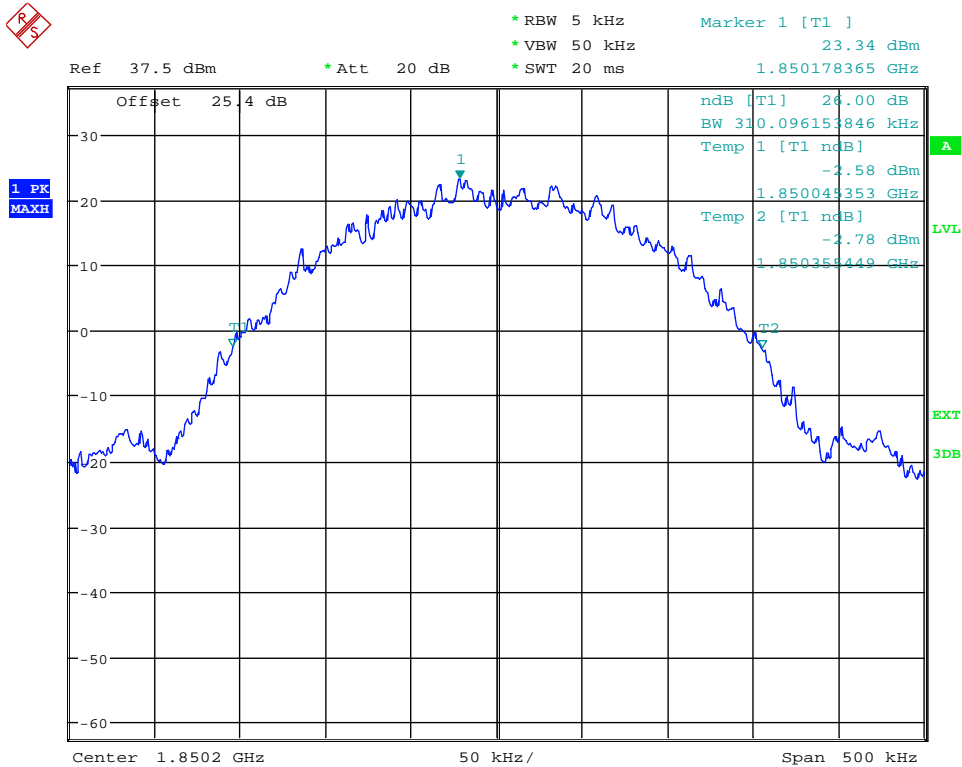

Date: 2.JAN.2014 16:15:58

(Plot 4.5.3 A: Channel 512:1850.20MHz @ GPRS1900)



Ref 37.5 dBm * Att 20 dB * RBW 5 kHz * VBW 50 kHz * SWT 20 ms Marker 1 [T1] 23.72 dBm 1.880016026 GHz

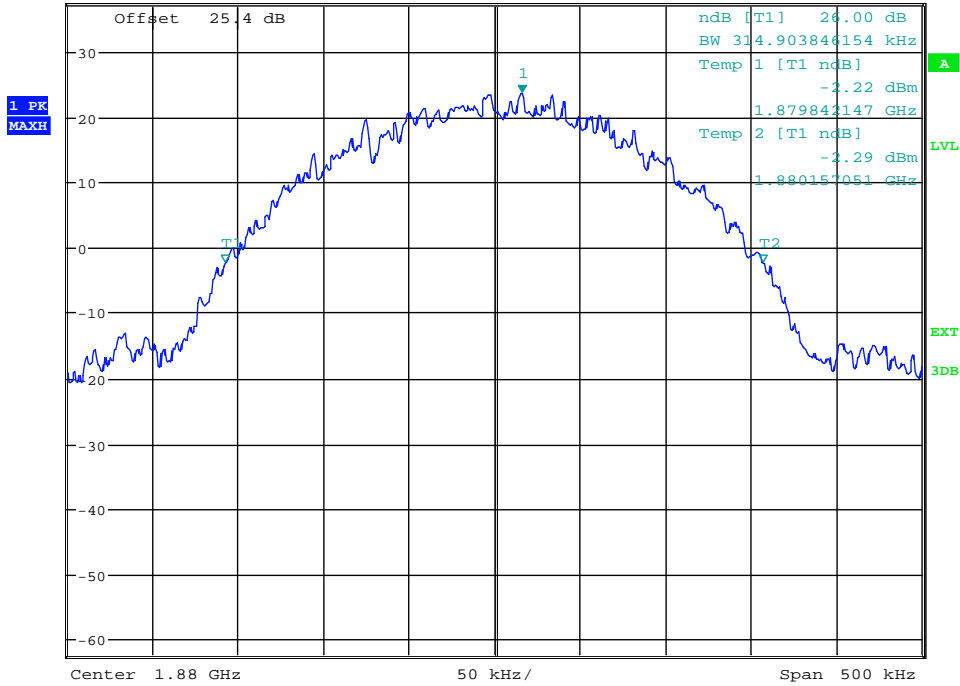

Date: 2.JAN.2014 16:16:40

(Plot 4.5.3 B: Channel 661:1880.00MHz @ GPRS1900)



Ref 37.5 dBm * Att 20 dB * RBW 5 kHz * VBW 50 kHz * SWT 20 ms Marker 1 [T1] 23.90 dBm 1.909794391 GHz

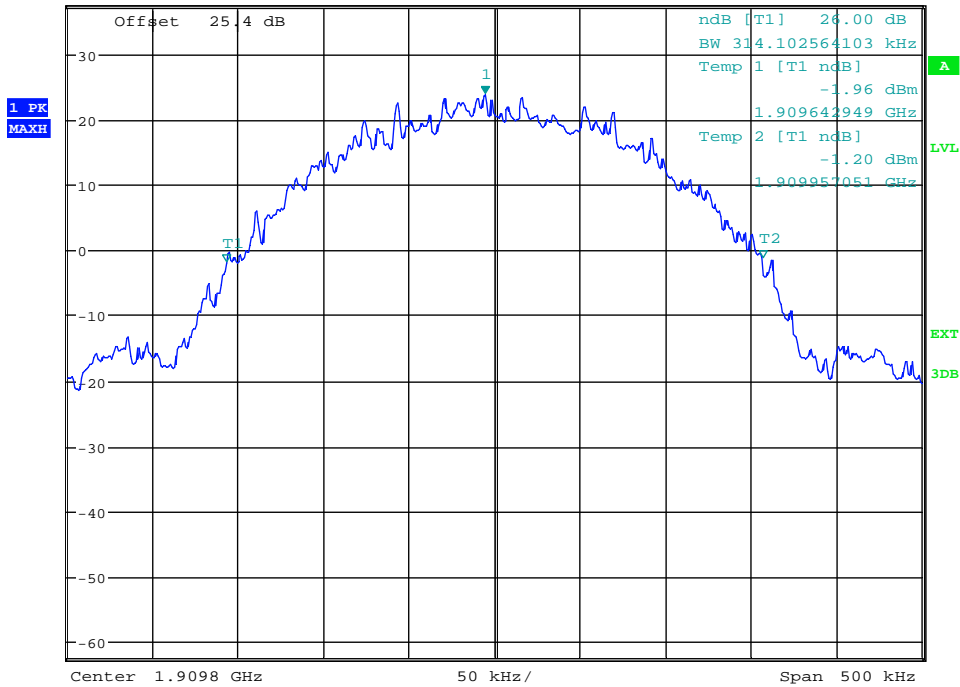

Date: 2.JAN.2014 16:17:06

(Plot 4.5.3 C: Channel 810:1909.80MHz @ GPRS1900)



Ref 37.5 dBm * Att 20 dB * RBW 5 kHz * VBW 50 kHz * SWT 20 ms Marker 1 [T1] 23.18 dBm 1.850180769 GHz

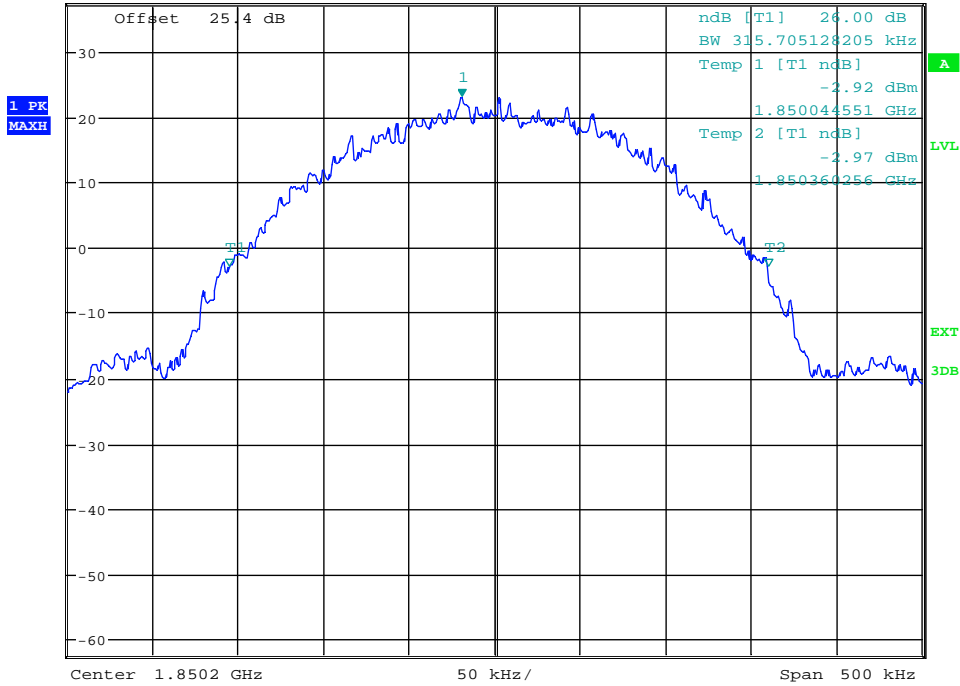

Date: 2.JAN.2014 16:43:18

(Plot 4.5.4 A: Channel 512:1850.20MHz @ EGPRS1900)



Ref 37.5 dBm * Att 20 dB * RBW 5 kHz * VBW 50 kHz * SWT 20 ms Marker 1 [T1] 23.63 dBm 1.879966346 GHz

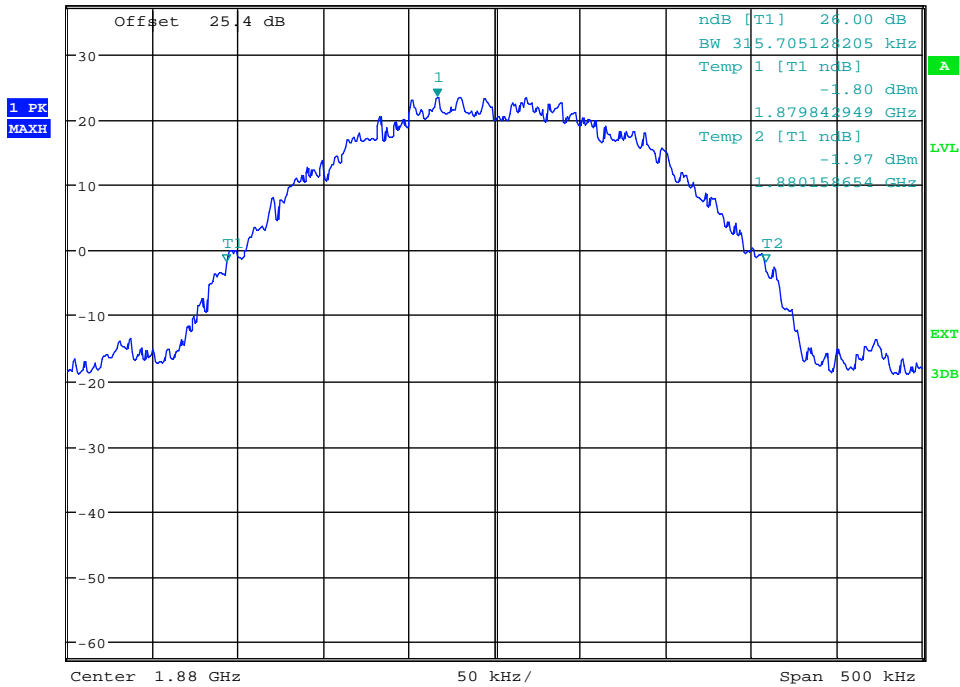

Date: 2.JAN.2014 16:43:44

(Plot 4.5.4 B: Channel 661:1880.00MHz @ EGPRS1900)



*RBW 5 kHz Marker 1 [T1]
*VBW 50 kHz 25.19 dBm
*SWT 20 ms 1.909794391 GHz

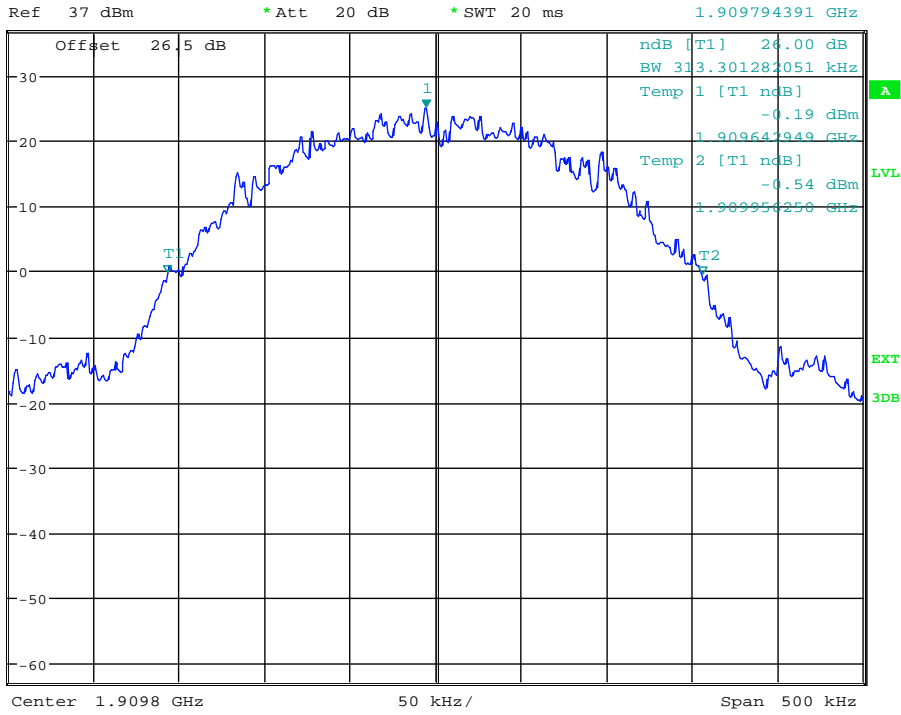

Date: 10.DEC.2013 14:39:13

(Plot 4.5.4 C: Channel 810:1909.80MHz @ EGPRS1900)

4.6. BAND EDGE COMPLIANCE

TEST APPLICABLE

During the process of testing, the EUT was controlled via Rhode & Schwarz Digital Radio Communication tester (CMU-200) to ensure max power transmission and proper modulation.

TEST CONFIGURATION

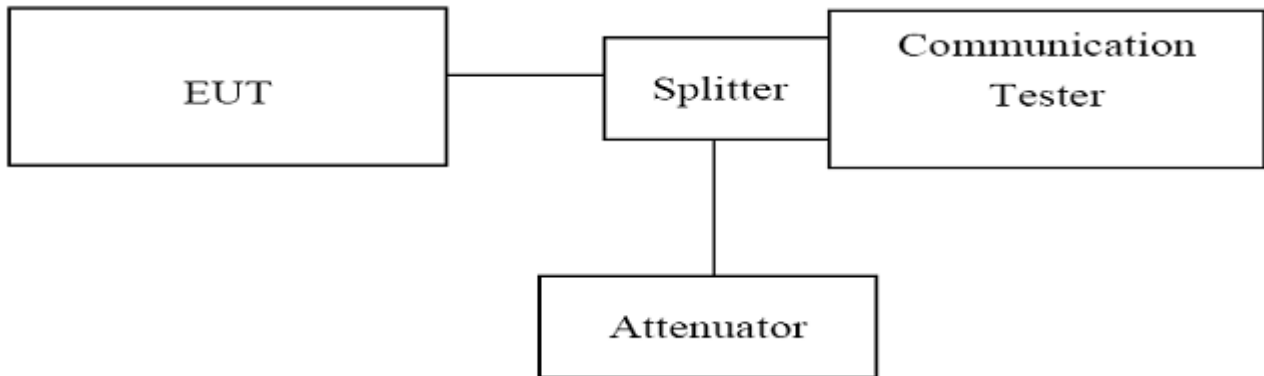

TEST PROCEDURE

1. The EUT was set up for the max output power with pseudo random data modulation;
2. The power was measured with Rhode & Schwarz Spectrum Analyzer FSU (peak);
3. Set RBW=5KHz,VBW=50KHz,Span=1MHz,SWT=300ms;
4. These measurements were done at 3 frequencies, 1850.20 MHz, 1880.00 MHz and 1909.80 MHz for PCS1900 band; 824.20 MHz, 836.60 MHz and 848.80 MHz for GSM850 band. (low, middle and high of operational frequency range).

TEST RESULTS

GPRS850						
Channel Number	Frequency (MHz)	Measurement Results		Limit (dBm)	Refer to Plot	Verdict
		Frequency (MHz)	Values (dBm)			
128	824.20	824.00	-13.85	-13.00	Plot 4.6.1 A	PASS
251	848.80	849.00	-13.09	-13.00	Plot 4.6.1 B	PASS

EGPRS850						
Channel Number	Frequency (MHz)	Measurement Results		Limit (dBm)	Refer to Plot	Verdict
		Frequency (MHz)	Values (dBm)			
128	824.20	823.98	-14.39	-13.00	Plot 4.6.2 A	PASS
251	848.80	849.02	-13.26	-13.00	Plot 4.6.2 B	PASS



*RBW 5 kHz Marker 1 [T1]
*VBW 50 kHz -13.85 dBm
*SWT 300 ms 823.995192308 MHz

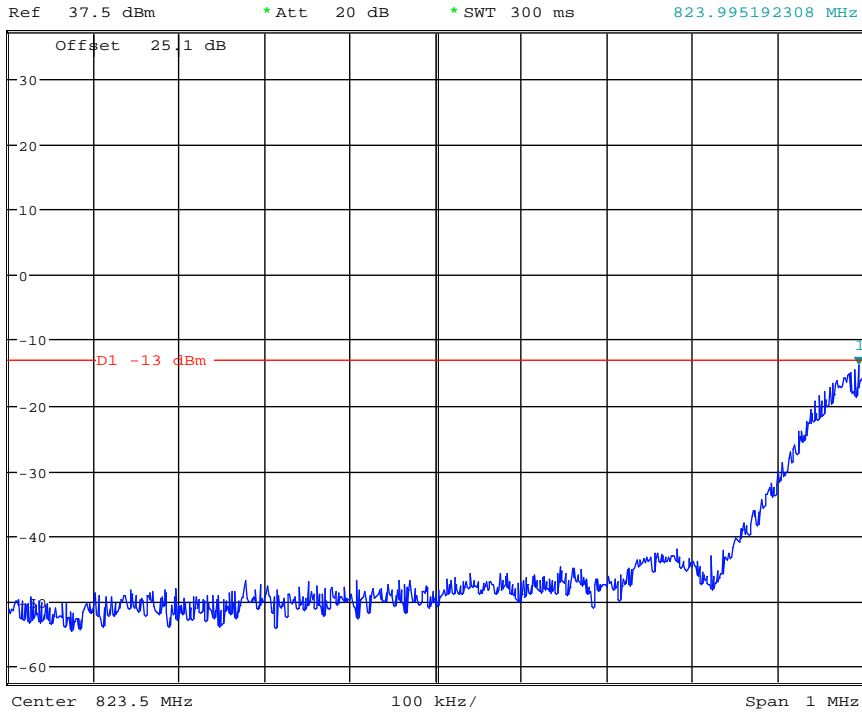

Date: 2.JAN.2014 15:47:59

(Plot 4.6.1 A: Channel 128: 824.20MHz @ GPRS850)



*RBW 5 kHz Marker 1 [T1]
*VBW 50 kHz -13.09 dBm
*SWT 300 ms 849.001602564 MHz

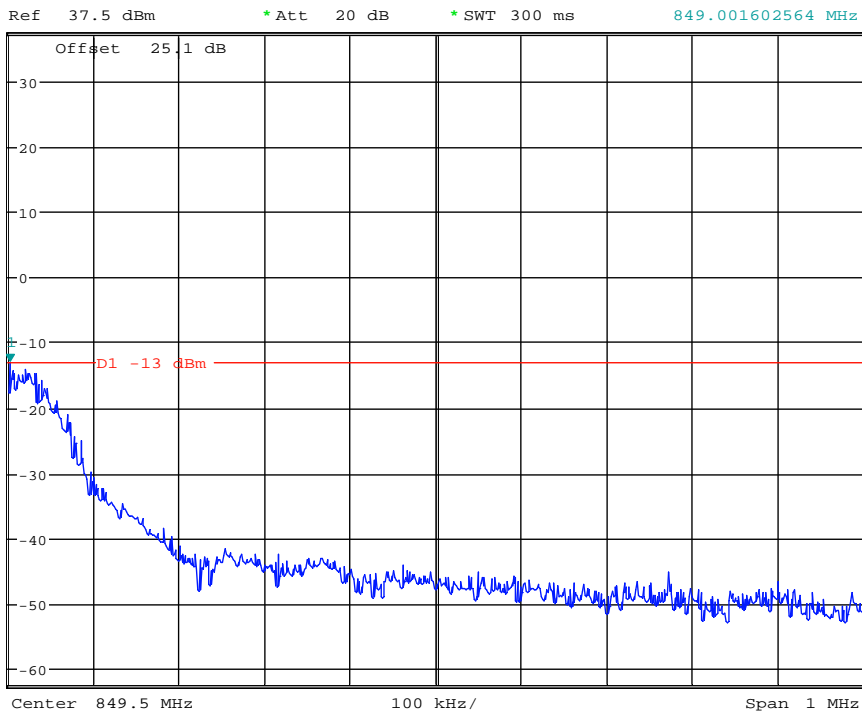

Date: 2.JAN.2014 15:46:42

(Plot 4.6.1 B: Channel 251: 848.80MHz @ GPRS850)



Ref 37.5 dBm * Att 20 dB * RBW 5 kHz * VBW 50 kHz * SWT 300 ms Marker 1 [T1] -14.39 dBm 823.975961538 MHz

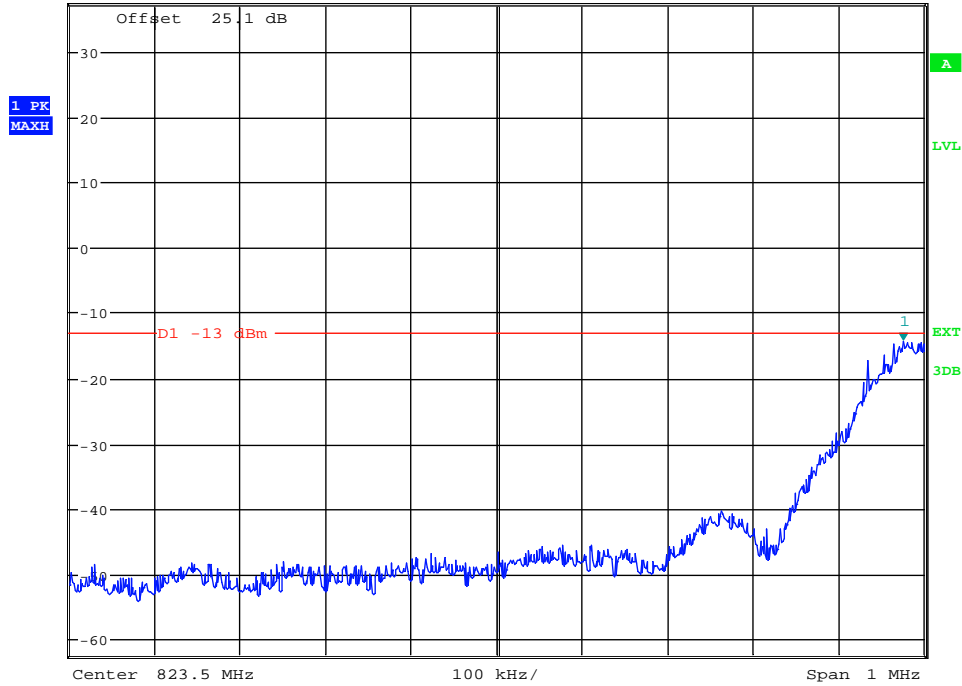

Date: 2.JAN.2014 16:05:50

(Plot 4.6.2 A: Channel 128: 824.20MHz @ EGPRS850)



Ref 37.5 dBm * Att 20 dB * RBW 5 kHz * VBW 50 kHz * SWT 300 ms Marker 1 [T1] -13.26 dBm 849.022435897 MHz

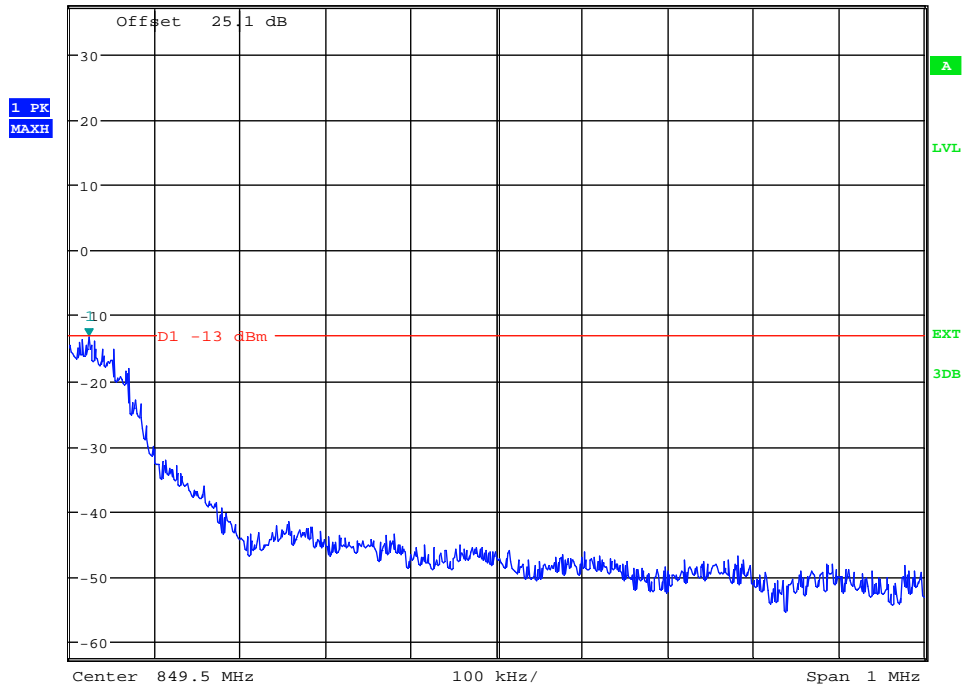

Date: 2.JAN.2014 16:05:02

(Plot 4.6.2 B: Channel 251: 848.80MHz @ EGPRS850)

GPRS1900						
Channel Number	Frequency (MHz)	Measurement Results		Limit (dBm)	Refer to Plot	Verdict
		Frequency (MHz)	Values (dBm)			
512	1850.20	1850.00	-14.82	-13.00	Plot 4.6.3 A	PASS
810	1909.80	1910.02	-14.12	-13.00	Plot 4.6.3 B	PASS

EGPRS1900						
Channel Number	Frequency (MHz)	Measurement Results		Limit (dBm)	Refer to Plot	Verdict
		Frequency (MHz)	Values (dBm)			
512	1850.20	1850.00	-14.42	-13.00	Plot 4.6.4 A	PASS
810	1909.80	1910.03	-13.20	-13.00	Plot 4.6.4 B	PASS

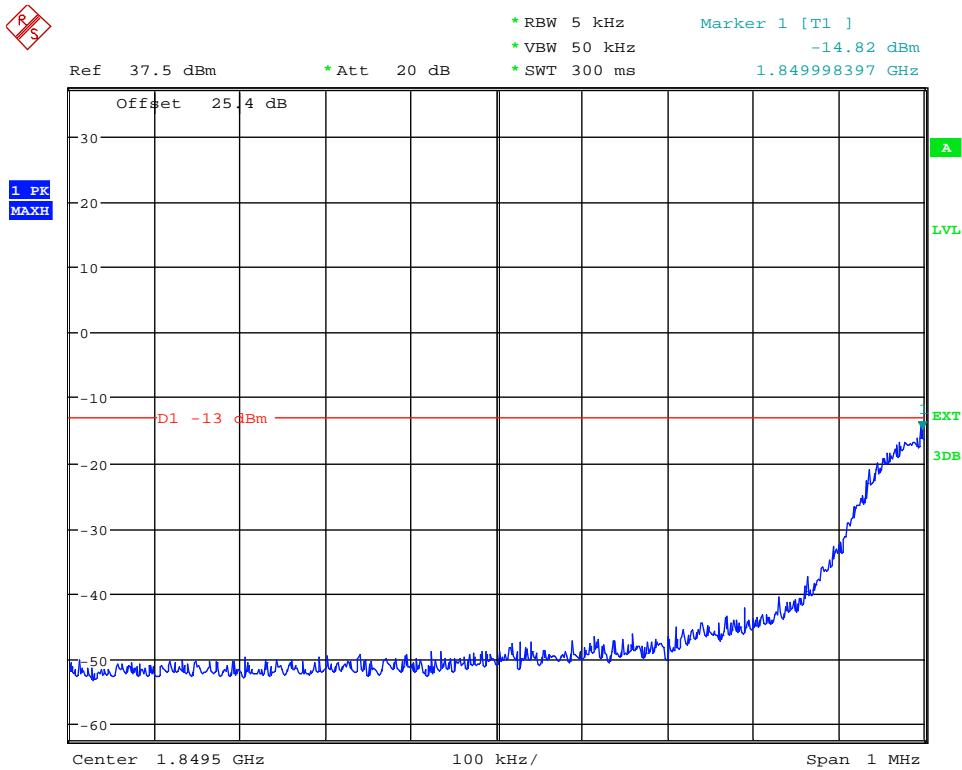

Date: 2.JAN.2014 16:21:05

(Plot 4.6.3 A: Channel 512: 1850.20MHz @ GPRS1900)



*RBW 5 kHz Marker 1 [T1]
*VBW 50 kHz -14.12 dBm
*SWT 300 ms 1.910020833 GHz

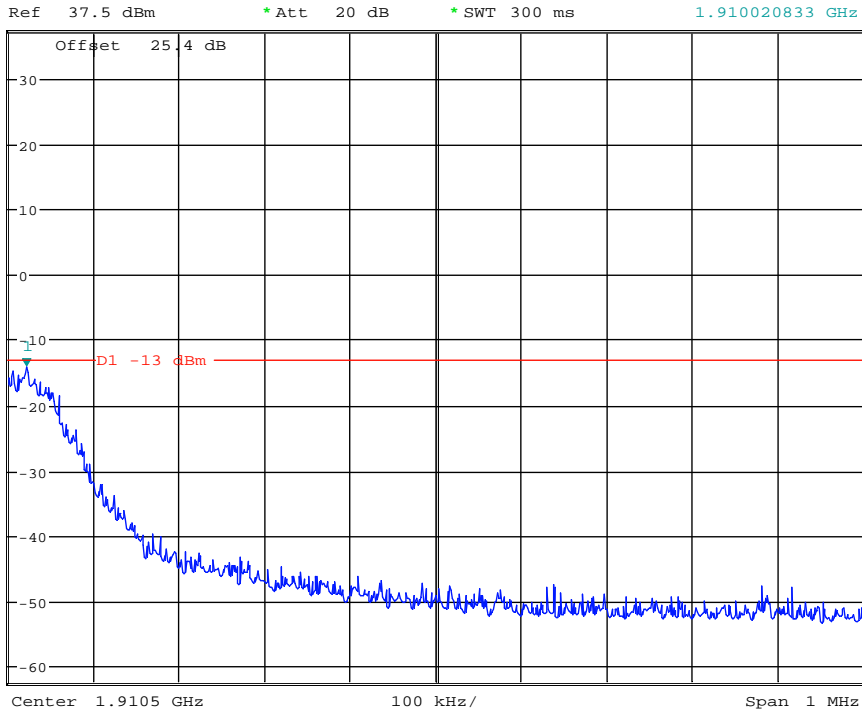

Date: 2.JAN.2014 16:19:08

(Plot 4.6.3 B: Channel 810: 1909.80MHz @ GPRS1900)



*RBW 5 kHz Marker 1 [T1]
*VBW 50 kHz -14.42 dBm
*SWT 300 ms 1.849998397 GHz

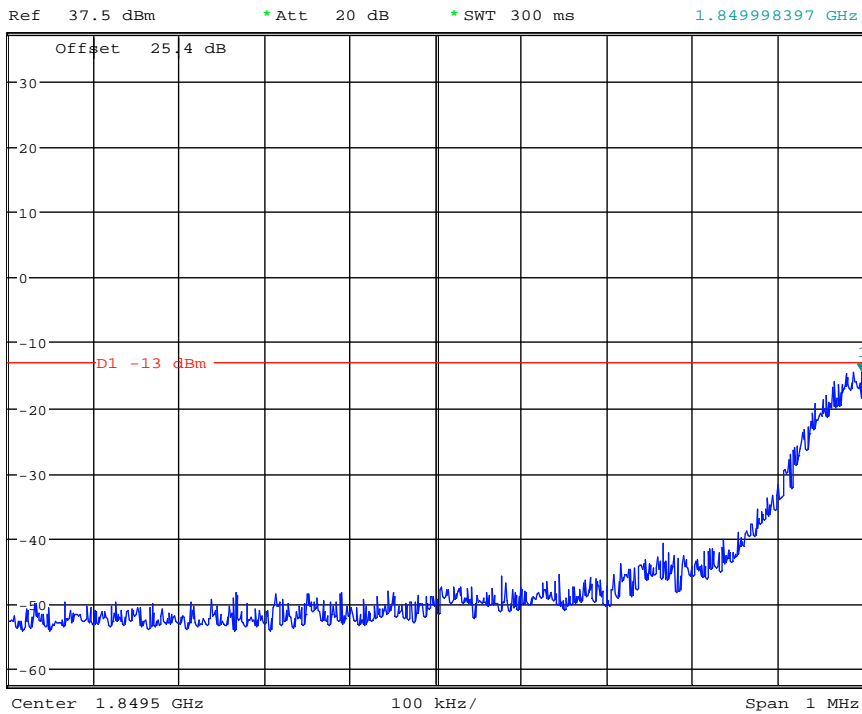

Date: 2.JAN.2014 16:46:07

(Plot 4.6.4 A: Channel 512: 1850.20MHz @ EGPRS1900)



*RBW 5 kHz Marker 1 [T1]
*VBW 50 kHz -13.20 dBm
*SWT 300 ms 1.910025641 GHz

Ref 37.5 dBm *Att 20 dB

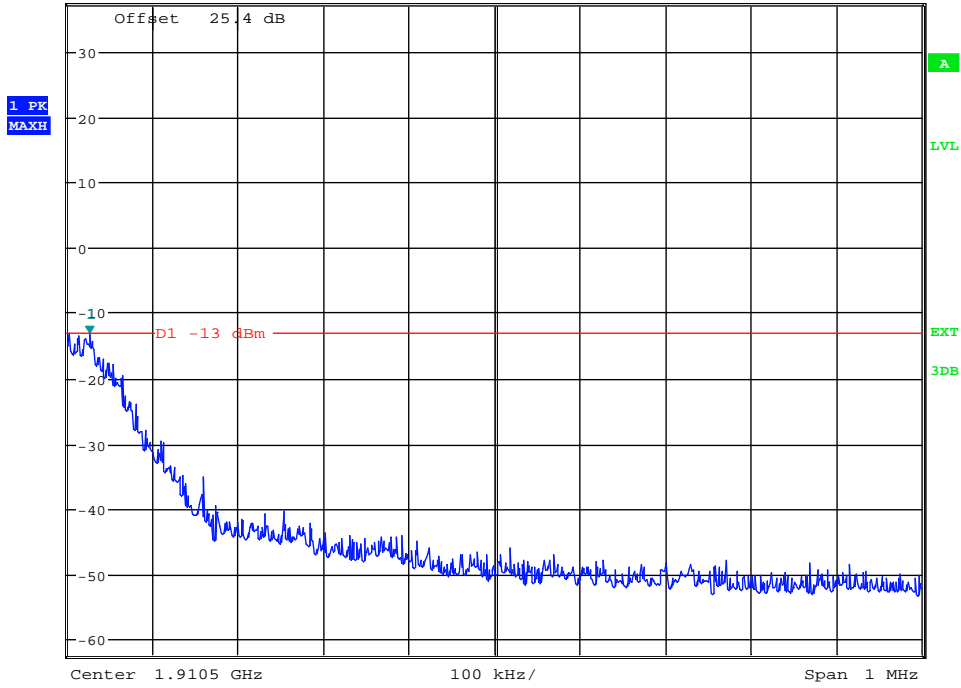

Date: 2.JAN.2014 16:45:26

(Plot 4.6.4 B: Channel 810: 1909.80MHz @ EGPRS1900)

4.7. Spurious Emission on Antenna Port

TEST APPLICABLE

The following steps outline the procedure used to measure the conducted emissions from the EUT.

1. Determine frequency range for measurements: From CFR 2.1057 the spectrum should be investigated from the lowest radio frequency generated in the equipment up to at least the 10th harmonic of the carrier frequency. For the equipment of PCS1900 band, this equates to a frequency range of 30 MHz to 19.1 GHz, data taken from 30 MHz to 20 GHz. For GSM850, data taken from 30 MHz to 10 GHz.
2. The sweep time is set automatically by instrument itself. That should be the optimal sweep time for the span and the RBW. If the sweep time is too short, that is sweep is too fast, the sweep result is not accurate; if the sweep time is too long, that is sweep is too low, some frequency components may be lost. The instrument will give a optimal sweep time according the selected span and RBW.
3. The procedure to get the conducted spurious emission is as follows:
The trace mode is set to MaxHold to get the highest signal at each frequency;
Wait 25 seconds;
Get the result.
4. Determine EUT transmit frequencies: below outlines the band edge frequencies pertinent to conducted emissions testing.

TEST CONFIGURATION

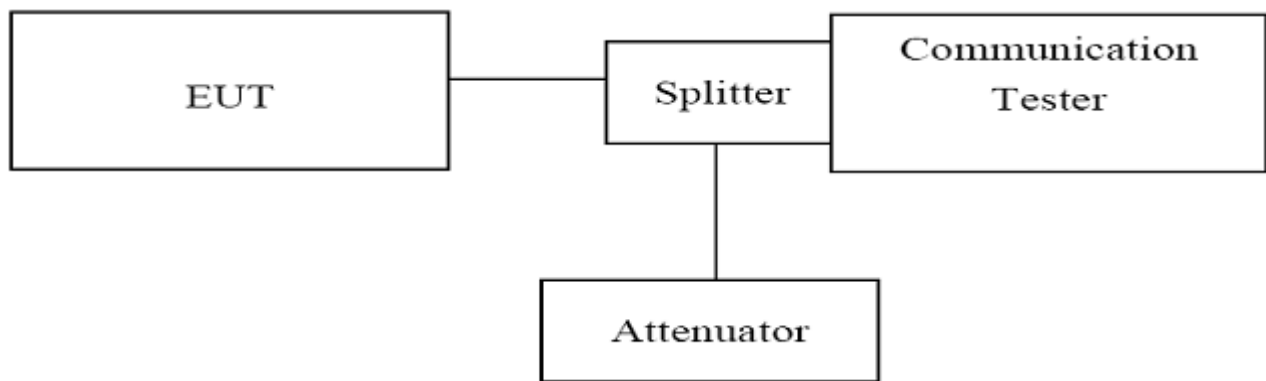

TEST PROCEDURE

1. The EUT was set up for the max output power with pseudo random data modulation;
2. The power was measured with Rhode & Schwarz Spectrum Analyzer FSU (peak);
3. These measurements were done at 3 frequencies, 1850.20 MHz, 1880.00 MHz and 1909.80 MHz for PCS1900 band; 824.20 MHz, 836.60 MHz and 848.80 MHz for GSM850 band. (low, middle and high of operational frequency range).

TEST LIMIT

Part 24.238 and Part 22.917 specify that the power of any emission outside of the authorized operating frequency ranges must be attenuated below the transmitting power (P) by a factor of at least $43 + 10 \log(P)$ dB.

The specification that emissions shall be attenuated below the transmitter power (P) by at least $43 + 10 \log(P)$ dB, translates in the relevant power range (1 to 0.001 W) to -13 dBm. At 1 W the specified minimum attenuation becomes 43 dB and relative to a 30 dBm (1 W) carrier becomes a limit of -13 dBm. At 0.001 W (0 dBm) the minimum attenuation is 13 dB, which again yields a limit of -13 dBm. In this way a translation of the specification from relative to absolute terms is carried out.

TEST RESULTS

GPRS850						
Channel Number: 128		Test Frequency: 824.20 MHz			Test Mode: Traffic	
Start Frequency (MHz)	Stop Frequency (MHz)	Measurement Results		Limit (dBm)	Refer to Plot	Verdict
		Frequency (MHz)	Values (dBm)			
30	1000	***	***	-13.00	Plot 4.7.1 A1	PASS
1000	2500	2497.60	-31.70	-13.00	Plot 4.7.1 A2	PASS
2500	7500	3493.59	-31.79	-13.00	Plot 4.7.1 A3	PASS
7500	10000	8165.06	-33.02	-13.00	Plot 4.7.1 A4	PASS

GPRS850						
Channel Number: 190		Test Frequency: 836.60 MHz			Test Mode: Traffic	
Start Frequency (MHz)	Stop Frequency (MHz)	Measurement Results		Limit (dBm)	Refer to Plot	Verdict
		Frequency (MHz)	Values (dBm)			
30	1000	***	***	-13.00	Plot 4.7.2 A1	PASS
1000	2500	1673.08	-29.26	-13.00	Plot 4.7.2 A2	PASS
2500	7500	2508.01	-31.21	-13.00	Plot 4.7.2 A3	PASS
7500	10000	9354.97	-32.68	-13.00	Plot 4.7.2 A4	PASS

GPRS850						
Channel Number: 251		Test Frequency: 848.80 MHz			Test Mode: Traffic	
Start Frequency (MHz)	Stop Frequency (MHz)	Measurement Results		Limit (dBm)	Refer to Plot	Verdict
		Frequency (MHz)	Values (dBm)			
30	1000	***	***	-13.00	Plot 4.7.3 A1	PASS
1000	2500	1697.12	-27.84	-13.00	Plot 4.7.3 A2	PASS
2500	7500	3485.58	-30.49	-13.00	Plot 4.7.3 A3	PASS
7500	10000	7879.81	-33.07	-13.00	Plot 4.7.3 A4	PASS

GPRS850						
Test Mode: Idle						
Start Frequency (MHz)	Stop Frequency (MHz)	Measurement Results		Limit (dBm)	Refer to Plot	Verdict
		Frequency (MHz)	Values (dBm)			
30	1000	626.92	-34.39	-13.00	Plot 4.7.4 A1	PASS
1000	2500	2471.15	-32.92	-13.00	Plot 4.7.4 A2	PASS
2500	7500	2532.05	-31.72	-13.00	Plot 4.7.4 A3	PASS
7500	10000	7644.23	-33.31	-13.00	Plot 4.7.4 A4	PASS

Note: 1. In general, the worse case attenuation requirement shown above was applied.

2. *** means that the emission level is too low to be measured or at least 20 dB down than the limit.



Ref 37.5 dBm * Att 20 dB * RBW 1 MHz Marker 1 [T1]
* VBW 3 MHz 31.46 dBm
SWT 2.5 ms 825.897435897 MHz

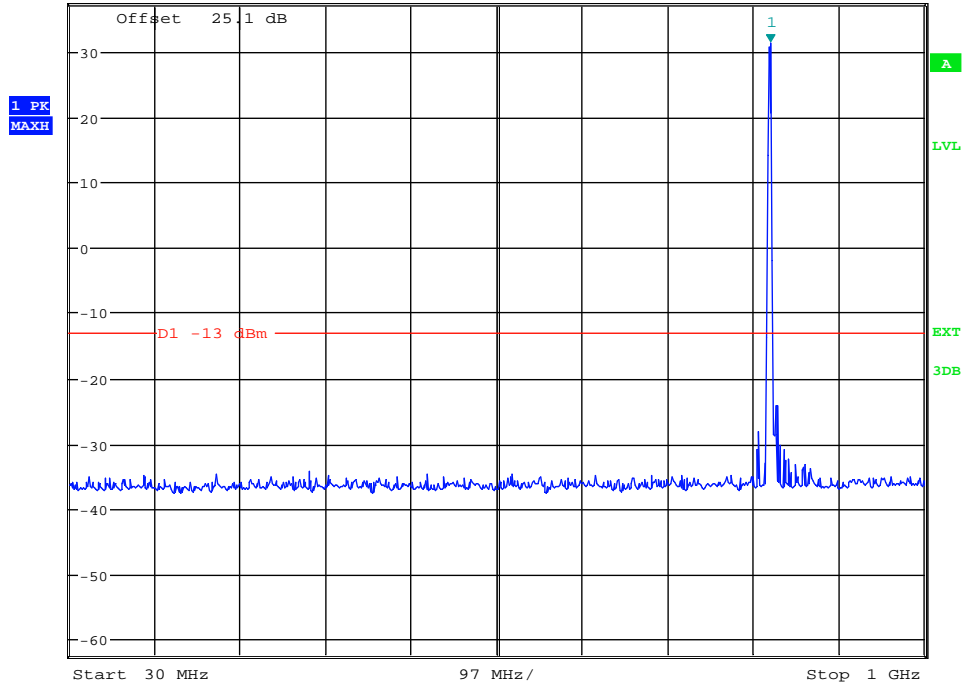

Date: 2.JAN.2014 15:48:48

(Plot 4.7.1 A1: Channel 128: 824.20MHz @ Traffic @ GSM850)



Ref 37.5 dBm * Att 20 dB * RBW 1 MHz Marker 1 [T1]
* VBW 3 MHz -31.70 dBm
SWT 5 ms 2.497596154 GHz

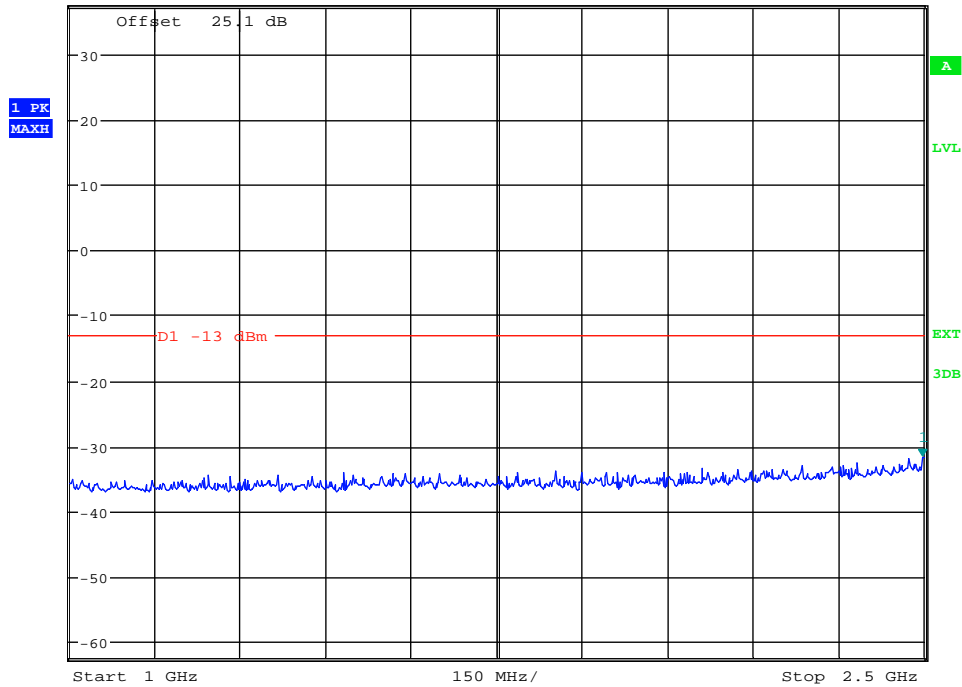

Date: 2.JAN.2014 15:49:21

(Plot 4.7.1 A2: Channel 128: 824.20MHz @ Traffic @ GSM850)



*RBW 1 MHz Marker 1 [T1]
*VBW 3 MHz -31.79 dBm
SWT 30 ms 3.493589744 GHz

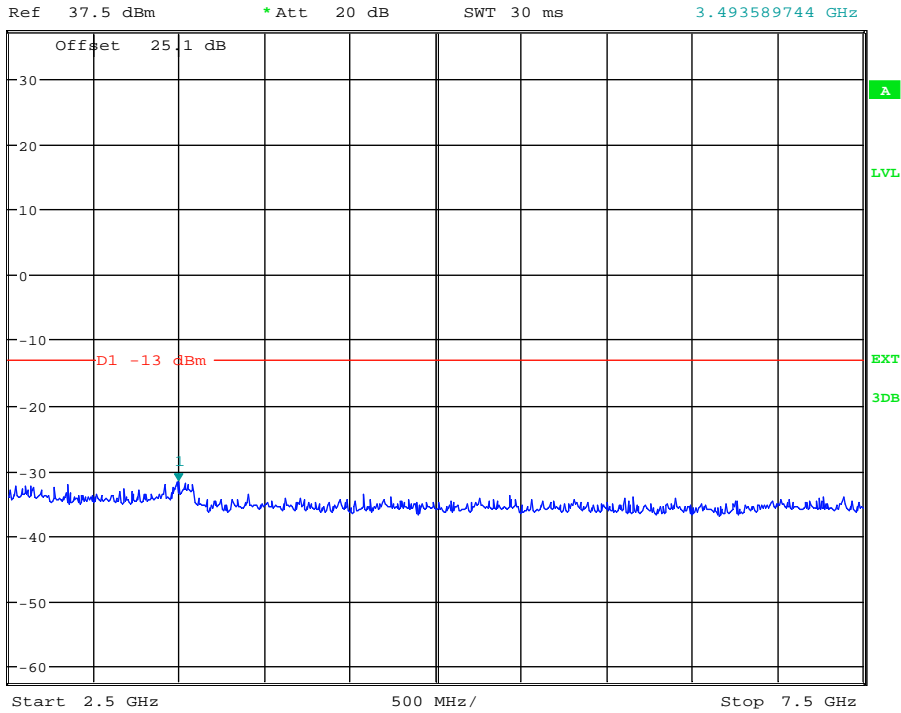

Date: 2.JAN.2014 15:49:37

(Plot 4.7.1 A3: Channel 128: 824.20MHz @ Traffic @ GSM850)



*RBW 1 MHz Marker 1 [T1]
*VBW 3 MHz -33.02 dBm
SWT 20 ms 8.165064103 GHz

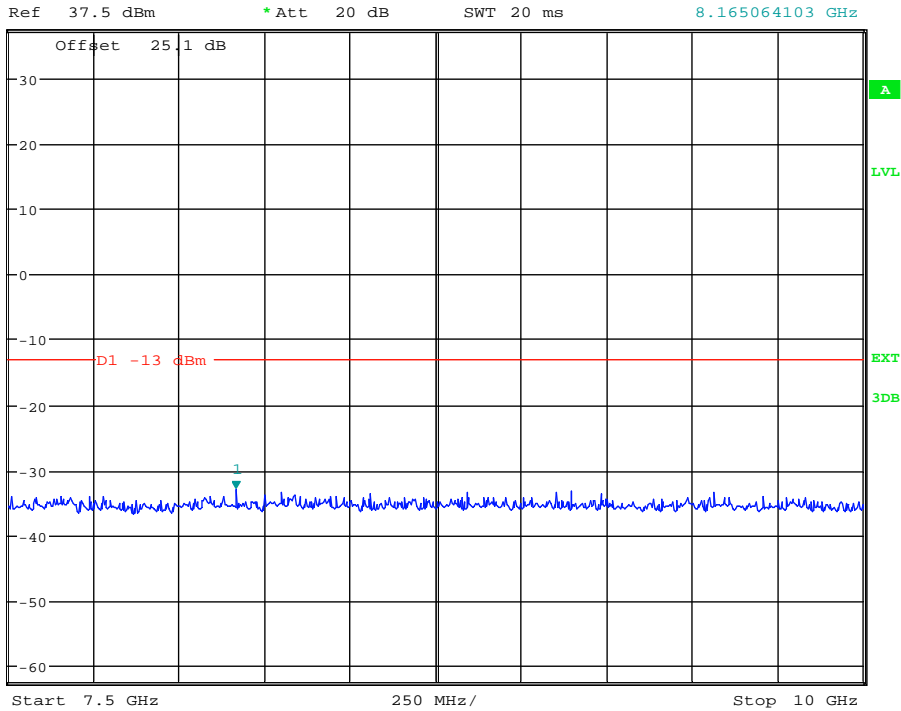

Date: 2.JAN.2014 15:49:53

(Plot 4.7.1 A4: Channel 128: 824.20MHz @ Traffic @ GSM850)



Ref 37.5 dBm * Att 20 dB * RBW 1 MHz Marker 1 [T1] 31.86 dBm
* VBW 3 MHz 836.778846154 MHz
SWT 2.5 ms

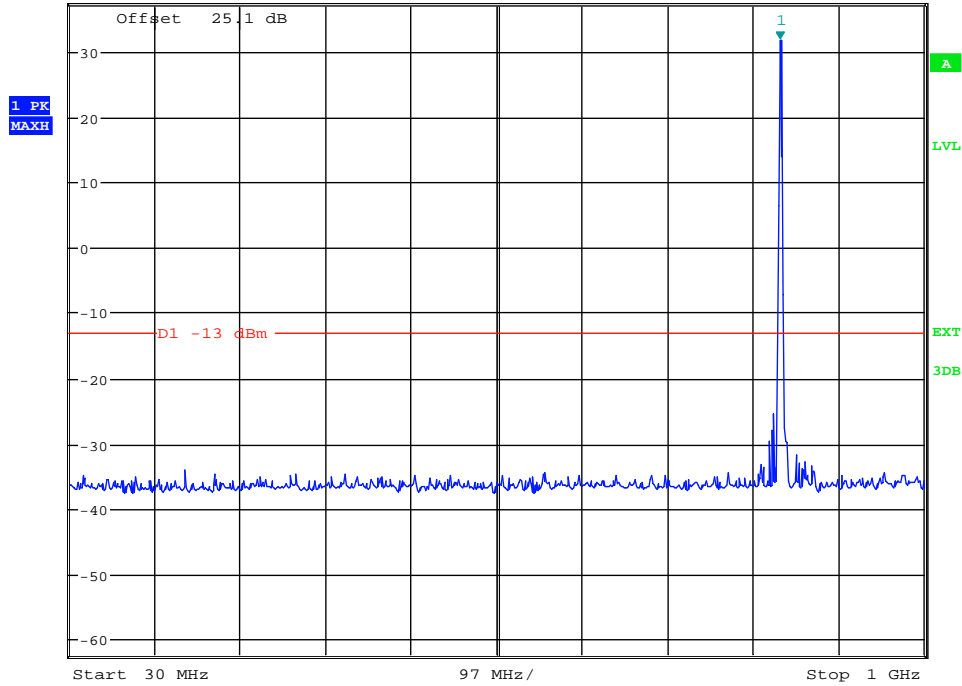

Date: 2.JAN.2014 15:50:19

(Plot 4.7.2 A1: Channel 190: 836.60MHz @ Traffic @ GSM850)



Ref 37.5 dBm * Att 20 dB * RBW 1 MHz Marker 1 [T1] -29.26 dBm
* VBW 3 MHz 1.673076923 GHz
SWT 5 ms

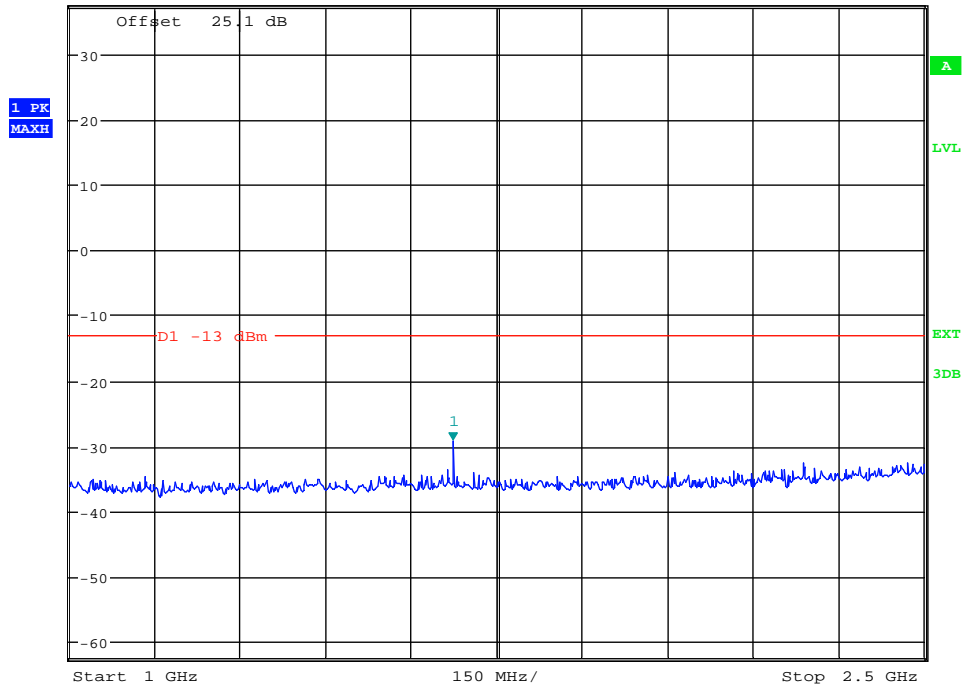

Date: 2.JAN.2014 15:50:33

(Plot 4.7.2 A2: Channel 190: 836.60MHz @ Traffic @ GSM850)



*RBW 1 MHz Marker 1 [T1]
*VBW 3 MHz -31.21 dBm
SWT 30 ms 2.508012821 GHz

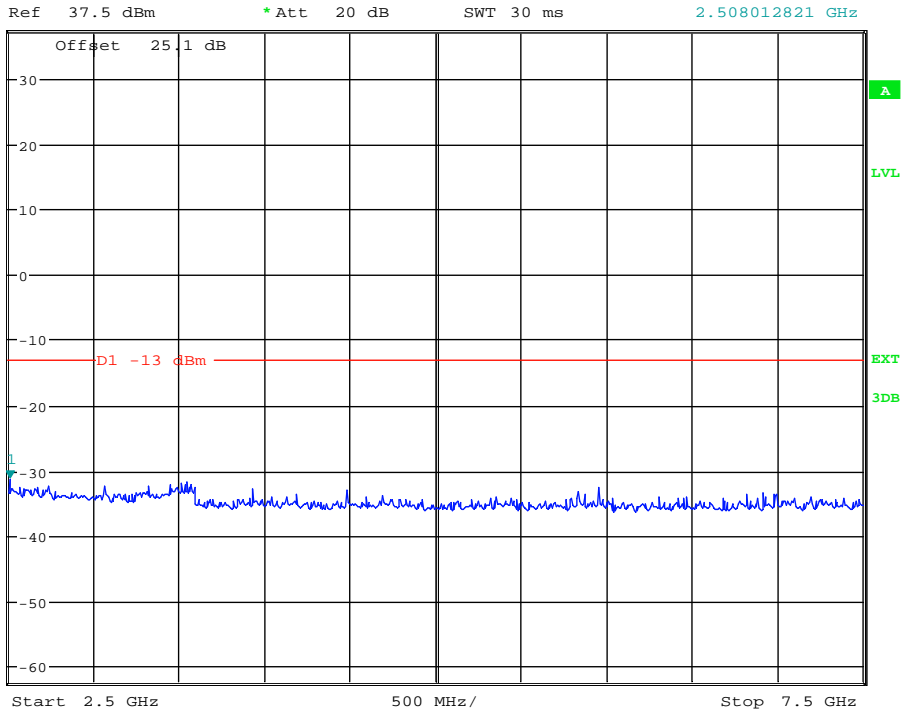

Date: 2.JAN.2014 15:51:03

(Plot 4.7.2 A3: Channel 190: 836.60MHz @ Traffic @ GSM850)



*RBW 1 MHz Marker 1 [T1]
*VBW 3 MHz -32.68 dBm
SWT 20 ms 9.354967949 GHz

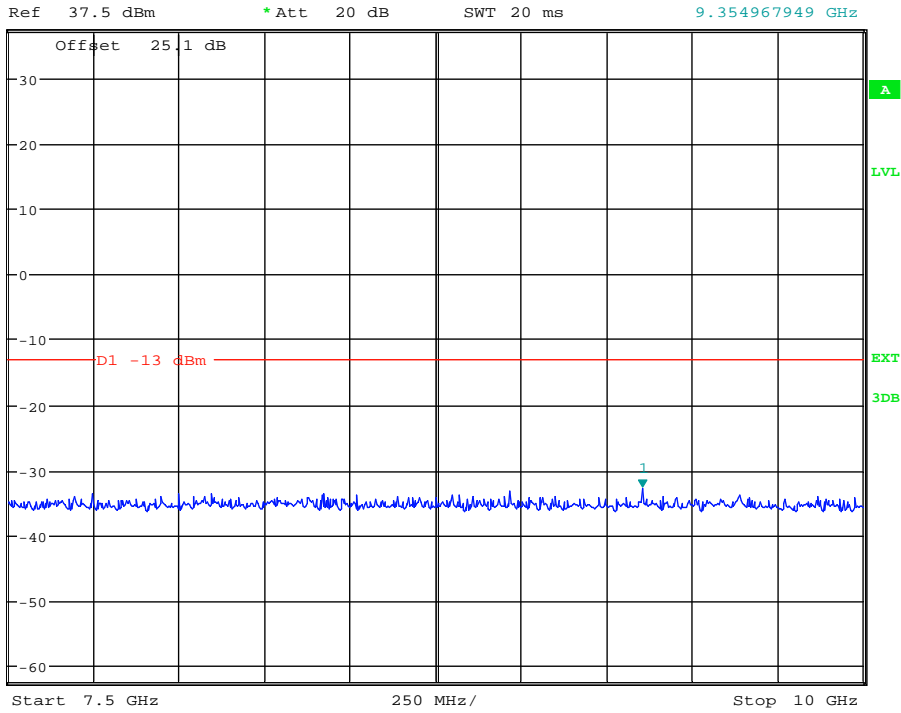

Date: 2.JAN.2014 15:51:30

(Plot 4.7.2 A4: Channel 190: 836.60MHz @ Traffic @ GSM850)



Ref 37.5 dBm * Att 20 dB * RBW 1 MHz Marker 1 [T1] 32.44 dBm
* VBW 3 MHz 850.769230769 MHz
SWT 2.5 ms

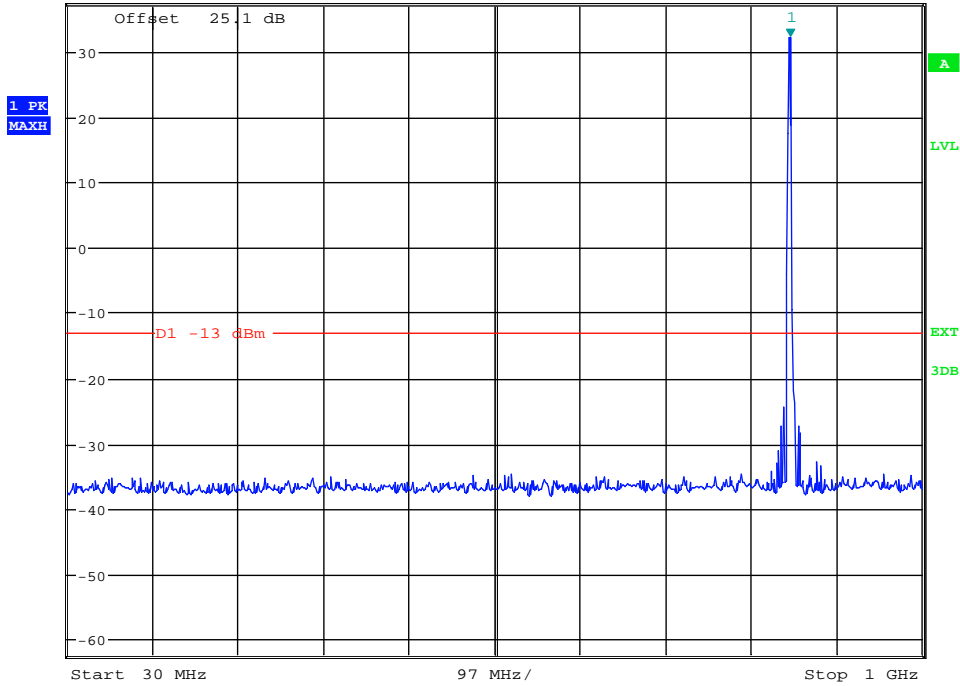

Date: 2.JAN.2014 15:51:53

(Plot 4.7.3 A1: Channel 251: 848.80MHz @ Traffic @ GSM850)



Ref 37.5 dBm * Att 20 dB * RBW 1 MHz Marker 1 [T1] -27.84 dBm
* VBW 3 MHz 1.697115385 GHz
SWT 5 ms

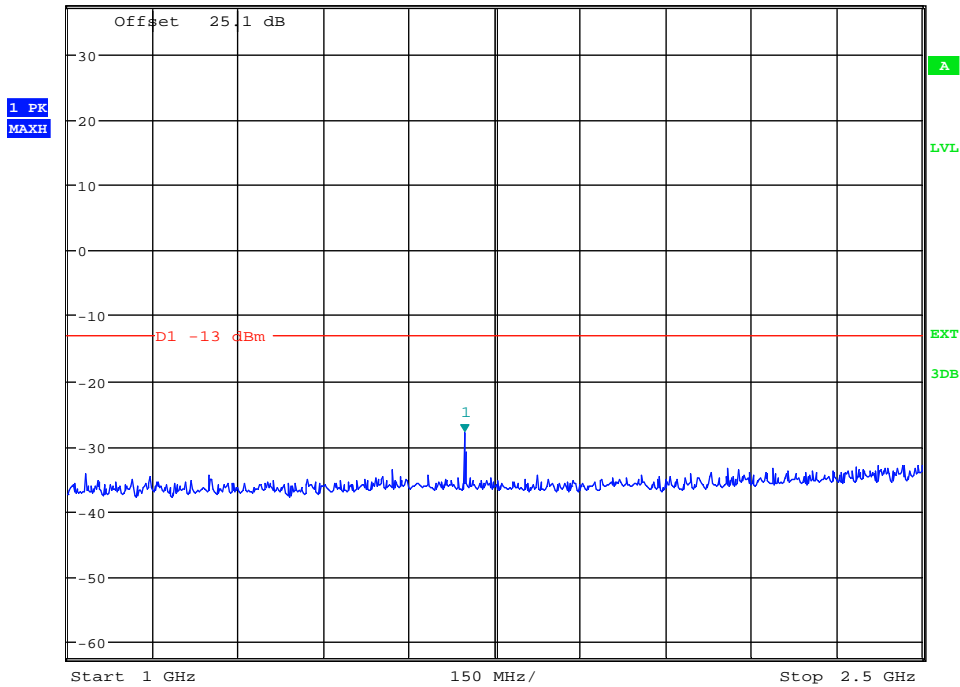

Date: 2.JAN.2014 15:52:08

(Plot 4.7.3 A2: Channel 251: 848.80MHz @ Traffic @ GSM850)



*RBW 1 MHz Marker 1 [T1]
*VBW 3 MHz -30.49 dBm
SWT 30 ms 3.485576923 GHz

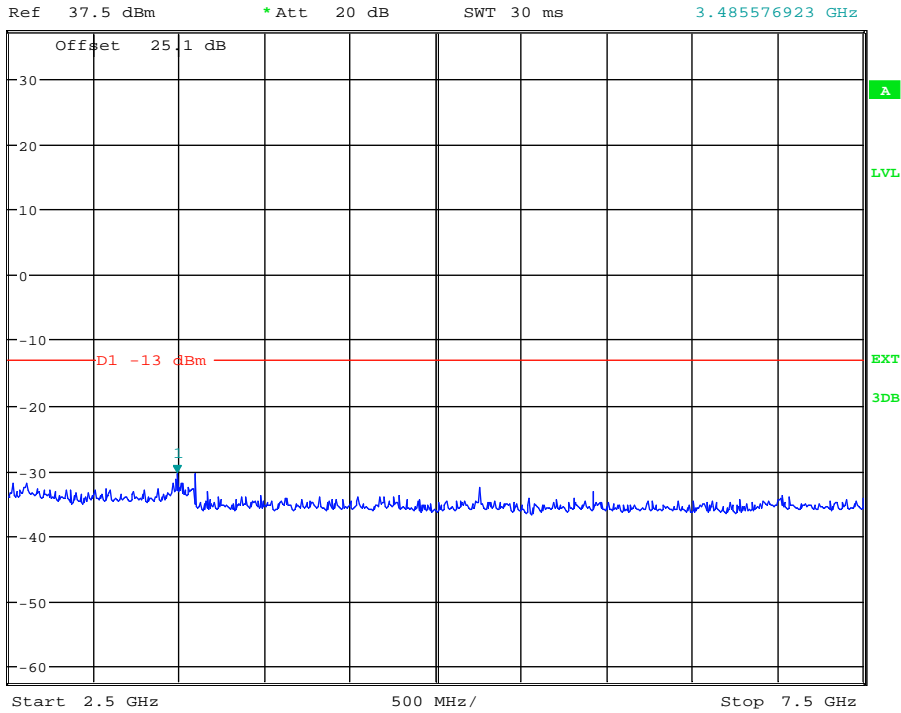

Date: 2.JAN.2014 15:52:27

(Plot 4.7.3 A3: Channel 251: 848.80MHz @ Traffic @ GSM850)



*RBW 1 MHz Marker 1 [T1]
*VBW 3 MHz -33.07 dBm
SWT 20 ms 9.879807692 GHz

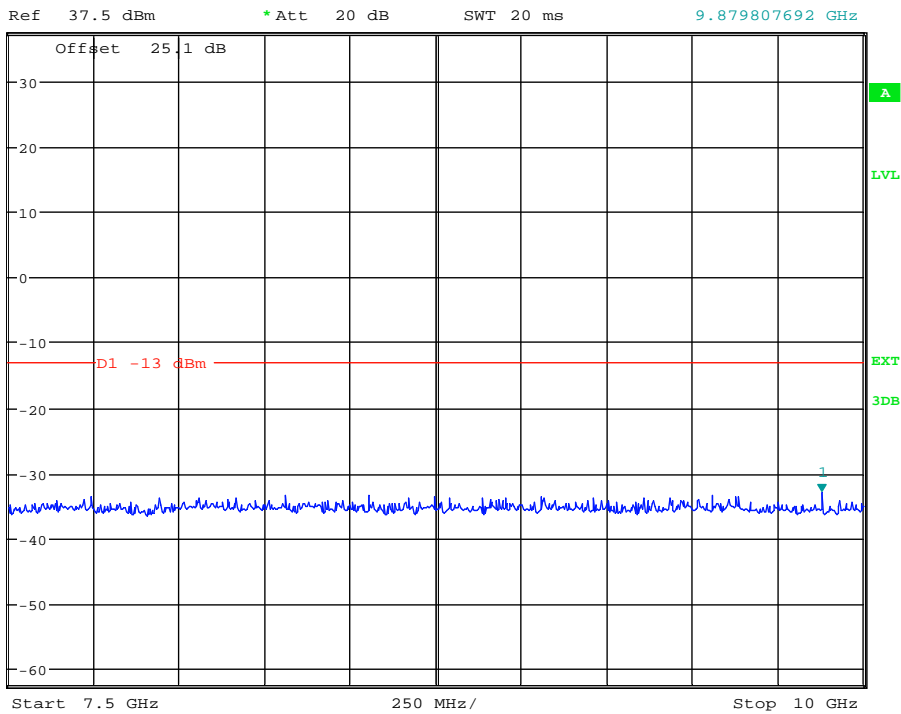

Date: 2.JAN.2014 15:52:45

(Plot 4.7.3 A4: Channel 251: 848.80MHz @ Traffic @ GSM850)



*RBW 1 MHz Marker 1 [T1]
*VBW 3 MHz -34.39 dBm
SWT 2.5 ms 626.923076923 MHz

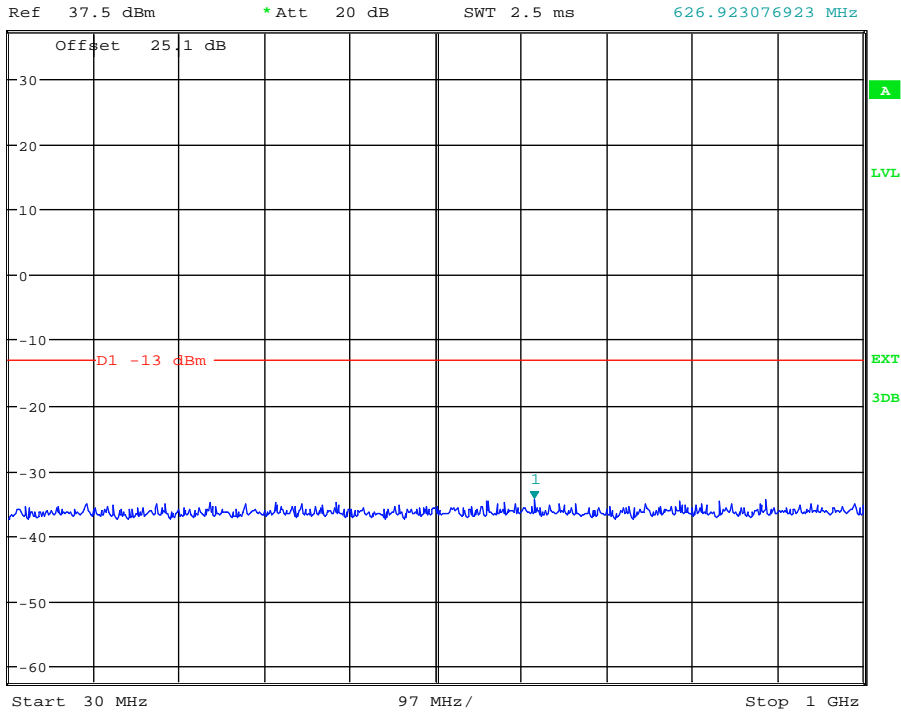

Date: 2.JAN.2014 15:53:49

(Plot 4.7.4 A1: Idle @ GSM850)



*RBW 1 MHz Marker 1 [T1]
*VBW 3 MHz -32.92 dBm
SWT 5 ms 2.471153846 GHz

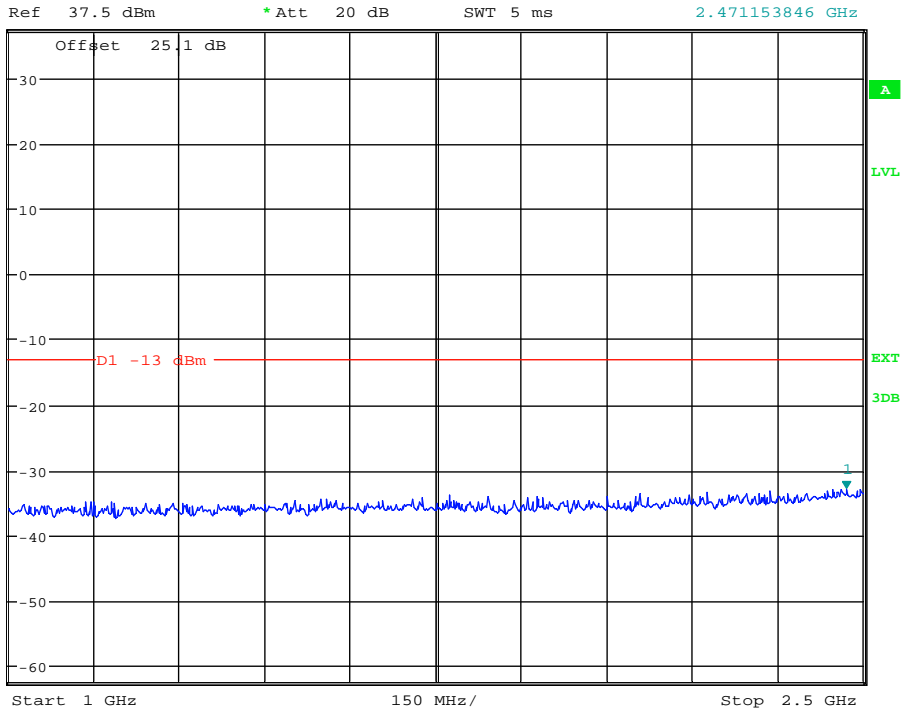

Date: 2.JAN.2014 15:54:55

(Plot 4.7.4 A2: Idle @ GSM850)



*RBW 1 MHz Marker 1 [T1]
*VBW 3 MHz -31.72 dBm
SWT 30 ms 2.532051282 GHz

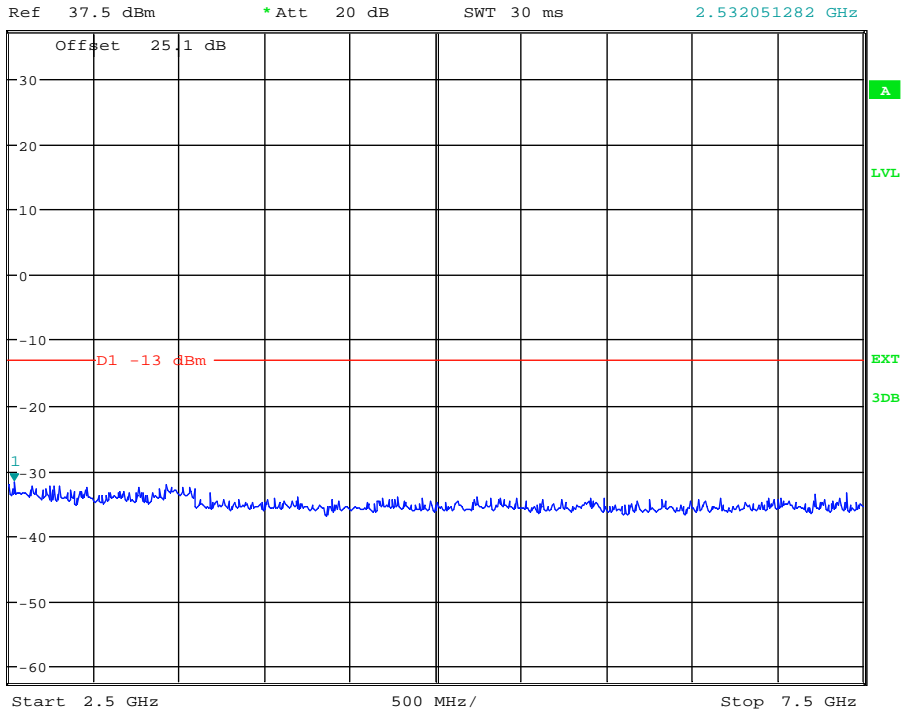

Date: 2.JAN.2014 15:55:15

(Plot 4.7.4 A3: Idle @ GSM850)



*RBW 1 MHz Marker 1 [T1]
*VBW 3 MHz -33.31 dBm
SWT 20 ms 7.644230769 GHz

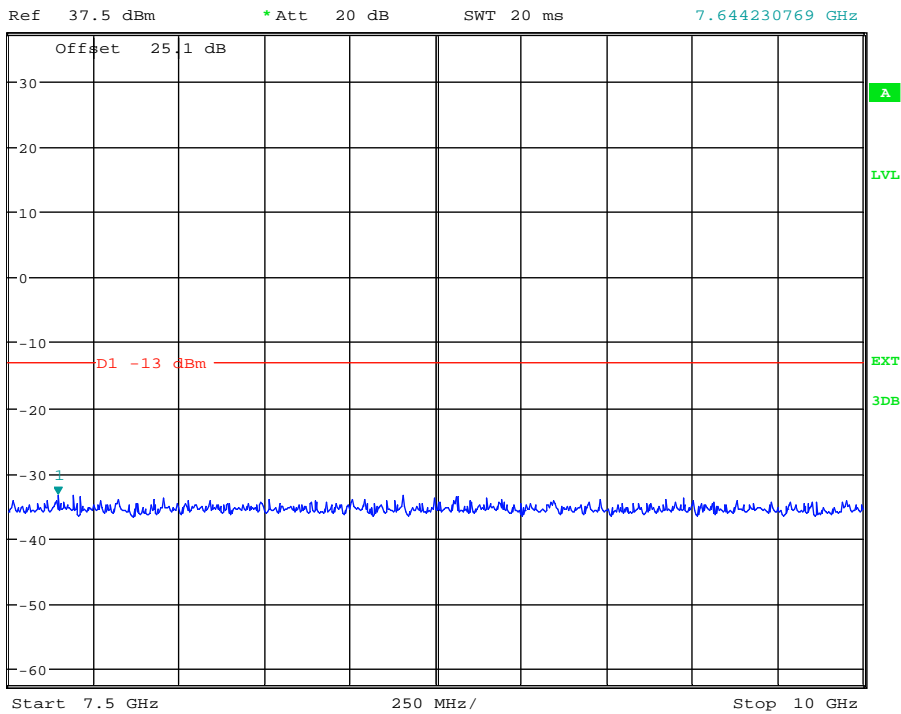

Date: 2.JAN.2014 15:55:42

(Plot 4.7.4 A4: Idle @ GSM850)

GPRS1900						
Channel Number: 512		Test Frequency: 1850.20 MHz			Test Mode: Traffic	
Start Frequency (MHz)	Stop Frequency (MHz)	Measurement Results		Limit (dBm)	Refer to Plot	Verdict
		Frequency (MHz)	Values (dBm)			
30	1000	923.83	-34.30	-13.00	Plot 4.7.5 A1	PASS
1000	2500	***	***	-13.00	Plot 4.7.5 A2	PASS
2500	7500	2532.05	-31.20	-13.00	Plot 4.7.5 A3	PASS
7500	10000	9102.56	-32.42	-13.00	Plot 4.7.5 A4	PASS
10000	15000	12427.88	-32.97	-13.00	Plot 4.7.5 A5	PASS
15000	20000	18125.00	-31.42	-13.00	Plot 4.7.5 A6	PASS

GPRS1900						
Channel Number: 661		Test Frequency: 1880.00 MHz			Test Mode: Traffic	
Start Frequency (MHz)	Stop Frequency (MHz)	Measurement Results		Limit (dBm)	Refer to Plot	Verdict
		Frequency (MHz)	Values (dBm)			
30	1000	940.93	-34.32	-13.00	Plot 4.7.6 A1	PASS
1000	2500	***	***	-13.00	Plot 4.7.6 A2	PASS
2500	7500	3573.72	-30.79	-13.00	Plot 4.7.6 A3	PASS
7500	10000	8830.13	-32.89	-13.00	Plot 4.7.6 A4	PASS
10000	15000	13461.54	-33.40	-13.00	Plot 4.7.6 A5	PASS
15000	20000	19463.14	-31.98	-13.00	Plot 4.7.6 A6	PASS

GPRS1900						
Channel Number: 810		Test Frequency: 1909.80 MHz			Test Mode: Traffic	
Start Frequency (MHz)	Stop Frequency (MHz)	Measurement Results		Limit (dBm)	Refer to Plot	Verdict
		Frequency (MHz)	Values (dBm)			
30	1000	846.09	-34.33	-13.00	Plot 4.7.7 A1	PASS
1000	2500	***	***	-13.00	Plot 4.7.7 A2	PASS
2500	7500	3397.44	-32.23	-13.00	Plot 4.7.7 A3	PASS
7500	10000	8445.51	-33.06	-13.00	Plot 4.7.7 A4	PASS
10000	15000	14230.77	-32.97	-13.00	Plot 4.7.7 A5	PASS
15000	20000	19631.14	-31.75	-13.00	Plot 4.7.7 A6	PASS

GPRS1900						
Test Mode: Idle						
Start Frequency (MHz)	Stop Frequency (MHz)	Measurement Results		Limit (dBm)	Refer to Plot	Verdict
		Frequency (MHz)	Values (dBm)			
30	1000	149.70	-34.15	-13.00	Plot 4.7.8 A1	PASS
1000	2500	2492.79	-31.76	-13.00	Plot 4.7.8 A2	PASS
2500	7500	2788.14	-31.71	-13.00	Plot 4.7.8 A3	PASS
7500	10000	8381.41	-32.62	-13.00	Plot 4.7.8 A4	PASS
10000	15000	12796.47	-33.07	-13.00	Plot 4.7.8 A5	PASS
15000	20000	17700.32	-32.22	-13.00	Plot 4.7.8 A6	PASS

Note: 1. In general, the worse case attenuation requirement shown above was applied.

2. *** means that the emission level is too low to be measured or at least 20 dB down than the limit.



*RBW 1 MHz Marker 1 [T1]
*VBW 3 MHz -34.30 dBm
SWT 2.5 ms 923.830128205 MHz

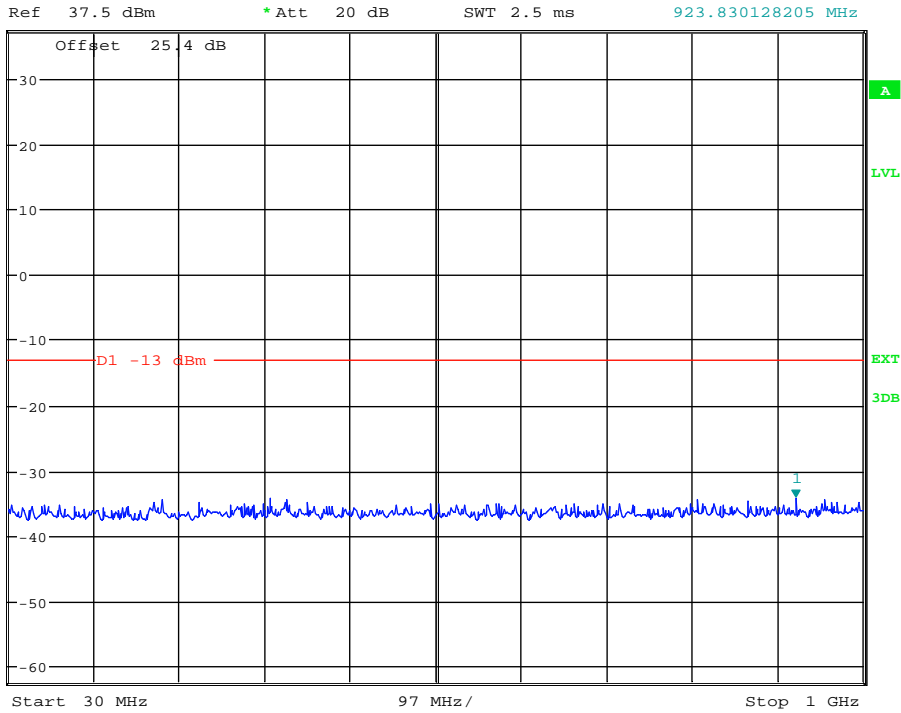

Date: 2.JAN.2014 16:23:31

(Plot 4.7.5 A1: Channel 512: 1850.20MHz @ Traffic @ PCS1900)



*RBW 1 MHz Marker 1 [T1]
*VBW 3 MHz 30.40 dBm
SWT 5 ms 1.850961538 GHz

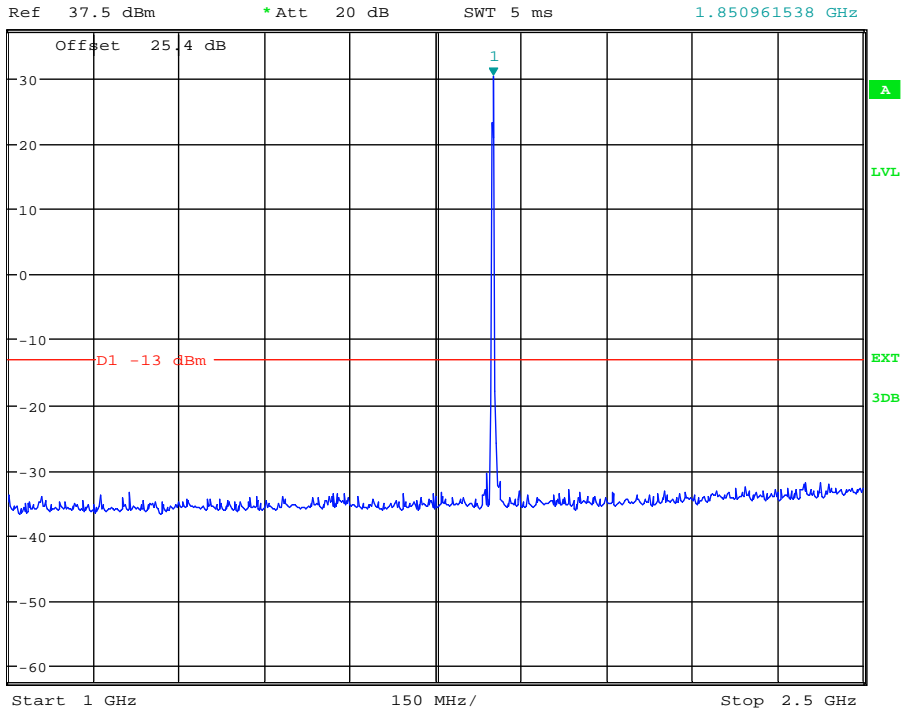

Date: 2.JAN.2014 16:23:58

(Plot 4.7.5 A2: Channel 512: 1850.20MHz @ Traffic @ PCS1900)



*RBW 1 MHz Marker 1 [T1]
*VBW 3 MHz -31.20 dBm
SWT 30 ms 2.532051282 GHz

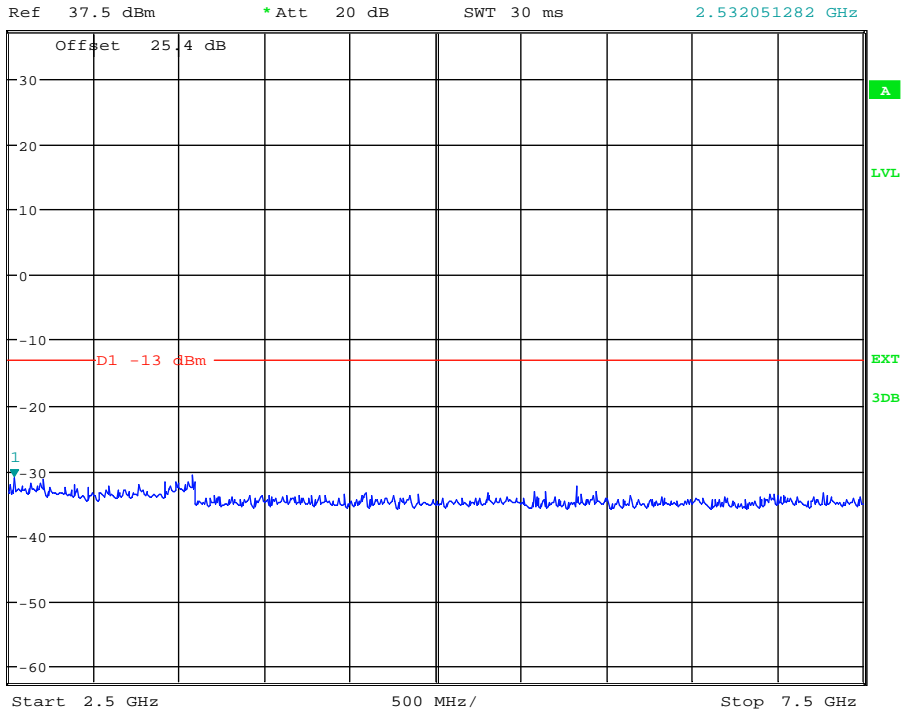

Date: 2.JAN.2014 16:24:38

(Plot 4.7.5 A3: Channel 512: 1850.20MHz @ Traffic @ PCS1900)



*RBW 1 MHz Marker 1 [T1]
*VBW 3 MHz -32.42 dBm
SWT 20 ms 9.102564103 GHz

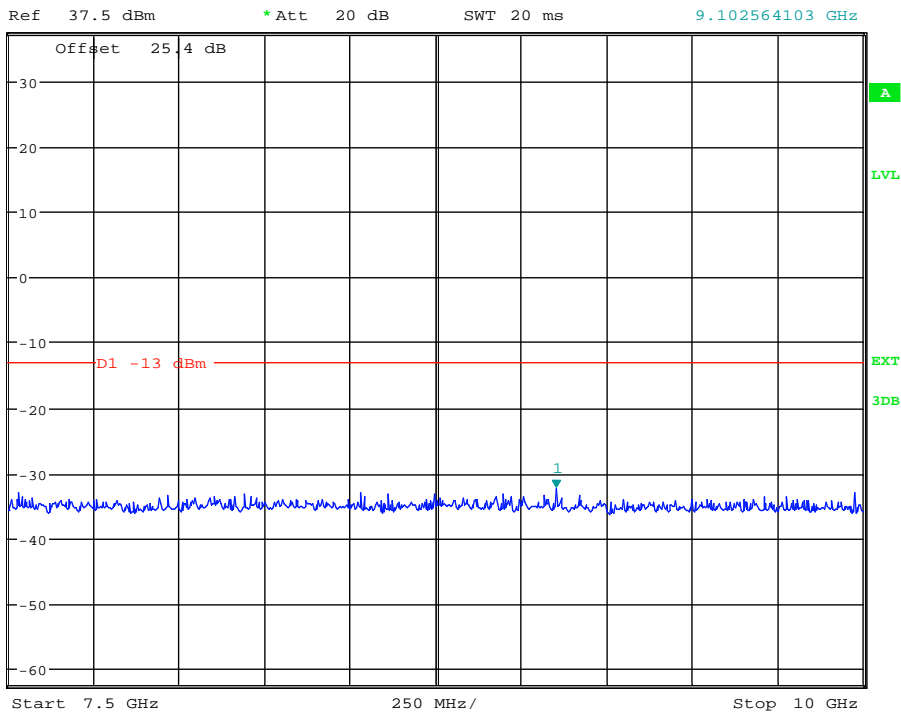

Date: 2.JAN.2014 16:24:55

(Plot 4.7.5 A4: Channel 512: 1850.20MHz @ Traffic @ PCS1900)



*RBW 1 MHz Marker 1 [T1]
*VBW 3 MHz -32.97 dBm
SWT 30 ms 12.427884615 GHz

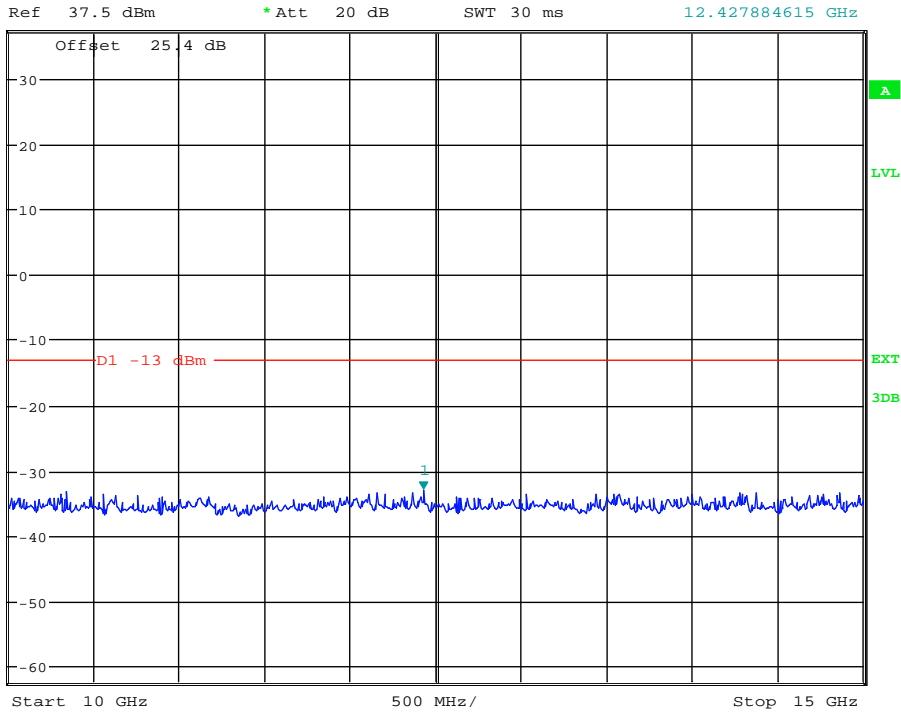

Date: 2.JAN.2014 16:25:49

(Plot 4.7.5 A5: Channel 512: 1850.20MHz @ Traffic @ PCS1900)



*RBW 1 MHz Marker 1 [T1]
*VBW 3 MHz -31.42 dBm
SWT 30 ms 18.125000000 GHz

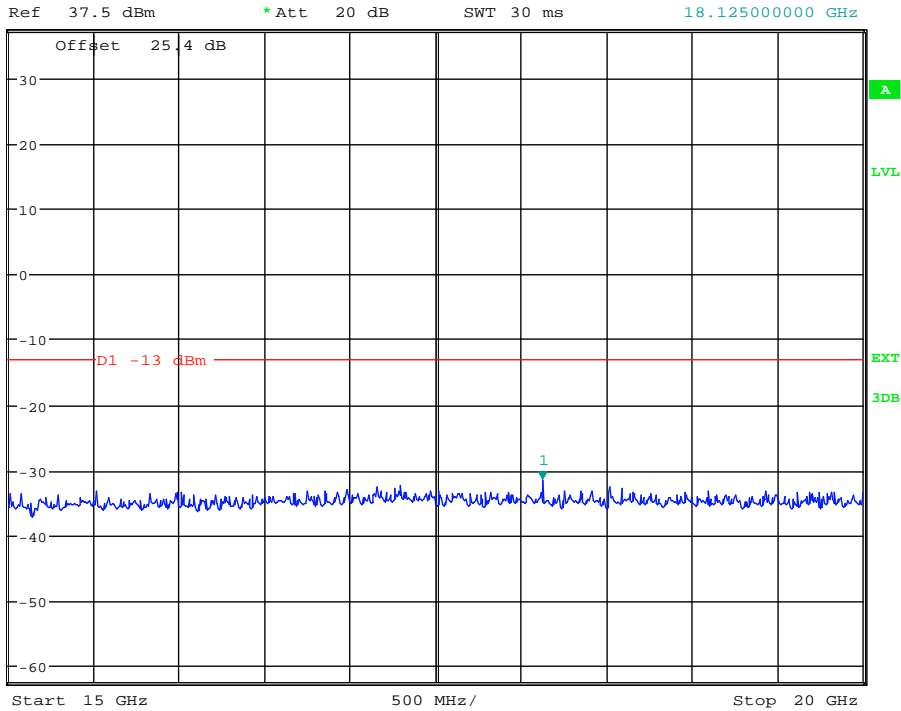

Date: 2.JAN.2014 16:26:01

(Plot 4.7.5 A6: Channel 512: 1850.20MHz @ Traffic @ PCS1900)



*RBW 1 MHz Marker 1 [T1]
*VBW 3 MHz -34.32 dBm
SWT 2.5 ms 940.929487179 MHz

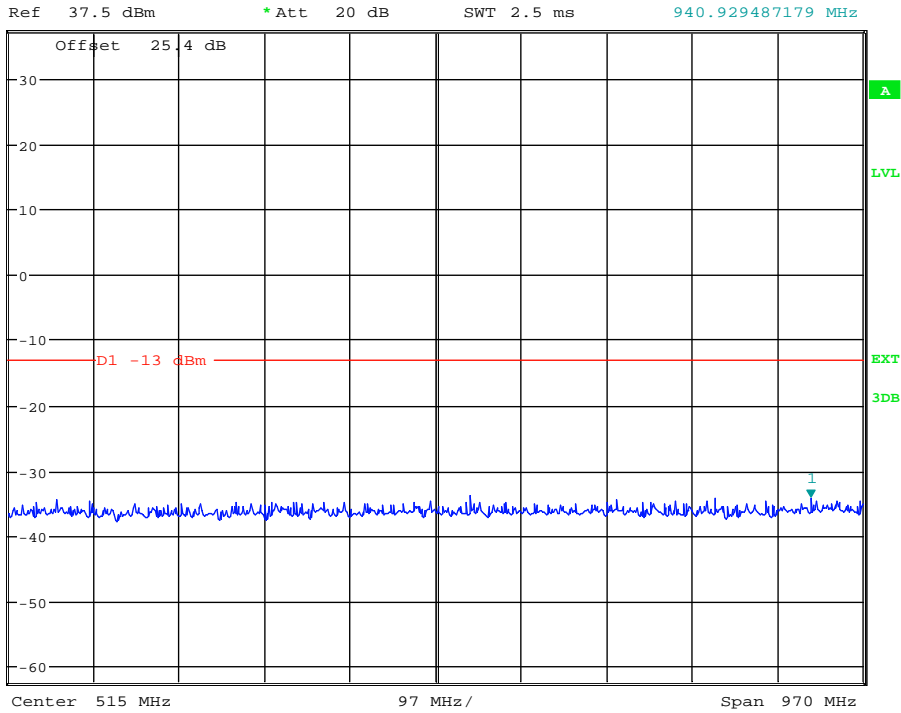

Date: 2.JAN.2014 16:28:08

(Plot 4.7.6 A1: Channel 661: 1880.00MHz @ Traffic @ PCS1900)



*RBW 1 MHz Marker 1 [T1]
*VBW 3 MHz 29.73 dBm
SWT 5 ms 1.882211538 GHz

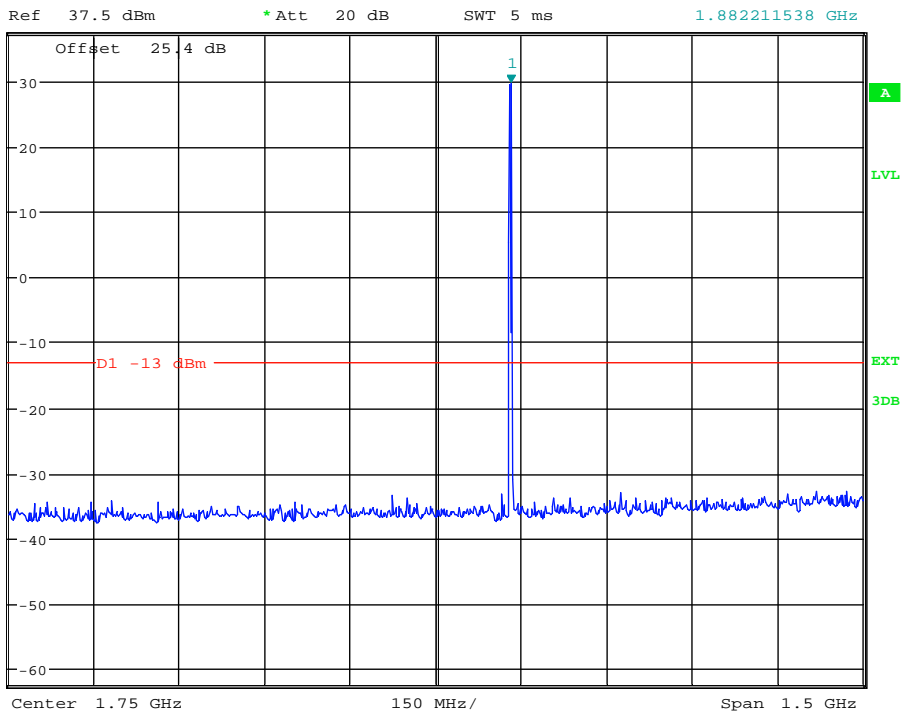

Date: 2.JAN.2014 16:27:57

(Plot 4.7.6 A2: Channel 661: 1880.00MHz @ Traffic @ PCS1900)



*RBW 1 MHz Marker 1 [T1]
*VBW 3 MHz -30.79 dBm
SWT 30 ms 3.573717949 GHz

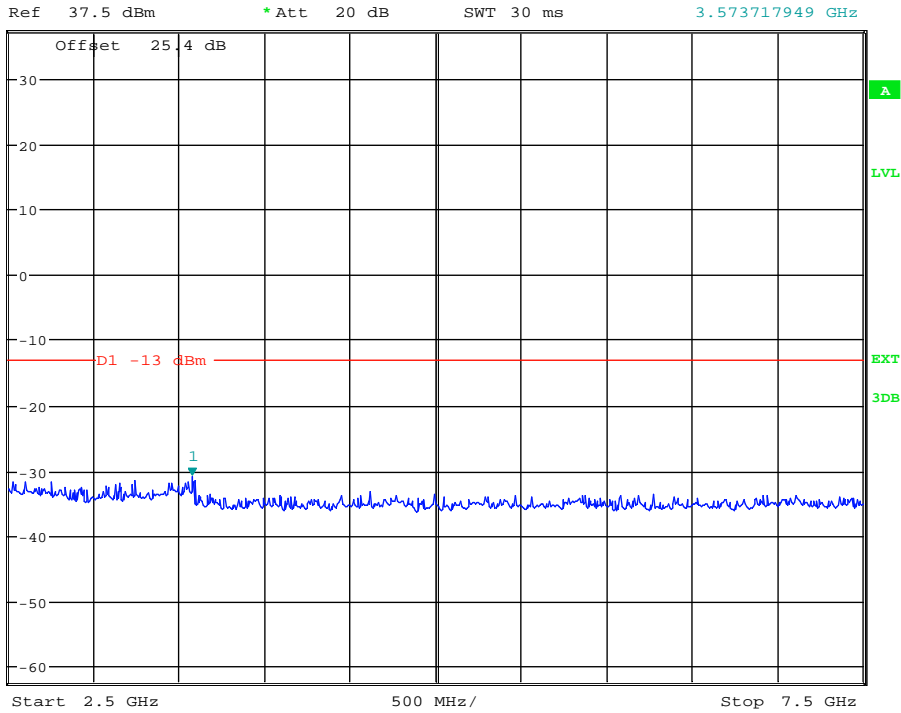

Date: 2.JAN.2014 16:28:28

(Plot 4.7.6 A3: Channel 661: 1880.00MHz @ Traffic @ PCS1900)



*RBW 1 MHz Marker 1 [T1]
*VBW 3 MHz -32.89 dBm
SWT 20 ms 8.830128205 GHz

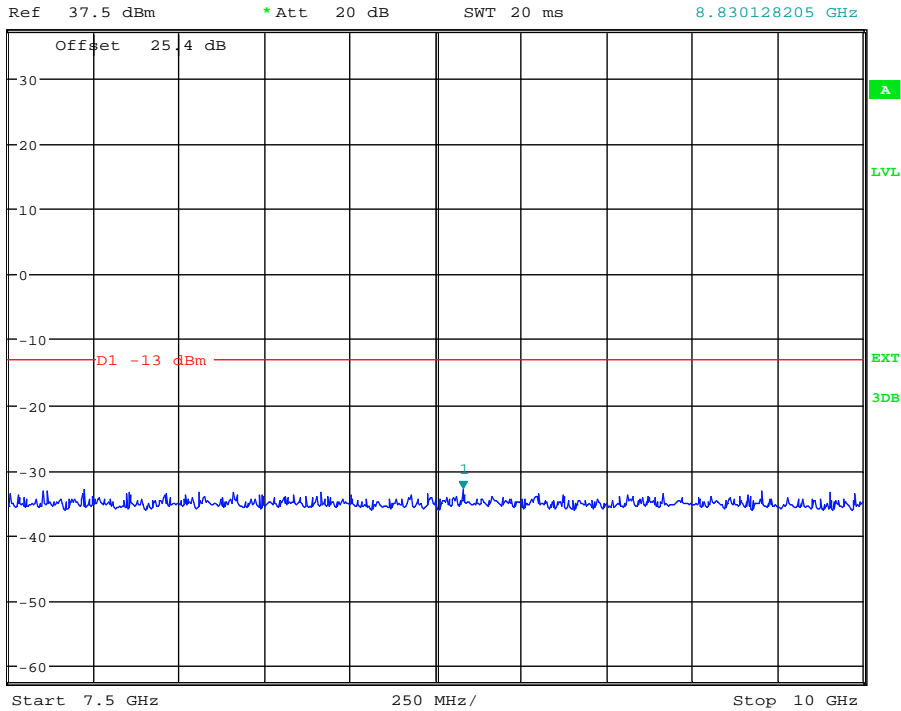

Date: 2.JAN.2014 16:28:54

(Plot 4.7.6 A4: Channel 661: 1880.00MHz @ Traffic @ PCS1900)



*RBW 1 MHz Marker 1 [T1]
*VBW 3 MHz -33.40 dBm
SWT 30 ms 13.461538462 GHz

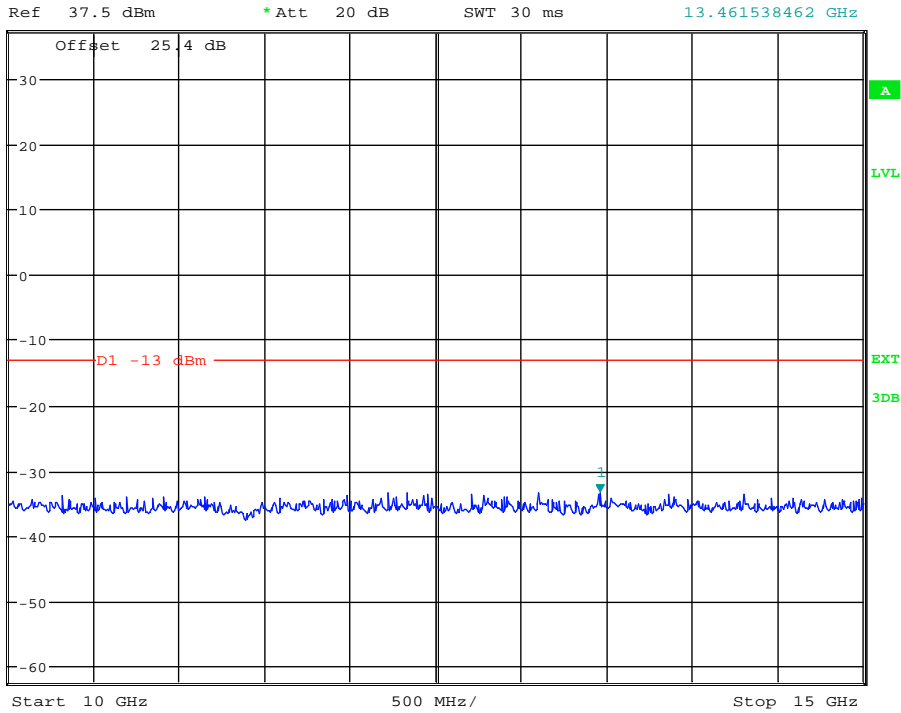

Date: 2.JAN.2014 16:29:52

(Plot 4.7.6 A5: Channel 661: 1880.00MHz @ Traffic @ PCS1900)



*RBW 1 MHz Marker 1 [T1]
*VBW 3 MHz -31.95 dBm
SWT 30 ms 19.463141026 GHz

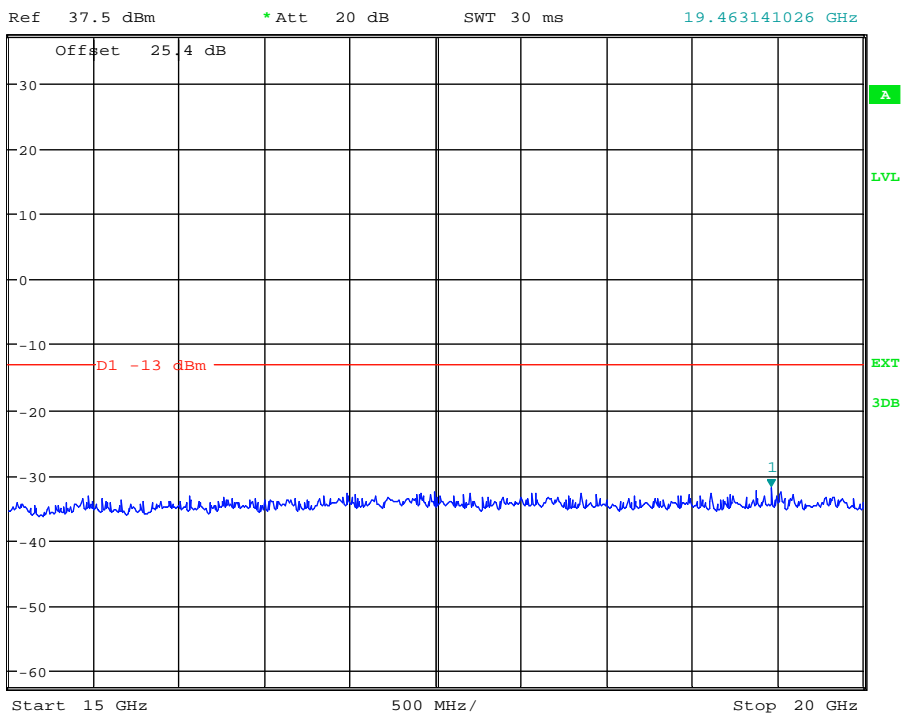

Date: 2.JAN.2014 16:30:07

(Plot 4.7.6 A6: Channel 661: 1880.00MHz @ Traffic @ PCS1900)



*RBW 1 MHz Marker 1 [T1]
*VBW 3 MHz -34.33 dBm
SWT 2.5 ms 546.089743590 MHz

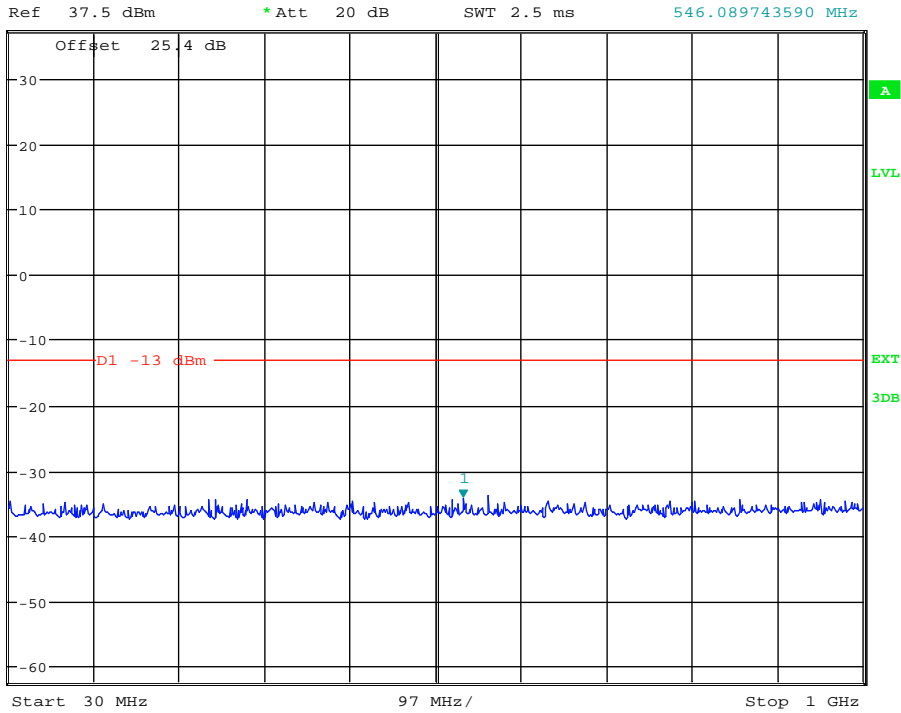

Date: 2.JAN.2014 16:31:26

(Plot 4.7.7 A1: Channel 810: 1909.80MHz @ Traffic @ PCS190)



*RBW 1 MHz Marker 1 [T1]
*VBW 3 MHz 29.53 dBm
SWT 5 ms 1.911057692 GHz

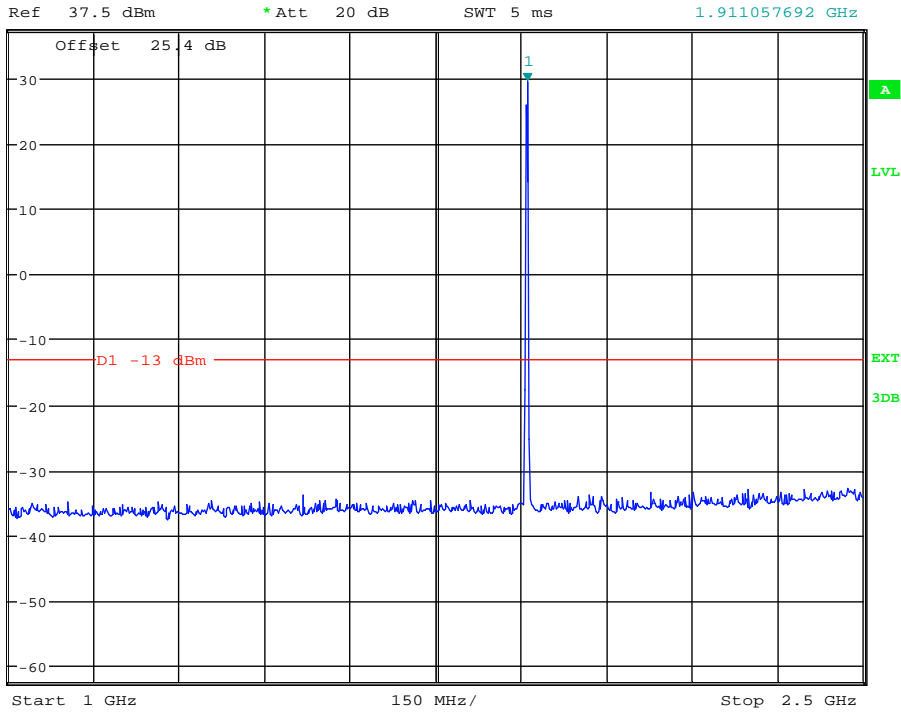

Date: 2.JAN.2014 16:31:47

(Plot 4.7.7 A2: Channel 810: 1909.80MHz @ Traffic @ PCS190)



*RBW 1 MHz Marker 1 [T1]
*VBW 3 MHz -32.23 dBm
SWT 30 ms 3.397435897 GHz

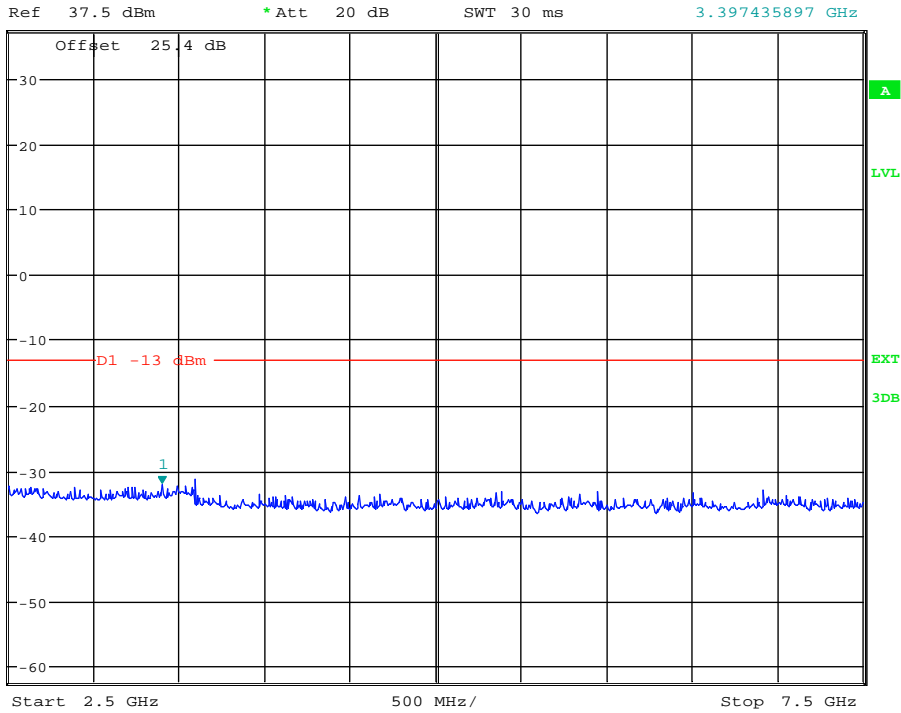

Date: 2.JAN.2014 16:32:32

(Plot 4.7.7 A3: Channel 810: 1909.80MHz @ Traffic @ PCS1900)



*RBW 1 MHz Marker 1 [T1]
*VBW 3 MHz -33.06 dBm
SWT 20 ms 8.445512821 GHz

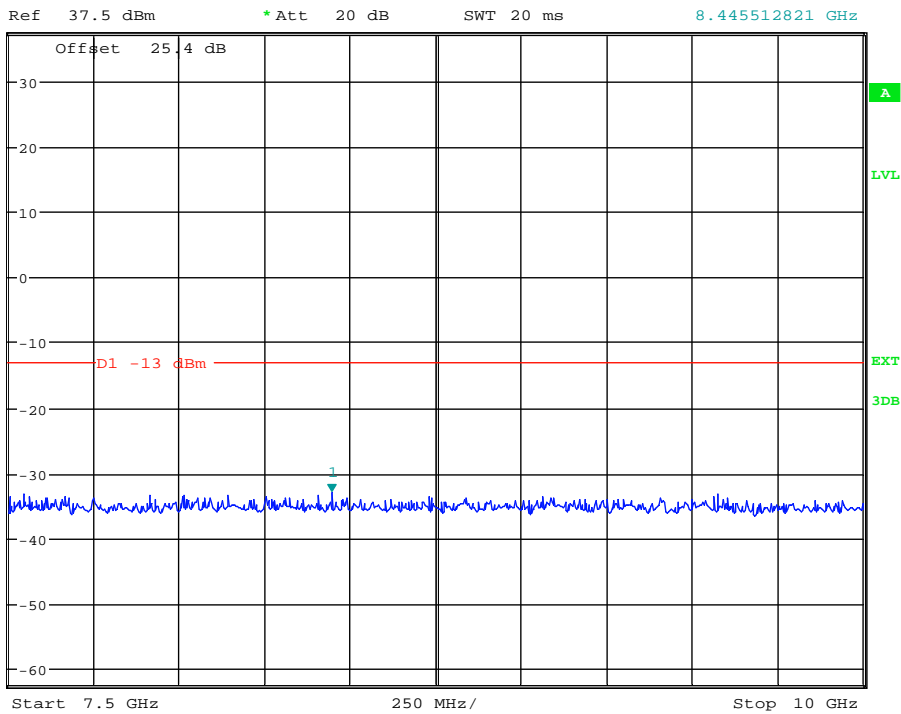

Date: 2.JAN.2014 16:32:48

(Plot 4.7.7 A4: Channel 810: 1909.80MHz @ Traffic @ PCS1900)



*RBW 1 MHz Marker 1 [T1]
*VBW 3 MHz -32.97 dBm
SWT 30 ms 14.230769231 GHz

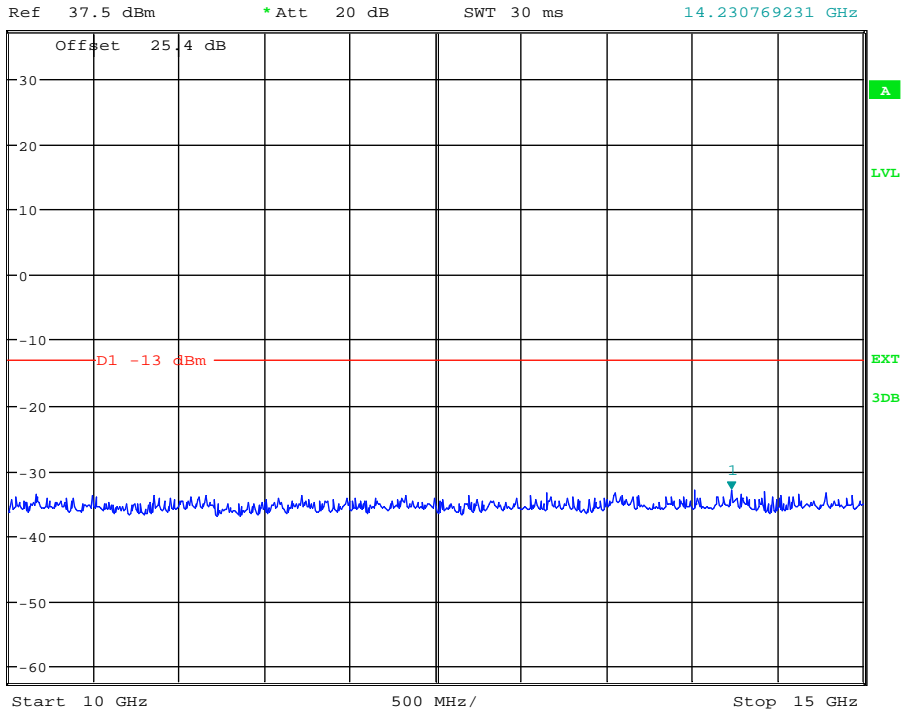

Date: 2.JAN.2014 16:33:20

(Plot 4.7.7 A5: Channel 810: 1909.80MHz @ Traffic @ PCS1900)



*RBW 1 MHz Marker 1 [T1]
*VBW 3 MHz -31.75 dBm
SWT 30 ms 19.631410256 GHz

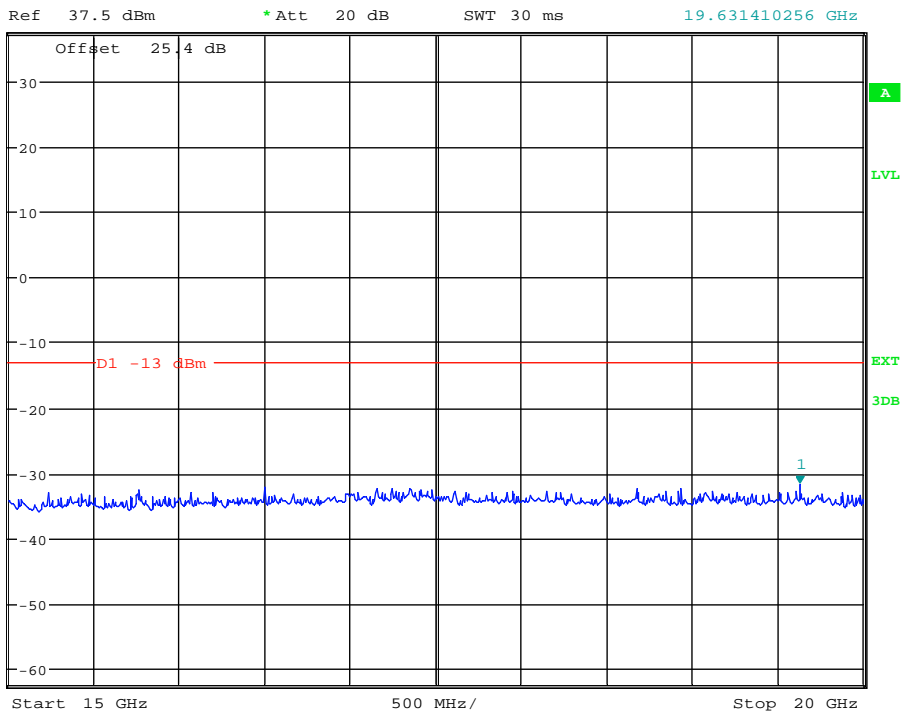

Date: 2.JAN.2014 16:33:40

(Plot 4.7.7 A6: Channel 810: 1909.80MHz @ Traffic @ PCS1900)



*RBW 1 MHz Marker 1 [T1]
*VBW 3 MHz -34.15 dBm
SWT 2.5 ms 149.695512821 MHz

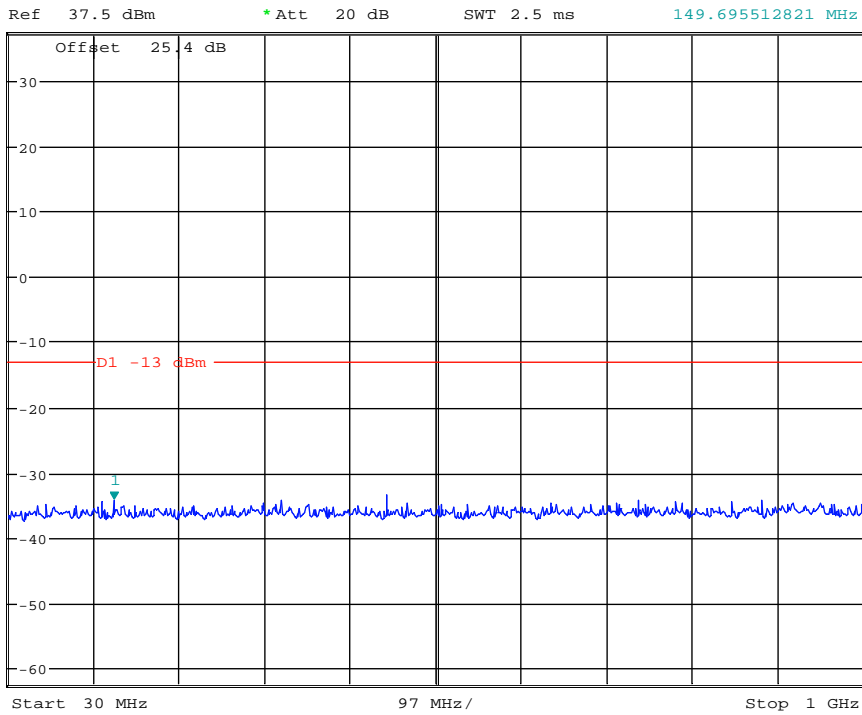

Date: 2.JAN.2014 16:34:41

(Plot 4.7.8 A1: Idle @ PCS1900)



*RBW 1 MHz Marker 1 [T1]
*VBW 3 MHz -31.76 dBm
SWT 5 ms 2.492788462 GHz

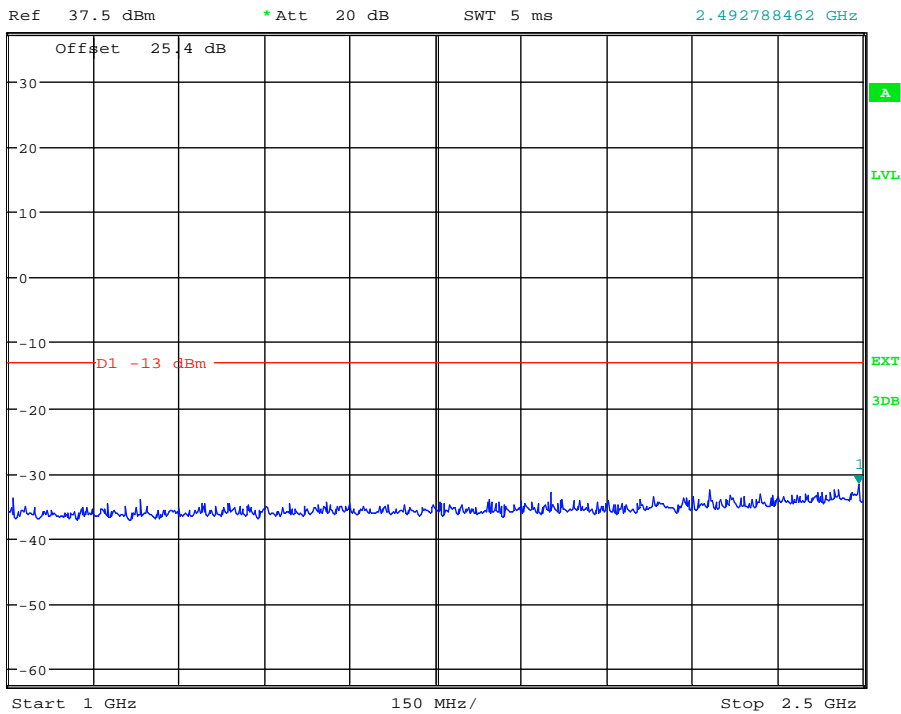

Date: 2.JAN.2014 16:35:14

(Plot 4.7.8 A2: Idle @ PCS1900)



*RBW 1 MHz Marker 1 [T1]
*VBW 3 MHz -31.71 dBm
SWT 30 ms 2.588141026 GHz

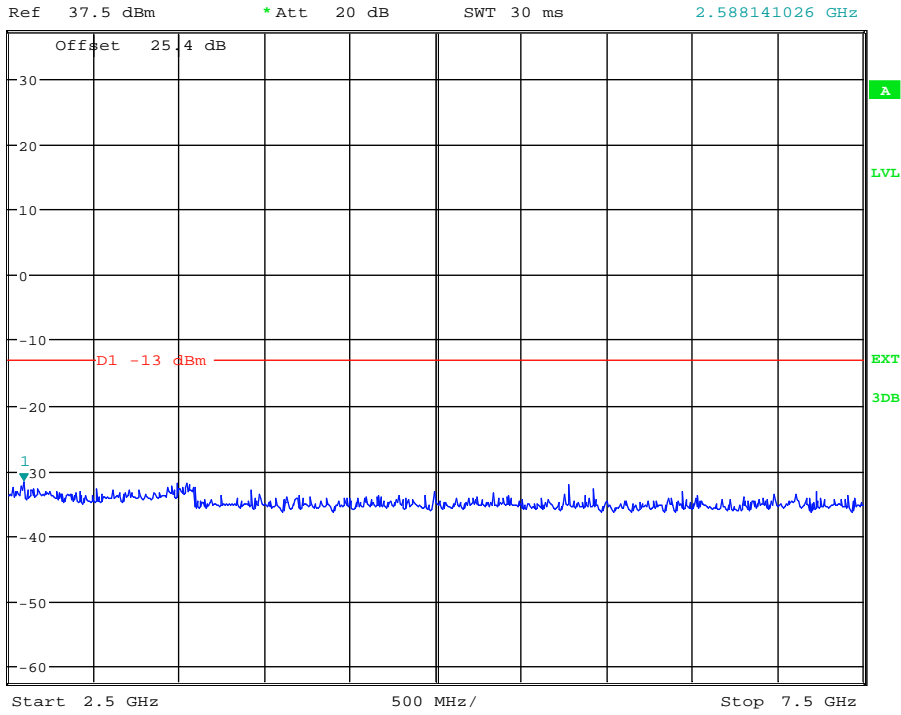

Date: 2.JAN.2014 16:35:26

(Plot 4.7.8 A3: Idle @ PCS1900)



*RBW 1 MHz Marker 1 [T1]
*VBW 3 MHz -32.62 dBm
SWT 20 ms 8.381410256 GHz

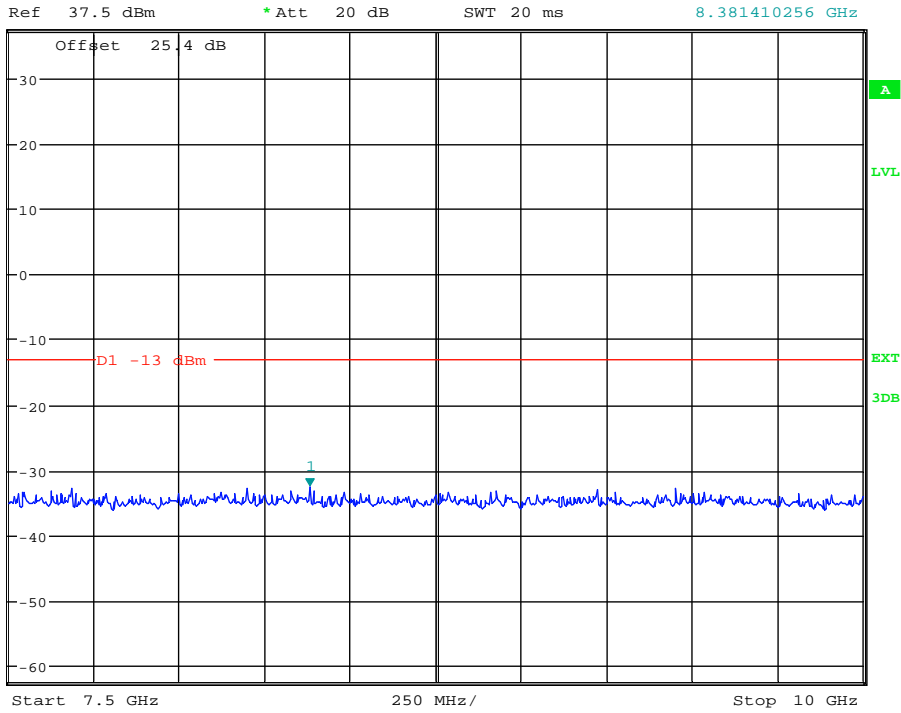

Date: 2.JAN.2014 16:35:55

(Plot 4.7.8 A4: Idle @ PCS1900)



*RBW 1 MHz Marker 1 [T1]
*VBW 3 MHz -33.07 dBm
SWT 30 ms 12.796474359 GHz

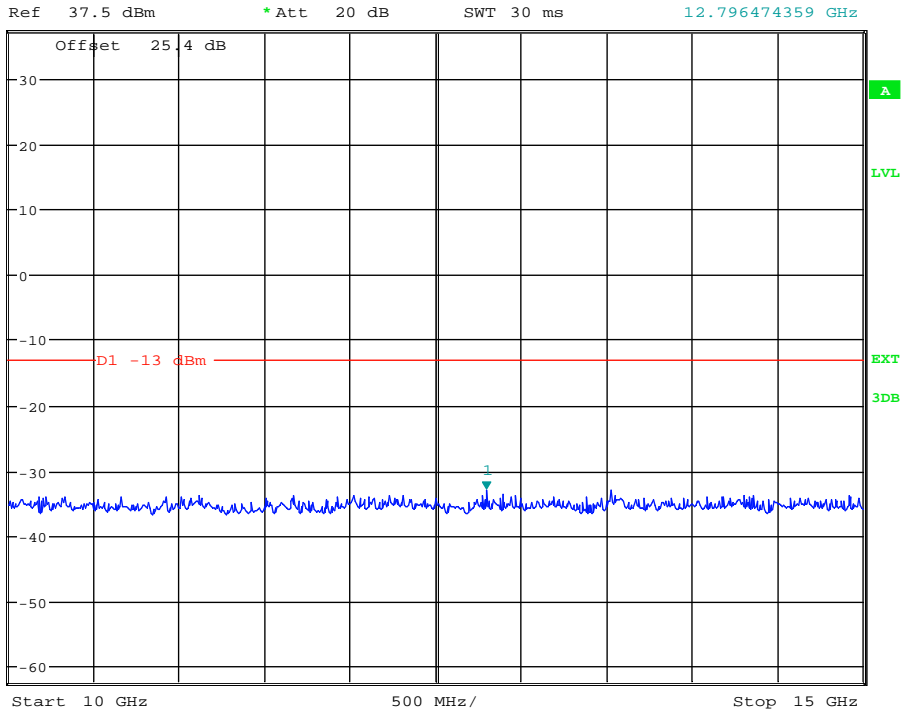

Date: 2.JAN.2014 16:36:17

(Plot 4.7.8 A5: Idle @ PCS1900)



*RBW 1 MHz Marker 1 [T1]
*VBW 3 MHz -32.22 dBm
SWT 30 ms 17.700320513 GHz

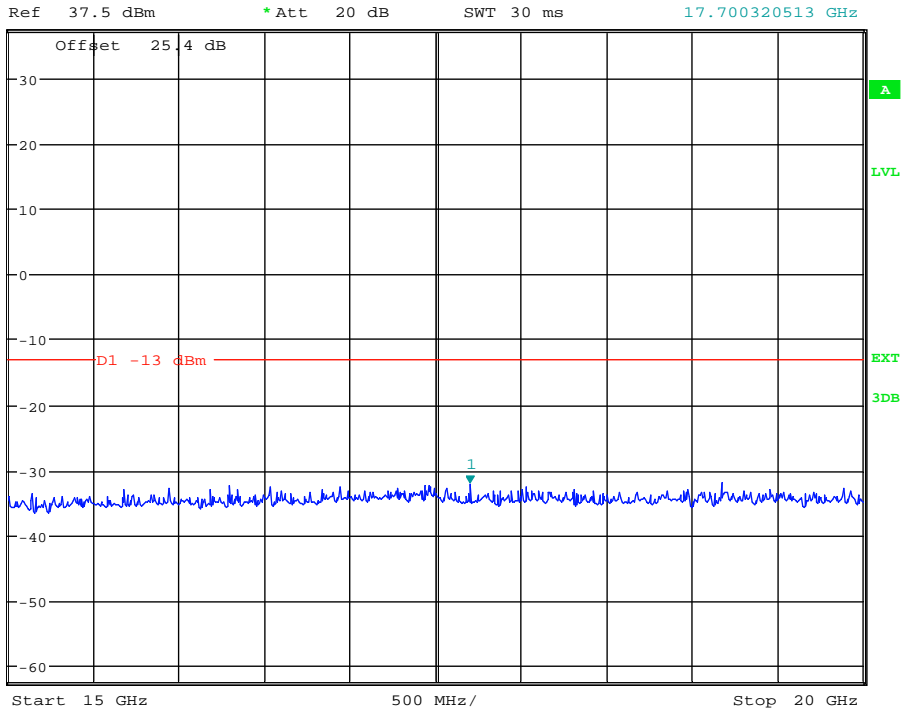

Date: 2.JAN.2014 16:36:42

(Plot 4.7.8 A6: Idle @ PCS1900)

4.8. Frequency Stability Test

TEST APPLICABLE

1. According to FCC Part 2 Section 2.1055 (a)(1), the frequency stability shall be measured with variation of ambient temperature from -30°C to +50°C centigrade.
2. According to FCC Part 2 Section 2.1055 (e) (2), for battery powered equipment, the frequency stability shall be measured with reducing primary supply voltage to the battery operating end point, which is specified by the manufacture.
3. Vary primary supply voltage from 85 to 115 percent of the nominal value for other than hand carried voltage equipment.

TEST PROCEDURE

In order to measure the carrier frequency under the condition of AFC lock, it is necessary to make measurements with the EUT in a "call mode". This is accomplished with the use of R&S CMU200 DIGITAL RADIO COMMUNICATION TESTER.

1. Measure the carrier frequency at room temperature;
2. Subject the EUT to overnight soak at -30°C;
3. With the EUT, powered via nominal voltage, connected to the CMU200 and in a simulated call on middle channel of PCS 1900 and GSM850, measure the carrier frequency. These measurements should be made within 2 minutes of Powering up the EUT, to prevent significant self-warming;
4. Repeat the above measurements at 10°C increments from -30°C to +50°C. Allow at least 0.5 hours at each temperature, unpowered, before making measurements;
5. Remeasure carrier frequency at room temperature with nominal voltage. Vary supply voltage from minimum voltage to maximum voltage, in 0.1Volt increments remeasuring carrier frequency at each voltage. Pause at nominal voltage for 0.5 hours unpowered, to allow any self-heating to stabilize, before continuing;
6. Subject the EUT to overnight soak at +50°C;
7. With the EUT, powered via nominal voltage, connected to the CMU200 and in a simulated call on the centre channel, measure the carrier frequency. These measurements should be made within 2 minutes of Powering up the EUT, to prevent significant self-warming;
8. Repeat the above measurements at 10°C increments from +50°C to -30°C. Allow at least 0.5 hours at each temperature, unpowered, before making measurements;
9. At all temperature levels hold the temperature to +/- 0.5°C during the measurement procedure;

TEST CONFIGURATION

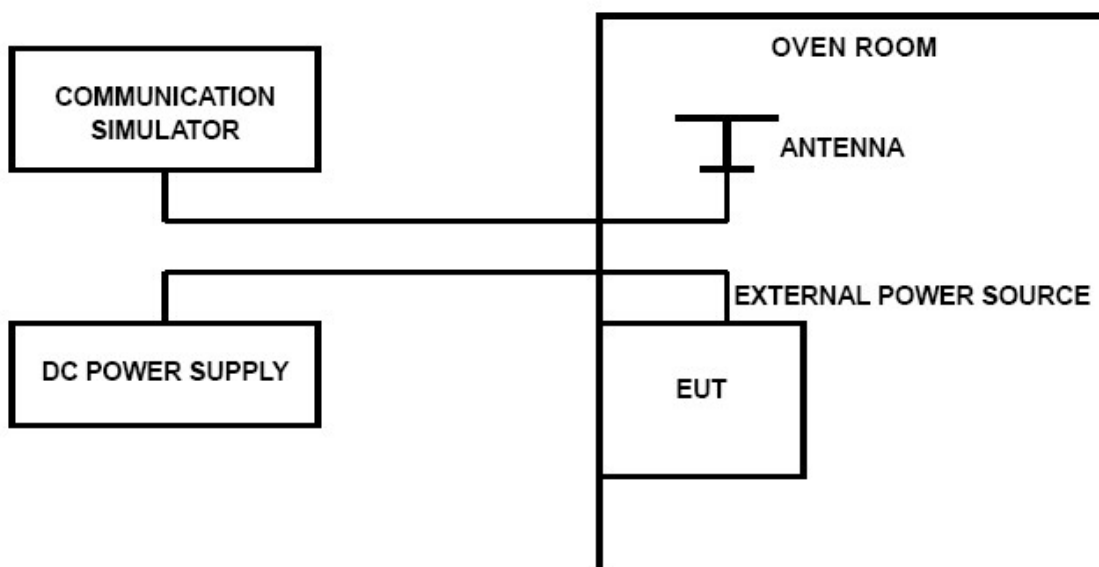

TEST LIMITS

For Hand carried battery powered equipment

According to the JTC standard the frequency stability of the carrier shall be accurate to within 0.1 ppm of the received frequency from the base station. This accuracy is sufficient to meet Sec. 24.235, Frequency Stability.

The frequency stability shall be sufficient to ensure that the fundamental emission stays within the authorized frequency block. As this transceiver is considered "Hand carried, battery powered equipment" Section 2.1055(d)(2) applies. This requires that the lower voltage for frequency stability testing be specified by the manufacturer. This transceiver is specified to operate with an input voltage of between 3.50VDC and 4.30VDC, with a nominal voltage of 3.90DC. Operation above or below these voltage limits is prohibited by transceiver software in order to prevent improper operation as well as to protect components from overstress. These voltages represent a tolerance of -10 % and +12.5 %. For the purposes of measuring frequency stability these voltage limits are to be used.

For equipment powered by primary supply voltage

According to the JTC standard the frequency stability of the carrier shall be accurate to within 0.1 ppm of the received frequency from the base station. This accuracy is sufficient to meet Sec. 24.235, Frequency Stability. The frequency stability shall be sufficient to ensure that the fundamental emission stays within the authorized frequency block. For this EUT section 2.1055(d)(1) applies. This requires varying primary supply voltage from 85 to 115 percent of the nominal value for other than hand carried battery equipment.

TEST RESULTS

GSM850					
DC Power	Temperature (°C)	Frequency error(Hz)	Frequency error(ppm)	Limit (ppm)	Verdict
3.50	25	30	0.036	0.10	PASS
3.90	25	-29	0.035	0.10	PASS
4.30	25	-17	0.020	0.10	PASS
3.90	-30	-24	0.029	0.10	PASS
3.90	-20	21	0.025	0.10	PASS
3.90	-10	-21	0.025	0.10	PASS
3.90	0	-20	0.024	0.10	PASS
3.90	10	-24	0.028	0.10	PASS
3.90	20	-28	0.033	0.10	PASS
3.90	30	-27	0.032	0.10	PASS
3.90	40	-18	0.022	0.10	PASS
3.90	50	-17	0.029	0.10	PASS

PCS1900					
DC Power	Temperature (°C)	Frequency error(Hz)	Frequency error(ppm)	Limit (ppm)	Verdict
3.50	20	-40	0.021	0.10	PASS
3.90	20	-59	0.027	0.10	PASS
4.30	20	-40	0.021	0.10	PASS
3.90	-30	-37	0.020	0.10	PASS
3.90	-20	-45	0.024	0.10	PASS
3.90	-10	-47	0.025	0.10	PASS
3.90	0	-38	0.020	0.10	PASS
3.90	10	-38	0.020	0.10	PASS
3.90	20	-45	0.024	0.10	PASS
3.90	30	-48	0.026	0.10	PASS
3.90	40	-31	0.016	0.10	PASS
3.90	50	-37	0.020	0.10	PASS

5. Test Setup Photos of the EUT

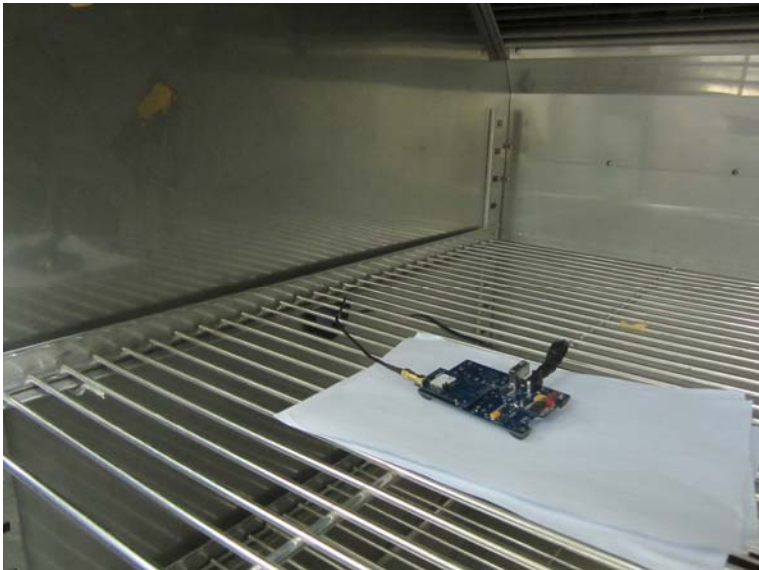
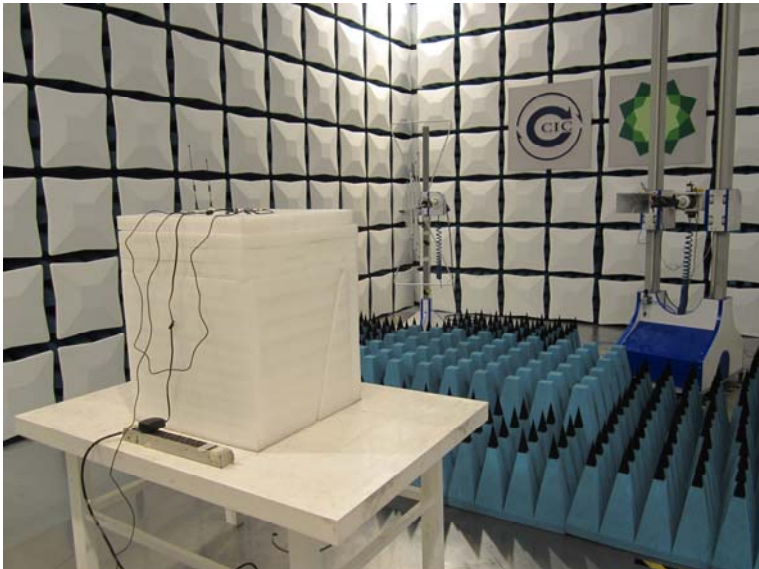



6. External and Internal Photos of the EUT

External photos of the EUT

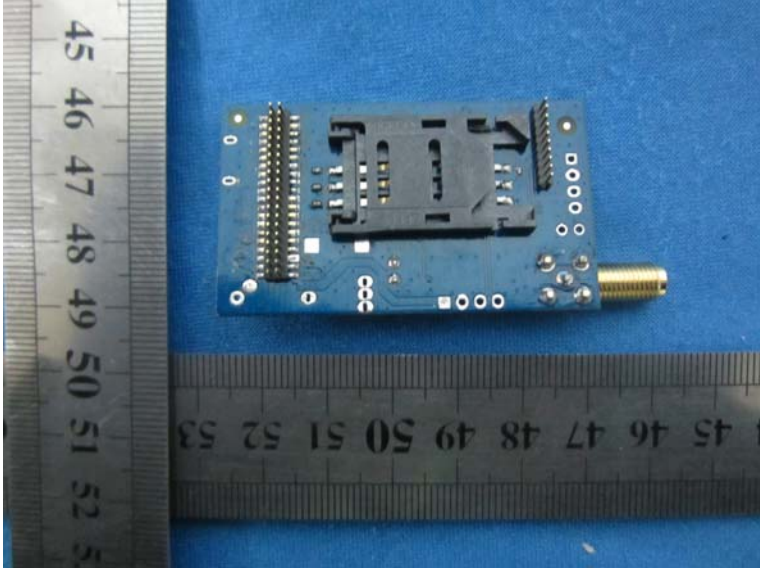
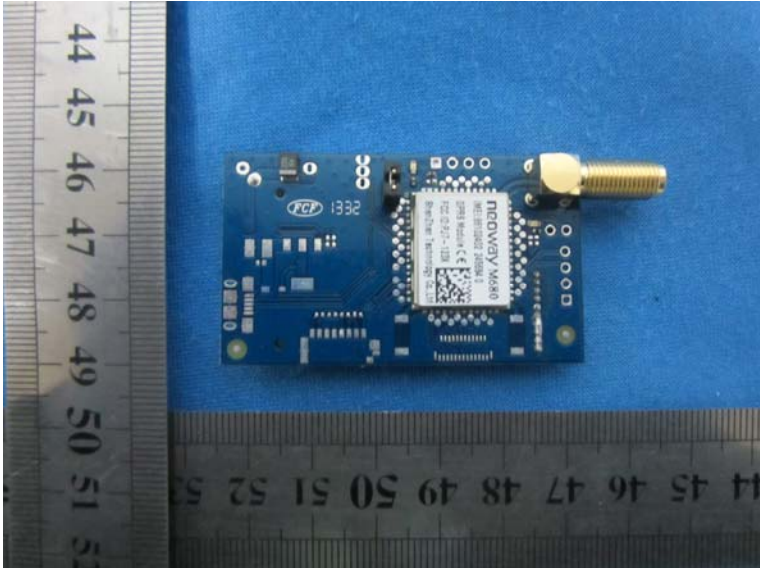

Internal photos of the EUT

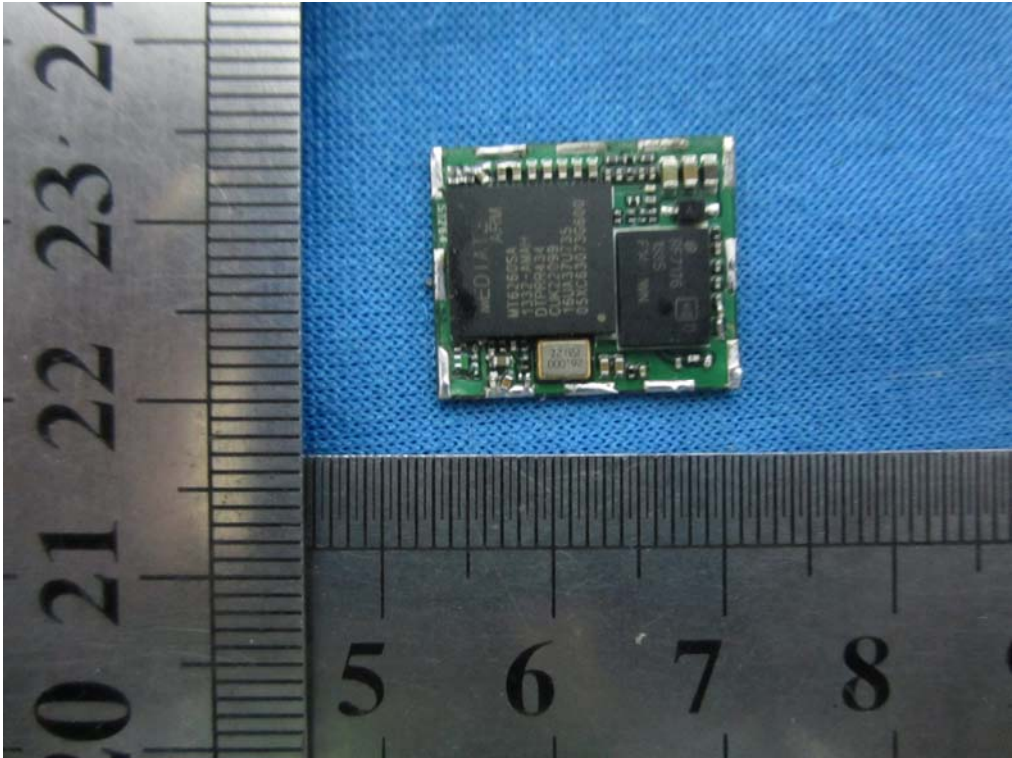
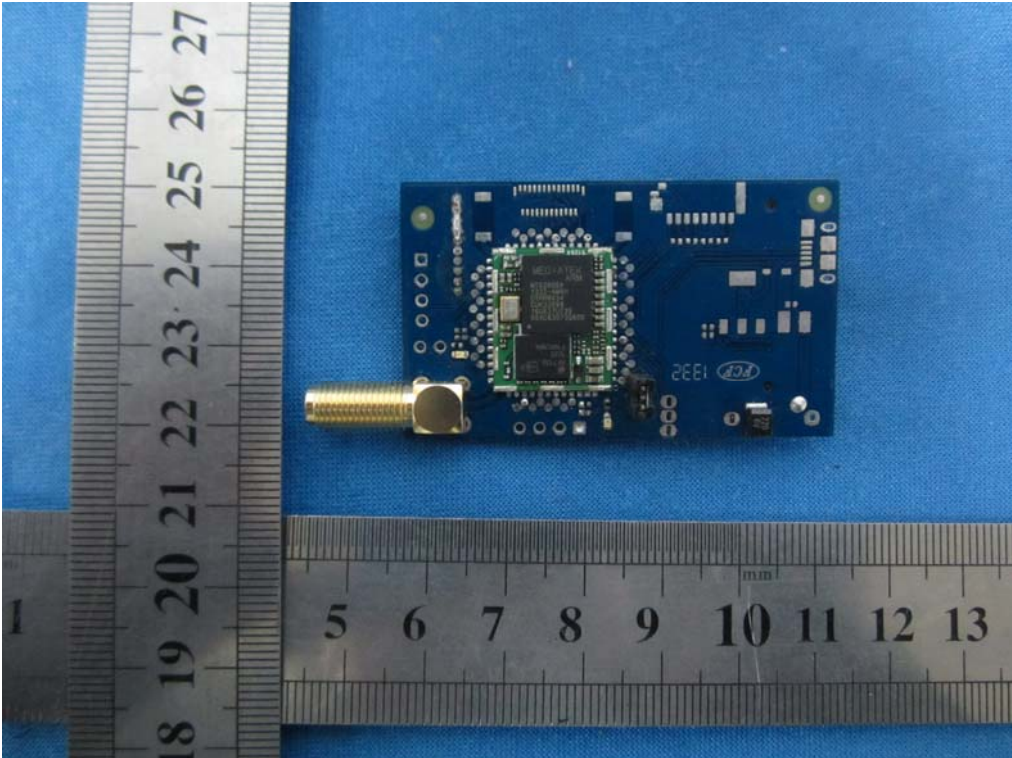

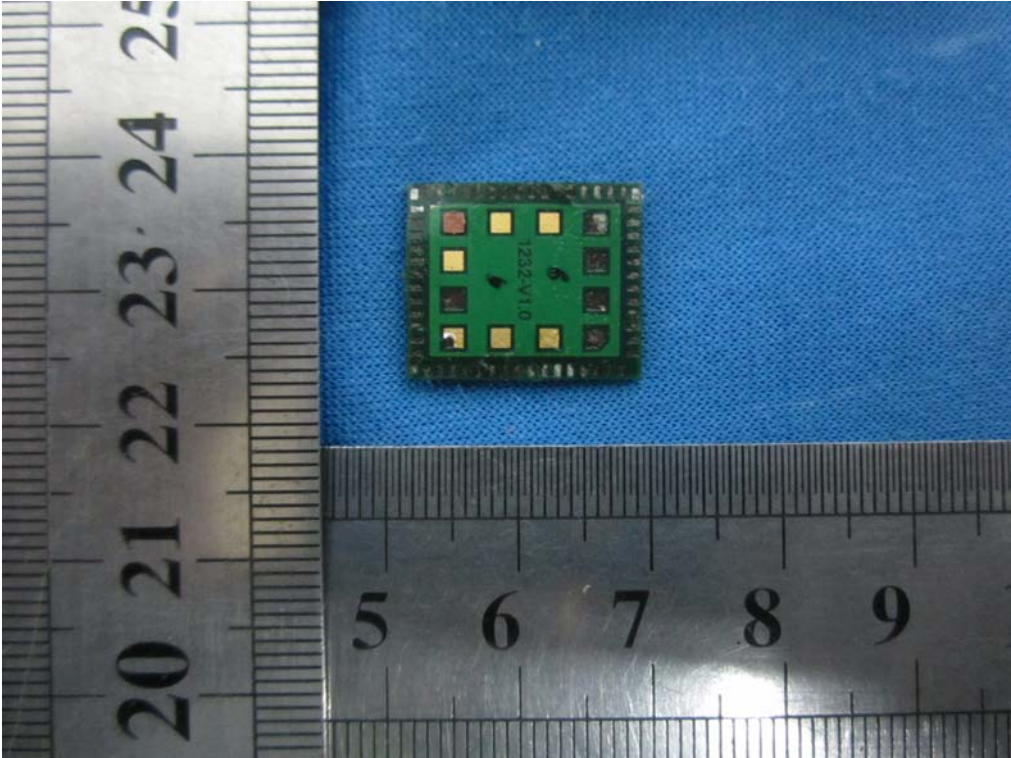

.....End of Report.....