



Raymarine Limited

2kW and 4kW Radome Radars

FCC ID: PJ5MTX2-S3 & PJ5MTX4-S3

Technical Description

Note: This Technical Description covers both the 2kW, 18" Radome Scanner Unit and the 4kW, 24" Radome Scanner Unit.

This page has been left intentionally blank

Technical Description

2kW and 4 kW Radome Scanner Units

1. Overview

Scanner configuration

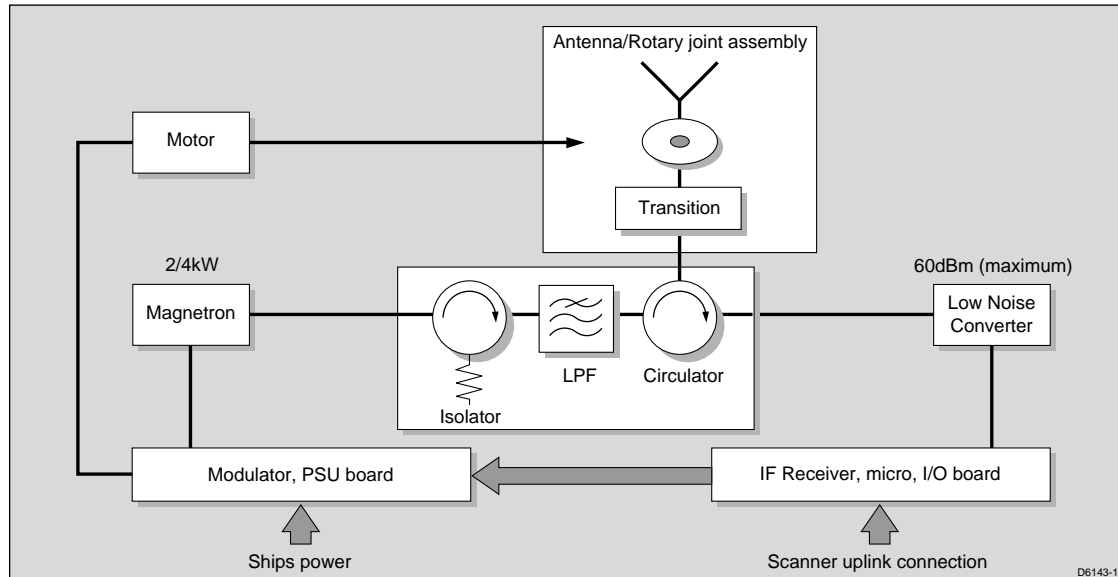

Figure 1: Scanner Block Diagram

The following system comprises the functional blocks as shown in the above diagram. The basis of operation is described below.

The **Modulator, PSU board** generates a high voltage pulse of between 75ns and 1.0 μ s duration dependant upon the range setting and the corresponding IF/Video filter control lines. This pulse begins on the rising edge of a negative going trigger at a pulse repetition frequency (PRF) also defined by the range setting. The resulting pulse is delivered to the **magnetron**, which converts the energy into an RF pulse at a frequency of 9.41 GHz (nominal).

The **Modulator, PSU board** also provides all supply requirements.

The RF pulse is routed to an **antenna** via a 3-port **circulator** combined with an **isolator** and **LPF (IFC)**, which propagates microwave energy in only one direction and thereby provides isolation between the transmit source and the **low noise converter**. A **rotary joint** is used to maintain continuity between a waveguide output from the **circulator** and a microstrip input to the **antenna**. This is achieved via transitions into, and back-out of, a section of coaxial line, which is configured with a 'split' perpendicular to the axis of rotation. The energy is then radiated by the antenna with a narrow azimuth beam shape (5.2° for the 18" antenna and 3.9° for the 24" antenna). The elevation beam width is maintained at approximately 25° in order to illuminate targets during pitch and roll of the transmitting vessel.

Echoes are returned due to reflections from potential targets such as boats, buoys, land, etc. and in the form of clutter from sea, rain, etc.

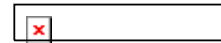

The returned energy is collected by the same **antenna** used to transmit the original pulse and is routed through the **IFC** to the **low noise converter (LNC)**. These comparatively low level signals are amplified by a low noise transistor in order to maintain signal/noise performance and are mixed down to an IF frequency of 60MHz (nominal) for further amplification and subsequent detection.

The **IF receiver board** provides further low noise amplification and adjustable gain to maximise the dynamic range (dynamic attenuation control) in the presence of clutter, target and range variations.

The IF board also includes a logarithmic detection stage with approximately 50dB dynamic range, which provides a compressed signal output in terms of dB input power versus output Voltage level.

Various filtering stages are also employed in the **IF Receiver board** to provide optimum signal/noise characteristics for the detected pulse and to provide some immunity against the bulk effects of rain.

The IF Receiver also provides the interface for the up-link commands to the scanner, including clutter and gain selection, stepper motor control and display synchronisation pulse generation.

Receiver configuration (LNC/IF)

The basic configuration of the microwave and IF receiver circuitry is as follows:

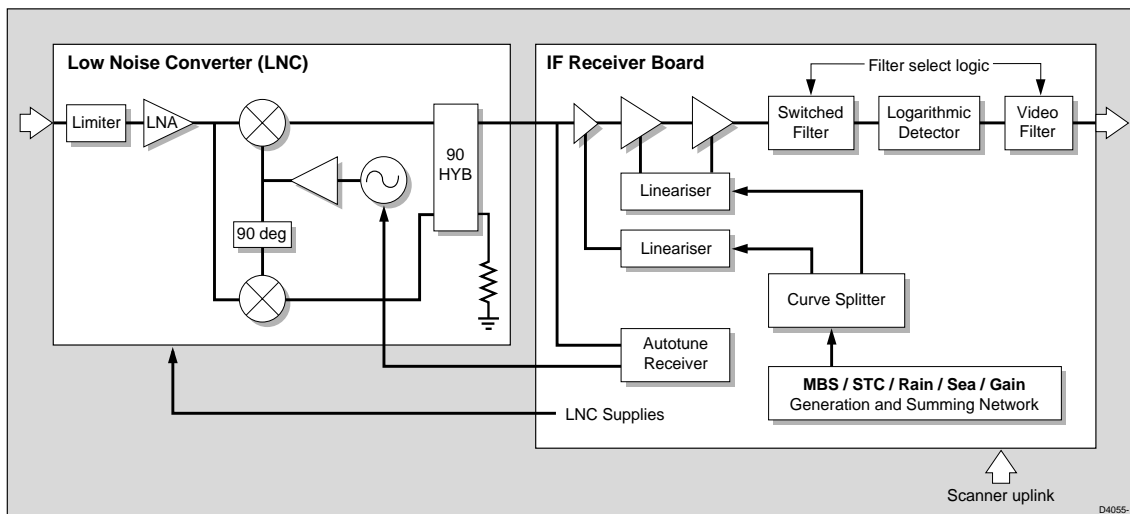
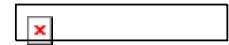

Figure 2: Receiver Configuration (LNC/IF)

Low Noise Converter/Limiter (LNC)

The primary function of the LNC is to provide low noise amplification of the low-level signal returns and mixing to an IF frequency of 60MHz nominal.

The low noise amplification is provided by a single low noise FET, with bias conditions, and associated matching set to minimise noise figure and maximise gain and compression levels. Maximum gain is required so as to minimise the noise figure contribution from subsequent stages. The mixing function is carried out in an image reject mixer configuration which



reduces image noise by 20dB nominal in order to minimise the degradation in overall noise figure.

Protection is provided in the form of three limiter diodes, which are configured to become forward biased in the presence of increasing RF power.

Note: *There are no user / dealer serviceable parts within the LNC due to its high frequency of operation.*

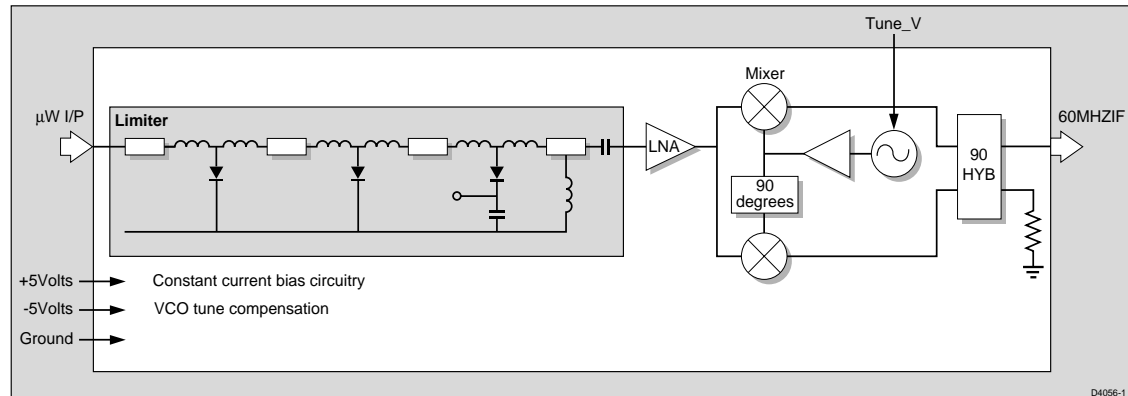

Figure 3: LNC Configuration

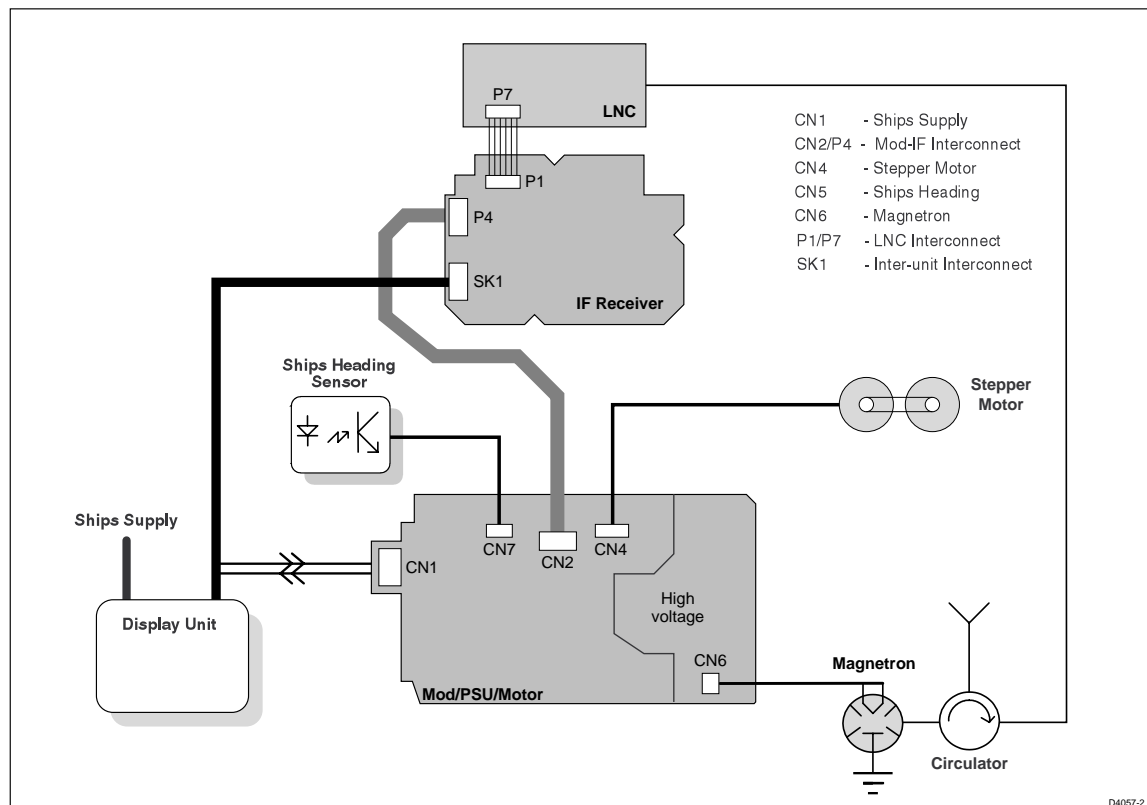
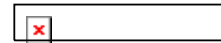

Figure 4: Scanner Interfaces

2. Modulator/PSU – Interface Description

The interfaces to the Modulator/PSU are shown in Figure 4 and the individual signal functions are described below:



Ships Supply Power Input (CN1)

Ref.	Signal Name	Type	State	Function
CN1-5 CN1-6	+V_SHIP	Power input	-	Ship's power I/P
CN1-1 CN1-2	-V_SHIP	Power input	-	Ship's power return

Modulator Control/Status (CN2)

Ref.	Signal Name	Type	State	Function
CN2-18	RADAR_TX_EN	Logic input	1 0 (default)	Enable modulator(magnetron) pulses Disable modulator, regardless of activity on PRI_PLS
CN2-9	PW0	Logic input	PW0 PW 1	Select course modulator pulse widths as follows:
CN2-11	PW1	Logic input	0 1 1 0 0 1 1 1	Short pulse ranges Medium pulse ranges Long pulse ranges Very long pulse ranges
CN2-16	PW_ADJUST	Analogue input	0-5.0V	Analogue voltage adjusts fine transmit pulse width
CN2-13	PTX_ADJUST	Analogue input	0-5.0V	Analogue voltage adjusts modulator transmit power
CN2-8	PRI_PLS	Logic input	Clock	10µs +/-0.5µs low. Rising edge triggers modulator pulse. PRF will be varied according to pulse width. See Figure 5 and Table 1 in Section 2.3.
CN2-3	HEATER_OK	Logic output	1 0	Indicates magnetron heater is connected and is drawing correct current. Magnetron heater faulty, or magnetron disconnected.
CN2-17	MOD_ISENS_E	Analogue input	0-5.0V	Indicates peak magnitude of magnetron anode current and thus indicates approximate peak RF power output. See Section 3.6 and Table 1 in Section 2.3.
CN2-19	REMOTE_SW+	Analogue input	0V	Indicates coms. from display to scanner present.
CN2-20	REMOTE_SW-		+Vship	Coms. not present.

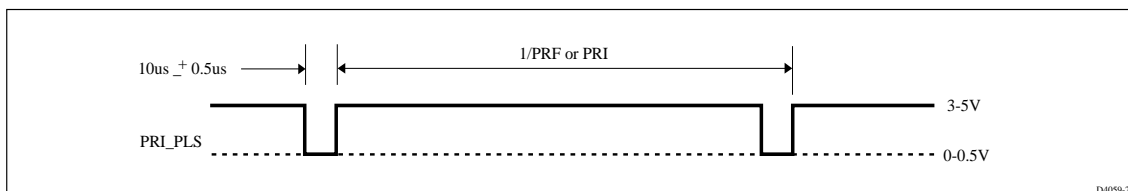

Figure 5: Modulator clock format, PRI_PLS

Motor Control

Ref.	Signal Name	Type	State	Function
CN2-12	MOTOR_EN_N	Logic input	0	Enable motor



			1	Disable motor
CN2-10	STEP_IO	Logic input/output	Clock	<p>For stepper motor build standard, input is 181Hz 50% duty cycle, which determines stepper motor speed.</p> <p>For all build standards this line acts to identify the type of build standard in conjunction with MOTOR_EN_N as follows:</p> <p style="padding-left: 40px;">MOTOR_EN_N = 1: Motor off. STEP_IO = 1: Stepper motor build standard</p>

Ship's Heading Interface

Ref.	Signal Name	Type	State	Function
CN2-15	SHP_IN	Logic output	Clock	Negative going edge indicates antenna position is at nominal zero azimuth. This corresponds to a point just before the antenna reaches the forward facing position.

Receiver Power Supply

Ref.	Signal Name	Type	State	Function
CN2-1	IF-5V	Power	-	-5V power rail to receiver
CN2-2	IF+5V	Power	-	+5V power rail to receiver
CN2-4	IF+26V	Power	-	+26V power rail to receiver
CN2-6	IF+12V	Power	-	+12V power rail to receiver
CN2-5	GND	Power	-	Isolated GND return from receiver power rails
CN2-7	GND			

Stepper Motor Interface

Ref.	Signal Name	Type	State	Function
CN4-6	STMO1	Analogue	-	Phase A2 switch
CN4-5	STMO2	Power	-	+12V motor
CN4-4	STMO3	Analogue	-	Phase A1 switch
CN4-3	STMO4	Analogue	-	Phase B1 switch
CN4-2	STMO5	Power	-	+12V motor
CN4-2	STMO6	Analogue	-	Phase B2 switch

Ship's Heading Sensor Opto-coupler Interface

Ref.	Signal Name	Type	State	Function
CN5-1	BZ	Analogue	-	Opto emitter connection
CN5-2	+5V	Power	-	+5V to opto LED anode and collector connection
CN5-3	SHGND	Power	-	Opto LED cathode GND connection
CN5-4	SHGND	Power	-	Cable screen connection

Magnetron Interface

Ref.	Signal Name	Type	State	Function
CN6-1	HEATER	Analogue output	-	Magnetron heater power and signal cathode connection
CN6-2	HEAT/CATH	Analogue output	-	Magnetron heater power return and signal connection.

Note: *The magnetron anode connection is made through the body of the device to the chassis GND.*

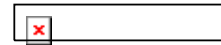

Service only, PSU ON Jumper

Ref.	Signal Name	Type	State	Function
JP600_1	REMOTE_S W+	Analogue input	–	This jumper is normally open.
JP600_2	0V	Power	0V	It maybe shorted by service personnel to enable fault finding of PCB with no coms. to IF PCB.

WARNING: The Mod/PSU PCB will have high voltages enabled when jumper is closed.

3. Modulator/PSU – Circuit Description

Design Overview

The Modulator/PSU PCB integrates the modulator, power supply and motor drive functions of the radar scanner assembly.

The power supply section provides regulated power to all functions within the scanner unit, except the motor, which is driven directly off the input supply. The modulator drives the magnetron when enabled and triggered from a simple logic input with one of eight pre-set pulse widths selected by the IF receiver module. The Motor Controller drives the stepper motor which rotates the antenna.

The Figure 6 below shows an overall block diagram of the Mod/PSU PCB showing the principal circuit blocks.

Circuit Description

EMC Filter

The EMC filter section comprises of series ferrites, common mode inductors and associated filter capacitances to minimise EMC problems with other electronic equipment.

Over Voltage Protection

A varistor, VR1, protects the unit from over voltage surges.

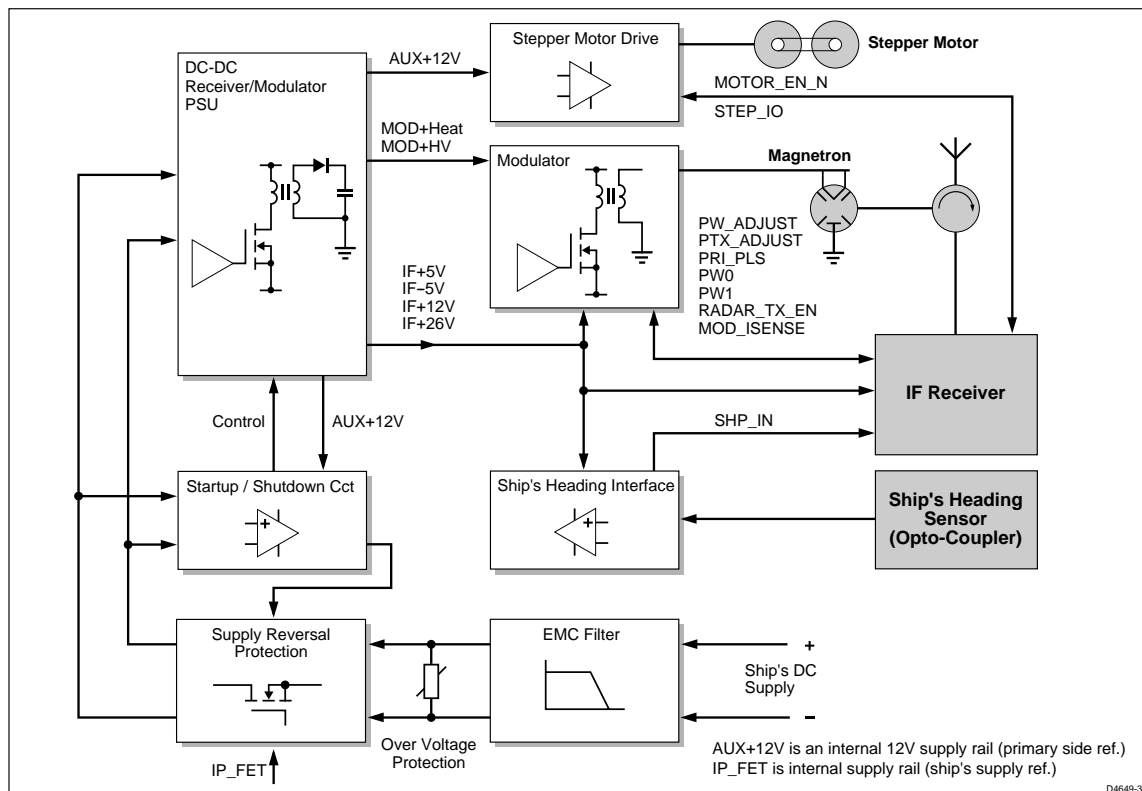
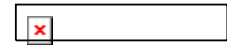

Figure 6: Modulator/PSU Overview

Supply Reversal Protection

The scanner is protected from inadvertent reversal of the ships supply by FET, Q1. This FET will not connect the ships supply to the board as long as its polarity is reversed. When the ships supply is connected correctly the FET body diode will conduct and start the internal charge pump formed by D33, C146, etc. which will drive the IP_FET supply to approximately 12V greater than the ships supply voltage and turn ON the FET.

DC-DC and Start/Shutdown Circuit

WARNING:

The Power Supply circuit contains very high voltages and energy levels, care should be exercised in all maintenance activities in this area. Only those items that appear on the Raymarine spares list may be replaced.

This switch mode power supply unit derives the low voltage supplies for the receiver, modulator, magnetron and motor drive assemblies. It is configured as a flyback converter whereby the ship's supply is switched at approximately 65kHz across the primary of transformer Tx1 by FET Q21. Pulse width modulation (PWM) control is by IC U8 which senses the voltage of an internal power rail, +5.5V, and drives the FET to maintain voltage regulation. Internal supplies, IP_FET, PWM+V, +HIGATE and +GATE have the ship's supply as their ground reference. All other output voltage rails are isolated from the ship's supply and therefore must be ground referenced to the secondary side when measured.

Note: *When fitted within the core assembly the secondary side ground reference is connected to the metal chassis.*

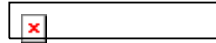

The high voltage supply, MOD+HV, is derived from a pair of series connected secondary windings. The IF+26V supply is derived from a charge pump comprising D21, Q23, etc.

The +GATE supply is referenced to TX1 primary side, and is derived from the primary flyback voltage. This supply is referenced to the positive supply input rail such that it remains approximately 15V greater than the input supply. From this rail the IP_FET and +HIGATE supplies are derived to drive the input polarity protection FET, Q1.

The scanner is protected from operation at inadequate ships supply voltages by the start/shutdown circuit comprising of Q27, etc. This circuit will shut the supply down if the ships supply falls below the minimum scanner operating voltage. This circuit also detects a fault condition if the secondary supplies are over voltage, via D39, OP3, etc. If this fault condition is detected the supply is shut down.

In both shutdown cases described above after a brief interval the supply will attempt to restart. If the fault condition is still present then a further shutdown occurs. Thus the supply will cycle in this manner at low frequency until the fault is cleared.



Scanner Operating Supply Voltage Range

Parameter	Units	Min.	Max.	Conditions
Operating voltage range	V	7.5	32.0	Measured at CN1
Minimum start-up voltage	V	10.0	–	Minimum V to start operating, measured at CN1
Reverse polarity leakage current	µA	0	+/- 100	DC
Maximum leakage current between isolated secondary GND and ship's supply	µA	0	+/-1	Measured with 32.0V differential imposed between V_SHIP+ and isolated ground

Output Specification DC-DC1

Parameter	Units	Min.	Nom	Max.	Conditions
IF -5V output	V	-5.6	-6.0	-6.4	–
IF -5V load	mA	0		125	Load will be reduced to minimum during standby state of IF receiver
IF +5V output voltage	V	4.8	5.0	5.4	–
IF +5V load	mA	50		350	Load will be reduced to minimum during standby state of IF receiver
IF +12V output voltage	V	11.2	12.0	12.4	–
IF +12V load	mA	0		300	Load will be reduced to minimum during standby state of IF receiver
IF +26V output voltage	V	25.0	27.0	29.0	–
IF +26V load	mA	1		2	–

Modulator

WARNING:

The modulator circuit contains very high voltages and energy levels, care should be exercised in all maintenance activities in this area. Only those items that appear on the Raymarine spares list may be replaced.

The modulator's function is to drive the magnetron in order to generate a transmit pulse at approximately 9.4GHz to the antenna. The modulator is required to generate eight different pulse widths as selected by external logic control lines, PW0, PW1 and analogue control, PW_ADJUST. The PW0 and PW1 logic controls select one of four possible 'coarse' pulse width selection ranges, whilst fine adjustment within each coarse range setting is provided by the analogue voltage setting of PW_ADJUST. Each unit is calibrated for pulse width by automated production test equipment, and the calibration data is saved within the non-volatile memory within the IF controller.

Modulator output power is trimmed by production test equipment by adjustment of the analogue voltage setting of PTX_ADJUST.

The modulator is fired when triggered by the rising edge of the PRI_PLS logic level control signal from the micro controller. In addition a further control line RADAR_TX_EN is used to over-ride PRI_PLS and disable transmission when held low (the default state is transmit disabled if the IF controller is disconnected). Output sense lines, HEATER_OK and MOD_ISENSE, sense the magnetron heater and transmit currents, indicating correct operation to the external micro controller.

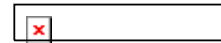

The modulator comprises a high voltage pulse transformer, TX3 and a switching FET Q41 together with control and pulse shaping circuitry. In operation the control circuitry selects one of eight pulse widths, which drives the FET gate via IC U13. As the FET turns on it switches the high voltage supply, MOD+HV, across the very low impedance of the pulse transformer primary. The current rapidly rises in the FET and its series source resistor until the FET begins to pinch-off thus holding the current at a constant level. The resulting primary voltage pulse causes an associated secondary pulse stepped-up by the transformer turns ratio to several kV. When the secondary voltage reaches the magnetron switch-on threshold it will ‘fire’ generating a burst of microwave power at several kW and at a frequency of 9.41GHz.

Table 1: Range, Pulse width and PRF

Range (nm) (X = Pulse Expand ON)	Nominal PW (ns)	PRF (kHz)		PW1 state	PW0 state	Normal magnetron current reading	Course PW
		2kW	4kW				
1/8, 1/4	75	3.0	3.0	0	0	15 – 45	SP range
1/8X, 1/4X, 1/2	100	3.0	3.0	0	0	30 – 65	SP range
1/2X, 3/4	150	3.0	3.0	0	1	60 – 100	MP range
3/4X	250	2.5	3.0	0	1	80 – 135	MP range
				1	0		LP range
1 1/2	350	1.8	2.0	1	0	85 – 145	LP range
1 1/2X, 3	450	1.4	1.5	1	0	80 – 145	LP range
3X	600	1.0	1.3	1	1	80 – 140	VLP range
6, or greater	1000	0.74	0.74	1	1	60 – 125	VLP range

Two circuit monitor the performance of the modulator/magnetron to provide diagnostic information for servicing, which may be read in the diagnostics menu at the display unit:

- Comparator U14D senses the correct flow of magnetron heater current and provides an output, HEATER_OK which is normally a logic high when the magnetron is connected and drawing at least the minimum specified current.
- Peak detector D60, etc detects the peak pulsed magnetron current flow and derives the signal MOD_ISENSE which gives an indication of the transmit power. This circuit may be used with some confidence to diagnose correct modulator/magnetron operation. The reading may be found in the display diagnostics menu (see Section 3.3). The value will change with selected range setting. See Section 3.6, Diagnostics Menu and Table 1 below, for details.

Modulator Clock, PRI_PLS

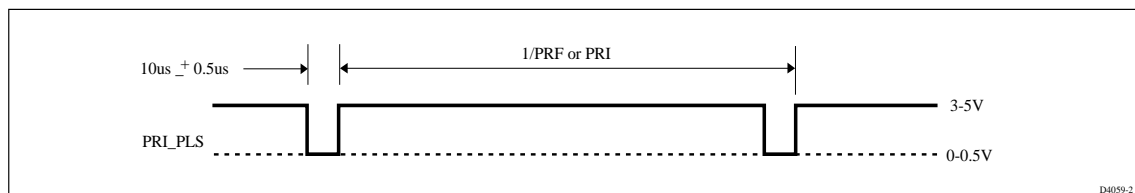

Figure 7: Modulator Clock, PRI_PLS



Ships Heading Sensor

The ships heading sensor is used to indicate the antenna alignment. It provides one output pulse per antenna revolution. This information is utilised by the IF receiver to synchronise the radar output to the ships heading.

A slotted optical transducer is interrupted by the principal gear of the antenna rotary joint assembly. This results in a negative going pulse at CN5-1. This pulse is variable in amplitude with ambient lighting level and device tolerance. This pulse is conditioned by the interface formed by U23 and reappears as SHP_IN at CN2-15 as a negative going pulse of approximately 5V amplitude. If the antenna is rotating normally this pulse will have a repetition rate of approximately 2.5 seconds.

Stepper Motor Controller

A stepper motor is used to rotate the antenna of all radome radar units. The stepper motor is a 2-phase unipolar type, driving the antenna main gear by means of a flexible belt. The stepper motor is mounted to the main casting, which provides heat sinking for the motor. The motor frequency is determined by the frequency of the external drive clock, STEP_IO which originates at the IF board micro controller and is nominally 181Hz. The motor drive interface comprises U24 and associated circuitry. An enable signal, MOTOR_EN_N switches the motor drive on when at logic 0. The motor is connected at CN4. Pins 2 and 5 are the raw 12V motor supply (only active when the high voltage PSU, DC-DC2, is enabled). Pins 1, 3, 4 and 6 carry the motor winding drive signals. If any winding drive signal becomes disconnected the motor will normally fail to rotate and will vibrate instead. If the magnetron heater at CN6 is disconnected the motor may rotate with reduced torque.

4. IF Receiver PCB – Interface Description

The interfaces to the IF Receiver are shown in Figure 4, Section 2.1. The individual signal functions are described below:

Connectors

Connector	Function	Type
SK1	Display connector for serial communications, video and synchronisation timing signals	8-way Molex C-grid socket
P1	LNC Connector	20-way SAMTEC CLH-110-F-D-DV-P (7 pins only used)
P4	Mod/PSU – IF interconnect	20-way Picoflex ribbon connector

Display Connector (SK1)

Ref.	Signal Name	Type	State	Function
SK1-1	AZ_SHP_OU TB	Clock, differential pair output	Normally high, low going clock	A differential output pair providing azimuth pulses to synchronise antenna position with display (10µ duration at approximately 820 Hz). The SHP

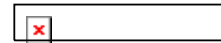

SK1-2	AZ_SHP_OUT T		Normally low, high going clock 0 – 5.0V	(Ship's Heading Position) pulse is superimposed on the signal once per antenna revolution (30µ pulse every 2.5 secs).
Continued				
Ref.	Signal Name	Type	State	Function
SK1-3	SER_IOB	Digital comms.	2.2V nominal DC bias	An RS485 bi-directional serial communications link operating at 19.2 kBaud. It provides control of the scanner operation and monitoring functions from the radar display.
SK1-4	SER_IO	Differential pair, bi-directional	2.8V nominal DC bias	
SK1-5	PRI_OUTB	Clock, differential pair output	Normally low, high going clock	A differential output pair providing PRI (Pulse Repetition Interval) pulses to synchronise the firing of the transmitter with the display video. Rate is according to range setting.
SK1-6	PRI_OUT		Normally high, low going clock 0 – 5.0V	
SK1-7	VIDEO_GND	Analogue video output	AC coupled 1.75V max.	The raw radar video signal from the scanner.
SK1-8	VIDEO		peak signal into 75 ohms	

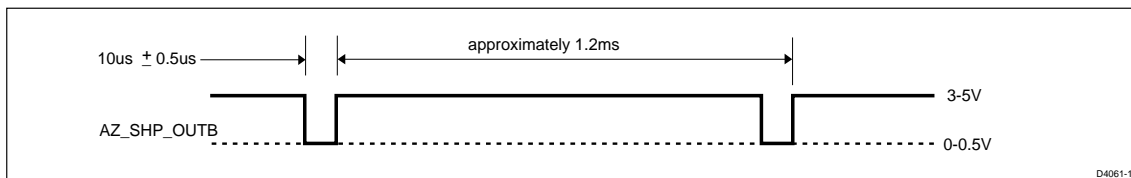

Figure 8: AZ_SHP_OUTB/AZIM_DNEG

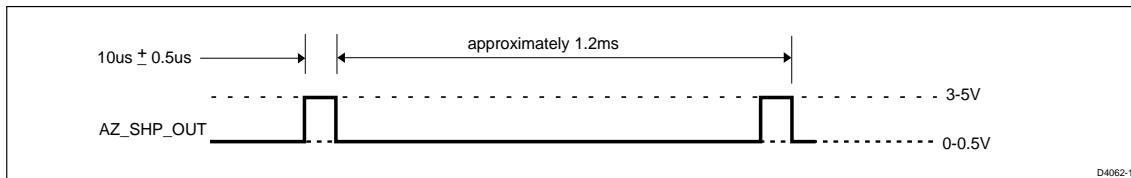

Figure 9: AZ_SHP_OUT/AZIM_DPOS

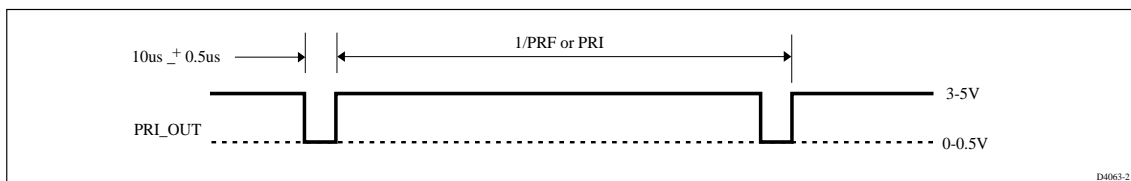

Figure 10: PRI_OUT/PRI_DPOS

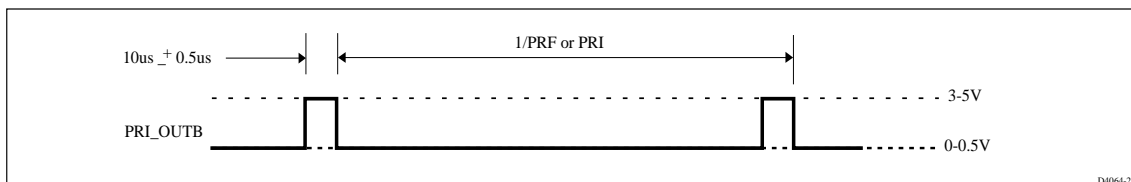

Figure 11: PRI_OUTB/PRI_DNEG



LNC Connector (P1)

Ref.	Signal Name	Type	State	Function
P1-1	GND	60 MHz IF radar received signal input	-	The down-converter received radar signal from the LNC at 60 MHz IF (Intermediate Frequency) carrier frequency
P1-2	60 MHz IF			
P1-3	Not connected	-	-	-
P1-4	RF_ATTENV	Analogue output control voltage	0 – 10V	-
P1-5	TUNE_V	Analogue output control voltage	4 – 24V	A control voltage that is applied to the LNC VCO (Voltage Control Oscillator) to maintain the tuning of the LNC output to 60 MHz.
P1-6	GND	Analogue output	0V	Analogue ground reference for the LNC supplies
P1-7	+5V	Analogue output (switchable)	0V in standby mode +5V in transmit mode	The 5V supply for the LNC. It is switched OFF in standby mode to save power.
P1-8	-5V	Analogue output	-5.9V	The -5.9V supply for the LNC

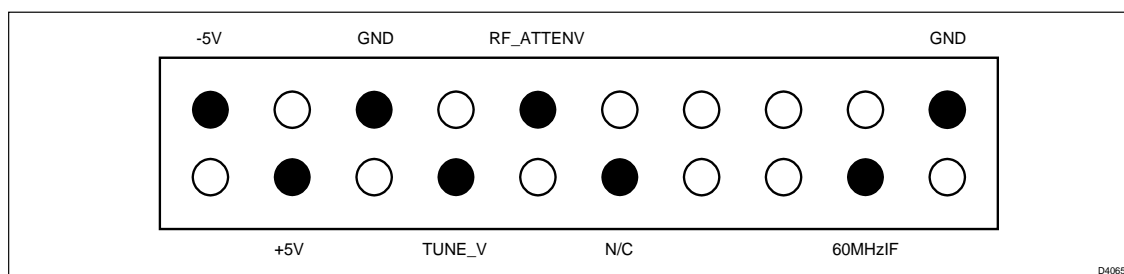

Figure 12: LNC Connector P1 connections as viewed from component side of board.

Mod/PSU – IF Interconnect (P4)

This connector P4 is pin to pin identical to CN2 connector on the MOD/PSU PCB. See MOD/PSU Interface, Section 2.2 for details.

5. IF Receiver – Circuit Description

Main Receiver

The prime function of the IF receiver is to provide low noise amplification and logarithmic detection of the 60 MHz IF (Intermediate Frequency) radar received signal, to give a video signal output suitable for displaying on the radar screen (after digital processing at the display).

The receiver provides low noise amplification, dynamic IF gain control (STC) and selectable IF bandwidths to optimise target detection for all ranges and for various sea and weather conditions. The following summarises the functions of the circuitry.

A low noise amplifier (AR1), is situated prior to an adjustable gain monolithic microwave integrated circuit (MMIC) amplifier stage (U9 and U10) in order to define the noise figure of

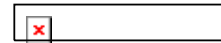

the system. This incorporates the relevant circuitry to provide fast gain control via the STC generator.

General amplification and attenuation control is also provided by the cascaded MMIC amplifiers U9 and U10 in conjunction with factory-tuned inductors (L4, L10 and L11) and capacitors to tailor the bandwidth characteristics of the circuit.

IF Bandwidth switching between 12MHz and 3MHz is configured to provide matched filtering for the shorter transmit pulses, which are automatically set when the Radar range is adjusted. Gain is increased accordingly to maintain a relatively constant noise power at the receiver output.

Switched video filters are used in conjunction with the 3 MHz IF filter to provide matched filtering for the 600ns and 1us pulses. These are 0.7 MHz and 0.5MHz respectively.

Remaining variations in noise power as a consequence of the different signal bandwidths (i.e. noise power is directly proportional to bandwidth) are adjusted in the display.

A ‘fast time constant’ circuit is used to provide a continuously variable high pass filter to provide some immunity against the bulk effects of rain.

Note: *The variable inductor coils L4, L10 and L11 are pre-set at the factory. They require specialist equipment for tuning and must not be adjusted by the service engineer.*

The PRI rates and video noise can be observed at the appropriate connectors (see interface section) for the different range settings as follows:

Radar Range Setting	IF BW	Video BW	Pulse width used	Video Noise Level
1/8, 1/4, 1/2, 3/4 nm	12 MHz	15 MHz	65, 250 ns	>500 mV pk-pk
1 1/2, 3 nm	3 MHz	15 MHz	350, 450 ns	>500 mV pk-pk
3 nm (target expanded)	3 MHz	0.7 MHz	600 ns	>250 mV pk-pk
6 nm to max. range	3 MHz	0.5 MHz	1 µs	>200 mV pk-pk

Autotune Receiver

The autotune receiver provides frequency selective peak detection of high level ‘main-bang’ transmitter pulses. This is achieved using a high impedance branch from the main receiver input with a transistor/diode based amplifier/detector circuit (Q31, Q32, D16, Q33 and Q37). The detection bandwidth of the autotune receiver is set at the factory using variable inductors L7, L8 and L9. The output of the receiver is buffered (U6A) and passed to the scanner microprocessor. A tuning algorithm is then performed at the display to set the difference frequency between the magnetron and VCO (Voltage Controlled Oscillator) to a fixed IF frequency of 60MHz using the TUNE_V control line P1-5. Both coarse and fine adjustments are provided by the microprocessor to allow for initial setting and subsequent fine tuning.

Note: *The variable inductor coils L7, L8 and L9 are pre-set at the factory. They require specialist equipment for tuning and must not be adjusted by the service engineer.*

STC/Main Bang Suppression (MBS)

The STC circuitry consists of a logarithmic function generator split into four outputs and multiplied by 4, 5.5 and 2 to generate the R4, sea clutter and rain curves respectively.

These curves are offset as requested via processor/operator demands and then combined to provide an output equal to the greatest of the inputs. A curve splitter and linearisation circuits are used to match the output control levels to the characteristics of each attenuator.

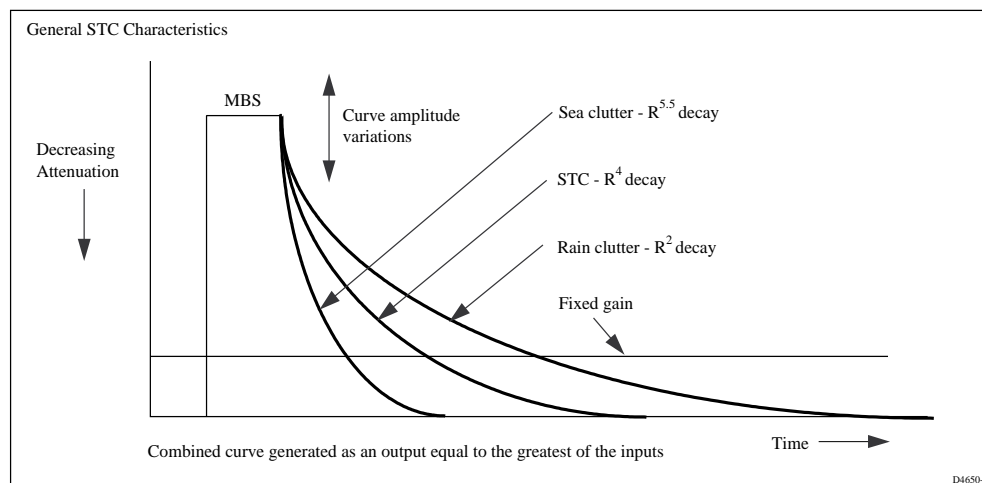

Figure 13: General STC Characteristics

Main bang suppression (MBS) amplitude and duration controls are configured so as to override these STC controls.

For low values of attenuation, the attenuation is applied to the monolithic amplifiers in order to preserve system noise figure. At higher values of attenuation, the attenuation is divided between the IF pin attenuator (D17) used to control the first IF amplifier stage, and the monolithic amplifiers.

Microcontroller

The microcontroller subsystem, using an NEC 78054 device, is integrated onto the IF receiver board and provides the following functions:

- Generates analogue control voltages via a multi-channel Digital to Analogue Connector (DAC) for all user and automated scanner adjustments
- Reads the tune indicator input and adjusts tune control voltage as necessary.
- Controls modulator pulse width selection, by selecting PW0 and PW1 control lines (coarse PW adjustment) and then adjusting the analogue output (fine PW adjustment). See Warning below.
- Generates Azimuth pulses for display synchronisation.
- Generates the PRI (Pulse Repetition Interval) pulses to fire the magnetron, start the STC cycle and synchronise the display.
- Buffers the Ships Heading Pulse from the MOD/PSU PCB for synchronising the display.
- Communicates with the display via a serial interface.



Initial Scanner set up (EEPROM stored values)

The scanner has non volatile storage (EEPROM U18) for the following items:

- Optimum VCO coarse and fine tune settings.
- Calibrated values for setting each of the 8 transmit pulse widths. See **Warning** below.
- Default values for the Auto Gain function for each pulse width (used when GST is selected for the display).
- MBS duration and amplitude for each pulse length.
- Range Zero Offset (adjusted by Display Timing function in Advanced Settings Menu) for each filter setting.
- Azimuth Zero Offset (adjusted by Bearing Alignment function in Radar Set Up Menu)
- STC Pre-set Max – a pre-set level of R4 clutter curve is set to equalise close target returns
- Scanner Size - storage of the antenna size fitted to the scanner - used to set maximum range for the display.
- Modulator Power - The power of the modulator in kW - also used to set maximum range for Display.

WARNING:

The IF PCBs for the 2kW and 4kW scanners are not interchangeable, as the stored pulse width settings are different.

The above stored parameters each have a factory set and used working location. These values are set at the factory and are optimised for each individual scanner unit to provide optimum performance and a good starting value when the radar system is first operated. However, the VCO tuning, Range Zero Offset and Azimuth Zero Offset used working values are adjustable from the display during Radar operation.

Due to temperature variations affecting the LNC, the VCO tuning values are adjusted by the display when Auto mode is selected to give optimum tuning. The present optimum value is stored when a range change (i.e. transmit pulse length change) is made, so that when the range is selected again, the auto-tune function is at a better starting point. Normally this adjustment is made just to the fine tune value for each pulse length. Occasionally, a change in coarse tune may be necessary. If tuning problems occur, the Tune Pre-set function in the Advanced Settings Menu provides a manual way of adjusting the coarse tune used working value.

The Range Zero Offset is adjusted manually from the display Advanced Settings Menu (Display Timing) as part of the normal Radar installation procedure. If the inter-unit cable is kept to the supplied length the Display Timing should not normally need adjusting.

STC pre-set maximum is set at the factory, however the STC pre-set value can also be changed via the Advanced Settings Menu.

When a Factory Reset is performed, the scanner copies the factory set-values back into the used working locations of the EEprom, so the scanner and display revert to the set-up when they left the factory. To perform a Factory Reset press MENU, select SYSTEM SET UP, then press and hold MENU for 5 second countdown.



The EEprom also stores the scanner Build Standard information that is accessible through the Diagnostics Menu, see Chapter 3, Fault Finding.

6. Antenna/Rotary Joint assembly

The scanners use either 18" or 24" microstrip Patch arrays. The primary specification for the antenna/rotary joint assembly is as follows:

Parameter	18" Radome	24" Radome
Operating frequency	9.410 GHz	9.410 GHz
Azimuth beam angle	5.2°	3.9°
Elevation beam angle	<28°	<28°
Antenna gain across bandwidth	22.3 dB nominal	22.9 dB nominal
Return loss	>15.0 dB	>15.0 dB
Sidelobe levels	>-22 dBc	> -22 dBc

* Bandwidth requirements are defined by the magnetron uncertainty

7. Scanner Display Connection

The scanner/display interface is a universal link between any display and any scanner. It consists of a single, multi-core cable with a single moulded plug at the display and multiple connections at the scanner:

- Video, Serial bus, PRI, Azimuth/Ships heading pulse (connected at SK1).
- Power (connected at CN1).

A moulded plug at the display provides the necessary sealing against the environment, whereas at the scanner this is provided with a compression cable gland, a push-fit connector for signals (8-way) and sprung-loaded connectors for power (2 or 4 way)

The cable consists of the following cores:

1. 75 ohm coaxial cable carrying the 1.75V peak to peak video signal from the scanner (pins 7 and 8).
2. Twisted pair cable (purple/grey) carrying the 5V differential azimuth and ships heading reset synchronising signal from the scanner (pins 1 and 2).
3. Twisted pair cable (yellow/orange) carrying 5V differential PRI pulse synchronising signal from the scanner (pins 5 and 6).
4. Twisted pair cable (green/blue) carrying 5V differential, bi-directional serial communications signal (RS485) between scanner and display (pins 3 and 4).
5. DC ships power to scanner (2 or 4 cores).