



Raymarine Limited

8-Pulse Width Radome Radars

FCC ID: PJ5MTX2-8P & PJ5MTX4-8P

Schematics

Index

Scanner Interconnect	4437-011	Sht. 1
Modulator/PSU	4437-002	
Modulator/PSU (Top Level)		Sht. 1
Power I/P Filter		Sht. 2
Main PSU		Sht. 3
Modulator		Sht. 4
Ships Heading Interface		Sht. 5
Stepper Motor		Sht. 6

Low Noise Converter (LNC)	4346-028	Sht. 1
IF Receiver	4437-004	
IF Receiver (Top Level)		Sht. 1
IF Strips		Sht. 2
IF Log Det/Video		Sht. 3
Scanner Micro		Sht. 4
Control Interface		Sht. 5
STC Generator		Sht. 6

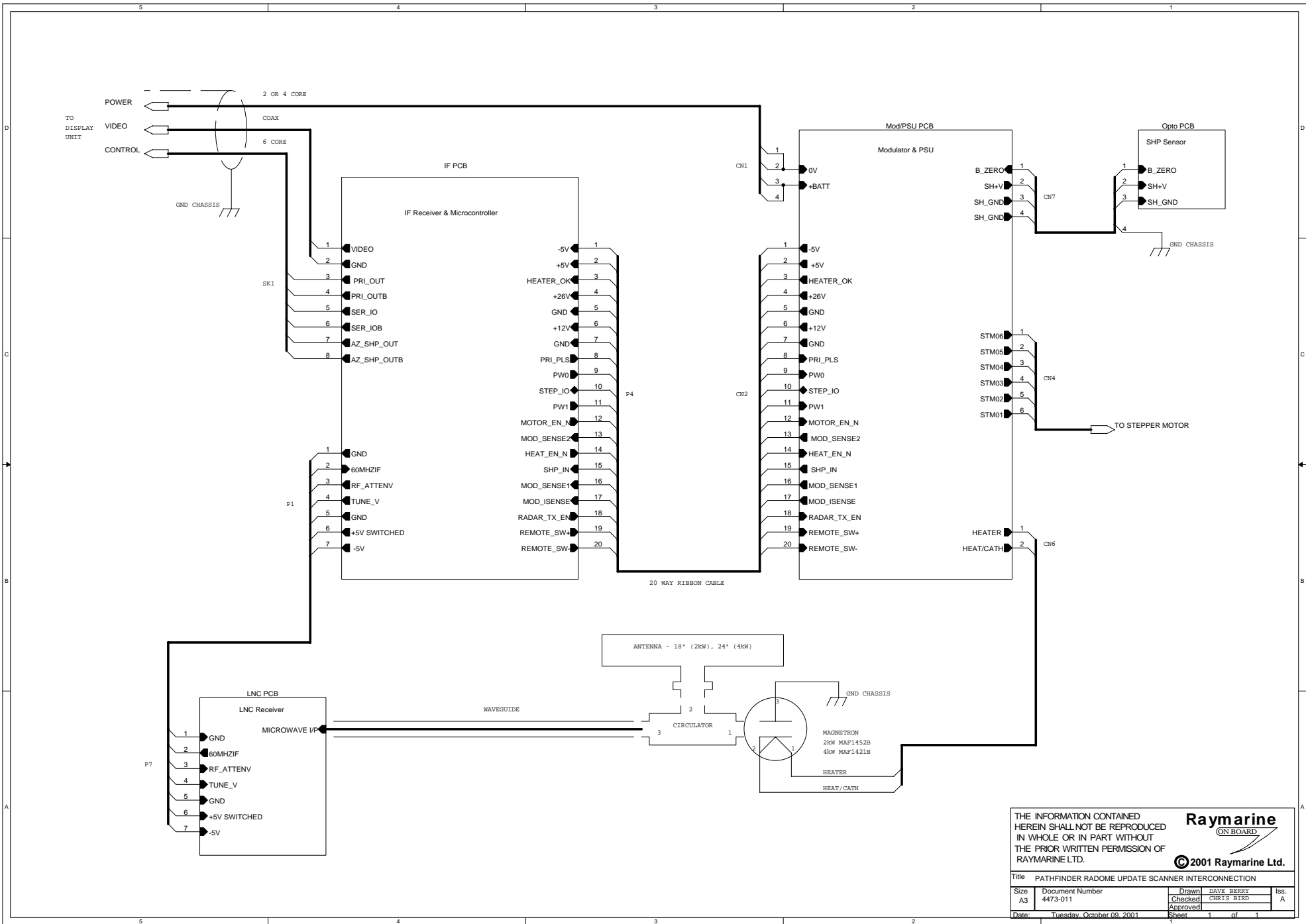

THE INFORMATION CONTAINED
HEREIN SHALL NOT BE REPRODUCED
IN WHOLE OR IN PART WITHOUT
THE PRIOR WRITTEN PERMISSION OF
RAYMARINE LTD.

Raymarine
ON BOARD

© 2001 Raymarine Ltd.

Title: PATHFINDER RADOME UPDATE SCANNER INTERCONNECTION			
Size: A3	Document Number: 4473-011	Drawn: DAVE BERRY	Iss: A
		Checked: CHRIS BIRD	
		Approved:	
Date: Tuesday, October 09, 2001		Sheet: 1	of: 1

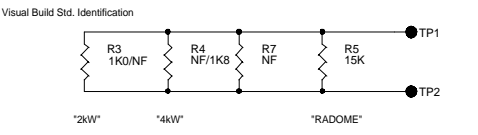
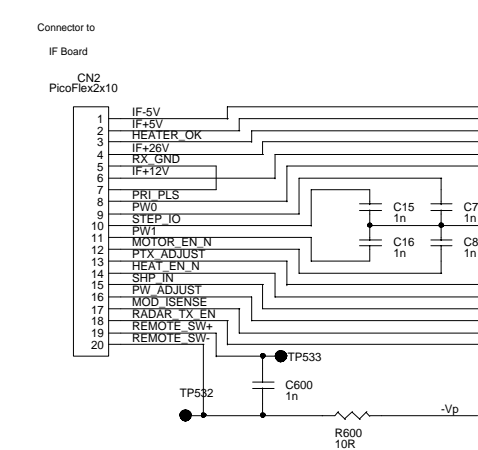
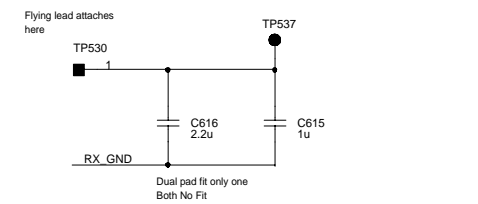
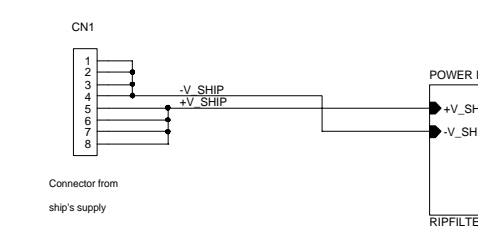
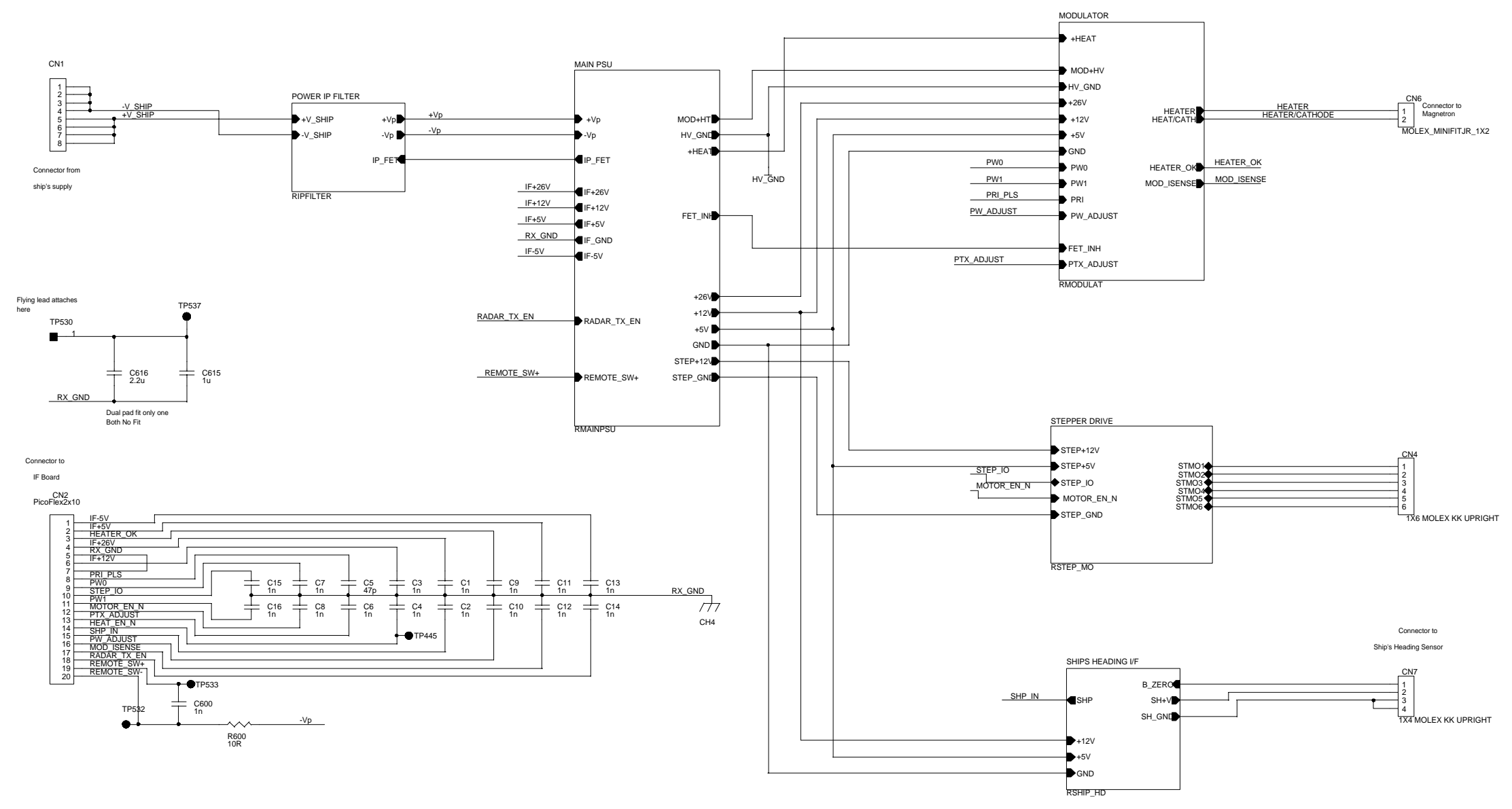

Orcad Schematic / Part Field Allocation :

- #1 Footprint
- #2 Build Option (2R,4R,ALL,NF)
- #3 Tolerance/Rating
- #4 not used
- #5 not used
- #6 2kW Radome Build Option p/n
- #7 4kW Radome Build Option p/n
- #8 not used

Note:
Some part values change with build type
these are written as 2kW/4kW

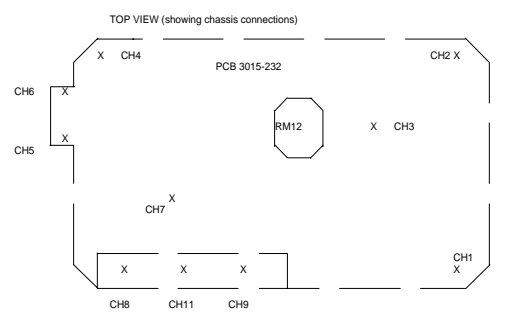
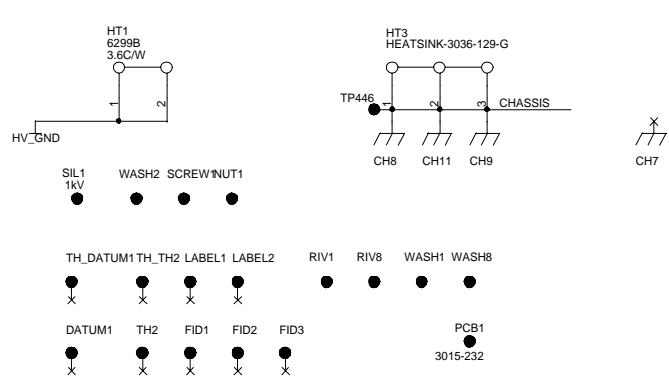

F	Mod M-01-0112 refers to alterations due to EMC changes. R621 changes to 330R. C616 becomes No Fit. Flying Lead Assy removed. Still refers to Issue B of PCB	25/09/01
E	Test Points with refs. higher than 600 inc. changed to be 500's. Still refers to Issue B of PCB	12/03/01
D	Alterations due to EMC failures. Refers to Issue B of PCB	20/02/01
C	Corrections to previous issue	05/02/01
B	Refers to Issue A of PCB	11/10/00
Axx	Initial drafts	01/08/00
Issue	Description of Change	Date

THE INFORMATION CONTAINED HEREIN SHALL NOT BE REPRODUCED IN WHOLE OR IN PART WITHOUT THE PRIOR WRITTEN PERMISSION OF RAYMARINE LTD.

Raymarine
ON BOARD

© 2001 Raymarine Ltd.

Title	Pathfinder Radar : Radome2 Modulator		
Size	Document Number	Drawn	Iss.
A2	4473-002	Checked	F
Date:	Thursday, September 27, 2001	Approved	
		Sheet	1 of 6

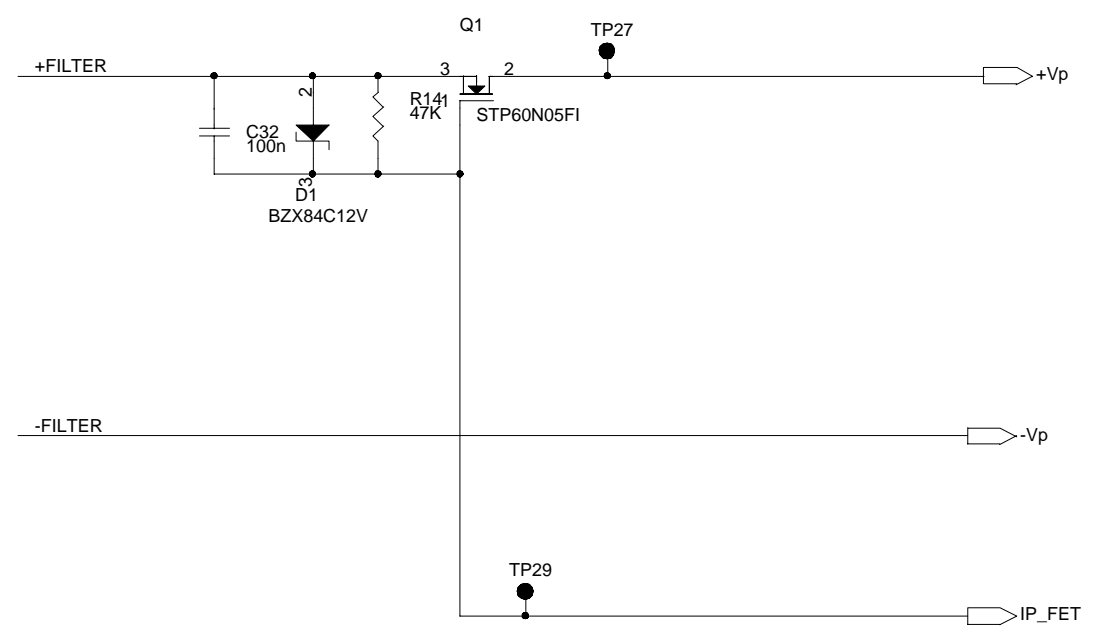
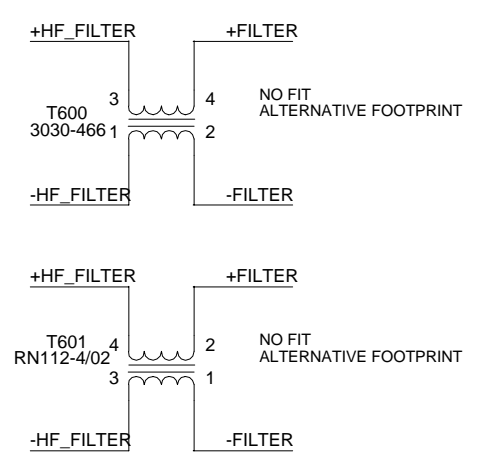
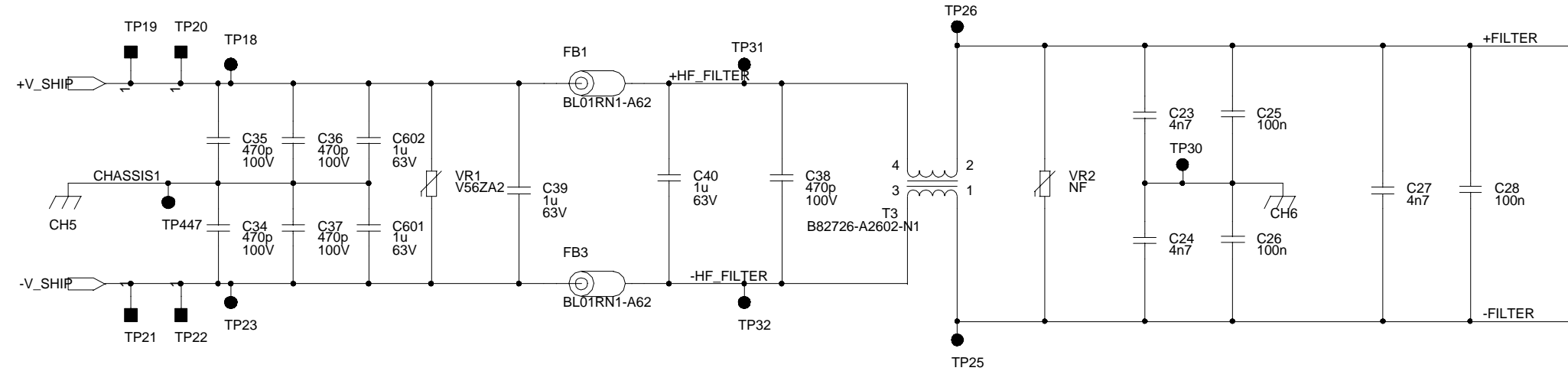

THE INFORMATION CONTAINED
HEREIN SHALL NOT BE REPRODUCED
IN WHOLE OR IN PART WITHOUT
THE PRIOR WRITTEN PERMISSION OF
RAYMARINE LTD.

Raymarine
ON BOARD

© 2001 Raymarine Ltd.

Title POWER I/P FILTER			
Size A3	Document Number 4473-002	Drawn _____	Iss. F
Date: Tuesday, September 25, 2001		Checked _____	Approved _____
		Sheet 2	of 6

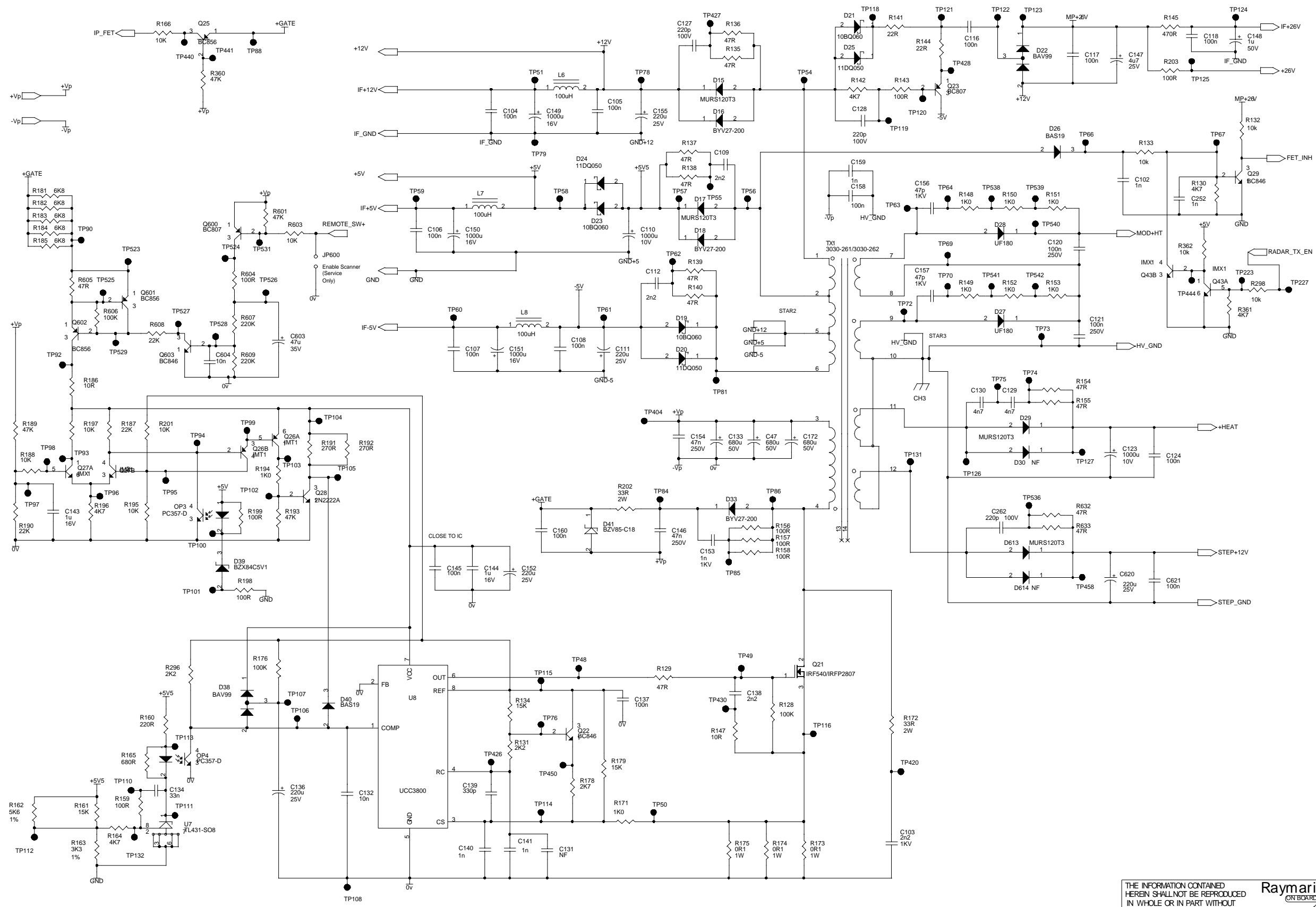

DANGER - HIGH VOLTAGE !

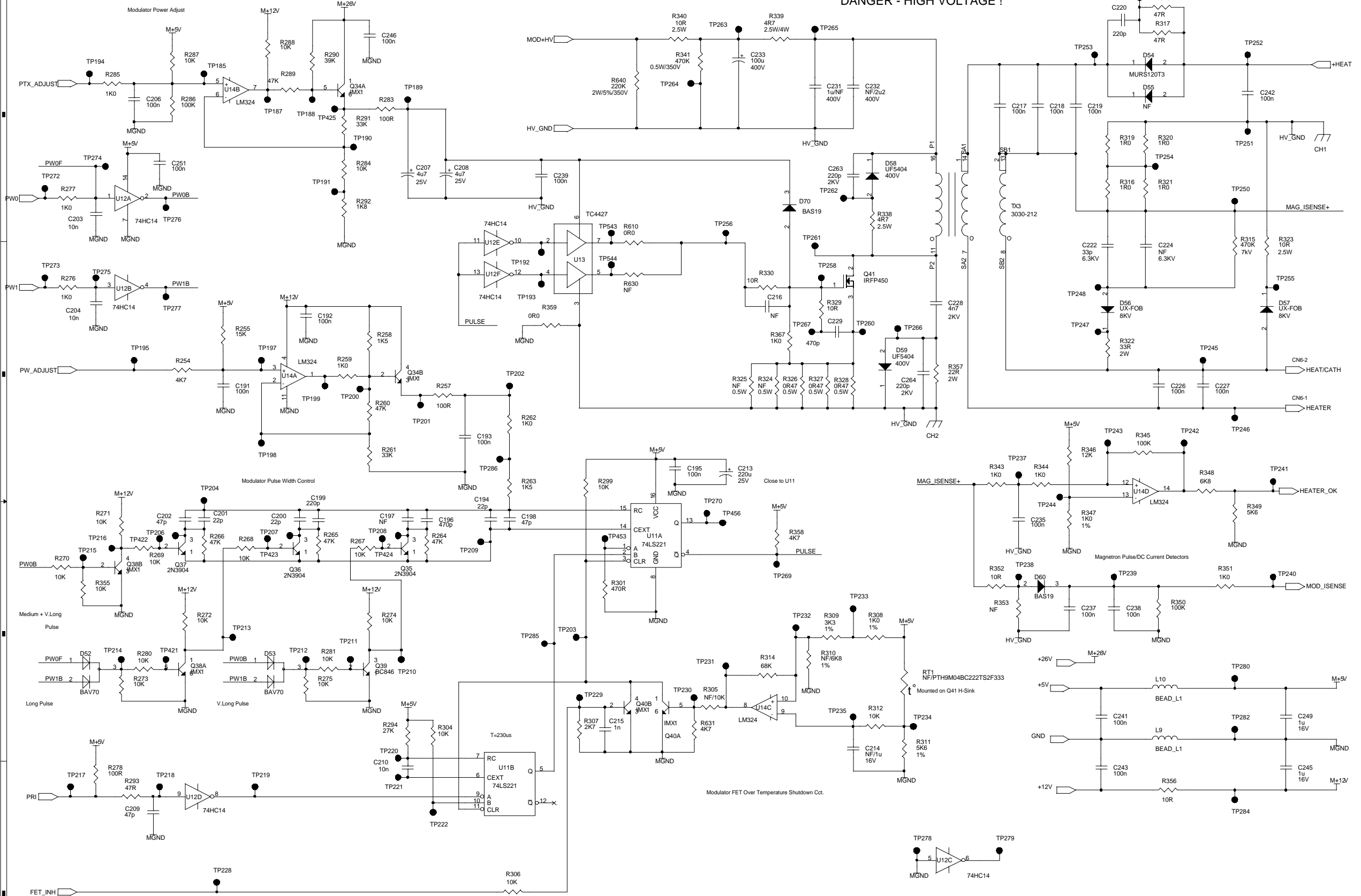

THE INFORMATION CONTAINED
HEREIN SHALL NOT BE REPRODUCED
IN WHOLE OR IN PART WITHOUT
THE PRIOR WRITTEN PERMISSION OF
RAYMARINE LTD.

Raymarine
ON BOARD

© 2001 Raymarine Ltd.

Title	MkJ Modulator	Drawn		Iss.	
Size	A2	Document Number	4473-002	Checked	
Date	Tuesday, September 25, 2001	Approved		Sheet	4 of 6

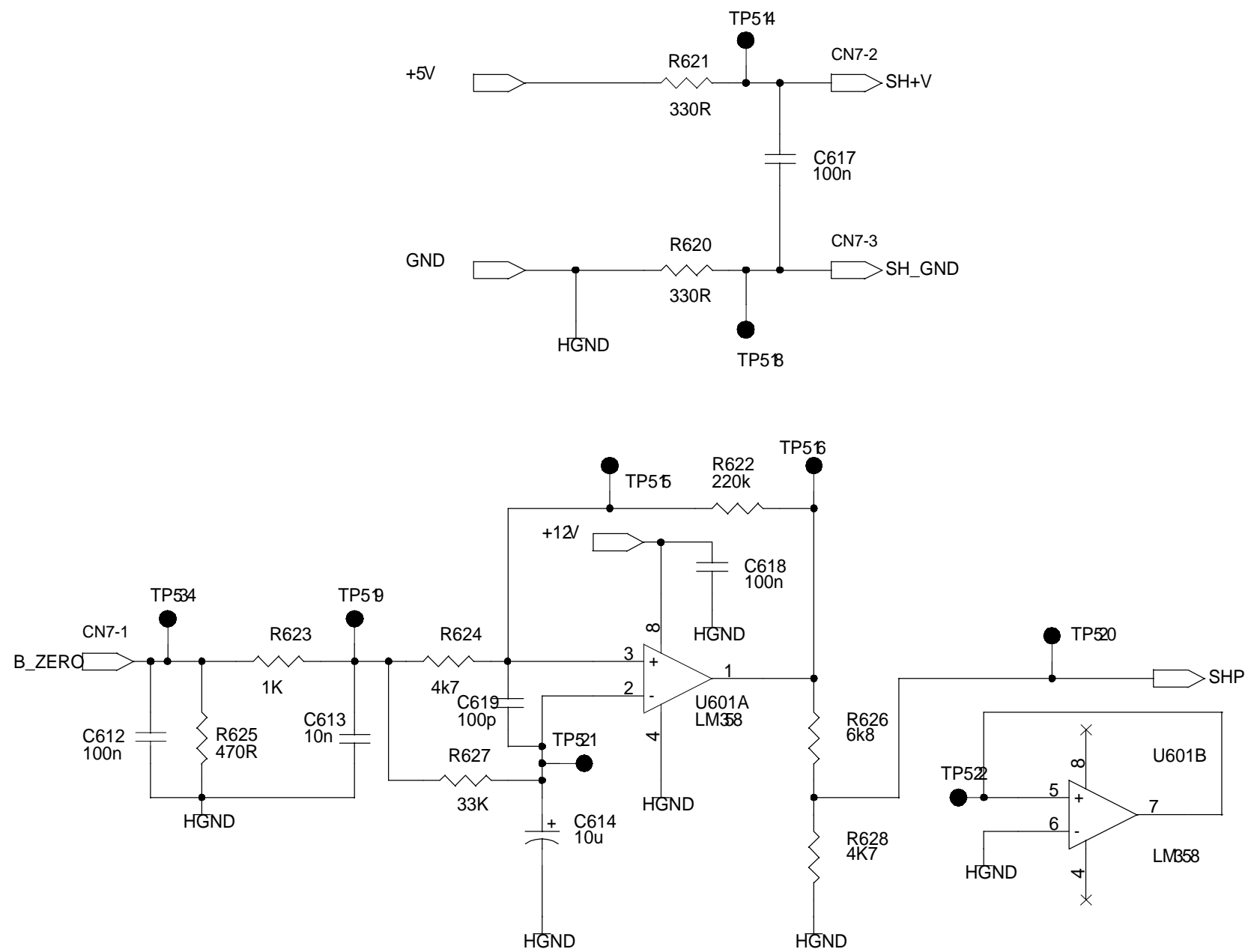

THE INFORMATION CONTAINED
HEREIN SHALL NOT BE REPRODUCED
IN WHOLE OR IN PART WITHOUT
THE PRIOR WRITTEN PERMISSION OF
RAYMARINE LTD.

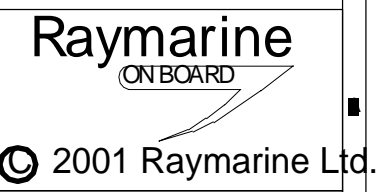

Title Ships Heading Interface			
Size A4	Document Number 4473-002	Drawn	Iss. F
		Checked	
		Approved	
Date: Tuesday, September 25, 2001	Sheet 5	of 6	

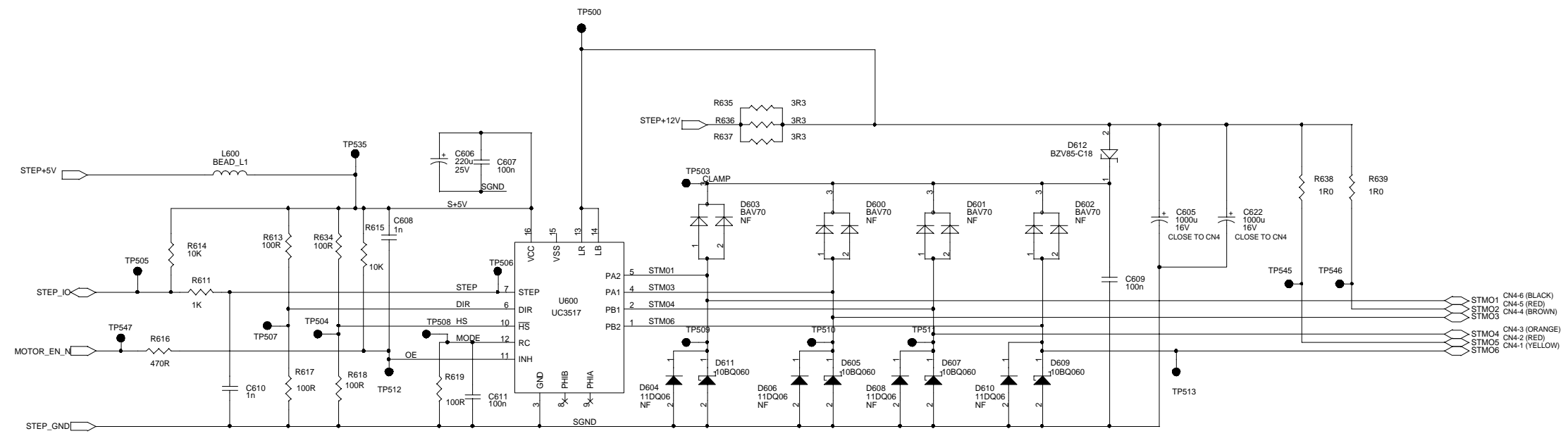

Alternative Stepper Motor Driver: UC3517.
 Charge Parts as follows -
 Fit U600 in place of U602.
 R617, R618 fit 100R
 R613, R634 NF
 D600, 601, 602, 603 fit BAV70
 R619 fit 47K
 C611 fit 100n

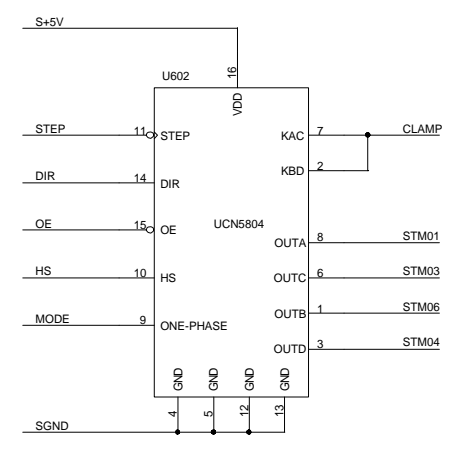

NOTE:
DISTRIBUTED MICROWAVE COMPONENTS

- STUB
- HIGH IMPEDANCE LINE
U/D - UPSIDE DOWN COMPONENTS

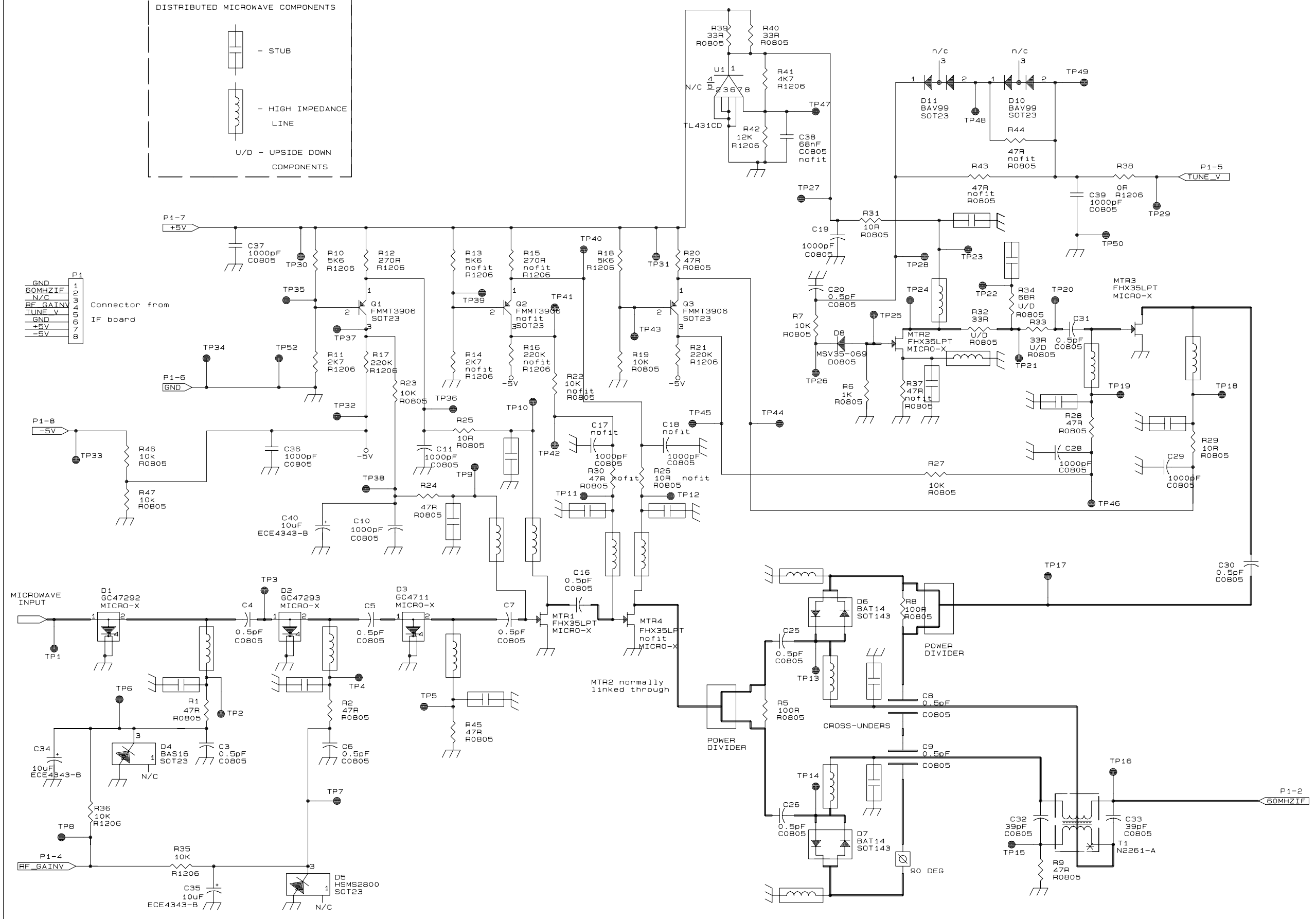

LOW NOISE CONVERTER / LIMITER

Revision L schematic reflects Issue F board

Raytheon Marine Europe ANCHORAGE PARK, PORTSMOUTH HAMPSHIRE PO3 5TD		
Title Low Noise Converter (LNC)		
Size	Document Number	REV
C	4346-028	L
Date:	October 13, 1997	Sheet 1 of 1

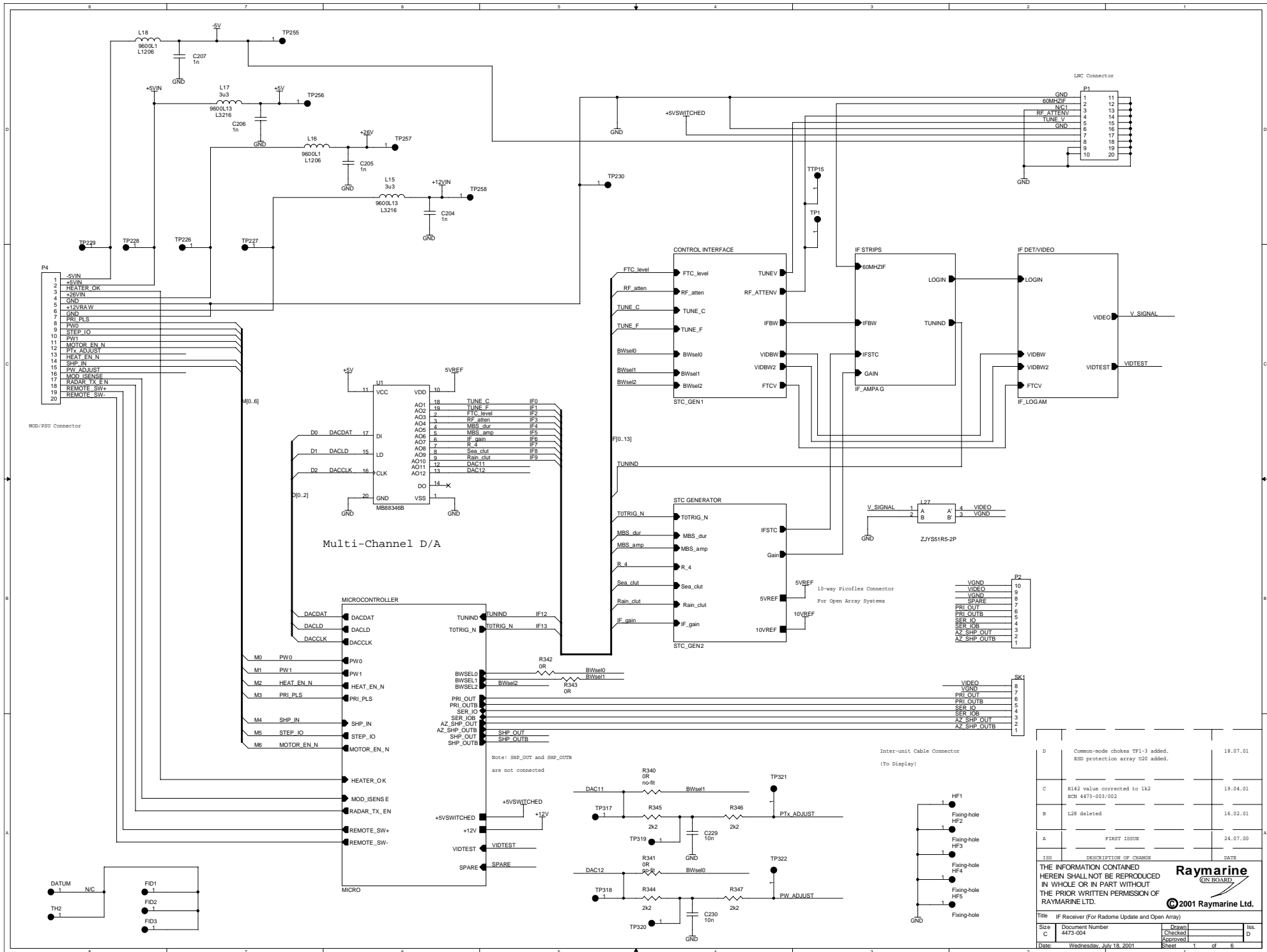

REV	DESCRIPTION OF CHANGE	DATE
D	Common-mode chokes TP1-3 added. ESD protection array U20 added.	18.07.01
C	R142 value corrected to 1k2 sctn 4473-003/002	19.04.01
B	L28 deleted	16.02.01
A	FIRST ISSUE	24.07.00

REV	DESCRIPTION OF CHANGE	DATE
<p>THE INFORMATION CONTAINED HEREIN SHALL NOT BE REPRODUCED IN WHOLE OR IN PART WITHOUT THE PRIOR WRITTEN PERMISSION OF RAYMARINE LTD.</p> <p style="text-align: right;">Raymarine ON BOARD</p> <p style="text-align: right;">© 2001 Raymarine Ltd.</p>		
Title IF Receiver (For Ratsome Update and Open Array)		
Size C	Document Number 4473-004	Drawn _____ Checked _____ Approved _____
Date: Wednesday, July 18, 2001	Sheet 1 of 6	Rev. D

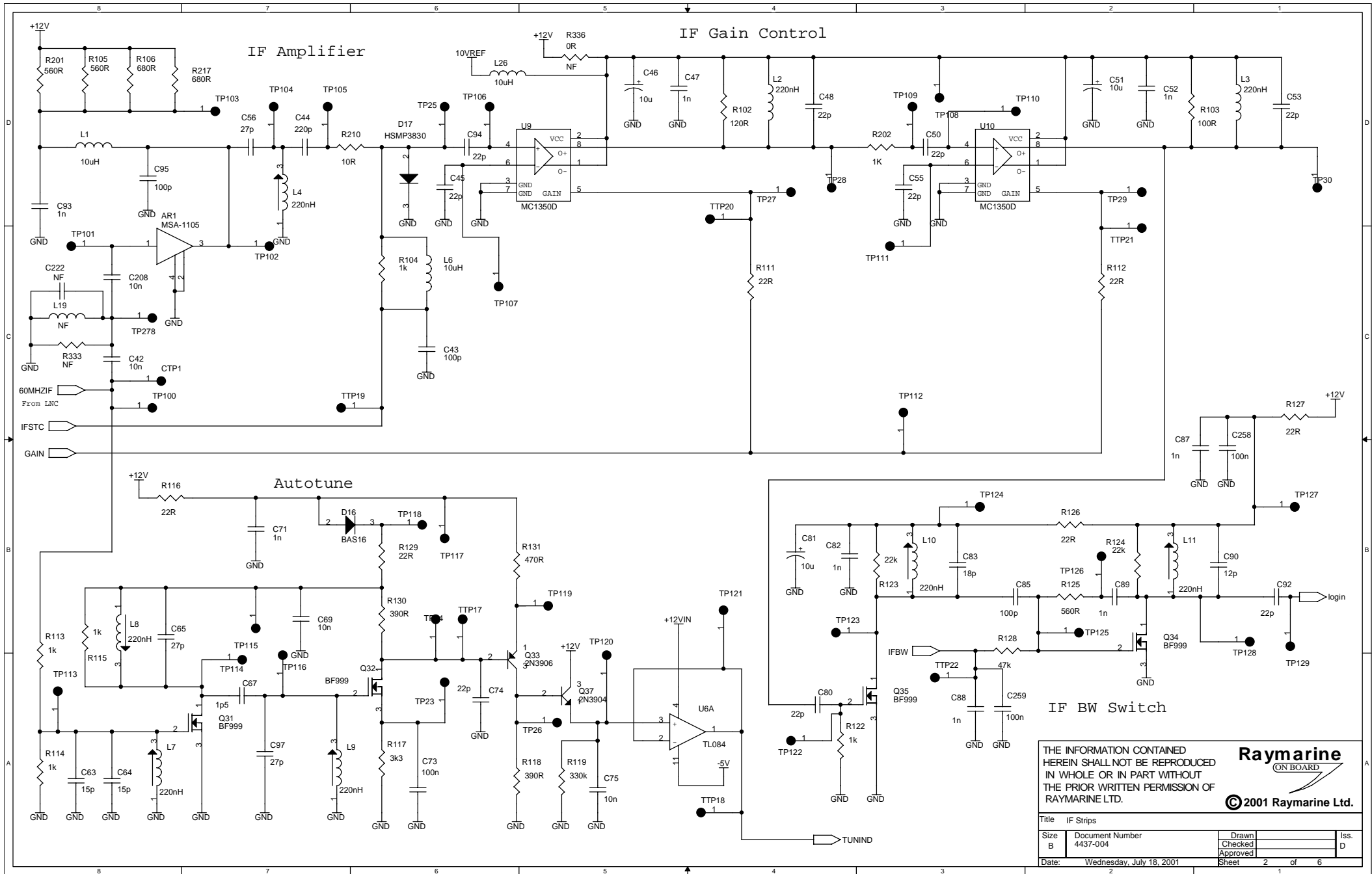

THE INFORMATION CONTAINED
HEREIN SHALL NOT BE REPRODUCED
IN WHOLE OR IN PART WITHOUT
THE PRIOR WRITTEN PERMISSION OF
RAYMARINE LTD.

Raymarine
ON BOARD

© 2001 Raymarine Ltd.

Title IF Strips			
Size B	Document Number 4437-004	Drawn	Iss. D
		Checked	
		Approved	
Date: Wednesday, July 18, 2001		Sheet 2	of 6

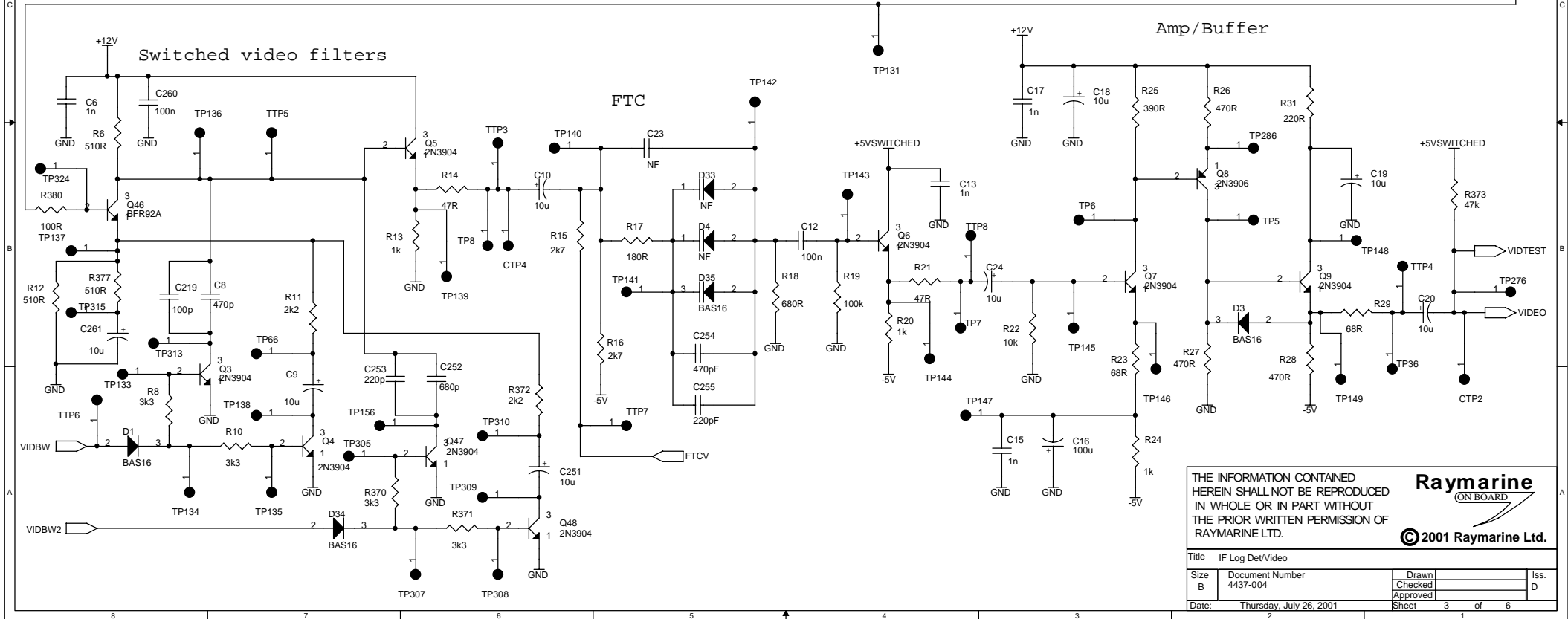
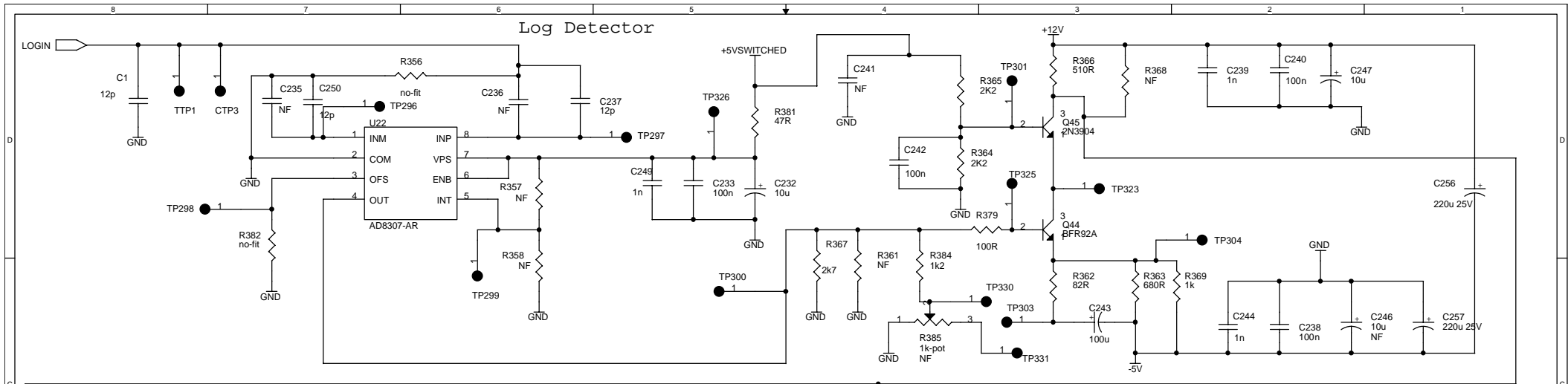

THE INFORMATION CONTAINED
HEREIN SHALL NOT BE REPRODUCED
IN WHOLE OR IN PART WITHOUT
THE PRIOR WRITTEN PERMISSION OF
RAYMARINE LTD.

Raymarine
ON BOARD
© 2001 Raymarine Ltd.

Title IF Log Det/Video			
Size B	Document Number 4437-004	Drawn	Iss. D
		Checked	
		Approved	
Date: Thursday, July 26, 2001		Sheet 3	of 6

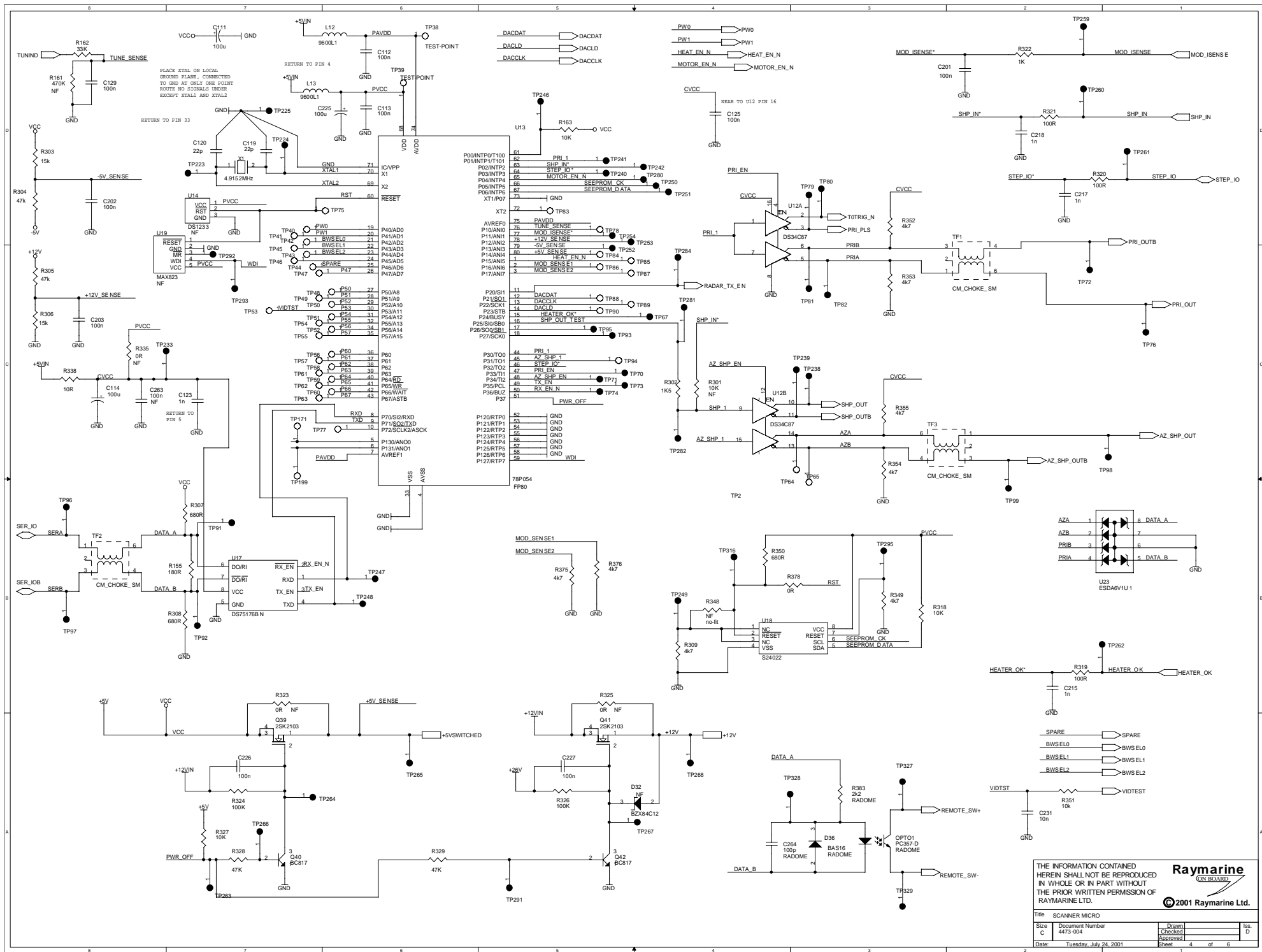

THE INFORMATION CONTAINED HEREIN SHALL NOT BE REPRODUCED IN WHOLE OR IN PART WITHOUT THE PRIOR WRITTEN PERMISSION OF RAYMARINE LTD.



© 2001 Raymarine Ltd.

Title: SCANNER MICRO			
Size: C	Document Number: 4473-004	Drawn: _____	Iss. D
Date: Tuesday, July 24, 2001		Checked: _____	
		Approved: _____	
		Sheet: 1	of 6

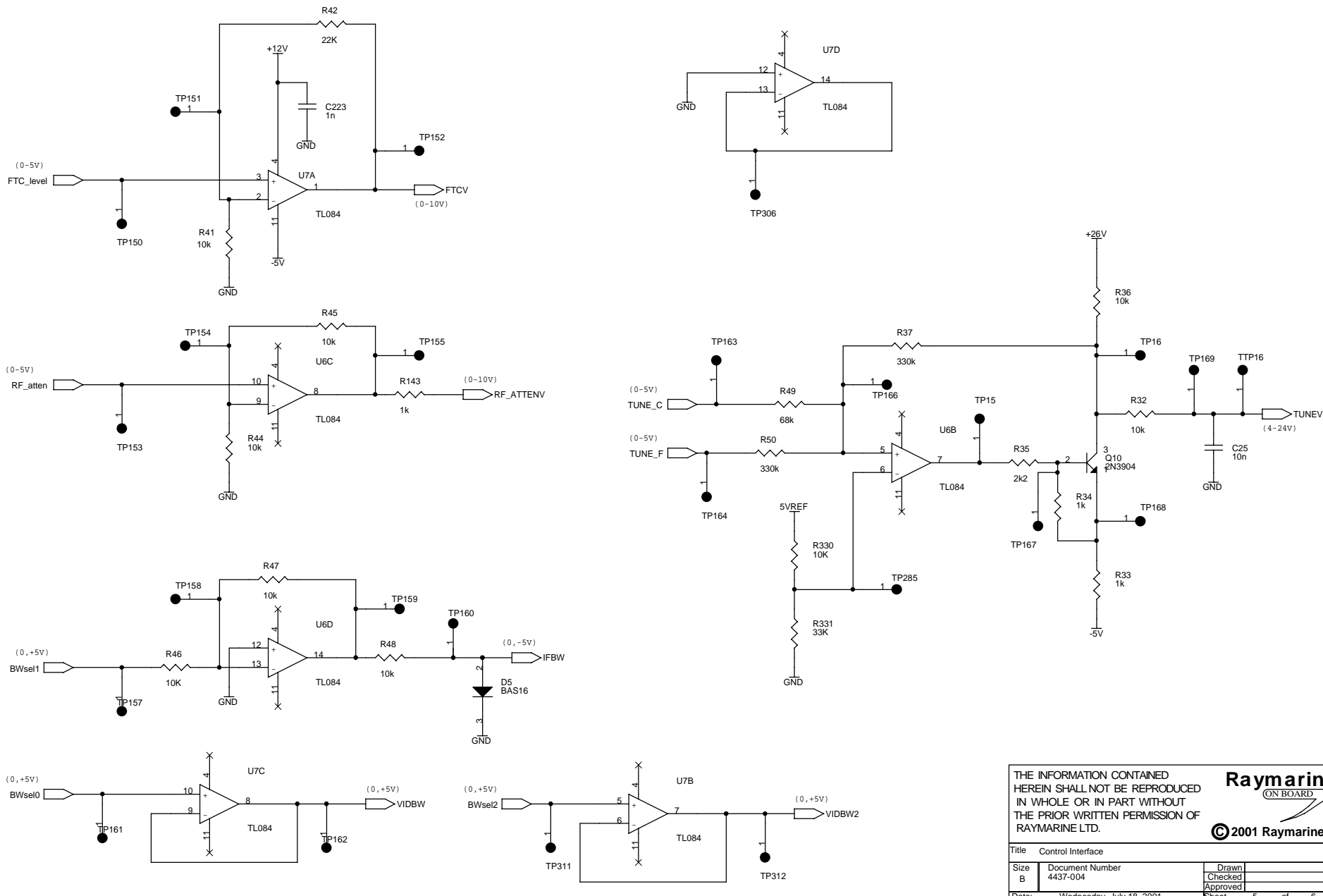

THE INFORMATION CONTAINED
HEREIN SHALL NOT BE REPRODUCED
IN WHOLE OR IN PART WITHOUT
THE PRIOR WRITTEN PERMISSION OF
RAYMARINE LTD.

Raymarine
ON BOARD

© 2001 Raymarine Ltd.

Title Control Interface			
Size B	Document Number 4437-004	Drawn	Iss. D
		Checked	
		Approved	
Date: Wednesday, July 18, 2001		Sheet 5	of 6

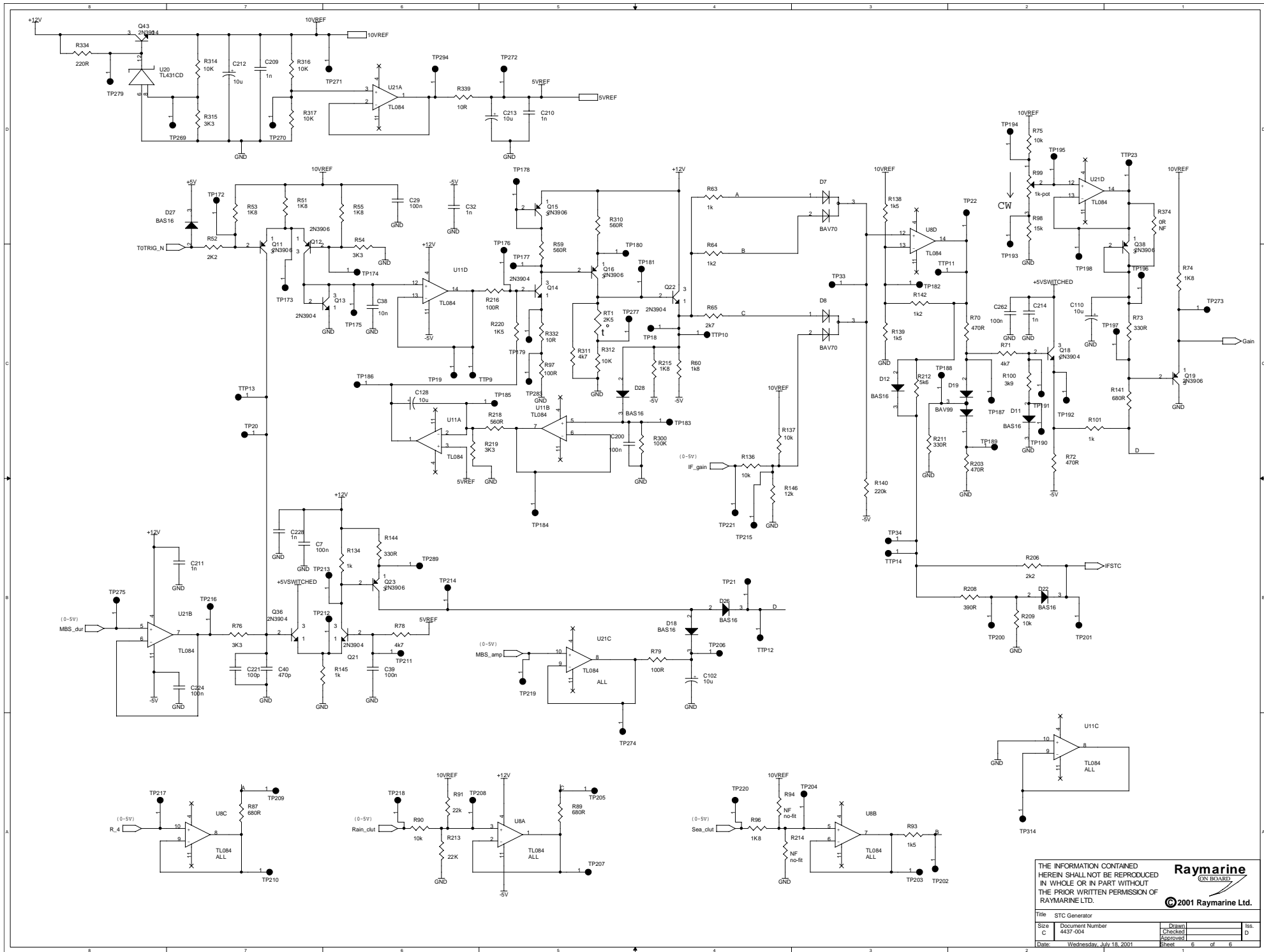

THE INFORMATION CONTAINED
HEREIN SHALL NOT BE REPRODUCED
IN WHOLE OR IN PART WITHOUT
THE PRIOR WRITTEN PERMISSION OF
RAYMARINE LTD.



© 2001 Raymarine Ltd.

Title: STC Generator		Drawn: _____		Iss: _____	
Size: C		Document Number: 4437-004		Checked: _____	
Date: Wednesday, July 18, 2001		Approved: _____		D: _____	
		Sheet: 1		6 of 6	