

RADIO FREQUENCY INVESTIGATION LTD

Ewhurst Park
Ramsdell
Basingstoke
Hampshire
England
RG26 5RQ

Switchboard Tel: (+44) 01256 851193
Accounts Tel: (+44) 01256 855490
Sales Tel: (+44) 01256 855400
Fax: (+44) 01256 851192

TEST REPORT FROM RADIO FREQUENCY INVESTIGATION LTD.

Test Of: Raytheon Marine 2kW Pathfinder
SL72 (LCD Display) and SV72 (CRT Display)
To: FCC Part 80 and FCC part 2

[Leisure Marine Equipment]

Test Report Serial No:
RFI/MICB1/RP34964A

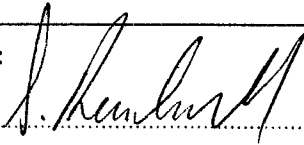
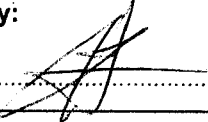
This Test Report Is Issued Under The Authority Of Brian Watson, Technical Director:	
Tested By: 	Checked By: 
Report Copy No: 03	
Issue Date: 28 May 1997	Test Dates: 28 th February 1997 to 1 st March 1997 1 st April 1997 to 4 th April 1997 1 st May 1997

This report may be reproduced in full. Partial reproduction may only be made with the written consent of Radio Frequency Investigation Ltd..
The results in this report apply only to the sample(s) tested.

Ayrshire

Dunlop House, Dunlop, Ayrshire, Scotland KA3 4BD.
Tel: (+44) 01560 483813 Fax: (+44) 01560 484408

Registered in England, No. 211 7901.
Registered Office: Ewhurst Park, Ramsdell, Basingstoke, Hampshire RG26 5RQ



RADIO FREQUENCY INVESTIGATION LTD.

TEST REPORT

Microwave Type Approval Department

S.No. RFI/MICB1/RP34964A

Page 2 of 38

Issue Date: 28 May 1997

**Test Of: Raytheon Marine 2kW Pathfinder
SL72 (LCD Display) and SV72 (CRT Display)**

To: FCC Part 80 and FCC part 2

This page has been left intentionally blank.

Test Of: Raytheon Marine 2kW Pathfinder
SL72 (LCD Display) and SV72 (CRT Display)
To: FCC Part 80 and FCC part 2

Table of Contents

1. Client Information	4
2. Equipment Under Test (EUT).....	5
3. Test Specification, Methods & Procedures	8
4. Deviations From The Test Specification.....	10
5. Operation Of The EUT During Testing	11
6. Summary Of Test Results.....	12
7. Measurements, Examinations And Derived Results	15
8. Measurement Uncertainty.....	28
Appendix 1. Test Equipment Used	29
Appendix 2. Measurement Methods	32
Appendix 3. Test Configuration Drawings.....	34
Appendix 4. Graphical Test Results	37

Test Of: Raytheon Marine 2kW Pathfinder
SL72 (LCD Display) and SV72 (CRT Display)
To: FCC Part 80 and FCC part 2

1. Client Information

Company Name:	Raytheon Marine Europe Ltd
Address:	Anchorage Park Portsmouth Hants PO3 5TD
Contact Name:	Mr C Bird

Test Of: Raytheon Marine 2kW Pathfinder
 SL72 (LCD Display) and SV72 (CRT Display)
 To: FCC Part 80 and FCC part 2

2. Equipment Under Test (EUT)

The following information (with the exception of the Date of Receipt) has been supplied by the client:

2.1. Identification Of Equipment Under Test (EUT)

Brand Name:	Raytheon
Model Name or Number:	Pathfinder 2 kW radar
Unique Type Identification:	SL72 (LCD Display)
Serial Number:	2005 (Radar scanner unit)
Country of Manufacture:	England
FCC ID Number:	ASLMTX2
Date of Receipt:	1 April 1997

Brand Name:	Raytheon
Model Name or Number:	Pathfinder 2 kW radar
Unique Type Identification:	SV72 (CRT Display)
Serial Number:	2005 (radar scanner unit)
Country of Manufacture:	England
FCC ID Number:	ASLMTX2
Date of Receipt:	1 April 1997

2.2. Description Of EUT

2kW Radar Transmitter with 18 inch microstrip patch array antenna

Model SL72 is supplied with a 7 inch liquid crystal display (serial number: L1009)

Model SV72 is supplied with a 7 inch cathode ray tube display (serial number C3001)

2.3. Modifications Incorporated In EUT

None stated by client.

Test Of: Raytheon Marine 2kW Pathfinder
SL72 (LCD Display) and SV72 (CRT Display)

To: FCC Part 80 and FCC part 2

2.4. Additional Information Related To Testing

Power Supply Requirement:	Nominal 12 to 24V dc Supply
Intended Operating Environment:	Onboard Maritime Vessel
Weight:	Scanner 6.5 kg; CRTDisplay 4.3 kg; LCD Display: 1.2kg
Dimensions:	Scanner 468 diameter by 227 CRT Display 240 x 220 x 260 LCD Display 220 x 202 x 75
Interface Ports:	Scanner to display Power and 2 NMEA in "Seataalk" or NMEA out

Test Of: Raytheon Marine 2kW Pathfinder
SL72 (LCD Display) and SV72 (CRT Display)
To: FCC Part 80 and FCC part 2

2.5. Support Equipment

No support equipment was required to exercise the EUT during testing.

Test Of: Raytheon Marine 2kW Pathfinder
SL72 (LCD Display) and SV72 (CRT Display)
To: FCC Part 80 and FCC part 2

3. Test Specification, Methods & Procedures

3.1. Test Specification

Reference:	FCC Part 80 and FCC Part 2
Title:	Code of Federal Regulations, Part 80 (47CFR) Stations in the maritime services Code of Federal Regulations, Part 2 (47CFR) Frequency Allocations and radio treaty matters; general rules and regulations
Comments:	A description of the test facility used for this test is on file with, and has been accepted by, the Federal Communications Commission as required by Section 2.948 of Federal Rules.
Purpose of Test:	To determine whether the equipment complied with the requirements of the specification for the purposes of verification.

3.2. Methods And Procedures

The methods and procedures used were as detailed in:

ANSI C63.2 (1987)

Title: American National Standard for Instrumentation - Electromagnetic noise and field strength.

ANSI C63.4 (1992)

Title: American National Standard Methods of Measurement of Electromagnetic Emissions from Low Voltage Electrical and Electronic Equipment in the Range of 9 kHz to 40 GHz.

ANSI C63.5 (1988)

Title: American National Standard for the Calibration of antennas used for Radiated Emission measurements in Electromagnetic Interference (EMI) control.

ANSI C63.7 (1988)

Title: American National Standard Guide for Construction of Open Area Test Sites for performing Radiated Emission Measurements.

CISPR 16 (1987)

Title: Specification for Radio Interference measuring apparatus and measurement methods.

Test Of: Raytheon Marine 2kW Pathfinder
SL72 (LCD Display) and SV72 (CRT Display)
To: FCC Part 80 and FCC part 2

3.3. Definition Of Measurement Equipment

The measurement equipment used complied with the requirements of the standards referenced in the Methods & Procedures section above. Appendix 1 contains a list of the test equipment used.

RADIO FREQUENCY INVESTIGATION LTD.

TEST REPORT

Microwave Type Approval Department

S.No. RFI/MICB1/RP34964A

Page 10 of 38

Issue Date: 28 May 1997

Test Of: Raytheon Marine 2kW Pathfinder
SL72 (LCD Display) and SV72 (CRT Display)

To: FCC Part 80 and FCC part 2

4. Deviations From The Test Specification

2.987(d) Modulation characteristics – *Other types of equipment*. No curves supplied.

Test Of: Raytheon Marine 2kW Pathfinder
SL72 (LCD Display) and SV72 (CRT Display)
To: FCC Part 80 and FCC part 2

5. Operation Of The EUT During Testing

5.1. Operating Conditions

5.1.1. **9kHz to 1GHz:** The EUT was located in a covered turntable site on the 3M open area test site environment for radiated emissions

5.1.2. **1GHz to 95GHz:** The EUT was located in a covered 3M open area test site for radiated emissions.

5.1.3. The EUT was located in a laboratory environment for all other tests.

5.1.4. During testing, the EUT was powered by a Nominal 12V dc supply.

5.2. Operating Modes

The EUT was tested in the following operating modes:

5.2.1. Radiated emissions Transmitting into a non-reflective load with the transmitter set to a six nautical mile range This mode was defined by the client as being likely to be the worst case with regards EMC

5.2.2. For other testing, the range was set to:

Short Pulse	(short range)
Medium Pulse	(medium range)
Long Pulse	(long range)

5.3. Configuration And Peripherals

The EUT was tested in the following configuration:

5.3.1. The EUT was in a typical configuration, with a CRT or LCD display

5.3.2. This mode was defined by the client as being likely to be the worst case with regards EMC

5.3.3. Appendix 1 of this report contains a full list of test equipment used and Appendix 3 contains a schematic diagram of the test configuration.

Test Of: Raytheon Marine 2kW Pathfinder
SL72 (LCD Display) and SV72 (CRT Display)

To: FCC Part 80 and FCC part 2

6. Summary Of Test Results

6.1. Summary Of Tests

6.1.1. Radiated Spurious Emissions

Frequency Range	Specification Reference	Compliance Status
9kHz to 100GHz	2.993 and 80.211(f)	Complied

6.1.2. Conducted Spurious Emissions

Frequency Range	Specification Reference	Compliance Status
9kHz to 100GHz	2.991 and 80.211(f)	Complied

6.1.3. RF Power Output

6.1.3.1. Peak Power

Specification Reference			
2.985(a) and 80.215(a)	Short Pulse/kWpk 0.518	Medium Pulse/kWpk 1.39	Long Pulse/kwPk 1.45

6.1.3.2. Average Power

Specification Reference			
2.985(a) and 80.215(a)	Short Pulse Ave/W 0.125	Medium Pulse Ave/W 0.525	Long Pulse/kwPk 0.719

6.1.3.3. Pulse Width

Specification Reference			
2.985(a) and 80.215(a)	Short Pulse/μS 0.107	Medium Pulse/μS 0.252	Long Pulse/μS 0.664

Test Of: Raytheon Marine 2kW Pathfinder
 SL72 (LCD Display) and SV72 (CRT Display)
 To: FCC Part 80 and FCC part 2

6.1.3.4. PRF

Specification Reference			
2.987(d)	Short Pulse/Hz 2253	Medium Pulse/Hz 1494	Long Pulse/Hz 746

6.1.4. Variation of Frequency with Voltage

Specification Reference	10.2 Vdc to 27.6 Vdc
2.995(d)	+0.43MHz to -0.00MHz

6.1.5. Variation of Frequency with Temperature

Specification Reference	-20°C to +50°C
2.995(a)	+7.86MHz to -1.74MHz

6.1.6. Occupied Bandwidth

Specification Reference			
2.989(i) and 80.205(a)	Short Pulse/MHz 44.42	Medium Pulse/MHz 21.98	Long Pulse/MHz 13.42

6.1.7. Transmitter Frequency Tolerance

Specification Reference	Compliance Status
80.209(b)	Complied

6.1.8. Supression of Interference Aboard Ships

Specification Reference	Transmitter Output Used	Status
80.217(b)	System in standby mode	Complied

RADIO FREQUENCY INVESTIGATION LTD.

TEST REPORT

Microwave Type Approval Department

S.No. RFI/MICB1/RP34964A

Page 14 of 38

Issue Date: 28 May 1997

**Test Of: Raytheon Marine 2kW Pathfinder
SL72 (LCD Display) and SV72 (CRT Display)**
To: FCC Part 80 and FCC part 2

6.2. Location Of Tests

All the measurements described in this report were performed at the premises of Radio Frequency Investigation Ltd, Ewhurst Park, Ramsdell, Basingstoke, Hampshire, RG26 5RQ, England.

Microwave Type Approval Department

Test Of: Raytheon Marine 2kW Pathfinder
SL72 (LCD Display) and SV72 (CRT Display)
To: FCC Part 80 and FCC part 2

7. Measurements, Examinations And Derived Results

7.1. General Comments

7.1.1. This section contains test results only. Details of the test methods and procedures can be found in Appendix 2 of this report.

7.1.2. The measurement uncertainties stated were calculated in accordance with the requirements of NAMAS Document NIS 81 with a confidence level of 95%. Please refer to Section 8 for details of measurement uncertainties.

7.1.3. The client declared the highest clock frequency of the EUT as 9.4GHz. Consequently, the tests were performed up to 95GHz (above tenth harmonic).

Test Of: Raytheon Marine 2kW Pathfinder
SL72 (LCD Display) and SV72 (CRT Display)
To: FCC Part 80 and FCC part 2

7.2. Field Strength Measurements

7.2.1. SV72 CRT System

Magnetic Field Strength Measurements (Frequency Range: 9kHz to 30MHz)

Electric Field Strength Measurements (Frequency Range: 30MHz to 1GHz)

7.2.1.1. Plots of the initial scans can be found in Appendix 4.

7.2.1.2. The following table lists frequencies at which emissions were measured using a Quasi-Peak detector (results incorporate antenna factors and cable losses):

Frequency (MHz)	Ant. Pol.	Q-P Level (dB μ V/m)	Limit (dB μ V/m)	Margin (dB)	Result
0.031593	V	98.1	135.17	37.07	Pass
0.031593	H	92.7	135.17	42.47	Pass
0.063161	V	90.4	135.17	44.77	Pass
0.063161	H	84.7	135.17	50.47	Pass
0.094733	V	85.4	135.17	49.77	Pass
0.094733	H	79.8	135.17	55.37	Pass
50.001	V	59.0	135.17	76.17	Pass
75.002	H	48.0	135.17	87.17	Pass
114.002	H	71.0	135.17	64.17	Pass
150.003	H	45.4	135.17	89.77	Pass
152.004	H	56.3	135.17	78.87	Pass
175.003	H	46.7	135.17	88.47	Pass
190.009	H	57.9	135.17	77.27	Pass
225.005	H	47.7	135.17	87.47	Pass
228.005	H	58.4	135.17	76.77	Pass
250.003	H	57.2	135.17	77.97	Pass
266.006	H	49.4	135.17	85.77	Pass
275.006	H	48.4	135.17	86.77	Pass
304.007	H	45.5	135.17	89.67	Pass

Test Equipment Used: [Listed under RFI asset numbers – See Appendix 1]

A026,A234, M002, M024, A259, S013, A276, A277, C326, C327, M117, M004, A023, A024, M003, M023, A007

Test Of: Raytheon Marine 2kW Pathfinder
SL72 (LCD Display) and SV72 (CRT Display)
To: FCC Part 80 and FCC part 2

7.2.2. - SL72 LCD System**Magnetic Field Strength Measurements (Frequency Range: 9kHz to 30MHz)****Electric Field Strength Measurements (Frequency Range: 30MHz to 1GHz)**

7.2.2.1. Plots of the initial scans can be found in Appendix 4.

7.2.2.2. The following table lists frequencies at which emissions were measured using a Quasi-Peak detector (results incorporate antenna factors and cable losses):

Frequency (MHz)	Ant. Pol.	Q-P Level (dB μ V/m)	Limit (dB μ V/m)	Margin (dB)	Result
45.123	V	41.0	135.17	94.17	Pass
54.628	V	34.3	135.17	100.87	Pass
59.378	V	31.2	135.17	103.97	Pass
114.002	H	55.9	135.17	79.27	Pass
152.002	H	51.6	135.17	83.57	Pass
190.004	H	56.1	135.17	79.07	Pass
228.000	H	44.9	135.17	90.27	Pass
266.006	H	49.0	135.17	86.17	Pass
304.008	H	45.9	135.17	89.27	Pass
342.009	H	49.1	135.17	86.07	Pass
418.006	V	48.7	135.17	86.47	Pass
570.012	H	51.8	135.17	83.37	Pass

Test Equipment Used: [Listed under RFI asset numbers – See Appendix 1]

A026, A234, M002, M024, A259, S013, A276, A277, C326, C327, M117, M004, A023, A024, M003, M023, A007

Test Of: Raytheon Marine 2kW Pathfinder
SL72 (LCD Display) and SV72 (CRT Display)
To: FCC Part 80 and FCC part 2

7.2.3. Electric Field Strength Measurements – SV72 CRT System
(Frequency Range: 1GHz to 95GHz)

7.2.3.1. The client declared the highest clock frequency of the EUT as 9.4GHz. Consequently, the tests were performed up to 95GHz (above tenth harmonic).

7.2.3.2. Electric field strength measurements above 1GHz were performed exclusively using the CRT display system. It is believed that a) the CRT system is the worst case device and b) it was unlikely that either system would produce emissions above 1GHz.

7.2.3.3. Plots of the initial scans can be found in Appendix 4. Please note; the limit, 135.17dB μ V/m, is beyond the dynamic range of the analyser and as such, could not be displayed on screen or plotted

7.2.3.4. The following tables list frequencies at which emissions were measured using Peak detector functions:

Test Of: Raytheon Marine 2kW Pathfinder
SL72 (LCD Display) and SV72 (CRT Display)
To: FCC Part 80 and FCC part 2

7.2.3. Electric Field Strength Measurements – SV72 CRT System
(Frequency Range: 1GHz to 100GHz) - continued

Highest Peak Level:

Frequency Span Range (GHz)	Actual Peak Level (dB μ V/m)	Peak Limit (dB μ V/m)	Result
1.0 to 2.0	67.6	135.17	Pass
2.0 to 4.0	66.4	135.17	Pass
4.0 to 6.0	71.3	135.17	Pass
6.0 to 8.2	71.8	135.17	Pass
8.2 to 12.5	129.0	135.17	Pass
12.5 to 18.0	100.22	135.17	Pass
18.0 to 26.5	90.1	135.17	Pass
26.5 to 29.5	91.9	135.17	Pass
29.5 to 35.0	87.8	135.17	Pass
35.0 to 40.0	92.6	135.17	Pass
40.0 to 50.0	92.8	135.17	Pass
50.0 to 59.7	86.9	135.17	Pass
59.7 to 75.0	98.3	135.17	Pass
75.0 to 95.0	130.1	135.17	Pass

Test Equipment Used: [Listed under RFI asset numbers – See Appendix 1]

M072, M074, M150, M151, G051, M076, C183, C181, A253, A254, A255, A256, A027, A031, A331, A201, A202, A203, A347, RFI002, RFI003, RFI004, RME001.

Test Of: Raytheon Marine 2kW Pathfinder
SL72 (LCD Display) and SV72 (CRT Display)
To: FCC Part 80 and FCC part 2

7.3. Conducted Emissions

7.3.1. Peak Detector Measurements On RF port

7.3.1.1. Plots of the scans can be found in Appendix 4.

7.3.1.2. The following table lists frequencies at which emissions or the highest noise floor were measured using a Peak detector:

Frequency (GHz)	Level dBc	Limit	Margin (dB)	Result
9kHz to 150kHz	<-95.0	-41.6	>53.4	Complied
150kHz to 30MHz	<-94.7	-41.6	>53.1	Complied
0.03 to 1	<-71	-41.6	>29.4	Complied
1 to 8	<-67	-41.6	>25.4	Complied
8 to 9.31	<-65	-41.6	>23.4	Complied
9.51 to 13	<-69	-41.6	>27.4	Complied
13 to 20	<-68	-41.6	>26.4	Complied
20 to 26.5	<-67	-41.6	>25.4	Complied
26.5 to 40	<-70	-41.6	>28.4	Complied
40 to 60	<-71	-41.6	>29.4	Complied
60 to 75	<-69	-41.6	>27.4	Complied
75 to 100	<-48	-41.6	>6.4	Complied

Note 1: Plots above 26.5 GHz have a 20 dB Attenuator removed, hence the dBc figure is 20 greater than apparent from the graphs.

Note 2: The design of the RF coupling from the magnetron to the antenna (a RF coupled stub inside the cavity to a tuned antenna) formed an effective high pass / bandpass filter arrangement. The peak energy level of radar requires considerable attenuation in order to prevent the analyser from going into compression. This limits the maximum dBc figure that can be obtained without changing the RBW of the analyser. Since the signal is wideband compared to the RBW, it is critical to the measurement accuracy that the RBW settings remain consistent throughout the testing where possible.

Test Equipment Used: [Listed under RFI asset numbers – See Appendix 1]

M069, M076, A388, C171, A393, A324, C170, M072, RME001, RME002

Microwave Type Approval Department

Test Of: Raytheon Marine 2kW Pathfinder
SL72 (LCD Display) and SV72 (CRT Display)
To: FCC Part 80 and FCC part 2

7.4. Peak power (Measured and Calculated) Summary.

Pulse Mode	Average Power, dBm	Corrected Power, W	P.R.F Hz	Pulse Width, uS	Peak Power, kWp
Short	-40.23	0.125	2253	0.107	0.518
Medium	-34.0	0.525	1497	0.252	1.39
Long	-32.63	0.719	746	0.664	1.45

The following sub sections detail the results required to make the above calculation:

Test Equipment Used: [Listed under RFI asset numbers – See Appendix 1]

M151, M150, A223, M029, A388, RME001, RME002, C171

Test Of: Raytheon Marine 2kW Pathfinder
SL72 (LCD Display) and SV72 (CRT Display)

To: FCC Part 80 and FCC part 2

7.4.1. Average power

These measurements were performed with the Boonton Power meter and sensor connected to the EUT via a 40 dB coupler, 20 dB in line Attenuator and microwave coax cable.

Sample Calculation

Pulse Mode = Long
 Measured Power, dBm = -32.63
 Coupler and cable correction, dB = 61.2
 Power Output, Watts, Ave. = 0.719

Pulse Mode	Measured dBm	Coupler and cable Attenuation, dB	Corrected Watts, Ave.
Short	-40.23	61.2	0.125
Medium	-34.0	61.2	0.525
Long	-32.63	61.2	0.719

7.4.2. Pulse width

7.4.2.1. Plots can be found in Appendix 4.

In order to determine the characteristics of the various pulses, an oscilloscope was connected, through a HP detector and an attenuator to the test set up.

Pulse Mode	Measured Pulse Width μ Sec
Short	0.107
Medium	0.252
Long	0.664

Microwave Type Approval Department

Test Of: Raytheon Marine 2kW Pathfinder
SL72 (LCD Display) and SV72 (CRT Display)
To: FCC Part 80 and FCC part 2

7.4.3. PRF

7.4.3.1. Plots can be found in Appendix 4.

In order to determine the characteristics of the various pulses, an oscilloscope was connected, through an HP detector and an attenuator to the test set up.

Pulse Mode	Measured P.R.F. Hz
Short	2253
Medium	1497
Long	746

Test Of: Raytheon Marine 2kW Pathfinder
SL72 (LCD Display) and SV72 (CRT Display)
To: FCC Part 80 and FCC part 2

7.5. Variation of frequency with voltage – Medium Pulse

7.5.1. Plots can be found in Appendix 4.

The frequency of the EUT was measured at each voltage.

% of nominal Volts	Volts dc	Measured frequency GHz	Delta from 9.41 GHz in MHz
85 (12 V supply)	10.2	9.41016	0.16
100 (12 V supply) Nominal	12.0	9.41000	0.0
100 (24 V supply)	24.0	9.41043	0.43
115 (24 V supply)	27.6	9.41026	0.26

Battery End Point: 10.2 Volts

Note: The equipment can be operated from 12 or 24 Volts sources without requiring any changes. Therefore the testing was performed at 85 % of the lowest to 115 % of the highest operating Voltage

Test Equipment Used: [Listed under RFI asset numbers – See Appendix 1]

M069, A388, M058, C171, RME001, RME002

7.6. Variation of frequency with Temperature – Medium Pulse

The EUT was cooled to -20 °C. After 30 minutes the EUT was turned on and allowed to stabilise until there was no measurable frequency change. The frequency was recorded and the chamber temperature stepped up by 10 °C. This process was repeated until the EUT was at + 50 °C.

Temperature °C	Measured frequency GHz	Delta from 9.41 GHz in MHz
-20	9.41786	7.86
-10	9.41673	6.73
0	9.41550	5.50
+10	9.41433	4.33
+20	9.41316	3.16
+30	9.41156	1.56
+40	9.41000	0.0
+50	9.40826	-1.74

Test Equipment Used: [Listed under RFI asset numbers – See Appendix 1]

M069, A388, E011, C171, RME001, RME002

Test Of: Raytheon Marine 2kW Pathfinder
SL72 (LCD Display) and SV72 (CRT Display)
To: FCC Part 80 and FCC part 2

7.7. Occupied Bandwidth

7.7.1. Plots can be found in Appendix 4.

7.7.2. The storage mode of the R&S FSM does not show internal detail of the pulse. Other analyser settings were attempted in order to obtain a more "dense" pattern. The one presented here proved to be the optimum.

7.7.3. The 99.5% power bandwidth was measured for each pulse mode using the special function option on the FSM.

Pulse Mode	99.5% Power Bandwidth, MHz
Short	44.42
Medium	21.98
Long	13.42

Test Equipment Used: [Listed under RFI asset numbers – See Appendix 1]
M072, C170, A393, A324, RME001, RME002

Test Of: Raytheon Marine 2kW Pathfinder
 SL72 (LCD Display) and SV72 (CRT Display)
 To: FCC Part 80 and FCC part 2

7.8. Transmitter Frequency Tolerance

7.8.1.Specification: 80.209 (b) – “When pulse modulation is used in land and ship radar stations operating in the bands above 2.4GHz the frequency at which maximum emission occurs must be within the authorised bandwidth and must not be closer than **1.5/T MHz** to the upper and lower limits of the authorised bandwidth where “T” is the pulse duration in microseconds.”

7.8.1.Specification Calculation

Authorised Bandwidth: 9300MHz to 9500MHz

Specification Limits [Lower] 9300 + 1.5/T
[Upper] 9500 - 1.5/T

Trransmitter Frequency Tolerances FCC ID ASLMTX2			
Pulse Width	Microseconds	Specification Limits (MHz)	
		Lower	Upper
Medium	0.252	9305.952	9494.048

From examining the transmitter frequency data from Variation of Frequency with Voltage and Variation of Frequency with Temperature results pages, it can be seen that the transmitter is within the calculated specification.

Test Of: Raytheon Marine 2kW Pathfinder
SL72 (LCD Display) and SV72 (CRT Display)
To: FCC Part 80 and FCC part 2

7.9. Suppression of Interference Aboard Ships

7.9.1. Due to the waveguide beyond cut-off action of the circulator and antenna feeder, testing of emissions at the antenna port with the system in standby mode was performed between 6GHz and 26.5GHz.

7.9.2. It should be noted that the local oscillator is switched off when the system is in standby mode. Hence little or no trace of the carrier frequency is visible on the scans.

7.9.3. Plots of the scans can be found in Appendix 4

Test Equipment Used: [Listed under RFI asset numbers – See Appendix 1]

M072, C183, M133

Test Of: Raytheon Marine 2kW Pathfinder
SL72 (LCD Display) and SV72 (CRT Display)
To: FCC Part 80 and FCC part 2

8. Measurement Uncertainty

8.1. Company Policy, as based on the NAMAS Accreditation Standard, M10, paragraph 12.11 (o), states that Test Reports shall include estimated uncertainty of the calibration or test result (this information need only appear in test reports and test certificates where it is relevant to the validity or application of the test result, where a client's instructions so require or where uncertainty affects compliance to a specification or limit).

8.2. The global uncertainties have been calculated in accordance with NAMAS NIS 81 (Edition 1, May 1994) as follows:

Measurement Type	Range	Confidence Level	Calculated Uncertainty
Radiated Emissions: Electric Field Strength	30 MHz to 1000 MHz	95%	+ 3.5 / -3.3 dB
Radiated Emissions: Electric Field Strength	1 GHz and Greater	95%	± 4.2 dB

8.3. Measurement uncertainties have been applied in accordance with NAMAS document NIS 81 (edition 1, May 1994), and in the absence of any specification criteria, guidance, or code of practice, compliance has been judged on the basis of shared risk.

8.4. In the case of emissions tests, the measured value of the disturbance from the product sample shall be compared directly with the limits. If the measured value is equal to or less than the limit the product is deemed to pass the test.

8.5. In the case of immunity tests, the equipment is deemed to pass the test if it fulfils the stated performance criteria at the required or a higher severity level. The measurement uncertainty has been taken into account in the calibration procedures stated in the relevant basic standard.

8.6. The methods used to calculate the above uncertainties are in line with those used for calibration laboratories contained in NAMAS document NIS 3003 Edition 8 "The Expression of Uncertainty and Confidence in Measurement" May 1995, which align with international recommendations "Guide to the Expression of Uncertainty in Measurement" ISO/IEC/OIML/BIPM (Prepared by ISO/TAG 4: January 1993).

Test Of: Raytheon Marine 2kW Pathfinder
SL72 (LCD Display) and SV72 (CRT Display)
To: FCC Part 80 and FCC part 2

Appendix 1. Test Equipment Used

RFI Number	Device	Manufacturer	Model No	Serial No
A023	Conical Log Spiral Antenna	EMCO	3101	3118
A024	Biconical Antenna	EMCO	3104C	3540
A026	Compressor	Airmaster	POP 8/56	10916
A027	1 to 2GHz Horn antenna	Eaton	9188-2	301
A031	2 to 4GHz Horn antenna	Eaton	91889-2	557
A201	18 to 16.5GHz Horn	FMI	20240-20	266
A202	40 to 60GHz Horn	FMI	24240-20	116
A203	26.5 to 40GHz Horn	FMI	22240-20	343
A223	Diode Detector	HP	8474B	01841
A234	Co-axial switch	RS	651-650	None
A253	4 to 6GHz Microwave horn	FMI	12240-20	128
A254	6 to 8.2GHz Horn	FMI	14240-20	139
A255	8.2 to 12.5GHz Horn	FMI	16240-20	519
A256	12.5 to 18GHz Horn	FMI	18240-20	400
A259	Bilog antenna	Chase	CBL 6111	1513
A276	OATS positioning controller	R&S	HCC	None
A277	OATS antenna mast	R&S	HCM	None
A324	10 dB coaxial attenuator	Suhner	6820.17.B	None
A331	20 dB waveguide 22 attenuator	FMI	22081-20	45
A347	Waveguide 25 100mm straight	FMI	25441	None
A348	Waveguide 27 100mm straight	FMI	27441	None
A388	20 dB coaxial attenuator	Suhner	6820.17.B	None
A393	20 dB coaxial attenuator	Suhner	6820.17.B	None
C170	3M N-type terminated cable	Rosenberger	None	None
C171	3M N-type terminated cable	Rosenberger	None	None
C181	2 metre SMA terminated cable	Rosenberger	A 3035 81 518	None
C183	2 metre SMA terminated cable	Rosenberger	UFA210A-1-0787-30X34	1039
C326	Cable	Rosenberger	UFA 210A-1-3	9600203
C327	Cable	Rosenberger	UFA 210A-1-3	96C0218

Test Of: Raytheon Marine 2kW Pathfinder
SL72 (LCD Display) and SV72 (CRT Display)
To: FCC Part 80 and FCC part 2

RFI Number	Device	Manufacturer	Model No	Serial No
E011	Environmental Chamber	DE	WIR3-40	11-96-A2103
G051	Signal Generator	Gigatronix	7100/01-20	749472
M002	Receiver	R&S	ESVP	882 402/001
M003	Spectrum monitor	R&S	EZM	881334/007
M004	Spectrum Monitor	R&S	EZM	881334/009
M023	Receiver	R&S	ESVP	872991/027
M024	Spectrum monitor	R&S	EZM	873 952/006
M029	500M sample/sec oscilloscope	Tektronix	2440	0120850
M058	Digital Multi Meter	Fluke	79	54940691
M069	Spectrum Analyser	R&S	ESMI	8/007 (DU)/827 063/00
M072	26.5GHz Spectrum Analyser	R&S	FSM	862967/010
M074	Thermometer / Humidity meter	Maplin	Precision Gold	None
M076	Harmonic Mixer Set	R&S	FS-Z16	831 337/002
M117	Temperature/humidity meter	RS	212-124	None
M122	Digital Multimeter	Fluke	77	64910017
M133	Humidity/temperature meter	RS	None	None
M150	RF Power Sensor	Boonton	51072	28754
M151	Power Meter	Boonton	4220	33402BE
RFI001	4 to 6GHz Horn	FMI	12240-20	134
RFI002	50 to 75GHz Horn	FMI	25240-20	None
RFI003	75 to 110GHz Horn	FMI	27240-20	None
RFI004	Waveguide 27 100mm straight	FMI	27000	None
RME001	40dB waveguide coupler	Mitec Europe	M0907-7-40F-11-11	2712-1 issue 1
RME002	Waveguide load	Mitec Europe	EM2190	3731-1
S013	HovAir Turntable	HovAir	None	None

NB In accordance with NAMAS requirements, all the measurement equipment is on a calibration schedule.

Test Of: Raytheon Marine 2kW Pathfinder
SL72 (LCD Display) and SV72 (CRT Display)
To: FCC Part 80 and FCC part 2

Abbreviations:

FMI:	Flann Microwave Instruments
R&S:	Rohde and Schwarz
RS:	Radio Spares Components
DE:	Design Environmental
HP:	Hewlett Packard
RFI:	Radio Frequency Investigation Ltd.
RME:	Raytheon Marine Europe Ltd

Please Note: All client supplied equipment (prefixed "RME" in the above table) was fully checked by Radio Frequency Investigation Ltd. personnel prior to use.

Test Of: Raytheon Marine 2kW Pathfinder
SL72 (LCD Display) and SV72 (CRT Display)
To: FCC Part 80 and FCC part 2

Appendix 2. Measurement Methods

A2.1. Radiated Emissions [9kHz to 1GHz]

A2.1.1. Radiated emissions measurements were performed in accordance with the standard, against appropriate limits for a Quasi-Peak detector.

A2.1.2. Initial measurements covering the entire measurement band in the form of swept scans in a shielded enclosure were performed in order to identify frequencies on which the EUT was generating interference. This determined the frequencies on which the EUT should be re-measured in full on the open area test site. In order to minimise the time taken for the swept measurements, a Peak detector was used in conjunction with the appropriate detector IF measuring bandwidth (see table below). Repetitive scans were performed to allow for emissions with low repetition rates, and for the duty cycle of the EUT. The test configuration was the same for the initial scans as for the final measurements.

A2.1.3. The initial scans were performed using an antenna height of 1.5 m and a measurement distance of 3 m. Following the initial scans, graphs were produced giving an overview of the emissions from the EUT plotted against the appropriate specification limit. A tolerance line was set 20 dB below the specification limit and levels above the tolerance line were re-tested on the open area test site, at the appropriate distance, using a measuring receiver with a Quasi-Peak detector.

A2.1.4. For the main (final) measurements the EUT was arranged on a non-conducting table on an open area test site, as detailed in the specification.

A2.1.5. All measurements on the open area test site were performed using broadband antennas.

A2.1.6. On the open area test site, at each frequency where a signal was found, the levels were maximised by initially rotating the turntable through 360° and then varying the antenna height between 1 m and 4 m. At this point, any signals found to be between the limit and a level 6 dB below it were further maximised by changing the configuration of the EUT, e.g. re-routing cables to peripherals and moving peripherals with respect to the EUT.

Test Of: Raytheon Marine 2kW Pathfinder
SL72 (LCD Display) and SV72 (CRT Display)
To: FCC Part 80 and FCC part 2

A2.2. Radiated Emissions [1GHz to 100GHz]

A2.2.1 Calculating Radiated Emissions Limit Line

In defining the 135.17dBuV/m limit for the product, the product was placed on the open area test site table with the measuring equipment located at a distance of three meters.

The 18 inch patch array antenna was fitted as representative of normal operation and the magnetron disconnected. The magnetron was replaced with a waveguide to coaxial adaptor and connected to a signal generator.

The signal generator was unable to reproduce the actual peak power output of the intentional radiator – measured as 1.45kW by conducted methods. Consequently, a level of 1.45mW was reproduced at the antenna port and the level on the spectrum analyser offset by +60dB.

The patch antenna was then connected to the transmitter system and the substitution measurement performed.

Test Of: Raytheon Marine 2kW Pathfinder
SL72 (LCD Display) and SV72 (CRT Display)
To: FCC Part 80 and FCC part 2

Appendix 3. Test Configuration Drawings

This appendix contains the following drawings:

Drawing Reference Number	Title
DRG\34964U02\EMIRAD	Test configuration for measurement of radiated electric field
DRG\34964U02\001	Diagram of the EUT and measurement antenna for frequencies above 1GHz
DRG\34964U02\002	Schematic of EUT and associated components for all conducted measurements

Test Of: Raytheon Marine 2kW Pathfinder
SL72 (LCD Display) and SV72 (CRT Display)
To: FCC Part 80 and FCC part 2

DRG134964U02EMIRAD

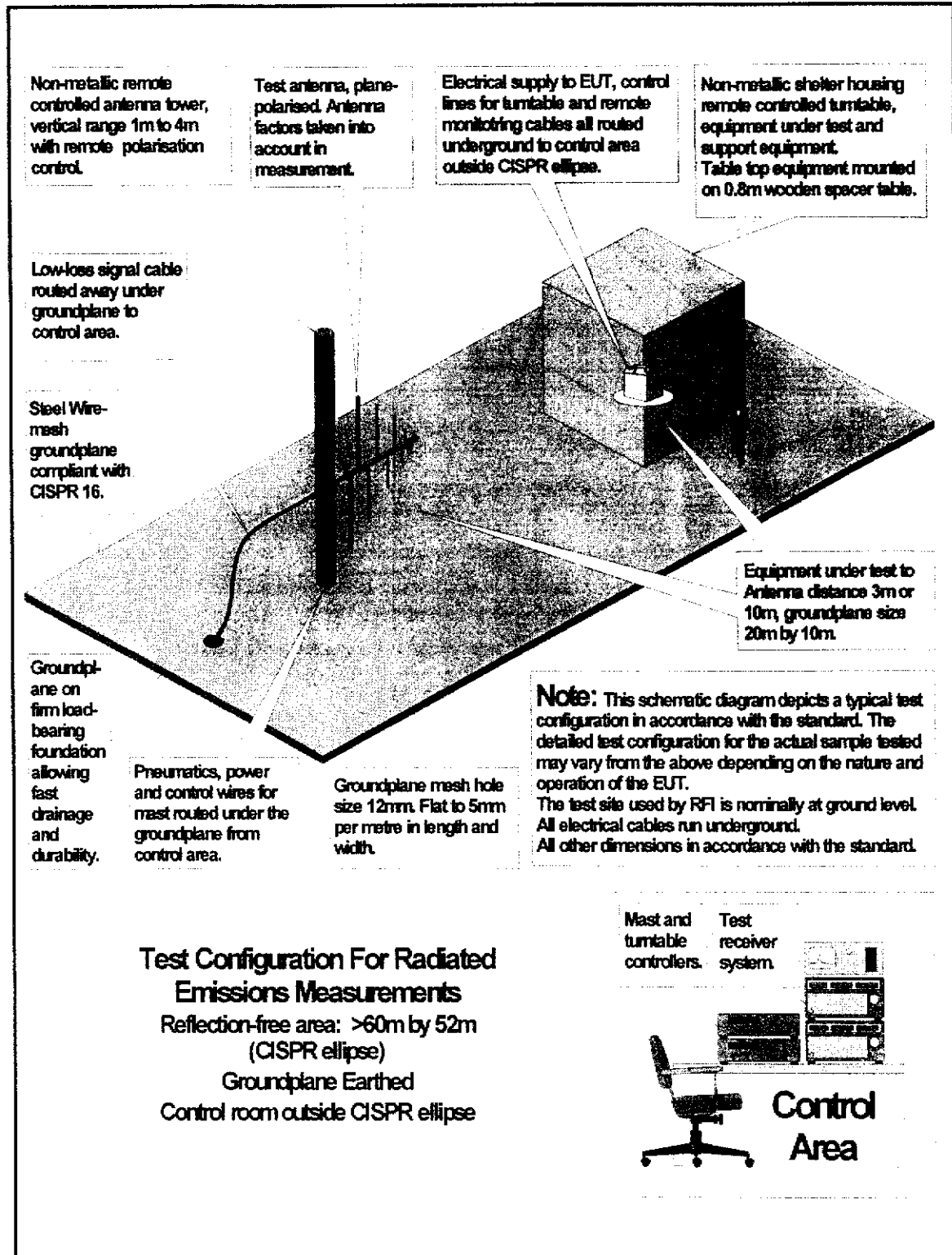

Test Of: Raytheon Marine 2kW Pathfinder
SL72 (LCD Display) and SV72 (CRT Display)

To: FCC Part 80 and FCC part 2

DRG\34964U02\001

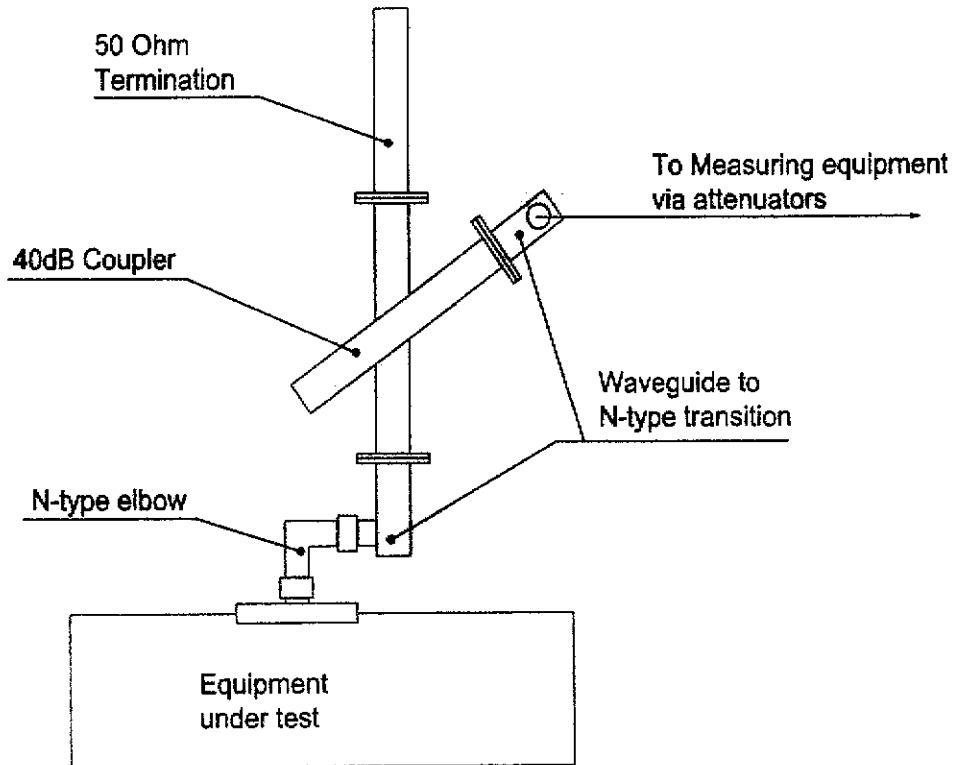

DRG\34964U02\002

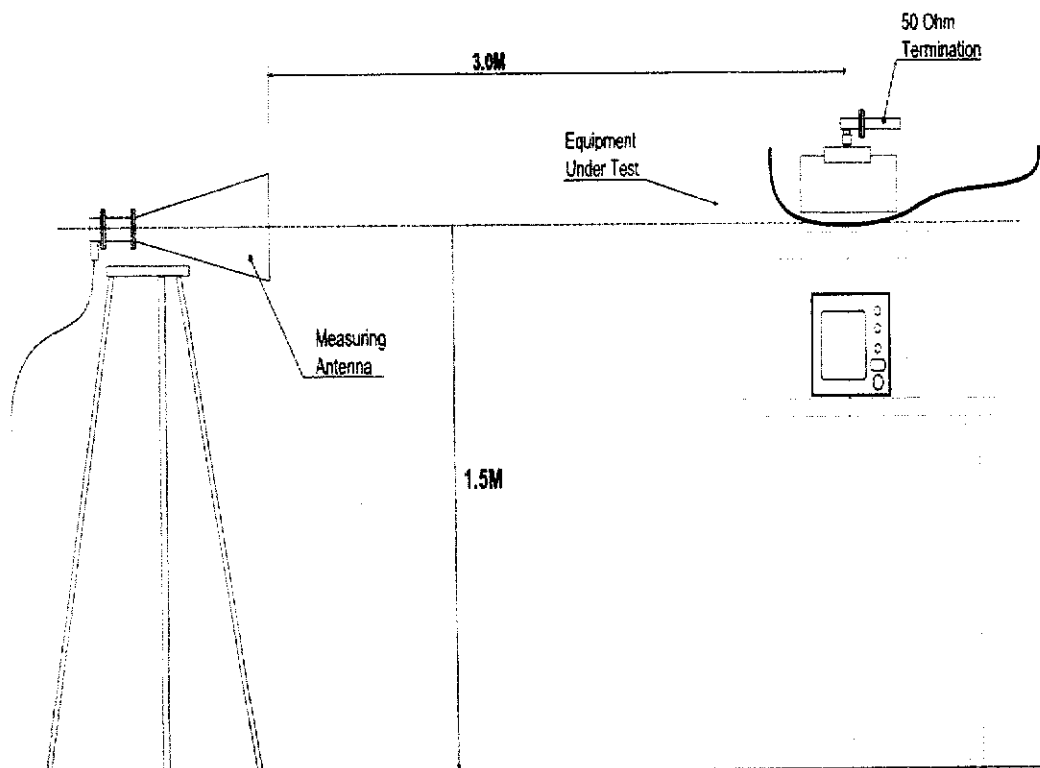

Test Of: Raytheon Marine 2kW Pathfinder
SL72 (LCD Display) and SV72 (CRT Display)

To: FCC Part 80 and FCC part 2

Appendix 4. Graphical Test Results

This appendix contains the following graphs:

Graph Reference Number	Title
GPH/35009/E01/003	Field strength of spurious radiation – 9kHz to 150kHz (CRT)
GPH/35009/E01/004	Field strength of spurious radiation – 150kHz to 30MHz (CRT)
GPH/34784/E01/001	Field strength of spurious radiation – 30MHz to 200MHz (CRT)
GPH/34784/E01/002	Field strength of spurious radiation – 200MHz to 1GHz (CRT)
GPH/35009/E01/001	Field strength of spurious radiation – 9kHz to 150kHz (LCD)
GPH/35009/E01/002	Field strength of spurious radiation – 150kHz to 30MHz (LCD)
GPH/34784/E01/004	Field strength of spurious radiation – 30MHz to 200MHz (LCD)
GPH/34784/E01/003	Field strength of spurious radiation – 200MHz to 1GHz (LCD)
GPH34964/U/01/031	Field strength of spurious radiation – 1GHz to 2GHz
GPH34964/U/01/030	Field strength of spurious radiation – 2GHz to 4GHz
GPH34964/U/01/029	Field strength of spurious radiation – 4GHz to 6GHz
GPH34964/U/01/028	Field strength of spurious radiation – 6GHz to 8.2GHz
GPH34964/U/01/018	Field strength of spurious radiation – 8.2GHz to 12.5GHz
GPH34964/U/01/019	Field strength of spurious radiation – 12.5GHz to 18GHz
GPH34964/U/01/020	Field strength of spurious radiation – 18GHz to 26.5GHz
GPH34964/U/01/021	Field strength of spurious radiation – 26.5GHz to 29GHz
GPH34964/U/01/022	Field strength of spurious radiation – 29GHz to 35GHz
GPH34964/U/01/023	Field strength of spurious radiation – 35GHz to 40GHz
GPH34964/U/01/024	Field strength of spurious radiation – 40GHz to 50GHz
GPH34964/U/01/025	Field strength of spurious radiation – 50GHz to 59GHz
GPH34964/U/01/026	Field strength of spurious radiation – 59GHz to 75GHz
GPH34964/U/01/027	Field strength of spurious radiation – 75GHz to 95GHz
GPH\34964U02\001	Occupied Bandwidth – Short pulse
GPH\34964U02\002	Occupied Bandwidth – Medium pulse
GPH\34964U02\003	Occupied Bandwidth – Long pulse
GPH\34964U02\006	Suppression of interference aboard ships – 6GHz to 16GHz
GPH\34964U02\007	Suppression of interference aboard ships – 16GHz to 26.5GHz

Test Of: Raytheon Marine 2kW Pathfinder
SL72 (LCD Display) and SV72 (CRT Display)

To: FCC Part 80 and FCC part 2

Graph Reference Number	Title
GPH\34964U02\004	Spurious emissions at antenna terminal – 9kHz to 150kHz
GPH\34964U02\005	Spurious emissions at antenna terminal – 150kHz to 30MHz
GPH\34295\01\001	Spurious emissions at antenna terminal – 30MHz to 1GHz
GPH\34295\01\002	Spurious emissions at antenna terminal – 1GHz to 8GHz
GPH\34295\01\003	Spurious emissions at antenna terminal – 8GHz to 9.31GHz
GPH\34295\01\004	Spurious emissions at antenna terminal – 9.51GHz to 13GHz
GPH\34295\01\005	Spurious emissions at antenna terminal – 13GHz to 20GHz
GPH\34295\01\006	Spurious emissions at antenna terminal – 20GHz to 26.5 GHz
GPH\34295\01\007	Spurious emissions at antenna terminal – 26.5GHz to 40GHz
GPH\34295\01\008	Spurious emissions at antenna terminal – 40GHz to 60GHz
GPH\34295\01\009	Spurious emissions at antenna terminal – 60GHz to 75GHz
GPH\34295\01\010	Spurious emissions at antenna terminal – 75GHz to 100GHz
GPH\34295\01\011	Short Pulse width – Timing Plot
GPH\34295\01\012	Medium pulse width – Timing Plot
GPH\34295\01\013	Long pulse width – Timing Plot
GPH\34295\01\014	Short pulse PRF
GPH\34295\01\015	Medium pulse PRF
GPH\34295\01\016	Long Pulse PRF
GPH\34295\01\017	85 % 10.2 Volts frequency
GPH\34295\01\018	100 % 12.0 Volts frequency
GPH\34295\01\019	100 % 24.0 Volts frequency
GPH\34295\01\020	115 % 27.6 Volts frequency

These pages are not included in the total number of pages for this report.