

UHF FM Data Transmitter and Receiver Modules

European versions: TX3A-869-64/RX3-869-64
USA versions: TX3A-914-64/RX3-914-64

The TX3A & RX3 are miniature UHF radio transmitter & receiver modules designed for PCB mounting. They allow the simple implementation of data links at speeds up to 64kbps and distances up to 30m in-building or 120m over open ground.

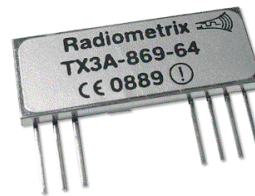

TX3A Transmitter

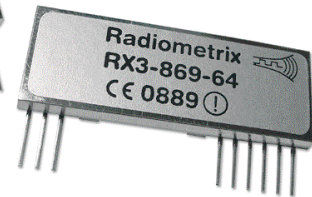

RX3 Receiver

Features:

- Frequencies available as standard: 869.85MHz, 914.5MHz
- CE certified by independent Notified Body
- Verified to comply with Radio standard EN 300 220-3 by accredited Test Laboratory
- Verified to comply with EMC standard EN 301 489-3 by accredited Test Laboratory
- North American version conforms to FCC part 15.249
- Data rates up to 64kbps
- Fully screened

Available for operation in the 868-870MHz band in Europe and the 902-928MHz band in North America, both modules combine full screening with internal filtering to ensure EMC compliance by minimising spurious radiation and susceptibility. The TX3A & RX3 will suit one-to-one and multi-node wireless links in such applications as car and building security, EPOS and inventory tracking, remote industrial process monitoring and data networks. Because of their small size and low power requirements, both modules are ideal for use in portable, battery-powered applications such as hand-held terminals.

Transmitter - TX3A

- Crystal-locked PLL, FM modulated at up to 64 kb/s
- Operation from 2.2V to 12V @ 7.5mA
- Built-in regulator for improved stability and supply noise rejection
- 1mW nominal RF output
- Enable facility
- Update of the original TX3 with enhanced performance

Receiver - RX3

- Single conversion FM superhet with SAW front end filter
- Operation from 2.7V to 12V @ 9.5mA
- Built-in regulator for improved stability and supply noise rejection
- 64kb/s, -98dBm sensitivity @ 1ppm BER
- RSSI output with 75dB range
- Enable facility

Functional description

The TX3A transmitter module uses a frequency modulated crystal-locked PLL and operates between 2.2V and 12V at a current of 7.5mA nominal. At 3V supply it delivers nominally 0dBm (1mW) RF output. The SIL style TX3A measures 32 x 12 x 3.8 mm, excluding pins.

The RX3 module is a single conversion FM superhet receiver capable of handling data rates of up to 64kb/s. It will operate from a supply of 2.7V to 12V and draws 9.5mA when receiving. The RX3 features a fast power-up time for effective duty cycle power saving and a signal strength (RSSI) output with 75dB of range. Full screening and a SAW front-end filter give good immunity to interference. The SIL style RX3 measures 48 x 17.5 x 4.5 mm, excluding pins.

TX3A transmitter

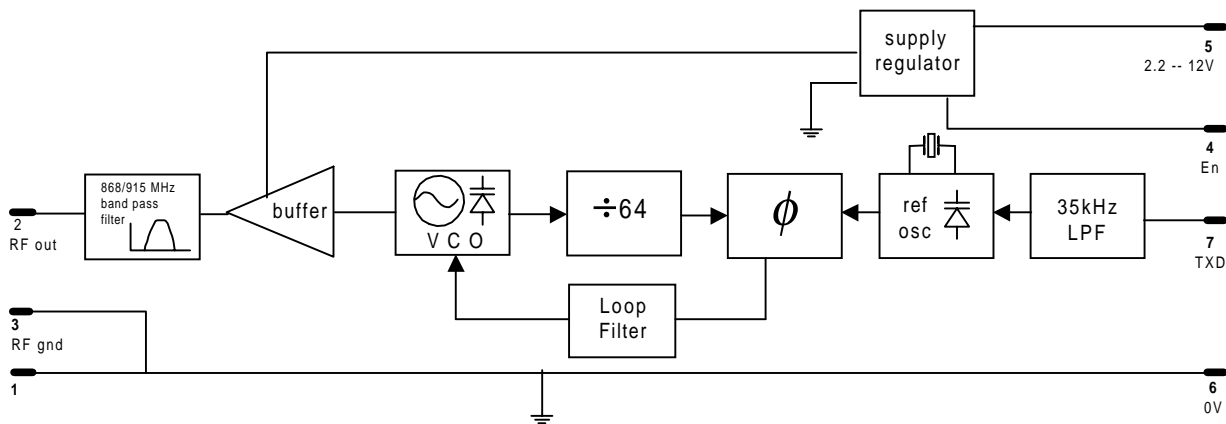

Fig 1:TX3A block diagram

Pin description

RF GND (pins 1&3)

RF ground, internally connected to the module screen and pin 6 (0V). These pins should be directly connected to the RF return path - e.g. coax braid, main PCB ground plane etc.

RF OUT (pin 2)

50Ω RF output to the antenna. Internally DC-isolated. See antenna section of apps notes for details of suitable antennas.

En (pin 4)

Tx enable. <0.15V shuts down module (current <1μA). >1.7V enables the transmitter. Impedance ~1MΩ. Observe slew rate requirements (see apps notes).

Vcc (pin 5)

+2.2V to +12V DC supply. Max ripple content 0.1V_{P-P}. Decoupling is not generally required.

0V (pin 6)

DC supply ground. Internally connected to pins 1 & 3 and module screen.

TXD (pin 7)

DC-coupled modulation input. Accepts serial digital data at 0V to 2.5V levels. See applications notes for suggested drive methods. Input is high impedance (>1MΩ).

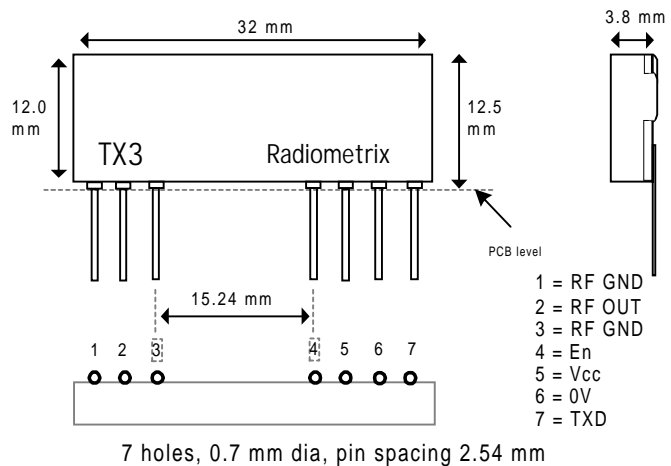

Fig2: TX3A physical dimensions

RX3 receiver

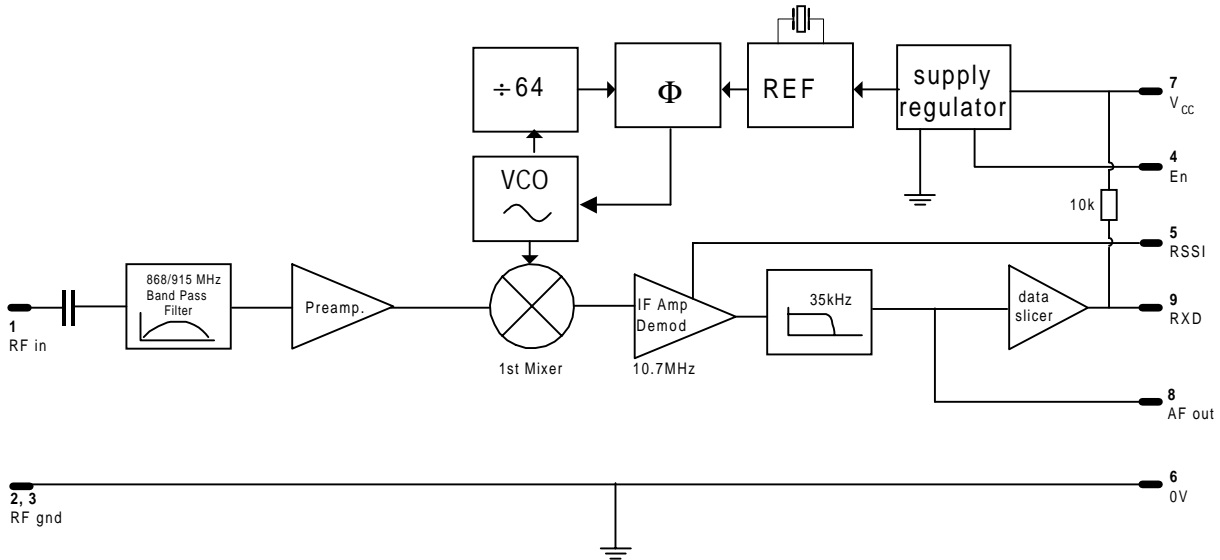

Fig.3: RX3 block diagram

Pin description

RF IN (pin 1)

50Ω RF input from antenna. Internally DC-isolated. See antenna section of applications notes for suggested antennas and feeds.

RF GND (pins 2 & 3)

RF ground, internally connected to the module screen and pin 6 (0V). These pins should be connected to the RF return path - e.g. coax braid, main PCB ground plane etc.

En (pin 4)

Rx enable. <0.15V shuts down module (current <1μA). >1.7V enables the receiver. Impedance ~1MΩ. Observe slew rate requirements (see apps notes).

RSSI (pin 5)

Received signal strength indicator with >65dB range. See applications notes for typical characteristics.

0V (pin 6)

DC supply ground. Internally connected to pins 2 & 3 and module screen.

Vcc (pin 7)

+2.7V to +12V DC supply. Max ripple content 0.1V_{P-P}. Decoupling is not generally required.

AF out (pin 8)

Buffered and filtered analogue output from the FM demodulator. Standing DC bias 1.3V approx. External load should be >50kΩ // <100pF. **NOTE:** AF waveform from this pin is **inverted**.

RXD (pin 9)

Digital output from the internal data slicer. The data is true data, i.e. as fed to the transmitter. Output is "open-collector" format with internal 10kΩ pull-up to Vcc (pin 7).

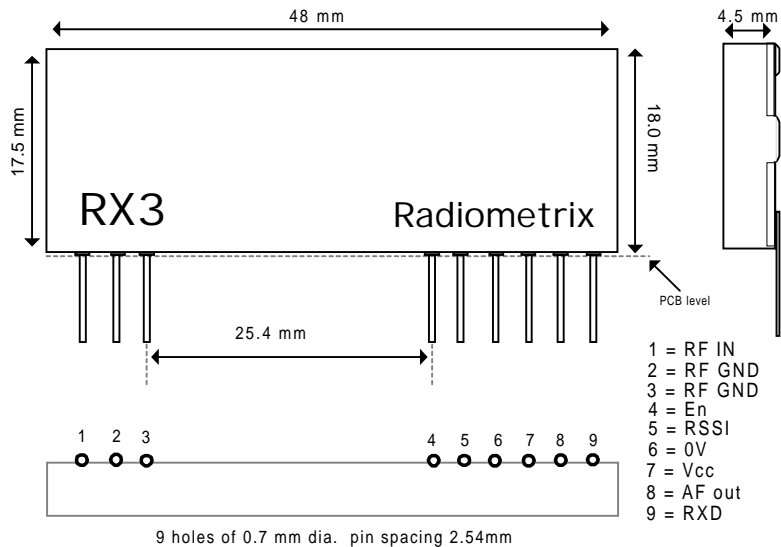

Fig.4: RX3 physical dimensions

Absolute maximum ratings

Exceeding the values given below may cause permanent damage to the module.

Operating temperature	-20°C to +70°C
Storage temperature	-40°C to +100°C

TX3A

Vcc (pin 5)	-0.3V to +16V
TXD (pin 7)	±7V
En (pin 4)	-0.3V to +Vcc V
RF OUT (pin 2)	±50V DC, +10dBm RF

RX3

RSSI, Vcc, RXD (pins 5,7,9)	-0.3V to +16V
En, AF (pins 4,8)	-0.3V to +Vcc V
RF IN (pin 1)	±50V DC, +10dBm RF

Performance specifications: TX3A transmitter
(Vcc = 3.0V / temperature = 20°C unless stated)

	pin	min.	typ.	max.	units	notes
DC supply						
Supply voltage	5	2.2	3.0	12	V	1,6
Supply current	5		7.5	9.5	mA	2
RF						
RF power output @ Vcc = 2.2V	2		-1		dBm	2
RF power output @ Vcc ≥ 2.8V	2		0		dBm	2
Harmonics / spurious emissions	2		-55	-45	dBc	3
Initial frequency accuracy		-25	0	+25	kHz	
FM deviation (peak)			±27		kHz	4
Baseband						
Modulation bandwidth @ -3dB		0		35	kHz	
Modulation distortion (THD)			5	10	%	6
TXD input level (logic low)	7	-0.2	0	+0.2	V	5,6
TXD input level (logic high)	7	+2.3	+2.5	+3	V	5,6
Dynamic timing						
Power-up time (En → full RF)			1.0	1.5	ms	

Notes:

1. RF output is automatically disabled below 2.2V supply voltage.
2. RF output terminated with 50Ω resistive load.
3. Meets or exceeds EN/FCC requirements at all frequencies.
4. With 0V – 2.5V modulation input.
5. To achieve specified FM deviation.
6. See applications information for further details.

Performance specifications: RX3 receiver
(Vcc = 3.0V / temperature = 20°C unless stated)

	pin	min.	typ.	max.	units	notes
DC supply						
Supply voltage	7	2.7	3.0	12	V	
Supply current	7		9.5	11	mA	
RF/IF						
RF sensitivity @ 10dB (S+N)/N	1,8		-103	-97	dBm	
RF sensitivity @ 1ppm BER	1,9		-98	-92	dBm	
IP ₃ at RF input	1		-14.5		dBm	
Max operational RF input	1		-10		dBm	1
RSSI threshold	1,5		-115		dBm	1
RSSI range	1,5	65	75		dB	1
IF bandwidth			180		kHz	
Image rejection	1	40	45		dB	
½-IF spurious rejection	1		50		dB	
±1MHz spurious rejection	1		67		dB	
LO leakage, conducted	1		-75	-70	dBm	2
Baseband						
Baseband bandwidth @ -3dB	8	0		35	kHz	
AF level	8		200		mV _{P-P}	3,4
DC offset on AF out	8	0.9	1.3	1.7	V	
Distortion on recovered AF	8		1	5	%	
Load capacitance, AFout / RXD	8,9			100	pF	
Dynamic timing						
<i>Power up with signal present</i>						
Power up to valid RSSI	4,5		5.5	7	ms	
Power up to stable data	4,9		15	18	ms	5
<i>Signal applied with supply on</i>						
Signal to valid RSSI	1,5		1.6	2	ms	
Signal to stable data	1,9		1	10	ms	6
Time between data transitions	9	15.6		1250	µs	7
Mark : space ratio	9	20	50	80	%	8

Notes:

1. See applications information for further details.
2. Meets or exceeds EN/FCC requirements at all frequencies.
3. For received signal with ±27kHz FM deviation.
4. AF waveform on pin 8 is inverted.
5. 50kHz offset. Typically 5ms for on-channel signal.
6. Typically 1ms for on-channel signal, 10ms for 50kHz offset.
7. For 50:50 mark to space ratio (i.e. squarewave).
8. Average over 50ms period at maximum bit rate.

Module test circuits

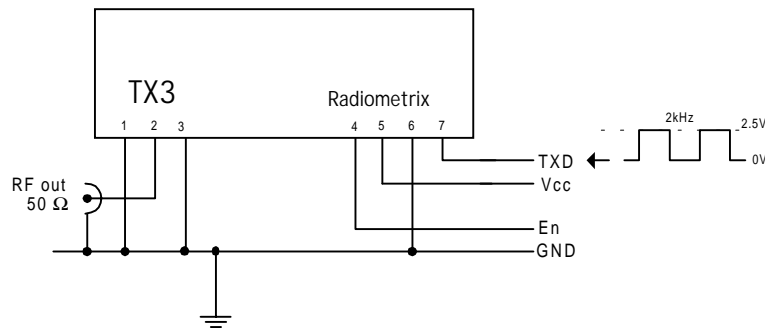

Fig.5: TX3A test circuit

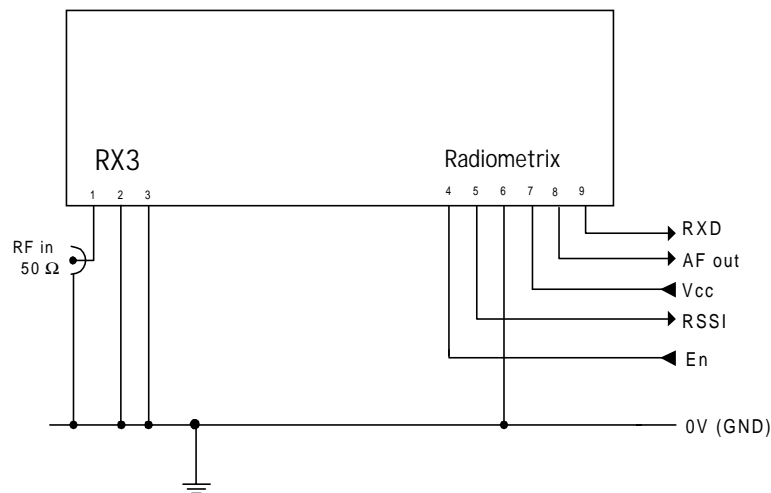

Fig.6: RX3 test circuit

Applications information

Power supply requirements

Both modules incorporate a built-in regulator which delivers a constant 2.85V to the module circuitry when the external supply voltage is 2.9V or greater, with 40dB or more of supply ripple rejection. This ensures constant performance up to the maximum permitted supply rail and removes the need for external supply decoupling except in cases where the supply rail is extremely poor (ripple/noise content $>0.1V_{p-p}$).

Note, however, that for supply voltages lower than 2.85V the regulator is effectively inoperative and supply ripple rejection is considerably reduced. Under these conditions the ripple/noise on the supply rail should be below $10mV_{p-p}$ to avoid problems. If the quality of the supply is in doubt, it is recommended that a $10\mu F$ low-ESR tantalum or similar capacitor be added between the module supply pin (Vcc) and ground, together with a 10Ω series feed resistor between the Vcc pin and the supply rail.

The Enable pin allows the module to be turned on or off under logic control with a constant DC supply to the Vcc pin. The module current in power-down mode is less than $1\mu A$.

NOTE: If this facility is used, the logic control signal must have a slew rate of $40mV/\mu s$ or more. Slew rates less than this value may cause erratic operation of the on-board regulator and therefore the module itself.

The TX3A incorporates a low voltage shutoff circuit which prevents any possibility of erratic operation by disabling the RF output if the supply voltage drops below 2.2V ($\pm 5\%$). This feature is self-resetting, i.e. restoring the supply to greater than 2.2V will immediately restore full RF output from the module.

TX3A modulation requirements

The module will produce the specified FM deviation with a TXD input to pin 7 of 2.5V amplitude, i.e. 0V “low”, 2.5V “high”. Reducing the amplitude of the data input from this value (usually as a result of reducing the supply voltage) reduces the transmitted FM deviation to typically $\pm 22\text{kHz}$ at the lower extreme of 2.2V. The receiver will cope with this quite happily and no significant degradation of link performance should be observed as a result.

Where standard 2-level digital data is employed with a logic “low” level of $0\text{V} \pm 0.2\text{V}$, the logic “high” level applied to TXD may be any value between +2.5V and +3V for correct operation. However, if using multi-level or analogue signalling the maximum positive excursion of the modulation applied to TXD must not exceed +2.5V or waveform distortion will result. If the input waveform exceeds this level a resistive potential divider should be used at the TXD input to reduce the waveform amplitude accordingly. This input is high impedance ($>1\text{M}\Omega$) and can usually be ignored when calculating required resistor values.

Data formats and range extension

The TX3A data input is normally driven directly by logic levels but will also accept analogue drive (e.g. 2-tone signalling). In this case it is recommended that TXD (pin 7) be DC-biased to 1.25V with the modulation ac-coupled and limited to a maximum of $2.5\text{V}_{\text{p-p}}$ to minimise distortion over the link. The varactor modulator in the TX3A introduces some 2nd harmonic distortion which may be reduced if necessary by predistortion of the analogue waveform. At the other end of the link the RX3 AF output is used to drive an external decoder directly.

Although the modulation bandwidth of the TX3A extends down to DC, as does the AF output of the RX3, it is not advisable to use data containing a DC component. This is because frequency errors and drifts between the transmitter and receiver occur in normal operation, resulting in DC offset errors on the RX3 audio output.

The RX3 incorporates a low pass filter which works in conjunction with similar filtering in the TX3 to obtain an overall system bandwidth of 32kHz. This is suitable for transmission of data at raw bit rates up to 64kb/s. The adaptive data slicer in the RX3 has been designed to accept a maximum time between data transitions of 1.25ms, in order to keep settling times reasonably fast. It will function reliably down to a bit rate of approximately 1kb/s, assuming the code in use contains no long 1s or 0s (i.e. Manchester or similar).

RXD output on pin 9 of the RX3 is “true” sense, i.e. as originally fed to the transmitter.

In applications such as longer range fixed links where data speed is not of primary importance, a significant increase in range can be obtained by using the slowest possible data rate together with filtering to reduce the receiver bandwidth to the minimum necessary. Because of the limitations of the internal data slicer, in these circumstances the RX3 audio output should be used to drive an external filter and data slicer.

The audio output waveform on pin 8 of the RX3 is inverted, i.e. in the opposite sense to that originally fed to the transmitter. This should be borne in mind if using the RX3 AF output to drive other circuitry.

RX3 Received Signal Strength Indicator (RSSI)

The RX3 receiver incorporates a wide range RSSI which measures the strength of an incoming signal over a range of 60dB or more. This allows assessment of link quality and available margin and is useful when performing range tests.

The output on pin 5 of the module has a standing DC bias of typically 0.25V with no signal, rising to 1V at maximum indication. The RSSI output source impedance is high (~20k Ω) and external loading should therefore be kept to a minimum.

Typical RSSI characteristic is as shown below:

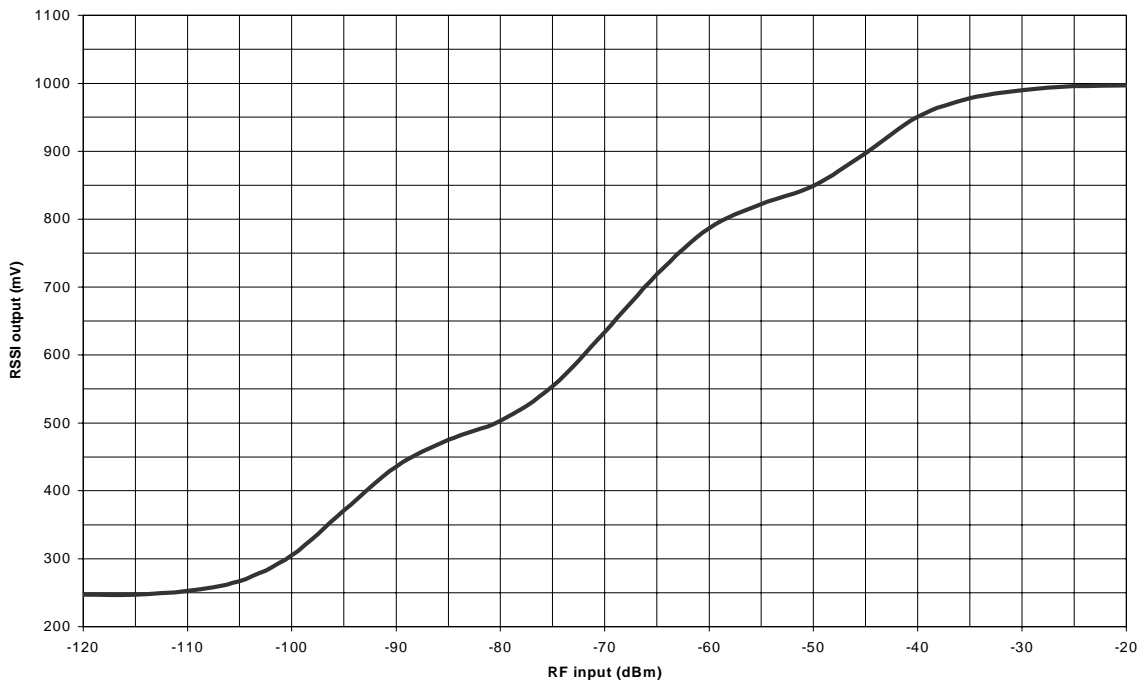

Fig. 7: RX3 RSSI response curve

To ensure a reasonably fast response the RSSI has limited internal decoupling of 10nF to ground. This results in a small amount of audio ripple on the DC output at pin 5 of the module. If this is a problem further decoupling may be added at the expense of response speed, in the form of a capacitor from pin 5 to ground. There is no upper limit on the value of this capacitor.

Operating the RX3 and TX3A in close proximity

The RX3 receiver will start to overload if the on-frequency RF input level exceeds -10dBm, with resultant degradation in performance. It is sometimes possible to exceed this level if operating the TX3A in very close proximity to the RX3, particularly if using efficient antennas. It follows that if the TX3A and RX3 are combined in a transceiver arrangement, they should be operated in half-duplex mode if overload problems are to be avoided (i.e. only the transmitter or receiver should be active at any one time).

Expected range

Predicting the range obtainable in any given situation is notoriously difficult since there are many factors involved. The main ones to consider are as follows:

- Type and location of antennas in use (see below)
- Type of terrain and degree of obstruction of the link path
- Sources of interference affecting the receiver
- “Dead” spots caused by signal reflections from nearby conductive objects
- Data rate and degree of filtering employed (see page 7)

Assuming the maximum 64kb/s data rate and $\frac{1}{4}$ -wave whip antennas on both transmitter and receiver, the following ranges may be used as a rough guide only:

- | | | |
|---|---|-------------|
| 1) Cluttered/obstructed environment, e.g. inside a building | : | 30m |
| 2) Open, relatively unobstructed environment | : | 120m |

It must be stressed, however, that range could be much greater or much less than these figures. Range tests should ***always*** be performed before assuming that a particular range can be achieved in any given application.

Antenna considerations and options

The choice and positioning of transmitter and receiver antennas is of the utmost importance and is the single most significant factor in determining system range. The following notes apply particularly to integral antennas and are intended to assist the user in choosing the most effective arrangement for a given application.

Nearby conducting objects such as a PCB or battery can cause detuning or screening of the antenna which severely reduces efficiency. Ideally the antenna should stick out from the top of the product and be entirely in the clear, however this is often not desirable for practical/ergonomic reasons and a compromise may need to be reached. If an internal antenna must be used try to keep it away from other metal components and pay particular attention to the “hot” end (i.e. the far end), as this is generally the most susceptible to detuning. The space around the antenna is as important as the antenna itself.

Microprocessors and microcontrollers tend to radiate significant amounts of radio frequency hash, which can cause desensitisation of the receiver if its antenna is in close proximity. 900MHz is generally less prone to this effect than lower frequencies, but problems can still arise. Things become worse as logic speeds increase, because fast logic edges are capable of generating harmonics across the UHF range which are then radiated effectively by the PCB tracking. In extreme cases system range can be reduced by a factor of 3 or more. To minimise any adverse effects, situate the antenna and module as far as possible from any such circuitry and keep PCB track lengths to the minimum possible. A ground plane can be highly effective in cutting radiated interference and its use is strongly recommended.

A simple test for interference is to monitor the receiver RSSI output voltage, which should be the same regardless of whether the microcontroller or other logic circuitry is running or in reset.

Depending on the application and bearing in mind applicable legal requirements (see p.11), a variety of antenna types may be used with the TX3A and RX3.

Integral antennas generally do not perform as well as externally mounted types, however they result in physically compact equipment and are the preferred choice for portable applications. The following can be recommended:

Whip (1/4-wave). This consists simply of a piece of wire or rod connected to the module at one end. The lengths given below are from module pin to antenna tip including any interconnecting wire or tracking. This antenna is quite simple and performs well, especially if used in conjunction with a ground plane. This will often be provided by the PCB on which the module is mounted, or by a metal case.

Base-loaded whip. This is a shortened whip, tuned by means of a coil inserted at the base. This coil may be air-wound for maximum efficiency, or a small SMT inductor can be used if space is at a premium. The value must be carefully chosen to tune the particular length of whip in use, making this antenna more difficult to set up than a 1/4-wave whip.

Helical. This is a compact but slightly less effective antenna formed from a coil of wire. It is very efficient for its size, but has high Q and tends to suffer badly from detuning caused by proximity to nearby conductive objects. It needs to be carefully trimmed for best performance in a given situation and the required dimensional tolerances can be difficult to achieve repeatably, nevertheless it can provide a very compact solution.

Loop. A loop of PCB track, tuned and matched with 2 capacitors. Loops are relatively inefficient but have good immunity to proximity detuning, so may be preferred in shorter range applications where very high component packing density is necessary.

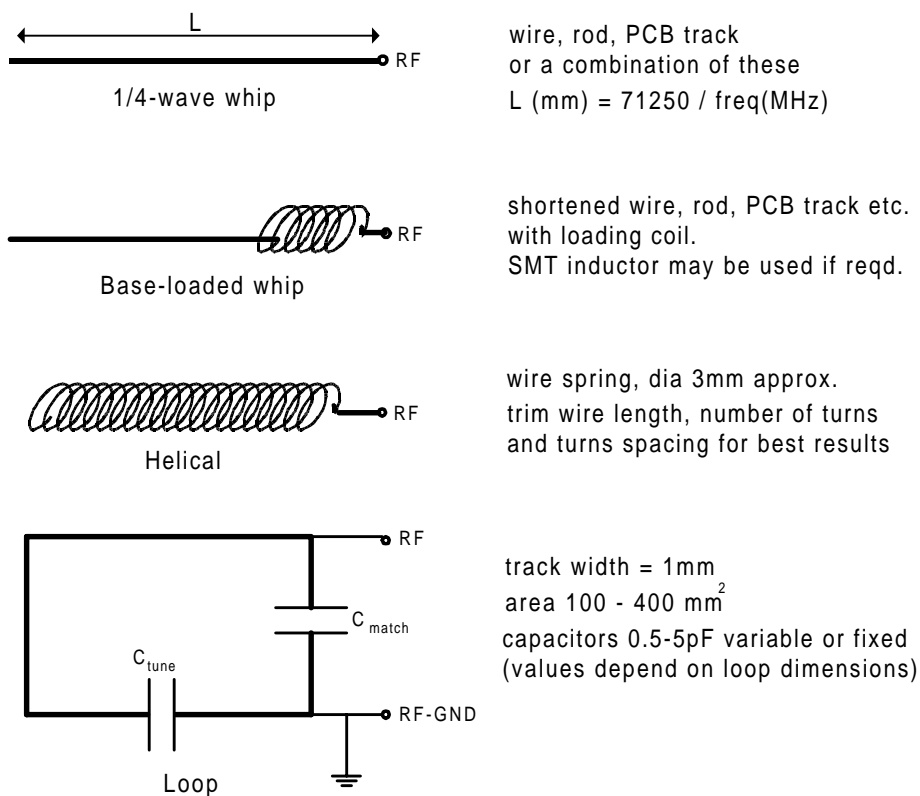

Fig.8: Integral antenna configurations

Integral antenna summary:

	whip	loaded whip	helical	loop
Ultimate performance	***	**	**	*
Ease of design set-up	***	**	*	*
Size	*	***	***	**
Immunity to proximity effects	**	*	*	***

External antennas have several advantages if portability is not an issue. They can be optimised for individual circumstances and may be mounted in relatively good RF locations away from sources of interference, being connected to the equipment by coax feeder. Apart from the usual whips, helicals etc, low-profile types such as microstrip patches can be very effective at these frequencies. Suitable antennas are available from many different sources and are generally supplied pre-tuned to the required frequency.

Type Approval requirements: Europe

The modules are verified to comply with European harmonised standard EN 300 220-3 and EMC standard EN 301 489-3 by United Kingdom Accreditation Service (UKAS) accredited Test Laboratory. The modules are CE Certified by independent Notified Body. The following provisos apply:

- 1) The modules must not be modified or used outside their specification limits.
- 2) The modules may only be used to transfer digital or digitised data. Analogue speech and/or music are not permitted.
- 3) The TX3A must not be used with gain antennas such as multi-element Yagi arrays, since this may result in allowed ERP or spurious emission levels being exceeded.
- 4) Final product incorporating the TX3A/RX3 should itself meet the essential requirement of the R&TTE Directive and a CE marking should be affixed on the final product.

Type Approval requirements: USA

Radiometrix TX3A & RX3 modules are sold as component devices which require external components and connections to function. They are designed to comply with FCC Part 15.249 regulations, however they are not approved by the FCC. The purchaser understands that FCC approval will be required prior to the sale or operation of any device containing these modules.

- 1) Antennas must be either permanently attached (i.e. non-removable) or must use a connector which is unique or not commonly available to the public.
- 2) The user must ensure that the TX3A/antenna combination does not radiate more than the maximum permitted level of 50mV/m at 3m distance (FCC Part 15.249).
- 3) The appropriate FCC identifying mark and/or part 15 compliance statement must be clearly visible on the outside of the equipment containing the module(s).

Module mounting considerations

The modules may be mounted vertically or bent horizontal to the motherboard. Good RF layout practice should be observed – in particular, any ground return required by the antenna or feed should be connected directly to the RF GND pins at the antenna end of the module, and not to the OV pin which is intended as a DC ground only. All connecting tracks should be kept as short as possible to avoid any problems with stray RF pickup.

If the connection between module and antenna does not form part of the antenna itself, it should be made using 50Ω microstrip line or coax or a combination of both. It is desirable (but not essential) to fill all unused PCB area around the module with ground plane.

Variants and ordering information

The TX3A transmitter and RX3 receiver modules are manufactured in the following variants as standard:

*For European applications in the 868-870MHz band:
Frequency = 869.85MHz*

TX3A-869-64	Transmitter
RX3-869-64	Receiver

*For USA applications in the 902-928MHz band:
Frequency = 914.5MHz*

TX3A-914-64	Transmitter
RX3-914-64	Receiver

Other variants can be supplied to customer requirements, at different frequencies and/or optimised for specific data speeds and formats. Please consult the factory for further information.

CE Certificate for TX3A



Radio Frequency Investigation Ltd

NOTIFIED BODY OPINION RFI/NBCB1/42627JD04

Applicants Details

Applicant's Company Name: Radiometrix Ltd
Address: Hartcran House, Gibbs Couch, Carpenters Park, Watford, Herts.,
WD1 5EZ
Contact Name: Mr S. Paramanathan

Manufacturers Details

Manufacturer's Company Name: Radiometrix Ltd
Address: Hartcran House, Gibbs Couch, Carpenters Park, Watford, Herts.,
WD1 5EZ
Contact Name: Mr S. Paramanathan

Product Details

Product Name: TX3A-869
Model Number(s): TX3A-869
TCF Reference Number: RM/TX3A/DTD
Standard(s): EN 300 220-1 V1.3.1 (2000-09) according to the requirements of EN
300 220-3 V1.1.1 (2000-09)
Description: UHF FM Data Transmitter Module

In the opinion of RFI, the Technical Construction File demonstrates that the Apparatus to which it relates conforms to the essential requirements of Article 3.2 of Council Directive 1999/5/EC on radio equipment and telecommunications terminal equipment and the mutual recognition of their conformity. The Apparatus can only be used with a quarter wavelength whip antenna.

Authorised Signatory:

A handwritten signature in black ink, appearing to read 'N Cobb', is written over a horizontal line.

Mr N Cobb

16-10-01

Date



Notified Body Number - 0889
Radio Frequency Investigation Ltd, Ewhurst Park, Ramsdell, Basingstoke, Hampshire RG26 5RQ, ENGLAND
Tel: +44 (0) 1256 851193 Fax: +44 (0) 1256 851192 E-mail: sales@rfi.co.uk
Registered in England, No. 211 7901

Company Seal

CE Certificate for RX3



Radio Frequency Investigation Ltd

NOTIFIED BODY OPINION RFI/NBCB1/RP42627JD05

Applicants Details

Applicant's Company Name: Radiometrix Ltd
Address: Hartcran House, Gibbs Couch, Carpenters Park, Watford, Herts.
WD1 5EZ
Contact Name: Mr S. Paramanathan

Manufacturers Details

Manufacturer's Company Name: Radiometrix Ltd
Address: Hartcran House, Gibbs Couch, Carpenters Park, Watford, Herts.
WD1 5EZ
Contact Name: Mr S. Paramanathan

Product Details

Product Name: RX3-869
Model Number(s): RX3-869-64
TCF Reference Number: RM/RX3/DTD
Standard(s): EN 300 220-1 V1.3.1 (2000-09) according to the requirements of EN
300 220-3 V1.1.1 (2000-09)
Description: UHF FM Data Receiver Module

In the opinion of RFI, the Technical Construction File demonstrates that the Apparatus to which it relates conforms to the essential requirements of Article 3.2 of Council Directive 1999/5/EC on radio equipment and telecommunications terminal equipment and the mutual recognition of their conformity.

Authorised Signatory:

A handwritten signature in black ink, appearing to read 'N Cobb', is written over a horizontal line.

Mr N Cobb

16-10-01

Date



Company Seal

Notified Body Number - 0889

Radio Frequency Investigation Ltd, Ewellurst Park, Ramsdell, Basingstoke, Hampshire RG26 5RQ, ENGLAND
Tel: +44 (0) 1256 851193 Fax: +44 (0) 1256 851192 E-mail: sales@rfi.co.uk
Registered in England, No. 211 7901

Radiometrix Ltd

Hartcran House

Gibbs Couch

Watford

WD19 5EZ

ENGLAND

Tel: +44 (0)20 8428 1220

Fax: +44 (0)20 8428 1221

info@radiometrix.co.uk

www.radiometrix.co.uk

Copyright notice

This product data sheet is the original work and copyrighted property of Radiometrix Ltd. Reproduction in whole or in part must give clear acknowledgement to the copyright owner.

Limitation of liability

The information furnished by Radiometrix Ltd is believed to be accurate and reliable. Radiometrix Ltd reserves the right to make changes or improvements in the design, specification or manufacture of its subassembly products without notice. Radiometrix Ltd does not assume any liability arising from the application or use of any product or circuit described herein, nor for any infringements of patents or other rights of third parties which may result from the use of its products. This data sheet neither states nor implies warranty of any kind, including fitness for any particular application. These radio devices may be subject to radio interference and may not function as intended if interference is present. We do NOT recommend their use for life critical applications.

The Intrastat commodity code for all our modules is: 8542 6000

R&TTE Directive

After 7 April 2001 the manufacturer can only place finished product on the market under the provisions of the R&TTE Directive. Equipment within the scope of the R&TTE Directive may demonstrate compliance to the essential requirements specified in Article 3 of the Directive, as appropriate to the particular equipment.

Further details are available on Radiocommunications Agency (RA) web site:

<http://www.radio.gov.uk/topics/conformity/conform-index.htm>

The Library and Information Service

The Radiocommunications Agency

Wyndham House

189 Marsh Wall

London

United Kingdom

E14 9SX

Tel: +44 (0)20 7211 0502/0505

Fax: +44 (0)20 7211 0507

library@ra.gsi.gov.uk

For further information on radio matters

contact the Agency's 24 Hour Telephone

Enquiry Point: +44 (0)20 7211 0211

European Radiocommunications Office (ERO)

Midtermolen 1

DK 2100 Copenhagen

Denmark

Tel. +45 35250300

Fax +45 35250330

ero@ero.dk

www.ero.dk