





Raymarine UK Ltd  
 Marine House  
 Cartwright Drive  
 Segensworth  
 Fareham  
 Hampshire  
 PO15 5RJ  
 Tel: 01329 246700

Email: [compliance@raymarine.com](mailto:compliance@raymarine.com)

<http://www.raymarine.com>

**Test Report for a65, a67 Marine Multifunction Displays**

**To 47 CFR Part 15 Subpart C and RSS 210**

Model Number	E70162, E70163, E70201		
Product Description	a65 WiFi, a67 WiFi and a68 WiFi Marine Multifunction Displays		
Report Number	TP/808/1066a		
Report Author Mike Thompson EMC Engineer		Date	5 <sup>th</sup> August 2013
Approval Andrew Little Compliance Manager		Date	5 <sup>th</sup> August 2013

Test Date Range	26 <sup>th</sup> Nov 2012 to 28 <sup>th</sup> Jan 2013 9 <sup>th</sup> and 10 <sup>th</sup> July 2013 (a68)
-----------------	--

Product Status	<b>PASS</b>
----------------	-------------

This test report shall not be reproduced except in full, without written approval of Raymarine UK Ltd.

The test data and results contained within this report relate only to the items tested.

**1 47 CFR Part 15 and RSS-210 Test Summary**

	CFR 47 Part 15	RSS-210	Section	Result
Hopping Sequence	15.247(a)		5.4	Pass
Peak Output Power	15.247(b)	A8.4(2)	5.3	Pass
Carrier Frequency Separation	15.247(a)	A8.1(b)	5.4	Pass
Frequency Band Edges	15.247(d)		5.8	Pass
20dB Bandwidth	15.247(a)(1)	A8.1(a)	5.7	Pass
Radiated Emissions	15.209(a)	RSS-GEN 7.5.2	5.11	Pass
Spurious Emissions	15.247(d)	A8.5	5.11	Pass
Number of Channels	15,247(a)(1)	A8.1(d)	5.4	Pass
Directional antenna with >6dBi	15.247(c)		5.2 Antenna<6dBi	N/A
Dwell Time	15.247(a)	A8.1(d)	5.4	Pass
6dB Bandwidth		A8.2(a)	5.9	Pass
Power Spectral Density		A8.2(b)	5.10	Pass

## 2 Attestations

This equipment has been tested in accordance with the standards identified in this report. To the best of *my* knowledge and belief, these tests were performed using the measurement procedures described in these reports.

All measuring instruments used to determine the status of the product's compliance to the identified standards are calibrated regularly in accordance with UKAS requirements.

A comprehensive system of traceable calibration in accordance with ISO9001 is maintained.

Name/Position	Signature	Date
Mike Thompson EMC Engineer		5 <sup>th</sup> August 2013

I attest that the necessary measurements were made, under my supervision at:

Raymarine UK Ltd, Marine House,  
Cartwright Drive, Segensworth,  
Fareham, Hampshire, PO15 5RJ



Andy Little  
Compliance Manager

**Date: 5<sup>th</sup> August 2013**

TABLE OF CONTENTS

1 47 CFR Part 15 and RSS-210 Test Summary ..... 2

2 Attestations ..... 3

3 Test Information ..... 5

    3.1 Test Facilities ..... 5

    3.2 Overall Test Conditions ..... 5

    3.3 Test Methods ..... 5

4 EUT Information ..... 6

    4.1 Test Rationale ..... 6

    4.2 Description of Equipment under Test (EUT) ..... 6

    4.3 Additional information ..... 7

    4.4 Description of Auxiliary Equipment ..... 8

    4.5 Test Configurations ..... 9

    4.6 Operating Modes ..... 9

5 Test Results ..... 10

    5.1 Transmit Duty Cycle, “x” ..... 10

    5.2 UUT Antenna Gain, “G” ..... 10

    5.3 Peak Output Power ..... 11

    5.4 Frequency Hopping Requirements ..... 12

    5.5 Frequency Range ..... 13

    5.6 Medium Access Protocol ..... 14

    5.7 20dB Channel Bandwidth ..... 15

    5.8 Frequency Band Edges ..... 18

    5.9 6dB Channel Bandwidth (RSS-210) ..... 18

    5.10 Power Spectral Density (RSS-210) ..... 19

    5.11 Transmitter Spurious Emissions ..... 20

    5.12 Receiver Spurious Emissions ..... 36

6 List of Test Equipment ..... 37

### 3 Test Information

#### 3.1 Test Facilities

Site 1	9m x 6m x 5.5m Semi Anechoic Chamber	FCC ID IC Certification	Reg 371673 Reg 4069B-2
--------	---	----------------------------	---------------------------

#### 3.2 Overall Test Conditions

Work Area	Relative Humidity (%)	Air Pressure (mbar)	Ambient Temperature (°C)
Site 1-5	62	1005	18.9
Sites 6-10	63	1015	21.1

July 2013

Work Area	Relative Humidity (%)	Air Pressure (mbar)	Ambient Temperature (°C)
Site 1	28-38	995-1005	19-21

#### 3.3 Test Methods

The objective of the report is to perform testing according to 47 CFR Part 15 Subpart C (Bluetooth and WIFI, 2.4GHz ISM band radiators) for the EUT FCC ID Certification and RSS-210 for the Industry Canada certification:

Number	Standard Number	Document Title
1	47 CFR Part 15 (10-01-09 Edition)	Radio Frequency Devices
2	RSS-210 Issue 8 December 2010	Licence-exempt Radio Apparatus (All Frequency Bands): Category I Equipment

##### 3.3.1 Deviations from Test Methods

None

## 4 EUT Information

### 4.1 Test Rationale

Full compliance
-----------------

Additional units covered by this report

FCC ID	PJ5-WFBT5
IC ID	4069B-WFBT5
Unique Type Identification:	E70163 / a67 WiFi
	E70162 / a65 WiFi
	E70201 / a68 WiFi

### 4.2 Description of Equipment under Test (EUT)

Date of Receipt:	26-11-2012
Client:	Raymarine UK Ltd
Brand Name:	a67 WiFi
Product Range:	Multifunction Display with Sonar
Country of Manufacture:	China
Operational voltage range:	10.8V to 15.6V

#### Unit 1

Model Name or Number:	a67 WiFi
FCC ID	PJ5-WFBT5
IC ID	4069B-WFBT5
Unique Type Identification:	EMC121126B
Serial Number:	E701631120001
CCT Diagram Number(s) & Issue:	<p><b><u>Chartplotter + BT Variant E70162</u></b></p> <p>CPU 1002291 Issue 7 GPS 1001651 Issue 3 Keyboard 1001671 Issue 1 Chart Reader 1001661 Issue 1</p> <p><b><u>Chartplotter + Sonar + BT Variant E70163</u></b></p> <p>CPU 1002293 Issue 7 Sonar 1001521 Issue 3 GPS 1001651 Issue 3 Keyboard 1001671 Issue 1 Chart Reader 1001661 Issue 1</p>

PCB Assembly Number(s) & Issue:	<p><b><u>Chartplotter + WiFi + BT Variant E70162</u></b>                  CPU 1002292 Issue 6                  GPS 1001654 Issue 3                  Keyboard 1001674 Issue 1                  Chart Reader 1001664 Issue 1  <b><u>Chartplotter + Sonar + WiFi + BT Variant E70163</u></b>                  CPU 1002294 Issue 6                  Sonar 1001524 Issue 3                  GPS 1001654 Issue 3                  Keyboard 1001674 Issue 1                  Chart Reader 1001664 Issue 1</p>
Software Version:	Platform Application
Modifications to Unit:	

**Unit 2**

Model Name or Number:	A68
Unique Type Identification:	E70200
Serial Number:	EMC130122a
CCT Diagram Number(s) & Issue:	CPU 1002515-10 (a68) CPU 1002293-10 (a68 WIFI) Sonar 1002570-2 Keyboard 1001673-1 GPS 1001653-5 Chart 1001663-1
PCB Assembly Number(s) & Issue:	CPU 1002516-10 (a68) CPU 1002294-10 (a68 WIFI) Sonar 1002574-2 Modified under deviation D-13-0184 v3 Keyboard 1001674-1 GPS 1001654-5 Chart 1001664-1
Software Version:	Boot 7.26-00132 Kernel 3.4.41-rm Application 7.31-00616
Modifications to Unit:	

4.3 Additional information

This test report is also applicable to E70162 a65 WiFi Multifunction Display. The only difference between the a65 WiFi & a67 WiFi is the a65 does not have a built in sonar. All other functionality & features are the same.

Addition of a68 display.

Experience in testing these displays has shown that the emissions from the all displays below 2GHz are due to the electronics associated with the display and not the RF chip set. Testing a a68 Bluetooth version will give identical results to a a68 WiFi version below 2GHz. All emissions above 2GHz are associated with the RF module which is identical on a65, a67 and a68 displays

#### 4.4 Description of Auxiliary Equipment

Product Type	Part Number	Serial Number
none		



## 4.5 Test Configurations

### 4.5.1 Maximum Power, EIRP Spectral Density and Frequency Range tests

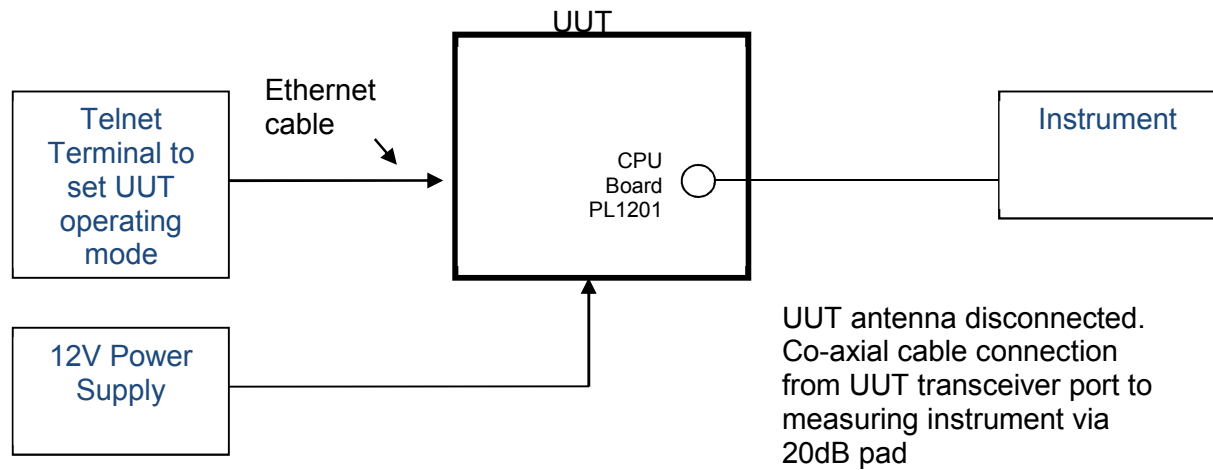

### 4.5.2 Photos

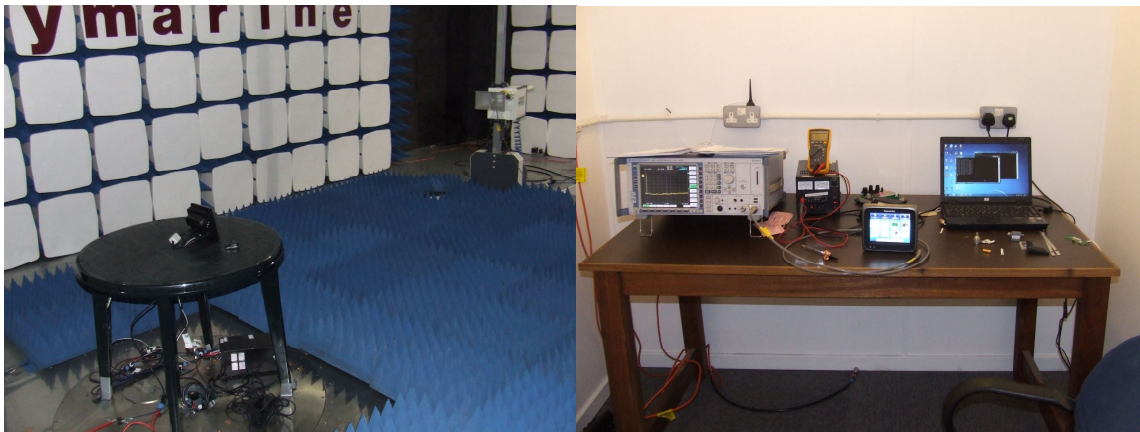

## 4.6 Operating Modes

### 4.6.1 Peak Output Power and Frequency Range

The tests performed with the UUT in each of three operating modes:

- Continuously transmitting 802.11b 11Mbps DSSS CCK @ 20dBm nominal
- Continuously transmitting 802.11g 54Mbps OFDM @ 14.5dBm nominal
- Continuously transmitting 1Mbps Bluetooth GFSK, fixed frequency @ 9.5dBm nominal

## 5 Test Results

### 5.1 Transmit Duty Cycle, “x”

Transmit duty cycle (symbol “x”) is required for the calculations relating average power (measured) to EIRP for Maximum Transmit Power, Maximum EIRP Spectral Density and Frequency Range tests.

UUT Operating Mode	Period (ms)	Transmit On (ms)	Transmit Duty Cycle, x
11Mbps 802.11b DSSS CCK 20dBm nominal	3.0000	1.0000	0.3333
54Mbps 802.11g OFDM 14.5dBm nominal	2.2000	0.2200	0.1000
1Mbps Bluetooth GFSK 9.5dBm nominal	1.0000	1.0000	1.0000

### 5.2 UUT Antenna Gain, “G”

Antenna gain (symbol “G”) is required for the calculations relating average power (measured) to EIRP for Maximum Transmit Power, Maximum EIRP Spectral Density and Frequency Range tests.

UUT Max Antenna Gain (dBi)
+0.8

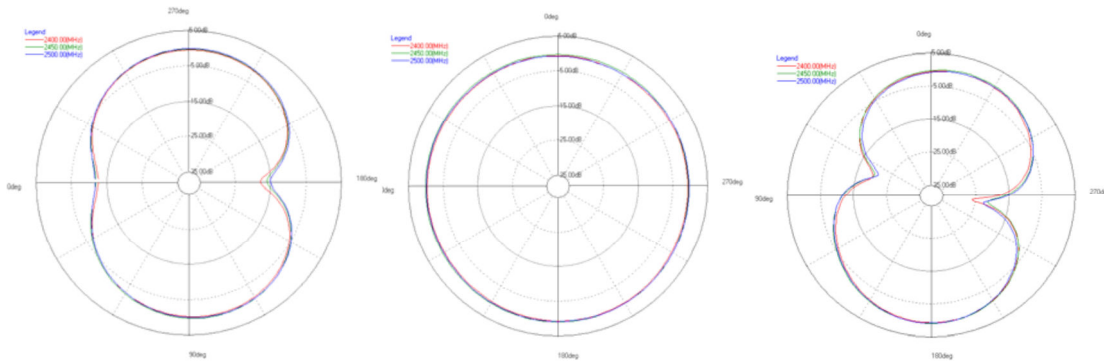

## 5.3 Peak Output Power

Conducted measurements as specified in 15.247(b)(1).

## 5.3.1 Normal Test Conditions; 22°C, 12.0V

Operating Mode (Modulation)	Channel \ Frequency (No. \ MHz)	Power Reading (dBm)	Attenuator Correction (dB)	Power Measured A (dBm)	Tx Duty Cycle x	Peak Power (mW)	Limit max. (mW)	Pass/Fail
11Mbps 802.11b DSSS 20dBm nominal	1 \ 2412	-9.5	21.85	12.35	0.3333	51.54	125	Pass
	7 \ 2442	-9.7	21.85	12.15	0.3333	49.22	125	Pass
	13 \ 2472	-9.7	21.85	12.15	0.3333	49.22	125	Pass
54Mbps 802.11g OFDM 14.5dBm nominal	1 \ 2412	-21.2	21.85	0.65	0.1000	44.67	125	Pass
	7 \ 2442	-21.3	21.85	0.55	0.1000	35.48	125	Pass
	13 \ 2472	-21.3	21.85	0.55	0.1000	35.48	125	Pass
1Mbps Bluetooth GFSK 9.5dBm nominal	1 \ 2402	-13.8	21.85	8.05	1.0000	6.38	125	Pass
	48 \ 2480	-13.5	21.85	8.35	1.0000	6.84	125	Pass
	79 \ 2479	-13.1	21.85	8.75	1.0000	7.5	125	Pass

### 5.4 Frequency Hopping Requirements

UUT frequency hopping characteristics are as defined by the Bluetooth system specification

47 CFR 15.247(a)		Bluetooth	Pass / Fail
Technical Specification	Limit		
Dwell Time 15.247(a)	0.4s	0.38s Based on 79 Channels	Pass
Channel Separation 15.247(a)	Channels non-overlapping, 1MHz separation measured at 20dB below peak power	Complies with this requirement	Pass
Hopping Sequence 15.247(a)	Non-adaptive hopping uses 15 channels min.	79	Pass
	Adaptive hopping uses 90% min. of 2.4000 to 2.4835 band	N/A	
	Adaptive hopping uses 20 channels min.	N/A	
	Each channel occupied at least once during period $T = 4 \times \text{dwell time} \times \text{no. of channels}$	The Bluetooth channel hopping sequence is designed to visit each 1 MHz channel spacing frequency regularly and with roughly equal probability	

## 5.5 Frequency Range

Conducted measurements as specified in EN 300 328 V1.7.1 (2006-10) clause 5.7.4.1 were used.

Operating Mode (Modulation)	Spectral Power Density Threshold relative to EIRP (dBm, RBW = 100kHz)	fL Ch1 \ 2.412GHz (GHz)	fL limit min. (GHz)	Pass if fL > fL limit?	fH Ch13 \ 2.472GHz (GHz)	fH limit max. (GHz)	Pass if fH < fH limit?	fH - fL (GHz)
11Mbps 802.11b DSSS 20dBm nominal	-30.0000	<b>2.4034</b>	2.4000	Pass	<b>2.4805</b>	2.4835	Pass	0.0771
54Mbps 802.11g OFDM 14.5dBm nominal	-30.0000	<b>2.4037</b>	2.4000	Pass	<b>2.4803</b>	2.4835	Pass	0.0766
1Mbps Bluetooth GFSK 9.5dBm nominal	-30.0000	<b>2.4013</b>	2.4000	Pass	<b>2.4807</b>	2.4835	Pass	0.0794

## 5.6 Medium Access Protocol

		UUT
Technical Specification	Requirement	
Medium Access Protocol	A medium access protocol shall be implemented by the equipment	The UUT implements medium access protocols defined by Bluetooth and IEEE 802.11 b/g specifications

5.7 20dB Channel Bandwidth

Modulation 11Mbps 802.11b DSSS 20dBm nominal	-20dB frequencies		-20dB BW
	fL (GHz)	fH (GHz)	fH - fL (MHz)
Ch1 \ 2.412GHz	2.40337	2.42067	17.308
Ch7 \ 2.442GHz	2.4333	2.4508	17.468
Ch11 \ 2.462GHz	2.45337	2.4707	17.308

Modulation 54Mbps 802.11g OFDM 14.5dBm nominal	-20dBC frequencies		-20dB BW
	fL (GHz)	fH (GHz)	fH - fL (MHz)
Ch1 \ 2.412GHz	2.4016	2.4228	21.15
<p>Center: 2.41201795 GHz 10 MHz/ Span 100 MHz</p> <p>Date: 28_JAN_2013 16:11:17</p>			
Ch7 \ 2.442GHz	2.4317	2.4526	20.83
<p>Center: 2.44200011 GHz 10 MHz/ Span 100 MHz</p> <p>Date: 28_JAN_2013 16:13:00</p>			
Ch11 \ 2.462GHz	2.4519	2.4726	20.67
<p>Center: 2.458814103 GHz 10 MHz/ Span 100 MHz</p> <p>Date: 28_JAN_2013 16:13:43</p>			



Modulation 1Mbps Bluetooth GFSK 9.5dBm nominal	-20dBC frequencies		-20dB BW
	fL (GHz)	fH (GHz)	fH - fL (MHz)
Ch1 \ 2.402GHz	2.40143	2.40256	1.1378
<p>Date: 28.JAN.2013 17:39:16</p>			
Ch40 \ 2.441GHz	2.44043	2.44157	1.138
<p>Date: 28.JAN.2013 17:38:25</p>			
Ch79 \ 2.480GHz	2.47942	2.48056	1.1378
<p>Date: 28.JAN.2013 17:37:33</p>			

5.8 Frequency Band Edges

Modulation	-20dBc frequencies	
	fL (GHz)	fH (GHz)
11Mbps 802.11b DSSS 20dBm nominal		
Lower Band Edge Ch1 \ 2.412GHz	2.40337	
Upper Band Edge Ch11 \ 2.462GHz		2.4707
54Mbps 802.11g OFDM 14.5dBm nominal		
Lower Band Edge Ch1 \ 2.412GHz	2.4016	
Upper Band Edge Ch11 \ 2.462GHz		2.4726
1Mbps Bluetooth GFSK 9.5dBm nominal		
Lower Band Edge Ch1 \ 2.402GHz	2.40143	
Upper Band Edge Ch79 \ 2.480GHz		2.48056

5.9 6dB Channel Bandwidth (RSS-210)

Modulation	-6dB BW (MHz)	Limit	
11Mbps 802.11b DSSS 20dBm nominal		>500kHz	
Ch1	10.74		Pass
Ch7	10.897		Pass
Ch11	10.577		Pass
54Mbps 802.11g OFDM 14.5dBm nominal			
Ch1	16.506		Pass
Ch7	16.506		Pass
Ch13	16.346		Pass

5.10 Power Spectral Density (RSS-210)

Modulation	PSD dBm	Limit dBm	
11Mbps 802.11b DSSS 20dBm nominal		<8dBm	
Ch1	-7.5		Pass
Ch7	-7.61		Pass
Ch11	-7.23		Pass
54Mbps 802.11g OFDM 14.5dBm nominal			
Ch1	-15.75		Pass
Ch7	-15.80		Pass
Ch11	-15.78		Pass

## 5.11 Transmitter Spurious Emissions

### 5.11.1 Radiated Emissions 9kHz-150kHz

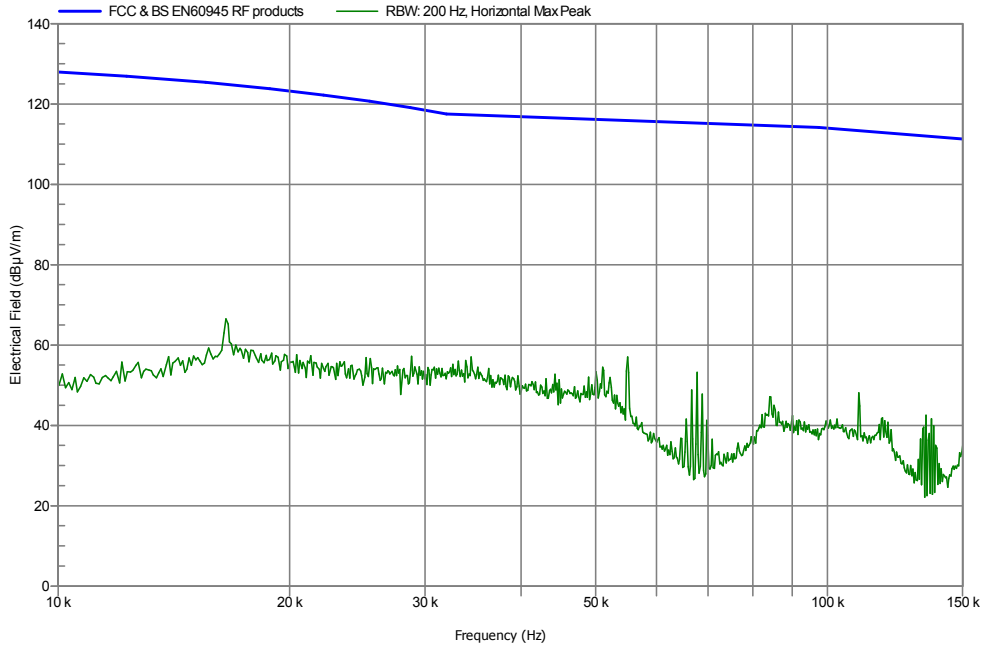

Loop Face On

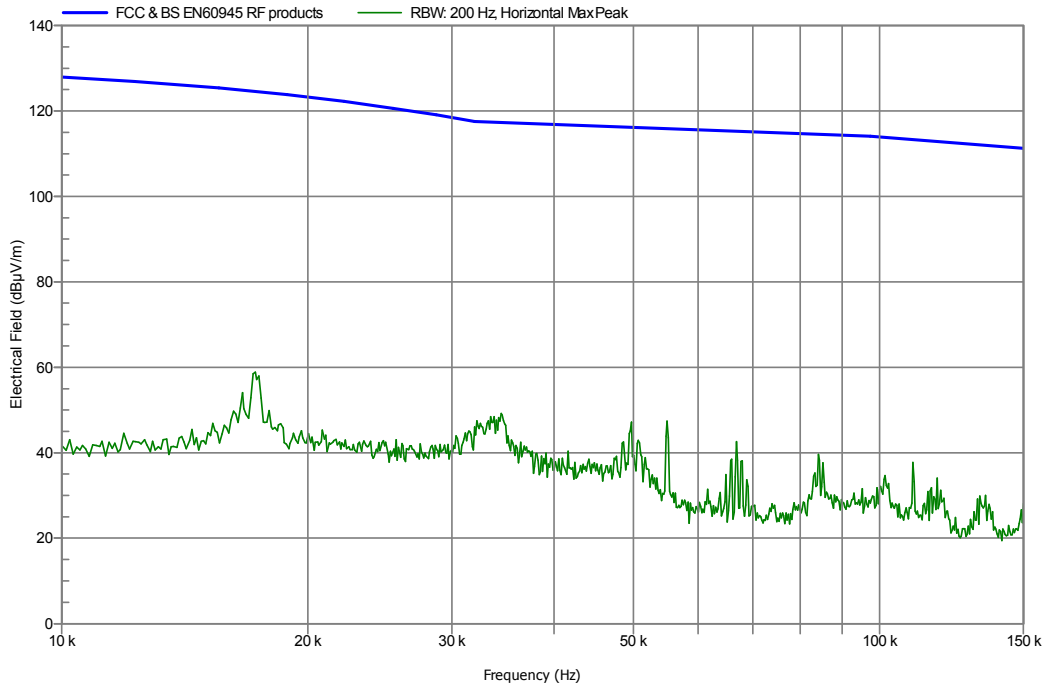

Loop Side On

5.11.2 Radiated Emissions 150kHz-30MHz

a67 WiFi

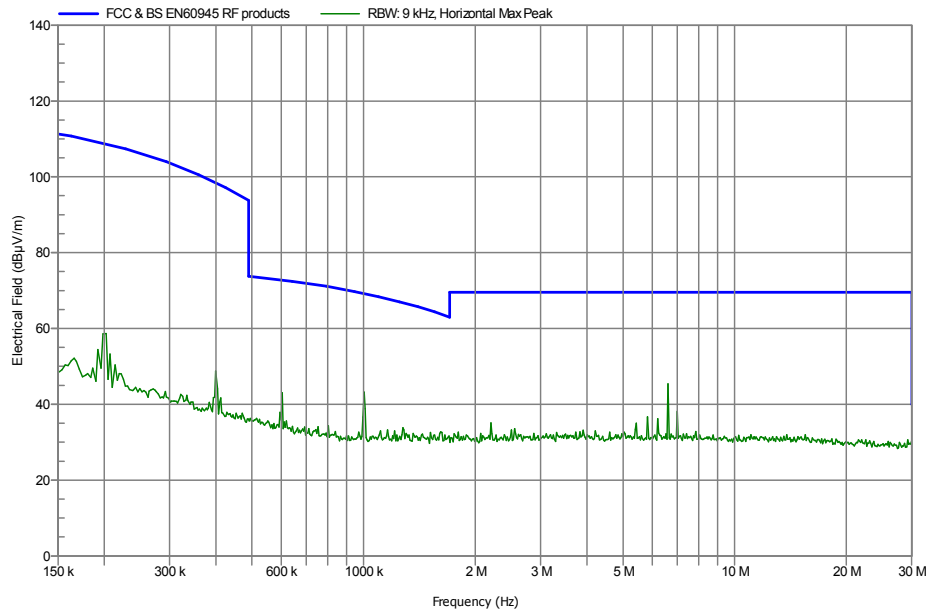

Loop Face On

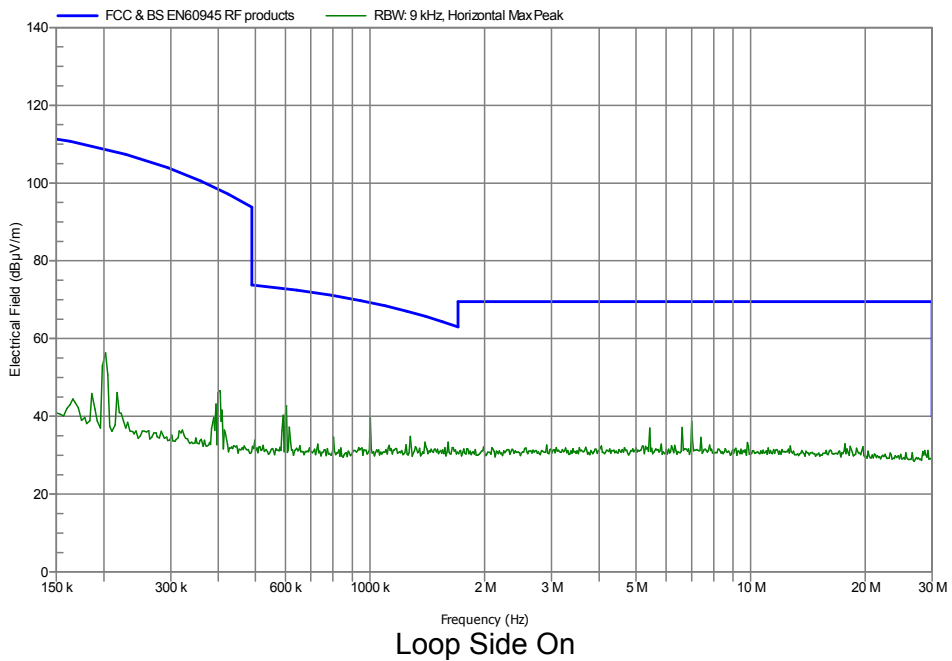

Loop Side On

a68

X polarity (Face on)  
30ft range

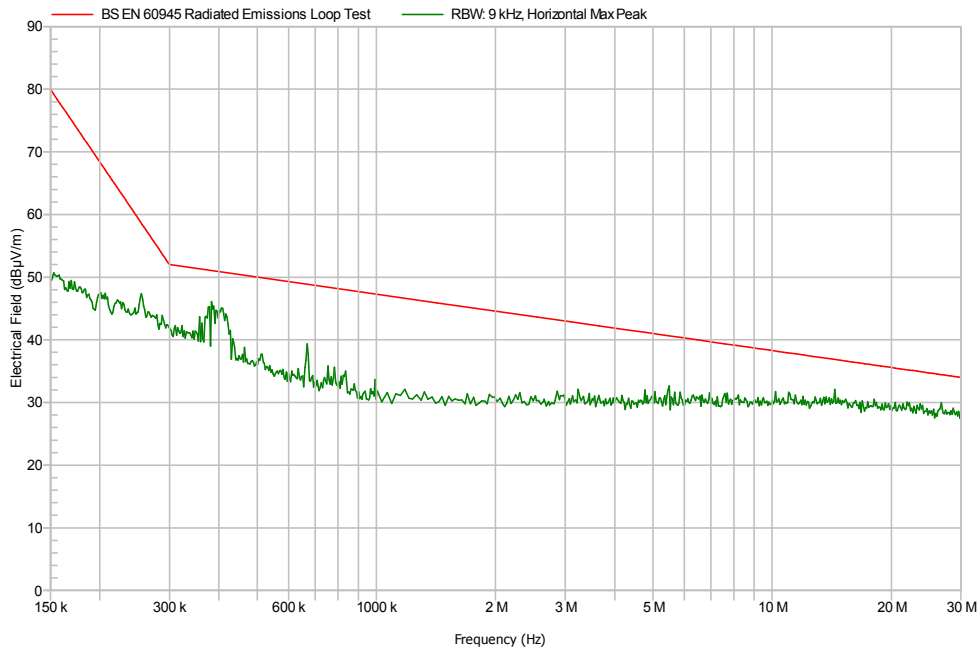

400ft range

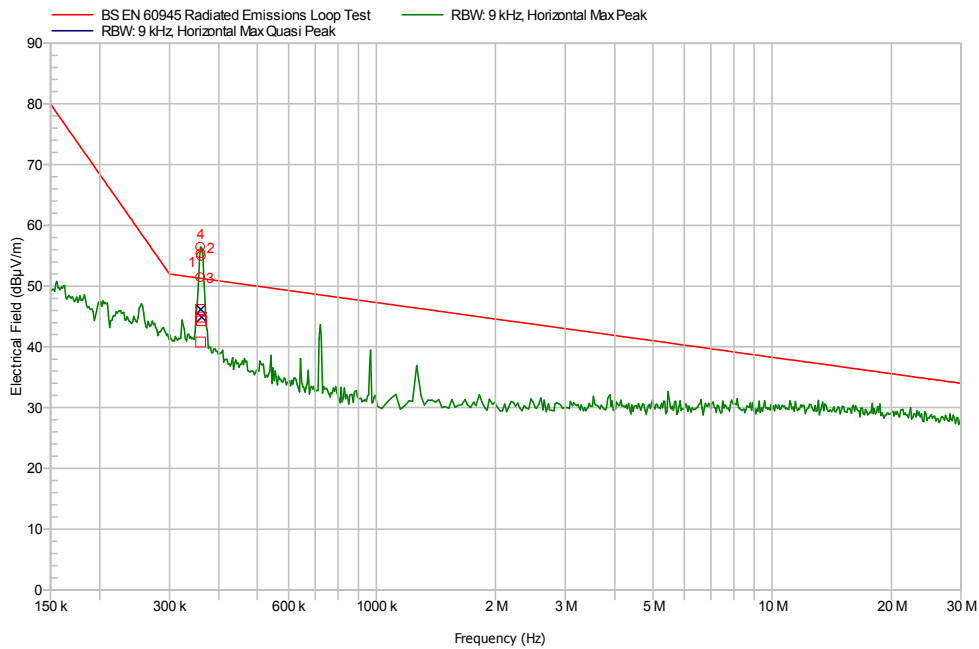

Y polarity (Side on)  
30ft range

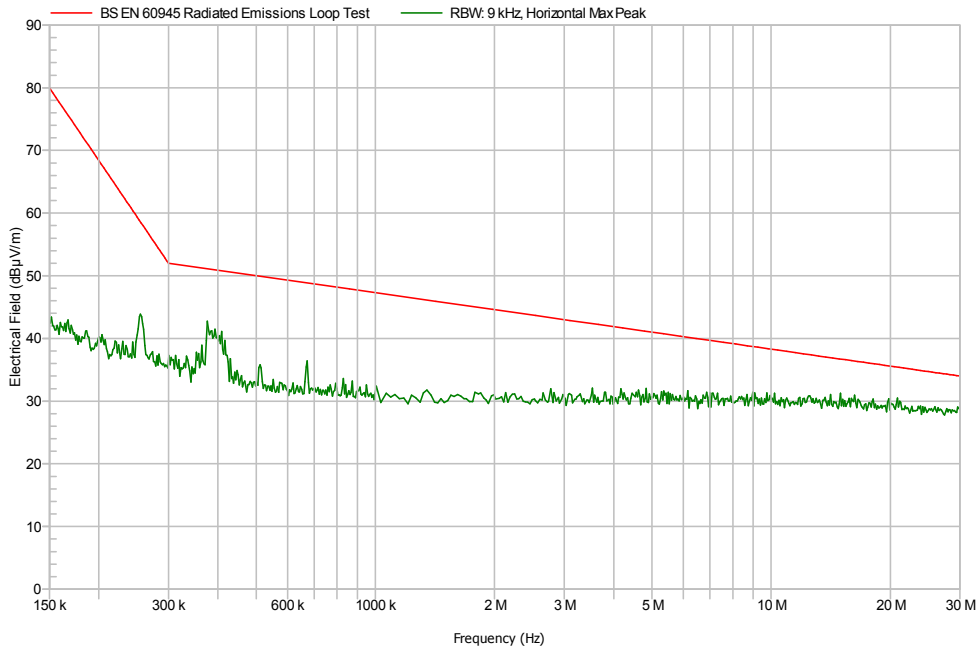

400ft range

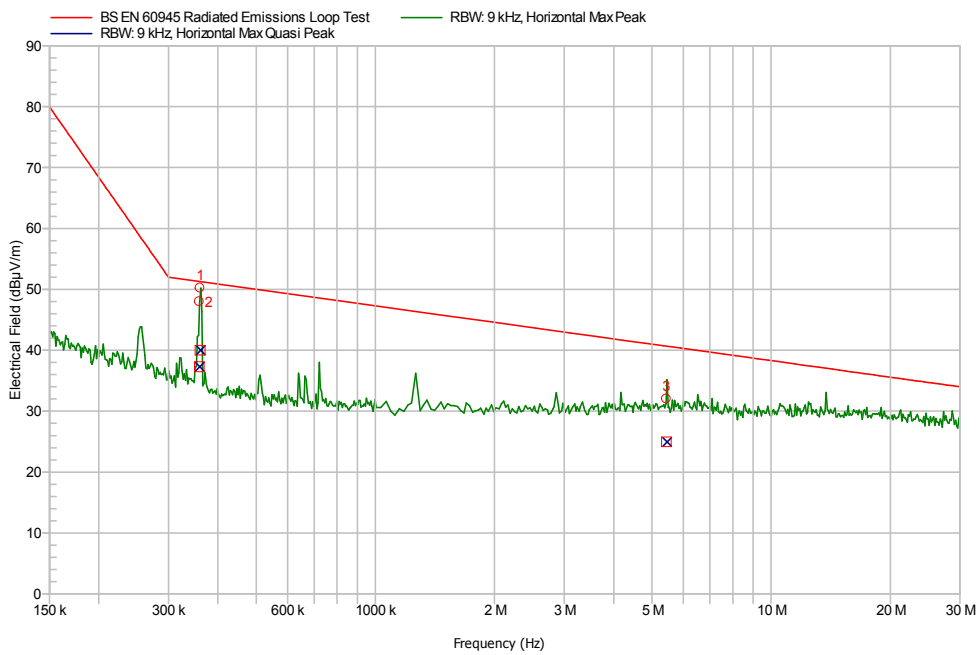

5.11.3 Radiated Emissions 30MHz – 300MHz

A67 WiFi

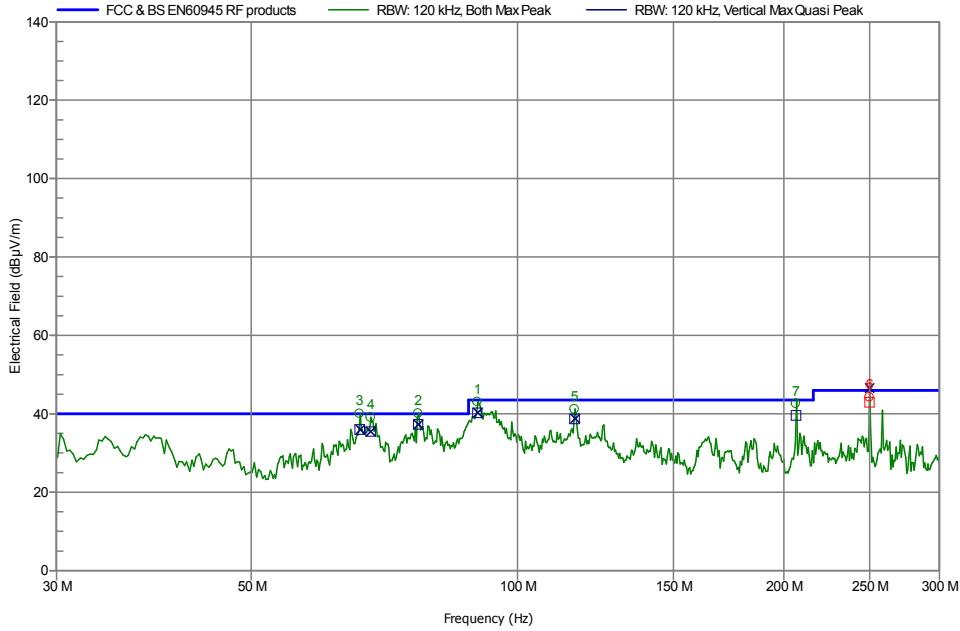

Peak identifier	Frequency	Peak	Quasi-Peak	Quasi-Peak Limit	Quasi-Peak Difference	Quasi-Peak Status	Angle	Height	Polarization
1	90.074 MHz	43.06 dBµV/m	40.28 dBµV/m	43.5 dBµV/m	-3.22 dB	Pass	15 Degree	1.2 m	Vertical
2	77.203 MHz	40.08 dBµV/m	37.29 dBµV/m	40 dBµV/m	-2.71 dB	Pass	60 Degree	1.1 m	Vertical
3	66.296 MHz	40.06 dBµV/m	36 dBµV/m	40 dBµV/m	-4 dB	Pass	67 Degree	1.04 m	Vertical
4	68.231 MHz	39.1 dBµV/m	35.48 dBµV/m	40 dBµV/m	-4.52 dB	Pass	75 Degree	1.04 m	Vertical
5	116.01 MHz	41.14 dBµV/m	38.69 dBµV/m	43.5 dBµV/m	-4.81 dB	Pass	180 Degree	1.04 m	Vertical
6	250.005 MHz	44.24 dBµV/m	42.92 dBµV/m	46 dBµV/m	-3.08 dB	Pass	315 Degree	100 cm	Vertical
7	206.445 MHz	42.63 dBµV/m	39.59 dBµV/m	43.5 dBµV/m	-3.91 dB	Pass	232 Degree	1.79 m	Horizontal

a68

a68 display

30ft Range



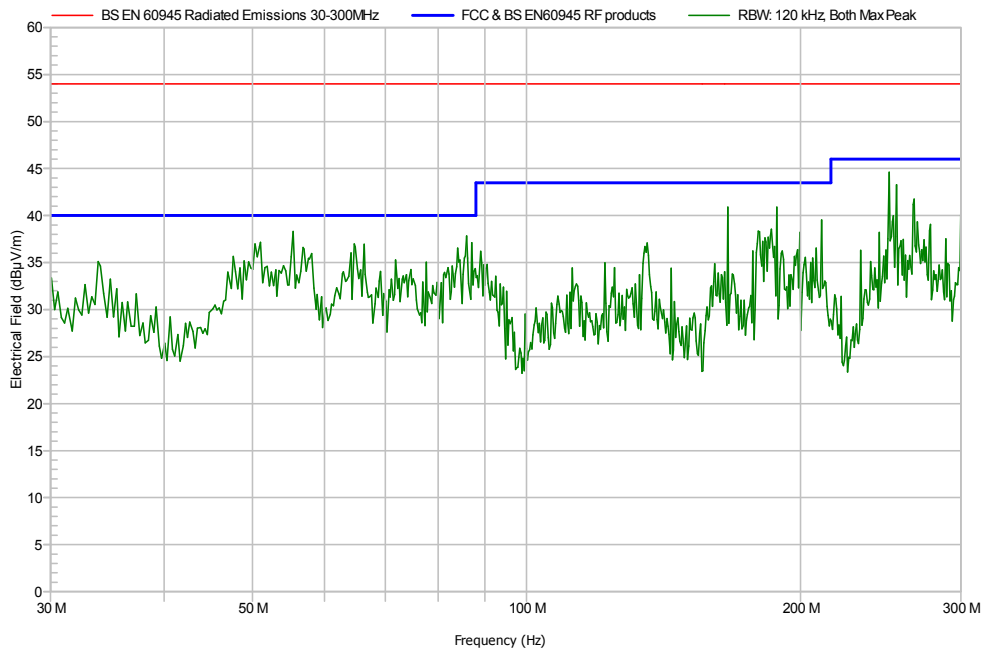

400ft Range

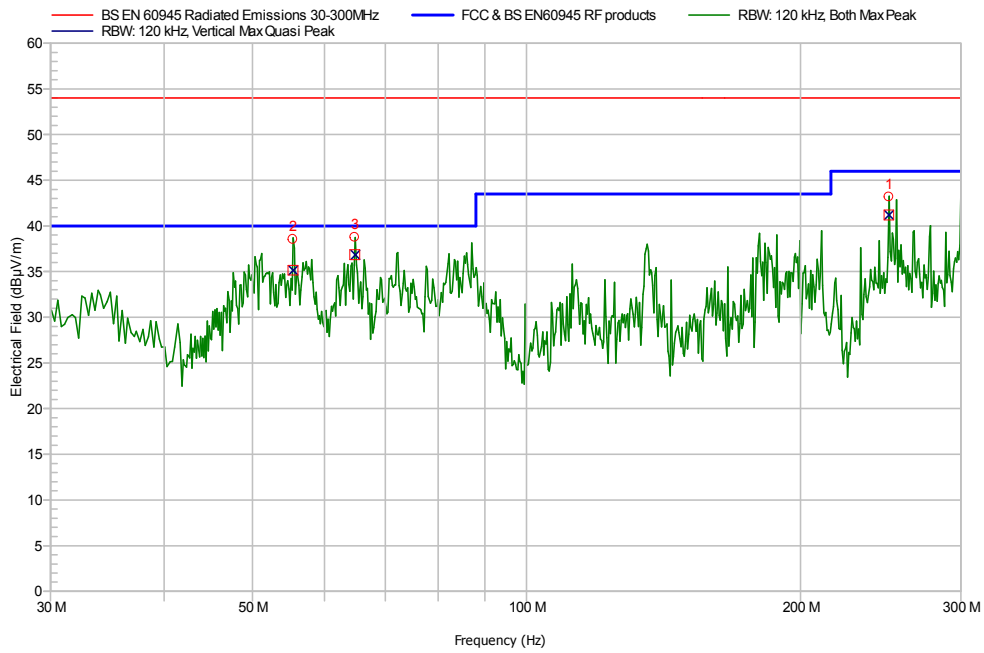

Nr	Frequency	Peak	Quasi-Peak	Quasi-Peak Difference	Status
1	250.006 MHz	43.18 dBµV/m	41.2 dBµV/m	-4.8 dB	Pass
2	55.405 MHz	38.53 dBµV/m	35.16 dBµV/m	-4.84 dB	Pass
3	64.778 MHz	38.75 dBµV/m	36.86 dBµV/m	-3.14 dB	Pass

5.11.4 Radiated Emissions 300MHz-1GHz

a67

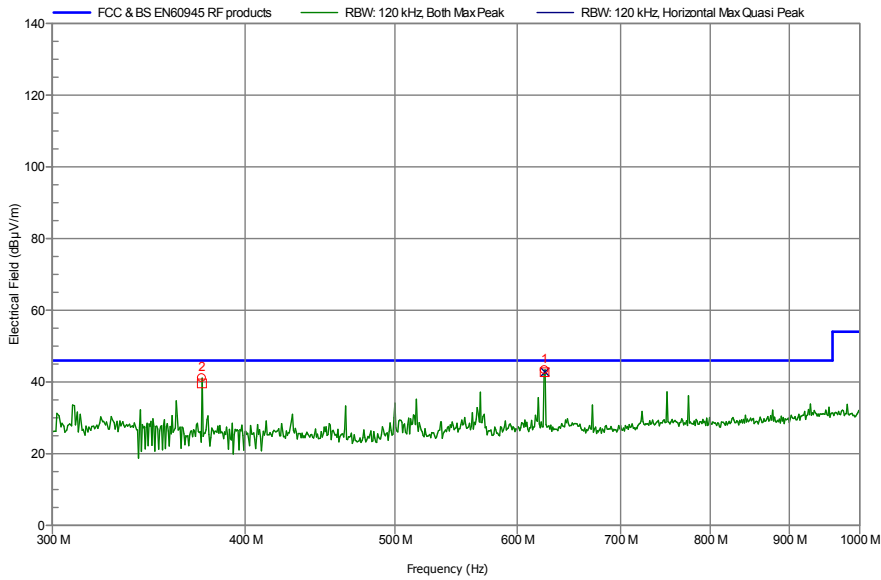

Peak identifier	Frequency	Peak	Quasi-Peak	Quasi-Peak Limit	Quasi-Peak Difference	Quasi-Peak Status	Angle	Height	Polarization
1	625.002 MHz	43.32 dBµV/m	42.75 dBµV/m	46 dBµV/m	-3.25 dB	Pass	150 Degree	1.79 m	Horizontal
2	374.996 MHz	41.08 dBµV/m	39.56 dBµV/m	46 dBµV/m	-6.44 dB	Pass	0 Degree	1.04 m	Vertical

a68

30ft Range

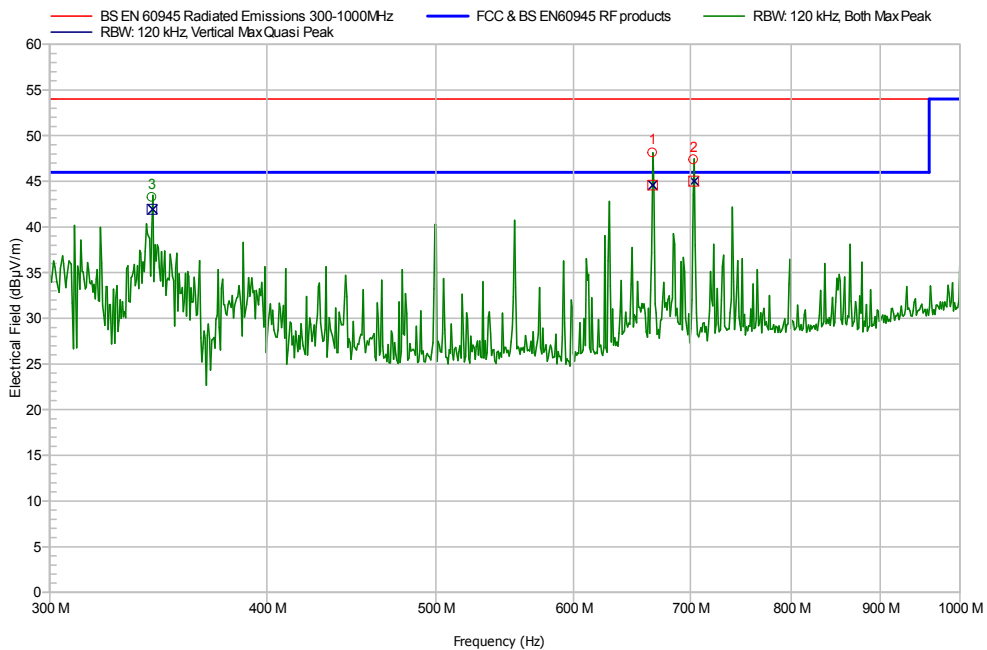

Nr	Frequency	Peak	Quasi-Peak	Quasi-Peak Difference	Status
1	666.025 MHz	48.12 dBµV/m	44.58 dBµV/m	-1.42 dB	Pass
2	703.064 MHz	47.36 dBµV/m	45.02 dBµV/m	-0.98 dB	Pass
3	343.59 MHz	43.24 dBµV/m	41.93 dBµV/m	-4.07 dB	Pass

400ft Range

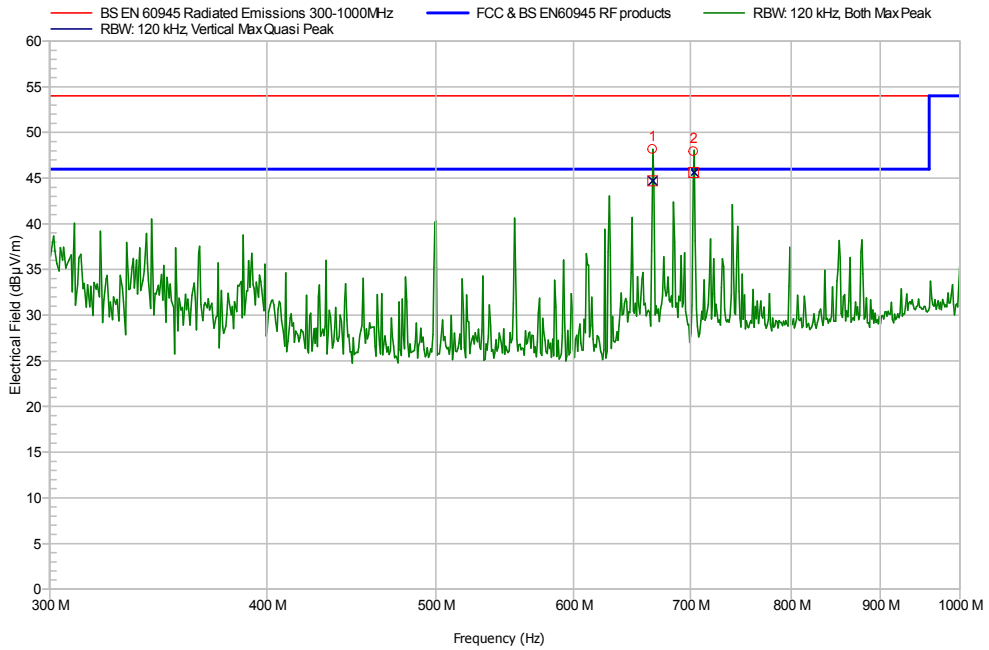

Nr	Frequency	Peak	Quasi-Peak	Quasi-Peak Difference	Status
1	665.998 MHz	48.14 dBµV/m	44.71 dBµV/m	-1.29 dB	Pass
2	703.033 MHz	47.9 dBµV/m	45.61 dBµV/m	-0.39 dB	Pass

5.11.5 Radiated Emissions 1GHz-2GHz

a67

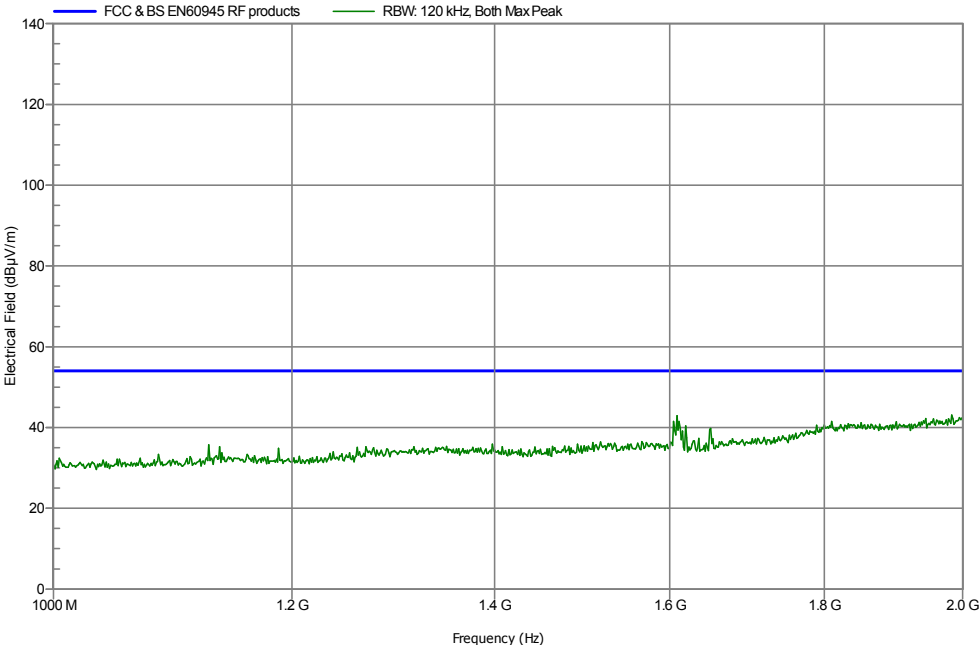

a68

### 30ft Range

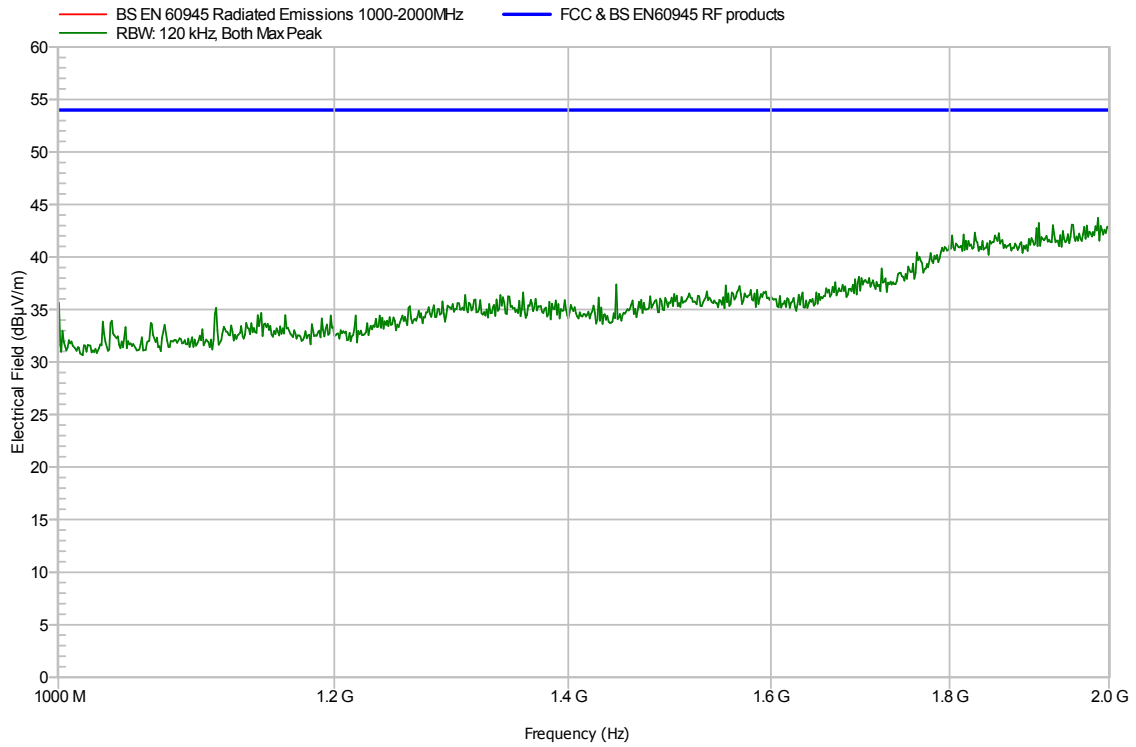

### 400ft Range

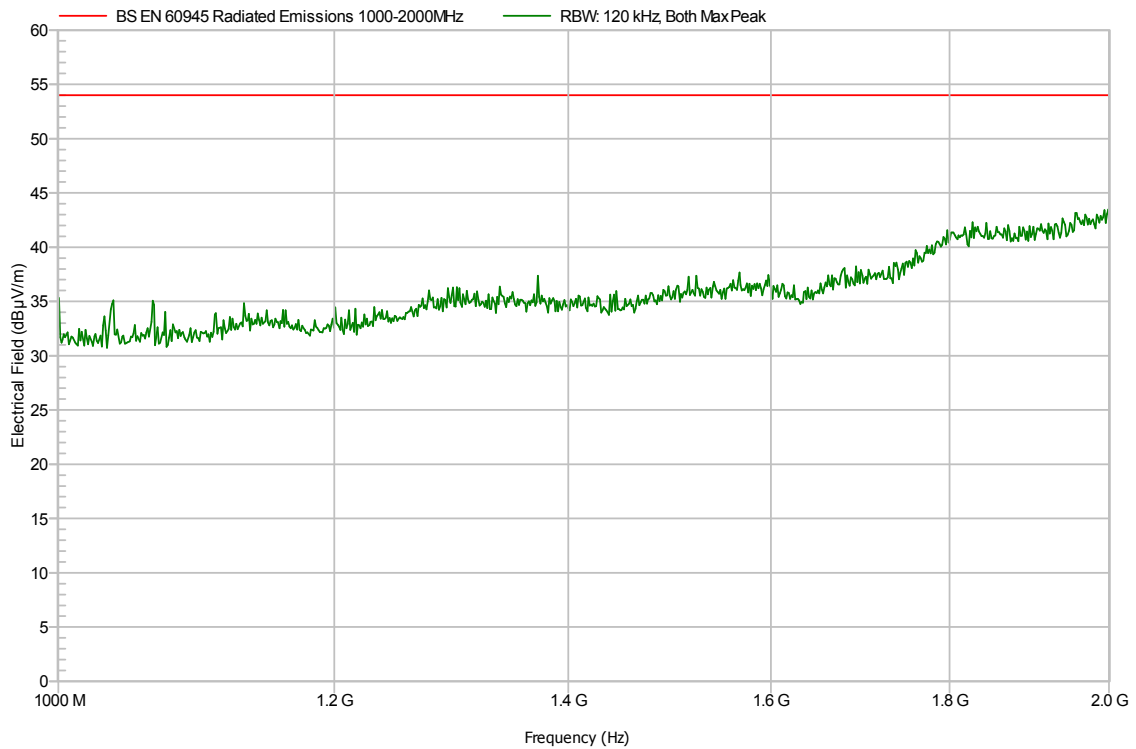

5.11.6 Radiated Emissions 2GHz-18GHz (2.4GHz block used on ESU40)

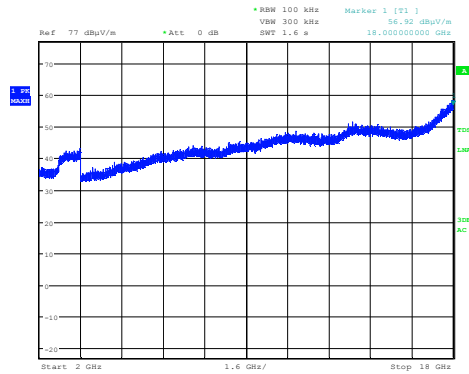

Date: 26.NOV.2012 11:39:59

802.11b Channel 1 (2402MHz)

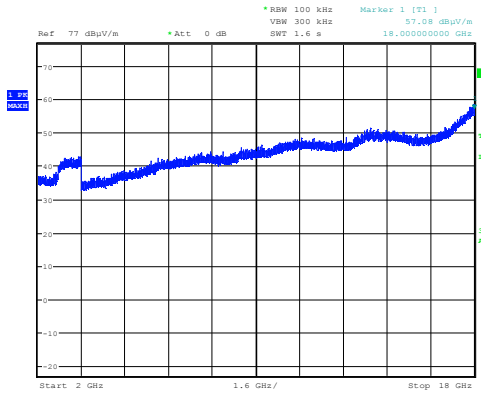

Date: 26.NOV.2012 11:44:14

802.11b Channel 7 (2442MHz)

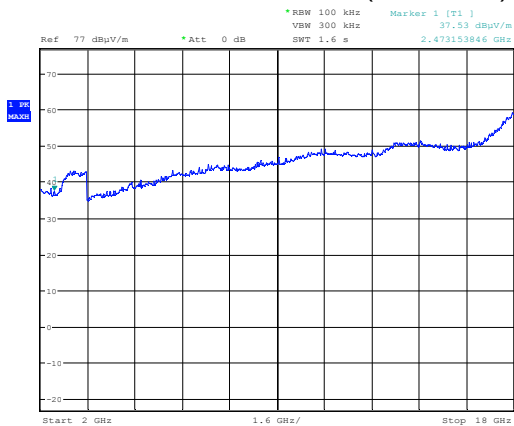

Date: 23.NOV.2012 14:18:57

802.11b Channel 13 (2480MHz)

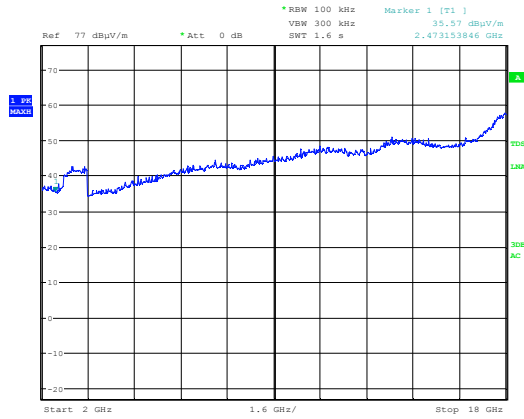

Date: 23.NOV.2012 14:21:05

### 802.11g Ch1 (2412MHz)

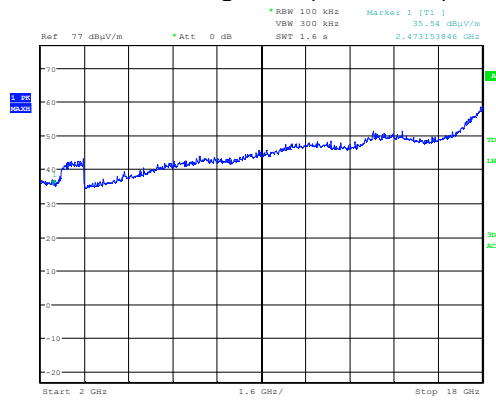

Date: 23.NOV.2012 14:23:17

### 802.11g Ch7 (2442MHz)

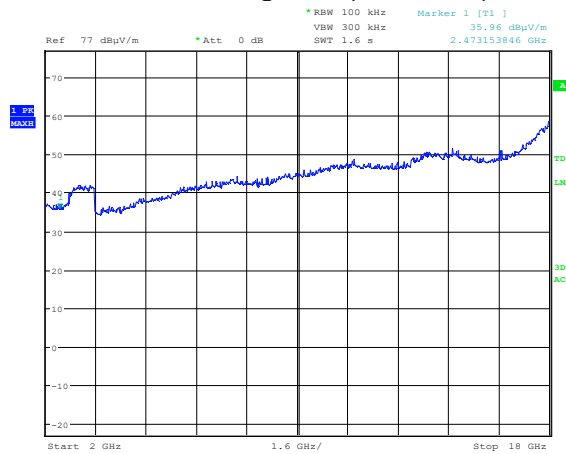

Date: 23.NOV.2012 14:25:40

### 802.11g Ch13 (2472MHz)

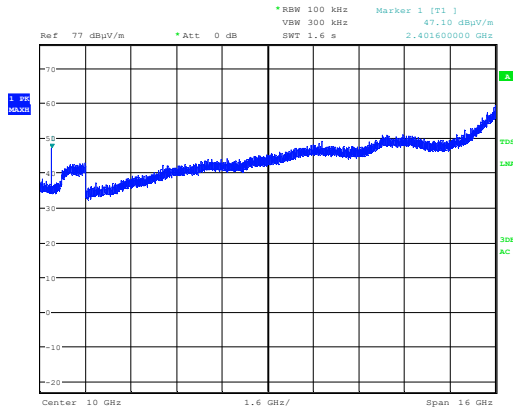

Date: 23.NOV.2012 16:46:27

### BT Ch1(2402MHz)

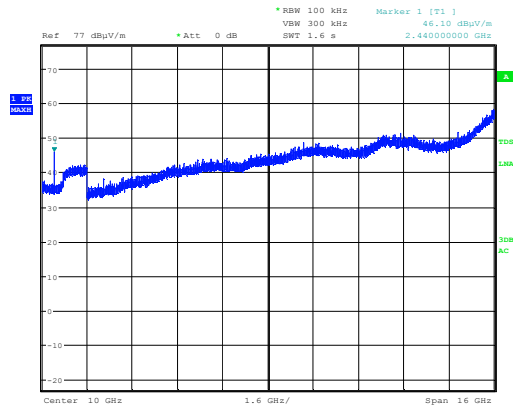

Date: 23.NOV.2012 16:49:12

### BT Ch40 (2441MHz)

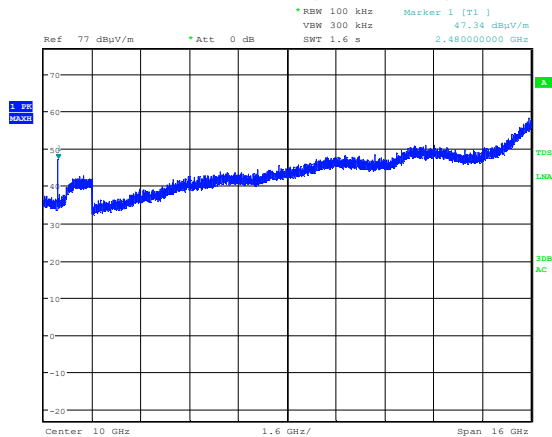

Date: 23.NOV.2012 16:52:26

### BT Ch79 (2479MHz)



5.11.7 Radiated Emissions 18GHz-26GHz

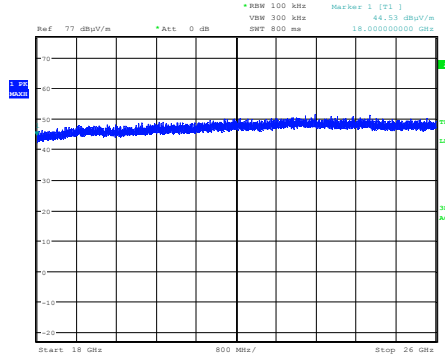

Date: 23.NOV.2012 17:10:28

802.11b Channel 1 (2402MHz)

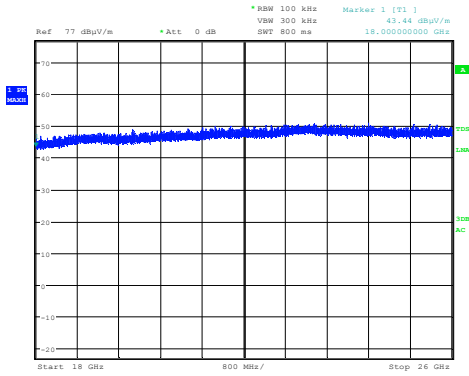

Date: 23.NOV.2012 17:13:37

802.11b Channel 7 (2442MHz)

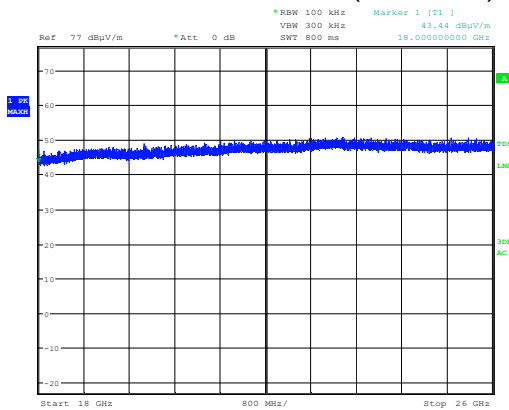

Date: 23.NOV.2012 17:13:37

802.11b Channel 13 (2480MHz)

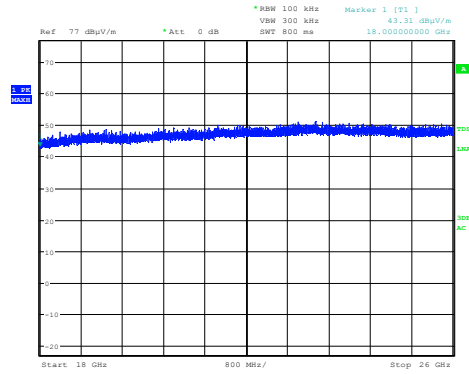

Date: 23.NOV.2012 17:20:52

### 802.11g Ch1 (2412MHz)

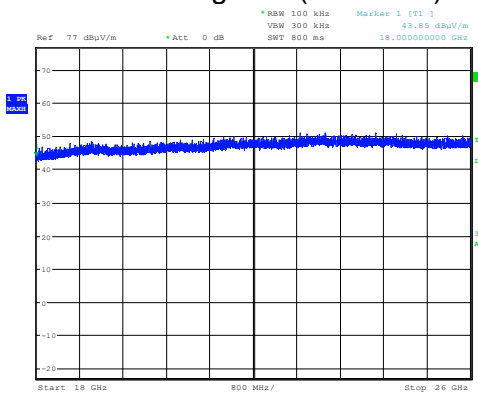

Date: 23.NOV.2012 17:23:18

### 802.11g Ch7 (2442MHz)

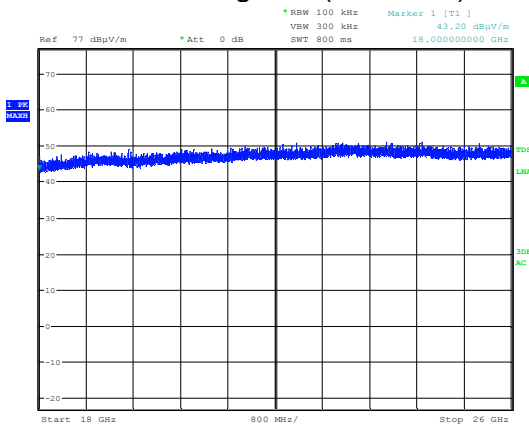

Date: 23.NOV.2012 17:25:51

### 802.11g Ch13 (2472MHz)



### 5.12 Receiver Spurious Emissions

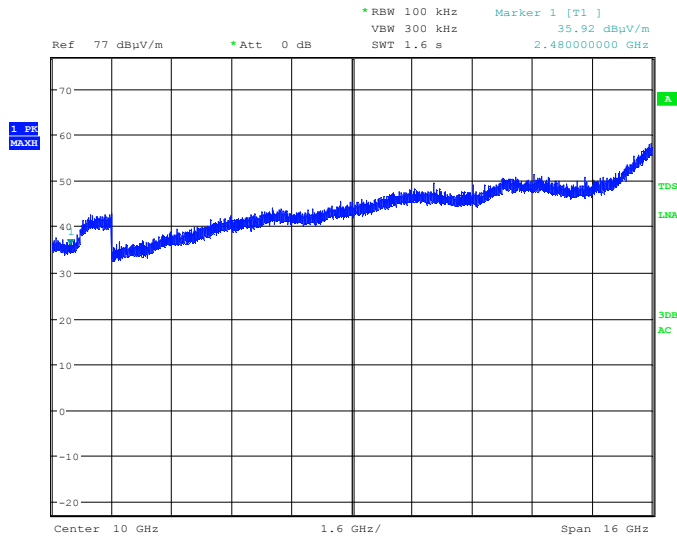

Date: 23.NOV.2012 16:57:51

#### Receiver spurious emissions 2GHz-18GHz

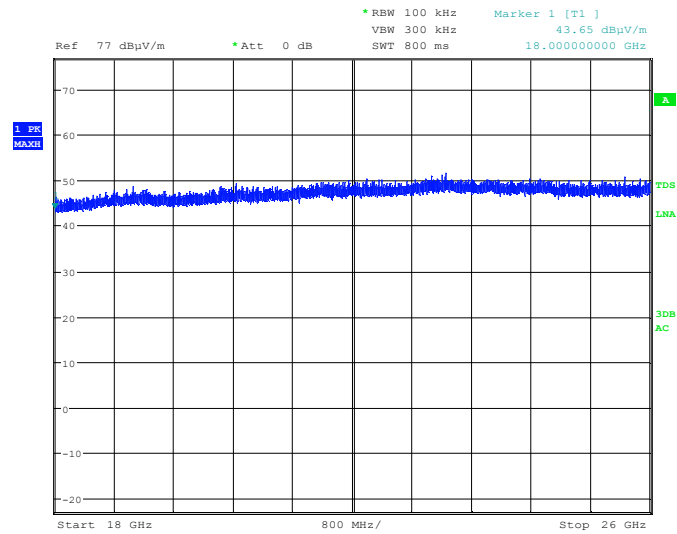

Date: 23.NOV.2012 17:07:07

#### Receiver Spurious Emissions 18GHz-26GHz

## 6 List of Test Equipment

Test Equipment Type	Manufacturer and Type Number	Serial Number	Cal No.	Cal Due
Digital Multimeter	Fluke 175	97460092	2248	11/11/2012
EMI Receiver 20Hz to 26.5GHz	Rohde & Schwarz ESCI	100416	001692	30/11/2012
Active Loop Antenna 9kHz - 30MHz	Chase EMC HLA6120	1122	00442	14/2/2014
Loop Antenna PSU/Charger	Chase EMC CBP9721	N/A	02671	N/A
Antenna Horn 1-18GHz	Chase BBHA9120D	9120D-578	01719	2/11/2014
Antenna Horn 18GHz-26GHz	Credowan 20-R-2843-0007	36755	482	16/11/2014
Antenna 30MHz-3GHz	Chase CBL6141	22932	01802	23/07/2014
Antenna Mast (Site 1)	Inn-co GmbH MM4000	MM4000/056/13750806/L	02075	N/A
Turntable (Site 1)	Inn-co GmbH DS1200S	DS1200S/175/13750806/L	02076	N/A
Mast/Turntable Controller (Site 1)	Inn-co GmbH Co 2000	CO/2000/359/137/50806/L	02077	N/A
EMI Receiver 20Hz to 40GHz	Rohde & Schwarz ESU40	100017	01721	20/02/2013
Power Supply Unit	Palstar PS30M	G290775401	2020	N/A

### a68 tests July 2013

Test Equipment Type	Manufacturer and Type Number	Serial Number	Cal No.	Cal Due
Semi-Anechoic Chamber, Site 1	Global EMC	GE001	02074	12/01/2015
Broadband Antenna 20-2000MHz	Chase EMC CBL6141	22932	01802	23/07/2014
Active Loop Antenna 9kHz - 30MHz	Chase EMC HLA6120	1122	00442	14/02/2014
Loop Antenna PSU/Charger	Chase EMC CBP9720	1076	00450	n/a
Antenna Mast (Site 1)	Inn-co GmbH MM4000	MM4000/056/13750806/L	02075	n/a
Turntable (Site 1))	Inn-co GmbH DS1200S	DS1200S/175/13750806/L	02076	n/a
Mast/Turntable Controller (Site 1)	Inn-co GmbH Co 2000	CO/2000/359/137/50806/L	02077	n/a
EMI Receiver 20Hz to 26.5GHz	Rohde & Schwarz ESI26	832692/006	00886	22/08/2013
Digital Multimeter	Fluke 175	97460092	02248	07/11/2013
Power Supply Unit	Palstar PS30M	520350606	01259	n/a
Computer (Site 1)			RM0401	n/a
Emissions Software	DARE RadiMation v5.3.18			n/a

In accordance with UKAS requirements, all measuring equipment is on a calibration cycle.