





Raymarine UK Ltd
 Marine House
 5 Harbourgate
 Southampton Road
 Portsmouth
 Hampshire
 PO6 4BQ
 Tel: 023 92714700

Email: compliance@raymarine.com

<http://www.raymarine.com>

Test Report for e7, e7D Marine Multifunction Displays

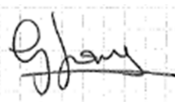
To 47 CFR Part 15 Subpart C and RSS 210

Model Number	E62354, E62355		
Product Description	e7, e7D Marine Multifunction Displays		
Report Number	TP/802/1066		
Report Author Graham Jones Senior Design Engineer		Date	18 th November 2011
Technical Check Michael Thompson EMC Engineer		Date	18 th November 2011
Approval Andrew Little Compliance Manager		Date	18 th November 2011

Test Date Range	09/08/2011 to 12/08/2011 and 17/11/2011
-----------------	---

Product Status	PASS
----------------	-------------

This test report shall not be reproduced except in full, without written approval of Raymarine UK Ltd.

The test data and results contained within this report relate only to the items tested.

1 47 CFR Part 15 and RSS-210 Test Summary

	CFR 47 Part 15	RSS-210	Section	Result
Hopping Sequence	15.247(a)		5.4	Pass
Peak Output Power	15.247(b)	A8.4(2)	5.3	Pass
Carrier Frequency Separation	15.247(a)	A8.1(b)	5.4	Pass
Frequency Band Edges	15.247(d)		5.8	Pass
20dB Bandwidth	15.247(a)(1)	A8.1(a)	5.7	Pass
Spurious Emissions	15.247(d)	A8.5	Separate Report	Pass
Number of Channels	15,247(a)(1)	A8.1(d)	5.4	Pass
Directional antenna with >6dBi	15.247(c)		Antenna<6dBi	N/A
Dwell Time	15.247(a)	A8.1(d)	5.4	Pass
6dB Bandwidth		A8.2(a)	5.10	Pass
Power Spectral Density		A8.2(b)	5.11	Pass

2 Attestations

This equipment has been tested in accordance with the standards identified in this report. To the best of *my/our* knowledge and belief, these tests were performed using the measurement procedures described in these reports.

All measuring instruments used to determine the status of the product's compliance to the identified standards are calibrated regularly in accordance with UKAS requirements.

A comprehensive system of traceable calibration in accordance with ISO9001 is maintained.

Name/Position	Signature	Date
Graham Jones Senior Electronics Engineer		11 th October 2011

I attest that the necessary measurements were made, under my supervision at:

Raymarine UK Ltd, Marine House, 5 Harbourgate, Southampton Road,
Portsmouth, PO6 4BQ.



Andy Little
Compliance Manager

Date: 12th October 2011

TABLE OF CONTENTS

1 47 CFR Part 15 and RSS-210 Test Summary 2

2 Attestations 3

3 Test Information 5

 3.1 Test Facilities 5

 3.2 Overall Test Conditions 5

 3.3 Test Methods 5

4 EUT Information 6

 4.1 Test Rationale 6

 4.2 Description of Equipment under Test (EUT) 6

 4.3 Additional information 7

 4.4 Description of Auxiliary Equipment 7

 4.5 Test Configurations 8

 4.6 Operating Modes 8

5 Test Results 9

 5.1 Transmit Duty Cycle, “x” 9

 5.2 UUT Antenna Gain, “G” 9

 5.3 Peak Output Power 11

 5.4 Frequency Hopping Requirements 12

 5.5 Frequency Range 13

 5.6 Medium Access Protocol 15

 5.7 20dB Channel Bandwidth 16

 5.8 Frequency Band Edges 16

 5.9 Transmitter Spurious Emissions 16

 5.10 6dB Channel Bandwidth (RSS-210) 17

 5.11 Power Spectral Density (RSS-210) 17

6 List of Test Equipment 18

3 Test Information

3.1 Test Facilities

Site 1	9m x 6m x 5.5m Semi Anechoic Chamber	FCC ID IC Certification	183727 4069B-1
Site 2	8m x 4m x 4m Fully Anechoic, Free Space Chamber		
Site 3	9m x 6m x 5.5m Semi Anechoic Chamber	FCC ID IC Certification	183727 4069B-2
Site 4	6m x 3m x 2.5m Screened Room	GND reference plane GND reference plane	1.15 x 2.5m 1 x 2.5m
Site 5	4m x 3m x 2.5m Screened Room		
Site 6	3m x 2m x 2.5m Screened Room		
Site 7	3m x 2m x 2.5m Screened Room		
Site 8	4m x 3m x 2.5 Screened Room	GND reference plane	1.25 x 2.5m
Site 9	6m x 3m x 2.5 Screened Room	GND reference plane GND reference plane	1.25 x 2.5m 1.25 x 2.5m
Site 10	6.5m x 4m x 2.7m Room	GND reference plane GND reference plane	5 x 2m 2 x 1m

3.2 Overall Test Conditions

Work Area	Relative Humidity (%)	Air Pressure (mbar)	Ambient Temperature (°C)
Site 1-5	62	1005	18.9
Sites 6-10	63	1015	21.1

3.3 Test Methods

The objective of the report is to perform testing according to 47 CFR Part 15 Subpart C (Bluetooth and WIFI, 2.4GHz ISM band radiators) for the EUT FCC ID Certification and RSS-210 for the Industry Canada certification:

Number	Standard Number	Document Title
1	47 CFR Part 15 (10-01-09 Edition)	Radio Frequency Devices
2	RSS-210 Issue 8 December 2010	Licence-exempt Radio Apparatus (All Frequency Bands): Category I Equipment

3.3.1 Deviations from Test Methods

None

4 EUT Information

4.1 Test Rationale

Full compliance

4.2 Description of Equipment under Test (EUT)

Date of Receipt:	1-8-11
Client:	Raymarine UK Ltd
Brand Name:	e7D
Product Range:	Multifunction Display with Sonar
Country of Manufacture:	China
Operational voltage range:	10.8V to 18.0V

Unit 1

Model Name or Number:	E62355
Unique Type Identification:	EMC110801b
Serial Number:	0710004
CCT Diagram Number(s) & Issue:	<p><u>Chartplotter Only Variant</u> CPU 4802-003 Issue 8 Sonar IO 4802-008 Issue 4 GPS 1000415 Issue 1 Keyboard 4802-021 Issue 3 Chart Reader 4802-018 Issue 2</p> <p><u>Chartplotter + Sonar Variant</u> Main 4802-002 Issue 8 Sonar IO 4802-007 Issue 4 GPS 1000415 Issue 1 Keyboard 4802-021 Issue 3 Chart Reader 4802-018 Issue 2</p>

PCB Assembly Number(s) & Issue:	<p><u>Chartplotter Only Variant</u> CPU 4802-010 Issue 7 Sonar IO 4802-005 Issue 3 GPS 1000416 Issue 1 Keyboard 4802-022 Issue 3 Chart Reader 4802-019 Issue 2</p> <p><u>Chartplotter + Sonar Variant</u> Main 4802-009 Issue 7 Sonar IO 4802-007 Issue 4 GPS 1000416 Issue 1 Keyboard 4802-022 Issue 3 Chart Reader 4802-019 Issue 2</p>
Software Version:	Platform 0.25 Application 0.25
Modifications to Unit:	<i>TLA2 units hand modified to above standard Radiated Emissions performed on TLA3 Unit</i>

4.3 Additional information

This test report is also applicable to E62354 e7 Multifunction Display

4.4 Description of Auxiliary Equipment

Product Type	Part Number	Serial Number
none		

4.5 Test Configurations

4.5.1 Maximum Power, EIRP Spectral Density and Frequency Range tests

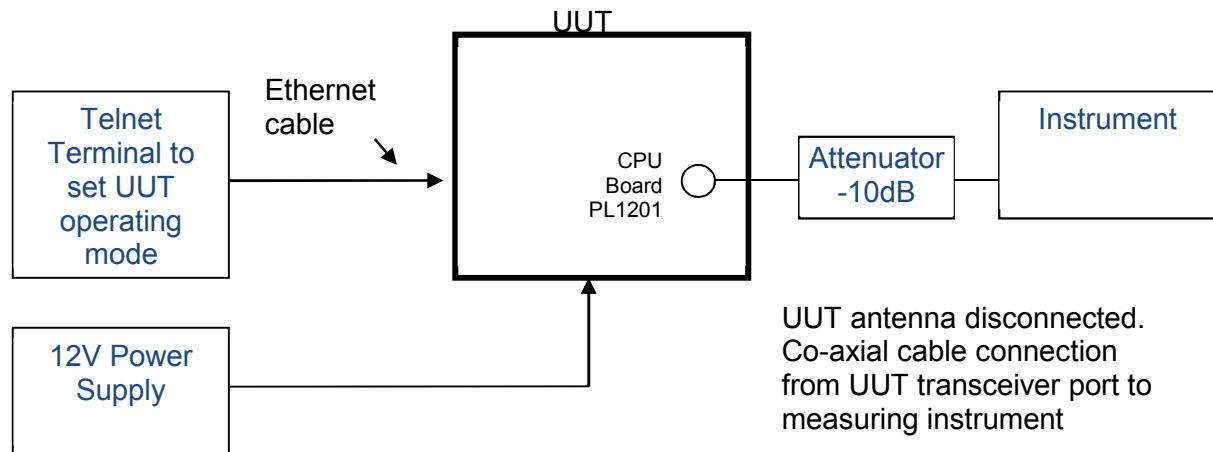

4.6 Operating Modes

4.6.1 Peak Output Power and Frequency Range

The tests performed with the UUT in each of three operating modes:

- Continuously transmitting 802.11b 11Mbps DSSS CCK @ 20dBm nominal
- Continuously transmitting 802.11g 54Mbps OFDM @ 14.5dBm nominal
- Continuously transmitting 1Mbps Bluetooth GFSK, fixed frequency @ 9.5dBm nominal

5 Test Results

5.1 Transmit Duty Cycle, "x"

Transmit duty cycle (symbol "x") is required for the calculations relating average power (measured) to EIRP for Maximum Transmit Power, Maximum EIRP Spectral Density and Frequency Range tests.

UUT Operating Mode	Period (ms)	Transmit On (ms)	Transmit Duty Cycle, x
11Mbps 802.11b DSSS CCK 20dBm nominal	3.0000	1.0000	0.3333
54Mbps 802.11g OFDM 14.5dBm nominal	2.2000	0.2200	0.1000
1Mbps Bluetooth GFSK 9.5dBm nominal	1.0000	1.0000	1.0000

Comments:

Tested by: G Jones

Test Date/s: 09-08-2011

Test Status: INFORMATION

5.2 UUT Antenna Gain, "G"

Antenna gain (symbol "G") is required for the calculations relating average power (measured) to EIRP for Maximum Transmit Power, Maximum EIRP Spectral Density and Frequency Range tests.

UUT Max Antenna Gain (dBi)
-1.0

Comments:

Tested by: G Jones

Test Date/s: 09-08-2011

Test Status: INFORMATION

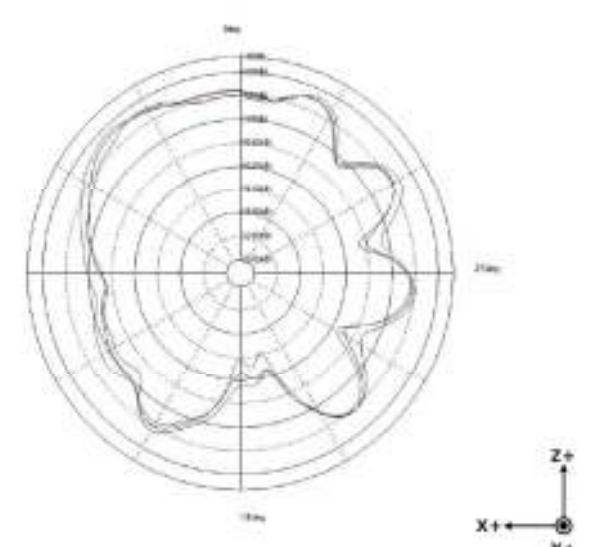
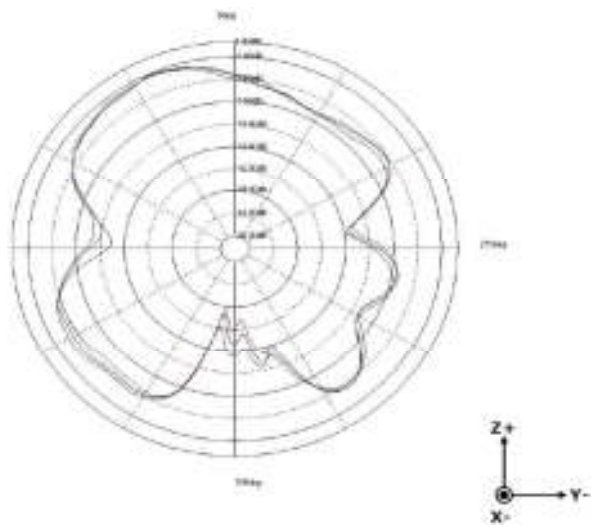
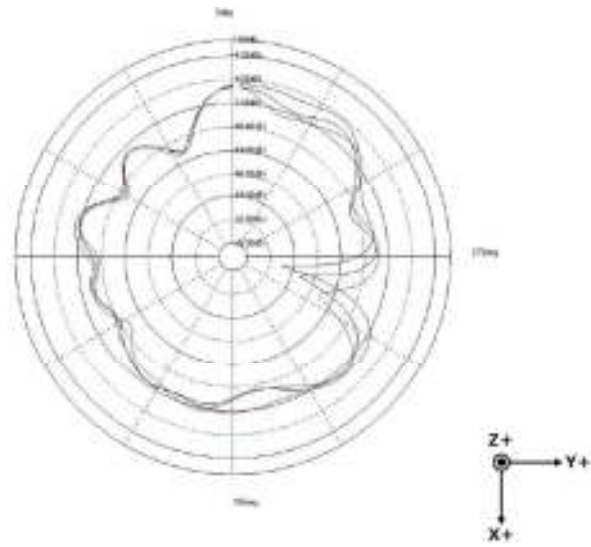

5.3 Peak Output Power

Conducted measurements as specified in 15.247(b)(1).

5.3.1 Normal Test Conditions; 22°C, 12.0V

Operating Mode (Modulation)	Channel \ Frequency (No. \ MHz)	Power Reading (dBm)	Attenuator Correction (dB)	Power Measured A (dBm)	Tx Duty Cycle x	Peak Power (mW)	Limit max. (mW)	Pass/Fail
11Mbps 802.11b DSSS 20dBm nominal	1 \ 2412	-0.1000	10.0000	9.9000	0.3333	29.32005	125	Pass
	7 \ 2442	-0.3800	10.0000	9.6200	0.3333	27.48936	125	Pass
	13 \ 2472	-1.6000	10.0000	8.4000	0.3333	20.757	125	Pass
54Mbps 802.11g OFDM 14.5dBm nominal	1 \ 2412	-11.6600	10.0000	-1.6600	0.1000	6.823387	125	Pass
	7 \ 2442	-12.0400	10.0000	-2.0400	0.1000	6.251727	125	Pass
	13 \ 2472	-13.2700	10.0000	-3.2700	0.1000	4.709773	125	Pass
1Mbps Bluetooth GFSK 9.5dBm nominal	1 \ 2402	-3.4900	10.0000	6.5100	1.0000	4.477133	125	Pass
	48 \ 2480	-3.6900	10.0000	6.3100	1.0000	4.275629	125	Pass
	79 \ 2479	-3.9000	10.0000	6.1000	1.0000	4.073803	125	Pass

Comments:

Tested by: G Jones

Test Date/s: 09-08-2011

Test Status: PASS

5.4 Frequency Hopping Requirements

UUT frequency hopping characteristics are as defined by the Bluetooth system specification

47 CFR 15.247(a)		Bluetooth	Pass / Fail
Technical Specification	Limit		
Dwell Time 15.247(a)	0.4s	0.625ms	Pass
Channel Separation 15.247(a)	Channels non-overlapping, 1MHz separation measured at 20dB below peak power	Complies with this requirement ⁽¹⁾	Pass
Hopping Sequence 15.247(a)	Non-adaptive hopping uses 15 channels min.	79	Pass
	Adaptive hopping uses 90% min. of 2.4000 to 2.4835 band	93%	
	Adaptive hopping uses 20 channels min.	20	
	Each channel occupied at least once during period $T = 4 \times \text{dwell time} \times \text{no. of channels}$	The Bluetooth channel hopping sequence is designed to visit each 1 MHz channel spacing frequency regularly and with roughly equal probability	

(1)

Refer also to Texas Instruments WL1271 (Bluetooth device used in the UUT) datasheet, which confirms channel separation specification measured at 20dB below peak power

Comments:

Tested by: G Jones

Test Date/s: 10-08-2011

Test Status: PASS

5.5 Frequency Range

Conducted measurements as specified in EN 300 328 V1.7.1 (2006-10) clause 5.7.4.1 were used.

Operating Mode (Modulation)	Spectral Power Density Threshold relative to EIRP (dBm, RBW = 100kHz)	Max Antenna Gain, G (dBi)	Tx Duty Cycle, x	Attenuator, Z (dB)	Spectral Power Density Threshold (relative to measured average power) = Threshold relative EIRP - G - 10log(1/x) - Z (dBm, RBW = 100kHz)	fL Ch1 \ 2.412GHz (GHz)	fL limit min. (GHz)	Pass if fL > fL limit?	fH Ch13 \ 2.472GHz (GHz)	fH limit max. (GHz)	Pass if fH < fH limit?	fH - fL (GHz)
11Mbps 802.11b DSSS 20dBm nominal	-30.0000	-1.0000	0.3333	10.0000	-43.7713	2.4027	2.4000	Pass	2.4809	2.4835	Pass	0.0782
54Mbps 802.11g OFDM 14.5dBm nominal	-30.0000	-1.0000	0.1000	0.0000	-39.0000	2.4036	2.4000	Pass	2.4803	2.4835	Pass	0.0767

Operating Mode (Modulation)	Spectral Power Density Threshold relative to EIRP (dBm, RBW = 100kHz)	Max Antenna Gain, G (dBi)	Tx Duty Cycle, x	Attenuator, Z (dB)	Spectral Power Density Threshold (relative to measured average power) = Threshold relative EIRP - G - 10log(1/x) - Z (dBm, RBW = 100kHz)	Ch1 \ 2.402GHz	fL limit min. (GHz)	Pass if fL > fL limit?	Ch79 \ 2.480GHz	fH limit max. (GHz)	Pass if fH < fH limit?	fH - fL (GHz)
1Mbps Bluetooth GFSK 9.5dBm nominal	-30.0000	-1.0000	1.0000	10.0000	-39.0000	2.4013	2.4000	Pass	2.4807	2.4835	Pass	0.0794

Comments:

Tested by: G Jones

Test Date/s: 10-08-2011

Test Status: For Information

5.6 Medium Access Protocol

		UUT
Technical Specification	Requirement	
Medium Access Protocol	A medium access protocol shall be implemented by the equipment	The UUT implements medium access protocols defined by Bluetooth and IEEE 802.11 b/g specifications

5.7 20dB Channel Bandwidth

Modulation	-20dB frequencies		-20dB BW	plot
	fL (GHz)	fH (GHz)	fH - fL (GHz)	
11Mbps 802.11b DSSS 20dBm nominal				
Ch1 \ 2.412GHz	2.40354	2.42054	17.00000	1.wmf
Ch6 \ 2.437GHz	2.42835	2.44546	17.11000	2.wmf
Ch11 \ 2.462GHz	2.45338	2.47054	17.16000	3.wmf
54Mbps 802.11g OFDM 14.5dBm nominal				
Ch1 \ 2.412GHz	2.4017	2.42302	21.32000	4.wmf
Ch6 \ 2.437GHz	2.42589	2.44762	21.73000	5.wmf
Ch11 \ 2.462GHz	2.45104	2.47268	21.64000	6.wmf
1Mbps Bluetooth GFSK 9.5dBm nominal				
Ch1 \ 2.402GHz	2.40118	2.40282	1.64000	7.wmf
Ch40 \ 2.441GHz	2.44018	2.44182	1.64000	8.wmf
Ch79 \ 2.480GHz	2.47918	2.48082	1.64000	9.wmf

5.8 Frequency Band Edges

Modulation	-20dB frequencies	
	fL (GHz)	fH (GHz)
11Mbps 802.11b DSSS 20dBm nominal		
Lower Band Edge Ch1 \ 2.412GHz	2.40354	
Upper Band Edge Ch11 \ 2.462GHz		2.47054
54Mbps 802.11g OFDM 14.5dBm nominal		
Lower Band Edge Ch1 \ 2.412GHz	2.4017	
Upper Band Edge Ch11 \ 2.462GHz		2.47268
1Mbps Bluetooth GFSK 9.5dBm nominal		
Lower Band Edge Ch1 \ 2.402GHz	2.40118	
Upper Band Edge Ch79 \ 2.480GHz		2.48082

5.9 Transmitter Spurious Emissions

Covered in separate Report

5.10 6dB Channel Bandwidth (RSS-210)

Modulation	-6dB BW (MHz)	Limit	
11Mbps 802.11b DSSS 20dBm nominal		>500kHz	
Ch1	8.62		Pass
Ch7	6.99		Pass
Ch13	7.02		Pass
54Mbps 802.11g OFDM 14.5dBm nominal			
Ch1	16.38		Pass
Ch7	16.21		Pass
Ch13	16.48		Pass

5.11 Power Spectral Density (RSS-210)

Modulation	PSD dBm	Limit dBm	
11Mbps 802.11b DSSS 20dBm nominal		<8dBm	
Ch1	-19.96		Pass
Ch7	-17.51		Pass
Ch13	-18.99		Pass
54Mbps 802.11g OFDM 14.5dBm nominal			
Ch1	-31.07		Pass
Ch7	-29.57		Pass
Ch13	-31.25		Pass

6 List of Test Equipment

Test Equipment Type	Manufacturer and Type Number	Serial Number	Cal No.	Cal Due
Power Meter	Agilent E4419B		02079	14.10.2011
Power Supply Unit	Palstar PS30M	G290775401	02020	not cal'd
Digital Multimeter	Fluke 85	65690477	00618	13.10.2011
Peak Power Analyser	HP 8991A		00318	14.10.2011
EMI Receiver 20Hz to 26.5GHz	Rohde & Schwarz ESI26	832692/006	00886	3.6.2012
Antenna Horn 1-18GHz	Chase BBHA9120D	9120D-578	01719	12.10.2011
Antenna Mast (Site 1)	Inn-co GmbH MM4000	MM4000/056/13750 806/L	02075	N/A
Turntable (Site 1)	Inn-co GmbH DS1200S	DS1200S/175/1375 0806/L	02076	N/A
Mast/Turntable Controller (Site 1)	Inn-co GmbH Co 2000	CO/2000/359/137/5 0806/L	02077	N/A
EMI Receiver 20Hz to 40GHz	Rohde & Schwarz ESU40	100017	01721	31.01.2012
Power Supply Unit	Palstar PS30M	G450673928	01935	N/A

In accordance with UKAS requirements, all measuring equipment is on a calibration cycle.