

RD218 2kW and RD424 4kW

Radome Radar Scanners

Technical Description

CONTENTS

1	Overview	2
1.1	Scanner Configuration	2
1.2	Low Noise Front End/Limiter (LNC)	3
1.3	IF Receiver Board	4
1.3.1	<i>Main Receiver</i>	4
1.3.2	<i>Autotune Receiver</i>	5
1.3.3	<i>STC/Main Bang Suppression (MBS)</i>	5
1.4	MOD/PSU and Control Board	6
1.4.1	<i>Input Filter/Protection</i>	6
1.4.2	<i>PSU</i>	6
1.4.3	<i>Modulator</i>	6
1.4.4	<i>Stepper Drive</i>	6
1.4.5	<i>Micro controller</i>	7

1 OVERVIEW

1.1 Scanner Configuration

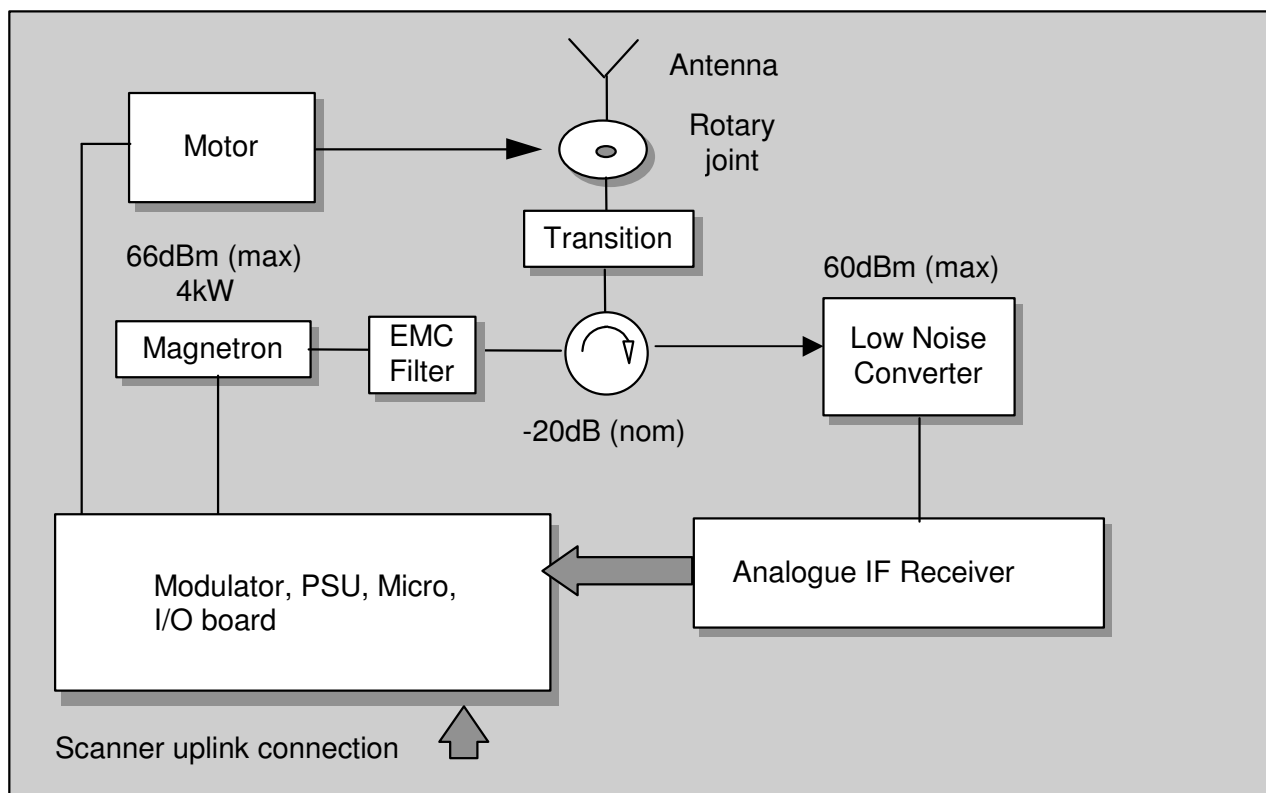

Figure 1 Scanner Block Diagram

The system comprises the functional blocks as shown in the above diagram. The basis of operation is described below.

The **Modulator, PSU board** generates a high voltage but low current pulse of between 75ns and 1.0µs dependent upon the range setting. This pulse starts on the rising edge of a negative going trigger at a pulse repetition frequency (PRF) also defined by the range setting. The resulting DC pulse is output to the **magnetron** which converts the DC energy into an RF pulse at a frequency of 9.41GHz (nominal).

All power supply requirements are also provided by the **Modulator, PSU board**. It also provides the interface for the power and I/O connections from the Radar display.

The RF pulse is routed to an **antenna** via a 3-port **circulator** which propagates microwave energy in only one direction and thereby provides isolation between the transmit source and the **low noise converter**. The circulator assembly also include a filter structure and isolator to maintain compliance with unwanted emissions regulations.

A rotary joint is used to maintain continuity between a waveguide output from the circulator and a microstrip input to the antenna. This is achieved via transitions into, and back out of a section of co-axial line which is configured with a 'split' perpendicular to the axis of rotation. The energy is then radiated by the antenna with a narrow azimuth beam shape (5.1° for the 18" antenna, 4.5° for the 24" antenna), with low sidelobe levels. The elevation beamwidth is maintained at approximately 25° in order to illuminate targets during pitch and roll of the transmitting vessel.

Echoes are returned due to reflections from potential targets such as boats, buoys, land etc, and in the form of clutter from sea, rain, etc.

The returned energy is collected by the same *antenna* used to transmit the original pulse and is routed through the *circulator* to the *low noise converter (LNC)*. These comparatively low level signals are amplified in a low noise transistor in order to maintain signal/noise performance, and mixed down to an IF frequency of 60MHz nominal for further amplification and subsequent detection.

The *IF receiver board* provides further low noise amplification with a wide dynamic range detector, and a dynamic video attenuation control is provided to maintain target detectability in the presence of clutter, target and range variations.

The *IF receiver* board logarithmic detection stage has approximately 85dB instantaneous dynamic range, which provides a compressed signal output in terms of dB input power versus output Voltage level.

Various filtering stages are also employed in the *IF Receiver* to provide optimum signal/noise characteristics for the detected pulse and to provide some immunity against the bulk effects of rain.

1.2 Low Noise Front End/Limiter (LNC)

The primary function of the LNC is to provide low noise amplification of the low level signal returns and mixing to an IF frequency of 60MHz nominal.

The low noise amplification is provided by a low noise FET set at bias conditions, and with associated matching which minimise noise figure and maximise gain and compression levels. Maximum gain is required so as to minimise the noise figure contribution from subsequent stages. The mixing function is carried out in an image reject mixer configuration which reduces image noise by 15dB nominal in order to minimise the degradation in overall noise figure.

Protection is provided in the form of three limiter diodes which are configured to become forward biased in the presence of increasing RF power. The LNC is capable of withstanding an input level of 60dBm.

:

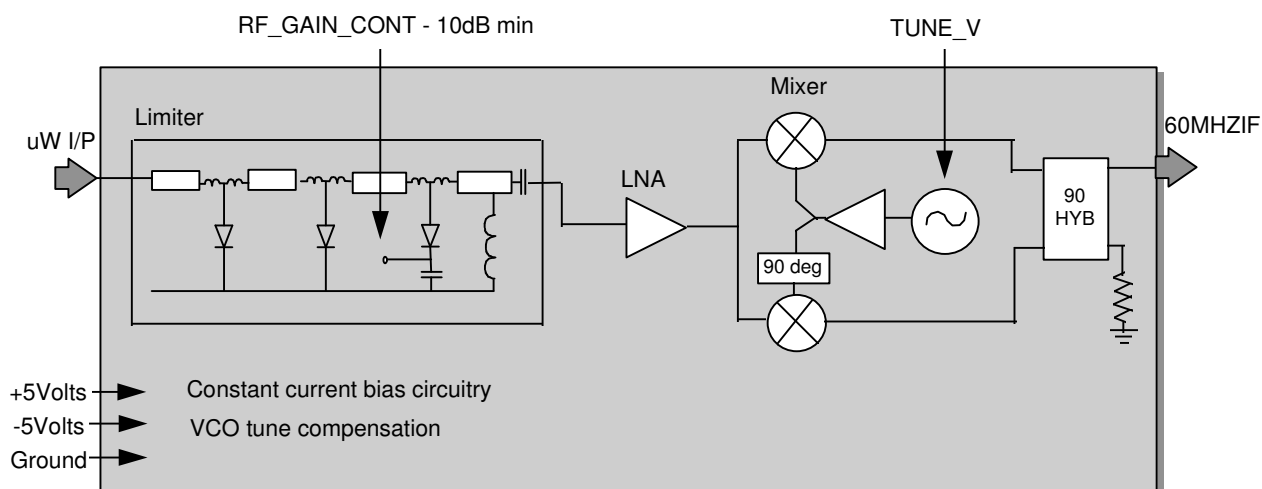

Figure 1-1 LNC block diagram

1.3 IF Receiver Board

1.3.1 Main Receiver

The receiver provides low noise amplification via a discrete transistor based gain stage followed by a selectable IF bandpass filter stage tuned by the means of adjustable inductor coils.

The IF filter stage is configured to provide matched filtering for the shorter 80ns and 250ns pulses respectively by switching between 12MHz and 3MHz. Gain is increased accordingly to maintain a relatively constant noise power at the receiver output.

A switched video filter is used in conjunction with the 3MHz IF filter to provide matched filtering for the longest 600ns and 1µs pulses. These are 0.7MHz and 0.5MHz wide

A 'fast time constant' circuit is also used to provide a continuously variable high pass filter to provide some immunity against the bulk effects of rain.

Figure1-2 – Analogue IF receiver Block Diagram

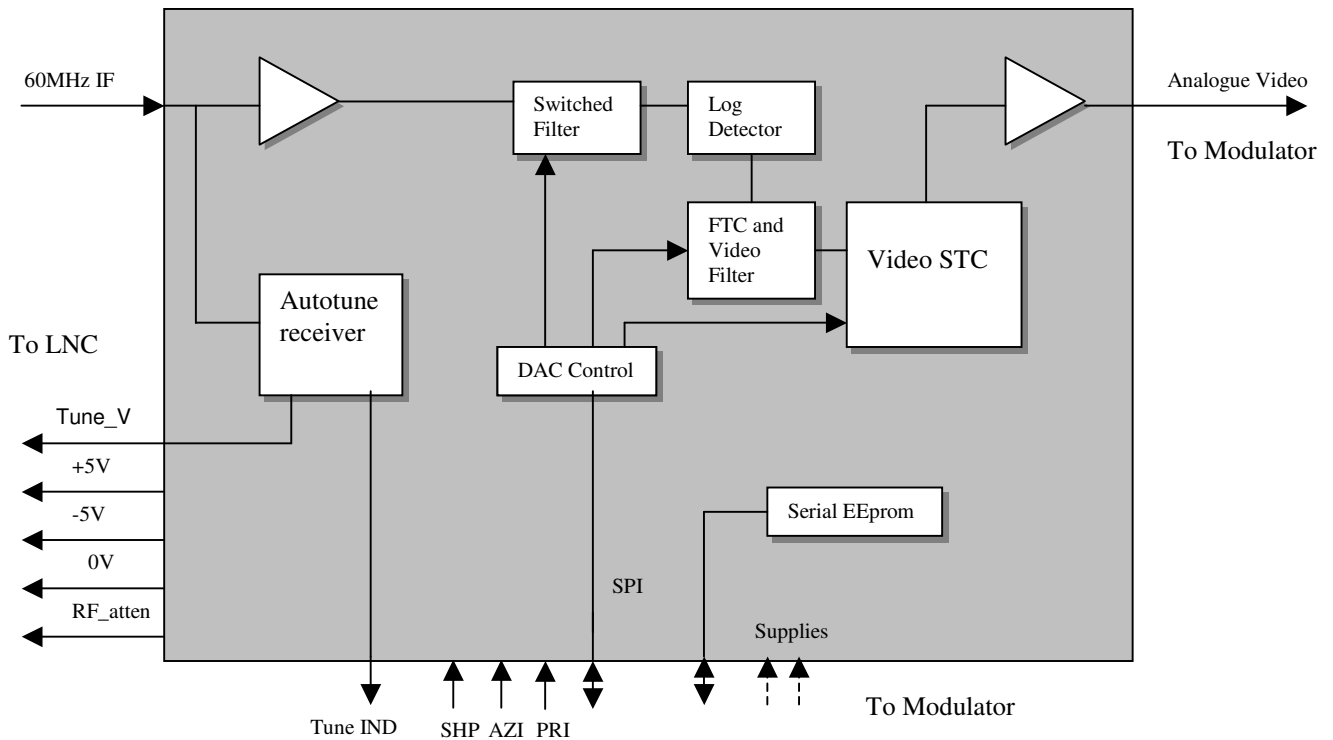

1.3.2 Autotune Receiver

The autotune receiver provides frequency selective peak detection of high level 'main-bang' transmitter pulses. This is achieved using a high impedance branch from the main receiver input with a transistor/diode based amplifier/detector circuit. The output of the receiver is buffered and passed to the scanner microprocessor. A tuning algorithm is performed by the display to set the difference frequency between the magnetron and VCO (Voltage Controlled Oscillator) to a fixed IF frequency of 60MHz. Both coarse and fine adjustment are provided by the microprocessor to allow for initial setting and subsequent fine tuning.

1.3.3 STC/Main Bang Suppression (MBS)

The STC circuitry consists of a logarithmic function generator split into three main outputs and with fixed multipliers of 4 and 2 to generate the R^4 and rain curves and a variable (16 selectable levels) multiplier to generate the Sea clutter curve.

These curves are offset as requested via processor/operator demands and then combined to provide an output equal to the greatest of the inputs. In addition an "STC knee" control is cascaded on the output to provide a "ceiling" for the maximum allowable level of attenuation (in practice this is a previously determined level preset under software control).

Main Bang Suppression (MBS) is provided in the form of a fixed level, variable delay attenuation circuit which is used to blank the received transmit leakage pulse into the IF receiver.

The combined STC attenuation curve and MBS attenuation pulse are summed and used to control the gain of the video output amplifier, hence imposing the gain profile onto the received signal before output to the display.

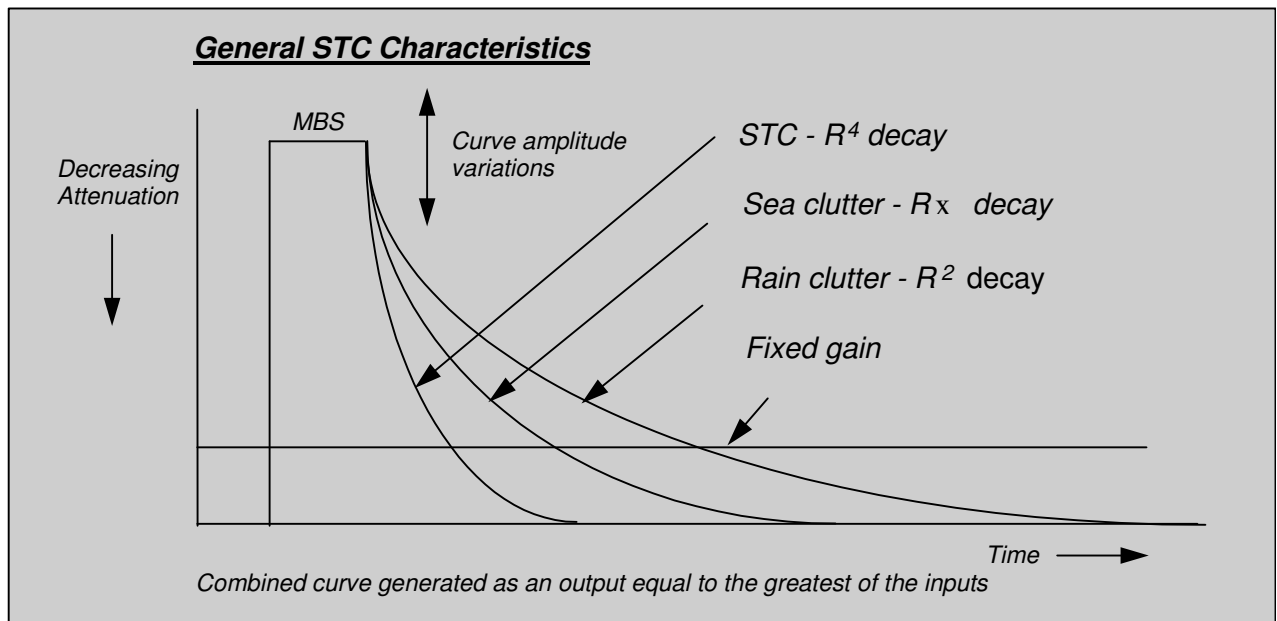

Figure 1-3 General STC Characteristics

1.4 MOD/PSU and Control Board

1.4.1 Input Filter/Protection

The ship's d.c. supply comes onto the board through SKT1 and goes straight into the lightning/surge protection and EMC filter circuits.

Next TR37 and 38 along with IC17-C and D Provide both reverse polarity and inrush/overcurrent protection. (The latter prevents fire hazard in the event of a short circuit inside the supply).

IC17-A and B monitor the incoming supply and generate undervoltage lockout and power fail signals according to the voltage.

1.4.2 PSU

The heart of the PSU is a flyback converter, the design of which is very largely based on that used in previous generations of modulators. Separate transformer windings provide +12V, +5V, +3V3, +350V and the magnetron heater supply. +26V and -5V are generated by a charge pump circuits. Many of the supply rails are used within the Mod/PSU as well as externally on the IF board and either LC or RC filtering is provided on all IF supplies to isolate any locally generated noise.

The converter runs under the control of IC15 which gets its supply from a current source from the internal rail Vgate. Before the converter is running Vgate will be a diode drop below Vp but once the converter starts it will be around 12V above. This allows the converter to continue to operate with input voltages below the minimum supply voltage for the UCC3800. (Vgate is also used to provide the gate voltage to the inrush/protection FET).

Feedback comes from the 3V3 rail or, if connected 3V3 sense so all other outputs are only loosely regulated except for the magnetron heater supply where IC7 gives a constant current of 0.6A.

ISO3 Provides overvoltage protection in the event of the failure of the normal feedback circuit.

1.4.3 Modulator

The high power section of the modulator circuit consists essentially of the pulse transformer TX1 and the IGBT TR29. TR29 switches on for the required pulse duration, which applies 350V across the primary winding of TX1; this gets stepped up to the 4kV required to fire the magnetron by the transformer. D1 and C1 limit the rate of rise of voltage (RRV) and D2 and R4 provide a reset mechanism for the transformer.

The mechanics of the magnetron dictate that the anode is connected to chassis and the implication of this is that the magnetron voltage (pulse) needs to be applied to the cathode with the heater supply (constant dc) superimposed on top. This is achieved by way of the two closely coupled high voltage transformer windings.

Pulse timing control comes from the monostable IC11 and associated circuitry. This essentially outputs a pulse width that is defined by the time constant of C31, C22 and the resistors R255, R56, R77, R76 and R247. These resistors are switched in and out under software control so that the pulse width can be varied across the required 75ns to 1.0uS range. The monostable chip IC11 uses internal compensation to remain immune to supply/temperature variation.

The system requires the ability to switch quickly between two power levels for the dual range functionality. Power control is achieved by adjusting the supply voltage to IC5. This supply is controlled by op-amp IC13 with a push pull output stage of TR25, TR26 and DAC reference input. The push pull put stage allows the voltage to be adjusted quickly for dual range functionality.

1.4.4 Stepper Drive

This circuit is essentially a set of 4 darlington transistors (inside IC1) which buffer the control signals generated by the micro to drive the motor windings. The outputs are open collectors.

There is also an enable input, which is controlled by the micro but which may also be driven via the IF interface.

1.4.5 Micro controller

The Micro controller on the MOD/PSU controls the adjustable functionality of the scanner. This is based on commands sent to it via an RS485 communications port from an external device, usually a Radar display. This is a ASCII text based protocol, used on an RS485 link running at 19.5k baud, seven data bits, even parity, one start bit, two stop bits.

The micro is connected to a non-volatile memory device IC12 that holds default and start-up information.

The Micro controls the speed of the stepper motor by producing timed pulse trains to the stepper motor drive hardware. When the appropriate command is received the motor speed is ramped up until the desired antenna speed is reached.

The functions of the modulator are under control of the micro through a DAC (IC19) and several digital control lines. The DAC is used to control Modulator power output and fine control of the pulse width. The digital lines are used to produce the PRF and coarse pulse width settings. All of the modulator settings are either controlled via the RS485 communications port or are stored in the non-volatile memory.

There is a DAC in the IF (IC1) that is controlled by the MOD/PSU micro controller. This DAC controls the analog functions of the IF based on commands from the RS485 communications port and the non-volatile memory.

There are two timing signals that go through buffers to the external display device, the AZI and PRI signals. AZI is a timing signal based on the motor speed and indicates the location of the antenna so the display can display the appropriate spoke position. The PRI signal gives the display the PRF clock signal required to synchronise the display of the radar video information.

There are several other input and output signals that are used to sense the state of the system and ensure proper operation and emergency shut down. The TX_EN signal is used to quickly and safely enable/disable transmission at start up, during a fault condition or under control of the RS485 communication port. The SHP signal receives a pulse once per revolution of the antenna, if this signal stops then transmission is disabled. The PWR_FAIL signal is an early warning of imminent power supply failure, this gives the micro time to disable transmission, finish any non-volatile writing required and then idle in a known state to avoid data loss.

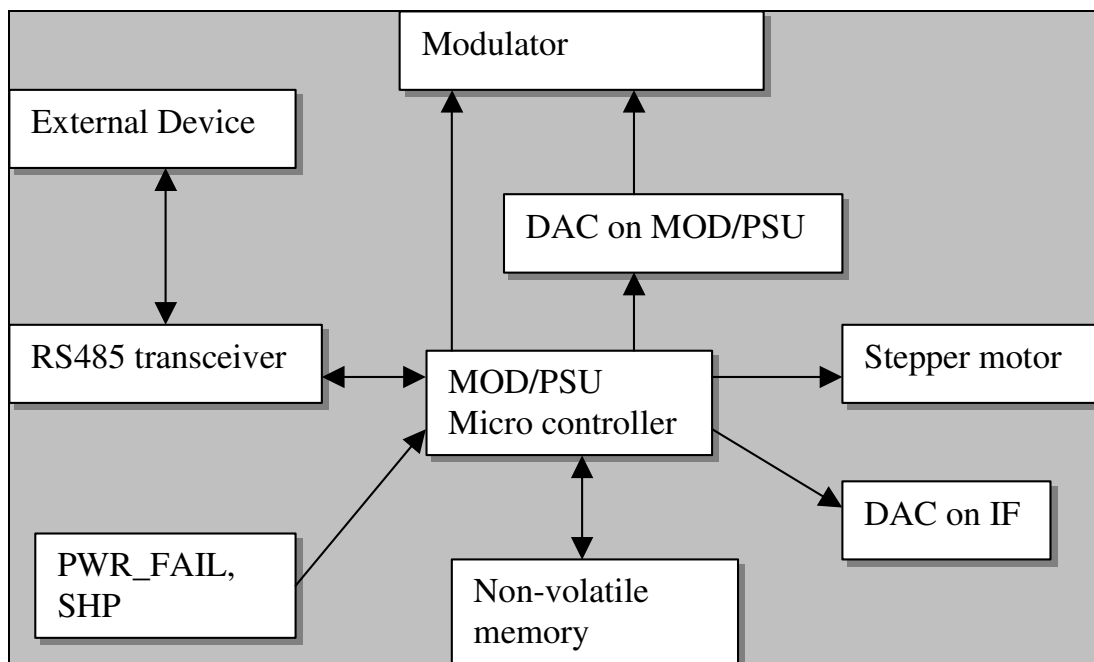

Figure 1-4 Modulator, PSU and micro controller board block diagram