

Short J3,J4

SHORT	Frequency
J3 J4	27.145MHz
J2 J4	40.685MHz
J1 J2	49.860MHz

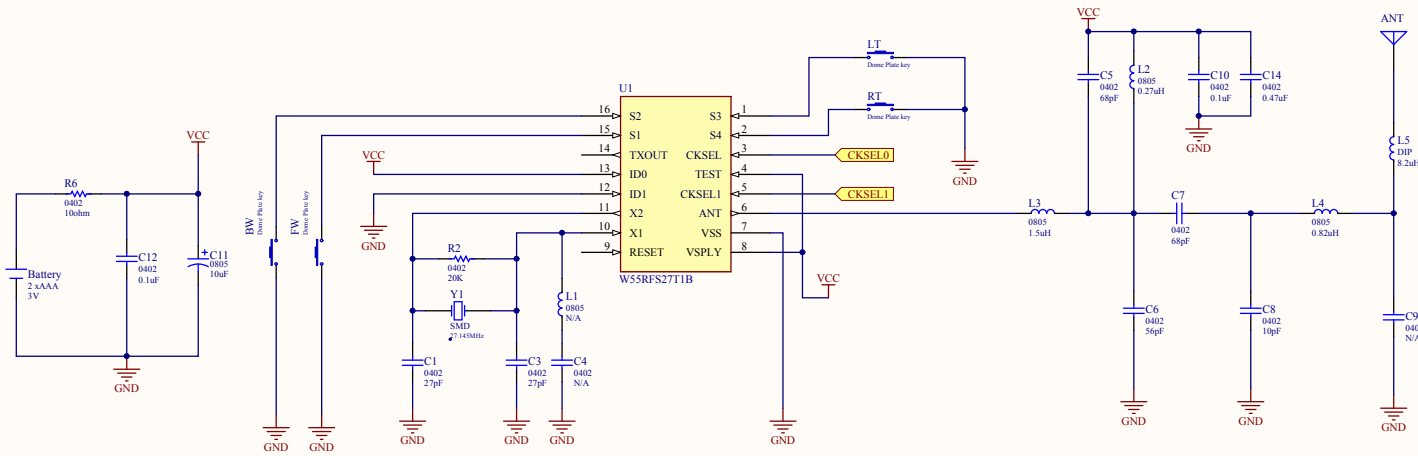

ID1 : ID0 = 0 0 = Data rate = 2.5KBPS
 ID1 : ID0 = 0 1 = Data rate = 1.25KBPS
 ID1 : ID0 = 1 0 = Data rate = 0.625KBPS
 ID1 : ID0 = 1 1 = CPU mode

TX:27MHz

Standard Common part for master

Capacitor (1st priority)	
No:	Part Value
1	10PF chip 50v +80-20% SMD 0603
2	20pF chip 50v +80-20% SMD 0603
3	25pF chip 50v +80-20% SMD 0603
4	1000pF chip 50v +80-20% SMD 0603
5	0.1uF chip 50V +80-20% Y5V, 50V SMD0603 0.1uF 25V +80-20% Y5V, PKG: Ceramic dia 6mm x 3.5
6	0.033uF 25V_Y5V_PKG: dia 4mm x 3.5
7	10uF 25V +/-20% AL EL PKG:5x11mm
8	47uF 25V +/-20% AL EL PKG:5x11mm
9	100uF 25V +/-20% AL EL PKG:5x11mm
10	220uF 25V +/-20% AL EL PKG:5x11mm
Resistor:	
1	10 ohm +/-5% 0603
2	100 ohm +/-5% 0603
3	1K ohm +/-5% 0603
4	4.7Kohm +/-5% 0603
5	10k ohm +/-5% 0603
6	47k ohm +/-5% 0603
7	100kohm +/-5% 0603
8	220k ohm +/-5% 0603
9	1M ohm +/-5% 0603
10	2.2M ohm +/-5% 0603
Diode:	
1	IN4001PKG: DO-41 50V
2	IN4148 PKG: DO-35 50V
3	IN5817: DO-41 50V
4	BAT54 SOT23 30V
Transistor	
1	S8050NPN (1.5A)SOT-23.V: 40; W: 0.3;
2	S8550D PNP(1.5A)SOT-23.V: 40; W: 0.3;
3	S9014D NPN (1.5A)SOT-23.V: 40; W: 0.3;
4	B772 PNP A: 3; V: 40; Max. W: 1.25; PKG: TO-126;
5	D882 NPN A: 3; V: 40; Max. W: 1.25; PKG: TO-126;
Inductor	
1	Choke Coil DESC: 5.6uH 10% 1/2W
PTC	
1	MF-R400-0-99

Non Standard parts Guide Line (2nd priority)
 Using E3 value for resistor, capacitor and inductor
 Standard IEC E3 Decade Value = 100, 220 & 470
 Non Standard parts Guide Line (3rd priority)
 Using E6 value for resistor, capacitor and inductor
 Standard IEC E6 Decade value =100,150,220,330,470 & 680



TEST MODE:	REMARKS:	IC information: 1.operating voltage:2.2V-5.5V 2.Standby current is 1uA 3.DATA rate is 1.25Kbps	History
1	2	3	4

Size A3	Number W5756	Project Name RC BATMAN FULL FUNCTION	Revision R0
Date 12/29/2011	Sheet of		
File : D:\model\RC\mod\by model\W5756\W5756 TX.sch R0 20110823 SchDoc			