



×

THE  
**BATMAN**™  
DC

The Ultimate BATMOBILE™ Experience



ADULT COLLECTOR

USER GUIDE



Congratulations on this one-of-a-kind experience. You've unlocked a unique Batman™ collector's item in an exceptional Hot Wheels® RC. This sleekly designed Batmobile™ has been carefully crafted with authentic features from The Batman™ movie. It exudes all the cool that you know and love in a Batmobile™, while transporting you via a unique sensory experience that you can't help but want to display.

### OUTDOOR USE RECOMMENDED.

Keep these instructions for future reference as they contain important information.

**IMPORTANT:** Please read all instructions before operating your vehicle.

### CAUTION:

Surfaces may become hot and cause burns if electronics get wet. To prevent entanglement, keep all hair away from moving parts.

Adult supervision is recommended when the vehicle is being operated.

The toy is only to be connected to Class II equipment bearing the symbol .

## 1: CONTENTS

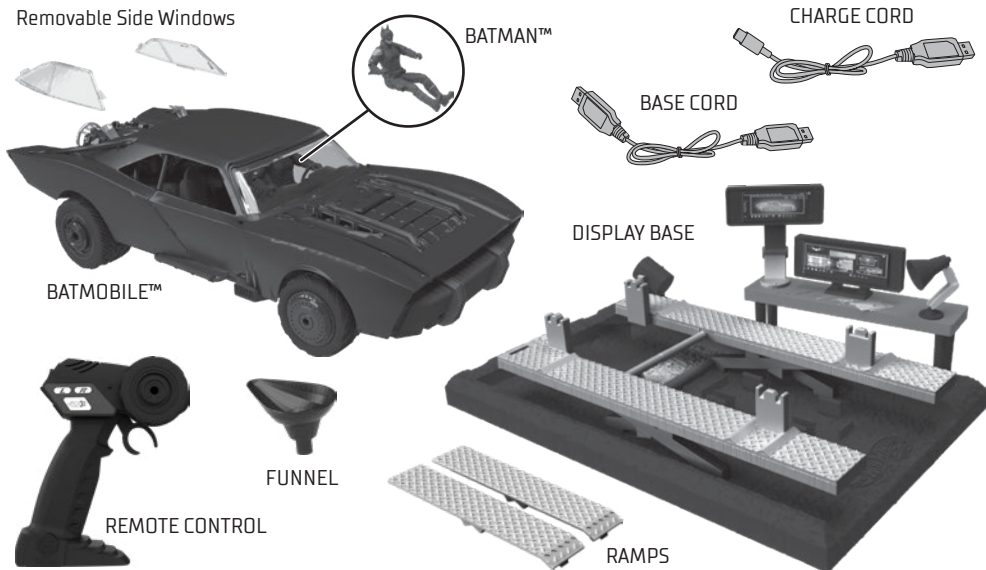

## 2: FEATURES

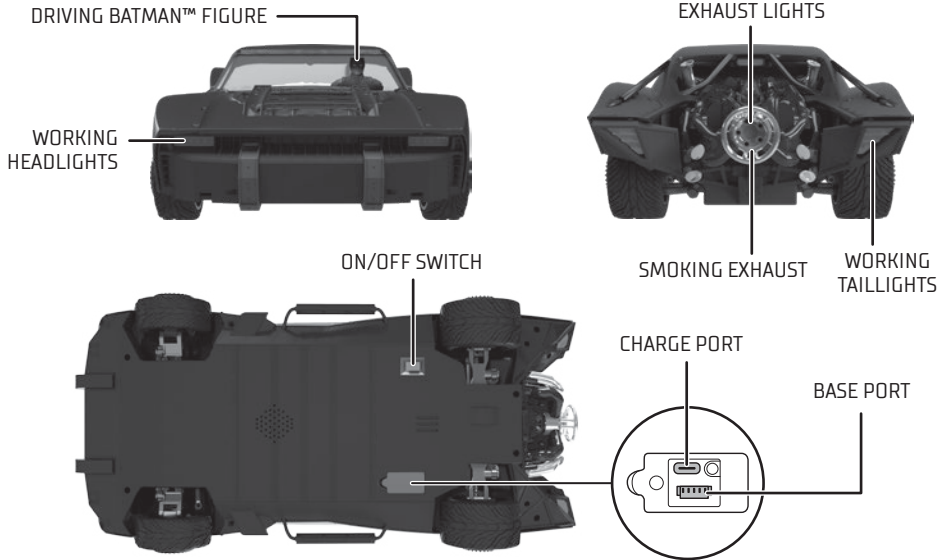

Attach ramps to the base.

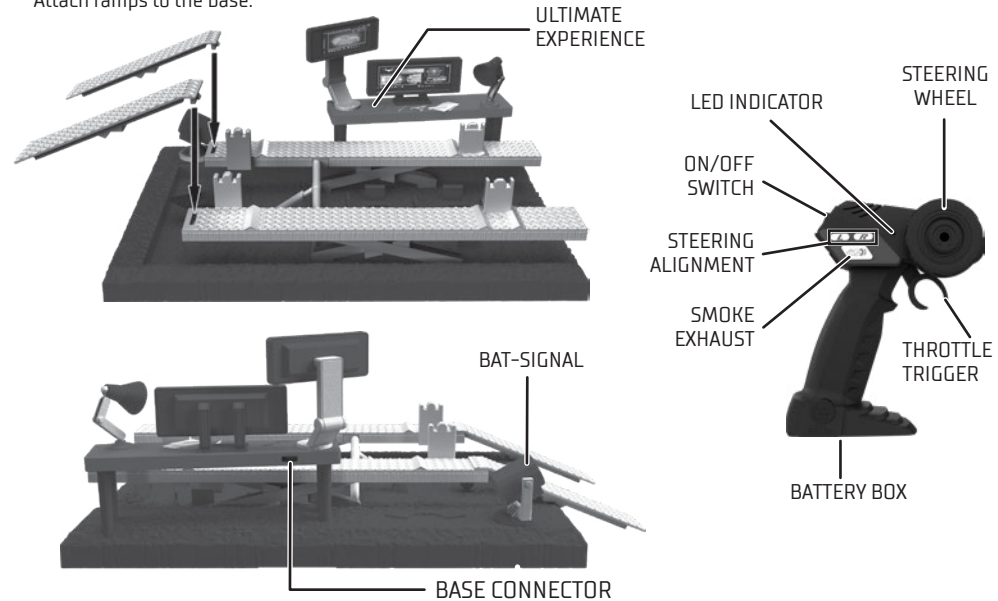

### 3: SET UP

#### A. CHARGING THE VEHICLE

The vehicle is powered by a permanently installed Lithium-ion (Li-ion) battery, and it must be fully charged before first use.

1. Switch off the vehicle by sliding the power switch to OFF (0/⚡).
2. Remove the port cover and connect one end of the charge cord to the vehicle's charge port and plug the other end in to a 5V/1000 mAh USB charger (not included). The blue LED by the charger connector box will light up when it is connected to a USB charger.
3. The blue LED will slowly flash as the vehicle is charging.
4. When the vehicle is fully charged, the blue LED will stop flashing and remain on. Unplug the cord when charging is complete. A full charge will take approximately 4 to 5 hours. Charging time may vary.
5. Consider recharging the vehicle when the FORWARD/BACKWARD controls on the vehicle become disabled, as this means the battery level is running low. If the vehicle's headlights suddenly flash for approximately 10 seconds, this means the vehicle's battery is empty. The vehicle will shut off immediately and must be recharged.

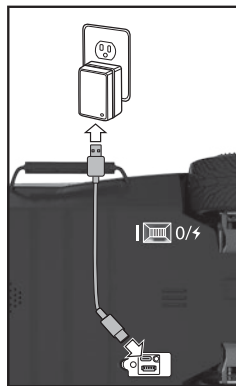
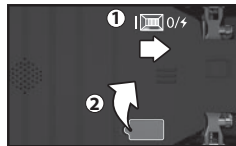
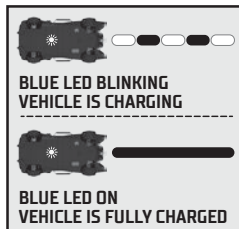

#### B. REMOTE CONTROLLER BATTERY INSTALLATION

1. Unscrew the battery cover with a Phillips head screwdriver (not included).
2. Install 2 AA (LR6) 1.5V alkaline batteries (not included) with polarity (+/-) as shown inside the battery compartment. For best performance, use alkaline batteries.
3. Replace battery cover and tighten screw.
4. Replace batteries in the remote controller if the vehicle does not respond well after a recharge or if you see a red light slowly flashing for approximately 10 seconds in the LED indicator during play.

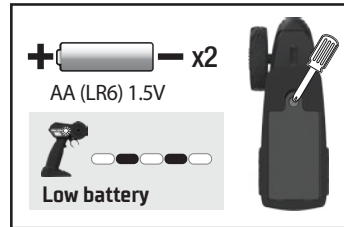

#### TIPS:

- The power switch must be in the OFF (0/⚡) position when charging the vehicle.
- The vehicle and remote controller will go into sleep mode if left idle for approximately 5 minutes to preserve battery life. To resume normal play, slide the vehicle's power switch to OFF then back to ON and move one of the remote controller's driving controls.
- Charging the battery for more than what is recommended will not give you a longer running time.
- The battery will be hot after play. Wait at least 10 to 15 minutes until the battery cools down before recharging the vehicle.
- It is recommended that you remove all the batteries from the remote controller and leave the vehicle's battery fully charged but switched OFF before storage.

### C. PAIRING THE REMOTE CONTROLLER AND VEHICLE

1. Slide the power switch to the ON (I) position on the vehicle.
2. Switch the remote controller on after switching on the vehicle.
3. Pairing is complete when the vehicle's headlights and the remote controller's lights stop flashing and remain on.

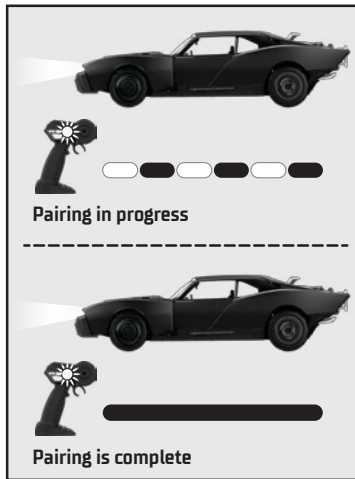
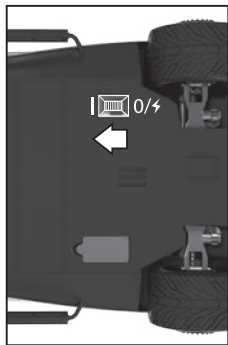

### D. STEERING ALIGNMENT

1. Drive the vehicle forward to see if it is driving straight.
2. If the vehicle automatically steers toward the right/left, press the alignment button in the opposite direction a few times until it runs in a straight line.



**NOTE:** If the LED indicator does not stop flashing in approximately 10 seconds, switch off the vehicle, turn it back on, and then switch the remote controller off and on to try pairing again.

## 4: HOW TO DRIVE

### CHECKLIST

- Is the vehicle's battery fully charged?
- Is the remote controller equipped with fresh batteries?
- Is the remote controller paired with the vehicle?
- Has the vehicle's steering been aligned?

### CONTROLS

Use the throttle trigger to drive forward and backward. Rotate the steering wheel as the Batmobile™ is moving to turn left/right.

**NOTE:** Operating range of the remote controller is up to 50 m [164 ft].

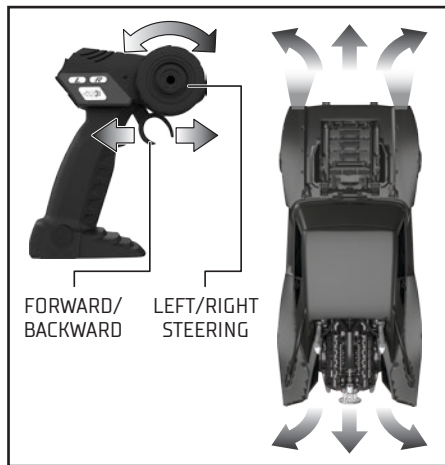

### SKILL CHECK!

Remember, turning directions are flipped on the remote controller when you are driving backward!

## SMOKE EXHAUST

1. Locate the smoke chamber. Lift the lid and use the funnel to fill the chamber with clean water. Close the lid once the chamber is filled.

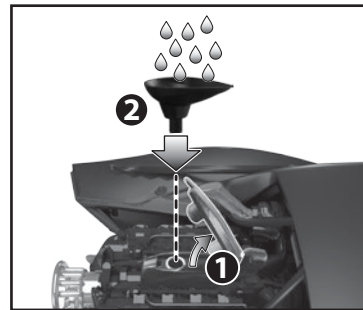

2. Press the smoke exhaust button on the remote controller to release smoke!

### IMPORTANT:

To prevent damages to the vehicle:

- DO NOT overfill the smoke chamber.
- NEVER directly fill the smoke chamber under a tap or immerse vehicle under water as it will cause damage to the vehicle.
- DO NOT turn the vehicle upside down when it is filled with water as it may cause leakage.

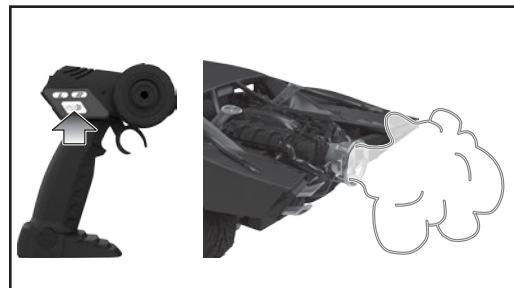

## DISPLAY BASE

1. Connect one end of the base cord to the vehicle's base port and connect the other end to the display base.

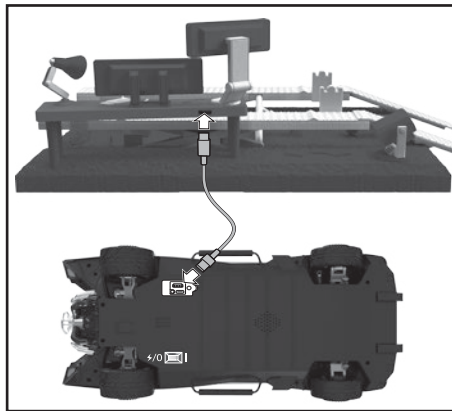

2. With the Batmobile™ connected to the base, press the Ultimate Experience button to activate the Bat Signal and Batmobile™ lights, sounds, and action.

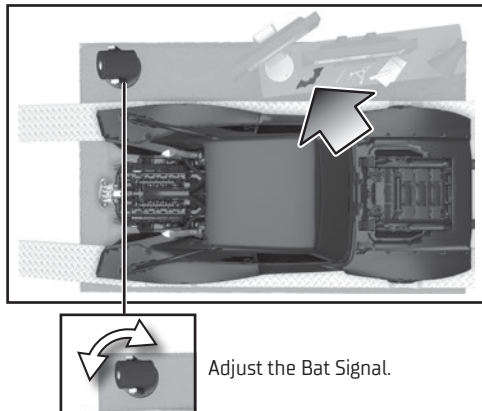

**NOTE:** The display base's features can only be activated when the Batmobile™ is connected. For best experience, make sure the Batmobile™'s battery is charged before connecting it to the base.

## 5: CONSUMER INFORMATION

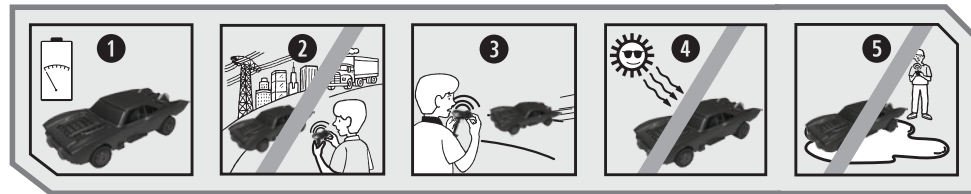

### TIPS & HINTS – FOR ALL DRIVING ENVIRONMENTS

1. When your vehicle starts to lose power, it may lose functionality or performance. It's time for a recharge. For best performance, always start with a fully-charged battery. Your vehicle's running time may change depending on driving style and driving environment.
2. Radio interference can make your vehicle run poorly. Interference can be caused by other RC vehicles running on the same frequency, electrical wires, large buildings, CB radios, or other wireless gear. Try to stay away from these!
3. Point your remote controller up, and not down toward your vehicle. If your vehicle gets too far away, it won't work properly.
4. Don't store your vehicle near heat or in direct sunlight. Always turn switches OFF and remove all batteries from the remote controller before storage.
5. Don't drive your vehicle in sand or through water or snow. Do not immerse in water. If your vehicle does get wet, wipe it with a towel and allow to dry completely overnight. If your remote controller is accidentally dropped in water, remove battery(ies) and allow your remote controller to air-dry. Replace with fresh battery(ies) before operation.
6. When exposed to an electrostatic source, the remote controller and/or the vehicle may malfunction. To resume normal operation of the remote controller, remove the batteries and reinstall them after 5 seconds. To resume normal operation of the vehicle, turn the power OFF for 5 seconds, then turn it ON again.
7. For extended storage, make sure to charge the battery before storing so that the battery does not become depleted over time. The battery should be charged once a year if the vehicle is to remain in storage.

## SAFETY TIPS

- Play safely! Do not drive the vehicle in the street!
- DO NOT pick up the vehicle while in motion.
- Keep fingers, hair, and loose clothing away from the wheels while the vehicle is switched ON.
- Adult supervision is recommended when this vehicle is being operated.
- To avoid accidental operation, remove all batteries from the remote controller when not in use and switch the vehicle OFF before storage.

## RECHARGEABLE BATTERY SAFETY INFORMATION

- This toy contains batteries that are non-replaceable.
- Rechargeable batteries are only to be charged under adult supervision.
- Do not recharge the battery if it is hot. Allow it to cool before recharging.
- Do not recharge a battery pack that shows leakage or corrosion.
- Do not disassemble the battery pack. The battery pack is a sealed rechargeable Li-ion battery pack.
- If the battery pack and/or charging port are wet, thoroughly dry before charging.
- Do not recharge non-rechargeable batteries.
- The Li-ion battery in the vehicle is not intended to be replaced or removed by consumers. Before disposal in the waste stream, the Li-ion battery must be removed by a qualified professional and disposed of separately according to local regulations on battery collection and recycling.
- Do not dispose of the batteries in a fire.
- Rechargeable batteries are to be recharged with the charger included in the package.
- Rechargeable batteries should be fully charged before placing in storage. Do not store depleted batteries.



## BATTERY SAFETY INFORMATION

In exceptional circumstances, batteries may leak fluids that can cause a chemical burn injury or ruin your product. To avoid battery leakage:

- Non-rechargeable batteries are not to be recharged.
- Rechargeable batteries are to be removed from the product before being charged.
- Rechargeable batteries are only to be charged under adult supervision.
- Do not mix alkaline, standard (carbon-zinc), or rechargeable batteries.
- Do not mix old and new batteries.

- Only batteries of the same or equivalent type as recommended are to be used.
- Batteries are to be inserted with the correct polarity (+ and -).
- Exhausted batteries are to be removed from the product.
- The supply terminals are not to be short-circuited.
- Dispose of battery(ies) safely.
- Do not dispose of this product in a fire. The batteries inside may explode or leak.

## FOR PRODUCT SOLD IN USA

This device complies with Part 15 of the FCC Rules. Operation is subject to the following two conditions:

(1) This device may not cause harmful interference, and (2) this device must accept any interference received, including interference that may cause undesired operation.

- This equipment has been tested and found to comply with the limits for a Class B digital device, pursuant to part 15 of the FCC rules. These limits are designed to provide reasonable protection against harmful interference in a residential installation. This equipment generates, uses and can radiate radio frequency energy and, if not installed and used in accordance with the instructions, may cause harmful interference to radio communications. However, there is no guarantee that interference will not occur in a particular installation. If this equipment does cause harmful interference to radio or television reception, which can be determined by turning the equipment off and on, the user is encouraged to try to correct the interference by one or more of the following measures:
  - Reorient or relocate the receiving antenna.
  - Increase the separation between the equipment and receiver.
  - Connect the equipment into an outlet on a circuit different from that to which the receiver is connected.
  - Consult the dealer or an experienced radio/TV technician for help.

NOTE: Changes or modifications not expressly approved by the manufacturer responsible for compliance could void the user's authority to operate the equipment.



Protect the environment by not disposing of this product or any batteries with household waste. This symbol indicates that this product shall not be treated as household waste. Check your local authority for recycling advice and facilities.





×



The Ultimate BATMOBILE™ Experience



©2022 Mattel. ® and ™ designate U.S. trademarks of Mattel, except as noted.

Mattel, Inc., 636 Girard Avenue, East Aurora, NY 14052, U.S.A. Consumer Services 1-800-524-8697. Mattel U.K. Limited, The Porter Building, 1 Brunel Way, Slough SL1 1FQ, UK. Mattel Australia Pty. Ltd., 658 Church St., Richmond, Victoria, 3121. Consumer Advisory Service - 1300 135 312. Mattel South Africa (PTY) LTD, Office 102 I3, 30 Melrose Boulevard, Johannesburg 2196. Mattel East Asia Ltd., Room 503-09, North Tower, World Finance Centre, Harbour City, Tsimshatsui, HK, China. Tel.: (852) 3185-6500. Diimport & Diedarkan Oleh: Mattel Continental Asia Sdn Bhd. Level 19, Tower 3, Avenue 7, No. 8 Jalan Kerinchi, Bangsar South, 59200 Kuala Lumpur, Malaysia.



THE BATMAN and all related characters and elements © & ™ DC Comics and Warner Bros. Entertainment Inc.  
WB SHIELD: © & ™ WBEI. (s22)

**HOTWHEELS.COM**



HCD18-0970\_DOM