

Standard Common part for master

Capacitor (1st priority)

No.	Part Value	Qty for update SCH
1	10PF chip 50v +/-20% SMD 0603	
2	20nF chip 50v +/-20% SMD 0603	
3	25nF chip 50v +/-20% SMD 0603	
4	1000nF chip 50v +/-20% SMD 0603	
5	0.1uF chip 50V +/-20% Y5V, 50V SMD0603	
6	0.1uF 25V +/-20% Y5V, PKG: Ceramic dia 6mm x 3.5	
7	0.033uF 25V Y5V, PKG: dia 4mm x 3.5	
8	10uF 25V +/-20% AL EL PKG: 5x11mm	
9	47uF 25V +/-20% AL EL PKG: 5x11mm	
10	100uF 25V +/-20% AL EL PKG: 5x11mm	
11	220uF 25V +/-20% AL EL PKG: 5x11mm	

Resistor:

No.	Part Value	Qty for update SCH
1	10 ohm +/-5% 0603	
2	100 ohm +/-5% 0603	
3	1K ohm +/-5% 0603	
4	4.7Kohm +/-5% 0603	
5	10k ohm +/-5% 0603	
6	47k ohm +/-5% 0603	
7	100kohm +/-5% 0603	
8	220k ohm +/-5% 0603	
9	1M ohm +/-5% 0603	
10	2.2M ohm +/-5% 0603	

Diode:

No.	Part Value	Qty for update SCH
1	IN4001PKG: DO-41 50V	
2	IN4148 PKG: DO-35 50V	

Transistor

No.	Part Value	Qty for update SCH
1	S8050NPN (1.5A) ISOT-23 V: 40; W: 0.3;	
2	S8550D PNP(1.5A) ISOT-23 V: 40; W: 0.3;	
3	S9014D NPN (1.5A) ISOT-23 V: 40; W: 0.3;	
4	B772 PNP A: 3; V: 40; Max. W: 1.25; PKG: TO-126;	
5	D882 NPN A: 3; V: 40; Max. W: 1.25; PKG: TO-126;	

Inductor

No.	Part Value	Qty for update SCH
1	Choke Coil DESC: 5.6uH 10% 1/2W	

PTC

No.	Part Value	Qty for update SCH
1	MF-R400-0-99	

Diode:

No.	Part Value	Qty for update SCH
1	IN5817: DO-41 50V	

Non Standard parts Guide Line (2nd priority)
Using E3 value for resistor, capacitor and inductor

Non Standard parts Guide Line (3rd priority)
Using E6 value for resistor, capacitor and inductor

TEST MODE:	REMARKS:	IC information:	History:

MATTEL MAPS All rights reserved

Size: A3	Project Number: BGK77	Project Name: FLYING RACER (CONTROLLER)	Revision: B
Date: 4/23/2014	MAPS Engineer: CHIN	Sheet: 1 of 1	DrawnBy: DuXuanHong
File: BGK77_TX SCHEMATIC B.SchDoc			

2.4GHz Module circuit

2413-2475MHz

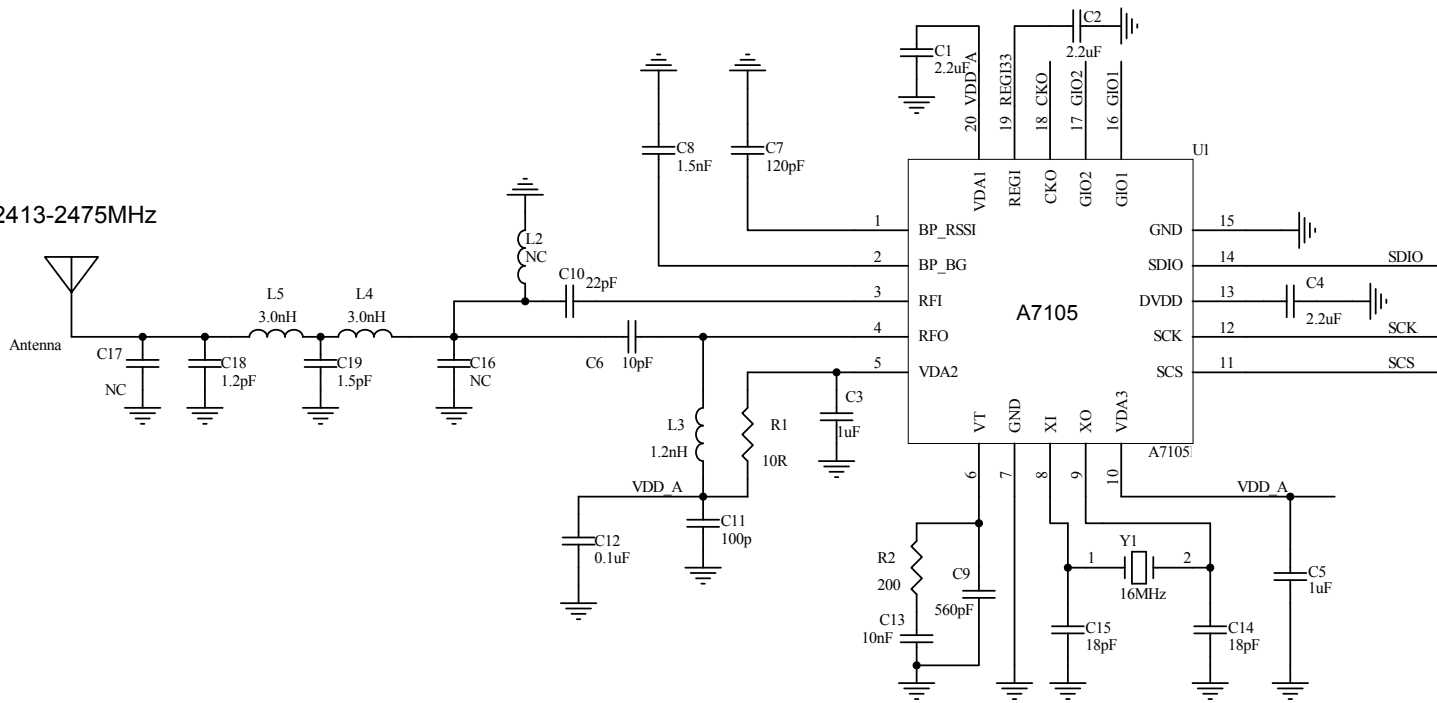

Title			TNT-7105 S		
Size	Number	Revision			
A4					
Date:	10-Apr-2014	Sheet of			
File:	D:\项目文件\A7105\remote central plane\11111111\A7105(0110)SCH.DDB				