



---

**UGD-D00181 Rev G**

**Air4G-W24  
Installation Guide**

**System Release 9.5**

---





---

## Copyright

© Copyright by **Airspan Networks Inc.**, 2010. All rights reserved worldwide.

The information contained within this document is proprietary and is subject to all relevant copyright, patent and other laws protecting intellectual property, as well as any specific agreements protecting Airspan Networks Inc. rights in the aforesaid information. Neither this document nor the information contained herein may be published, reproduced or disclosed to third parties, in whole or in part, without the express, prior, written permission of Airspan Networks Inc. In addition, any use of this document or the information contained herein for the purposes other than those for which it is disclosed is strictly forbidden.

Airspan Networks Inc. reserves the right, without prior notice or liability, to make changes in equipment design or specifications.

Information supplied by Airspan Networks Inc. is believed to be accurate and reliable. However, no responsibility is assumed by Airspan Networks Inc. for the use thereof nor for the rights of third parties which may be effected in any way by the use of thereof.

Any representation(s) in this document concerning performance of Airspan Networks Inc. product(s) are for informational purposes only and are not warranties of future performance, either expressed or implied. Airspan Networks Inc. standard limited warranty, stated in its sales contract or order confirmation form, is the only warranty offered by Airspan Networks Inc. in relation thereto.

This document may contain flaws, omissions or typesetting errors; no warranty is granted nor liability assumed in relation thereto unless specifically undertaken in Airspan Networks Inc. sales contract or order confirmation. Information contained herein is periodically updated and changes will be incorporated into subsequent editions. If you have encountered an error, please notify Airspan Networks Inc. All specifications are subject to change without prior notice.

Product performance figures quoted within this document are indicative and for information purposes only.



---

## Table of Contents

Copyright .....	2
Table of Contents .....	3
Summary of Figures .....	5
Summary of Tables .....	7
Warnings and Cautions .....	8
Human Exposure to Radio Frequencies .....	8
Radio Interference .....	8
Avoiding Radio Interference .....	8
Modifications .....	8
General .....	8
Safety .....	8
Warning Symbols .....	9
Service Information .....	9
UL Information .....	9
Lightning Protection .....	10
DECLARATION OF CONFORMITY .....	11
FCC Notice .....	12
Federal Communication Commission Notice .....	12
GPS Compliance .....	12
Maximum Output TX Power .....	13
Power Consumption .....	13
Antenna Types .....	13
Air4G-W24 Antenna Usage .....	14
1 About this Guide .....	17
1.1 Purpose .....	17
1.2 Intended Audience .....	17
1.3 Conventions .....	17
1.4 Referenced Documentation .....	17
1.5 Organization of this Guide .....	17
2 Introduction .....	19
2.1 Air4G-W24 .....	19
2.2 Air4G-W24 Frequency Ranges .....	19
2.2.1 Architecture .....	20
3 Getting Started .....	24
3.1 Workflow of Installation .....	24
3.2 Air4G-W24 Installation Checklist .....	25
4 Verify Prerequisites .....	26



## Air4G-W24 Installation Guide



---

4.1	Verify Safety Requirements .....	26
4.1.1	Warning of Hazardous Voltages .....	26
4.2	Verify Installation Requirements .....	27
4.2.1	Verify the Tools .....	27
4.2.2	Verify the Parts and Kits .....	27
4.2.3	Verify Components .....	33
5	Install Air4G-W24.....	36
5.1	Pole mount configuration .....	36
5.2	Wall mount configuration .....	39
5.2.1	Mounting Examples .....	41
5.3	Air4G-W24 Connections .....	42
5.4	Install Air4G-W24 Antennas .....	42
5.4.1	Install Dual Slant Antenna .....	43
5.4.2	Install Quad Slant Antenna .....	44
5.4.3	Antenna Mounting Clamps for Dual and Quad Slant Antennae .....	44
5.5	Optional Mounting Antenna on Air4G-W24 .....	46
5.5.1	Variable Tilt Antenna .....	46
5.6	Antenna Connection .....	47
5.7	GPS Antenna Assembly .....	48
5.8	Install Junction Box (Optional).....	49
5.8.1	Junction Box Installation .....	50
6	Connect and Manage Cables .....	52
6.1	Assemble Ethernet Connector.....	52
7	Set Power System .....	53
7.1	Power Input - DC .....	53
8	Appendix A .....	54
8.1	Review <i>Job Sheet</i> .....	54
8.2	Securing Fiber-optic Cable .....	54
8.3	Connecting the Fiber-optic Cable .....	56
9	Appendix C – Glossary of Terms.....	58
10	Appendix D – Installation Checklist .....	60
11	Appendix E .....	61
11.1	Revision History .....	61
11.2	Contact Information .....	61

---

## Summary of Figures

Figure 1 – Air4G-W24 – fiber or copper network interface.....	21
Figure 2 – Air4G-W24 – fiber network interface.....	21
Figure 3 - Air4G-W24 – each sector connected separately .....	22
Figure 4 – Air4G-W24 Functional Components .....	23
Figure 5 – Workflow of Installation .....	24
Figure 6 - PS – Air4G-W24.....	30
Figure 7 – Air4G-W24 Base Station Unit, Ethernet termination .....	33
Figure 8 – Air4G-W24 Base Station Unit, RF ports.....	34
Figure 9 – Air4G-W24 Cable Assembly for GPS Antenna .....	35
Figure 10 - Lightning/Surge protector (required) .....	35
Figure 11 - Junction box with pole assembly .....	35
Figure 12 – Pole Mounted Air4G-W24 Assembly.....	36
Figure 13 - pole mounting bracket (2 required) .....	36
Figure 14 - pole bracket wrap.....	37
Figure 15 - position brackets on pole .....	37
Figure 16 - spacing the brackets .....	37
Figure 17 – Pole Mounted Air4G-W24 .....	38
Figure 18 – Wall Mounted Air4G-W24.....	39
Figure 19 – Wall Mounted Air4G-W24 Wall Plate Details .....	40
Figure 20 - Wall mount .....	41
Figure 21 - GPS alternative assembly.....	41
Figure 22 - Air4G-W24 connections (bottom).....	42
Figure 23 – Air4G-W24 External Antenna Configuration .....	42
Figure 24 - Air4G-W24 Antenna Dual Slant Mast Mount Configuration.....	43
Figure 25 – Air4G-W24 Antenna Quad Slant Mast Mount Configuration.....	44
Figure 26 - Adjustable Mounting Kit, with Snaplock Stainless Steel Bands.....	45
Figure 27 - Adjustable Mounting Kit, with 'V' Blocks .....	46
Figure 28 - Variable tilt antenna .....	47
Figure 29 - Antenna mounted on Air4G-W24.....	47
Figure 30 - GPS cable assembly prior to mounting.....	48
Figure 31 - Attach GPS antenna to RG58 cable .....	48
Figure 32 - GPS antenna assembled on bracket .....	49
Figure 33 - Junction box with mounting brackets assembled .....	49
Figure 34 - mounting bracket (2 required).....	50
Figure 35 - Air4G-W24 assembly with optional junction box.....	51
Figure 36 – Ethernet connector cable termination .....	52
Figure 37 – Ethernet environmental connector assembly.....	52



## Air4G-W24 Installation Guide



---

Figure 38 – DC Power connection.....	53
Figure 39 - Secure fiber-optic cable, place tie.....	55
Figure 40 – Secure fiber-optic cable, pull tie .....	55
Figure 41 – Secure fiber-optic cable, snug tie.....	55
Figure 42 – Secure fiber-optic cable, cut excess tie.....	55
Figure 43 – Secure fiber-optic cable, use excess tie.....	56
Figure 44 – Secure fiber-optic cable, re-use excess tie .....	56
Figure 45 - fiber-optic connector with dust cover .....	56
Figure 46 – dust cover removed.....	56
Figure 47 - Fiber-Optic Outdoor Connector Plug (multimode) .....	57
Figure 48 - screw hand-tight.....	57
Figure 49 - Fiber-optic cable connected.....	57



---

## Summary of Tables

Table 1 - Air4G-W24 FCC Maximum Output TX Power.....	13
Table 2 - Air4G-W24 ETSI Maximum Output TX Power .....	13
Table 3 - Power Consumption .....	13
Table 4 - 700 MHz Antenna Types -Technical .....	13
Table 5 - 2.x GHz Antenna Types - Technical .....	14
Table 6 - 3.x GHz Antenna Types - Technical .....	14
Table 7 - Antenna arrays .....	15
Table 8 - Air4G-W24 frequency ranges.....	19
Table 9 - Air4G-W24 installation tools .....	27
Table 10 - Air4G-W24 installation parts and kits .....	27
Table 11 - Input Power for Air4G-W24 .....	29
Table 12 - Air4G-W24 wall mount installation parts .....	31
Table 13 - Air4G-W24 pole mount installation parts.....	31
Table 14 - Air4G-W24 additional parts and kits.....	31
Table 15 - Junction box (optional) .....	32
Table 16 - Air4G-W24 3.x physical dimensions .....	34
Table 17 - Air4G-W24 2.x & 0707 physical dimensions .....	34
Table 18 - Antenna connection.....	48
Table 19 - Cable hole sizes .....	50
Table 20 - Checklist for Procedure .....	60

---

## Warnings and Cautions

### Human Exposure to Radio Frequencies

The Air4G-W24 (formally MacroMAXe) antennas should be installed and operated from a minimum distance of 2.4 meters (for 3.x & 0707) or 3.2 meters (for 2.x) from your body.

### Radio Interference

This Air4G-W24 generates, uses, and can radiate radio frequency energy and, if not installed and used in accordance with the instructions, may cause harmful interference to radio communications. However, there is no guarantee that interference will not occur in a particular installation. If this equipment does cause harmful interference to radio or television reception, which can be determined by turning the equipment on and off, the technician is encouraged to try to correct the interference by performing one or more of the following measures:

- Re-orientate or relocate the antenna
- Increase separation between the BSs and/or End Device
- Connect the equipment to an outlet on a circuit different from that to which the power source is connected

### Avoiding Radio Interference

- The Air4G-W24 must not be co-located or operating in conjunction with any antenna or other transmitter.
- Ensure a minimum of 1-meter separation between co-located antennas of Air4G-W24 units.

### Modifications

Any changes and modifications to this device that are not expressly approved by Airspan Networks may void the user's authority to operate the equipment.

### General

- Only qualified personnel should be allowed to install, replace, and service the equipment.
- The device cannot be sold retail, to the general public or by mail order. It must be sold to operators.
- Installation must be controlled.
- Installation must be performed by licensed professionals.
- Installation requires special training. The Air4G-W24 radio and antenna should be installed ONLY by experienced installation professionals who are familiar with local building and safety codes and, wherever applicable, are licensed by the appropriate government regulatory authorities. Failure to do so may void Airspan's WiMAX product warranty and may expose the end user or the service provider to legal and financial liabilities. Airspan and its resellers or distributors are not liable for injury, damage or violation of regulations associated with the installation of outdoor units or antennas.

### Safety

1. Read this User Manual and follow all operating and safety instructions.
2. Keep all product information for future reference.
3. This product is supplied with a grounding power plug. Do not defeat this important safety feature.



4. **Warning:** High voltages exist inside the product - do not remove the lid or base: No user serviceable parts inside.
5. Position the power cord to avoid possible damage; do not overload wall outlets.
6. Do not place this product on or near a direct heat source, and avoid placing objects on the terminal.
7. Do not operate this device near water or in a wet location.
8. Use only a damp cloth for cleaning. Do not use liquid or aerosol cleaners. Disconnect the power before cleaning.
9. The units should not be located near power lines or other electrical power circuits.
10. The radio transceiver must be properly grounded to protect against power surges and accumulated static electricity. It is the user's responsibility to install this device in accordance with the local electrical codes.
11. Installation of the Air4G-W24 must be contracted to a professional installer.
12. Disconnect Device. The socket outlet should be easily accessible in case you have to disconnect the device.
13. When installed in the final configuration, the product must comply with the applicable Safety Standards and regulatory requirements of the country in which it is installed. If necessary, consult with the appropriate regulatory agencies and inspection authorities to ensure compliance.

### Warning Symbols

The following symbols may be encountered during installation or troubleshooting. These warning symbols mean danger. Bodily injury may result if you are not aware of the safety hazards involved in working with electrical equipment and radio transmitters. Familiarize yourself with standard safety practices before continuing.



Electro-Magnetic Radiation



High Voltage

### Service Information

Refer all repairs to qualified service personnel. Do not remove the covers or modify any part of this device, as this will void the warranty.

Disconnect the power to this product and return it for service if the following conditions apply:

- a. The terminal does not function after following the operating instructions outlined in this manual.
- b. Liquid has been spilled, a foreign object is inside, or the terminal has been exposed to rain.
- c. The product has been dropped or the housing is damaged.

Locate the serial number of the terminal, antenna, and transceiver and record these on your registration card for future reference. Use the space below to affix serial number stickers. Also record the MAC address, located on the back of the terminal.

### UL Information

- The equipment must be properly grounded according with NEC and other local safety code requirements.
- Reminder to all the BWA system installers: Attention to Section 820-40 of the NEC which provides guidelines for proper grounding and, in particular, specifies that the cable ground shall

---

be connected to the grounding system of the building, as close to the point of cable entry as is practical.

### Lightning Protection

**WARNING:** The following notes are general recommendations for the system. The wireless equipment should be installed by a qualified professional installer and must follow local and national codes for electrical grounding and safety. Failure to meet safety requirements and/or use of non-standard practices and procedures could result in personal injury and damage to equipment. A direct lightning strike may cause serious damage even if these guidelines are followed.

All outdoor wireless equipment is susceptible to lightning damage from a direct hit or induced current from a near strike. Lightning protection and grounding practices in local and national electrical codes serve to minimize equipment damage, service outages, and serious injury. Reasons for lightning damage are summarized as:

- Poorly grounded tower/antenna sites that can conduct high lightning strike energy into equipment.
- Lack of properly installed lightning protection equipment that can cause equipment failures from lightning induced currents.

A lightning protection system provides a means by which the energy may enter earth without passing through and damaging parts of a structure. A lightning protection system does not prevent lightning from striking; it provides a means for controlling it and preventing damage by providing a low resistance path for the discharge of energy to travel safely to ground. Improperly grounded connections are also a source of noise that can cause sensitive equipment to malfunction.

A good tower grounding system disperses most of the surge energy from a tower strike away from the building and equipment.

To limit the equipment damage due to a lightning strike, the following practices are recommended for the wireless system:

- Provide direct grounding from the antenna mounting bracket, the radio and antenna and the lightning arrestors to the same ground point at the base of the tower or a ground bus on the building. Use the grounding screws on the antenna bracket and the radio and antenna for terminating the ground wires.
- The AC wall outlet ground must be connected to the same grounding system as the BS.

---

## DECLARATION OF CONFORMITY

European Community, Switzerland, Norway, Iceland, and Liechtenstein

Declaration of Conformity with Regard to the R&TTE Directive 1999/5/EC

**English:**

This equipment is in compliance with the essential requirements and other relevant provisions of Directive 1999/5/EC.

**Deutsch:**

Dieses Gerät entspricht den grundlegenden Anforderungen und den weiteren entsprechenden Vorgaben der Richtlinie 1999/5/EU.

**Dansk:**

Denne udstyr er i overensstemmelse med de væsentlige krav og andre relevante bestemmelser i Direktiv 1999/5/EF.

**Español:**

Este equipo cumple con los requisitos esenciales así como con otras disposiciones de la Directiva 1999/5/EC.

**Greek:**

ΜΕ ΤΗΝ ΠΑΡΟΥΣΑ Airspan ΔΗΛΩΝΕΙ ΟΤΙ Ο ΕΞΟΠΛΙΣΜΟΣ ΣΥΜΜΟΡΦΩΝΕΤΑΙ ΠΡΟΣ ΤΙΣ ΟΥΣΙΩΔΕΙΣ ΑΠΑΙΤΗΣΕΙΣ ΚΑΙ ΤΙΣ ΛΟΙΠΕΣ ΣΧΕΤΙΚΕΣ ΔΙΑΤΑΞΕΙΣ ΤΗΣ ΟΔΗΓΙΑΣ 1999/5/ΕΚ.

**Français:**

Cet appareil est conforme aux exigences essentielles et aux autres dispositions pertinentes de la Directive 1999/5/EC.

**Íslenska:**

Þessi búnaður samrýmist lögboðnum kröfum og öðrum ákvæðum tilskipunar 1999/5/ESB.

**Italiano:**

Questo apparato é conforme ai requisiti essenziali ed agli altri principi sanciti dalla Direttiva 1999/5/EC.

**Nederlands:**

Deze apparatuur voldoet aan de belangrijkste eisen en andere voorzieningen van richtlijn 1999/5/EC.

**Norsk:**

Denne utstyret er i samsvar med de grunnleggende krav og andre relevante bestemmelser i EU-direktiv 1999/5/EC.

**Português:**

Este equipamento satisfaz os requisitos essenciais e outras provisões da Directiva 1999/5/EC.

**Suomalainen:**

Tämä laite täyttää direktiivin 1999/5/EY oleelliset vaatimukset ja on siinä asetettujen muidenkin ehtojen mukainen.

**Svenska:**

Denna utrustning är i överensstämmelse med de väsentliga kraven och andra relevanta bestämmelser i Direktiv 1999/5/EC.

**Român:**

Acest echipament este în conformitate cu cerințele esențiale și alte prevederi relevante ale Directivei 1999/5/CE.

The Declaration of Conformity related to this product can be obtained from [product\\_management@Airspan.com](mailto:product_management@Airspan.com)

---

## FCC Notice

### Federal Communication Commission Notice

This equipment has been tested and found to comply with the limits for a Class A digital device, pursuant to part 15 of the FCC Rules. These limits are designed to provide reasonable protection against harmful interference when the equipment is operated in a commercial environment. This equipment generates, uses, and can radiate radio frequency energy and, if not installed and used in accordance with the instruction manual, may cause harmful interference to radio communications. Operation of this equipment in a residential area is likely to cause harmful interference in which case the user will be required to correct the interference at his/her own expense.

Fixed and base stations transmitting a signal with an emission bandwidth greater than 1 MHz must not exceed an ERP of 1000 watts/MHz and an antenna height of 305 m HAAT, except that antenna heights greater than 305 m HAAT are permitted if power levels are reduced below 1000 watts/MHz ERP.

### GPS Compliance

The GPS is in compliance with the essential requirements and other relevant provisions of Directive 1999/5/EC."

The GPS complies with the following EMC Common Regulatory Testing standards:

- EN55022: Radiated and Conducted Emissions
- CISPR 22: Class B
- EN 50081-1: Generic Emissions Class B
- EN 50082-1: Generic Immunity Class B
- EN 61000-4-2: Electrostatic Discharge Immunity
- EN 61000-4-3: Radiated RF EM Field Immunity Test
- EN 61000-4-4: Electrical Fast Transient/Burst Test
- EN 61000-4-6: Conducted Immunity
- EN 61000-4-8: Magnetic Field Immunity



**Note:** A GPS is required for synchronizing between TDD sectors.



**Note:** A GPS Lightning/Surge protector is required. (ordered separately)

---

## Maximum Output TX Power

**Table 1 - Air4G-W24 FCC Maximum Output TX Power**

Frequency Band	FCC		Rest of the World		Antenna Gain
	TX	EIRP	TX	EIRP	
700 MHz	41.6 dBm	55.1 dBm	41.6 dBm	55.1 dBm	13.5 dBi
2.56 GHz	43.28 dBm	61.28 dBm	43 dBm	61 dBm	18 dBi
2.62 GHz	43.42 dBm	61.42 dBm	43 dBm	61 dBm	18 dBi
3.65 GHz	36.88 dBm	38.88 dBm	37 dBm	39 dBm	2 dBi

**Table 2 - Air4G-W24 ETSI Maximum Output TX Power**

Frequency Band	ETSI		Rest of the World		Antenna Gain
	TX	EIRP	TX	EIRP	
698-746 MHz	41.6 dBm	55.1 dBm	41.6 dBm	55.1 dBm	13.5 dBi
2290-2350 MHz	43 dBm	55.5 dBm	43 dBm	55.5 dBm	12.5 dBi
2340-2400 MHz	43 dBm	53 dBm	43 dBm	53 dBm	10.0 dBi
2496-2570 MHz	43 dBm	61 dBm	43 dBm	61 dBm	18.0 dBi
2560-2630 MHz	43 dBm	61 dBm	43 dBm	61 dBm	18.0 dBi
2620-2690 MHz	43 dBm	61 dBm	43 dBm	61 dBm	18.0 dBi
3300-3400 MHz	40 dBm	58 dBm	40 dBm	58 dBm	18.0 dBi
3400-3500 MHz	40 dBm	58 dBm	40 dBm	58 dBm	18.0 dBi
3500-3600 MHz	40 dBm	58 dBm	40 dBm	58 dBm	18.0 dBi
3600-3700 MHz	40 dBm	58 dBm	40 dBm	58 dBm	18.0 dBi
3650-3675 MHz	40 dBm	42 dBm	40 dBm	42 dBm	2 dBi
3700-3800 MHz	40 dBm	58 dBm	40 dBm	58 dBm	18.0 dBi



**Caution:** Do not set maximum output TX power to higher than local regulations.

## Power Consumption

**Table 3 - Power Consumption**

Air4G-W24	Watts
3.x	230 Max
2.x	370 Max
0707	370 Max

## Antenna Types

**Table 4 - 700 MHz Antenna Types -Technical**

Type	Frequency range	Gain	Part number
------	-----------------	------	-------------

60° 13.5 dBi Dual X-Polar – mounting kit (50 > 115 mm) included	698 - 806 MHz	13.5 dBi	SEC60Q-700-13.5-1
90° 12.5 dBi Dual X-Polar – mounting kit (50 > 115 mm) included	698 - 806 MHz	12.5 dBi	SEC90Q-700-12.5-1
OMNI Directional	698-746 MHz	6 dBi	MT-221024/NV
OMNI Directional	746-806 MHz	6.5 dBi	MT-221023/NV

**Table 5 - 2.x GHz Antenna Types - Technical**

Type	Frequency range	Gain	Part number
65° Quad X-Polar – mounting kit (50 > 115 mm) included	2.3-2.7 GHz	18.0 dBi	SEC60Q-2.X-RC-1
90° Quad X-Polar – mounting kit (50 > 115 mm) included	2.3-2.7 GHz	17.0 dBi	SEC90Q-2.X-RC-1
60° Dual Slant X-Polar – mounting kit (50 > 115 mm) included	2.3-2.7 GHz	18.0 dBi	SEC60X-2.X-RC-1
90° Dual Slant X-Polar – mounting kit (50 > 115 mm) included	2.3-2.7 GHz	17.0 dBi	SEC90X-2.X-RC-1
Omni 10dBi Vertical External	2.3-2.49 GHz	10 dBi	ANT2300OV10-360

**Table 6 - 3.x GHz Antenna Types - Technical**

Type	Frequency range	Gain	Part number
60° Quad X-Polar – mounting kit (50 > 115 mm) included	3.3 - 3.8 GHz	18.0 dBi	SEC60Q-3.5-RC-1
90° Quad X-Pola – mounting kit (50 > 115 mm) included	3.3 - 3.8 GHz	17.0 dBi	SEC90Q-3.5-RC-1
60° Dual Slant X-Polar – mounting kit (50 > 115 mm) included	3.3 - 3.8 GHz	18.0 dBi	SEC60X-3.5-RC-1
90° Dual Slant X-Polar – mounting kit (50 > 115 mm) included	3.3-3.8 GHz	17.0 dBi	SEC90X-3.5-RC-1
Omni Reg Compl Vertical Sector	3.3 – 3.5 GHz	10.0 dBi	OMNIV-3.4-RC-2

### Air4G-W24 Antenna Usage

Air4G-W24 has four (4) RF ports that can be connected to either:

- A single four-port antenna
- Two two-port antennas
- Four single-port antennas



**Note:** Appropriate mounting kit (included) for the dual and quad port antennas are required.

- Quad port cross polarized (X-Pol) antenna with four (4) ports – connected via 4 RF jumper cables to Air4G-W24.

- Dual slant cross polarized (X-Pol) antenna with two (2) ports - connected via 2 RF jumper cables to Air4G-W24.
- Omni antennas – for 360 degree coverage using a single Air4G-W24 - requires an Omni antenna for each receiver – 2 or 4 Omni antennas.



**Note:** The Omni antennas must be separated – with at least one meter separation from each other (in 2.X and in 3.X GHz)

- Fixed tilt dual/quad port antennas (where the tilt is set by the way the mounting kit is installed).



**Note:** Required mounting kits for fixed tilt dual/quad port antennas are included.

- Manual Electric Tilt (MET) dual/quad antennas - a variable tilt antenna available for mounting directly on the Air4G-W24 with no need for physical tilting of the antenna.

The following table describes different antenna arrays when using either two (2) receivers or four (4) receivers:

**Table 7 - Antenna arrays**

Frequency Band	# of Receivers	Sector	Antenna Type	# of Antennas
700 MHz	2	60°	698 - 806 MHz 60° 13.5 dBi Dual X-Polar	1
700 MHz	4	60°	698 - 806 MHz 60° 13.5 dBi Dual X-Polar	2
2.3 GHz	2	65°	2.3-2.7 GHz 60° Dual Slant X-Polar	1
2.3 GHz	4	65°	2.3-2.7 GHz 60° Quad X-Polar	1
2.5 GHz	2	65°	2.3-2.7 GHz 60° Dual Slant X-Polar Antenna	1
2.5 GHz	4	65°	2.3-2.7 GHz 60° Quad X-Polar	1
3.3-3.8 GHz	2	65°	3.3-3.8 GHz 60° Dual Slant X-Polar	1
3.3-3.8 GHz	4	65°	3.3-3.8 GHz 60° Quad X-Polar	1
700 MHz	2	90°	698 - 806 MHz 90° 12.5 dBi Dual X-Polar	1
700 MHz	4	90°	698 - 806 MHz 90° 12.5 dBi Dual X-Polar	2
2.3 GHz	2	90°	2.3-2.7 GHz 90° Dual Slant X-Polar	1
2.3 GHz	4	90°	2.3-2.7 GHz 90° Quad X-Polar	1
2.5 GHz	2	90°	2.3-2.7 GHz 90° Dual Slant X-Polar	1
2.5 GHz	4	90°	2.3-2.7 GHz 90° Quad X-Polar	1
3.3-3.8 GHz	2	90°	3.3-3.8 GHz 90° Dual Slant X-Polar	1



## Air4G-W24 Installation Guide



3.3-3.8 GHz	4	90°	3.3-3.8 GHz 90° Quad X-Polar	1
2.3 GHz	2	360°	2.3-2.49 GHz Omni 10 dBi Vertical External Antenna	2
2.3 GHz	4	360°	2.3-2.49 GHz Omni 10 dBi Vertical External Antenna	4
2.5 GHz	2	360°	Generic Omni	2
2.5 GHz	4	360°	Generic Omni	4
3.3-3.4 GHz	2	360°	3.3-3.5 GHz Omni Reg Compl Vertical Sector	2
3.3-3.4 GHz	4	360°	3.3-3.5 GHz Omni Reg Compl Vertical Sector	4
3.4-3.6 GHz	2	360°	3.4-3.6 GHz Omni Reg Compl Vertical Sector	2
3.4-3.6 GHz	4	360°	3.4-3.6 GHz Omni Reg Compl Vertical Sector	4
3.6-3.8 GHz	2	360°	3.6-3.8 GHz Omni Reg Compl Vertical Sector	2
3.6-3.8 GHz	4	360°	3.6-3.8 GHz Omni Reg Compl Vertical Sector	4



## 1 About this Guide

This section discusses the purpose, intended audience, conventions, referenced documentation and organization for this guide.

### 1.1 Purpose

This guide provides the workflow and step-by-step procedures for Installing the Air4G-W24 (formally MacroMAXe). These procedures include:





- Verify Prerequisites
- Install the Air4G-W24
- Connect and Manage Cables
- Set Power System

### 1.2 Intended Audience

This guide is intended for persons who are responsible for Installing the Air4G-W24. These persons should have a working knowledge of the WiMAX system.

### 1.3 Conventions

This document uses the following informational conventions.

Icon	Description
	<b>Checkpoint:</b> Marks a point in the workflow where there may be an exit or branch to some other procedure. At each <b>Checkpoint</b> the reason for an exit or branch is given along with specific directions to locate the entry point in the other procedure.
	<b>Reference:</b> Gives a resource in the workflow that may be needed to complete a procedure along with specific directions to use the resource.
	<b>Caution:</b> Describes a possible risk and how to lessen or avoid the risk.
	<b>Advice:</b> Provides a recommendation based on best practice.
	<b>Note:</b> Provides useful information.

### 1.4 Referenced Documentation

- Air4G-W24 Product Description

### 1.5 Organization of this Guide

This guide is organized into the following Sections:

- About this Guide
- Introduction
- Get Started
- Verify Prerequisites



## Air4G-W24 Installation Guide



- 
- Install the Air4G-W24
  - Connect and Manage Cables
  - Set Power System
  - Appendixes [Review Job Sheet, Securing & Connecting the Fiber-Optic cable, Glossary of Terms, Installation Checklist, Contact information and Revision history]

## 2 Introduction

This section provides a descriptive overview of the Air4G-W24 (formally MacroMAXe) (3.x, 2.x and 0707) and its place in the product suite.

### 2.1 Air4G-W24

Air4G-W24 is a highly integrated macro-cell base station with all-in-one packaging of RF and baseband components. Air4G-W24 includes integrated quad RF transceivers to support four channel diversity and MIMO. It is available as an all outdoor solution for Mobile WiMAX applications to minimize physical footprint and operator OPEX.

Air4G-W24 fully supports the interoperable R6 reference point for interworking with ASN Gateways. Air4G-W24 also has a “Stand Alone” mode for fixed/nomadic applications which do not require seamless handover. When Air4G-W24 is used in “Stand Alone” mode there is no need for an ASN Gateway. Air4G-W24 supports IP CS and Ethernet CS. It even supports a hybrid mode where both IP CS and Ethernet CS (including VLAN support) are supported. Air4G-W24 implements dual 40dBm (10W) transmitters in 2.x GHz, dual 38 dBm (6.3W) in 700 MHz and dual 37dBm (5W) transmitters in 3.x GHz band.

Air4G-W24 is an outdoor radio that is mounted outside on a pole or wall. Air4G-W24 is available in numerous frequency bands and in numerous channels see: [Air4G-W24 Frequency Ranges](#). Air4G-W24 is managed by an SNMP-based network management system (Netspan) using standard and proprietary MIBs. Basic management can be performed using any standard Web browser.



**Note:** For management refer to Air4G-W24 Commissioning documentation.

### 2.2 Air4G-W24 Frequency Ranges

The table below lists the frequency range of Air4G-W24 variants currently available. This table will grow as more variants become available.

**Table 8 - Air4G-W24 frequency ranges**

Band	Variant	Lower Frequency	Upper Frequency	Channel Bandwidth	Duplex
700 MHz	0707	698 MHz	746 MHz	<ul style="list-style-type: none"> <li>➤ 3.5MHz</li> <li>➤ 5MHz</li> <li>➤ 7MHz</li> <li>➤ 10MHz</li> </ul>	TDD
2.3 GHz	2310 Lo	2290 MHz	2350 MHz	<ul style="list-style-type: none"> <li>➤ 3.5MHz</li> <li>➤ 5MHz</li> <li>➤ 7MHz</li> <li>➤ 10MHz</li> </ul>	TDD
	2310 Hi	2340 MHz	2400 MHz		
2.5 GHz	2510 Lo	2496 MHz	2570 MHz	<ul style="list-style-type: none"> <li>➤ 3.5MHz</li> <li>➤ 5MHz</li> <li>➤ 7MHz</li> <li>➤ 10MHz</li> </ul>	TDD
	2510 Mid	2560 MHz	2630 MHz		
	2510 Hi	2620 MHz	2690 MHz		

Band	Variant	Lower Frequency	Upper Frequency	Channel Bandwidth	Duplex
3.x GHZ	3305	3300 MHz	3400 MHz	<ul style="list-style-type: none"> <li>➤ 3.5MHz</li> <li>➤ 5MHz</li> <li>➤ 7MHz</li> <li>➤ 10MHz</li> </ul>	TDD
	3405	3400 MHz	3500 MHz	<ul style="list-style-type: none"> <li>➤ 3.5MHz</li> <li>➤ 5MHz</li> <li>➤ 7MHz</li> <li>➤ 10MHz</li> </ul>	TDD
	3505	3500 MHz	3600 MHz	<ul style="list-style-type: none"> <li>➤ 3.5MHz</li> <li>➤ 5MHz</li> <li>➤ 7MHz</li> <li>➤ 10MHz</li> </ul>	TDD
	3605	3600 MHz	3700 MHz	<ul style="list-style-type: none"> <li>➤ 3.5MHz</li> <li>➤ 5MHz</li> <li>➤ 7MHz</li> <li>➤ 10MHz</li> </ul>	TDD
	3705	3700 MHz	3800 MHz	<ul style="list-style-type: none"> <li>➤ 3.5MHz</li> <li>➤ 5MHz</li> <li>➤ 7MHz</li> <li>➤ 10MHz</li> </ul>	TDD

### 2.2.1 Architecture

A highly flexible and scalable WiMAX Base Station, the Air4G-W24 is capable of supporting Mobile WiMAX profiles across multiple frequency bands.



**Note:** The following is for illustration only; actual layout may differ as infrastructure is installation-specific.



**Note:** Air4G-W24 must be properly grounded according with NEC and other local safety code requirements.



**Note:** Installation of the GPS Lightning/Surge protector (ordered separately) is necessary to protect the GPS antenna.

Two options for cascading three (3) sectors are illustrated below:

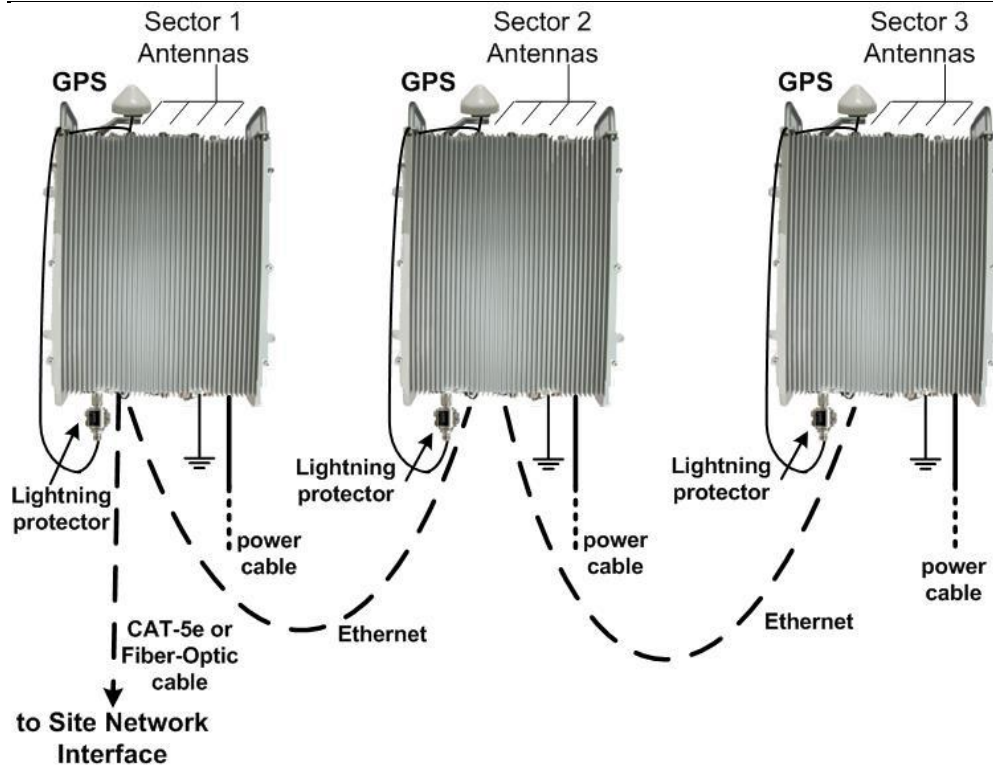

**Figure 1 – Air4G-W24 – fiber or copper network interface**

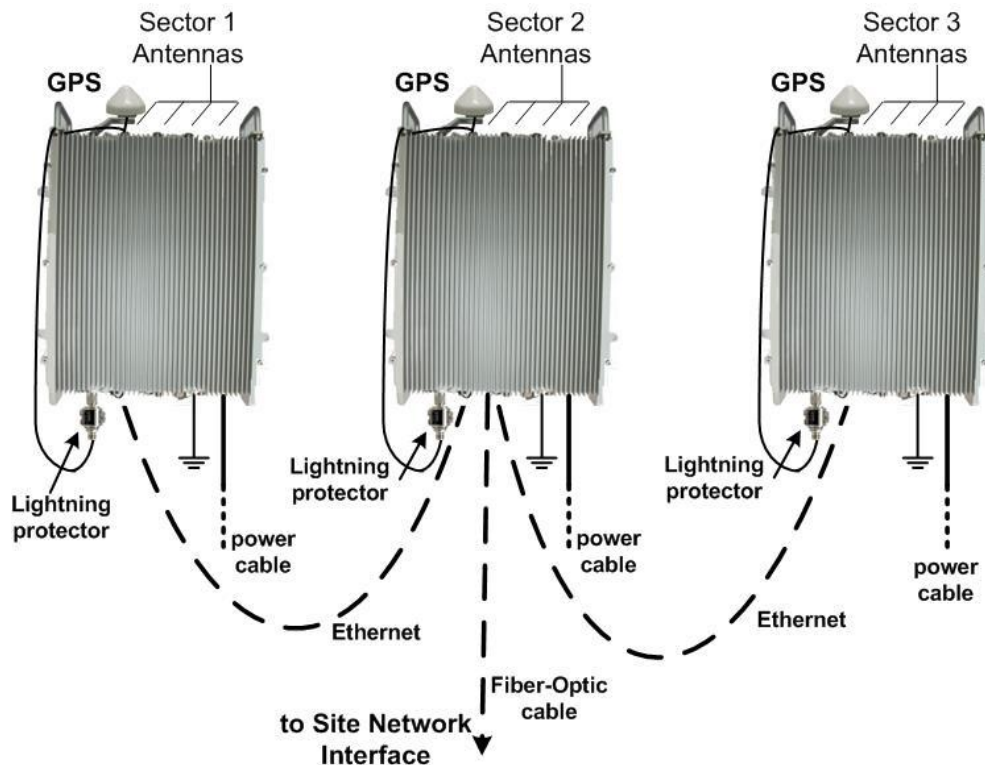

**Figure 2 – Air4G-W24 – fiber network interface**

An alternative architecture, where each sector is connected separately to the backhaul/backbone solution, therefore avoiding a single point of failure, as shown below:

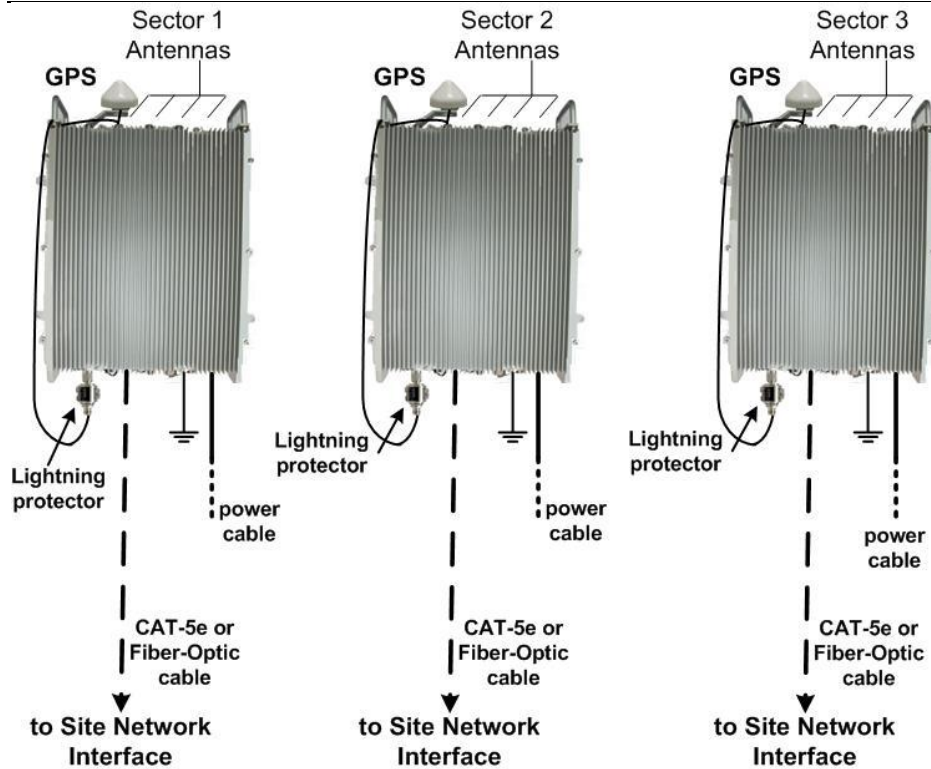

Figure 3 - Air4G-W24 – each sector connected separately

- Note:** Air4G-W24 can also be connected via a LAN Switch for greater Failsafe protection.
- Note:** When the Fiber-Optic cable connection is employed the Ethernet cable connection (Eth 1) is disabled.
- Note:** Auto-negotiation must always be enabled on the core network side.
- Note:** Illustration above displays the GPS connected directly to the top of the units there is also a remote GPS antennae option.

The Air4G-W24 is a fully integrated all outdoor base station sector that contains all RF, Baseband, GPS Synchronization and 3-sector aggregation functionality. In one box it comprises the following functional elements:

- Quad Receiver / Dual Transmitter
- SDR Card
- Ethernet Switch
- GPS

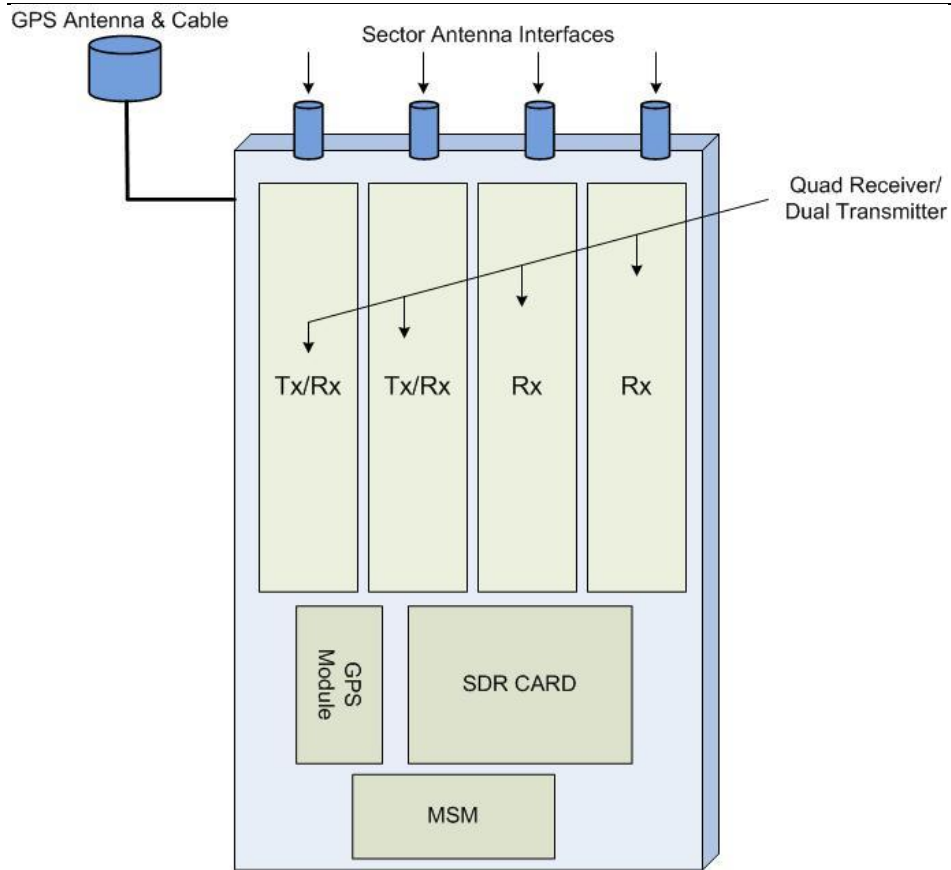

Figure 4 – Air4G-W24 Functional Components

### 3 Getting Started

#### 3.1 Workflow of Installation

The Workflow to install the Air4G-W24 is shown in the following diagram:

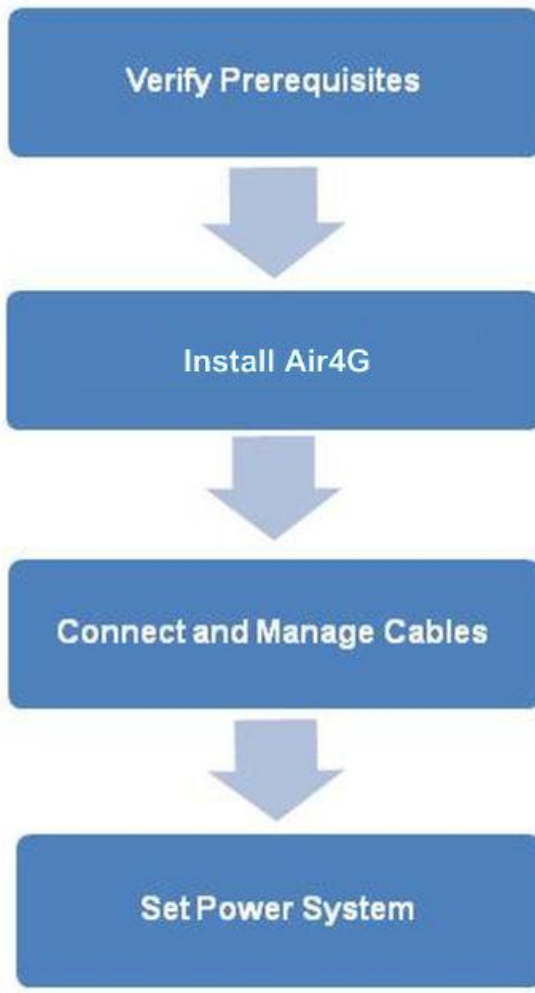

Figure 5 – Workflow of Installation



**Caution:** Antennas 1 & 2 Tx/Rx must be connected and attached before Air4G-W24 is powered on.





---

### 3.2 Air4G-W24 Installation Checklist

Plan the installation of the Air4G-W24 by using the Installation Checklist, which you can find as a removable job aid in [Appendix A](#) for this guide.

---

## 4 Verify Prerequisites

Prior to installing the Air4G-W24, verify the required safety, power, tools, parts and components.



---

**Reference:** Set up requirements for the installation is detailed in the *Job Sheet*, see [Appendix A](#) for this guide.

---

### 4.1 Verify Safety Requirements

Read and follow all warning notices and instructions marked on the product or included in this manual.

When installed in the final configuration, the product must comply with the applicable Safety Standards and regulatory requirements of the country in which it is installed. If necessary, consult with the appropriate regulatory agencies and inspection authorities to ensure compliance.

Ascertain the radiation hazards when working in an environment close to other antennas and Electromagnetic fields, e.g. working on towers with other microwave transmitters etc. and act accordingly.

#### 4.1.1 Warning of Hazardous Voltages

On AC installations, hazardous voltages exist. Use caution when verifying or working with AC power. Remove metal jewelry that could come into contact with AC power.

On DC sections, short circuiting the low voltage, low impedance circuits can cause severe arcing that may result in burns or eye damage. Remove rings, watches etc. to avoid shorting DC circuits.



---

**Note:** Airspan products do not contain hazardous substances (as defined in UK Control of Substances Hazardous to Health Regulations 1989 and the Dangerous Substances Regulations 1990). At the end of any Airspan products life cycle, the customer should consult with Airspan to ensure that the product is disposed of in conformance with the relevant regulatory requirements.

---



---

**Caution:** Any modifications to this device not expressly authorized by the manufacturer could void the user's authority to operate this device.

---

## 4.2 Verify Installation Requirements

### 4.2.1 Verify the Tools



**Table 9 - Air4G-W24 installation tools**

Tool
Large Crosshead Screw driver Phillips # 3 or Pozidrive # 3
Small flat blade screwdriver
Medium flat blade screwdriver
13mm or 1/2 inch open ended spanner
10mm or 13/32 inch open ended spanner
Wire strippers
Wire cutters
Ring terminals crimp tool
RJ45 crimp tool

### 4.2.2 Verify the Parts and Kits

**Table 10 - Air4G-W24 installation parts and kits**

Air4G-W24 Base Station parts	Consisting of
1 x Air4G-W24 unit	Base station unit
3 x RJ45 Weatherproof Connector Covers	Weatherproof connector covers for use with standard cat 5 RJ45 network connections.
1 x mains cable 14AWG x2 (ordered separately)	30 meter lead with M17 3 pole plug
When distance from outdoor Power supply to Base Station is <b>over</b> 30 meters additional power cable must be connected via a junction box (ordered separately) for total distance of up to 130 meters.	
	14AWG x2 (ordered separately) – up to 40 meters
	12AWG x6 (ordered separately) – up to 100 meters
1 x Ethernet RJ45 environmental shroud	LTW IP68 or Amphenol environmental connector

Air4G-W24 Base Station parts	Consisting of
1 x Sunshield fixing kit (optional) (ordered separately) including quad antenna adaptor brackets (x 2).	M8 x 20 Hex Cap screws - 12 M8 plain washers - 12 M8 spring washers – 12 M8 Hex nuts - 4 M12 x 20 screws – 4 M12 nuts – 4 M12 flat washers – 4 M12 spring washers - 4
 <b>Note:</b> The Sunshield brackets are only applicable for antennas that utilize Mechanical Electric Tilt (MET). i.e. – Argus-SSPX310F.	
 <b>Warning:</b> A Sunshield is mandatory for temperatures of above 45°.	
1 x Air4G-W24 installation mount kit (ordered separately)	M8 x 20 Hex Cap screws – 8 M8 Hex nuts - 4 M8 plain washers – 8 M8 spring washers - 8
Pole Mount Bracket Assembly: Dia. 120-170 mm – top & bottom – plus fixing accessories.  Dia. 170-230 mm – top & bottom – plus fixing accessories. (ordered separately)	Accessories included
Pole Mount Bracket Assembly: Dia. 60-120 mm – top & bottom – plus fixing accessories. (ordered separately)	Accessories included
1 x earth kit	1 x M5 screws 1 x M5 washers 1 x M5 spring washers Alternative: SEMS screw (includes 2 washers)

Air4G-W24 Base Station parts	Consisting of
GPS antenna & accessories (each ordered separately)	<p>1x GPS Antenna. An active GPS antenna which, by using the appropriate mounting bracket, can be used with Air4G-W24 for network synchronization.</p> <p>For mounting directly to the top of Air4G-W24, this GPS Antenna should be used in conjunction with Air4G-W24 GPS Antenna mounting bracket w/Handle pre-assembled on the Air4G-W24 and the 80cm GPS Cable RG58 TNC-TNC.</p> <p>When mounting remotely from the base station unit, this antenna should be used in conjunction with the Remote GPS Antenna Mounting Bracket (GPS-MNT-1) and the 16m GPS Cable RG58 TNC-TNC.</p> <p>80cm or 16m Cable Assembly - 80cm (CBL-GPS-TNC-0.8-1) or 16m (CBL-GPS-TNC-16-1) RG58 cable. 16m connects remote mounted GPS Antenna (GPS-ANT-1) to the Air4G-W24 via TNC connectors. The 80cm, cable for mounting GPS directly to the top of Air4G-W24.</p>
GPS Lightning/Surge protector (ordered separately)	1x Lightning/Surge protector (required)
AC/DC Power Supply (PS)	Indoor power converter for 700 MHz
	Indoor power converter for 2.xGHz
	Outdoor power converter for 3.xGHz
Type-IC DC Power Cable	Available either in - 10, 15 or 30 meter lengths. Additional lengths available.
ODC Twin Fiber Cable (Multimode) (optional) (ordered separately)	<p>Available either in - 10, 15, 30, 50, 75 or 100 meter lengths.</p> <hr/> <div style="display: flex; align-items: center;">  <p><b>Note:</b> Maximum up to 500 meters as this is a multimode interface.</p> </div> <hr/>
Multimode fiber pigtail cable (not included) (optional) (ordered separately)	Multimode fiber pigtail cable – ODC - LC connector. Terminates the outdoor fiber cable and provides an indoor LC connector. 2 meter length.
Grounding Cable (required) (not included)	Circular earth braid, 120A current (16 mm <sup>2</sup> ), jacketed or not with cable size = AWG 4 – 6 with lug (terminal) on enclosure side with hole M6

The Air4G-W24 power supply (PS) can be installed with various cable lengths according to the site requirements. The cable lengths are determined by the length of the run between the PS and the Air4G-W24. Use the following table to determine the required power supply output to ensure proper operation of the Air4G-W24.

**Table 11 - Input Power for Air4G-W24**



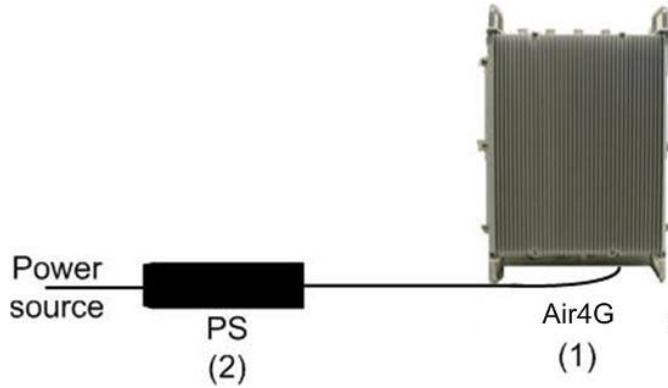

	Air4G-W24 2x10 (2.3-2.7 GHz) & Air4G-W24 0707 (698-746 MHz)	Air4G-W24 3x05 (3.3-3.38 GHz)
Input Voltage to Air4G-W24 (1)	-38 VDC to -60 VDC	-38 VDC to -60 VDC
PS output Voltage – 30 meter cable (2)	-42 VDC min	-41 VDC min

	Air4G-W24 2x10 (2.3-2.7 GHZ) & Air4G-W24 0707 (698-746 MHz)	Air4G-W24 3x05 (3.3-3.38 GHZ)
PS output Voltage – 75 meter cable (2)	-50 VDC min	-46 VDC min
PS output Voltage – 100 meter cable (2)	-53 VDC min	-49 VDC min







**Figure 6 - PS – Air4G-W24**

**Table 12 - Air4G-W24 wall mount installation parts**

Parts		Images
1	Wall Plate	
2	Top Hanger	
3	Lower Hanger	
4	GPS Antenna mounting bracket w/Handle (pre-assembled)	
5	Handle (pre-assembled)	





**Table 13 - Air4G-W24 pole mount installation parts**

Parts		Images
 <b>Note:</b> in addition to the Wall mounting kit.		
1	Top & Lower Pole Strap (x2) for 120 > 170 MM (short strap) Top & Lower Pole Strap (x2) for 170 > 230 MM (long strap) Top & Lower bracket (x2)	
 <b>Note:</b> in addition to the Wall mounting kit.		
2	Pole bracket for 60 > 120 MM	

**Table 14 - Air4G-W24 additional parts and kits**

Additional Common Accessories (not provided by Airspan)
Spare RJ45 connectors
Cable ties
Ring terminal for earth strap. M5 / M6
Earth strap cable (4-6 mm) (yellow and green cable)
Weatherproof / Outdoor mains cable splice kit or termination box.

**Table 15 - Junction box (optional)**

Optional Junction Box	Consisting of
1 x Junction box (ordered separately)	Junction box
1 x PG11 Weatherproof gland (connector), included with junction box	Weatherproof connector 
1 x PG16 Weatherproof gland (connector) , included with junction box	Weatherproof connector 
1 x PG29 Weatherproof gland (connector) , included with junction box	Weatherproof connector 
Additional power cable	14AWG x2 (ordered separately) – up to 40 meters
	12AWG x6 (ordered separately) – up to 100 meters
2x mounting bracket(s) for pole and wall mounting	Bracket (x2) 
2x pole bands (stainless steel), as required, supplied.	60 – 80 mm (2 ¼") 



Optional Junction Box	Consisting of
2x pole bands (stainless steel), as required, supplied.	80 – 100 mm (3 1/2") 
Mounting screws – for mounting brackets to junction box.	EJOT WN1412 – K50 x 12 – 4 supplied.
Wall mounting fasteners	Hole size = 7 mm (not supplied - customer responsibility)
Sufficient cable wires ties, as required	(not supplied - customer responsibility)

### 4.2.3 Verify Components

Air4G-W24 is shown below from the Ethernet termination and RF port end views respectively.



Figure 7 – Air4G-W24 Base Station Unit, Ethernet termination



Figure 8 – Air4G-W24 Base Station Unit, RF ports

4.2.3.1 Physical Dimensions

Air4G-W24 BS is in an all outdoor enclosure.

Table 16 - Air4G-W24 3.x physical dimensions

Parameter	Value	Comment
Height	410 mm (16.14 inches)	The physical dimensions exclude handles and connectors.
Width	350 mm (13.78 inches)	
Depth	155 mm (6.10 inches)	
Weight	Aprox. 17 kg (37.47 lbs.)	

Table 17 - Air4G-W24 2.x & 0707 physical dimensions

Parameter	Value	Comment
Height	410 mm (16.14 inches)	The physical dimensions exclude handles and connectors.
Width	350 mm (13.78 inches)	
Depth	170 mm (6.69 inches)	
Weight	Aprox. 17.6 kg (38.80 lbs.)	

RF Ports for antenna connections are N-Type Female connectors located on the top of the Air4G-W24 enclosure. Adjacent to these are SMA connectors used for RF monitoring purposes during installation / maintenance. For normal operation, these are covered with a weatherproof cap.

A 16m RG58 cable connects a remote mounted GPS antenna to the Air4G-W24 or 80cm cable for connection directly on the Air4G-W24 by way of TNC connectors. Alternatively, an 80cm, cable connects the GPS directly to the top of Air4G-W24. The cable assembly for the remote GPS antenna is shown below.



Figure 9 – Air4G-W24 Cable Assembly for GPS Antenna

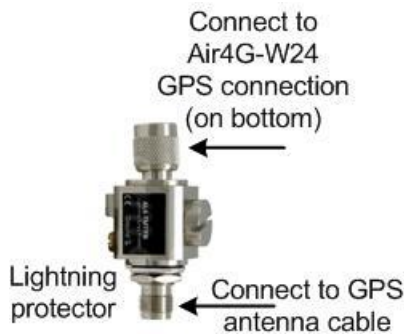

Figure 10 - Lightning/Surge protector (required)

#### 4.2.3.2 Junction Box (Optional)

The Junction box (optional) is an outdoor enclosure that measures 152 mm (6 in.) in height, 170 mm (6.70 in.) in width and 95 mm (3.74 in.) in depth. The unit is shown below with the pole mounting bands assembled. The Junction box is required when the distance from the outdoor Power supply to Base Station is **over** 30 meters for total distance of up to 130 meters.



**Note:** If – 48 volt DC can be verified and guaranteed the Junction box may not be required. Contact customer support to determine.

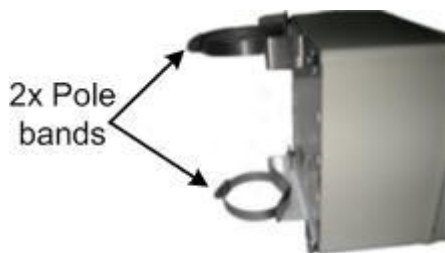

Figure 11 - Junction box with pole assembly

## 5 Install Air4G-W24

Install the Air4G-W24 base station by pole mount, wall mount, or single point. The Air4G-W24 can be deployed as a remote radio head (RRH) connected to a pair of single (usually vertically polarized) or single dual independently mounted antennas via standard RF coaxial cables. Antennas are positioned with up to 10 wavelengths horizontal separation to give optimal Downlink and Uplink MIMO performance.



**Caution:** Proper local rigging and hoisting practices should be followed when installing the Air4G-W24. The pre-assembled handles are **not** to be used for hanging, attaching or hoisting the unit into place.

### 5.1 Pole mount configuration

The following image shows the pole mount assembly.

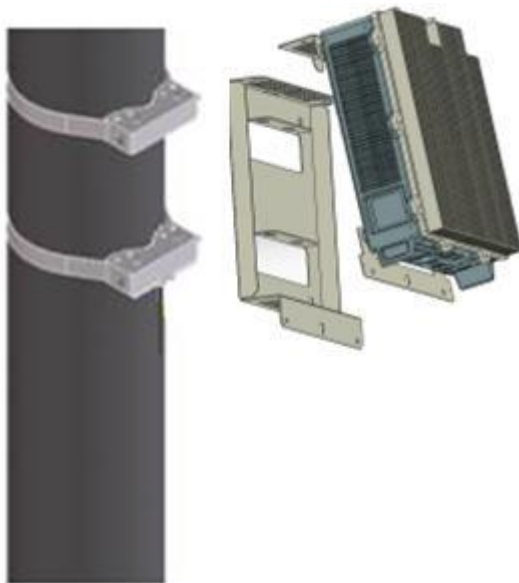

Figure 12 – Pole Mounted Air4G-W24 Assembly

To mount the Air4G-W24 in the pole mount configuration (for poles 170 > 230 mm), perform the following steps:



Figure 13 - pole mounting bracket (2 required)

1. Wrap the band to properly fit on the pole. Set the slot on the hook to insure a tight fit.

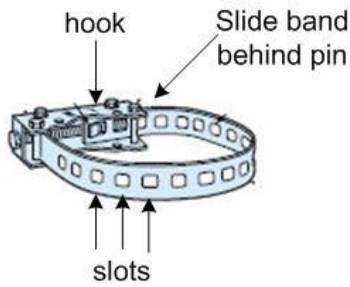

**Figure 14 - pole bracket wrap**

- Align and position each of the 2 pole clamp brackets at the heights required to attach the Air4G-W24 (with the threaded holes facing up). Adjust the upper bracket and tighten in place. Adjust the lower bracket and hand-tighten.

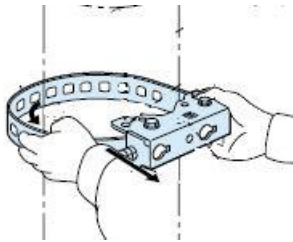

**Figure 15 - position brackets on pole**



**Note:** Remove assembled screws (2) and washers (4) for later use.

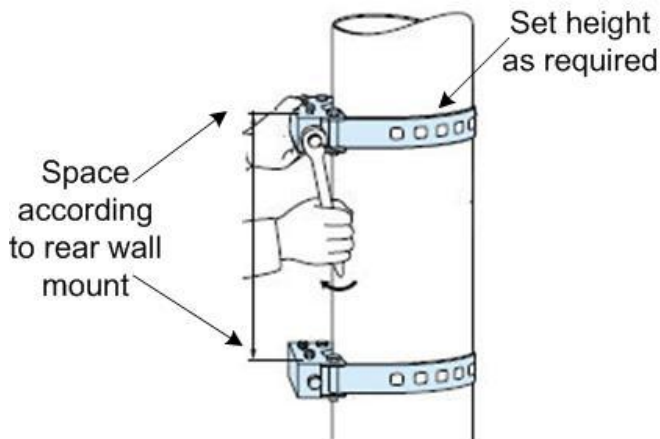

**Figure 16 - spacing the brackets**

- Lift the rear wall mount and place the screws through the head clearance holes and position the unit so that the top mounting holes retain the unit.



**Caution:** These units weigh over 17 kg take care when lifting.

- Screw the bottom two the M8 screws and washers into the two standoff fittings at the bottom bracket.
- Check and tighten all fixing screws.

**To mount the Air4G-W24 in the pole mount configuration (for poles 120 > 170 mm), perform the following steps:**



**Note:** Remove long (assembled) strap and replace with short strap (supplied).

1. Wrap the band to properly fit on the pole. Set the slot on the hook to insure a tight fit.
2. Align and position each of the 2 pole clamp brackets at the heights required to attach the Air4G-W24 (with the threaded holes facing up). Adjust the upper bracket and tighten in place. Adjust the lower bracket and hand-tighten.



**Note:** Remove assembled screws (2) and washers (4) for later use.

3. Lift the rear wall mount and place the screws through the head clearance holes and position the unit so that the top mounting holes retain the unit.



**Caution:** These units weigh over 17 kg., take care when lifting.

4. Screw the bottom two the M8 screws and washers into the two standoff fittings at the bottom of the Air4G-W24 enclosure.
5. Check and tighten all fixing screws.



Figure 17 – Pole Mounted Air4G-W24

To mount the Air4G-W24 in the pole mount configuration (for poles 60 > 120 mm), perform the following steps:

1. Attach the two (2) pole brackets (shown above in Table 6) to the pole (with the threaded holes facing up) at the heights required to attach the Air4G-W24.
2. Tighten upper pole bracket and hand tighten (loosely) the lower pole bracket for later adjustment.



**Caution:** These units weigh 17 kg – 17.6 kg, take care when lifting.

3. Lift and align the Air4G-W24 unit and place the screws through the head clearance holes and position the unit so that the top mounting holes retain the unit and loosely tighten all screws.
4. Tighten all fixing screws.

## 5.2 Wall mount configuration

The following image shows the wall mount assembly.

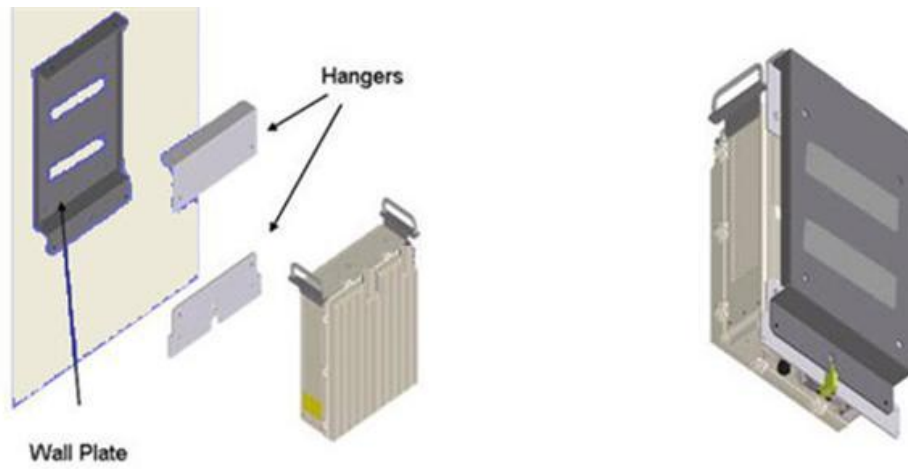

Figure 18 – Wall Mounted Air4G-W24

The following diagram depicts the Wall Plate Details.

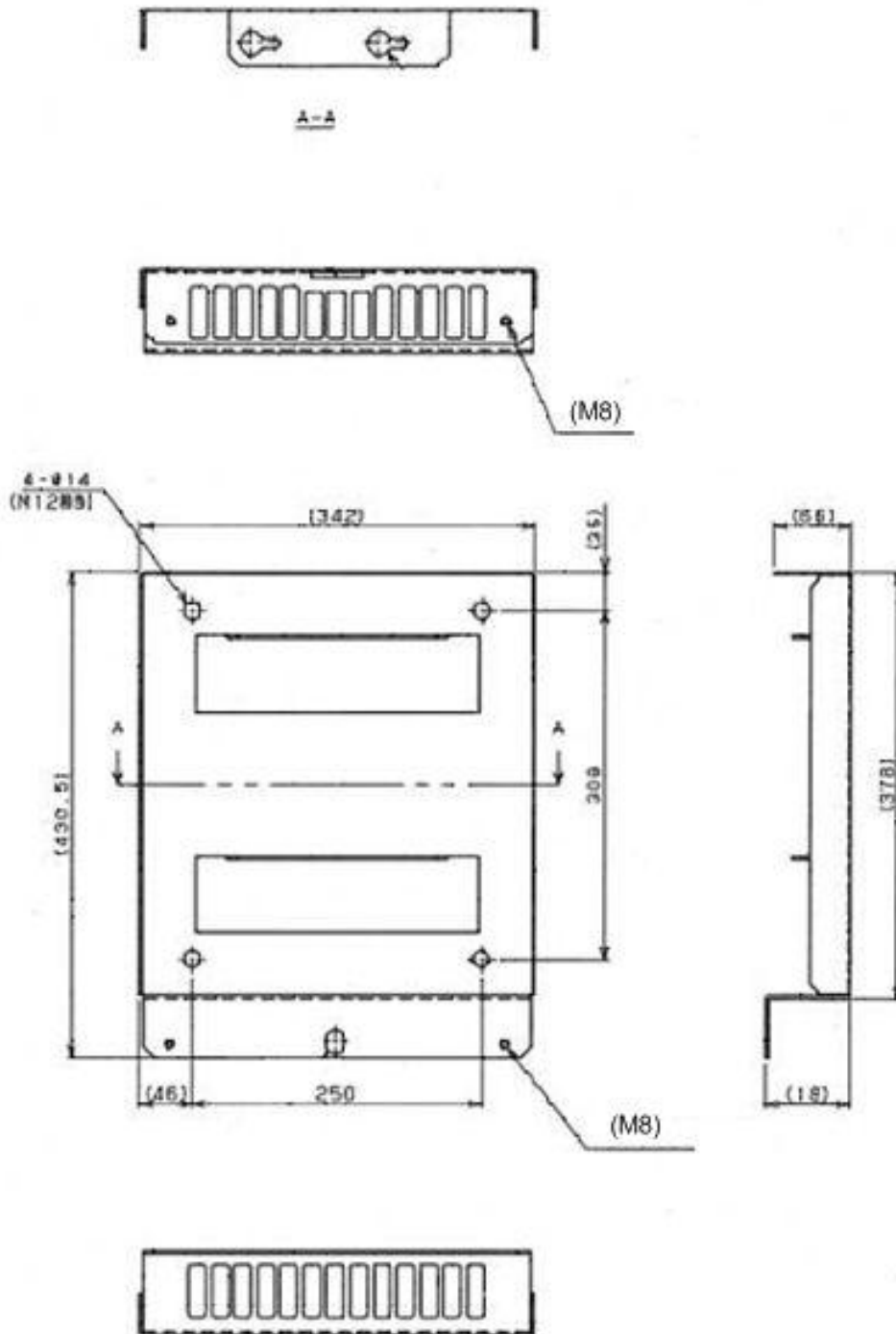

Figure 19 – Wall Mounted Air4G-W24 Wall Plate Details

To mount the Air4G-W24 in the wall mount configuration, perform the following steps:

1. Attach the Wall Plate to the wall at the height required to attach the Air4G-W24.
2. Fasten the Hangars to the rear side of the Air4G-W24 enclosure, position the niched Hangar so it is lower on the wall with the niche facing down.
3. Lift the enclosure and place the screws through the head clearance holes and position the unit so that the top mounting holes retain the unit.





**Caution:** This unit weighs 17 kg – 17.6 kg, take care when lifting.

4. Screw the bottom two screws and washers into the two standoff fittings at the bottom of the Air4G-W24 enclosure.
5. Tighten all fixing screws.

## 5.2.1 Mounting Examples

The following displays a typical wall mount.



**Figure 20 - Wall mount**



**Note:** The GPS bracket (pre-assembled) is on the (back) side closest to the wall so as not to interfere with the sunshield assembly.

The following displays a possible assembly alternative in the event of interference to the GPS by equipment already in place.



**Figure 21 - GPS alternative assembly**

### 5.3 Air4G-W24 Connections

The following diagram displays the connections on the bottom side of the Air4G-W24.

The base station requires a secure ground connection. The cable should also be grounded to the tower which is grounded at the tower base. A grounding screw fitted with a flat washer and lock washer is provided on the bottom of the chassis clearly marked with the universal ground symbol as shown below.

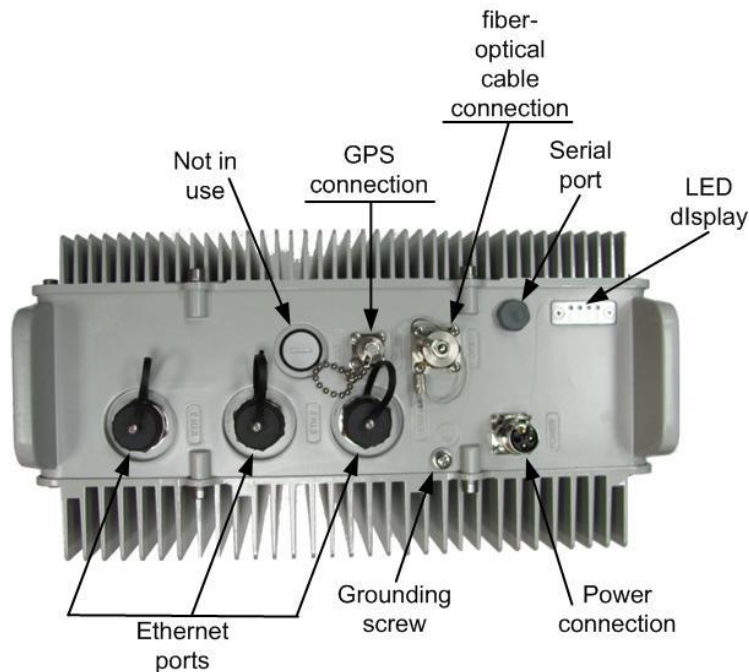

Figure 22 - Air4G-W24 connections (bottom)

### 5.4 Install Air4G-W24 Antennas

Use this procedure to install a linear dual slant antenna for the Air4G-W24 in the mast mount configuration.



Figure 23 – Air4G-W24 External Antenna Configuration



**Note:** Separate antenna distance according to RF planning.

---

### 5.4.1 Install Dual Slant Antenna



**Figure 24 - Air4G-W24 Antenna Dual Slant Mast Mount Configuration**



**Note:** Mounting kit (50 > 115 mm) is included.

---

**To mount the dual slant antenna for the Air4G-W24 in the mast mount configuration, perform the following steps:**

1. Attach the Antenna brackets to the top and bottom of the radome.
2. Attach the tilt arm to the top bracket of the radome.
3. Fasten the ends of the adjustable pipe mounts to the top and bottom brackets of the radome.
4. Lift the radome and place the screws through the adjustable pipe mounts and position the radome so that the top mounting holes retain the unit.
5. Screw the bottom two screws and washers into the two standoff fittings at the bottom of the radome assembly.
6. Tighten all fixing screws.
7. Attach, connect and secure antenna RF cable between the antenna and the appropriate Air4G-W24 Antenna RF connection on the top of the unit.

## 5.4.2 Install Quad Slant Antenna



Figure 25 – Air4G-W24 Antenna Quad Slant Mast Mount Configuration



**Note:** Mounting kit (50 > 115 mm) is included.

To mount the Quad slant antenna for the Air4G-W24 in the mast mount configuration, perform the following steps:

1. Attach the Antenna brackets to the top and bottom of the radome.
2. Attach to the top bracket of the radome.
3. Fasten the ends of the adjustable pipe mounts to the top and bottom brackets of the radome.
4. Lift the radome and place the screws through the adjustable pipe mounts and position the radome so that the top mounting holes retain the unit.
5. Screw the bottom two screws and washers into the two standoff fittings at the bottom of the radome assembly.
6. Tighten all fixing screws.
7. Attach, connect and secure antenna RF cable between the antenna and the appropriate Air4G-W24 Antenna RF connection on the top of the unit.

## 5.4.3 Antenna Mounting Clamps for Dual and Quad Slant Antennae

The following are some adjustable antenna mounting clamp options for both Dual and Quad Slant antenna scenarios.

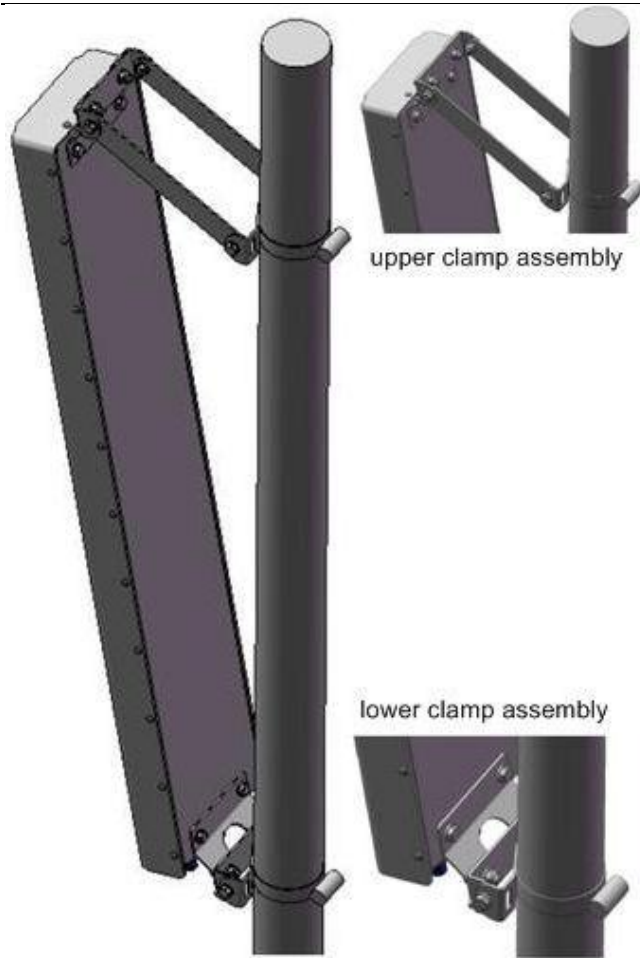

Figure 26 - Adjustable Mounting Kit, with Snaplock Stainless Steel Bands



Figure 27 - Adjustable Mounting Kit, with 'V' Blocks

## 5.5 Optional Mounting Antenna on Air4G-W24

Either Antenna shown can be mounted on the Air4G-W24 unit or mast mounted.



**Note:** The sunshield kit is required for this type of assembly. Contact your supplier to order.

### 5.5.1 Variable Tilt Antenna

There is a Variable Tilt Antenna available for mounting on the Air4G-W24. The antenna maybe connected directly to the Air4G-W24 with no need for physical tilting of the antenna. The Manual Electric Tilt (MET) antenna has a rotating nut that adjusts a threaded rod which moves in and out while displaying a tilt scale, as shown below.

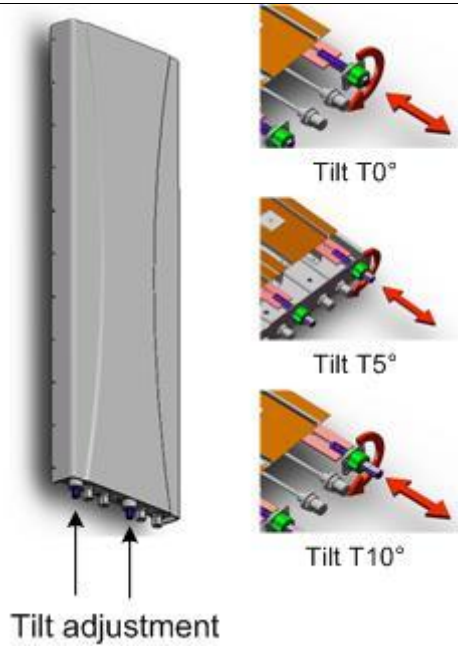

Figure 28 - Variable tilt antenna

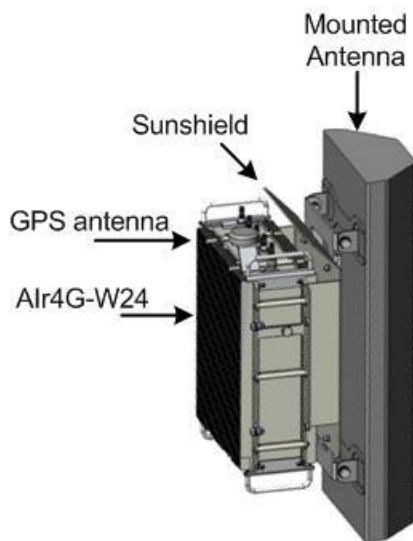

Figure 29 - Antenna mounted on Air4G-W24

## 5.6 Antenna Connection



**Caution:** Antennas 1 & 2 Tx/Rx must be connected and attached before Air4G-W24 is powered on.



**Caution:** Power down Air4G-W24 prior to disconnecting antenna.

The following describes the antenna connection:



**Note:** Some antennas are labeled 1, 2, 3, 4 and some are labeled '+', '-', '+', '-'.



**Caution:** 1 & 2 Tx/Rx must be '+' & '-' or '-' & '+' and the same for 3 & 4.

**Table 18 - Antenna connection**

Air4G-W24 port	Port Label	Antenna port
Tx/Rx	ANT 1	1 or '+'
Tx/Rx	ANT 2	2 or '-'
Rx	ANT 3	3 or '+'
Rx	ANT 4	4 or '-'

## 5.7 GPS Antenna Assembly

To mount the GPS antenna directly on the Air4G-W24:

1. Route the RG58 cable through the flat washer and the 2 nuts (supplied).
2. Position the RG58 cable below the mounting hole on the GPS antenna mounting bracket, as shown below:

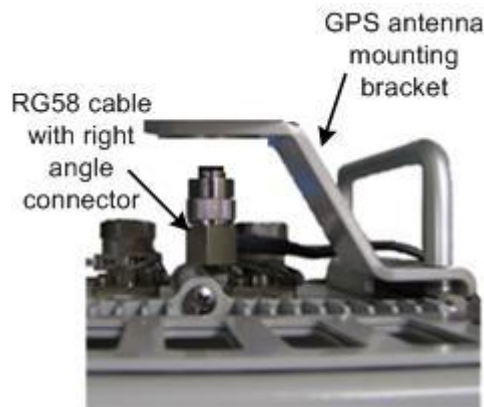

**Figure 30 - GPS cable assembly prior to mounting**

3. Hand-tighten the RG58 cable TNC (90°) connector to the mating connector on the GPS antenna.

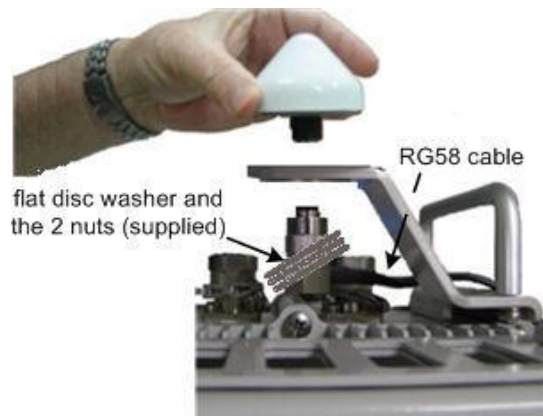

**Figure 31 - Attach GPS antenna to RG58 cable**



- Slide the flat washer up to the underside of the mounting bracket, then thread 1 nut onto the GPS antenna threaded base and tightened.
- The second nut is then secured and tightened against the first nut to create a clamp load against the first nut, as shown below:

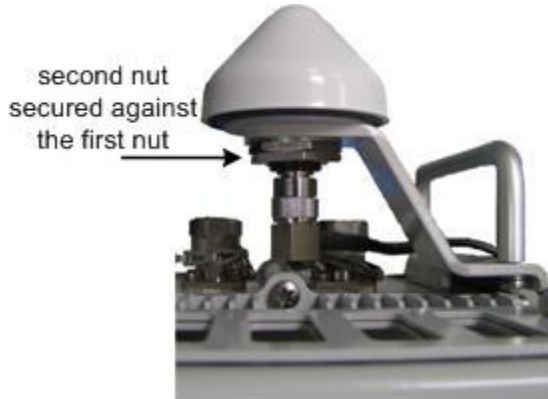

**Figure 32 - GPS antenna assembled on bracket**

- Connect the RG58 cable attached to the GPS Lightning/Surge protector (required) to the GPS connection on the bottom Air4G-W24.

### 5.8 Install Junction Box (Optional)



**Note:** Contact Airspan customer-service to determine whether junction box installation is required. Installation may be required, depending on the distance between the external power-supply and the BS, as well as the minimum voltage supplied by the power-supply.

The Junction box (optional) can be pole-mounted or wall-mounted.



**Warning:** Mount the junction box in an orientation such that the cable ports (located on the bottom) face downwards. This prevents rain water from settling on the ports, thereby, avoiding damage.

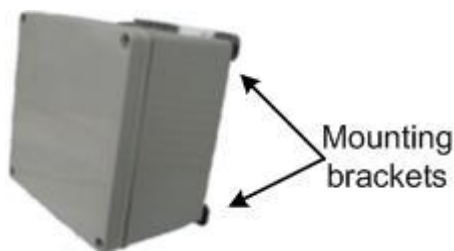

**Figure 33 - Junction box with mounting brackets assembled**

For either mounting method, the mounting bracket provides mounting holes (displayed below):

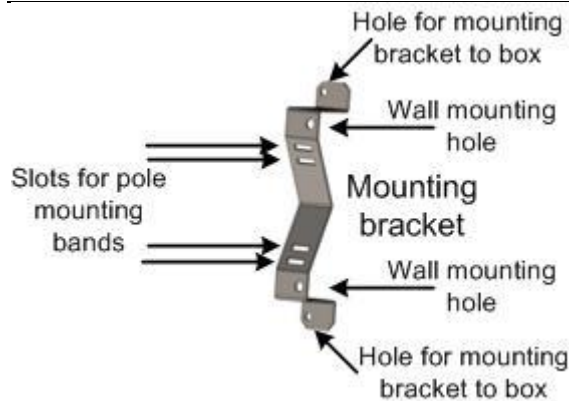

Figure 34 - mounting bracket (2 required)

### 5.8.1 Junction Box Installation

To install the junction box:

1. Prior to installation connect the 2 mounting brackets to the back of the junction box fastening to the provided holes. The wall mounting hole orientation should be towards the outer edges of the junction box.
2. Remove the junction box's cover, leaving the rubber gasket in place.
3. Prepare the cables for connection by performing the following:
  - a. Strip about 25.4 mm (1 inch) of the outer jacket of the cable to expose the wires.
  - b. Using a wire-stripping tool, expose about 6.3 mm (0.25 inch) of each of the wires by stripping the wires' insulation.
4. Determine which cable entry holes are to be used and remove the appropriate plug.

Table 19 - Cable hole sizes

Cable Entry hole determination
Gland hole PG11 (M18) for cable terminating at MicroMAXe
Gland hole PG29 (M36) for cable 12AWG x6
Gland hole PG16 (M22) for cable 14AWG x2



**Note:** Save the rubber grommets from the plugs to be used on the weatherproof glands (connectors).

5. Remove the nut on the weatherproof connector and slide the rubber grommet onto the threaded shaft.
6. Set the weatherproof connector into the hole and from inside the box, thread the included nut onto the shaft until tight.
7. Insert the exposed wires into the relevant screw-type terminal block (+ to + and - to -) and then secure them in place by tightening the screw of each terminal.
8. Fasten the Junction box onto the pole or wall as required within the required distance of the Air4G-W24 enclosure.
9. Perform the same procedure (steps 3-7) with the cable terminating in the in the Air4G-W24 enclosure.

10. Open the connector clamp collar and feed about 101.6 mm (4 inches) of cable from the Air4G-W24 through it and into the box. Tighten the collar around the cable, forcing the seal to compress around the cable.
11. Replace the cover by using the four (4) screws, ensuring the gasket (for weatherproofing) is firmly in place on the rim of the cover.



**Note:** It is important to provide strain relief and drip loop for the cables. Create a drip loop and strain relief using cable tie, to tie cable to pole, as displayed in the figure below:



**Figure 35 - Air4G-W24 assembly with optional junction box**

## 6 Connect and Manage Cables

The Ethernet cable is connected to the Air4G-W24 using a standard RJ45 connector protected by a harsh environment protective casing.

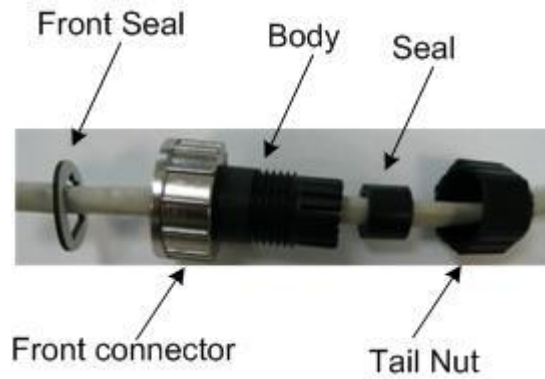

Figure 36 – Ethernet connector cable termination

### 6.1 Assemble Ethernet Connector

1. Pass the Cat 5 cable through the seal, front connector, body and tail nut of the environmental connector casing as shown above.
2. Paste the front seal on the collar of the connector body.
3. Terminate the Ethernet cable with an RJ45 connector plug.
4. Seat the RJ45 connector plug securely into the body cavity.
5. Tighten the tail nut on to the body forcing the seal to compress around the cable.



Figure 37 – Ethernet environmental connector assembly

## 7 Set Power System



**Hazardous voltage!** Before working, ensure that the power is removed from the power connection cables. When the system is powered on, **do not touch the power terminals.**

### 7.1 Power Input - DC

Each unit is provided with a 3/10/30 meter 48 volt power cable terminated with a female connector at one end and bare wires at the other.



**Caution:** It is important that the power connector is attached at the correct end or damage to the connector/equipment will result.



**Note:** Check Power Supply for proper polarization.

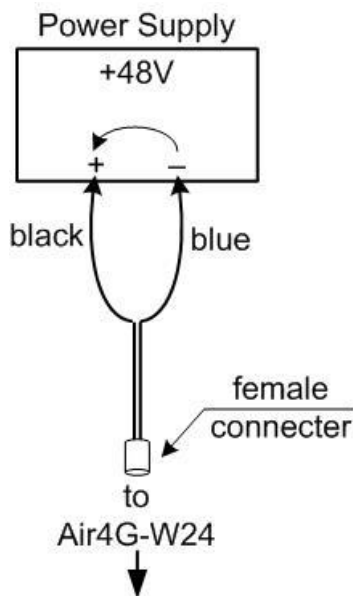

Figure 38 – DC Power connection

## 8 Appendix A

### 8.1 Review Job Sheet

The *Job Sheet* should include the following information:

- **BS location and identity.**
- Whether the system is required to be locked to a GPS timing reference.
- **A BSID is required for each BS TRx.** This should be in a format xxxxxx:xxxxxx where x is a decimal digit.
- Network configuration information for the BS TRx.
- **Traffic Port:** Not applicable.
- **IP Address:** Should only be set if Management IP Mode is set to Static IP Address. See below for Management IP Mode parameter.
- **Netmask:** Should only be set if Management IP Mode is set to Static IP Address. See below for Management IP Mode parameter.
- **Default Gateway:** Should only be set if Management IP Mode is set to Static IP Address. See below for Management IP Mode parameter.
- **Management VLAN:** Specified as either Untagged or Tagged
- **Management VLAN Tag:** Should only be set if Management VLAN is set to Tagged
- **Management IP Mode:** Specified as Static IP Address or Obtain IP Address via DHCP
- **Ethernet Mode:** Specified as Auto-negotiate or Fixed
- **Ethernet Rate:** Need only be configured if Ethernet Mode is set to Fixed, specified as 10M or 100M.
- **Ethernet Duplex:** Need only be configured if Ethernet Mode is set to Fixed, specified as Full or Half.
  - **SNMP configuration information.** This will allow events from the BS to arrive at the specified Netspan server. This will include the following information:
    - **Read Only Community:** This should be specified to the same value as in Netspan Discovery Parameters (found under Server on Netspan left hand panel).
    - **Read Write Community:** This should be specified to the same value as in Netspan Discovery Parameters (found under "Server" on Netspan left hand panel).
    - **SNMP Port Number:** This should be specified to the same value as in Netspan Discovery Parameters (found under "Server" on Netspan left hand panel).
    - **IP Address:** This specifies Netspan IP address (found under Server Global Configuration, which is under Server on Netspan left hand panel).
    - **Community:** Normally specified to the same value as for Read Only Community.
    - **Port Number:** Normally specified to a value of 9023.
      - **NTP configuration.** This specifies a list of NTP servers.

### 8.2 Securing Fiber-optic Cable

The Milli-Tie can be used to secure cables in the same manner as normally used for nylon straps. The steps below show the basic use of the product.



**Caution:** Over-tightening of cable ties may causes damage and degrade system performance.

**To secure fiber-optic cables, perform the following steps:**

1. Place the Millie-Tie around the target, and thread the tongue through the last large aperture in the rearmost cell.



**Figure 39 - Secure fiber-optic cable, place tie**

2. Pull or slide the Millie-Tie onto the target. Note that the Millie Tie stretches to cushion the installation.



**Figure 40 – Secure fiber-optic cable, pull tie**

3. Release the tension when snug, then cut and remove any excess strip. Always cut through the square sections, not the wider cells.



**Figure 41 – Secure fiber-optic cable, snug tie**



**Note:** Millie-Tie is efficient, and simply gets a little shorter after each use. The remaining strip can be kept and reused.



**Figure 42 – Secure fiber-optic cable, cut excess tie**

6. Repeat these steps for each use.



Figure 43 – Secure fiber-optic cable, use excess tie



Figure 44 – Secure fiber-optic cable, re-use excess tie

### 8.3 Connecting the Fiber-optic Cable

To secure fiber-optic cable to the Air4G-W24, perform the following steps:

1. Remove the dust cover from end of a panel connector:

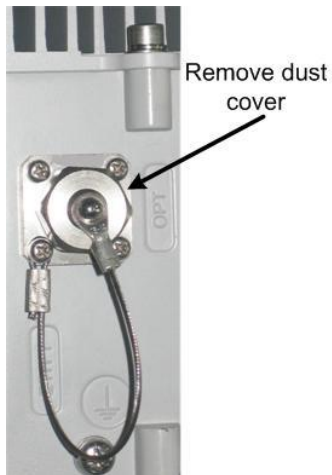

Figure 45 - fiber-optic connector with dust cover



Figure 46 – dust cover removed

7. Remove the protective cover from the fiber-optical cable.
8. Align the fiber-optical cable connector and line up the groove on the cable connector with the pin on the panel connector.
9. Screw the connector cover nut until hand-tight.





Figure 47 - Fiber-Optic Outdoor Connector Plug (multimode)



Figure 48 - screw hand-tight



Figure 49 - Fiber-optic cable connected

---

## 9 Appendix C – Glossary of Terms

AAA	Authentication, Authorization and Accounting
AAS	Advanced Antenna System
AF	Application Function
ARQ	Automatic Repeat reQuest
ASN	Access Service Network
ASN GW	ASN Gateway
ATCA	Advanced Telecommunications Computing Architecture
BS	Base Station
BWA	Broadband Wireless Access
CHAP	Challenge Handshake Authentication Protocol
CPE	Customer Premises Equipment
CQI	Channel Quality Indicator
CSN	Connectivity Service Network
DSM	Digital Surface Model
DTM	Digital Terrain Model
EAP	Extensible Authentication Protocol
FA	Foreign Agent
FBSS	Fast Base Station Switching
GUI	Graphical User Interface
HA	Home Agent
H-ARQ	Hybrid Automatic Repeat reQuest
HO	Handover/Handoff
IMS	IP Multimedia Subsystem
IP	Internet Protocol
IPsec	IP security
LR	Location Register
MAC	Media Access Control
MDH	Macro Diversity Handover
MIMO	Multiple Input Multiple Output
MIP	Mobile IP
MRC	Maximal Ratio Combining
MS	Mobile Station
NAP	Network Access Provider
NAS	Network Access Server
NLOS	Non Line of Sight
NSP	Network Service Provider
NWG	Network Working Group



## Air4G-W24 Installation Guide



---

OBSAI	Open Base Station Standard Initiative
OFDMA	Orthogonal Frequency Division Multiplexing (Multiple Access)
PA	Paging Agent
PAAA	Proxy AAA
PC	Paging Controller
PF	Policy Function
PHY	PHYsical Layer
PMIP	Proxy MIP
PPP	Point-to-Point Protocol
RADIUS	Remote Authentication Dial In User Service
RRA	Radio Resource Agent
RRC	Radio Resource Controller
RRM	Radio Resource Management
SAS	Smart Antenna System
SDR	Software Defined Radio
SFA	Service Flow Authorization
SFM	Service Flow Management
SIM	Subscriber Identity Module
SIP	Session Initiation Protocol
SOFDMA	Scalable Orthogonal Frequency Division Multiplexing (Multiple Access)
STC	Space Time Coding
TDD	Time Division Duplex
VoIP	Voice over IP
X.509	ITU-T standard for PKI digital certificates

## 10 Appendix D – Installation Checklist

The Checklist below gives the high-level steps in the Workflow for this procedure. Detach or print this page to use as a job-aid for completing the actions this procedure requires.

**Table 20 - Checklist for Procedure**

Procedure	Actions	Outcome
1. Verify Prerequisites	Verify safety requirements Verify installation requirements	All requirements are in place for a successful commissioning of Air4G-W24.
2. Install Air4G-W24	Pole mount configuration Wall mount configuration Install Air4G-W24 antennas	
3. Connect and manage cables	Assemble Ethernet connector <i>or</i> Disassemble Ethernet connector, <i>then</i> Assemble LTW Ethernet connector	
4. Set power system	Power input Power output	

## 11 Appendix E

### 11.1 Revision History

Revision	Originator	Date	Description
Draft 1	D. Cann	2-2009	Initial document
Draft B	M. Falik	3-2009	Additional content & template changes
Rev A	M. Falik	10-2009	Additional content
Rev B	M. Falik	10-2009	Corrected Graphics + Additional content
Rev C	M. Falik	12-2009	Added Junction box data
Rev D	M. Falik	12-2009	Additional content
Rev E	M. Falik	03-2010	Frequency ranges and latest support
Rev E1	M. Falik	05-2010	Added antenna connection
Rev E2 + 3	M. Falik	06-2010	Antenna connection table correction
Rev F, F1, F3 & F4	M. Falik	08-2010	Added 2x10-4, 0707 variants - PS cable lengths – MAX output
Rev G	M. Falik	11-2010	Product name change + additional content

### 11.2 Contact Information

#### Customer Service Help-Desk for customer service emergency

Airspan Networks have introduced the Airspan Tracker application to enable prompt and efficient Customer Support services.

If you do not have an Airspan Tracker account, please obtain login credentials by filling-in the form in the main page [www.airspan.com/Support](http://www.airspan.com/Support) Register New Account

#### Worldwide Headquarters:

Airspan Networks Inc.  
777, Yamato Road, Suite 310,  
Boca Raton, FL 33431, USA  
Tel: +1 561 893 8670

[www.airspan.com](http://www.airspan.com)

#### Feedback:

To provide feedback on this document, please send comments to the following email address: [documentfeedback@airspan.com](mailto:documentfeedback@airspan.com)