



AirHarmony-4000 Installation Guide

Integrated Duplexers

Part Number: UGD-D01080

System Release: 14.5

Revision: A

Published: January 2016

© Copyright by **Airspan Networks Inc.**, 2016. All rights reserved worldwide.

Legal Notices

The information contained within this document is proprietary and is subject to all relevant copyright, patent and other laws protecting intellectual property, as well as any specific agreements protecting Airspan Networks Inc. rights in the aforesaid information. Neither this document nor the information contained herein may be published, reproduced or disclosed to third parties, in whole or in part, without the express, prior, written permission of Airspan Networks Inc. In addition, any use of this document or the information contained herein for the purposes other than those for which it is disclosed is strictly forbidden.

Airspan Networks Inc. reserves the right, without prior notice or liability, to make changes in equipment design or specifications.

Information supplied by Airspan Networks Inc. is believed to be accurate and reliable. However, no responsibility is assumed by Airspan Networks Inc. for the use thereof nor for the rights of third parties which may be effected in any way by the use of thereof.

Any representation(s) in this document concerning performance of Airspan Networks Inc. product(s) are for informational purposes only and are not warranties of future performance, either expressed or implied. Airspan Networks Inc. standard limited warranty, stated in its sales contract or order confirmation form, is the only warranty offered by Airspan Networks Inc. in relation thereto.

This document may contain flaws, omissions or typesetting errors; no warranty is granted nor liability assumed in relation thereto unless specifically undertaken in Airspan Networks Inc. sales contract or order confirmation. Information contained herein is periodically updated and changes will be incorporated into subsequent editions. If you have encountered an error, please notify Airspan Networks Inc. All specifications are subject to change without prior notice.

Product performance figures quoted within this document are indicative and for information purposes only.

Acknowledgements



© Intel Corporation <http://www.intel.com/>



© Microsoft Corporation <http://www.microsoft.com>

Table of Contents

Document Information	1
Abstract	1
Revision History.....	1
Warnings and Cautions	2
Human Exposure to Radio Frequencies	2
Radio Interference	2
Modifications	2
General.....	2
Safety.....	3
Warning of Hazardous Voltages.....	3
Adherence to European Directive 1999/519/EC	3
Warning Symbols	4
Service Information.....	4
UL Information	4
Lightning Protection.....	4
DECLARATION OF CONFORMITY	5
GPS Compliance	6
Maximum Output TX Power	7
Power Consumption.....	7
Antenna System	7
Long Switched Beam Antenna	7
External Antenna.....	8
About This Document	8
Purpose	8
Intended Audience	9
Document Conventions.....	9
Document Organization	10
Related Reading	10

Customer Care Help Desk	11
Airspan Encourages Comments	11
1 Introduction	12
1.1 AirHarmony-4000	12
1.2 Deployment	12
2 Getting Started	14
2.1 Workflow of Installation	14
2.2 AirHarmony-4000 Installation Checklist	15
3 Verifying Prerequisites	15
3.1 Verifying Site Requirements	15
3.2 Verify Installation Requirements	15
3.2.1 Verify the Tools	15
3.2.2 Verify the Parts and Kits	16
3.2.3 Power Supply and Current	17
3.2.4 Panels	18
3.2.5 Physical Dimensions	19
3.2.6 Environmental	20
4 Installing AirHarmony-4000	21
4.1 Connecting the GPS Antenna	21
4.2 Pole/Wall Mount Assembly	21
4.2.1 Mounting on a Wooden Pole	22
4.2.2 Mounting on a Non-Wooden Pole	24
4.2.3 Mounting on a Wall	25
4.3 Securing AirHarmony-4000 to the Mounting Plate	27
5 AirHarmony-4000 Connections	31
5.1 Grounding	31
5.2 Remote Antenna Assembly	31
5.2.1 Connecting RF Jumper Cables to External Antenna	31
5.2.2 Weather-proofing the Antenna Connections	32

5.3	Cable Connections	32
5.3.1	Copper Ethernet Cable Assembly.....	32
	Hardware Requirements	32
	Assembly Instructions.....	32
5.4	Fiber Ethernet (SFP) Cable Installation	33
5.4.1	SFP Cable Connection.....	34
5.5	Connecting the AC Power Cable to AirHarmony-4000.....	35
5.5.1	Power Cable Preparation	36
A Job Sheet		39
B Abbreviations.....		40

Figures

Figure 1:	AirHarmony-4000 with Integrated Duplexers & cover	8
Figure 2:	AirHarmony-4000.....	13
Figure 3:	Workflow.....	14
Figure 4:	AirHarmony-4000 Unit, Bottom panel.....	18
Figure 5:	AirHarmony-4000 Unit, Top panel.....	19
Figure 18:	Attaching GPS antenna to unit.....	21
Figure 19:	Pole/Wall mounting plate	22
Figure 20:	Mounting plate on pole	23
Figure 21:	Through-bolt & Mounting plate.....	23
Figure 22:	Pole/Wall mounting plate (w/o bolt).....	24
Figure 23:	Mounting plate mounted.....	25
Figure 24:	Mounting Plate on Wall	26
Figure 25:	Lift unit and fit the slotted holes unto studs on top of mounting plate	27
Figure 26:	Align Pins	28
Figure 27:	AirHarmony mounted on Wooden Pole	28
Figure 28:	AirHarmony mounted on Concrete Pole	29
Figure 29:	AirHarmony being mounted on a Wall	30
Figure 30:	Grounding	31
Figure 31:	Gland connector - copper	32
Figure 32:	Ethernet Cable through connector	33
Figure 33:	LC duplex cable assembly	34
Figure 34:	Cable connector hook up to the board connector	34
Figure 35:	Slide on inner housing.....	35
Figure 36:	Slide over and click.....	35
Figure 37:	AC connector.....	36
Figure 38:	AC Connector disassembled	36
Figure 39:	Strip wire	36

Figure 40: power cable assembly.....	37
Figure 41: Connector on cable	37
Figure 42: Plug pins	37
Figure 43: Pin assignment	37
Figure 44: Attaching wires	38
Figure 45: Power cable attached to AirHarmony-4000	38

Tables

Table 1: AirHarmony--4000 B26 FCC Maximum Output TX Power.....	7
Table 2: AirHarmony-4000 B26 ETSI Maximum Output TX Power	7
Table 3: Power Consumption.....	7
Table 6: Typographic Conventions.....	9
Table 7. Minimum Hardware Requirements	15
Table 8. Parts & Kits	16
Table 9. Amperage Draw.....	18
Table 10: AirHarmony-4000 Physical Dimensions	19
Table 11: AirHarmony-4000 Environment Compliance	20
Table 12: Cable Hardware.....	32
Table 13: Job Sheet	39

Document Information

Abstract

This document details procedures for installing the Airspan’s AirHarmony-4000 INT, a Macro-class eNodeB variant and its place in the Airspan product suite. This document is intended for qualified personnel with a working knowledge of LTE.

Revision History

Revision Details	Date	Summary of Changes
Rev 0.1	January 2016	<ul style="list-style-type: none">Initial document - draft
		<ul style="list-style-type: none">
		<ul style="list-style-type: none">

Warnings and Cautions

Human Exposure to Radio Frequencies

The AirHarmony-4000 antennas should be operated from a minimum safe distance of 4.6m

Radio Interference

The AirHarmony generates, uses, and can radiate radio frequency energy and, if not installed and used in accordance with the instructions, may cause harmful interference to radio communications. However, there is no guarantee that interference will not occur in a particular installation. If this equipment does cause harmful interference to radio or television reception, which can be determined by turning the equipment on and off, the technician is encouraged to try to correct the interference by performing one or more of the following measures:

- Re-orientate or relocate the unit
- Increase separation between the units and/or End Devices
- Connect the equipment to an outlet on a circuit different from that to which the power source is connected

Modifications

Any changes and modifications to this device that are not expressly approved by Airspan Networks may void the user's authority to operate the equipment.

General

- Only qualified personnel should be allowed to install, replace, and service the equipment.
- The device cannot be sold retail, to the general public or by mail order. It must be sold to operators.
- Installation must be controlled.
- Installation must be performed by licensed professionals.
- Installation requires special training. The AirHarmony-4000 should be installed **ONLY** by experienced installation professionals who are familiar with local building and safety codes and, wherever applicable, are licensed by the appropriate government regulatory authorities. Failure to do so may void Airspan's product warranty and may expose the end user or the service provider to legal and financial liabilities. Airspan and its resellers or distributors are not liable for injury, damage or violation of regulations associated with the installation of outdoor units or antennas.
- The device is to be installed in a Restricted Access Location.

Safety

1. Read this guide and follow all operating and safety instructions.
2. Keep all product information for future reference.
3. Static sensitive components inside - do not remove the lid or base: No user serviceable parts inside.
4. Position the power cord to avoid possible damage.
5. Do not place this product on or near a direct heat source, and avoid placing objects on the terminal.
6. To avoid electrical shock do not install this device during adverse conditions such as rain or inclement weather.
7. Use only a damp cloth for cleaning. Do not use liquid or aerosol cleaners. Disconnect the power before cleaning.
8. The units should not be located too near power lines or other electrical power circuits, where it can come into contact with such power lines or circuits.
9. The radio transceiver must be properly grounded to protect against power surges and accumulated static electricity. It is the user's responsibility to install this device in accordance with the local electrical codes.
10. Installation of the AirHarmony-4000 must be contracted to a professional installer.
11. Disconnect Device. The socket outlet should be easily accessible in case you have to disconnect the device.
12. When installed in the final configuration, the product must comply with the applicable Safety Standards and regulatory requirements of the country in which it is installed. If necessary, consult with the appropriate regulatory agencies and inspection authorities to ensure compliance.

Warning of Hazardous Voltages

On AC installations, hazardous voltages exist. Use caution when verifying or working with AC power. Remove metal jewelry that could come into contact with AC power.

On DC sections, short-circuiting the low voltage, low impedance circuits can cause severe arcing that may result in burns or eye damage. Remove rings, watches etc. to avoid shorting DC circuits.

Note: Airspan products do not contain hazardous substances (as defined in UK Control of Substances Hazardous to Health Regulations 1989 and the Dangerous Substances Regulations 1990). At the end of any Airspan products life cycle, the customer should consult with Airspan to ensure that the product is disposed of in conformance with the relevant regulatory requirements.

Adherence to European Directive 1999/519/EC

European Council Recommendation 1999/519/EC details basic restrictions and reference levels on human exposure to electromagnetic fields as advised by the ICNIRP. Adherence to these recommended restrictions and reference levels should provide a high level of protection as regards the established health effects that may result from exposure to electromagnetic fields.

Warning Symbols

The following symbols may be encountered during installation or troubleshooting. These warning symbols mean danger. Bodily injury may result if you are not aware of the safety hazards involved in working with electrical equipment and radio transmitters. Familiarize yourself with standard safety practices before continuing.



Electro-Magnetic Radiation



High Voltage

Service Information

Refer all repairs to qualified service personnel. Do not modify any part of this device, as this will void the warranty.

Disconnect the power to this product and return it for service if the following conditions apply:

- a. The terminal does not function after following the operating instructions outlined in this manual.
- b. The product has been dropped or the housing is damaged.

Locate the serial number of the terminal and record this on your registration card for future reference. Also record the MAC address, located on the product sticker.

UL Information

- The equipment must be properly grounded according with NEC and other local safety code requirements.
- Reminder to all the BWA system installers: Attention to Section 820-40 of the NEC which provides guidelines for proper grounding and, in particular, specifies that the cable ground shall be connected to the grounding system of the building, as close to the point of cable entry as is practical.
- AirHarmony-4000 is designed to operate in environmental conditions complying with IP66 and relevant standards.

Lightning Protection

WARNING: The following notes are general recommendations for the system. The wireless equipment should be installed by a qualified professional installer and must follow local and national codes for electrical grounding and safety. Failure to meet safety requirements and/or use of non-standard practices and procedures could result in personal injury and damage to equipment. A direct lightning strike may cause serious damage even if these guidelines are followed.

All outdoor wireless equipment is susceptible to lightning damage from a direct hit or induced current from a near strike. Lightning protection and grounding practices in local and national electrical codes serve to minimize equipment damage, service outages, and serious injury. Reasons for lightning damage are summarized as:

- Poorly grounded tower/antenna sites that can conduct high lightning strike energy into equipment.

- Lack of properly installed lightning protection equipment that can cause equipment failures from lightning induced currents.

A lightning protection system provides a means by which the energy may enter earth without passing through and damaging parts of a structure. A lightning protection system does not prevent lightning from striking; it provides a means for controlling it and preventing damage by providing a low resistance path for the discharge of energy to travel safely to ground. Improperly grounded connections are also a source of noise that can cause sensitive equipment to malfunction.

A good tower grounding system disperses most of the surge energy from a tower strike away from the building and equipment.

To limit the equipment damage due to a lightning strike, the following practices are recommended for the wireless system:

- Provide direct grounding from the antenna mounting bracket, the radio and antenna and the lightning/surge protectors to the same ground point at the base of the tower or a ground bus on the building. Use the grounding screws on the antenna bracket and the radio and antenna for terminating the ground wires.

- The AC wall outlet ground must be connected to the same grounding system as the eNodeB.

DECLARATION OF CONFORMITY

European Community, Switzerland, Norway, Iceland, and Liechtenstein

Declaration of Conformity with Regard to the R&TTE Directive 1999/5/EC

English:

This equipment is in compliance with the essential requirements and other relevant provisions of Directive 1999/5/EC.

Deutsch:

Dieses Gerät entspricht den grundlegenden Anforderungen und den weiteren entsprechenden Vorgaben der Richtlinie 1999/5/EU.

Dansk:

Dette udstyr er i overensstemmelse med de væsentlige krav og andre relevante bestemmelser i Direktiv 1999/5/EF.

Español:

Este equipo cumple con los requisitos esenciales así como con otras disposiciones de la Directiva 1999/5/EC.

Greek:

ΜΕ ΤΗΝ ΠΑΡΟΥΣΑ Airspan ΔΗΛΩΝΕΙ ΟΤΙ Ο ΕΞΟΠΛΙΣΜΟΣ ΣΥΜΜΟΡΦΩΝΕΤΑΙ ΠΡΟΣ ΤΙΣ ΟΥΣΙΩΔΕΙΣ ΑΠΑΙΤΗΣΕΙΣ ΚΑΙ ΤΙΣ ΛΟΙΠΕΣ ΣΧΕΤΙΚΕΣ ΔΙΑΤΑΞΕΙΣ ΤΗΣ ΟΔΗΓΙΑΣ 1999/5/ΕΚ.

Français:

Cet appareil est conforme aux exigences essentielles et aux autres dispositions pertinentes de la Directive 1999/5/EC.

Íslenska:

Þessi búnaður samrýmist lögboðnum kröfum og öðrum ákvæðum tilskipunar 1999/5/ESB.

Italiano:

Questo apparato é conforme ai requisiti essenziali ed agli altri principi sanciti dalla Direttiva 1999/5/EC.

Nederlands:

Deze apparatuur voldoet aan de belangrijkste eisen en andere voorzieningen van richtlijn 1999/5/EC.

Norsk:

Dette utstyret er i samsvar med de grunnleggende krav og andre relevante bestemmelser i EU-directiv 1999/5/EC.

Português:

Este equipamento satisfaz os requisitos essenciais e outras provisões da Directiva 1999/5/EC.

Suomalainen:

Tämä laite täyttää direktiivin 1999/5/EY oleelliset vaatimukset ja on siinä asetettujen muidenkin ehtojen mukainen.

Svenska:

Denna utrustning är i överensstämmelse med de väsentliga kraven och andra relevanta bestämmelser i Direktiv 1999/5/EC.

Român:

Acest echipament este în conformitate cu cerințele esențiale și alte prevederi relevante ale Directivei 1999/5/CE.

The Declaration of Conformity related to this product can be obtained from PLM@Airspan.com.

GPS Compliance

The GPS is in compliance with the essential requirements and other relevant provisions of Directive 1999/5/EC."

The GPS complies with the following EMC Common Regulatory Testing standards:

- EN55022: Radiated and Conducted Emissions
- CISPR 22: Class B
- EN 50081-1: Generic Emissions Class B
- EN 50082-1: Generic Immunity Class B
- EN 61000-4-2: Electrostatic Discharge Immunity
- EN 61000-4-3: Radiated RF EM Field Immunity Test
- EN 61000-4-4: Electrical Fast Transient/Burst Test
- EN 61000-4-6: Conducted Immunity
- EN 61000-4-8: Magnetic Field Immunity

Note: A GPS is recommended for synchronizing between LTE sectors.

Note: An optional GPS Lightning/Surge protector is available from Airspan when installing the GPS antenna in a remote location for lightning prone deployments.

Maximum Output TX Power

Table 1: AirHarmony--4000 B26 FCC Maximum Output TX Power

Frequency Band	FCC TX		Antenna Gain
	EIRP		
851-869 MHz	46.16 dBm	57.54 dBm	13.5 dBi

Table 2: AirHarmony-4000 B26 ETSI Maximum Output TX Power

Frequency Band	ETSI TX		Antenna Gain
	EIRP		
851-869 MHz	46 dBm	TBD dBm	13.5 dBi

Caution: Do not set maximum output TX power to higher than local regulations.

Power Consumption

AirHarmony-4000 has a maximum nominal power consumption of 130W. AirHarmony-4000 power consumption is described in the following table:

Table 3: Power Consumption

Duplex	Tx Power at RF Port (dBm)	Nominal Power Consumption (W)
TDD- FC1	2 x 43	265
FDD	2 x 43	340

Antenna System

AirHarmony-4000 comes in a range of frequency variants that can be mounted with different antenna options and formats. A typical installation will have a cross-polar sector or dual slant antenna connected to the appropriate Integrated Duplexers of the AirHarmony-4000 variant unit. Various antennas are designed specifically for AirHarmony-4000 deployments; specifications are available from Airspan separately.

Long Switched Beam Antenna

Long Switched Beam antenna variant includes a steerable antenna mounted on the unit with the following specification. The antenna is a multi-element cross polarized (dual slant) design which can be used in directional or Omni modes of operation.

Scenario #1 - The long switched beam antenna is mounted directly on the unit and connected via its two RF ports and the control port. The GPS antenna is either mounted on the top of the unit (if conditions allow) or mounted separately with approved lightning protection.

Scenario #2 - The long switched beam antenna is mounted on the pole above the unit connected via its two RF ports and the control port.

External Antenna

The externally mounted antenna should be a dual slant or cross polarized fixed antenna which is connected via DIN connectors located on the Integrated Duplexers. The antenna should be mounted to its appropriate mounting facility.

Note: When utilized in conjunction with iRelay as backhaul maintain a vertical separation of at least 1 meter.

Figure 1: AirHarmony-4000 with Integrated Duplexers & cover



About This Document

Purpose

This guide provides the workflow and step-by-step procedures for installing the Airspan's AirHarmony-4000 Macro-class eNodeB variant. These procedures include:

- Verify prerequisites
- Mount GPS
- Install Mounting bracket
- Install the AirHarmony-4000
- Mount Antenna (either LSBA or external antenna)

- Mount iRelay (if applicable)
- Connect to External Antenna (if applicable)
- Connect and manage cables
- Field Replacement of Filter Set (when required)

Intended Audience

This guide is intended for persons who are responsible for installing the AirHarmony-4000.

These persons should have a working knowledge of the equipment.

AirHarmony can be tightly integrated with Airspan's iBridge and iRelay transport solutions. AirHarmony-4000 supports an integrated PoE interface which powers and connects either iBridge, iRelay, or a third party WiFi Access Point. This configuration creates a single piece installation that supports full end to end IPv6 plug and play deployment by just adding power. For more details please refer to the iBridge and iRelay product specifications.

Document Conventions

This document uses the following typographic conventions.

Table 4: Typographic Conventions

Convention	Element
<u>Blue</u> underlined text	Cross-reference links.
Bold text	Keyboard buttons and GUI elements.
Command	Command names or phrases.
Computer output	Text displayed by the computer.
Hyperlinks	Website and e-mail addresses.
Danger	Signifies a hazardous situation—if not avoided—will cause death or serious injury. Describes how to avoid it.
Warning	Signifies a hazardous situation—if not avoided—can cause death or serious personal injury. Describes how to avoid it.
Caution	Signifies a hazardous situation—if not avoided—can void the product warranty, and cause property damage. Describes how to avoid it.
Important	Provides necessary information to explain a task.
Note	Provides additional information.
Tip	Provides helpful hints.

Document Organization

Chapter	Contents
Introduction	Provides a comprehensive overview of AirHarmony-4000 and its installation.
Getting Started	Provides workflows for initial install and workflow.
Verifying Prerequisites	Lists the hardware, software, and client requirements for installation.
AirHarmony-4000 Installation	Describes how to install AirHarmony-4000.
GPS Installation	Describes how to install the GPS antenna.
Connect and Manage Cables	Describes how to connect the cables.
Job Sheet	Provides information that aids users in performing the installation.
Abbreviations	Lists the abbreviations used in this document and their expansions.

Related Reading

The following documents contain related information:

AirHarmony-4000 Hardware Product Specification

Airspan LTE Commissioning Manual

Customer Care Help Desk

Airspan's *Customer Care Help Desk* offers prompt and efficient customer support services.

Note: To avail Airspan's *Customer Care Help Desk* support, you must be a registered user and must have a valid support contract. To register, click [here](#) and fill the **Registration** form.

To create and update issue logs, send e-mails to [Customer Care Help Desk](#). Once you submit your issue, the system generates a new issue and sends an issue number for your reference. The system uses this issue number to categorize and store e-mails under the appropriate issue.

To help *Customer Care Help Desk* identify your issue, include the issue number and your *Customer Care Helpdesk* account details in all further communications.

Main Operations

Airspan Communications Ltd.
Capital Point
33 Bath Road
Slough, Berkshire
SL1 3UF, United Kingdom
Tel: +44-1895-467-100

Worldwide Headquarters

Airspan Networks Inc.
777, Yamato Road, Suite 105
Boca Raton, FL 3341-4408, USA
Tel: +1 561 893 8670

Airspan Encourages Comments

Airspan welcomes any feedback and suggestions that help to improve the quality of the documentation. Send your feedback to documentfeedback@airspan.com.

1 Introduction

This section provides a descriptive overview of the Airspan's AirHarmony-4000 with Integrated Duplexers a Macro-class eNodeB variant and its place in the Airspan product suite.

This document is intended for readers with LTE working knowledge.

All information in this document is for general information only, and is subject for change without notice.

1.1 AirHarmony-4000

AirHarmony-4000 is part of Airspan's carrier-class LTE Advanced small cell eNodeB family. AirHarmony-4000 is a Macro-class product that supports 3GPP's Long Term Evolution (LTE) eNodeB specifications, providing high-speed data, mobility, Voice over LTE, and broadcast/multicast services in order to meet the demands of the LTE Mobile Carriers.

AirHarmony-4000 is a compact, easy to install Macro-class eNodeB, allowing an operator to deploy LTE broadband services using existing infrastructure or Street Furniture (e.g. street lamps, power poles, building rooftop or sides etc...)

AirHarmony-4000 employs Software Defined Radio (SDR) technology, together with two transmit and receive paths for each sector and a GPS antenna and receiver – all in a highly integrated, physically small and light, All-Outdoor package, targeted to blend seamlessly into the urban environment. This compact outdoor product minimizes physical footprint, power consumption and operator OPEX.

AirHarmony-4000 is a 2T2R solution that enables a flexible deployment scenarios, but can achieve higher coverage and throughput by combing multiple eNodeBs enabling the support of 4T4R, 4T8R, and 8T8R.

AirHarmony-4000 implements 2 x 20W transmitters (2 x 43 dBm) and fully supports the standard LTE (Uu/S1/X2) interfaces.

All Airspan eNodeB products, including AirHarmony-4000, are interoperable with a rich portfolio of 3rd party end user devices, including many handsets, indoor UEs, outdoor UEs and USB dongles from several ODMs, using various chipsets. For an updated of interoperability list, please contact your nearest Airspan Sales Representative.

Additionally, AirHarmony can be tightly integrated with Airspan's iBridge and iRelay transport solutions. AirHarmony-4000 supports an integrated PoE interface which powers and connects either iBridge, iRelay, or a third party Wi-Fi Access Point. This configuration creates a single installation that fully supports end to end IPv6 plug and play deployment by just adding power. For more details please refer to the iBridge and iRelay product specifications.

Note: For management please refer to the Airspan LTE Commissioning Manual as well as Netspan.

1.2 Deployment

A highly flexible and scalable 4G Base Station, the AirHarmony-4000 is capable of supporting LTE profiles across multiple frequency bands.

Note: AirHarmony-4000 must be properly grounded according with NEC and other local safety code requirements.

Figure 2: AirHarmony-4000

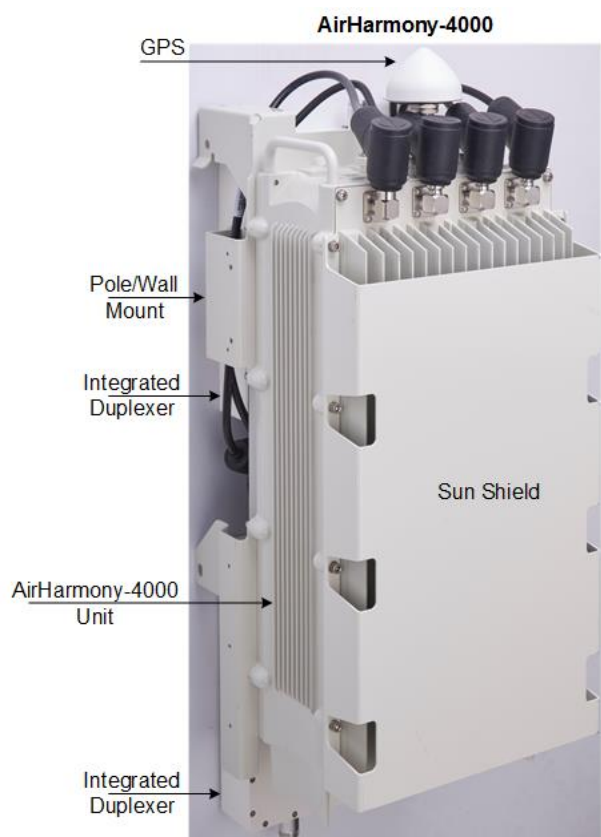

2 Getting Started

2.1 Workflow of Installation

The Workflow to install the AirHarmony-4000 is displayed in the following diagram:

Figure 3: Workflow

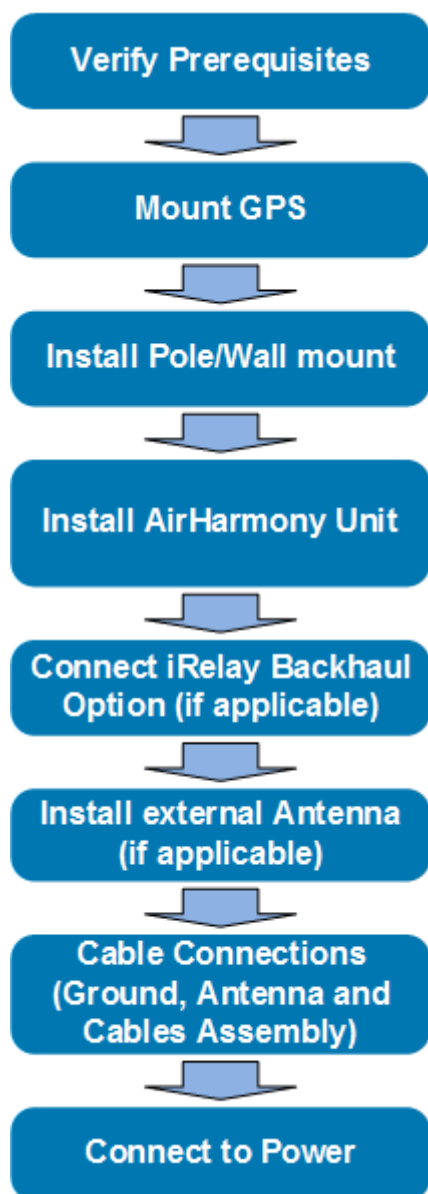

Caution: Antennas must be connected and attached before AirHarmony-4000 is powered on.

2.2 AirHarmony-4000 Installation Checklist

Plan the installation of the AirHarmony-4000 by using the Installation Checklist, which you can find as a removable job aid in [Appendix A](#) for this guide.

3 Verifying Prerequisites

Prior to installing the AirHarmony-4000, verify the required safety, power, tools, parts and components. This chapter includes the hardware, software, and client requirements for installation.

Important: Set up requirements for the installation is detailed in the **Job Sheet**, see [Appendix A](#).

3.1 Verifying Site Requirements

To set up the AirHarmony-4000, an IP connection to a Netspan server is required.

3.2 Verify Installation Requirements

3.2.1 Verify the Tools







Table 5. Minimum Hardware Requirements

Tool	Use
Medium Phillips head screw driver	for securing the M5 Pan Head screws on Filter set
#13 wrench	for securing the M8 Hex Head bolts on the Pole/wall mount
Small flat blade screw driver (insulated shaft recommended)	For AC power cable preparation
pliers	For AC power cable preparation
Knife	For AC cable preparation
Small side cutters	For AC power cable preparation
Wire strippers	For AC power cable preparation
1/2" Socket Wrench	For 5/16" Hex head (Lag) bolts when wall mounting

3.2.2 Verify the Parts and Kits

Note: Verify your order and requirements to ensure the correct unit type is being installed.

Table 6. Parts & Kits

Installation Kit / Part	Part No.	Airspan NO.	Consisting of:	Image
AirHarmony 4000 819 - 824 / 864 - 869 MHz (B26M), Connectorized	HAR40-CN-U26M1-B06AP	TBD	AirHarmony 4000 819 - 824 / 864 - 869 MHz (B26M), Connectorized w Ext. Duplexers, 2x Fiber + 2x Copper, PoE, AC	
AirHarmony 4000 universal wall & pole mounting kit	HAR40-U-PMK-1	903-03-257	<ul style="list-style-type: none"> • Pole/wall mount bracket • Screws for connecting the unit 	
GPS Antenna				
GPS Antenna	GPS-ANT-3	350-05-009	GPS Antenna with built-in high, interference rejection	
Or				
GPS Antenna Kit	GPS-HAR-KIT-1	N/A	AirHarmony GPS Kit (including antenna, bracket, 80cm cable and surge protection kit)	
LSBA Control Cable				
Long SBA control cable AISG to AISG 1.5m	CBL-SBAL-CTRL-1.5-1	680-00-191		
Long SBA control cable AISG to AISG 3m	CBL-SBAL-CTRL-3-1	680-00-192		
Long SBA control cable AISG to AISG 5m	CBL-SBAL-CTRL-5-1	680-00-193		
Long SBA control cable AISG to AISG 10m	CBL-SBAL-CTRL-10-1	680-00-194		
Long SBA control cable AISG to AISG 16m	CBL-SBAL-CTRL-16-1	680-00-195		
Full AXS SM Fiber Cable				
Full AXS SM Fiber Cable 5m, Outdoor LC/DPX to LC, IP67	FIB-FA-5-LC-SM-1	686-00-016		

AirHarmony-4000 (Integrated Duplexers) Installation Guide

Installation Kit / Part	Part No.	Airspan NO.	Consisting of:	Image
Full AXS SM Fiber Cable 7.5m, Outdoor LC/DPX to LC, IP67	FIB-FA-7.5-LC-SM-1	686-00-017		
Full AXS SM Fiber Cable 15m, Outdoor LC/DPX to LC, IP67	FIB-FA-15-LC-SM-1	686-00-015		
Full AXS SM Fiber Cable 30m, Outdoor LC/DPX to LC, IP67	FIB-FA-30-LC-SM-1	686-00-009		
Full AXS SM Fiber Cable 50m, Outdoor LC/DPX to LC, IP67	FIB-FA-50-LC-SM-1	686-00-010		
Full AXS SM Fiber Cable 75m, Outdoor LC/DPX to LC, IP67	FIB-FA-75-LC-SM-1	686-00-011		
Full AXS SM Fiber Cable 100m, Outdoor LC/DPX to LC, IP67	FIB-FA-100-LC-SM-1	686-00-012		
Full AXS SM Fiber Cable 150m, Outdoor LC/DPX to LC, IP67	FIB-FA-150-LC-SM-1	686-00-013		
Full AXS SM Fiber Cable 200m, Outdoor LC/DPX to LC, IP67	FIB-FA-200-LC-SM-1	686-00-014		

3.2.3 Power Supply and Current

AirHarmony-4000 supports direct connection to AC power source:

- Operational Voltage Range: 100VAC~240VAC, 47Hz~63Hz

Table 7. Amperage Draw

Duplex	Tx Power at RF Port (dBm)	Maximum Power Consumption (W)
TDD-FC1	2 x 43	340
FDD	2 x 43	340

3.2.4 Panels

The following figures display the AirHarmony-4000 bottom and top panels.

The following displays the AirHarmony-4000's bottom panel.

Figure 4: AirHarmony-4000 Unit, Bottom panel

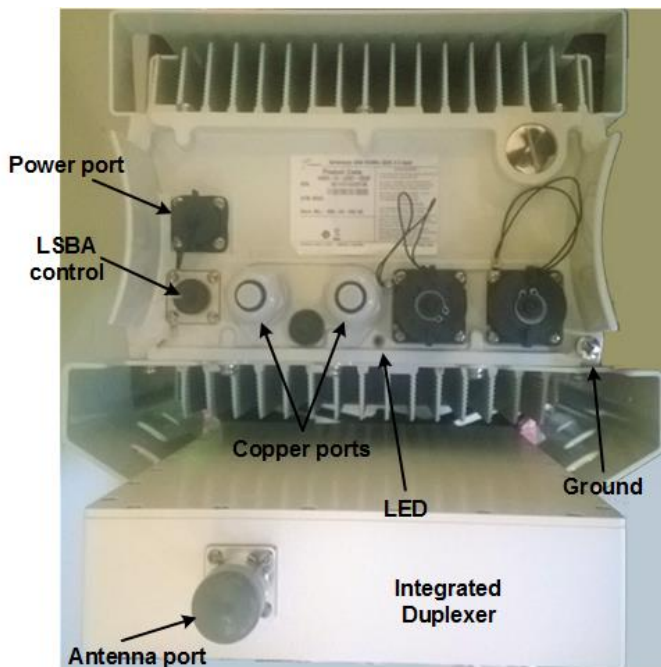

The following displays the AirHarmony-4000’s top panel.

Figure 5: AirHarmony-4000 Unit, Top panel

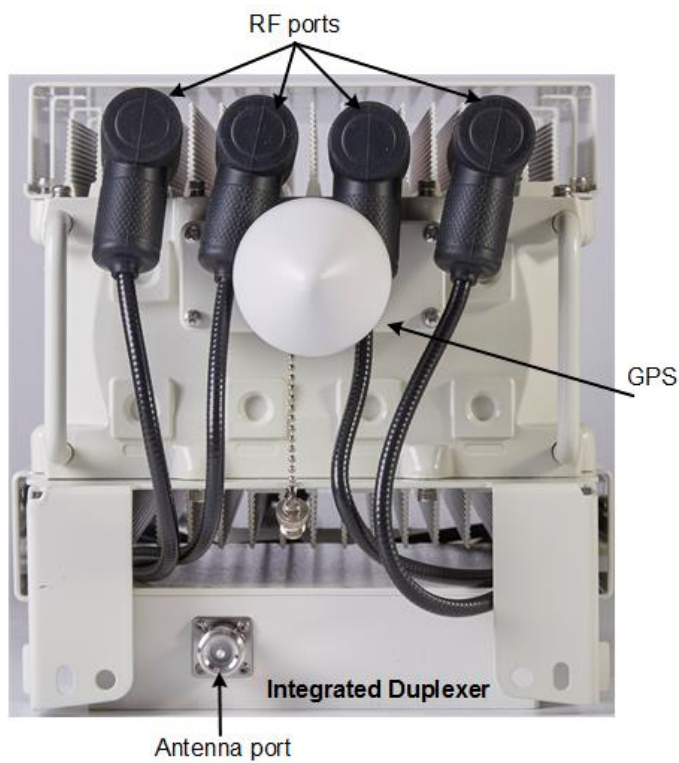

3.2.5 Physical Dimensions

AirHarmony-4000 is in an all outdoor enclosure.

Table 8: AirHarmony-4000 Physical Dimensions

Variant	Dimensions (H x W x D)	Comment
AirHarmony-4000	631 x 236 x 267 mm / 24.8 x 9.3 x 10.5 inch	

3.2.6 Environmental

AirHarmony-4000 meets the following environmental requirements:

- GR-63 Storage and Transportation
- ETSI EN 300-019-1-4 Operational (non-weather protected equipment)
- ETSI EN 300-019-1-1 Storage (weather protected, non-temperature controlled locations)
- ETSI EN 300-019-1-2 Transportation

Table 9: AirHarmony-4000 Environment Compliance

Type	Details	Standard Compliance
Operating temperature	-40°C to 55°C / -40°F to 131°F	ETSI 300 019 1-4
Operating humidity	5% - 100% non-condensing	ETSI 300 019 1-4
Storage temperature	-40°C to 70°C	N/A
Storage humidity	5% - 100% non-condensing	ETSI 300 019 1-4
Rain and dust ingress protection	IP66	N/A
Operational altitude	70-106 kPa as well as: From -60m to 1800m @ 40°C From 1800m to 4000m @ 30°C	ETSI 300 019 1-4
Solar radiation	1120 W/m ²	ETSI 300 019 1-4

4 Installing AirHarmony-4000

Install the AirHarmony-4000 eNodeB by pole/wall mount. AirHarmony-4000 is mounted on a pole or wall in close proximity to its external antenna (connectorized variant).

Remove the AirHarmony from its packaging in preparation for mounting.

Caution: Proper local rigging and hoisting practices should be followed when installing the AirHarmony-4000 on pole or wall.

4.1 Connecting the GPS Antenna

Prior to mounting the GPS antenna should be connected and it is recommended that the connection should be weather-proofed.

The following describes the connection of the GPS antenna which is installed directly to the top of the unit.

1. Unscrew the protective dust cap from the GPS antenna jack prior to mounting on the AirHarmony-4000.
2. Align the GPS jack with the plug attached to the top panel on the AirHarmony-4000.

Figure 6: Attaching GPS antenna to unit



Caution: Take care not to over tighten so as not to damage the threads.

Note: It is good practice to weather-proof all the antenna connections. This is done with a layer of self-amalgamating tape followed by an over layer of PVC tape. The weather-proofing the GPS connection is best done at this stage to give easier access to the connections.

4.2 Pole/Wall Mount Assembly

Install the AirHarmony-4000 eNodeB by pole/wall mount. AirHarmony-4000 is mounted on a pole or wall in close proximity to its external antenna (connectorized variant).

Caution: Proper local rigging and hoisting practices should be followed when installing the AirHarmony-4000.

4.2.1 Mounting on a Wooden Pole

The following images show the pole mount assembly on a wooden pole.

Caution: Take care to install the Pole/Wall mounting plate in the correct orientation. Verify that the mounting pins are facing upwards as shown below.

Figure 7: Pole/Wall mounting plate

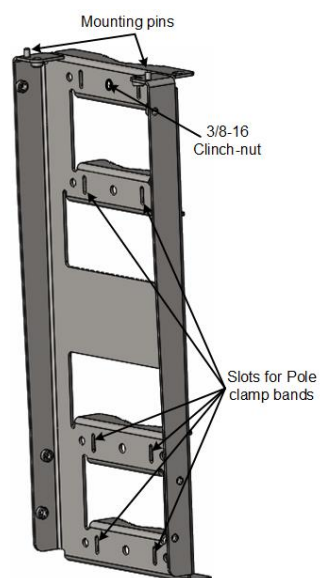

1. Select the location on the pole to mount the AirHarmony-4000. You can attach the AirHarmony-4000 to any pole from 1-7/8 to 16 inches (47.6 to 406.4 mm) in diameter.
2. Determine where to position the mounting plate on the pole and mark where to drill for insertion of the 3/8-16 through-bolt.

Note: Threaded rod and necessary hardware are **not** supplied by Airspan and are the responsibility of the installer.

3. Drill a minimum 7/16" hole to accept the 3/8-16 threaded rod.
4. Thread the 3/8-16 threaded rod into the provided clinch-nut attached on the Pole/Wall mounting plate.
5. Holding the mounting plate (with the attached threaded rod) pass the 3/8-16 threaded rod through the drilled hole in the pole.
6. Install on the exposed thread that protrudes from pole a flat washer, split washer, and then a 3/8"-16 hex nut and tighten.
7. Insert the clamp bands by passing them through the slots in the mounting plate, in three (3) places.

Note: The clamp bands are **not** supplied by Airspan and are the responsibility of the installer. Clamp bands should **not** be wider than 15.5 mm in order to fit in the slots on the mounting plate.

8. Tighten the clamp bands with large flat screwdriver.
-

Figure 8: Mounting plate on pole

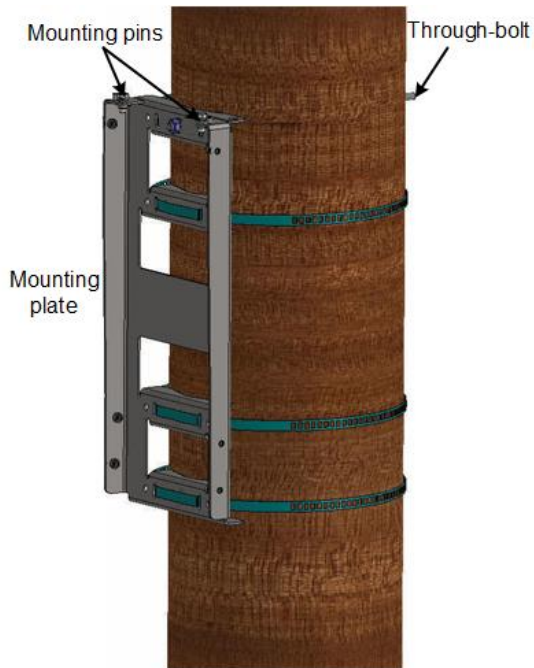
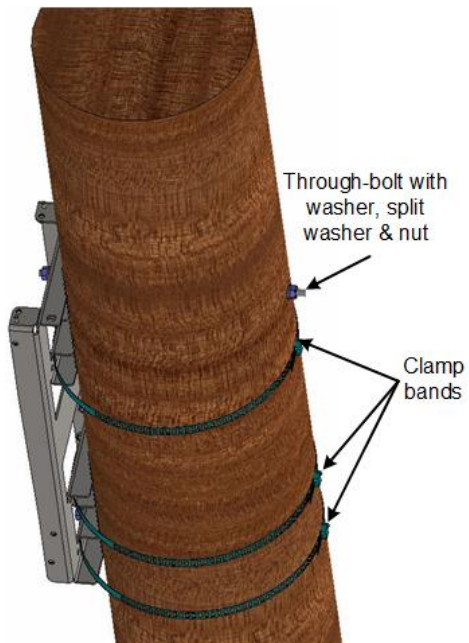

Figure 9: Through-bolt & Mounting plate



Mounting plate is installed and ready for AirHarmony-4000 mounting.

4.2.2 Mounting on a Non-Wooden Pole

The following images show the pole mount assembly on a non-wooden pole.

Caution: Take care to install the Pole/Wall mounting plate in the correct orientation. Verify that the mounting pins are facing upwards as shown below.

Figure 10: Pole/Wall mounting plate (w/o bolt)

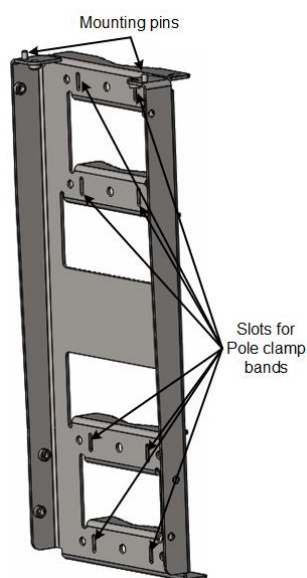

1. Select the location on the pole to mount the AirHarmony-4000. You can attach the AirHarmony-4000 to any pole from 1-7/8 to 16 inches (47.6 to 406.4 mm) in diameter.
2. Insert the clamp straps through the slots in the mounting plate passing them through the pole clamps.
3. Insert the clamp bands by passing them through the slots in the mounting plate, in four (4) places.

Note: The clamp bands are **not** supplied by Airspan and are the responsibility of the installer. Clamp bands should **not** be wider than 15.5 mm in order to fit in the slots on the mounting plate.

4. Tighten the clamp bands with large flat screwdriver.

Figure 11: Mounting plate mounted

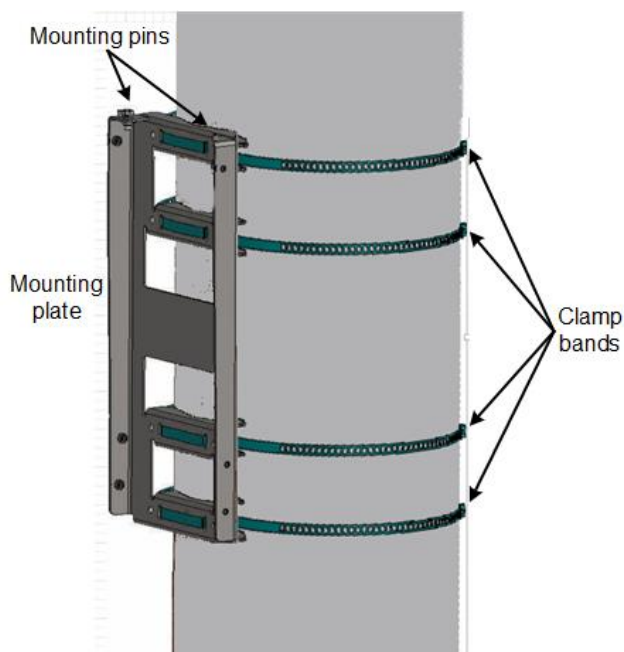

4.2.3 Mounting on a Wall

The following images show the wall mount assembly.

Caution: Take care to install the Pole/Wall mounting plate in the correct orientation. Verify that the mounting pins are facing upwards as shown below.

1. Position mounting plate against the wall with mounting pins facing up. Be sure to position the wall mounting plate straight with **level mounting** to ensure the unit sits evenly.
2. Mark the wall through the holes on the wall mount at the required height.
3. Attach the mounting plate to the wall using Lag bolts (x8 recommended).

Note: Lag bolts (x8) and necessary hardware are **not** supplied by Airspan and are the responsibility of the installer. Recommended minimum 5/16 x 4" dia. (8mm x 100mm) with appropriate plugs according to field conditions.

Figure 12: Mounting Plate on Wall

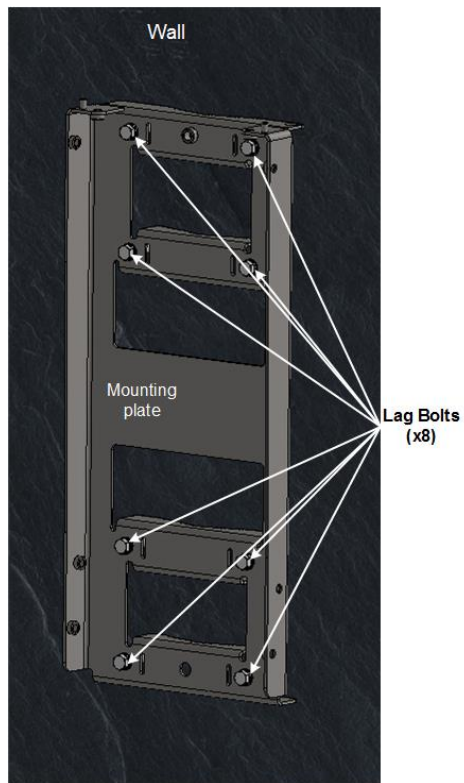

4.3 Securing AirHarmony-4000 to the Mounting Plate

Caution: Proper local rigging and hoisting practices should be followed when installing the AirHarmony-4000 on pole or wall.

To mount AirHarmony-4000 to the mounting plate, perform the following:

1. Lift up the AirHarmony-4000 unit and hook the slotted holes onto the mounting pins (studs) on the top of the mounting plate.

Figure 13: Lift unit and fit the slotted holes unto studs on top of mounting plate

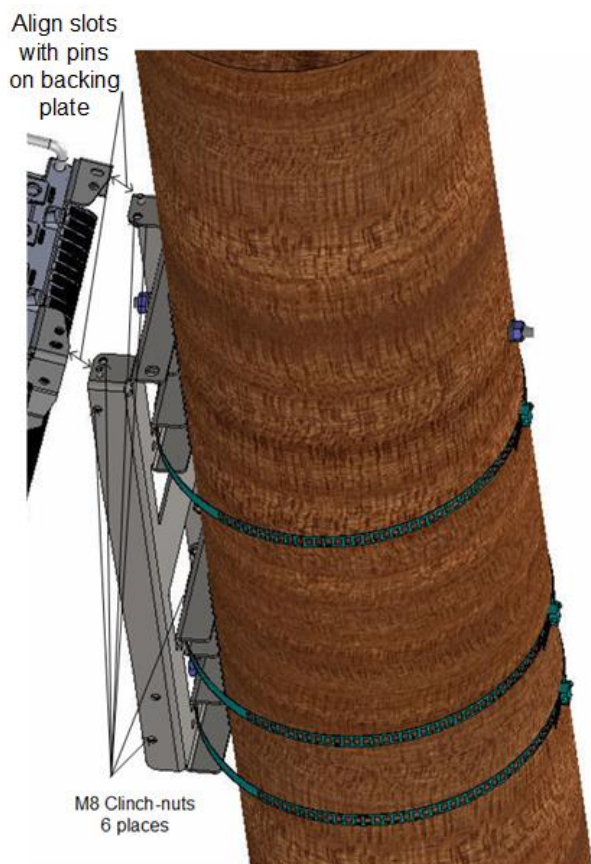

The following displays a close up of the Pin (stud) alignment.

Figure 14: Align Pins

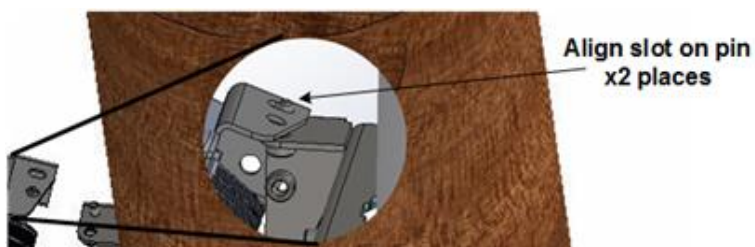

2. Lean the bottom of the unit into the mounting plate until the six (6) holes are aligned with the six (6) M8 clinch-nuts on the mounting plate. There are two (2) on the top, near the mounting pins and two (2) on either side of the mounting plate for a total of six (6) .
3. Once aligned insert the supplied M8x20 Hex head bolt with a split washer and a flat washer into each clinch-nut.
4. Check and tighten all six (6) M8x20 Hex head bolts.

The following displays the AirHarmony-4000 mounted on a wooden pole.

Figure 15: AirHarmony mounted on Wooden Pole



The following displays the AirHarmony-4000 mounted on a concrete pole.

Figure 16: AirHarmony mounted on Concrete Pole

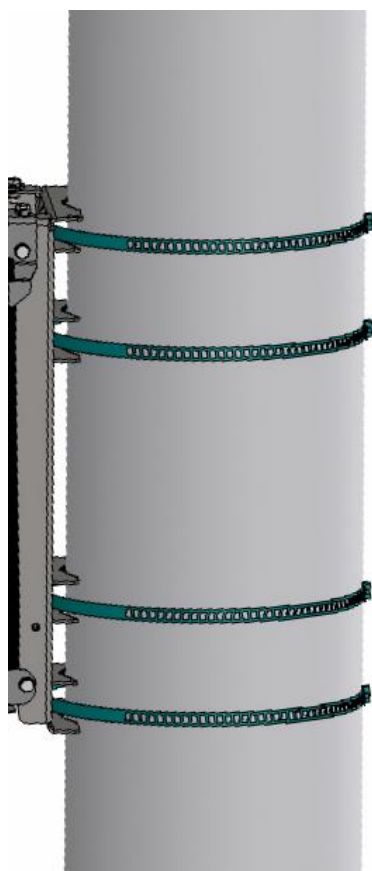

TBD

The following displays the AirHarmony-4000 being mounted on a wall.

Figure 17: AirHarmony being mounted on a Wall

TBD

5 AirHarmony-4000 Connections

This section describes Grounding procedure, cable preparation and connections and external antenna assembly.

5.1 Grounding

The AirHarmony-4000 requires a secure ground connection. The ground cable should be connected with a grounding screw fitted with a flat washer and lock washer to the bottom of the chassis clearly marked with the universal ground symbol as shown below.

Figure 18: Grounding

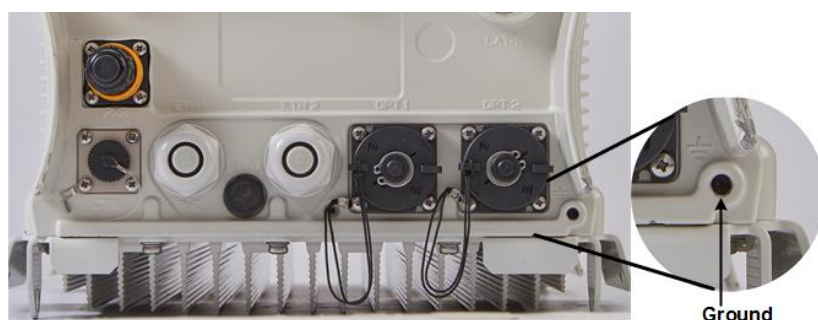

The cable should be grounded and bonded according to international or local standards.

5.2 Remote Antenna Assembly

The AirHarmony-4000 unit is be used with a remotely attached antenna.

For installation of a remotely mounted antenna follow the antenna manufacturer's instructions and connect the antenna to the AirHarmony-4000 external filter RF connectors using the appropriate cables. (N-type Heliax RF cables, ordered separately).

Caution: Take care not over tighten the RF connector. The connector nut should be tightened to a nominal torque of no more than 2.0 Nm (1.47 lb-ft). RF failures can result when the RF connector is over-tightened.

5.2.1 Connecting RF Jumper Cables to External Antenna

The following describes how to connect the antenna cables to the Integrated Duplexers.

1. Attach, connect and secure the RF cable between the external antenna and the appropriate RF connection on the top of the Integrated Duplexers.

Caution: Antennas must be connected and attached before AirHarmony is powered on.

Caution: Power down AirHarmony prior to disconnecting antenna.

2. Weather-proof the RF connections.

Note: The above is also applicable for **replacement** assembly.

5.2.2 Weather-proofing the Antenna Connections

Weather-proofing of all the connections is required. This is done with a layer of self-amalgamating tape followed by an over layer of PVC tape. The weather-proofing is best done at this stage to give easier access to the connections.

Note: Weather-proofing is best done at the assembly stage to give easier access to the connections. Weather-proofing is to be done to all RF connectors.

Verify the RF connectors are completely weather-proof.

5.3 Cable Connections

Note: The following images are for illustration purposes only. The actual tools or hardware may differ according to manufacturer.

5.3.1 Copper Ethernet Cable Assembly

The following demonstrates the recommended assembly instructions, hardware and tool requirements for the proper Ethernet cable assembly of the Ethernet Category 5e (enhanced) (CAT5e) cable used by Airspan products.

The Ethernet cable is connected using a standard RJ45 connector protected by a harsh environment protective casing.

Hardware Requirements

The following are the cable and connectors available from Airspan.

Table 10: Cable Hardware

Airspan Part Number	Description
CAT5e-STP-305M-R	CAT5e Ethernet Cable, 305M (1000ft), STP, Reel
RJ45-ETH-SHLD-CONN	RJ45 Ethernet Connector, Shielded

Assembly Instructions

The Copper Ethernet cable is connected to the AirHarmony-1000 using a Gland connector assembled on the bottom panel of the unit, as shown below.

Figure 19: Gland connector - copper

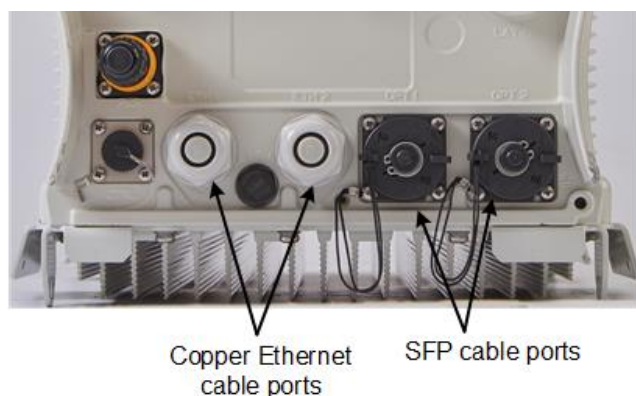

1. Remove the Gland connector by unscrewing the body from the AirHarmony-1000, using the (supplied) Gland wrench.
 2. Pass the prepared Ethernet cable through the tail nut, gland seal, body and front seal of the connector casing as shown below. Do not tighten the tail nut.
-

Figure 20: Ethernet Cable through connector

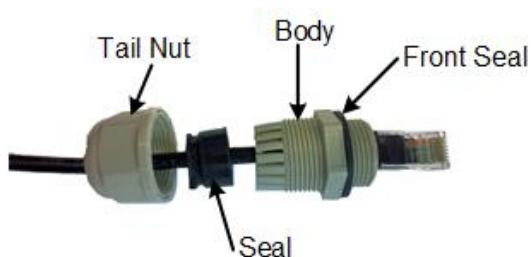

3. Seat the RJ45 connector plug securely into the body cavity of the AirHarmony-4000
 4. Tighten the Gland body into to the threaded hole on the bottom of the AirHarmony-4000.
 5. Tighten the tail nut on to the body using the included Gland wrench, forcing the seal compress around the cable.
 6. Once the connector is properly installed, the cable should be positioned and secured to minimize stress on the cable.
-

5.4 Fiber Ethernet (SFP) Cable Installation

The Fiber Ethernet Small form-factor pluggable transceiver (SFP) must be connected to the AirHarmony -4000 using an outdoor fiber cable. The optical connection enables a one-hand installation of the connector. This enables the users to easily remove and replace the SFP transceiver module which eliminates the need to open the unit and expose its contents to hazardous weather conditions.

Note: Airspan recommends using the Finisar - FTLF1318P3BTL 1000BASE-LX which has

been tested and approved by Airspan. Available from Airspan if required.

5.4.1 SFP Cable Connection

Figure 21: LC duplex cable assembly



1. Remove the protective dust cap from the connector housing assembled on the unit.
 2. Line up the SFP transceiver module with the port and slide it into the port.
 3. Connect the cable connector onto the board connector.
-

Figure 22: Cable connector hook up to the board connector



4. Verify that the locking latch on the cable connector is engaged on the board connector.
5. Slide the inner housing and ground shield (if present) over the cable and over the molding.

Figure 23: Slide on inner housing



Note: Check that there no space between the inner housing and mounting flange. Check and remove any debris that might interfere with the connection.

6. Slide the outer shell over the inner housing and turn the outer bayonet shell 1/4 turn clockwise, until it clicks into place.

Figure 24: Slide over and click



Note: The shell should be hand tightened only. Do NOT use tools to tighten the shell.

Once the connector is properly installed, the cable should be positioned and secured to minimize stress on the cable and connector.

5.5 Connecting the AC Power Cable to AirHarmony-4000

Danger: Hazardous voltage! Before working, ensure that the power is removed from the power connection cables. When the system is powered on, *do not touch the power terminals*.

5.5.1 Power Cable Preparation

Tip: It is good practice to label both ends of the cable to identify which AirHarmony-4000 unit it is connected to.

Tip: It is good practice to leave a spare loop of cable (approximately 0.5m). This will allow for easier wiring and will allow the cable to be re-terminated if necessary in the future.

The power cable is connected to the AirHarmony-4000 connector (marked PWR) on the bottom panel of the unit.

1. Prepare the connector by unscrewing the body, included in the AirHarmony-4000 package.

Figure 25: AC connector



Figure 26: AC Connector disassembled



2. Strip back and remove the outer sheath to expose the inner black, white and green insulated wires to a length of 3 cm (1.18 in). Then strip back 6 mm (0.24 in) of the inner core insulation.

Figure 27: Strip wire



3. Thread the 3 wire (stranded 16AWG) cable through the tail nut, gland seal, body and rubber gasket of the connector casing as shown below. Do not tighten the tail nut.

Figure 28: power cable assembly



4. Insert the stripped wire ends of the cable into the connector sleeves.

Figure 29: Connector on cable



5. Secure the wire ends of the power cable into the head part of the connector, as shown below.

Figure 30: Plug pins

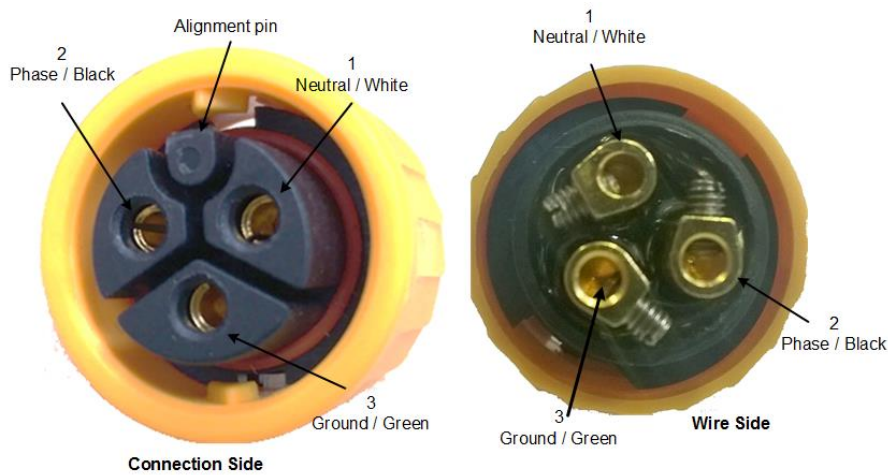

Figure 31: Pin assignment

Pin #	Wire Color	Description
1	White	Neutral
2	Black	Phase
3	Green	Ground

Figure 32: Attaching wires



6. Insert into connector, the by alignment pin determines the correct orientation.
7. Tighten the tail nut on to the body forcing the seal to compress around the power cable.

Caution: Do not over tighten the connector or the tail nut. The nut should be tightened to a torque of no more than 3.3 Nm (2.43 lb-ft) max.

Note: When securing the cable verify there is no tension on the connector so that it is easy to disconnect and re-connect for future maintenance actions.

Caution: The internal plastic parts of the mating connector are keyed. Take care to align these by visual inspection or by gently rotating the connector body until the key way sections align and the pins engaged fully before tightening.

Figure 33: Power cable attached to AirHarmony-4000



A Job Sheet

This job sheet enables the users to keep track of their installation. It covers all the prerequisites required for accomplishing the AirHarmony-4000 installation.

Table 11: Job Sheet

Site Requirements
Pole or wall for installation identified Position on pole or wall identified Pole access restrictions (highway regulations, other services on pole, power pole) Method of reaching pole positions (ladders, Elevated work platform) AC main fuse block available for AC/DC converter (where needed) Configuration programming details known Point of connection for Ethernet (if applicable) All equipment items available at the installation site: <ul style="list-style-type: none"> ● Main AirHarmony-4000 unit ● GPS Antenna ● Mounting bracket, through-bolt and pole clamps, or bolts if wall mount ● Copper Ethernet or SFP cable assembly ● Weather-proofing of the connections with a layer of self-amalgamating tape followed by an over layer of PVC tape.
Tool Requirements
(For further information, see Verify the Tools.) Large flat screw driver Small flat blade screw driver (insulated shaft recommended) Medium Philips head screw driver 13 mm wrench Knife pliers Small side cutters Wire strippers
Required Ancillary Equipment
Laptop PC for initial configuration Cable for temporary connection of the laptop
Other installed materials
Cable ties Labels (good to have)

B Abbreviations

Term	Expansion
3GPP	3rd Generation Partnership Project, responsible for LTE
ABS	Almost Blank Subframes
ACS	Adjacent Channel Selectivity is a measurement of a receiver's ability to process a desired signal while rejecting a strong signal in an adjacent frequency channel. ACS is defined as the ratio of the receiver filter attenuation on the assigned channel frequency to the receiver filter attenuation on the adjacent channel frequency.
AWGN	Additive White Gaussian Noise is a channel model in which the only impairment to communication is a linear addition of white noise with a constant spectral density and a Gaussian distribution of amplitude.
BER	Bit Error Rate
CN	Core Network
CP	Cyclic Prefix
CTC	Convolution Turbo Code is a high-performance forward error correction (FEC) code
dB	Decibel. A logarithmic unit used to describe a ratio (such as power ratio in radio telecommunications)
dBm	An abbreviation for the power ratio in decibels (dB) of the measured power referenced to one milliwatt (mW). It is used as a convenient measure of absolute power because of its capability to express both very large and very small values in a short form.
eNodeB	Evolved Node B, is the element in E-UTRAN of LTE .
ESP	Encapsulating Security Payloads (ESP) provide confidentiality, data-origin authentication, connectionless integrity, an anti-replay service (a form of partial sequence integrity), and limited traffic-flow confidentiality
E-UTRAN	Evolved UMTS Terrestrial Radio Access Network, is the air interface of 3GPP's Long Term Evolution.
EVM/RCE	The Error Vector Magnitude or EVM (sometimes also called Receive Constellation Error or RCE) is a measure used to quantify the performance of a digital radio transmitter or receiver. It is measured in dB or percentage (%) – the lower the better.
FDD	Frequency-Division Duplexing. A transceiver mode where the transmitter and receiver operate at different carrier frequencies.
GNSS	Global Navigation Satellite System is a term used to describe a satellite navigation system with global coverage. There are currently two fully operational GNSSs – the US GPS and the Russian GLONASS
GTP-U	GPRS Tunneling Protocol for User data is a relatively simple IP based tunneling protocol which permits many tunnels between each set of end points
HPBW	Half Power BandWidth is the angular separation in an antenna, in which the magnitude of the radiation pattern decreases by 50% (or -3 dB) from the peak of the main beam
ICS	In-channel selectivity is a measure of the receiver's ability to receive a wanted signal at its assigned Resource Block locations in the presence of an interfering signal
IPSec	Internet Protocol Security is a protocol suite for securing Internet Protocol (IP) communications by authenticating and encrypting each IP packet of a communication session
LED	Light Emitting Diode
LTE	Long Term Evolution
MAC	Medium Access Controller – responsible for several functions such Error Correction, Packet (De)Multiplexing, etc...
MBSFN	Multicast-Broadcast Single Frequency Network is an LTE feature designed to deliver services such as Mobile TV using the LTE infrastructure, and is expected to be a competitor to DVB-H-based TV broadcast

Term	Expansion
MCS	Modulation and Coding Scheme
MME	Mobility Management Entity is the key control-node for the LTE access-network. It is responsible, among other things for idle mode UE tracking and paging procedure including retransmissions
MTBF	Mean Time Between Failures
OFDMA	Orthogonal Frequency-Division Multiple Access (OFDMA) is a multi-user version of OFDM digital modulation scheme, used for eNodeB transmissions to UEs
PDCP	Packet Data Convergence Protocol. A Sub-Layer in LTE responsible for IP Header (De)Compression, etc...
PDU	Protocol Data Unit
PTP	Precision Time Protocol is used to synchronize clocks throughout a network. In this document, PTP is referring to IEEE1588-2008 protocol
RB	Resource Block
RLC	Radio Link Control. A Sub-Layer in LTE responsible for Ack/Nack, error correction, packet reordering, etc...
ROHS	Restriction Of Hazardous Substances
RRM	Radio Resource Management is used to cover all functions that are related to the assignment and sharing of radio resources among UEs
S-GW	Serving Gateway. A Core entity in the LTE EPC architecture responsible for routing and forwarding user data packets, while also acting as the mobility anchor for the user plane during inter-eNodeB handovers and as the anchor for mobility between LTE and other 3GPP technologies
SBA	Switched Beam Antenna
SC-FDMA	Single-Carrier FDMA is a frequency-division multiple access scheme, dealing with the assignment of multiple users to a shared communication resource. Used in LTE for UE transmissions to the eNodeB
SCTP	Stream Control Transmission Protocol is a reliable transport layer protocol , ensuring in-sequence transport of messages with congestion control like TCP
SDR	Software Defined Radio
TDD	Time-Division Duplexing. A transceiver mode where the transmitter and receiver operate on the same carrier frequency
UE	User Equipment. The end user in LTE
WEEE	Waste Electrical and Electronic Equipment