



# AIRSTRAND 2200 INSTALLATION GUIDE

## AirStrand 2200 Installation Guide

Document Part Number: DUG01287

Document Revision: A2

Published: October 2021

© Copyright by **Airspan Networks Ltd.**, 2021. All rights reserved worldwide.

### **Legal Notices**

The information contained within this document is proprietary, privileged and intended only for the recipient. As such, the information is subject to all relevant copyright, patent and other laws protecting intellectual property, as well as any specific agreements protecting Airspan Networks Ltd. rights in the aforesaid information. Neither this document nor the information contained herein may be published, reproduced, transmitted or disclosed to third parties, in whole or in part, without the express, prior, written permission of Airspan Networks Ltd. In addition, any use of this document or the information contained herein for the purposes other than those for which it is disclosed is strictly forbidden.

Airspan Networks Ltd. reserves the right, without prior notice or liability, to make changes in equipment design or specifications.

Information supplied by Airspan Networks Ltd. is believed in good faith to be accurate and reliable, while every care has been taken in preparing these documents. However, Airspan Networks Ltd. does not make any representations and gives no warranties of whatever nature in respect of these documents, including without limitation, the accuracy or completeness of any information, facts and/or opinions contained therein. No responsibility is assumed by Airspan Networks Ltd. for the use of the documents nor for the rights of third parties which may be effected in any way by the use thereof. The provision of these documents (and the documents themselves) does not constitute professional advice of any kind. Any representation(s) in these documents concerning performance of Airspan Networks Ltd. product(s) are for informational purposes only and are not warranties of future performance, either expressed or implied. Airspan Networks Ltd., its affiliates, directors, employees and agents shall not be held liable for any damages or losses, of any nature whatsoever, arising from any use of and/or reliance on the documents.

These documents may contain flaws, omissions or typesetting errors; no warranty is granted nor liability assumed in relation thereto unless specifically undertaken in Airspan Networks Ltd. sales contract or order confirmation. Information contained herein is periodically updated and changes will be incorporated into subsequent editions. If you have encountered an error, please notify Airspan Networks Ltd.

Product performance figures quoted within this document are indicative and for information purposes only.

# TABLE OF CONTENTS

Document Information.....	1
Revision History .....	1
Warnings and Cautions .....	2
Human Exposure to Radio Frequencies .....	2
Radio Interference.....	2
Modifications .....	2
General.....	2
⚠ Important Safety Instructions .....	2
Safety.....	3
Warning of Hazardous Voltages .....	3
Adherence to European Directive 2014/53/EU .....	3
Warning Symbols.....	4
Service Information .....	4
UL Information.....	4
Lightning Protection .....	4
DECLARATION OF CONFORMITY.....	6
GPS Compliance.....	8
Maximum Output TX Total Power .....	9
Power Consumption.....	9
Antenna Solution .....	9
About This Document.....	10
Purpose .....	10
Intended Audience .....	10
Document Conventions.....	10
Related Reading.....	11
1 Introduction.....	12
1.1 AirStrand 2200 .....	12
2 Getting Started .....	13
2.1 AirStrand 2200 Installation Checklist.....	13
3 Verifying Prerequisites .....	14
3.1 Verifying Site Requirements.....	14
3.2 Verify Installation Requirements.....	14
4 Installing AirStrand 2200 .....	18
4.1 Strand Mounting the AirStrand 2200 .....	18
4.2 Antenna Sectors.....	21
5 Connecting and Managing Cables.....	22
5.1 Removal of Connection Panel Cover.....	22
5.2 Grounding.....	23
5.3 Interface Connection .....	23
Appendix A. Job Sheet.....	25

Acronyms, Abbreviations, and Definitions ..... 26  
Customer Service Help Desk ..... 27  
Airspan Encourages Comments ..... 27

## FIGURES

Figure 1: AirStrand 2200.....	12
Figure 2: AirStrand 2200 Dimensions .....	16
Figure 3: Assemble Strand Hangers on Unit.....	19
Figure 4: Hanger and Clamp Assembly .....	19
Figure 5: AirStrand 2200 On Cable Strand .....	20
Figure 6: GPS Bracket Adjustment .....	20
Figure 7: AirStrand Sectors.....	21
Figure 8: Connection Panel Cover Removed .....	22
Figure 9: Ground Screw Connection.....	23
Figure 10: Use 2 Wrenches to Loosen .....	24

## TABLES

Table 1: AirStrand 2200 Maximum Output TX Total Power .....	9
Table 2: Antenna.....	9
Table 3: Typographic Conventions.....	10
Table 4. Minimum Hardware Requirements .....	14
Table 5. Parts & Kits .....	15
Table 6: AirStrand 2200 Physical Dimensions .....	16
Table 7: AirStrand 2200 Operational Tolerances .....	17
Table 8: System LED Function .....	24
Table 9: Job Sheet.....	25
Table 10: Acronyms, Abbreviations, and Definitions .....	26

## Document Information

This document details procedures for installing the Airspan's Air5G AirStrand 2200, as part of the 5G NR standard and its place in the Airspan product suite. This document is intended for qualified personnel with a working knowledge of 5G.

## Revision History

Revision	Date	Summary of Changes	Created by
Rev 0.1	July 2021	Initial document - draft	MSF
Rev 0.2 - 0.3	July 2021	Changes from comments	MSF
Rev 0.4 + 0.5	August 2021	Added - LED explanation, Antenna Sectors, comments	MSF
Rev A	August 2021	Published	MSF
Rev A1	August 2021	Minor terminology correction	CY
Rev A2	October 2021	Added Grounding requirement	CY / MSF

## Warnings and Cautions

### Human Exposure to Radio Frequencies

The AirStrand 2200 should be operated from a minimum safe distance of 49cm. (19.4 in.).

### Radio Interference

The AirStrand 2200 generates, uses, and can radiate radio frequency energy and, if not installed and used in accordance with the instructions, may cause harmful interference to radio communications. However, there is no guarantee that interference will not occur in a particular installation. If this equipment does cause harmful interference to radio or television reception, which can be determined by turning the equipment on and off, the technician is encouraged to try to correct the interference by performing one or more of the following measures:

- Re-orientate or relocate the unit
- Increase separation between the units and/or End Devices
- Connect the equipment to a circuit different from that to which the power source is connected

### Modifications

Any changes and modifications to this device that are not expressly approved by Airspan Networks may void the user's authority to operate the equipment.

### General

- Only qualified personnel should be allowed to install, replace, and service the equipment.
- The device cannot be sold retail, to the general public or by mail order. It must be sold to operators.
- Installation must be controlled.
- Installation must be performed by licensed professionals.
- Installation requires special training. The AirStrand 2200 should be installed ONLY by experienced installation professionals who are familiar with local building and safety codes and, wherever applicable, are licensed by the appropriate government regulatory authorities. Failure to do so may void Airspan's product warranty and may expose the end user or the service provider to legal and financial liabilities. Airspan and its resellers or distributors are not liable for injury, damage or violation of regulations associated with the installation of outdoor units or antennas.
- The device is to be installed in a Restricted Access Location.

### Important Safety Instructions

- Read and Save these instructions
- This Installation Guide contains instructions and warnings that should be followed during installation, and operation.
- Failure to follow these instructions could cause bodily injury and/or product failure

## Safety

1. Read this guide and follow all operating and safety instructions.
2. Supply cord is not shipped with the unit and is to be provided by user. Installation is to be performed by a qualified electrician according to local codes. Installation to be done in accordance with the National Electrical Code (NEC), ANSI/NFPA 70, the Canadian Electrical Code (CEC), Part I, CAN/CSA C22.1, and when applicable, the National Electrical Safety Code, IEEE C2.
3. Static sensitive components inside - do not remove the lid or base: No user serviceable parts inside.
4. The ground connection should be made before connecting to supply connections.
5. Position the power cord to avoid possible damage; do not overload circuits.
6. Do not place this product on or near a direct heat source, and avoid placing objects on the terminal.
7. To avoid electrical shock do not install this device during adverse conditions such as rain or inclement weather.
8. Use only a damp cloth for cleaning. Do not use liquid or aerosol cleaners. Disconnect the power before cleaning.
9. The units should not be located too near power lines or other electrical power circuits, where it can come into contact with such power lines or circuits.
10. The radio transceiver must be properly grounded to protect against power surges and accumulated static electricity. It is the user's responsibility to install this device in accordance with the local electrical codes.
11. Installation of the AirStrand 2200 46 must be contracted to a professional installer.
12. The circuit breaker should be easily accessible in case you have to disconnect the device.
13. When installed in the final configuration, the product must comply with the applicable Safety Standards and regulatory requirements of the country in which it is installed. If necessary, consult with the appropriate regulatory agencies and inspection authorities to ensure compliance.

## Warning of Hazardous Voltages

On AC installations, hazardous voltages exist. Use caution when verifying or working with AC power. Remove metal jewelry that could come into contact with AC power.

On DC sections, short-circuiting the low voltage, low impedance circuits can cause severe arcing that may result in burns or eye damage. Remove rings, watches etc. to avoid shorting DC circuits.



Airspan products do not contain hazardous substances (as defined in UK Control of Substances Hazardous to Health Regulations 1989 and the Dangerous Substances Regulations 1990). At the end of any Airspan products life cycle, the customer should consult with Airspan to ensure that the product is disposed of in conformance with the relevant regulatory requirements.

## Adherence to European Directive 2014/53/EU

European Council Recommendation 2014/53/EU details basic restrictions and reference levels on human exposure to electromagnetic fields as advised by the ICNIRP. Adherence to these recommended restrictions and reference levels should provide a high level of protection as regards the established health effects that may result from exposure to electromagnetic fields.



## Warning Symbols

The following symbols may be encountered during installation or troubleshooting. These warning symbols mean danger. Bodily injury may result if you are not aware of the safety hazards involved in working with electrical equipment and radio transmitters. Familiarize yourself with standard safety practices before continuing.



Caution, hot surface



Caution

Electro-Magnetic  
Radiation

High Voltage



DC

## Service Information

Refer all repairs to qualified service personnel. Do not modify any part of this device, as this will void the warranty.

Disconnect the power to this product and return it for service if the following conditions apply:

1. The terminal does not function after following the operating instructions outlined in this manual.
2. The product has been dropped or the housing is damaged.

Locate the serial number of the terminal and record this on your registration card for future reference. Also record the MAC address, located on the product sticker.

## UL Information

- The equipment must be properly grounded according with NEC and other local safety code requirements.
- Reminder to all the BWA system installers: Attention to Section 820-40 of the NEC which provides guidelines for proper grounding and, in particular, specifies that the cable ground shall be connected to the grounding system of the building, as close to the point of cable entry as is practical.
- AirStrand 2200 is designed to operate in environmental conditions complying with IP66 and relevant standards.

## Lightning Protection



**WARNING: The following notes are general recommendations for the system.**

The wireless equipment should be installed by a qualified professional installer and must follow local and national codes for electrical grounding and safety. Failure to meet safety requirements and/or use of non-standard practices and procedures could result in personal injury and damage to equipment. A direct lightning strike may cause serious damage even if these guidelines are followed.

All outdoor wireless equipment is susceptible to lightning damage from a direct hit or induced current from a near strike. Lightning protection and grounding practices in local and national electrical codes serve to minimize equipment damage, service outages, and serious injury. Reasons for lightning damage are summarized as:

- Poorly grounded tower/antenna sites that can conduct high lightning strike energy into equipment.
- Lack of properly installed lightning protection equipment that can cause equipment failures from lightning induced currents.

A lightning protection system provides a means by which the energy may enter earth without passing through and damaging parts of a structure. A lightning protection system does not prevent lightning from striking; it provides a means for controlling it and preventing damage by providing a low resistance path for the discharge of energy to travel safely to ground. Improperly grounded connections are also a source of noise that can cause sensitive equipment to malfunction.

A good tower grounding system disperses most of the surge energy from a tower strike away from the building and equipment.

To limit the equipment damage due to a lightning strike, the following practices are recommended for the wireless system:

- Provide direct grounding from the antenna mounting bracket, the radio and antenna and the lightning/surge protectors to the same ground point at the base of the tower or a ground bus on the building. Use the grounding screws on the antenna bracket and the radio and antenna for terminating the ground wires.
- The AC source ground must be connected to the same grounding system as the gNodeB.

## DECLARATION OF CONFORMITY

Declaration of Conformity with Regard to the R&TTE Directive 2014/53/EU

### Czech:

Airspan tímto prohlašuje, že tento přístroj je ve shodě se základními požadavky a dalšími příslušnými ustanoveními směrnice 2014/53 / EU.

### Danish:

Undertegnede, Airspan erklærer hermed, at følgende udstyrsenhed opfylder de væsentlige krav og andre relevante krav i direktiv 2014/53 / EF.

### Deutsch:

Hiermit erklärt Airspan, dass die Produkteinheit die grundlegenden Anforderungen und anderen relevanten Bestimmungen der Richtlinie 2014/53 / EU erfüllt.

### Estonian:

Käesolevaga kinnitab Airspan, et seadme seade vastab direktiivi 2014/53 / EL oluliste nõuetele ja muudele kõnealuse direktiivi asjakohastele sätetele.

### English:

This equipment is in compliance with the essential requirements and other relevant provisions of Directive 2014/53/EU.

### Español:

Por medio de este Airspan, declara que la unidad cumple con los requisitos esenciales y cualquier otra disposición aplicable o exigible de la Directiva 2014/53 / UE.

### Greek:

ΜΕ ΤΗΝ ΠΑΡΟΥΣΑ ΠΡΟΔΙΑΓΡΑΦΗ, η Airspan ΔΗΛΩΝΕΤΑΙ ότι η μονάδα συμμορφώνεται με τις ουσιώδεις απαιτήσεις και τις λοιπές σχετικές διατάξεις της οδηγίας 2014/53 / ΕΕ.

### Français:

Airspan déclare par la présente que l'appareil est conforme aux exigences essentielles et aux autres dispositions pertinentes de la directive 2014/53 / UE.

### Italiano:

Con la presente Airspan dichiara che questa unità è conforme ai requisiti essenziali e alle altre disposizioni pertinenti stabilite dalla direttiva 2014/53 / UE.

### Latvian:

Ar šo Airspan paziņo, ka vienība atbilst Direktīvas 2014/53 / ES būtiskajām prasībām un citiem attiecīgajiem noteikumiem;

### Lithuanian:

Šis „Airspan“ pareiškia, kad šis įrenginys atitinka esminius Direktyvos 2014/53 / ES reikalavimus ir kitas nuostatas.

### Nederlands:

Airspan verklaart hierbij dat de apparaateenheid voldoet aan de essentiële vereisten en andere relevante bepalingen van richtlijn 2014/53 / EU.

**Maltese:**

Hawnhekk, Airspan, tiddikjara li din l-unità tikkonforma mar-rekwiziti essenzjali u dispożizzjonijiet rilevanti oħra li jinsabu fid-Direttiva 2014/53 / UE.

**Hungarian:**

Alulírott, az Airspan kijelenti, hogy az egység megfelel a 2014/53 / EU irányelv vonatkozó alapvető követelményeinek és egyéb követelményeinek.

**Polish:**

Niniejszym Airspan oświadcza, że urządzenie jest zgodne z zasadniczymi wymaganiami i innymi odpowiednimi postanowieniami dyrektywy 2014/53 / UE.

**Português:**

Airspan declara que esta unidade está em conformidade com os requisitos essenciais e outras disposições da Diretiva 2014/53 / UE.

**Slovenian:**

Airspan izjavlja, da je ta enota skladna z bistvenimi zahtevami in drugimi ustreznimi določbami Direktive 2014/53 / EU.

**Slovak:**

Airspan týmto vyhlasuje, že tento prístroj spĺňa základné požiadavky a všetky príslušné ustanovenia Smernice 2014/53 / EÚ.

**Suomalainen:**

Airspan vakuuttaa täten, että laitteen tyyppi on direktiivin 2014/53 / EU olennaisten vaatimusten ja muiden asiaankuuluvien säännösten mukainen.

**Swedish:**

Därmed intygar Airspan att denna enhet överensstämmer med de väsentliga egenskapskraven och andra relevanta bestämmelser som anges i direktiv 2014/53 / EU.

**Íslenska:**

Airspan lýsir hér með yfir að þessi eining uppfylli grunnkröfur og aðrar kröfur tilskipunar 2014/53 / ESB.

**Norsk:**

Airspan erklærer herved at utstyrsenheten oppfyller grunnleggende krav og andre relevante krav i direktiv 2014/53 / EU.

**Român:**

Airspan declarăm pe propria răspundere că produsul produsului respectă cerințele esențiale și alte prevederi aplicabile din Directiva 2014/53 / UE.

The Declaration of Conformity related to this product can be obtained from [PLM@Airspan.com](mailto:PLM@Airspan.com).

## GPS Compliance

The GPS is in compliance with the essential requirements and other relevant provisions of Directive 2014/53/EU."

The GPS complies with the following EMC Common Regulatory Testing standards:

- EN55022: Radiated and Conducted Emissions
- CISPR 22: Class B
- EN 50081-1: Generic Emissions Class B
- EN 50082-1: Generic Immunity Class B
- EN 61000-4-2: Electrostatic Discharge Immunity
- EN 61000-4-3: Radiated RF EM Field Immunity Test
- EN 61000-4-4: Electrical Fast Transient/Burst Test
- EN 61000-4-6: Conducted Immunity
- EN 61000-4-8: Magnetic Field Immunity

## Maximum Output TX Total Power

Table 1: AirStrand 2200 Maximum Output TX Total Power

Product Code	Frequency Band	TX	Backhaul
AT22-N48-S	n48 (3550-3700MHz)	4x 1.25W (4x31dBm)	DOCSIS3.1



Do not set maximum output TX power to higher than local regulations.

## Power Consumption

AirStrand 2200 power consumption is <95W.

## Antenna Solution

The AirStrand 2200 antenna architecture is based on a dual sector with dual 2x2 SBA antennas. The two sectors support two carrier which can operate in same or in different frequencies. Each SBA antenna supports two possible configurations: 90° and 180° (refers to -6dB), enabling adapting antenna pattern to the specific deployment use case.

Table 2: Antenna

Per Sector	Single	Dual
Bandwidth / Gain	65° / 10.5dBi	150° / 8.5dBi
Max Total EIRP	44.5dBm	42.5dBm

## About This Document

### Purpose

This guide provides the workflow and step-by-step procedures for installing the Airspan's AirStrand 2200 variant. These procedures include:

- Verify prerequisites
- Assemble strand hangers on unit (if required)
- Install the AirStrand 2200 on the strand cable
- Connect and manage cables

### Intended Audience





This guide is intended for persons who are responsible for installing the AirStrand 2200.

These persons should have a working knowledge of the equipment.

### Document Conventions

This document uses the following typographic conventions.

Table 3: Typographic Conventions

Convention	Element
<a href="#">Blue</a> underlined text	Cross-reference links.
<b>Bold</b> text	Keyboard buttons and GUI elements.
Command	Command names or phrases.
Computer output	Text displayed by the computer.
<a href="#">Hyperlinks</a>	Website and e-mail addresses.
<b><u>Danger</u></b>	Signifies a hazardous situation—if not avoided—will cause death or serious injury. Describes how to avoid it.
 <b>Warning</b>	Signifies a hazardous situation—if not avoided—can cause death or serious personal injury. Describes how to avoid it.
 <b>Caution</b>	Signifies a hazardous situation—if not avoided—can void the product warranty, and cause property damage. Describes how to avoid it.
 <b>Information/Note</b>	Provides necessary information to explain a task.
 <b>Tip</b>	Provides helpful hints.

## Related Reading

The following documents contain related information:

- AirStrand 2200 Product Specification
- Airspan 5G Commissioning Manual (pending)



# 1 Introduction

This section provides a descriptive overview of the Airspan's AirStrand 2200 and its place in the Airspan product suite.

This document is intended for readers with LTE/5G working knowledge.

All information in this document is for general information only, and is subject for change without notice.

## 1.1 AirStrand 2200

AirStrand 2200 is part of Airspan's gNB product family which enable operators to provide 5G services.

The AirStrand 2200 supports two sectors of 5G NR and incorporates DOCSIS3.1 cable modem for backhaul. The unit receives power and backhaul by the HFC coaxial plant (60V/90V AC).

AirStrand 2200 is a compact, easy to install gNB, designed for deployment at street-level, leveraging its unique strand mount design. The product resembles a fiber splice box and doesn't expose any antenna.



For management please refer to the system Commissioning Manual.



AirStrand 2200 **must** be properly grounded (16AWG minimum) according with NEC and other local safety code requirements.

Figure 1: AirStrand 2200



## 2 Getting Started

### 2.1 AirStrand 2200 Installation Checklist

Plan the installation of the AirStrand 2200 by using the Installation Checklist, which you can find as a removable job aid in [Appendix A](#) for this guide.

## 3 Verifying Prerequisites

Prior to installing the AirStrand 2200, verify the required safety, power, tools, parts and components. This chapter includes the hardware, software, and client requirements for installation.



**Important:** Set up requirements for the installation is detailed in the Job Sheet, see [Appendix A](#).

### 3.1 Verifying Site Requirements

To set up the AirStrand 2200, an IP connection to a Network Management System (NMS) is required.

### 3.2 Verify Installation Requirements

#### 3.2.1 Verify the Tools

Table 4. Minimum Hardware Requirements

Tool	Use
9/16 inch wrench	for securing the hanger 3/8-16 bracket nuts
Philips screwdriver	For adjusting GPS and for securing the Ground wire (if required)

### 3.2.2 Verify the Parts and Kits



Verify your order and requirements to ensure the correct unit type is being installed.

Table 5. Parts & Kits

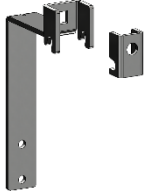
Installation Kit / Part	Part No.	Airspan No.	Consisting of:	Image
AirStrand 2200 unit + Mounting Kit	AT22-N48-S	TBD	<ul style="list-style-type: none"> <li>AirStrand 2200 5G Sub6 eNG n48 (3550-3700MHz)</li> <li>Hanger bracket x 2 with Clamps x 2 Hardware (bolts, threaded stud and nuts)</li> </ul>	
AirStrand 2200 Mounting Kit (for replacement if needed)	AT22-SMK-1	TBD	Hanger bracket x 2 with Clamps x 2 Hardware (bolts, threaded stud and nuts)	

### 3.2.3 Power Supply and Current

AirStrand 2200 supports a direct connection to AC Quasi-sine power source, to be fed from the HFC network.

Power Source requirements are:

- Operational Range: 44V-89VAC; 42V cutoff, 44V turn-on
- Safety approved (certified) according to IEC/EN/UL 60950-1

### 3.2.4 Physical Dimensions

AirStrand 2200 is in an all outdoor enclosure.

Table 6: AirStrand 2200 Physical Dimensions

Variant	Dimensions (L x W x H)
AT22-N48-S	500 x 180 x 203mm (19.7 x 7.0 x 8.0")
<b>Volume</b>	
17Liter	
<b>Weight</b>	
12 Kg / 26 Lbs.	

Figure 2: AirStrand 2200 Dimensions



### 3.2.5 Environmental



AirStrand 2200 is not meant to be used in a Marine environment.

AirStrand 2200 meets the following environmental requirements:

- GR-63 Storage and Transportation
- ETSI EN 300-019-1-4 Operational (non-weather protected equipment)
- ETSI EN 300-019-1-1 Storage (weather protected, non-temperature controlled locations)
- ETSI EN 300-019-1-2 Transportation

Table 7: AirStrand 2200 Operational Tolerances

Type	Details
Operating temperature	-40°C to +60°C* (-40°F to +140°F)
Operating humidity	5% - 95% with condensation
Public transportation temperature	-40°C to 70° C / -40°F to 158°F
Rain and dust ingress protection	IP67, IP65
Operational altitude	70-106KPA
Solar radiation	1120 W/m2

## 4 Installing AirStrand 2200

AirStrand 2200 is installed on the strand (the steel cable) that runs from pole to pole supporting other cables, such as telephone and cable company cables that run from pole to pole.

When mounting the AirStrand 2200 on a cable strand, you must use the Strand mount accessory kit. The kit contains several parts that you should assemble before mounting on a cable strand. The Strand Accessory kit contains the hanger bracket(s) and the hanger clamp(s) with the required hardware (included) required for installation.

To install AirStrand 2200 to a cable strand, you need to perform these operations:

- Attach the hanger brackets to the AirStrand 2200 unit.
- Lift and hang the AirStrand 2200 unit onto the strand cable.
- Fasten the hanger clamps to the hanger bracket(s) securing them to the strand cable.
- Connect interface (5/8" Interface connector type) to the cable infrastructure.

The GPS antenna comes already assembled on the AirStrand 2200 unit.

### 4.1 Strand Mounting the AirStrand 2200



The AirStrand 2200 is intended to be strand mounted in the telecommunications space between poles, not in the electrical space.

### 4.1.1 Hanger Bracket Assembly on the AirStrand 2200

The following is in the event that the Hanger bracket is not assembled.

1. Assemble both strand brackets to the sides of the unit. Inserting the 1/4-28 Hex screws (provided) into the threaded holes.

Figure 3: Assemble Strand Hangers on Unit

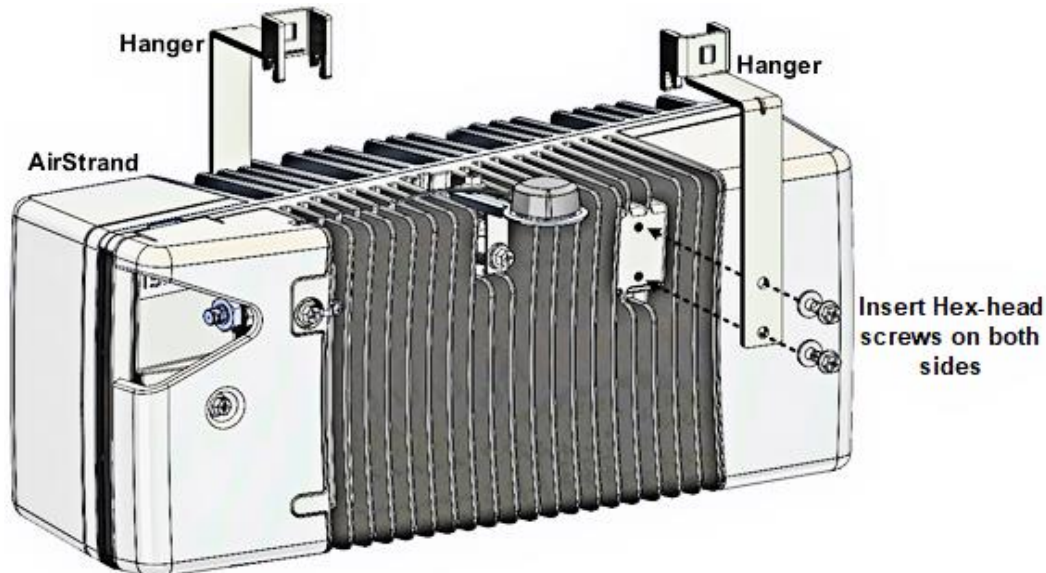

2. Orient the AirStrand 2200 unit to enable optimal positioning prior to placing on strand cable.
3. Lift and hang the AirStrand unit onto the cable strand, keep a hand on the unit for safety.

Figure 4: Hanger and Clamp Assembly

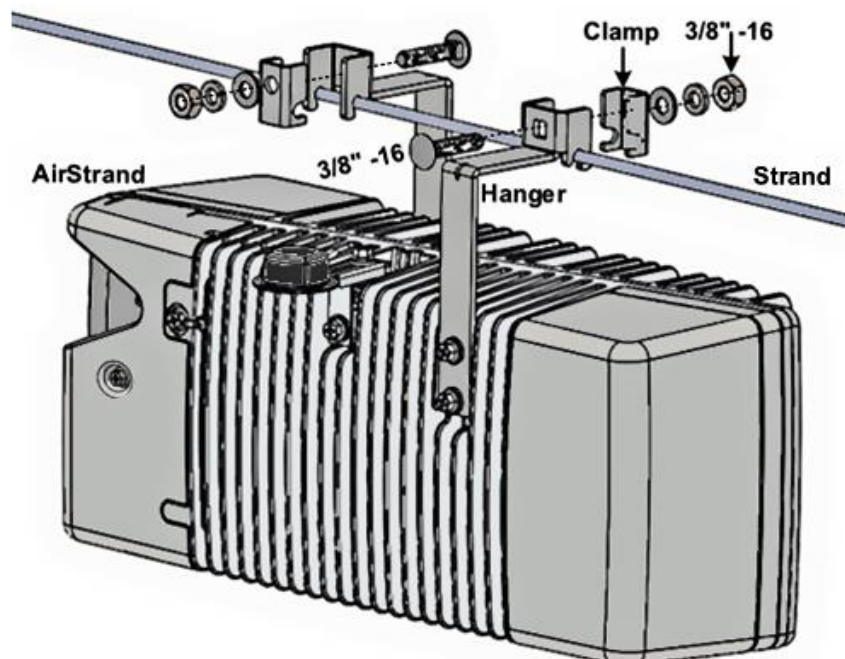

4. Assemble the hanger clamps onto the hangers, the cable diameter must be from 6 to 8mm (1/4 to 5/6 in.).



5. Insert the 3/8 – 16 bolts through the hanger and clamps, install the flat washer, split washer and nut on the bolt.
6. After assembly tighten the nuts.
7. The Hanger brackets are secured on the strand.

Figure 5: AirStrand 2200 On Cable Strand

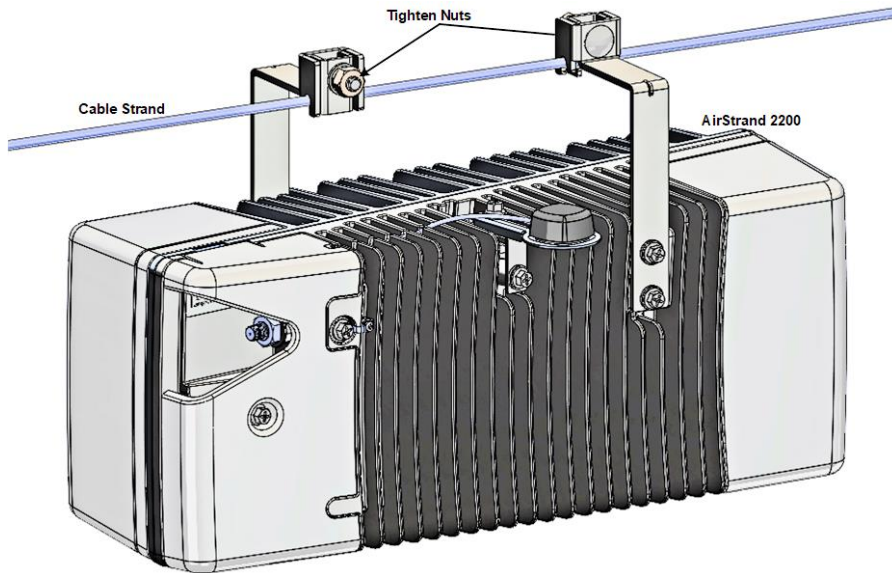

### 4.1.2 GPS Bracket Adjustment

After the AirStrand 2200 is securely fastened on the strand cable, the GPS and its bracket should be extended for maximum efficiency.

1. Loosen the 1/4-28 Hex screw on the GPS slide, which is on the top of the slide bracket.

Figure 6: GPS Bracket Adjustment

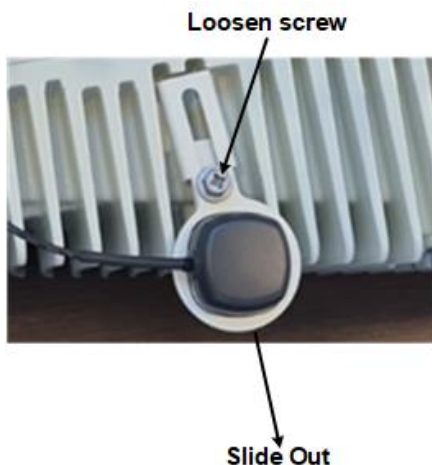

2. Extend the slide bracket.
3. Re-tighten the screw.

## 4.2 Antenna Sectors

The following displays the AirStrand 2200 antenna element sector direction.

Figure 7: AirStrand Sectors

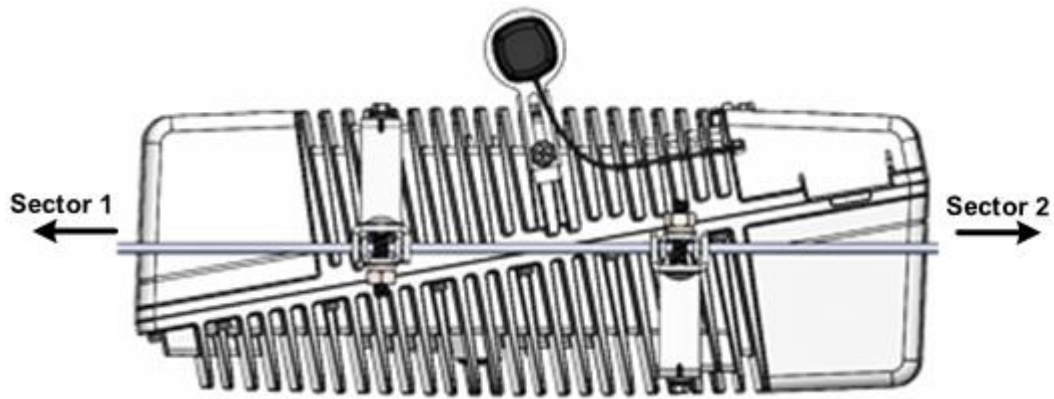

## 5 Connecting and Managing Cables

This section describes Grounding procedure, cable preparation and connections.

### 5.1 Removal of Connection Panel Cover

To access the connections, you must first remove connection panel cover.

1. Remove the screw that holds the access cover.
2. Gently squeeze the top and bottom and gently pull the cover off.
3. You now have access to the connections, shown below:

Figure 8: Connection Panel Cover Removed

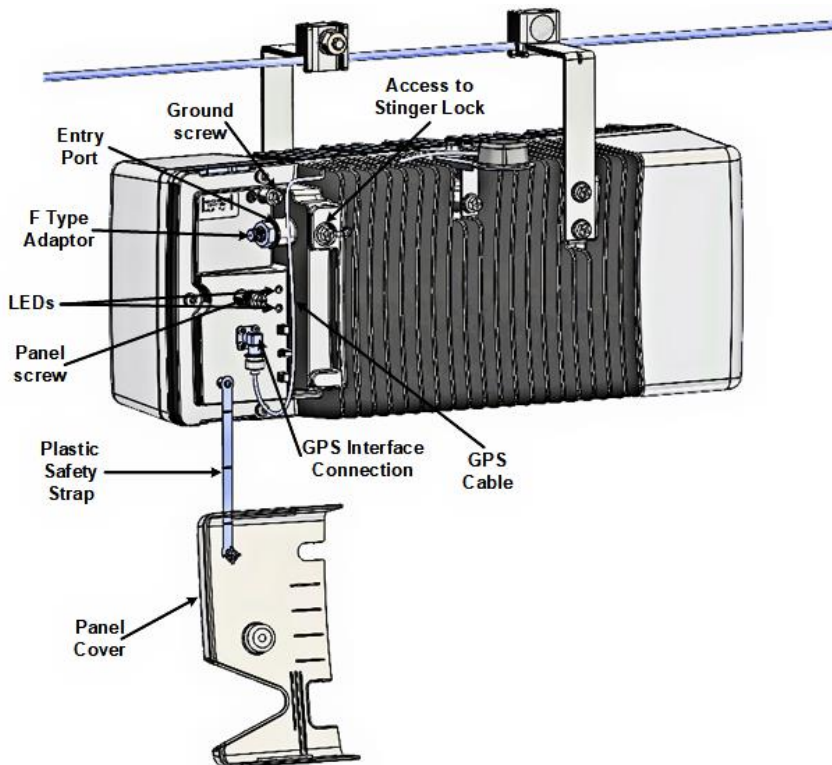

There is a plastic safety strap attached on the inside of the panel cover attached to the AirStrand unit to prevent the cover from falling.

## 5.2 Grounding

Once the AirStrand 2200 is securely attached on the strand it is required to connect an approved ground cable. The external ground cable should be connected with the grounding screw (1/4-16) fitted with a flat washer and lock washer (supplied) on the unit chassis clearly marked with the universal ground symbol. The grounding screw is pre-installed during assembly.



The external ground cable is not provided by Airspan. Cutting the Ground cable to the required length and crimping the grounding lug is performed by the Installer.

Figure 9: Ground Screw Connection

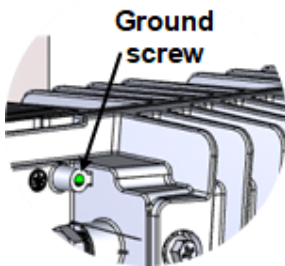

The cable should be grounded and bonded according to international or local standards.

## 5.3 Interface Connection



The shielded CATV cable supplies both power and data and is fed from an external isolated transformer.

Once the AirStrand 2200 is securely attached on the strand the installer should connect the shielded CATV cable terminated with an RF connector to the F-type connector (factory installed) connected to the unit's entry port.

1. Connect the shielded CATV cable terminated with an RF connector to the F-type connector connected (factory installed) to the unit's Entry port.



Supplied with F-type connector adapter but other connectors (i.e. stinger) are available if required.



When securing the cable make sure there is no tension on the connector so that it is easy to disconnect and re-connect for future maintenance actions.



Take care not to over tighten the F-type RF connector. The connector should be tightened to a nominal torque maximum of no more than 1.6NM/14.1600 in/lbs.

### 5.3.1 Connector Replacement

In the event the connector needs replacement use two (2) wrenches so as to prevent accidentally loosening the F-type connector adaptor connected to the unit's connecting outlet.

Figure 10: Use 2 Wrenches to Loosen



### 5.3.2 LED Display

Two LEDs are displayed on the inside of the panel of the unit, providing unit status indication - reporting system status: System / Access, Backhaul.

These are software controlled to provide a visual indication to the Installer and is illuminated once power is applied to the unit. It can be turned off during normal operation.

There are two (2) LEDs on the unit:

- Backhaul LED – indicates if the unit is connected to the network
- System LED – see table below

Table 8: System LED Function

State Name	LED Color	LED State	Description
Powering Up	White	On Continuously	Till running from operational SW image
Software loading / Startup	Green	Blinking (3Hz)	Till SW startup is finished and the product is ready to radiate
Normal operation	Blue	On Continuously	Normal operation (radiating). During normal operation the LED will <b>turn-off</b> after 10 min
Critical alarm	Red	On Continuously	Service affected
Major alarm	Orange	On Continuously	Service not affected

## Appendix A. Job Sheet

This job sheet enables the users to keep track of their installation. It covers all the prerequisites required for accomplishing the AirStrand 2200 installation.

Table 9: Job Sheet

Site Requirements
<ul style="list-style-type: none"> <li>• Cable strand for installation identified</li> <li>• Position on strand identified</li> <li>• Access restrictions (highway regulations, other services on pole, power pole)</li> <li>• Method of reaching strand positions (ladders, Elevated work platform)</li> <li>• Configuration programming details known</li> <li>• All equipment items available at the installation site:               <ul style="list-style-type: none"> <li>▪ Main AirStrand 2200 unit</li> <li>▪ GPS Antenna</li> <li>▪ Hangers, and required hardware</li> <li>▪ Required cables</li> <li>▪ Weather-proofing of the connections with a layer of self-amalgamating tape followed by an over layer of PVC tape.</li> </ul> </li> </ul>
Tool Requirements
(For further information, see <a href="#">Verify the Tools.</a> )
<ul style="list-style-type: none"> <li>• 9/16 inch wrench – securing Hanger clamps to Hanger</li> <li>• Philips screwdriver - securing the ¼-28 Hex-head screws</li> </ul>
Required Ancillary Equipment
<ul style="list-style-type: none"> <li>• Laptop PC for initial configuration</li> <li>• Cable for temporary connection of the laptop</li> </ul>
Other installed materials
<ul style="list-style-type: none"> <li>• Cable ties</li> <li>• Labels (good to have)</li> </ul>

## Acronyms, Abbreviations, and Definitions

Table 10: Acronyms, Abbreviations, and Definitions

Term	Expansion
dB	Decibel. A logarithmic unit used to describe a ratio (such as power ratio in radio telecommunications)
dBm	An abbreviation for the power ratio in decibels (dB) of the measured power referenced to one milliwatt (mW). It is used as a convenient measure of absolute power because of its capability to express both very large and very small values in a short form.
gNB	Next Generation Node B, is the element in 5G
GNSS	Global Navigation Satellite System is a term used to describe a satellite navigation system with global coverage. There are currently two fully operational GNSSs – the US GPS and the Russian GLONASS
LED	Light Emitting Diode
LTE	Long Term Evolution
MAC	Medium Access Controller – responsible for several functions such Error Correction, Packet (De)Multiplexing, etc...

## Customer Service Help Desk

Airspan's *Customer Care Help Desk* offers prompt and efficient customer support services.



To take advantage of Airspan's *Customer Care Help Desk* support, you must be a registered user and must have a valid support contract. To register, click [here](#) and fill the Registration form.

To create and update issue logs, send e-mails to [Customer Care Help Desk](#). Once you submit your issue, the system generates a new issue and sends an issue number for your reference. The system uses this issue number to categorize and store e-mails under the appropriate issue.

To help *Customer Care Help Desk* identify your issue, include the issue number and your *Customer Care Helpdesk* account details in all further communications.

### Main Operations

Airspan Communications Ltd.  
Capital Point  
33 Bath Road  
Slough, Berkshire  
SL1 3UF, United Kingdom  
Tel: +44-1895-467-100

### Worldwide Headquarters

Airspan Networks Inc.  
777, Yamato Road, Suite 310  
Boca Raton, FL 33431, USA  
Tel: +1-561-893-8670

## Airspan Encourages Comments

Airspan welcomes any feedback and suggestions that help to improve the quality of the documentation. Send your feedback to [documentfeedback@airspan.com](mailto:documentfeedback@airspan.com).

**Find more at [www.airspan.com](http://www.airspan.com).**